



# SAR TEST REPORT

No. I21Z60214-SEM01

For

**Shenzhen Tinno Mobile Technology Corp.**

**4G MIFI**

**Model Name: UM200AA**

with

**Hardware Version: V1.0**

**Software Version: UM200AA01.20.10**

**FCC ID: XD6UM200AA**

**Issued Date: 2021-3-25**

**Note:**

The test results in this test report relate only to the devices specified in this report. This report shall not be reproduced except in full without the written approval of CTTL.

The report must not be used by the client to claim product certification, approval, or endorsement by NVLAP, NIST, or any agency of the U.S. Government.

Test Laboratory:

CTTL, Telecommunication Technology Labs, CAICT

No. 52, Huayuan North Road, Haidian District, Beijing, P. R. China 100191.

Tel:+86(0)10-62304633-2512, Fax:+86(0)10-62304633-2504

Email: [ctl\\_terminals@caict.ac.cn](mailto:ctl_terminals@caict.ac.cn), website: [www.caict.ac.cn](http://www.caict.ac.cn)

©Copyright. All rights reserved by CTTL.

**REPORT HISTORY**

<b>Report Number</b>	<b>Revision</b>	<b>Issue Date</b>	<b>Description</b>
I21Z60214-SEM01	Rev.0	2021-2-27	Initial creation of test report
I21Z60214-SEM01	Rev.1	2021-3-22	Update ANNEX G Sensor Triggering Data Summary.
I21Z60214-SEM01	Rev.2	2021-3-25	Update ANNEX G Sensor Triggering Data Summary.

## TABLE OF CONTENT

<b>1 TEST LABORATORY .....</b>	<b>5</b>
1.1 TESTING LOCATION .....	5
1.2 TESTING ENVIRONMENT.....	5
1.3 PROJECT DATA .....	5
1.4 SIGNATURE.....	5
<b>2 STATEMENT OF COMPLIANCE .....</b>	<b>6</b>
<b>3 CLIENT INFORMATION .....</b>	<b>7</b>
3.1 APPLICANT INFORMATION.....	7
3.2 MANUFACTURER INFORMATION .....	7
<b>4 EQUIPMENT UNDER TEST (EUT) AND ANCILLARY EQUIPMENT (AE) .....</b>	<b>8</b>
4.1 ABOUT EUT.....	8
4.2 INTERNAL IDENTIFICATION OF EUT USED DURING THE TEST .....	9
4.3 INTERNAL IDENTIFICATION OF AE USED DURING THE TEST .....	9
<b>5 TEST METHODOLOGY .....</b>	<b>10</b>
5.1 APPLICABLE LIMIT REGULATIONS.....	10
5.2 APPLICABLE MEASUREMENT STANDARDS .....	10
<b>6 SPECIFIC ABSORPTION RATE (SAR).....</b>	<b>11</b>
6.1 INTRODUCTION.....	11
6.2 SAR DEFINITION.....	11
<b>7 TISSUE SIMULATING LIQUIDS .....</b>	<b>12</b>
7.1 TARGETS FOR TISSUE SIMULATING LIQUID.....	12
7.2 DIELECTRIC PERFORMANCE .....	12
<b>8 SYSTEM VERIFICATION .....</b>	<b>17</b>
8.1 SYSTEM SETUP.....	17
8.2 SYSTEM VERIFICATION.....	18
<b>9 MEASUREMENT PROCEDURES .....</b>	<b>19</b>
9.1 TESTS TO BE PERFORMED .....	19
9.2 GENERAL MEASUREMENT PROCEDURE.....	21
9.3 SAR MEASUREMENT FOR LTE.....	22
9.4 WI-FI MEASUREMENT PROCEDURES FOR SAR .....	24
9.5 POWER DRIFT.....	24
<b>10 AREA SCAN BASED 1-G SAR.....</b>	<b>25</b>
10.1 REQUIREMENT OF KDB.....	25
10.2 FAST SAR ALGORITHMS .....	25
<b>11 CONDUCTED OUTPUT POWER.....</b>	<b>26</b>

11.1 LTE MEASUREMENT RESULT .....	26
11.2 WI-FI MEASUREMENT RESULT .....	51
<b>12 SIMULTANEOUS TX SAR CONSIDERATIONS.....</b>	<b>54</b>
12.1 INTRODUCTION.....	54
12.2 TRANSMIT ANTENNA SEPARATION DISTANCES.....	54
12.3 SAR MEASUREMENT POSITIONS.....	55
12.4 STANDALONE SAR TEST EXCLUSION CONSIDERATIONS .....	55
<b>13 EVALUATION OF SIMULTANEOUS.....</b>	<b>56</b>
<b>14 SAR TEST RESULT .....</b>	<b>57</b>
14.1 SAR RESULTS FOR FAST SAR .....	57
14.2 SAR RESULTS FOR STANDARD PROCEDURE.....	62
14.3 WLAN EVALUATION FOR 2.4G .....	64
14.4 WLAN EVALUATION FOR 5G.....	66
<b>15 SAR MEASUREMENT VARIABILITY.....</b>	<b>71</b>
<b>16 MEASUREMENT UNCERTAINTY .....</b>	<b>72</b>
16.1 MEASUREMENT UNCERTAINTY FOR NORMAL SAR TESTS (300MHZ~3GHZ).....	72
16.2 MEASUREMENT UNCERTAINTY FOR NORMAL SAR TESTS (3~6GHZ) .....	73
16.3 MEASUREMENT UNCERTAINTY FOR FAST SAR TESTS (300MHZ~3GHZ).....	74
16.4 MEASUREMENT UNCERTAINTY FOR FAST SAR TESTS (3~6GHZ) .....	75
<b>17 MAIN TEST INSTRUMENTS.....</b>	<b>77</b>
<b>ANNEX A GRAPH RESULTS .....</b>	<b>78</b>
<b>ANNEX B SYSTEM VERIFICATION RESULTS .....</b>	<b>89</b>
<b>ANNEX C SAR MEASUREMENT SETUP .....</b>	<b>99</b>
<b>ANNEX D POSITION OF THE WIRELESS DEVICE IN RELATION TO THE PHANTOM .....</b>	<b>105</b>
<b>ANNEX E EQUIVALENT MEDIA RECIPES .....</b>	<b>107</b>
<b>ANNEX F SYSTEM VALIDATION .....</b>	<b>108</b>
<b>ANNEX G SENSOR TRIGGERING DATA SUMMARY .....</b>	<b>109</b>
<b>ANNEX H PROBE CALIBRATION CERTIFICATE .....</b>	<b>117</b>
<b>ANNEX I DIPOLE CALIBRATION CERTIFICATE.....</b>	<b>127</b>
<b>ANNEX J ACCREDITATION CERTIFICATE.....</b>	<b>198</b>

## 1 Test Laboratory

### 1.1 Testing Location

Company Name:	CTTL
Address:	No. 52, Huayuan North Road, Haidian District, Beijing, P. R. China 100191.

### 1.2 Testing Environment

Temperature:	18°C~25°C,
Relative humidity:	30%~ 70%
Ground system resistance:	< 0.5 $\Omega$
Ambient noise & Reflection:	< 0.012 W/kg

### 1.3 Project Data

Project Leader:	Qi Dianyuan
Test Engineer:	Lin Xiaojun
Testing Start Date:	February 13, 2021
Testing End Date:	February 21, 2021

### 1.4 Signature



---

Lin Xiaojun  
(Prepared this test report)



---

Qi Dianyuan  
(Reviewed this test report)

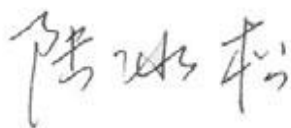

---

Lu Bingsong  
Deputy Director of the laboratory  
(Approved this test report)

## 2 Statement of Compliance

The maximum results of Specific Absorption Rate (SAR) found during testing for Shenzhen Tinno Mobile Technology Corp.4G MIFI UM200AA is as follows:

**Table 2.1: Highest Reported SAR (1g)**

Exposure Configuration	Technology Band	Highest Reported SAR 1g(W/kg)	Equipment Class
Body	LTE Band2	<b>0.91</b>	PCE
	LTE Band5	<b>0.97</b>	
	LTE Band12	<b>0.73</b>	
	LTE Band14	<b>0.72</b>	
	LTE Band30	<b>0.96</b>	
	LTE Band66	<b>0.75</b>	
	WLAN 2.4 GHz	<b>0.54</b>	DTS
	WLAN 5 GHz	<b>0.53</b>	NII

The SAR values found for the MIFI are below the maximum recommended levels of 1.6 W/kg as averaged over any 1g tissue according to the ANSI C95.1-1992.

The EUT battery must be fully charged and checked periodically during the test to ascertain uniform power output.

The measurement together with the test system set-up is described in annex C of this test report. A detailed description of the equipment under test can be found in chapter 4 of this test report. The highest reported SAR value is obtained at the case of **(Table 2.1)**, and the values are:

**0.97W/kg(1g).**

Remark:

This device supports both LTE B4 and LTE B66.Since the supported frequency span for LTE B4 falls completely within the supports frequency span for B66, both LTE bands have the same target power, and both LTE bands share the same transmission path; therefore, SAR was only assessed for LTE B66.

**Table 2.2: The sum of SAR values for Main antenna + WiFi-2.4G**

	Position	Main antenna	WiFi-2.4G	Sum
<b>Highest SAR value for Body</b>	Top 5mm (LTE Band2)	0.89	0.54	<b>1.43</b>

**Table 2.3: The sum of SAR values for Main antenna + WiFi-5G**

	Position	Main antenna	WiFi-5G	Sum
<b>Highest SAR value for Body</b>	Front 5mm (LTE Band30)	0.96	0.53	<b>1.49</b>

According to the above tables, the highest sum of reported SAR values is **1.49 W/kg (1g)**. The detail for simultaneous transmission consideration is described in chapter 13.

### 3 Client Information

#### 3.1 Applicant Information

Company Name:	Shenzhen Tinno Mobile Technology Corp.
Address/Post:	4/F, H-3 Building,OCT Eastern Industrial Park. NO.1 XiangShan East Road, Nan Shan District,Shenzhen, P.R.China
Contact Person:	xiaoping.li
Contact Email:	xiaoping.li@tinno.com
Telephone:	0755-86095550

#### 3.2 Manufacturer Information

Company Name:	Shenzhen Tinno Mobile Technology Corp.
Address/Post:	4/F, H-3 Building,OCT Eastern Industrial Park. NO.1 XiangShan East Road, Nan Shan District,Shenzhen, P.R.China
Contact Person:	xiaoping.li
Contact Email:	xiaoping.li@tinno.com
Telephone:	0755-86095550

## 4 Equipment Under Test (EUT) and Ancillary Equipment (AE)

### 4.1 About EUT

Description:	Shenzhen Tinno Mobile Technology Corp.
Model name:	UM200AA
Operating mode(s):	LTEBand2/4/5/12/14/30/66, Wi-Fi2.4G, Wi-Fi5G
Tested Tx Frequency:	1850 – 1910 MHz (LTE Band 2)
	824 – 849 MHz (LTE Band 5)
	699 – 716 MHz (LTE Band 12)
	788 –798 MHz (LTE Band 14)
	2305 –2315 MHz (LTE Band 30)
	1710 –1780 MHz (LTE Band 66)
	2412 – 2462 MHz (Wi-Fi 2.4G)
	5180 – 5240 MHz (Wi-Fi 5.2G)
	5260 – 5320 MHz (Wi-Fi 5.3G)
	5500 – 5720 MHz (Wi-Fi 5.5G)
5745 – 5825 MHz (Wi-Fi 5.8G)	
Test device Production information:	Production unit
Device type:	MiFi
Antenna type:	Integrated antenna
Hotspot mode:	Support



#### 4.2 Internal Identification of EUT used during the test

EUT ID*	IMEI	HW Version	SW Version
EUT1	865770050001876	V1.0	UM200AA01.20.10
EUT2	865770050001363	V1.0	UM200AA01.20.10
EUT3	865770050001595	V1.0	UM200AA01.20.10
EUT4	865770050002031	V1.0	UM200AA01.20.10
EUT5	865770050001967	V1.0	UM200AA01.20.10
EUT6	865770050002015	V1.0	UM200AA01.20.10

\*EUT ID: is used to identify the test sample in the lab internally.

**Note:** It is performed to do SAR with the EUT4~6 and conducted power with the EUT1~3.

#### 4.3 Internal Identification of AE used during the test

AE ID*	Description	Model	SN	Manufacturer
AE1	Battery	LT25H436270J	/	Ningbo Veken Battery Co., Ltd.

\*AE ID: is used to identify the test sample in the lab internally.

## 5 TEST METHODOLOGY

### 5.1 Applicable Limit Regulations

**ANSI C95.1–1992:**IEEE Standard for Safety Levels with Respect to Human Exposure to Radio Frequency Electromagnetic Fields, 3 kHz to 300 GHz.

It specifies the maximum exposure limit of **1.6 W/kg** as averaged over any 1 gram of tissue for portable devices being used within 20 cm of the user in the uncontrolled environment.

### 5.2 Applicable Measurement Standards

**IEEE 1528–2013:** Recommended Practice for Determining the Peak Spatial-Average Specific Absorption Rate (SAR) in the Human Head from Wireless Communications Devices: Measurement Techniques.

**KDB447498 D01: General RF Exposure Guidance v06:** Mobile and Portable Devices RF Exposure Procedures and Equipment Authorization Policies.

**KDB447498 D02:** SAR Procedures for Dongle Xmtr v02r01: SAR Measurement Procedures for USB Dongle Transmitters

**KDB648474 D04 Handset SAR v01r03:** SAR Evaluation Considerations for Wireless Handsets.

**KDB941225 D05 SAR for LTE Devices v02r05:** SAR Evaluation Considerations for LTE Devices

**KDB941225 D06 Hotspot Mode SAR v02r01:** SAR Evaluation Procedures for Portable Devices with Wireless Router Capabilities

**KDB248227 D01 802.11 Wi-Fi SAR v02r02:** SAR GUIDANCE FOR IEEE 802.11 (Wi-Fi) TRANSMITTERS

**KDB865664 D01 SAR measurement 100 MHz to 6 GHz v01r04:** SAR Measurement Requirements for 100 MHz to 6 GHz.

**KDB865664 D02 RF Exposure Reporting v01r02:** RF Exposure Compliance Reporting and Documentation Considerations

## 6 Specific Absorption Rate (SAR)

### 6.1 Introduction

SAR is related to the rate at which energy is absorbed per unit mass in an object exposed to a radio field. The SAR distribution in a biological body is complicated and is usually carried out by experimental techniques or numerical modeling. The standard recommends limits for two tiers of groups, occupational/controlled and general population/uncontrolled, based on a person's awareness and ability to exercise control over his or her exposure. In general, occupational/controlled exposure limits are higher than the limits for general population/uncontrolled.

### 6.2 SAR Definition

The SAR definition is the time derivative (rate) of the incremental energy ( $dW$ ) absorbed by (dissipated in) an incremental mass ( $dm$ ) contained in a volume element ( $dv$ ) of a given density ( $\rho$ ). The equation description is as below:

$$SAR = \frac{d}{dt} \left( \frac{dW}{dm} \right) = \frac{d}{dt} \left( \frac{dW}{\rho dv} \right)$$

SAR is expressed in units of Watts per kilogram (W/kg)

SAR measurement can be either related to the temperature elevation in tissue by

$$SAR = c \left( \frac{\delta T}{\delta t} \right)$$

Where:  $C$  is the specific heat capacity,  $\delta T$  is the temperature rise and  $\delta t$  is the exposure duration, or related to the electrical field in the tissue by

$$SAR = \frac{\sigma |E|^2}{\rho}$$

Where:  $\sigma$  is the conductivity of the tissue,  $\rho$  is the mass density of tissue and  $E$  is the RMS electrical field strength.

However for evaluating SAR of low power transmitter, electrical field measurement is typically applied.

## 7 Tissue Simulating Liquids

### 7.1 Targets for tissue simulating liquid

**Table 7.1: Targets for tissue simulating liquid**

Frequency(MHz)	Liquid Type	Conductivity( $\sigma$ )	$\pm 5\%$ Range	Permittivity( $\epsilon$ )	$\pm 5\%$ Range
750	Head	0.89	0.85~0.93	41.94	39.8~44.0
835	Head	0.90	0.86~0.95	41.5	39.4~43.6
1750	Head	1.37	1.30~1.44	40.08	38.1~42.1
1900	Head	1.40	1.33~1.47	40.0	38.0~42.0
2300	Head	1.67	1.59~1.75	39.47	37.50~41.44
2450	Head	1.67	1.59~1.75	39.47	37.5~41.4
5250	Head	4.66	4.43~4.89	35.99	34.19~37.79
5600	Head	5.07	4.82~5.32	35.53	33.75~37.31
5750	Head	5.27	5.01~5.53	35.3	33.5~37.1

### 7.2 Dielectric Performance

**Table 7.2: Dielectric Performance of Tissue Simulating Liquid**

Measurement Date yyyy/mm/dd	Frequency	Type	Permittivity $\epsilon$	Drift (%)	Conductivity $\sigma$ (S/m)	Drift (%)
2021/2/13	750 MHz	Head	42.5	1.34	0.89	0.00
2021/2/14	835 MHz	Head	40.69	-1.95	0.888	-1.33
2021/2/15	1750 MHz	Head	40.2	0.30	1.354	-1.17
2021/2/16	1900 MHz	Head	39.38	-1.55	1.411	0.79
2021/2/17	2300 MHz	Head	40.14	1.62	1.687	1.02
2021/2/18	2450 MHz	Head	39.2	0.00	1.796	-0.22
2021/2/19	5250 MHz	Head	36.07	0.39	4.729	0.40
2021/2/20	5600 MHz	Head	35.75	0.62	5.153	1.64
2021/2/21	5750 MHz	Head	35.73	1.05	5.201	-0.36

Note: The liquid temperature is 22.0°C

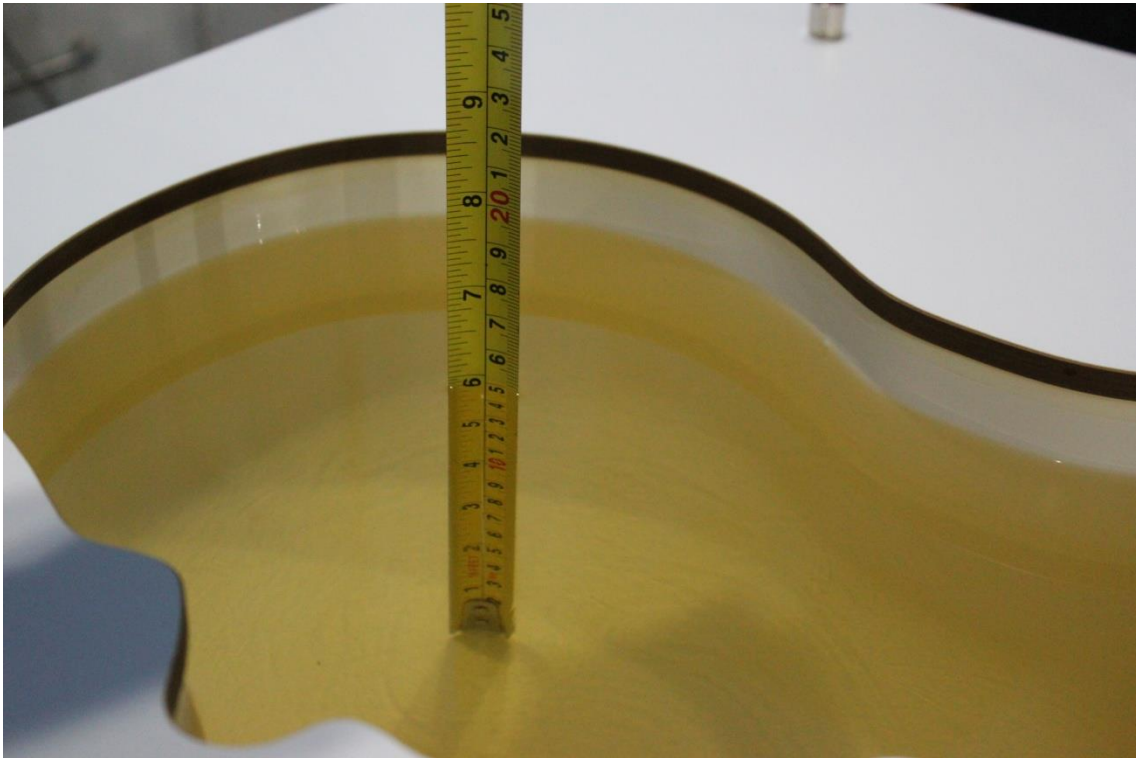

Picture 7-1 Liquid depth in the Head Phantom (750MHz)

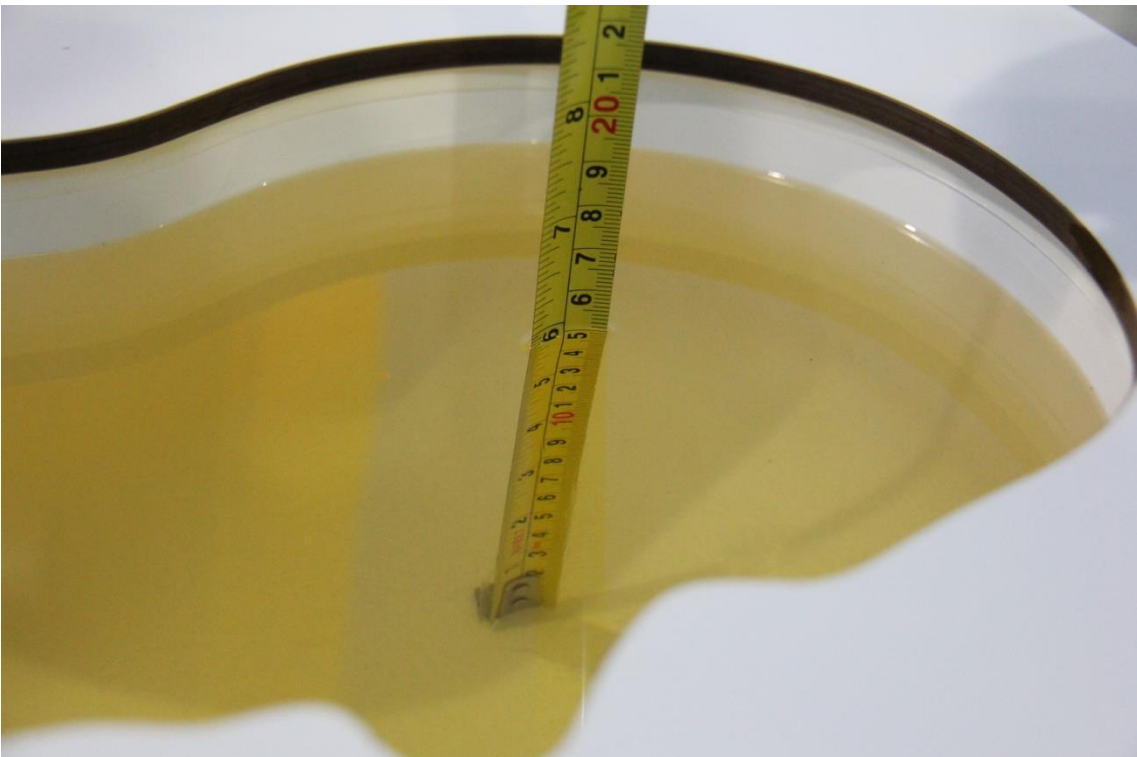

Picture 7-2 Liquid depth in the Head Phantom (835 MHz)



Picture 7-3 Liquid depth in the Head Phantom (1750 MHz)



Picture 7-4 Liquid depth in the Head Phantom (1900 MHz)

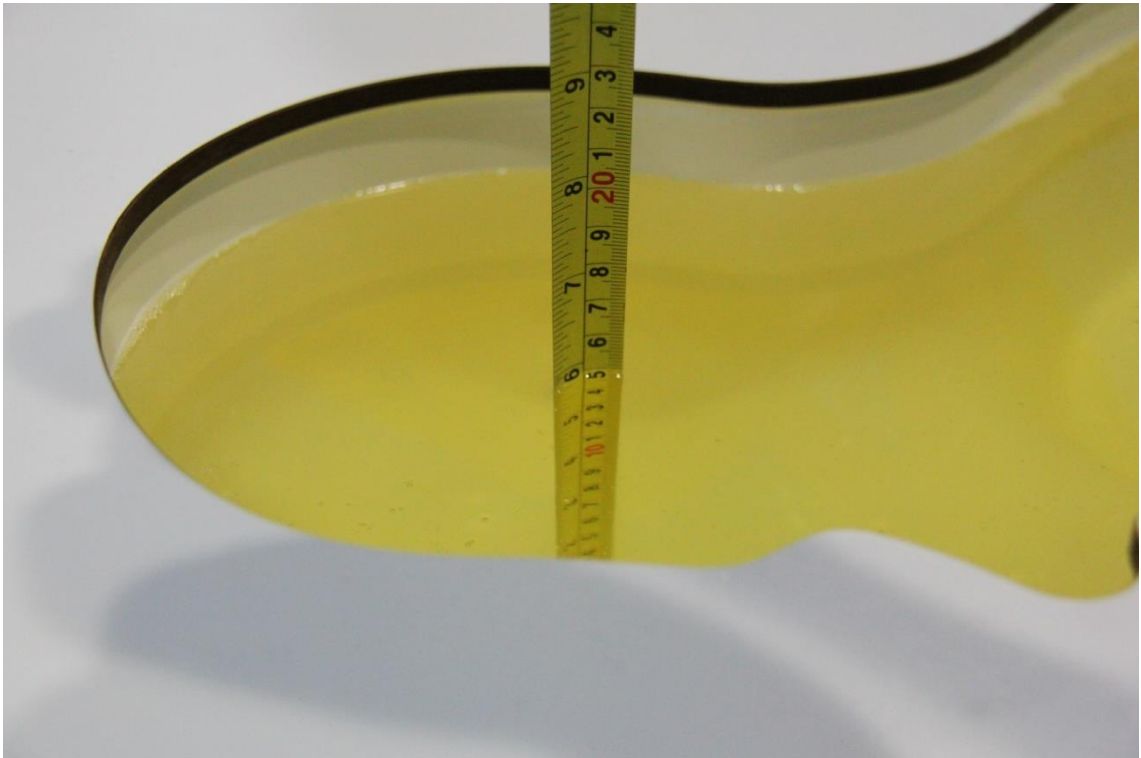

**Picture 7-5 Liquid depth in the Head Phantom (2450MHz)**

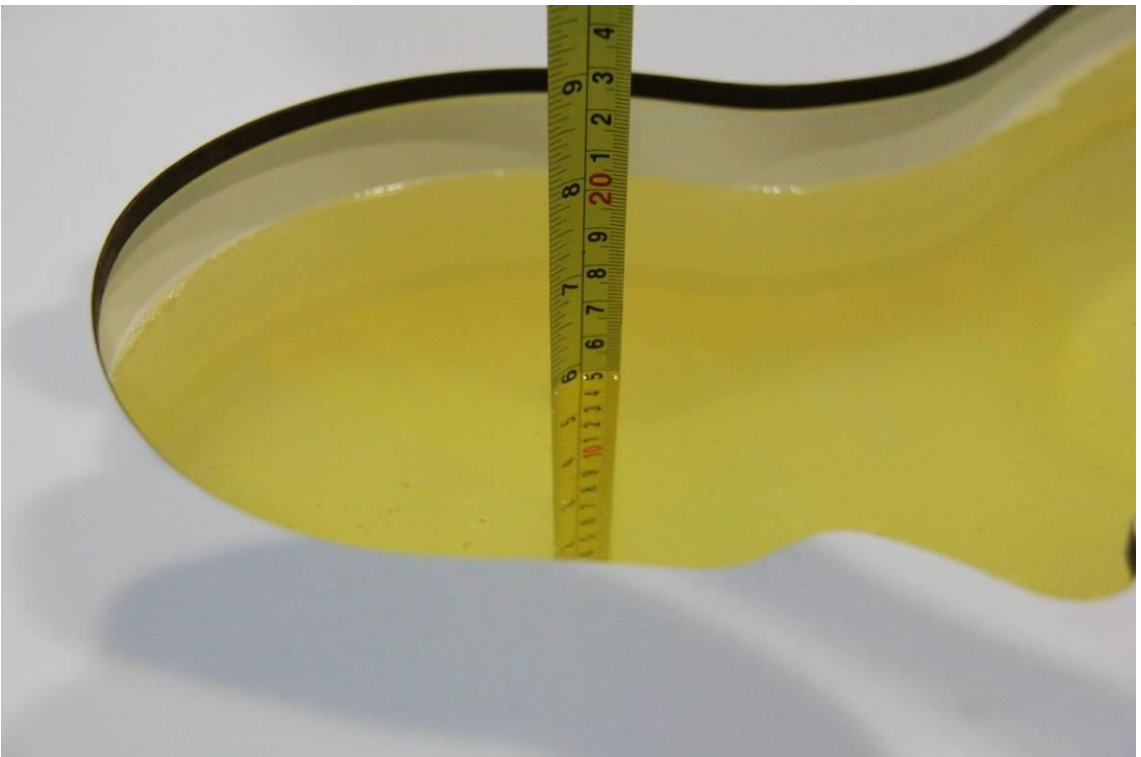

**Picture 7-6 Liquid depth in the Head Phantom (2300 MHz)**



Picture 7-7 Liquid depth in the Head Phantom (5GHz)



## 8 System verification

### 8.1 System Setup

In the simplified setup for system evaluation, the DUT is replaced by a calibrated dipole and the power source is replaced by a continuous wave that comes from a signal generator. The calibrated dipole must be placed beneath the flat phantom section of the SAM twin phantom with the correct distance holder. The distance holder should touch the phantom surface with a light pressure at the reference marking and be oriented parallel to the long side of the phantom. The equipment setup is shown below:

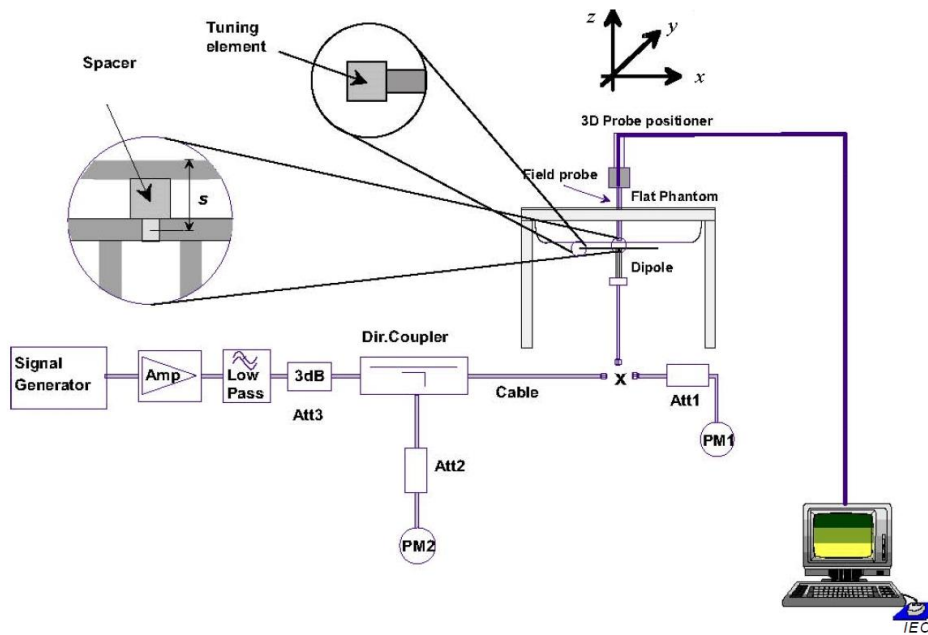

Picture 8.1 System Setup for System Evaluation



Picture 8.2 Photo of Dipole Setup

## 8.2 System Verification

SAR system verification is required to confirm measurement accuracy, according to the tissue dielectric media, probe calibration points and other system operating parameters required for measuring the SAR of a test device. The system verification must be performed for each frequency band and within the valid range of each probe calibration point required for testing the device.

The system verification results are required that the area scan estimated 1-g SAR is within 3% of the zoom scan 1-g SAR. The details are presented in annex B.

**Table 8.1: System Verification of Head**

Measurement Date (yyyy-mm-dd)	Frequency	Target value (W/kg)		Measured value (W/kg)		Deviation	
		10 g	1 g	10 g	1 g	10 g	1 g
		Average	Average	Average	Average	Average	Average
2021/2/13	750 MHz	5.53	8.47	5.44	8.64	-1.63%	2.01%
2021/2/14	835 MHz	6.25	9.60	6.2	9.72	-0.80%	1.25%
2021/2/15	1750 MHz	19.1	36.5	19.48	36.36	1.99%	-0.38%
2021/2/16	1900 MHz	20.6	39.6	20.52	39.96	-0.39%	0.91%
2021/2/17	2300 MHz	23.8	49.7	24.08	49.24	1.18%	-0.93%
2021/2/18	2450 MHz	24.5	52.5	24.56	52.32	0.24%	-0.34%
2021/2/19	5250 MHz	22.9	80.5	23.2	80.0	1.14%	-0.62%
2021/2/20	5600 MHz	23.6	83.3	23.5	83.5	-0.34%	0.26%
2021/2/21	5750 MHz	22.7	80.4	23.0	79.6	1.32%	-1.00%

## 9 Measurement Procedures

### 9.1 Tests to be performed

In order to determine the highest value of the peak spatial-average SAR of a handset, all device positions, configurations and operational modes shall be tested for each frequency band according to steps 1 to 3 below. A flowchart of the test process is shown in picture 9.1.

**Step 1:** The tests described in 9.2 shall be performed at the channel that is closest to the centre of the transmit frequency band ( $f_c$ ) for:

- a) all device positions (cheek and tilt, for both left and right sides of the SAM phantom, as described in annex D),
- b) all configurations for each device position in a), e.g., antenna extended and retracted, and
- c) all operational modes, e.g., analogue and digital, for each device position in a) and configuration in b) in each frequency band.

If more than three frequencies need to be tested according to 11.1 (i.e.,  $N_c > 3$ ), then all frequencies, configurations and modes shall be tested for all of the above test conditions.

**Step 2:** For the condition providing highest peak spatial-average SAR determined in Step 1, perform all tests described in 9.2 at all other test frequencies, i.e., lowest and highest frequencies. In addition, for all other conditions (device position, configuration and operational mode) where the peak spatial-average SAR value determined in Step 1 is within 3 dB of the applicable SAR limit, it is recommended that all other test frequencies shall be tested as well.

**Step 3:** Examine all data to determine the highest value of the peak spatial-average SAR found in Steps 1 to 2.

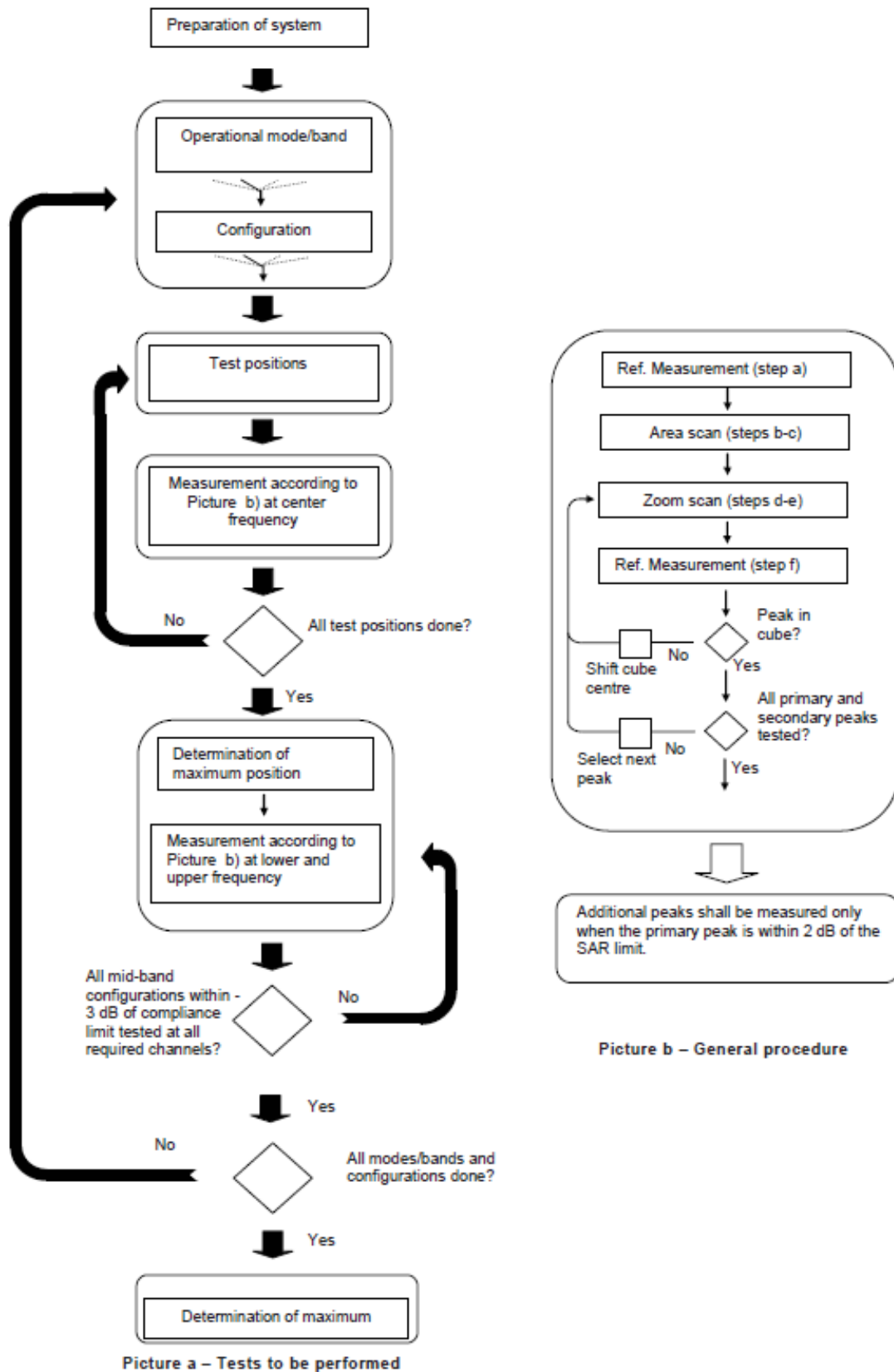

Picture 9.1 Block diagram of the tests to be performed

## 9.2 General Measurement Procedure

The area and zoom scan resolutions specified in the table below must be applied to the SAR measurements and fully documented in SAR reports to qualify for TCB approval. Probe boundary effect error compensation is required for measurements with the probe tip closer than half a probe tip diameter to the phantom surface. Both the probe tip diameter and sensor offset distance must satisfy measurement protocols; to ensure probe boundary effect errors are minimized and the higher fields closest to the phantom surface can be correctly measured and extrapolated to the phantom surface for computing 1-g SAR. Tolerances of the post-processing algorithms must be verified by the test laboratory for the scan resolutions used in the SAR measurements, according to the reference distribution functions specified in IEEE Std 1528-2003. The results should be documented as part of the system validation records and may be requested to support test results when all the measurement parameters in the following table are not satisfied.

		$\leq 3$ GHz	$> 3$ GHz
Maximum distance from closest measurement point (geometric center of probe sensors) to phantom surface		$5 \pm 1$ mm	$\frac{1}{2} \cdot \delta \cdot \ln(2) \pm 0.5$ mm
Maximum probe angle from probe axis to phantom surface normal at the measurement location		$30^\circ \pm 1^\circ$	$20^\circ \pm 1^\circ$
Maximum area scan spatial resolution: $\Delta x_{Area}$ , $\Delta y_{Area}$		$\leq 2$ GHz: $\leq 15$ mm 2 – 3 GHz: $\leq 12$ mm	3 – 4 GHz: $\leq 12$ mm 4 – 6 GHz: $\leq 10$ mm
		When the x or y dimension of the test device, in the measurement plane orientation, is smaller than the above, the measurement resolution must be $\leq$ the corresponding x or y dimension of the test device with at least one measurement point on the test device.	
Maximum zoom scan spatial resolution: $\Delta x_{Zoom}$ , $\Delta y_{Zoom}$		$\leq 2$ GHz: $\leq 8$ mm 2 – 3 GHz: $\leq 5$ mm*	3 – 4 GHz: $\leq 5$ mm* 4 – 6 GHz: $\leq 4$ mm*
Maximum zoom scan spatial resolution, normal to phantom surface	uniform grid: $\Delta z_{Zoom}(n)$	$\leq 5$ mm	3 – 4 GHz: $\leq 4$ mm 4 – 5 GHz: $\leq 3$ mm 5 – 6 GHz: $\leq 2$ mm
	graded grid	$\Delta z_{Zoom}(1)$ : between 1 <sup>st</sup> two points closest to phantom surface	$\leq 4$ mm
		$\Delta z_{Zoom}(n>1)$ : between subsequent points	$\leq 1.5 \cdot \Delta z_{Zoom}(n-1)$
Minimum zoom scan volume	x, y, z	$\geq 30$ mm	3 – 4 GHz: $\geq 28$ mm 4 – 5 GHz: $\geq 25$ mm 5 – 6 GHz: $\geq 22$ mm
Note: $\delta$ is the penetration depth of a plane-wave at normal incidence to the tissue medium; see draft standard IEEE P1528-2011 for details. * When zoom scan is required and the <i>reported</i> SAR from the area scan based 1-g SAR estimation procedures of KDB 447498 is $\leq 1.4$ W/kg, $\leq 8$ mm, $\leq 7$ mm and $\leq 5$ mm zoom scan resolution may be applied, respectively, for 2 GHz to 3 GHz, 3 GHz to 4 GHz and 4 GHz to 6 GHz.			

### 9.3 SAR Measurement for LTE

SAR tests for LTE are performed with a base station simulator, Rohde & Schwarz CMW500. Closed loop power control was used so the UE transmits with maximum output power during SAR testing. All powers were measured with the CMW 500.

It is performed for conducted power and SAR based on the KDB941225 D05.

SAR is evaluated separately according to the following procedures for the different test positions in each exposure condition – head, body, body-worn accessories and other use conditions. The procedures in the following subsections are applied separately to test each LTE frequency band.

#### 1) QPSK with 1 RB allocation

Start with the largest channel bandwidth and measure SAR for QPSK with 1 RB allocation, using the RB offset and required test channel combination with the highest maximum output power among RB offsets at the upper edge, middle and lower edge of each required test channel. When the reported SAR is  $\leq 0.8$  W/kg, testing of the remaining RB offset configurations and required test channels is not required for 1 RB allocation; otherwise, SAR is required for the remaining required test channels and only for the RB offset configuration with the highest output power for that channel. When the reported SAR of a required test channel is  $> 1.45$  W/kg, SAR is required for all three RB offset configurations for that required test channel.

#### 2) QPSK with 50% RB allocation

The procedures required for 1 RB allocation in 1) are applied to measure the SAR for QPSK with 50% RB allocation.

#### 3) QPSK with 100% RB allocation

For QPSK with 100% RB allocation, SAR is not required when the highest maximum output power for 100 % RB allocation is less than the highest maximum output power in 50% and 1 RB allocations and the highest reported SAR for 1 RB and 50% RB allocation in 1) and 2) are  $\leq 0.8$  W/kg. Otherwise, SAR is measured for the highest output power channel; and if the reported SAR is  $> 1.45$  W/kg, the remaining required test channels must also be tested.

### TDD test:

TDD testing is performed using guidance from FCC KDB 941225 D05 and the SAR test guidance provided in April 2013 TCB works hop notes. TDD is tested at the highest duty factor using UL-DL configuration 0 with special subframe configuration 6 and applying the FDD LTE procedures in KDB 941225 D05. SAR testing is performed using the extended cyclic prefix listed in 3GPP TS 36.211.

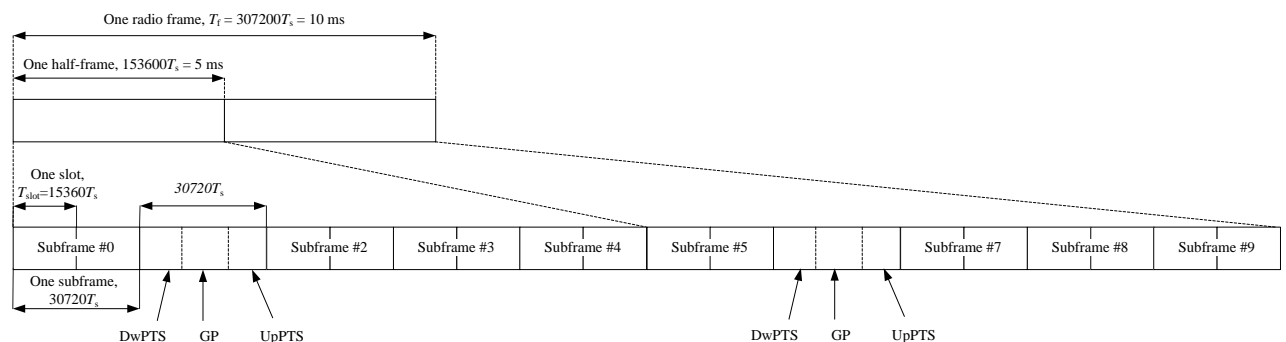

**Figure 9.2: Frame structure type 2 (for 5 ms switch-point periodicity)**

**Table 9.1: Configuration of special subframe (lengths of DwPTS/GP/UpPTS)**

Special subframe configuration	Normal cyclic prefix in downlink			Extended cyclic prefix in downlink		
	DwPTS	UpPTS		DwPTS	UpPTS	
		Normal cyclic prefix in uplink	Extended cyclic prefix in uplink		Normal cyclic prefix in uplink	Extended cyclic prefix in uplink
0	$6592 \cdot T_s$	$2192 \cdot T_s$	$2560 \cdot T_s$	$7680 \cdot T_s$	$2192 \cdot T_s$	$2560 \cdot T_s$
1	$19760 \cdot T_s$			$20480 \cdot T_s$		
2	$21952 \cdot T_s$			$23040 \cdot T_s$		
3	$24144 \cdot T_s$			$25600 \cdot T_s$		
4	$26336 \cdot T_s$			$7680 \cdot T_s$		
5	$6592 \cdot T_s$	$4384 \cdot T_s$	$5120 \cdot T_s$	$20480 \cdot T_s$	$4384 \cdot T_s$	$5120 \cdot T_s$
6	$19760 \cdot T_s$			$23040 \cdot T_s$		
7	$21952 \cdot T_s$			$12800 \cdot T_s$		
8	$24144 \cdot T_s$			-		
9	$13168 \cdot T_s$			-		

**Table 9.2: Uplink-downlink configurations**

Uplink-downlink configuration	Downlink-to-Uplink Switch-point periodicity	Subframe number									
		0	1	2	3	4	5	6	7	8	9
0	5 ms	D	S	U	U	U	D	S	U	U	U
1	5 ms	D	S	U	U	D	D	S	U	U	D
2	5 ms	D	S	U	D	D	D	S	U	D	D
3	10 ms	D	S	U	U	U	D	D	D	D	D
4	10 ms	D	S	U	U	D	D	D	D	D	D
5	10 ms	D	S	U	D	D	D	D	D	D	D
6	5 ms	D	S	U	U	U	D	S	U	U	D

Duty factor is calculated by:

$$\begin{aligned}
 \text{Duty factor} &= \text{uplink frame} \cdot 6 + \text{UpPTS} \cdot 2 / \text{one frame length} \\
 &= (30720 \cdot T_s \cdot 6 + 5120 \cdot T_s \cdot 2) / 307200 \cdot T_s \\
 &= 0.633
 \end{aligned}$$

#### **9.4 Wi-Fi Measurement Procedures for SAR**

Normal network operating configurations are not suitable for measuring the SAR of 802.11 transmitters in general. Unpredictable fluctuations in network traffic and antenna diversity conditions can introduce undesirable variations in SAR results. The SAR for these devices should be measured using chipset based test mode software to ensure that the results are consistent and reliable.

Chipset based test mode software is hardware dependent and generally varies among manufacturers. The device operating parameters established in a test mode for SAR measurements must be identical to those programmed in production units, including output power levels, amplifier gain settings and other RF performance tuning parameters. The test frequencies should correspond to actual channel frequencies defined for domestic use. SAR for devices with switched diversity should be measured with only one antenna transmitting at a time during each SAR measurement, according to a fixed modulation and data rate. The same data pattern should be used for all measurements.

#### **9.5 Power Drift**

To control the output power stability during the SAR test, DASY4 system calculates the power drift by measuring the E-field at the same location at the beginning and at the end of the measurement for each test position. These drift values can be found in section 14 labeled as: (Power Drift [dB]). This ensures that the power drift during one measurement is within 5%.



## 10 Area Scan Based 1-g SAR

### 10.1 Requirement of KDB

According to the KDB447498 D01, when the implementation is based the specific polynomial fit algorithm as presented at the 29th Bioelectromagnetics Society meeting (2007) and the estimated 1-gSAR is  $\leq 1.2$  W/kg, a zoom scan measurement is not required provided it is also not needed for any other purpose; for example, if the peak SAR location required for simultaneous transmission SAR test exclusion can be determined accurately by the SAR system or manually to discriminate between distinctive peaks and scattered noisy SAR distributions from area scans.

There must not be any warning or alert messages due to various measurement concerns identified by the SAR system; for example, noise in measurements, peaks too close to scan boundary, peaks are too sharp, spatial resolution and uncertainty issues etc. The SAR system verification must also demonstrate that the area scan estimated 1-g SAR is within 3% of the zoom scan 1-g SAR (See Annex B). When all the SAR results for each exposure condition in a frequency band and wireless mode are based on estimated 1-g SAR, the 1-g SAR for the highest SAR configuration must be determined by a zoom scan.

### 10.2 Fast SAR Algorithms

The approach is based on the area scan measurement applying a frequency dependent attenuation parameter. This attenuation parameter was empirically determined by analyzing a large number of phones. The MOTOROLA FAST SAR was developed and validated by the MOTOROLA Research Group in Ft. Lauderdale.

In the initial study, an approximation algorithm based on Linear fit was developed. The accuracy of the algorithm has been demonstrated across a broad frequency range (136-2450 MHz) and for both 1- and 10-g averaged SAR using a sample of 264 SAR measurements from 55 wireless handsets. For the sample size studied, the root-mean-squared errors of the algorithm are 1.2% and 5.8% for 1- and 10-g averaged SAR, respectively. The paper describing the algorithm in detail is expected to be published in August 2004 within the Special Issue of Transactions on MTT.

In the second step, the same research group optimized the fitting algorithm to an Polynomial fit whereby the frequency validity was extended to cover the range 30-6000MHz. Details of this study can be found in the BEMS 2007 Proceedings.

Both algorithms are implemented in DASYS software.

## 11 Conducted Output Power

There are two sets of tune-up power, Normal power and Low power. Low power for body test by proximity sensor in all bands. The detail of proximity sensor is presented in annex G.

### 11.1 LTE Measurement result

#### Maximum Target Power for Production Unit

Band	Tune up (dBm)	
	Normal Power	Low power
Band 2	23	19
Band 5	24	22
Band 12	23.5	22
Band 14	23.5	21.5
Band 30	22.5	18.5
Band 66	23	18

**Normal Power:**

LTEB2					
BANDWIDTH	Number of RBs	Frequency	QPSK	16QAM	
1.4MHz	1RB-High (5)	1909.3 (19193)	22.01	21.08	
		1880 (18900)	22.11	21.13	
		1850.7 (18607)	21.97	20.82	
	1RB-Middle (3)	1909.3 (19193)	22.22	21.13	
		1880 (18900)	22.00	21.06	
		1850.7 (18607)	21.99	20.55	
	1RB-Low (0)	1909.3 (19193)	22.11	21.10	
		1880 (18900)	21.93	21.06	
		1850.7 (18607)	21.90	20.67	
	3RB-High (3)	1909.3 (19193)	21.97	21.03	
		1880 (18900)	22.02	20.91	
		1850.7 (18607)	22.03	20.92	
	3RB-Middle (1)	1909.3 (19193)	21.98	20.98	
		1880 (18900)	22.07	20.97	
		1850.7 (18607)	22.13	20.89	
	3RB-Low (0)	1909.3 (19193)	22.02	21.03	
		1880 (18900)	21.90	20.83	
		1850.7 (18607)	21.98	20.83	
	6RB (0)	1909.3 (19193)	21.16	20.43	
		1880 (18900)	21.02	19.84	
		1850.7 (18607)	21.13	20.19	
	3MHz	1RB-High (14)	1908.5 (19185)	22.19	21.20
			1880 (18900)	21.95	21.11
			1851.5 (18615)	22.05	21.13
1RB-Middle (7)		1908.5 (19185)	22.25	21.44	
		1880 (18900)	22.22	21.17	
		1851.5 (18615)	22.09	21.44	
1RB-Low (0)		1908.5 (19185)	22.26	21.20	
		1880 (18900)	21.99	21.07	
		1851.5 (18615)	22.09	21.18	
8RB-High (7)		1908.5 (19185)	21.04	20.50	
		1880 (18900)	21.07	20.08	
		1851.5 (18615)	21.18	20.29	
8RB-Middle (4)		1908.5 (19185)	20.98	20.54	
		1880 (18900)	21.09	20.11	
		1851.5 (18615)	21.10	20.31	
8RB-Low (0)		1908.5 (19185)	20.95	20.53	

		1880 (18900)	21.05	20.07	
		1851.5 (18615)	21.05	20.26	
		15RB (0)	1908.5 (19185)	21.12	20.16
		1880 (18900)	21.05	20.06	
		1851.5 (18615)	21.08	20.30	
5MHz	1RB-High (24)	1907.5 (19175)	22.16	21.16	
		1880 (18900)	22.24	20.83	
		1852.5 (18625)	21.78	20.91	
	1RB-Middle (12)	1907.5 (19175)	22.33	21.34	
		1880 (18900)	22.35	20.96	
		1852.5 (18625)	22.05	21.14	
	1RB-Low (0)	1907.5 (19175)	22.27	21.23	
		1880 (18900)	22.21	20.93	
		1852.5 (18625)	21.83	21.02	
	12RB-High (13)	1907.5 (19175)	21.13	20.22	
		1880 (18900)	21.08	20.12	
		1852.5 (18625)	21.01	19.90	
	12RB-Middle (6)	1907.5 (19175)	21.24	20.18	
		1880 (18900)	21.11	20.15	
		1852.5 (18625)	21.16	19.95	
	12RB-Low (0)	1907.5 (19175)	21.17	20.16	
		1880 (18900)	21.13	20.18	
		1852.5 (18625)	21.10	19.98	
	25RB (0)	1907.5 (19175)	21.12	20.06	
		1880 (18900)	21.09	20.36	
		1852.5 (18625)	21.11	20.03	
	10MHz	1RB-High (49)	1905 (19150)	22.25	20.68
			1880 (18900)	22.35	21.24
			1855 (18650)	22.18	21.16
1RB-Middle (24)		1905 (19150)	22.70	21.42	
		1880 (18900)	22.54	21.72	
		1855 (18650)	22.26	21.08	
1RB-Low (0)		1905 (19150)	22.33	20.86	
		1880 (18900)	22.36	21.16	
		1855 (18650)	21.83	20.98	
25RB-High (25)		1905 (19150)	21.24	20.23	
		1880 (18900)	21.16	20.28	
		1855 (18650)	21.17	20.26	
25RB-Middle (12)		1905 (19150)	21.29	20.28	
		1880 (18900)	21.22	20.27	
		1855 (18650)	21.17	20.32	
25RB-Low (0)	1905 (19150)	21.14	20.20		

	50RB (0)	1880 (18900)	21.07	20.25	
		1855 (18650)	21.22	20.19	
		1905 (19150)	21.16	20.22	
		1880 (18900)	21.12	20.30	
		1855 (18650)	21.06	20.02	
15MHz	1RB-High (74)	1902.5 (19125)	21.82	21.01	
		1880 (18900)	22.05	21.32	
		1857.5 (18675)	22.01	20.90	
	1RB-Middle (37)	1902.5 (19125)	22.19	21.29	
		1880 (18900)	22.09	21.82	
		1857.5 (18675)	22.35	21.61	
	1RB-Low (0)	1902.5 (19125)	22.14	20.97	
		1880 (18900)	22.00	21.14	
		1857.5 (18675)	21.97	20.92	
	36RB-High (38)	1902.5 (19125)	21.18	20.31	
		1880 (18900)	21.10	20.29	
		1857.5 (18675)	21.16	20.27	
	36RB-Middle (19)	1902.5 (19125)	21.22	20.45	
		1880 (18900)	21.11	20.19	
		1857.5 (18675)	21.10	20.20	
	36RB-Low (0)	1902.5 (19125)	21.08	20.42	
		1880 (18900)	20.98	20.06	
		1857.5 (18675)	20.92	20.02	
	75RB (0)	1902.5 (19125)	21.10	20.22	
		1880 (18900)	21.08	20.18	
		1857.5 (18675)	21.00	20.09	
	20MHz	1RB-High (99)	1900 (19100)	22.23	21.02
			1880 (18900)	22.19	21.02
			1860 (18700)	22.01	21.01
1RB-Middle (50)		1900 (19100)	<b>22.43</b>	21.22	
		1880 (18900)	22.39	21.17	
		1860 (18700)	22.25	21.23	
1RB-Low (0)		1900 (19100)	22.18	21.01	
		1880 (18900)	22.02	21.03	
		1860 (18700)	22.03	21.01	
50RB-High (50)		1900 (19100)	21.39	20.18	
		1880 (18900)	21.14	20.28	
		1860 (18700)	21.31	20.16	
50RB-Middle (25)		1900 (19100)	<b>21.41</b>	20.42	
		1880 (18900)	21.25	20.17	
		1860 (18700)	21.35	20.31	
50RB-Low (0)	1900 (19100)	21.17	20.27		

	100RB (0)	1880 (18900)	21.15	20.16
		1860 (18700)	21.13	20.10
		1900 (19100)	21.23	20.22
		1880 (18900)	21.20	20.04
		1860 (18700)	21.11	20.10

LTEB5					
BANDWIDTH	Number of RBs	Frequency	QPSK	16QAM	
1.4MHz	1RB-High (5)	848.3 (20643)	22.52	21.74	
		836.5 (20525)	22.86	22.13	
		824.7 (20407)	22.58	21.81	
	1RB-Middle (3)	848.3 (20643)	22.65	21.78	
		836.5 (20525)	22.93	22.10	
		824.7 (20407)	22.72	21.83	
	1RB-Low (0)	848.3 (20643)	22.71	21.69	
		836.5 (20525)	22.79	22.19	
		824.7 (20407)	22.69	21.75	
	3RB-High (3)	848.3 (20643)	22.58	21.76	
		836.5 (20525)	22.83	21.94	
		824.7 (20407)	22.65	21.50	
	3RB-Middle (1)	848.3 (20643)	22.81	21.79	
		836.5 (20525)	22.69	21.92	
		824.7 (20407)	22.76	21.54	
	3RB-Low (0)	848.3 (20643)	22.67	21.90	
		836.5 (20525)	22.60	22.15	
		824.7 (20407)	22.71	21.50	
	6RB (0)	848.3 (20643)	21.62	20.65	
		836.5 (20525)	21.86	21.17	
		824.7 (20407)	21.80	20.37	
	3MHz	1RB-High (14)	847.5 (20635)	22.71	21.80
			836.5 (20525)	22.60	21.89
			825.5 (20415)	22.69	21.81
1RB-Middle (7)		847.5 (20635)	22.88	21.82	
		836.5 (20525)	22.94	21.94	
		825.5 (20415)	22.89	22.10	
1RB-Low (0)		847.5 (20635)	22.83	21.98	
		836.5 (20525)	22.90	21.85	
		825.5 (20415)	22.61	21.82	
8RB-High (7)		847.5 (20635)	21.92	20.86	
		836.5 (20525)	21.90	21.23	

		825.5 (20415)	21.79	20.82
	8RB-Middle (4)	847.5 (20635)	21.89	20.94
		836.5 (20525)	21.90	21.13
		825.5 (20415)	21.82	20.86
	8RB-Low (0)	847.5 (20635)	21.87	20.92
		836.5 (20525)	21.97	21.21
		825.5 (20415)	21.87	20.82
	15RB (0)	847.5 (20635)	21.84	20.81
		836.5 (20525)	21.90	21.16
		825.5 (20415)	21.88	20.86
5MHz	1RB-High (24)	846.5 (20625)	22.26	21.73
		836.5 (20525)	22.50	21.85
		826.5 (20425)	22.67	21.60
	1RB-Middle (12)	846.5 (20625)	22.50	21.37
		836.5 (20525)	22.71	21.96
		826.5 (20425)	22.93	21.87
	1RB-Low (0)	846.5 (20625)	22.27	21.01
		836.5 (20525)	22.51	21.76
		826.5 (20425)	22.75	21.69
	12RB-High (13)	846.5 (20625)	21.85	20.88
		836.5 (20525)	21.95	20.91
		826.5 (20425)	21.89	21.00
	12RB-Middle (6)	846.5 (20625)	21.79	20.84
		836.5 (20525)	21.88	20.93
		826.5 (20425)	21.95	21.06
	12RB-Low (0)	846.5 (20625)	21.80	20.86
		836.5 (20525)	21.96	20.94
		826.5 (20425)	21.86	20.98
	25RB (0)	846.5 (20625)	21.82	20.98
		836.5 (20525)	21.90	20.78
		826.5 (20425)	21.85	21.00
10MHz	1RB-High (49)	844 (20600)	22.70	21.75
		836.5 (20525)	22.66	21.51
		829 (20450)	22.58	21.77
	1RB-Middle (24)	844 (20600)	23.05	22.11
		836.5 (20525)	<b>23.18</b>	21.98
		829 (20450)	22.77	22.04
	1RB-Low (0)	844 (20600)	22.89	21.52
		836.5 (20525)	22.68	21.76
		829 (20450)	22.51	21.51
	25RB-High (25)	844 (20600)	21.79	20.91
		836.5 (20525)	21.89	20.86

		829 (20450)	21.85	20.76
	25RB-Middle (12)	844 (20600)	21.97	20.92
		836.5 (20525)	<b>21.99</b>	20.93
		829 (20450)	21.94	21.07
	25RB-Low (0)	844 (20600)	21.78	20.81
		836.5 (20525)	21.83	20.76
		829 (20450)	21.87	20.95
	50RB (0)	844 (20600)	21.77	20.76
		836.5 (20525)	21.89	20.92
		829 (20450)	21.82	20.89

LTEB12				
BANDWIDTH	Number of RBs	Frequency	QPSK	16QAM
1.4MHz	1RB-High (5)	715.3 (23173)	21.98	20.97
		707.5 (23095)	21.98	20.71
		699.7 (23017)	21.94	20.87
	1RB-Middle (3)	715.3 (23173)	21.96	21.02
		707.5 (23095)	21.93	20.70
		699.7 (23017)	21.82	20.76
	1RB-Low (0)	715.3 (23173)	21.94	20.91
		707.5 (23095)	22.00	20.60
		699.7 (23017)	21.74	20.90
	3RB-High (3)	715.3 (23173)	22.04	20.97
		707.5 (23095)	22.03	20.56
		699.7 (23017)	21.79	20.67
	3RB-Middle (1)	715.3 (23173)	22.05	21.03
		707.5 (23095)	22.03	20.55
		699.7 (23017)	21.97	20.59
	3RB-Low (0)	715.3 (23173)	22.01	20.97
		707.5 (23095)	21.99	20.50
		699.7 (23017)	22.02	20.66
	6RB (0)	715.3 (23173)	20.94	19.94
		707.5 (23095)	20.92	19.82
		699.7 (23017)	20.88	19.59
3MHz	1RB-High (14)	714.5 (23165)	22.14	20.95
		707.5 (23095)	21.93	20.53
		700.5 (23025)	22.10	20.75
	1RB-Middle (7)	714.5 (23165)	22.14	20.95
		707.5 (23095)	21.95	20.64
700.5 (23025)		21.88	20.61	



	1RB-Low (0)	714.5 (23165)	21.92	21.09
		707.5 (23095)	21.98	20.58
		700.5 (23025)	22.08	20.81
	8RB-High (7)	714.5 (23165)	20.98	19.96
		707.5 (23095)	21.01	19.78
		700.5 (23025)	20.97	20.40
	8RB-Middle (4)	714.5 (23165)	20.97	20.05
		707.5 (23095)	20.99	19.79
		700.5 (23025)	20.95	20.23
	8RB-Low (0)	714.5 (23165)	20.89	20.04
		707.5 (23095)	20.94	19.69
		700.5 (23025)	20.88	20.17
	15RB (0)	714.5 (23165)	20.97	20.13
		707.5 (23095)	21.01	19.73
		700.5 (23025)	20.96	19.99
5MHz	1RB-High (24)	713.5 (23155)	21.62	20.51
		707.5 (23095)	21.77	20.81
		701.5 (23035)	21.77	20.83
	1RB-Middle (12)	713.5 (23155)	22.21	20.71
		707.5 (23095)	21.85	20.57
		701.5 (23035)	22.09	21.42
	1RB-Low (0)	713.5 (23155)	21.66	20.56
		707.5 (23095)	21.83	20.50
		701.5 (23035)	21.62	20.70
	12RB-High (13)	713.5 (23155)	20.96	19.79
		707.5 (23095)	20.87	19.97
		701.5 (23035)	20.86	19.88
	12RB-Middle (6)	713.5 (23155)	21.05	19.90
		707.5 (23095)	20.88	19.90
		701.5 (23035)	20.99	19.97
	12RB-Low (0)	713.5 (23155)	21.04	19.94
		707.5 (23095)	20.84	19.70
		701.5 (23035)	20.81	19.82
	25RB (0)	713.5 (23155)	20.94	19.82
		707.5 (23095)	20.89	19.73
		701.5 (23035)	20.84	19.97
10MHz	1RB-High (49)	711 (23130)	21.63	20.85
		707.5 (23095)	21.76	20.50
		704 (23060)	21.84	20.82
	1RB-Middle (24)	711 (23130)	21.90	21.05
		707.5 (23095)	22.13	20.86
		704 (23060)	<b>22.43</b>	21.49

	1RB-Low (0)	711 (23130)	21.79	20.50
		707.5 (23095)	21.71	20.91
		704 (23060)	21.78	21.37
	25RB-High (25)	711 (23130)	20.94	19.96
		707.5 (23095)	20.90	19.97
		704 (23060)	<b>20.95</b>	19.78
	25RB-Middle (12)	711 (23130)	20.89	20.00
		707.5 (23095)	20.90	19.99
		704 (23060)	20.93	19.90
	25RB-Low (0)	711 (23130)	20.77	19.79
		707.5 (23095)	20.85	19.84
		704 (23060)	20.91	19.85
50RB (0)	711 (23130)	20.94	20.05	
	707.5 (23095)	20.88	19.90	
	704 (23060)	20.80	19.79	

LTEB14					
BANDWIDTH	Number of RBs	Frequency	QPSK	16QAM	
5MHz	1RB-High (24)	795.5 (23355)	23.08	22.03	
		793 (23330)	22.73	21.55	
		790.5 (23305)	22.69	21.63	
	1RB-Middle (12)	795.5 (23355)	23.43	22.07	
		793 (23330)	23.37	21.61	
		790.5 (23305)	23.24	22.37	
	1RB-Low (0)	795.5 (23355)	22.81	21.60	
		793 (23330)	23.03	21.54	
		790.5 (23305)	22.81	21.96	
	12RB-High (13)	795.5 (23355)	22.05	21.12	
		793 (23330)	22.02	20.79	
		790.5 (23305)	22.11	20.89	
	12RB-Middle (6)	795.5 (23355)	22.05	21.12	
		793 (23330)	22.11	21.07	
		790.5 (23305)	22.19	20.92	
	12RB-Low (0)	795.5 (23355)	22.00	21.01	
		793 (23330)	22.14	21.09	
		790.5 (23305)	22.13	21.14	
	25RB (0)	795.5 (23355)	22.05	21.05	
		793 (23330)	22.04	21.06	
		790.5 (23305)	22.09	20.94	
	10MHz	1RB-High (49)	793 (23330)	23.13	22.19
		1RB-Middle (24)	793 (23330)	<b>23.35</b>	22.26

	1RB-Low (0)	793 (23330)	23.29	22.10
	25RB-High (25)	793 (23330)	22.16	21.16
	25RB-Middle (12)	793 (23330)	22.13	21.23
	25RB-Low (0)	793 (23330)	<b>22.19</b>	21.17
	50RB (0)	793 (23330)	22.08	21.06

LTE B30				
BANDWIDTH	Number LTEf RBs	Frequency	QPSK	16QAM
5MHz	1RB-High (24)	2312.5 (27735)	21.00	19.82
		2310 (27710)	21.13	19.63
		2307.5 (27685)	21.00	20.22
	1RB-Middle (12)	2312.5 (27735)	21.34	20.11
		2310 (27710)	21.51	20.13
		2307.5 (27685)	21.33	20.53
	1RB-LLTEw (0)	2312.5 (27735)	21.30	19.96
		2310 (27710)	21.31	19.87
		2307.5 (27685)	20.98	20.37
	12RB-High (13)	2312.5 (27735)	20.18	19.12
		2310 (27710)	20.27	19.15
		2307.5 (27685)	20.27	19.28
	12RB-Middle (6)	2312.5 (27735)	20.33	19.19
		2310 (27710)	20.31	19.29
		2307.5 (27685)	20.33	19.34
	12RB-LLTEw (0)	2312.5 (27735)	20.38	19.13
		2310 (27710)	20.31	19.26
		2307.5 (27685)	20.29	19.25
	25RB (0)	2312.5 (27735)	20.28	19.15
		2310 (27710)	20.32	19.29
		2307.5 (27685)	20.33	19.46
10MHz	1RB-High (49)	2310 (27710)	21.00	19.94
	1RB-Middle (24)	2310 (27710)	<b>21.57</b>	20.42
	1RB-LLTEw (0)	2310 (27710)	21.26	19.94
	25RB-High (25)	2310 (27710)	20.33	19.30
	25RB-Middle (12)	2310 (27710)	<b>20.36</b>	19.56
	25RB-LLTEw (0)	2310 (27710)	20.25	19.54
	50RB (0)	2310 (27710)	20.22	19.24

LTEB66					
BANDWIDTH	Number of RBs	Frequency	QPSK	16QAM	
1.4MHz	1RB-High (5)	1779.3 (132665)	21.24	20.29	
		1745 (132322)	21.12	20.01	
		1710.7 (131979)	21.01	20.27	
	1RB-Middle (3)	1779.3 (132665)	21.33	20.07	
		1745 (132322)	21.22	20.02	
		1710.7 (131979)	21.01	20.15	
	1RB-Low (0)	1779.3 (132665)	21.27	20.04	
		1745 (132322)	21.17	20.02	
		1710.7 (131979)	21.09	20.14	
	3RB-High (3)	1779.3 (132665)	21.16	20.01	
		1745 (132322)	21.13	20.05	
		1710.7 (131979)	21.09	20.30	
	3RB-Middle (1)	1779.3 (132665)	21.27	20.07	
		1745 (132322)	21.16	20.03	
		1710.7 (131979)	21.11	20.43	
	3RB-Low (0)	1779.3 (132665)	21.21	20.04	
		1745 (132322)	21.11	20.02	
		1710.7 (131979)	21.05	20.40	
	6RB (0)	1779.3 (132665)	20.21	19.15	
		1745 (132322)	20.19	19.30	
		1710.7 (131979)	20.32	19.50	
	3MHz	1RB-High (14)	1778.5 (132657)	21.23	20.49
			1745 (132322)	21.15	20.16
			1711.5 (131987)	21.03	20.19
		1RB-Middle (7)	1778.5 (132657)	21.63	20.30
			1745 (132322)	21.20	20.68
			1711.5 (131987)	21.08	20.23
1RB-Low (0)		1778.5 (132657)	21.23	20.21	
		1745 (132322)	21.52	20.48	
		1711.5 (131987)	21.24	20.16	
8RB-High (7)		1778.5 (132657)	20.30	19.20	
		1745 (132322)	20.28	19.43	
		1711.5 (131987)	20.22	19.63	
8RB-Middle (4)		1778.5 (132657)	20.29	19.19	
		1745 (132322)	20.28	19.45	
		1711.5 (131987)	20.24	19.23	
8RB-Low (0)		1778.5 (132657)	20.22	19.28	
		1745 (132322)	20.26	19.44	
		1711.5 (131987)	20.23	19.22	

	15RB (0)	1778.5 (132657)	20.32	19.25	
		1745 (132322)	20.23	19.34	
		1711.5 (131987)	20.23	19.11	
5MHz	1RB-High (24)	1777.5 (132647)	21.02	20.23	
		1745 (132322)	21.07	20.01	
		1712.5 (131997)	21.27	20.02	
	1RB-Middle (12)	1777.5 (132647)	21.01	20.35	
		1745 (132322)	21.10	20.02	
		1712.5 (131997)	21.26	20.03	
	1RB-Low (0)	1777.5 (132647)	21.02	20.15	
		1745 (132322)	21.03	20.01	
		1712.5 (131997)	21.15	20.01	
	12RB-High (13)	1777.5 (132647)	20.21	19.33	
		1745 (132322)	20.13	19.03	
		1712.5 (131997)	20.30	19.04	
	12RB-Middle (6)	1777.5 (132647)	20.20	19.33	
		1745 (132322)	20.17	19.07	
		1712.5 (131997)	20.19	19.00	
	12RB-Low (0)	1777.5 (132647)	20.22	19.25	
		1745 (132322)	20.16	19.07	
		1712.5 (131997)	20.15	19.01	
	25RB (0)	1777.5 (132647)	20.26	19.21	
		1745 (132322)	20.25	19.13	
		1712.5 (131997)	20.28	19.34	
	10MHz	1RB-High (49)	1775 (132622)	21.27	20.30
			1745 (132322)	21.11	20.47
			1715 (132022)	21.11	20.34
1RB-Middle (24)		1775 (132622)	21.14	20.33	
		1745 (132322)	21.31	20.46	
		1715 (132022)	21.40	20.89	
1RB-Low (0)		1775 (132622)	21.08	20.01	
		1745 (132322)	21.20	20.20	
		1715 (132022)	21.12	20.15	
25RB-High (25)		1775 (132622)	20.30	19.34	
		1745 (132322)	20.34	19.48	
		1715 (132022)	20.40	19.31	
25RB-Middle (12)		1775 (132622)	20.32	19.37	
		1745 (132322)	20.40	19.39	
		1715 (132022)	20.40	19.29	
25RB-Low (0)		1775 (132622)	20.22	19.31	
		1745 (132322)	20.39	19.22	
		1715 (132022)	20.23	19.14	

		1775 (132622)	20.33	19.35	
	50RB (0)	1745 (132322)	20.30	19.13	
		1715 (132022)	20.32	19.23	
15MHz	1RB-High (74)	1772.5 (132597)	21.14	20.06	
		1745 (132322)	21.25	20.91	
		1717.5 (132047)	21.37	20.46	
	1RB-Middle (37)	1772.5 (132597)	21.50	20.33	
		1745 (132322)	21.51	21.09	
		1717.5 (132047)	21.39	20.84	
	1RB-Low (0)	1772.5 (132597)	21.25	20.02	
		1745 (132322)	21.17	20.97	
		1717.5 (132047)	21.25	20.18	
	36RB-High (38)	1772.5 (132597)	20.32	19.21	
		1745 (132322)	20.32	19.37	
		1717.5 (132047)	20.28	19.27	
	36RB-Middle (19)	1772.5 (132597)	20.33	19.24	
		1745 (132322)	20.31	19.34	
		1717.5 (132047)	20.37	19.26	
	36RB-Low (0)	1772.5 (132597)	20.27	19.40	
		1745 (132322)	20.45	19.30	
		1717.5 (132047)	20.21	19.11	
	75RB (0)	1772.5 (132597)	20.26	19.27	
		1745 (132322)	20.41	19.29	
		1717.5 (132047)	20.28	19.20	
	20MHz	1RB-High (99)	1770 (132572)	21.15	20.28
			1745 (132322)	21.07	20.10
			1720 (132072)	21.06	20.42
		1RB-Middle (50)	1770 (132572)	<b>21.47</b>	20.36
			1745 (132322)	21.38	20.21
			1720 (132072)	21.22	20.69
1RB-Low (0)		1770 (132572)	21.19	20.02	
		1745 (132322)	21.05	20.18	
		1720 (132072)	21.02	20.01	
50RB-High (50)		1770 (132572)	20.33	19.33	
		1745 (132322)	<b>20.47</b>	19.48	
		1720 (132072)	20.37	19.49	
50RB-Middle (25)		1770 (132572)	20.31	19.30	
		1745 (132322)	20.41	19.35	
		1720 (132072)	20.34	19.44	
50RB-Low (0)		1770 (132572)	20.27	19.17	
		1745 (132322)	20.46	19.38	
		1720 (132072)	20.31	19.23	

	100RB (0)	1770 (132572)	20.24	19.25
		1745 (132322)	20.40	19.45
		1720 (132072)	20.35	19.39

**Low power:**

LTEB2				
BANDWIDTH	Number of RBs	Frequency	QPSK	16QAM
1.4MHz	1RB-High (5)	1909.3 (19193)	18.00	17.20
		1880 (18900)	18.22	17.43
		1850.7 (18607)	18.23	17.29
	1RB-Middle (3)	1909.3 (19193)	18.31	17.23
		1880 (18900)	18.26	17.38
		1850.7 (18607)	18.27	17.31
	1RB-Low (0)	1909.3 (19193)	18.26	17.20
		1880 (18900)	18.24	17.43
		1850.7 (18607)	18.20	17.26
	3RB-High (3)	1909.3 (19193)	18.21	17.42
		1880 (18900)	18.17	17.39
		1850.7 (18607)	18.21	17.01
	3RB-Middle (1)	1909.3 (19193)	18.46	17.39
		1880 (18900)	18.33	17.51
		1850.7 (18607)	18.25	17.06
	3RB-Low (0)	1909.3 (19193)	18.32	17.44
		1880 (18900)	18.29	17.57
		1850.7 (18607)	18.21	17.02
	6RB (0)	1909.3 (19193)	17.26	16.18
		1880 (18900)	17.32	16.47
		1850.7 (18607)	17.28	15.90
3MHz	1RB-High (14)	1908.5 (19185)	18.01	17.10
		1880 (18900)	18.29	17.16
		1851.5 (18615)	18.19	17.34
	1RB-Middle (7)	1908.5 (19185)	18.28	17.66
		1880 (18900)	18.33	17.32
		1851.5 (18615)	18.22	17.37
	1RB-Low (0)	1908.5 (19185)	18.15	17.29
		1880 (18900)	18.25	17.25
		1851.5 (18615)	18.12	17.27
8RB-High (7)	1908.5 (19185)	17.24	16.28	
	1880 (18900)	17.24	16.57	
	1851.5 (18615)	17.19	16.10	

	8RB-Middle (4)	1908.5 (19185)	17.28	16.34	
		1880 (18900)	17.28	16.60	
		1851.5 (18615)	17.19	16.04	
	8RB-Low (0)	1908.5 (19185)	17.16	16.32	
		1880 (18900)	17.26	16.48	
		1851.5 (18615)	17.25	16.08	
	15RB (0)	1908.5 (19185)	17.16	15.99	
		1880 (18900)	17.27	16.23	
		1851.5 (18615)	17.27	16.27	
5MHz	1RB-High (24)	1907.5 (19175)	18.00	17.21	
		1880 (18900)	18.12	16.91	
		1852.5 (18625)	18.09	17.12	
	1RB-Middle (12)	1907.5 (19175)	18.09	17.29	
		1880 (18900)	18.32	16.81	
		1852.5 (18625)	18.20	17.15	
	1RB-Low (0)	1907.5 (19175)	17.99	17.14	
		1880 (18900)	18.23	16.64	
		1852.5 (18625)	18.00	16.87	
	12RB-High (13)	1907.5 (19175)	17.19	16.18	
		1880 (18900)	17.21	16.14	
		1852.5 (18625)	17.16	16.14	
	12RB-Middle (6)	1907.5 (19175)	17.25	16.23	
		1880 (18900)	17.13	16.16	
		1852.5 (18625)	17.18	16.16	
	12RB-Low (0)	1907.5 (19175)	17.16	16.14	
		1880 (18900)	17.19	16.01	
		1852.5 (18625)	17.13	16.10	
	25RB (0)	1907.5 (19175)	17.21	16.03	
		1880 (18900)	17.30	16.25	
		1852.5 (18625)	17.22	16.13	
	10MHz	1RB-High (49)	1905 (19150)	18.21	17.25
			1880 (18900)	18.20	17.40
			1855 (18650)	18.58	17.29
1RB-Middle (24)		1905 (19150)	18.51	17.30	
		1880 (18900)	18.35	17.73	
		1855 (18650)	18.80	17.90	
1RB-Low (0)		1905 (19150)	18.04	16.76	
		1880 (18900)	17.95	17.17	
		1855 (18650)	18.44	17.08	
25RB-High (25)		1905 (19150)	17.22	15.96	
		1880 (18900)	17.31	16.32	
		1855 (18650)	17.30	16.33	



	25RB-Middle (12)	1905 (19150)	17.25	16.06	
		1880 (18900)	17.27	16.38	
		1855 (18650)	17.33	16.34	
	25RB-Low (0)	1905 (19150)	17.18	16.00	
		1880 (18900)	17.12	16.22	
		1855 (18650)	17.19	16.13	
	50RB (0)	1905 (19150)	17.25	15.96	
		1880 (18900)	17.25	16.14	
		1855 (18650)	17.19	16.11	
15MHz	1RB-High (74)	1902.5 (19125)	18.21	17.41	
		1880 (18900)	18.24	17.21	
		1857.5 (18675)	18.25	17.14	
	1RB-Middle (37)	1902.5 (19125)	18.46	17.87	
		1880 (18900)	18.61	17.75	
		1857.5 (18675)	18.44	17.27	
	1RB-Low (0)	1902.5 (19125)	18.29	17.72	
		1880 (18900)	18.40	16.96	
		1857.5 (18675)	18.29	16.67	
	36RB-High (38)	1902.5 (19125)	17.20	16.02	
		1880 (18900)	17.25	16.13	
		1857.5 (18675)	17.24	16.35	
	36RB-Middle (19)	1902.5 (19125)	17.24	16.05	
		1880 (18900)	17.23	16.17	
		1857.5 (18675)	17.27	16.40	
	36RB-Low (0)	1902.5 (19125)	17.21	16.01	
		1880 (18900)	17.22	16.03	
		1857.5 (18675)	17.20	16.19	
	75RB (0)	1902.5 (19125)	17.11	16.01	
		1880 (18900)	17.25	16.13	
		1857.5 (18675)	17.26	16.27	
	20MHz	1RB-High (99)	1900 (19100)	18.34	17.10
			1880 (18900)	18.19	17.16
			1860 (18700)	17.91	16.98
		1RB-Middle (50)	1900 (19100)	18.64	17.25
			1880 (18900)	18.52	17.21
			1860 (18700)	18.45	17.44
1RB-Low (0)		1900 (19100)	18.40	17.04	
		1880 (18900)	18.12	17.08	
		1860 (18700)	17.80	16.91	
50RB-High (50)		1900 (19100)	17.30	16.28	
		1880 (18900)	17.40	16.27	
		1860 (18700)	17.21	16.10	

	50RB-Middle (25)	1900 (19100)	17.36	16.27
		1880 (18900)	17.41	16.24
		1860 (18700)	17.38	16.38
	50RB-Low (0)	1900 (19100)	17.36	16.29
		1880 (18900)	17.25	16.20
		1860 (18700)	17.29	16.27
	100RB (0)	1900 (19100)	17.32	16.13
		1880 (18900)	17.37	16.26
		1860 (18700)	17.33	16.26

LTEB5					
BANDWIDTH	Number of RBs	Frequency	QPSK	16QAM	
1.4MHz	1RB-High (5)	848.3 (20643)	20.75	20.02	
		836.5 (20525)	20.73	19.88	
		824.7 (20407)	20.68	19.78	
	1RB-Middle (3)	848.3 (20643)	20.97	20.03	
		836.5 (20525)	20.81	19.79	
		824.7 (20407)	20.89	19.65	
	1RB-Low (0)	848.3 (20643)	20.90	19.97	
		836.5 (20525)	20.82	19.87	
		824.7 (20407)	20.60	19.60	
	3RB-High (3)	848.3 (20643)	20.71	20.02	
		836.5 (20525)	20.93	19.75	
		824.7 (20407)	20.75	19.47	
	3RB-Middle (1)	848.3 (20643)	20.73	19.96	
		836.5 (20525)	20.89	19.65	
		824.7 (20407)	20.85	19.50	
	3RB-Low (0)	848.3 (20643)	20.68	20.02	
		836.5 (20525)	20.79	19.66	
		824.7 (20407)	20.79	19.45	
	6RB (0)	848.3 (20643)	19.87	18.97	
		836.5 (20525)	19.87	19.17	
		824.7 (20407)	19.82	18.51	
	3MHz	1RB-High (14)	847.5 (20635)	20.73	19.85
			836.5 (20525)	21.05	19.94
			825.5 (20415)	20.94	19.75
1RB-Middle (7)		847.5 (20635)	20.90	19.88	
		836.5 (20525)	21.13	19.92	
		825.5 (20415)	21.13	19.73	
1RB-Low (0)		847.5 (20635)	20.79	20.05	
		836.5 (20525)	21.04	19.85	

		825.5 (20415)	20.99	19.60
	8RB-High (7)	847.5 (20635)	19.88	19.03
		836.5 (20525)	19.85	18.92
		825.5 (20415)	19.82	19.18
	8RB-Middle (4)	847.5 (20635)	19.91	19.19
		836.5 (20525)	19.88	18.79
		825.5 (20415)	19.78	19.10
	8RB-Low (0)	847.5 (20635)	19.89	18.90
		836.5 (20525)	19.86	18.86
		825.5 (20415)	19.79	19.15
	15RB (0)	847.5 (20635)	19.80	19.01
		836.5 (20525)	19.78	18.68
		825.5 (20415)	19.73	18.79
5MHz	1RB-High (24)	846.5 (20625)	20.63	19.95
		836.5 (20525)	20.65	19.67
		826.5 (20425)	20.46	19.69
	1RB-Middle (12)	846.5 (20625)	20.66	19.80
		836.5 (20525)	20.94	19.85
		826.5 (20425)	20.74	19.72
	1RB-Low (0)	846.5 (20625)	20.48	19.55
		836.5 (20525)	20.49	19.59
		826.5 (20425)	20.79	19.43
	12RB-High (13)	846.5 (20625)	19.94	18.77
		836.5 (20525)	19.85	18.96
		826.5 (20425)	19.75	18.71
	12RB-Middle (6)	846.5 (20625)	19.90	18.81
		836.5 (20525)	19.87	18.97
		826.5 (20425)	19.82	18.77
	12RB-Low (0)	846.5 (20625)	19.84	18.77
		836.5 (20525)	19.76	18.78
		826.5 (20425)	19.65	18.78
25RB (0)	846.5 (20625)	19.94	18.89	
	836.5 (20525)	19.80	18.81	
	826.5 (20425)	19.63	18.88	
10MHz	1RB-High (49)	844 (20600)	20.69	19.82
		836.5 (20525)	20.56	19.69
		829 (20450)	20.57	19.14
	1RB-Middle (24)	844 (20600)	21.11	20.25
		836.5 (20525)	21.03	19.88
		829 (20450)	20.88	19.87
1RB-Low (0)	844 (20600)	20.56	19.43	
	836.5 (20525)	20.38	19.22	

		829 (20450)	20.52	19.35
25RB-High (25)		844 (20600)	19.77	18.88
		836.5 (20525)	19.93	19.04
		829 (20450)	19.73	18.70
25RB-Middle (12)		844 (20600)	19.80	18.91
		836.5 (20525)	19.91	19.13
		829 (20450)	19.80	18.86
25RB-Low (0)		844 (20600)	19.74	18.75
		836.5 (20525)	19.75	18.96
		829 (20450)	19.61	18.76
50RB (0)		844 (20600)	19.74	18.72
		836.5 (20525)	19.81	18.74
		829 (20450)	19.73	18.66

LTEB12					
BANDWIDTH	Number of RBs	Frequency	QPSK	16QAM	
1.4MHz	1RB-High (5)	715.3 (23173)	20.80	19.76	
		707.5 (23095)	20.48	19.71	
		699.7 (23017)	20.66	19.68	
	1RB-Middle (3)	715.3 (23173)	20.88	19.86	
		707.5 (23095)	20.57	19.59	
		699.7 (23017)	20.74	19.79	
	1RB-Low (0)	715.3 (23173)	20.88	19.88	
		707.5 (23095)	20.53	19.72	
		699.7 (23017)	20.70	19.88	
	3RB-High (3)	715.3 (23173)	20.65	19.88	
		707.5 (23095)	20.82	19.54	
		699.7 (23017)	20.79	19.94	
	3RB-Middle (1)	715.3 (23173)	20.75	20.02	
		707.5 (23095)	20.79	19.53	
		699.7 (23017)	20.82	19.87	
	3RB-Low (0)	715.3 (23173)	20.72	19.92	
		707.5 (23095)	20.62	19.39	
		699.7 (23017)	20.89	19.86	
	6RB (0)	715.3 (23173)	20.03	18.91	
		707.5 (23095)	19.89	18.75	
		699.7 (23017)	19.95	18.66	
	3MHz	1RB-High (14)	714.5 (23165)	20.82	19.73
			707.5 (23095)	21.05	19.46
			700.5 (23025)	20.74	19.87
1RB-Middle (7)		714.5 (23165)	20.96	19.94	

	1RB-Low (0)	707.5 (23095)	21.08	19.53	
		700.5 (23025)	20.79	20.19	
		714.5 (23165)	20.89	20.01	
	8RB-High (7)	707.5 (23095)	20.85	19.71	
		700.5 (23025)	20.81	19.91	
		714.5 (23165)	19.90	18.67	
	8RB-Middle (4)	707.5 (23095)	20.00	19.16	
		700.5 (23025)	19.94	18.88	
		714.5 (23165)	19.95	18.74	
	8RB-Low (0)	707.5 (23095)	20.00	18.79	
		700.5 (23025)	20.00	18.86	
		714.5 (23165)	19.99	18.69	
	15RB (0)	707.5 (23095)	19.99	18.71	
		700.5 (23025)	19.89	18.84	
		714.5 (23165)	19.99	18.69	
5MHz	1RB-High (24)	714.5 (23165)	19.99	18.71	
		707.5 (23095)	20.02	18.82	
		700.5 (23025)	19.92	18.92	
	1RB-Middle (12)	713.5 (23155)	20.73	19.38	
		707.5 (23095)	20.51	19.80	
		701.5 (23035)	20.74	19.46	
	1RB-Low (0)	713.5 (23155)	21.01	19.89	
		707.5 (23095)	20.57	20.09	
		701.5 (23035)	20.85	19.97	
	12RB-High (13)	713.5 (23155)	20.79	19.67	
		707.5 (23095)	20.50	19.80	
		701.5 (23035)	20.55	19.50	
	12RB-Middle (6)	713.5 (23155)	19.72	18.69	
		707.5 (23095)	19.76	18.80	
		701.5 (23035)	19.72	18.85	
	12RB-Low (0)	713.5 (23155)	19.88	18.84	
		707.5 (23095)	19.82	18.78	
		701.5 (23035)	19.97	19.08	
	25RB (0)	713.5 (23155)	19.85	18.90	
		707.5 (23095)	19.78	18.74	
		701.5 (23035)	19.83	18.94	
	10MHz	1RB-High (49)	713.5 (23155)	19.77	18.68
			707.5 (23095)	19.89	18.82
			701.5 (23035)	19.78	18.82
1RB-Middle (24)		711 (23130)	20.94	19.72	
	1RB-High (49)	707.5 (23095)	20.64	19.75	
		704 (23060)	20.77	19.92	
		711 (23130)	20.95	20.46	

		707.5 (23095)	20.93	19.92
		704 (23060)	20.96	20.09
1RB-Low (0)		711 (23130)	20.87	19.74
		707.5 (23095)	20.64	19.36
		704 (23060)	20.71	19.43
25RB-High (25)		711 (23130)	19.87	18.93
		707.5 (23095)	19.94	18.91
		704 (23060)	19.83	18.94
25RB-Middle (12)		711 (23130)	19.93	19.11
		707.5 (23095)	19.87	18.80
		704 (23060)	19.83	18.91
25RB-Low (0)		711 (23130)	19.85	18.86
		707.5 (23095)	19.77	18.88
		704 (23060)	19.68	18.85
50RB (0)		711 (23130)	19.90	18.93
		707.5 (23095)	19.80	18.82
		704 (23060)	19.88	18.88

LTEB14				
BANDWIDTH	Number of RBs	Frequency	QPSK	16QAM
5MHz	1RB-High (24)	795.5 (23355)	19.82	18.82
		793 (23330)	19.74	18.86
		790.5 (23305)	19.86	18.50
	1RB-Middle (12)	795.5 (23355)	19.93	18.51
		793 (23330)	20.01	19.11
		790.5 (23305)	20.11	18.59
	1RB-Low (0)	795.5 (23355)	19.73	18.51
		793 (23330)	19.98	19.03
		790.5 (23305)	19.97	18.52
	12RB-High (13)	795.5 (23355)	19.06	17.92
		793 (23330)	18.93	17.77
		790.5 (23305)	18.95	17.72
	12RB-Middle (6)	795.5 (23355)	18.94	17.80
		793 (23330)	18.97	17.81
		790.5 (23305)	19.06	17.99
	12RB-Low (0)	795.5 (23355)	18.88	17.66
		793 (23330)	18.89	17.84
		790.5 (23305)	18.99	18.02
	25RB (0)	795.5 (23355)	19.01	17.92
		793 (23330)	18.88	17.83

		790.5 (23305)	18.98	17.84
10MHz	1RB-High (49)	793 (23330)	20.05	18.68
	1RB-Middle (24)	793 (23330)	20.33	19.25
	1RB-Low (0)	793 (23330)	20.26	19.16
	25RB-High (25)	793 (23330)	19.04	18.03
	25RB-Middle (12)	793 (23330)	19.04	18.02
	25RB-Low (0)	793 (23330)	19.02	18.10
	50RB (0)	793 (23330)	18.96	17.97

LTEB30					
BANDWIDTH	Number of RBs	Frequency	QPSK	16QAM	
5MHz	1RB-High (24)	2312.5 (27735)	16.51	16.15	
		2310 (27710)	16.96	16.09	
		2307.5 (27685)	17.05	15.86	
	1RB-Middle (12)	2312.5 (27735)	17.16	16.41	
		2310 (27710)	17.21	16.22	
		2307.5 (27685)	17.20	16.05	
	1RB-Low (0)	2312.5 (27735)	16.88	16.06	
		2310 (27710)	16.78	16.00	
		2307.5 (27685)	17.04	15.67	
	12RB-High (13)	2312.5 (27735)	16.02	14.90	
		2310 (27710)	16.12	15.13	
		2307.5 (27685)	15.92	14.94	
	12RB-Middle (6)	2312.5 (27735)	16.02	15.01	
		2310 (27710)	16.12	15.12	
		2307.5 (27685)	16.06	15.12	
	12RB-Low (0)	2312.5 (27735)	15.96	14.96	
		2310 (27710)	16.06	15.11	
		2307.5 (27685)	16.00	15.15	
	25RB (0)	2312.5 (27735)	16.10	15.25	
		2310 (27710)	16.03	14.96	
		2307.5 (27685)	15.99	15.14	
	10MHz	1RB-High (49)	2310 (27710)	17.04	16.14
		1RB-Middle (24)	2310 (27710)	17.33	16.28
		1RB-Low (0)	2310 (27710)	17.03	16.01
		25RB-High (25)	2310 (27710)	16.11	15.01
		25RB-Middle (12)	2310 (27710)	16.07	15.12
		25RB-Low (0)	2310 (27710)	16.09	15.09
50RB (0)		2310 (27710)	16.06	15.10	

LTEB66					
BANDWIDTH	Number of RBs	Frequency	QPSK	16QAM	
1.4MHz	1RB-High (5)	1779.3 (132665)	17.16	15.92	
		1745 (132322)	17.07	15.95	
		1710.7 (131979)	16.98	16.01	
	1RB-Middle (3)	1779.3 (132665)	17.16	15.87	
		1745 (132322)	17.10	15.91	
		1710.7 (131979)	17.00	16.07	
	1RB-Low (0)	1779.3 (132665)	17.18	15.83	
		1745 (132322)	17.17	16.06	
		1710.7 (131979)	16.86	15.98	
	3RB-High (3)	1779.3 (132665)	17.10	15.96	
		1745 (132322)	17.15	15.81	
		1710.7 (131979)	17.16	15.65	
	3RB-Middle (1)	1779.3 (132665)	17.10	16.02	
		1745 (132322)	17.16	15.75	
		1710.7 (131979)	17.23	15.55	
	3RB-Low (0)	1779.3 (132665)	17.15	15.98	
		1745 (132322)	17.11	15.71	
		1710.7 (131979)	17.11	15.64	
	6RB (0)	1779.3 (132665)	16.08	15.25	
		1745 (132322)	16.14	14.89	
		1710.7 (131979)	16.00	14.87	
	3MHz	1RB-High (14)	1778.5 (132657)	17.30	16.24
			1745 (132322)	17.38	16.00
			1711.5 (131987)	16.97	16.11
1RB-Middle (7)		1778.5 (132657)	17.43	16.15	
		1745 (132322)	17.41	16.06	
		1711.5 (131987)	17.00	16.20	
1RB-Low (0)		1778.5 (132657)	17.36	16.05	
		1745 (132322)	17.36	16.19	
		1711.5 (131987)	16.95	15.96	
8RB-High (7)		1778.5 (132657)	16.14	15.24	
		1745 (132322)	16.14	15.50	
		1711.5 (131987)	16.02	15.07	
8RB-Middle (4)		1778.5 (132657)	16.10	15.20	
		1745 (132322)	16.18	15.44	
		1711.5 (131987)	16.06	15.22	
8RB-Low (0)		1778.5 (132657)	16.16	15.17	
		1745 (132322)	16.15	15.51	



		1711.5 (131987)	16.00	15.23
	15RB (0)	1778.5 (132657)	16.09	15.19
		1745 (132322)	16.16	15.27
		1711.5 (131987)	16.06	15.26
5MHz	1RB-High (24)	1777.5 (132647)	17.16	15.83
		1745 (132322)	16.92	15.88
		1712.5 (131997)	16.88	16.20
	1RB-Middle (12)	1777.5 (132647)	17.28	15.77
		1745 (132322)	17.21	15.90
		1712.5 (131997)	16.99	16.26
	1RB-Low (0)	1777.5 (132647)	17.26	15.72
		1745 (132322)	17.11	15.80
		1712.5 (131997)	16.79	16.04
	12RB-High (13)	1777.5 (132647)	16.13	15.16
		1745 (132322)	16.16	15.09
		1712.5 (131997)	16.07	15.11
	12RB-Middle (6)	1777.5 (132647)	16.04	15.27
		1745 (132322)	16.19	15.12
		1712.5 (131997)	16.04	15.03
	12RB-Low (0)	1777.5 (132647)	16.01	15.31
		1745 (132322)	16.08	15.10
		1712.5 (131997)	15.95	14.97
	25RB (0)	1777.5 (132647)	16.01	15.14
		1745 (132322)	16.09	15.16
		1712.5 (131997)	16.03	15.14
10MHz	1RB-High (49)	1775 (132622)	17.43	16.24
		1745 (132322)	17.27	16.24
		1715 (132022)	17.08	15.65
	1RB-Middle (24)	1775 (132622)	17.65	16.47
		1745 (132322)	17.67	16.84
		1715 (132022)	17.46	16.19
	1RB-Low (0)	1775 (132622)	17.36	15.90
		1745 (132322)	17.31	16.21
		1715 (132022)	16.90	15.38
	25RB-High (25)	1775 (132622)	16.11	15.52
		1745 (132322)	16.17	15.30
		1715 (132022)	16.18	15.11
	25RB-Middle (12)	1775 (132622)	16.16	15.44
		1745 (132322)	16.12	15.17
		1715 (132022)	16.12	15.14
25RB-Low (0)	1775 (132622)	16.15	15.22	
	1745 (132322)	16.11	15.18	

		1715 (132022)	16.00	15.19
	50RB (0)	1775 (132622)	16.12	15.19
		1745 (132322)	16.09	15.15
		1715 (132022)	16.14	15.22
15MHz	1RB-High (74)	1772.5 (132597)	16.19	16.12
		1745 (132322)	16.11	16.08
		1717.5 (132047)	16.06	16.72
	1RB-Middle (37)	1772.5 (132597)	16.40	16.39
		1745 (132322)	16.16	16.14
		1717.5 (132047)	16.10	16.95
	1RB-Low (0)	1772.5 (132597)	16.14	16.06
		1745 (132322)	16.20	15.75
		1717.5 (132047)	16.01	16.64
	36RB-High (38)	1772.5 (132597)	16.21	15.26
		1745 (132322)	16.22	15.40
		1717.5 (132047)	16.25	15.36
	36RB-Middle (19)	1772.5 (132597)	16.26	15.31
		1745 (132322)	16.21	15.31
		1717.5 (132047)	16.18	15.30
	36RB-Low (0)	1772.5 (132597)	16.14	15.27
		1745 (132322)	16.23	15.34
		1717.5 (132047)	16.08	15.03
	75RB (0)	1772.5 (132597)	16.20	15.26
		1745 (132322)	16.20	15.33
		1717.5 (132047)	16.21	15.17
20MHz	1RB-High (99)	1770 (132572)	17.18	15.91
		1745 (132322)	16.93	15.85
		1720 (132072)	16.94	15.80
	1RB-Middle (50)	1770 (132572)	17.52	16.18
		1745 (132322)	17.31	15.84
		1720 (132072)	17.31	16.33
	1RB-Low (0)	1770 (132572)	17.11	15.85
		1745 (132322)	17.12	15.89
		1720 (132072)	16.69	15.59
	50RB-High (50)	1770 (132572)	16.14	15.10
		1745 (132322)	16.22	15.27
		1720 (132072)	16.08	15.25
	50RB-Middle (25)	1770 (132572)	16.17	15.32
		1745 (132322)	16.13	15.18
		1720 (132072)	16.14	15.31
50RB-Low (0)	1770 (132572)	16.06	15.13	
	1745 (132322)	16.22	15.17	

		1720 (132072)	16.11	15.03
	100RB (0)	1770 (132572)	16.05	15.11
		1745 (132322)	16.21	15.20
		1720 (132072)	16.19	15.21

## 11.2 Wi-Fi Measurement result

The average conducted power for Wi-Fi 2.4G is as following-Normal Power:

802.11b	
Channel\data rate	1Mbps
11(2462MHz)	16.28
6(2437(MHz)	16.63
1(2412MHz)	16.94
Tune up	17.00
802.11g	
Channel\data rate	6Mbps
11(2462MHz)	14.91
6(2437(MHz)	14.71
1(2412MHz)	14.98
Tune up	15.50
802.11n-20MHz	
Channel\data rate	MCS0
11(2462MHz)	14.62
6(2437(MHz)	14.70
1(2412MHz)	15.25
Tune up	15.50

The average conducted power for Wi-Fi 5G is as following-Normal Power:

<b>802.11a(dBm)</b>	
Channel\data rate	6Mbps
36(5180 MHz)	11.62
40(5200 MHz)	11.91
44(5220 MHz)	11.88
48(5240 MHz)	11.95
52(5260 MHz)	11.81
56(5280 MHz)	11.55
60(5300 MHz)	11.25
64(5320 MHz)	11.12
100(5500 MHz)	11.36
104(5520 MHz)	11.35
108(5540 MHz)	11.37
112(5560 MHz)	11.86
116(5580 MHz)	11.91
120(5600 MHz)	12.03
124(5620 MHz)	11.87
128(5640 MHz)	11.57
132(5660 MHz)	11.54
136(5680 MHz)	11.58
140(5700 MHz)	12.10
144(5720 MHz)	12.39
149(5745 MHz)	12.41
153(5765 MHz)	12.69
157(5785 MHz)	12.55
161(5805 MHz)	12.15
165(5825 MHz)	11.92
Tune up	13.00

The average conducted power for Wi-Fi 2.4G is as following-Low Power:

<b>802.11b</b>	
Channel\data rate	1Mbps
11(2462MHz)	14.38
6(2437(MHz)	14.08
1(2412MHz)	14.59
Tune up	15.00
<b>802.11g</b>	
Channel\data rate	6Mbps
11(2462MHz)	13.77
6(2437(MHz)	13.52

1(2412MHz)	13.98
Tune up	14.50
802.11n-20MHz	
Channel\data rate	MCS0
11(2462MHz)	13.44
6(2437(MHz)	13.32
1(2412MHz)	13.71
Tune up	14.50

The average conducted power for Wi-Fi 5G is as following-Low Power:

<b>802.11a(dBm)</b>	
Channel\data rate	6Mbps
36(5180 MHz)	10.20
40(5200 MHz)	10.43
44(5220 MHz)	10.39
48(5240 MHz)	10.41
52(5260 MHz)	10.46
56(5280 MHz)	10.18
60(5300 MHz)	10.03
64(5320 MHz)	10.01
100(5500 MHz)	10.04
104(5520 MHz)	10.03
108(5540 MHz)	10.02
112(5560 MHz)	10.04
116(5580 MHz)	10.20
120(5600 MHz)	10.19
124(5620 MHz)	10.18
128(5640 MHz)	10.01
132(5660 MHz)	10.02
136(5680 MHz)	10.11
140(5700 MHz)	10.68
144(5720 MHz)	11.01
149(5745 MHz)	10.99
153(5765 MHz)	11.36
157(5785 MHz)	11.27
161(5805 MHz)	10.89
165(5825 MHz)	10.66
Tune up	12.00

## 12 Simultaneous TX SAR Considerations

### 12.1 Introduction

The following procedures adopted from “FCC SAR Considerations for Cell Phones with Multiple Transmitters” are applicable to handsets with built-in unlicensed transmitters such as 802.11 a/b/g devices which may simultaneously transmit with the licensed transmitter.

For this device, Wi-Fi can transmit simultaneous with other transmitters.

### 12.2 Transmit Antenna Separation Distances

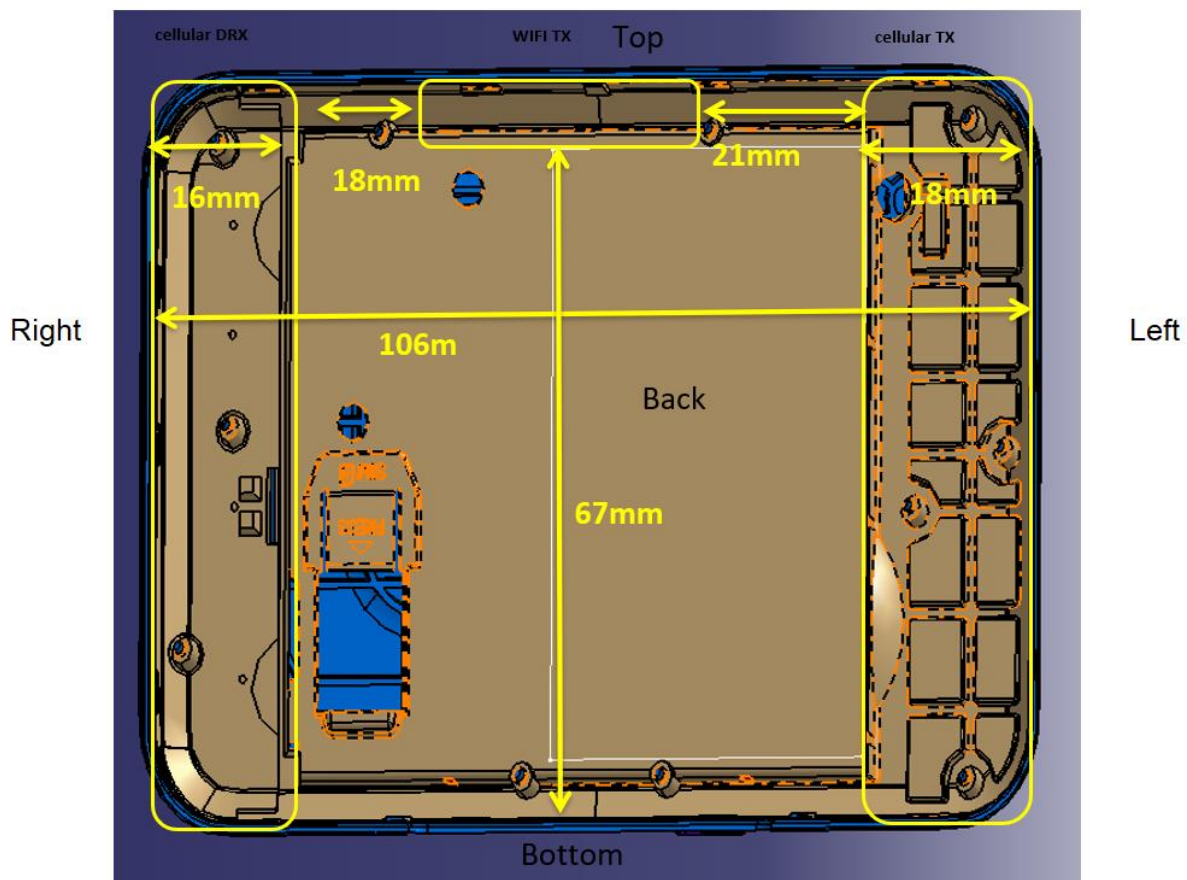

Picture 12.1 Antenna Locations

### 12.3 SAR Measurement Positions

According to the KDB941225 D06 Hot Spot SAR, the edges with less than 2.5 cm distance to the antennas need to be tested for SAR.

SAR measurement positions						
Mode	Front	Rear	Left edge	Right edge	Top edge	Bottom edge
Main Antenna	Yes	Yes	Yes	No	Yes	Yes
WiFi Antenna-ANT2	Yes	Yes	No	No	Yes	No

### 12.4 Standalone SAR Test Exclusion Considerations

Standalone 1-g body SAR evaluation by measurement or numerical simulation is not required when the corresponding SAR Exclusion Threshold condition, listed below, is satisfied.

The 1-g SAR test exclusion threshold for 100 MHz to 6 GHz at test separation distances  $\leq 50$  mm are determined by:

$[(\text{max. power of channel, including tune-up tolerance, mW}) / (\text{min. test separation distance, mm})] \cdot [\sqrt{f(\text{GHz})}] \leq 3.0$  for 1-g SAR, where

- $f(\text{GHz})$  is the RF channel transmit frequency in GHz
- Power and distance are rounded to the nearest mW and mm before calculation
- The result is rounded to one decimal place for comparison

**Table 12.1: Standalone SAR test exclusion considerations**

Band/Mode	F(GHz)	Position	SAR test exclusion threshold(mW)	RF output power		SAR test exclusion
				dBm	mW	
2.4GHz WLAN	2.45	Body	19.17	17	50.12	No
5GHz WLAN	5.2	Body	13.16	13	20	No
	5.3	Body	13.03	13	20	No
	5.6	Body	12.68	13	20	No
	5.8	Body	12.46	13	20	No

### 13 Evaluation of Simultaneous

**Table 13.1: The sum of SAR values for Main antenna + WiFi-2.4G**

	Position	Main antenna	WiFi-2.4G	Sum
<b>Highest SAR value for Body</b>	Top 5mm (LTE Band2)	0.89	0.54	<b>1.43</b>

**Table 13.2: The sum of SAR values for Main antenna + WiFi-5G**

	Position	Main antenna	WiFi-5G	Sum
<b>Highest SAR value for Body</b>	Front 5mm (LTE Band30)	0.96	0.53	<b>1.49</b>

When standalone SAR test exclusion applies to an antenna that transmits simultaneously with other antennas, the standalone SAR must be estimated according to following to determine simultaneous transmission SAR test exclusion:

(max. power of channel, including tune-up tolerance, mW)/(min. test separation distance, mm)]·[ $\sqrt{f(\text{GHz})/x}$ ] W/kg for test separation distances  $\leq 50$  mm;

where  $x = 7.5$  for 1-g SAR.

When the minimum test separation distance is  $< 5$  mm, a distance of 5 mm is applied to determine SAR test exclusion

**Conclusion:**

According to the above tables, the sum of reported SAR values is  $< 1.6$ W/kg. So the simultaneous transmission SAR with volume scans is not required.



## 14 SAR Test Result

It is determined by user manual for the distance between the EUT and the phantom bottom. It is performed for all SAR measurements with area scan based 1-g SAR estimation (Fast SAR). A zoom scan measurement is added when the estimated 1-g SAR is the highest measured SAR in each exposure configuration, wireless mode and frequency band combination or more than 1.2W/kg.

The calculated SAR is obtained by the following formula:

$$\text{Reported SAR} = \text{Measured SAR} \times 10^{(P_{\text{Target}} - P_{\text{Measured}})/10}$$

Where  $P_{\text{Target}}$  is the power of manufacturing upper limit;

$P_{\text{Measured}}$  is the measured power in chapter 11.

**Table 14.1: Duty Cycle**

Mode	Duty Cycle
LTE FDD	1:1

### 14.1 SAR results for Fast SAR

**Table 14.1-1: SAR Values (LTE Band 2-Body)**

Frequency		Test setup	Figure No./ Note	Conducted Power (dBm)	Max. tune-up Power (dBm)	Measured SAR(10g) (W/kg)	Reported SAR(10g) (W/kg)	Measured SAR(1g) (W/kg)	Reported SAR(1g) (W/kg)	Power Drift (dB)
Ch.	MHz									
Ambient Temperature: 22.9 °C		Liquid Temperature: 22.5°C								
19100	1900	1RB-Mid Front 17mm	/	22.43	23	0.357	<b>0.41</b>	0.562	<b>0.64</b>	0.1
19100	1900	1RB-Mid Rear 17mm	/	22.43	23	0.305	<b>0.35</b>	0.466	<b>0.53</b>	-0.06
19100	1900	1RB-Mid Left 19mm	/	22.43	23	0.198	<b>0.23</b>	0.313	<b>0.36</b>	-0.12
19100	1900	1RB-Mid Bottom 5mm	/	22.43	23	0.263	<b>0.30</b>	0.461	<b>0.53</b>	-0.09
19100	1900	1RB-Mid Top 5mm	/	22.43	23	0.45	<b>0.51</b>	0.783	<b>0.89</b>	0.00
18900	1880	1RB-Mid Top 5mm	/	22.39	23	0.429	<b>0.49</b>	0.746	<b>0.86</b>	0.08
18700	1860	1RB-Mid Top 5mm	/	22.25	23	0.412	<b>0.49</b>	0.722	<b>0.86</b>	0.04
19100	1900	50RB-Mid Front 17mm	/	21.41	22	0.277	<b>0.32</b>	0.436	<b>0.50</b>	-0.08
19100	1900	50RB-Mid Rear 17mm	/	21.41	22	0.248	<b>0.28</b>	0.378	<b>0.43</b>	0.02
19100	1900	50RB-Mid Left 19mm	/	21.41	22	0.154	<b>0.18</b>	0.243	<b>0.28</b>	0.01
19100	1900	50RB-Mid Bottom 5mm	/	21.41	22	0.204	<b>0.23</b>	0.357	<b>0.41</b>	0.18
19100	1900	50RB-Mid Top 5mm	/	21.41	22	0.368	<b>0.42</b>	0.641	<b>0.73</b>	-0.07
19100	1900	100RB	/	21.23	22	0.354	<b>0.42</b>	0.628	<b>0.75</b>	0.12
19100	1900	1RB-Middle Front5mm	Fig.1	18.64	19	0.479	<b>0.52</b>	0.835	<b>0.91</b>	-0.02
19100	1900	1RB-Mid Rear 5mm	/	18.64	19	0.452	<b>0.49</b>	0.774	<b>0.84</b>	0.1
19100	1900	1RB-Mid Left 5mm	/	18.64	19	0.136	<b>0.15</b>	0.259	<b>0.28</b>	0.14
18900	1880	50RB-Mid Front 5mm	/	17.41	18	0.369	<b>0.42</b>	0.644	<b>0.74</b>	-0.09

18900	1880	50RB-Mid Rear 5mm	/	17.41	18	0.342	<b>0.39</b>	0.585	<b>0.67</b>	-0.01
18900	1880	50RB-Mid Left 5mm	/	17.41	18	0.128	<b>0.15</b>	0.244	<b>0.28</b>	-0.07

Note4: The LTE mode is QPSK\_20MHz.

**Table 14.1-2: SAR Values (LTE Band 5-Body)**

Frequency		Test setup	Figure No./ Note	Conducted Power (dBm)	Max. tune-up Power (dBm)	Measured SAR(10g) (W/kg)	Reported SAR(10g) (W/kg)	Measured SAR(1g) (W/kg)	Reported SAR(1g) (W/kg)	Power Drift (dB)
Ch.	MHz									
Ambient Temperature: 22.9 °C		Liquid Temperature: 22.5 °C								
20525	836.5	1RB-Mid Front17mm	/	23.18	24	0.301	<b>0.36</b>	0.421	<b>0.51</b>	0.08
20525	836.5	1RB-Mid Rear17mm	/	23.18	24	0.382	<b>0.46</b>	0.56	<b>0.68</b>	-0.17
20525	836.5	1RB-Mid Left19mm	/	23.18	24	0.026	<b>0.03</b>	0.041	<b>0.05</b>	-0.02
20525	836.5	1RB-Mid Bottom5mm	/	23.18	24	0.279	<b>0.34</b>	0.416	<b>0.50</b>	0.05
20525	836.5	1RB-Mid Top5mm	/	23.18	24	0.281	<b>0.34</b>	0.413	<b>0.50</b>	-0.07
20525	836.5	25RB-Mid Front17mm	/	21.99	23	0.248	<b>0.31</b>	0.347	<b>0.44</b>	-0.01
20525	836.5	25RB-Mid Rear17mm	/	21.99	23	0.304	<b>0.38</b>	0.446	<b>0.56</b>	0.14
20525	836.5	25RB-Mid Left19mm	/	21.99	23	0.022	<b>0.03</b>	0.034	<b>0.04</b>	-0.16
20525	836.5	25RB-Mid Bottom5mm	/	21.99	23	0.231	<b>0.29</b>	0.344	<b>0.43</b>	-0.18
20525	836.5	25RB-Mid Top5mm	/	21.99	23	0.235	<b>0.30</b>	0.301	<b>0.38</b>	0.09
20600	844	1RB-Mid Front5mm	/	21.11	22	0.327	<b>0.40</b>	0.517	<b>0.63</b>	0.08
20600	844	1RB-Mid Rear5mm	Fig.2	21.11	22	0.456	<b>0.56</b>	0.793	<b>0.97</b>	0.04
20525	836.5	1RB-Mid Rear5mm	/	21.03	22	0.437	<b>0.55</b>	0.768	<b>0.96</b>	0.08
20450	829	1RB-Mid Rear5mm	/	20.88	22	0.417	<b>0.54</b>	0.743	<b>0.96</b>	-0.03
20600	844	1RB-Mid Left 5mm	/	21.11	22	0.099	<b>0.12</b>	0.173	<b>0.21</b>	0.08
20525	836.5	25RB-High Front5mm	/	19.93	21	0.266	<b>0.34</b>	0.421	<b>0.54</b>	-0.13
20525	836.5	25RB-High Rear5mm	/	19.93	21	0.376	<b>0.48</b>	0.653	<b>0.84</b>	0.13
20525	836.5	25RB-High Left5mm	/	19.93	21	0.081	<b>0.10</b>	0.141	<b>0.18</b>	0.18
20525	836.5	50RB Rear 5mm	/	19.81	21	0.359	<b>0.47</b>	0.635	<b>0.84</b>	0.09

Note4: The LTE mode is QPSK\_10MHz.

**Table 14.1-3: SAR Values (LTE Band 12-Body)**

Frequency		Test setup	Figure No./ Note	Conducted Power (dBm)	Max. tune-up Power (dBm)	Measured SAR(10g) (W/kg)	Reported SAR(10g) (W/kg)	Measured SAR(1g) (W/kg)	Reported SAR(1g) (W/kg)	Power Drift (dB)
Ch.	MHz									
Ambient Temperature: 22.9 °C		Liquid Temperature: 22.5 °C								
23060	704	1RB-Mid Front 17mm	/	22.43	23.5	0.197	<b>0.25</b>	0.277	<b>0.35</b>	-0.14
23060	704	1RB-Mid Rear 17mm	/	22.43	23.5	0.23	<b>0.29</b>	0.323	<b>0.41</b>	0.15
23060	704	1RB-Mid Left 19mm	/	22.43	23.5	<0.01	<0.01	<0.01	<0.01	/
23060	704	1RB-Mid Bottom 5mm	/	22.43	23.5	0.246	<b>0.31</b>	0.364	<b>0.47</b>	0.05
23060	704	1RB-Mid Top 5mm	/	22.43	23.5	0.172	<b>0.22</b>	0.261	<b>0.33</b>	-0.07
23060	704	25RB-High Front 17mm	/	20.95	22.5	0.146	<b>0.21</b>	0.206	<b>0.29</b>	-0.17
23060	704	25RB-High Rear 17mm	/	20.95	22.5	0.182	<b>0.26</b>	0.253	<b>0.36</b>	0.18
23060	704	25RB-High Left 19mm	/	20.95	22.5	<0.01	<0.01	<0.01	<0.01	/
23060	704	25RB-High Bottom 5mm	/	20.95	22.5	0.191	<b>0.27</b>	0.284	<b>0.41</b>	-0.04
23060	704	25RB-High Top 5mm	/	20.95	22.5	0.128	<b>0.18</b>	0.194	<b>0.28</b>	-0.06
23060	704	1RB-Mid Front 5mm	Fig.3	20.96	22	0.402	<b>0.51</b>	0.571	<b>0.73</b>	0.04
23060	704	1RB-Mid Rear 5mm	/	20.96	22	0.389	<b>0.49</b>	0.531	<b>0.67</b>	0.08
23060	704	1RB-Mid Left 5mm	/	20.96	22	0.075	<b>0.10</b>	0.128	<b>0.16</b>	-0.15
23095	707.5	25RB-High Front 5mm	/	19.94	21	0.317	<b>0.40</b>	0.451	<b>0.58</b>	0.17
23095	707.5	25RB-High Rear 5mm	/	19.94	21	0.314	<b>0.40</b>	0.426	<b>0.54</b>	0.01
23095	707.5	25RB-High Left 5mm	/	19.94	21	0.059	<b>0.08</b>	0.103	<b>0.13</b>	0.06

Note4: The LTE mode is QPSK\_10MHz.

**Table 14.1-4: SAR Values (LTE Band 14-Body)**

Frequency		Test setup	Figure No./ Note	Conducted Power (dBm)	Max. tune-up Power (dBm)	Measured SAR(10g) (W/kg)	Reported SAR(10g) (W/kg)	Measured SAR(1g) (W/kg)	Reported SAR(1g) (W/kg)	Power Drift (dB)
Ch.	MHz									
		Ambient Temperature: 22.9 °C		Liquid Temperature: 22.5°C						
23330	793	1RB-Mid Front 17mm	/	23.35	23.5	0.279	<b>0.29</b>	0.38	<b>0.39</b>	0.13
23330	793	1RB-Mid Rear 17mm	/	23.35	23.5	0.354	<b>0.37</b>	0.485	<b>0.50</b>	0.13
23330	793	1RB-Mid Left 19mm	/	23.35	23.5	0.024	<b>0.02</b>	0.035	<b>0.04</b>	-0.14
23330	793	1RB-Mid Bottom 5mm	/	23.35	23.5	0.288	<b>0.30</b>	0.42	<b>0.43</b>	-0.04
23330	793	1RB-Mid Top 5mm	/	23.35	23.5	0.331	<b>0.34</b>	0.493	<b>0.51</b>	-0.04
23330	793	25RB-Low Front 17mm	/	22.19	22.5	0.233	<b>0.25</b>	0.318	<b>0.34</b>	0.06
23330	793	25RB-Low Rear 17mm	/	22.19	22.5	0.265	<b>0.28</b>	0.364	<b>0.39</b>	-0.15
23330	793	25RB-Low Left 19mm	/	22.19	22.5	0.02	<b>0.02</b>	0.028	<b>0.03</b>	0.16
23330	793	25RB-Low Bottom 5mm	/	22.19	22.5	0.246	<b>0.26</b>	0.359	<b>0.39</b>	-0.11
23330	793	25RB-Low Top 5mm	/	22.19	22.5	0.267	<b>0.29</b>	0.397	<b>0.43</b>	0.06
23330	793	1RB-Mid Front 5mm	/	20.33	21.5	0.359	<b>0.47</b>	0.473	<b>0.62</b>	0.07
23330	793	1RB-Mid Rear 5mm	Fig.4	20.33	21.5	0.407	<b>0.53</b>	0.547	<b>0.72</b>	-0.03
23330	793	1RB-Mid Left 5mm	/	20.33	21.5	0.069	<b>0.09</b>	0.111	<b>0.15</b>	0.07
23330	793	25RB-High Front 5mm	/	19.04	20.5	0.289	<b>0.40</b>	0.381	<b>0.53</b>	-0.16
23330	793	25RB-High Rear 5mm	/	19.04	20.5	0.311	<b>0.44</b>	0.419	<b>0.59</b>	0.16
23330	793	25RB-High Left 5mm	/	19.04	20.5	0.052	<b>0.07</b>	0.083	<b>0.12</b>	0.05

Note4: The LTE mode is QPSK\_10MHz.

**Table 14.1-5: SAR Values (LTE Band 30-Body)**

Frequency		Test setup	Figure No./ Note	Conducted Power (dBm)	Max. tune-up Power (dBm)	Measured SAR(10g) (W/kg)	Reported SAR(10g) (W/kg)	Measured SAR(1g) (W/kg)	Reported SAR(1g) (W/kg)	Power Drift (dB)
Ch.	MHz									
		Ambient Temperature: 22.9 °C		Liquid Temperature: 22.5°C						
27710	2310	1RB-Mid Front 17mm	/	21.57	22.5	0.216	<b>0.27</b>	0.384	<b>0.48</b>	-0.17
27710	2310	1RB-Mid Rear 17mm	/	21.57	22.5	0.192	<b>0.24</b>	0.335	<b>0.41</b>	0.17
27710	2310	1RB-Mid Left 19mm	/	21.57	22.5	0.172	<b>0.21</b>	0.293	<b>0.36</b>	-0.07
27710	2310	1RB-Mid Bottom 5mm	/	21.57	22.5	0.136	<b>0.17</b>	0.243	<b>0.30</b>	-0.09
27710	2310	1RB-Mid Top 5mm	/	21.57	22.5	0.241	<b>0.30</b>	0.431	<b>0.53</b>	0.09
27710	2310	25RB-Mid Front 17mm	/	20.36	21.5	0.172	<b>0.22</b>	0.307	<b>0.40</b>	-0.02
27710	2310	25RB-Mid Rear 17mm	/	20.36	21.5	0.151	<b>0.20</b>	0.264	<b>0.34</b>	-0.18
27710	2310	25RB-Mid Left 19mm	/	20.36	21.5	0.139	<b>0.18</b>	0.236	<b>0.31</b>	-0.17
27710	2310	25RB-Mid Bottom 5mm	/	20.36	21.5	0.11	<b>0.14</b>	0.194	<b>0.25</b>	0.14
27710	2310	25RB-Mid Top 5mm	/	20.36	21.5	0.183	<b>0.24</b>	0.326	<b>0.42</b>	-0.02

27710	2310	1RB-Mid Front 5mm	Fig.5	17.33	18.5	0.357	<b>0.47</b>	0.736	<b>0.96</b>	0.06
27710	2310	1RB-Mid Rear 5mm	/	17.33	18.5	0.298	<b>0.39</b>	0.573	<b>0.75</b>	0.00
27710	2310	1RB-Mid Left 5mm	/	17.33	18.5	0.22	<b>0.29</b>	0.444	<b>0.58</b>	-0.16
27710	2310	25RB-High Front 5mm	/	16.11	17.5	0.253	<b>0.35</b>	0.521	<b>0.72</b>	0.17
27710	2310	25RB-High Rear 5mm	/	16.11	17.5	0.209	<b>0.29</b>	0.401	<b>0.55</b>	0.12
27710	2310	25RB-High Left 5mm	/	16.11	17.5	0.161	<b>0.22</b>	0.325	<b>0.45</b>	-0.16
27710	2310	50RB Front 5mm	/	16.06	17.5	0.237	<b>0.33</b>	0.512	<b>0.71</b>	0.07
27710	2310	1RB-Mid Front 5mm USB	/	17.33	18.5	0.352	<b>0.46</b>	0.716	<b>0.94</b>	-0.13

Note4: The LTE mode is QPSK\_10MHz.

**Table 14.1-6: SAR Values (LTE Band66 –Body)**

Frequency		Mode	Figure No.	Ambient Temperature: 22.9 °C		Liquid Temperature: 22.5°C		Measured SAR(1g) (W/kg)	Reported SAR(1g) (W/kg)	Power Drift (dB)
Ch.	MHz			Conducted Power (dBm)	Max. tune-up Power (dBm)	Measured SAR(10g) (W/kg)	Reported SAR(10g) (W/kg)			
132572	1770	1RB-Mid Front 17mm	/	21.47	23	0.246	<b>0.35</b>	0.386	<b>0.55</b>	-0.15
132572	1770	1RB-Mid Rear 17mm	/	21.47	23	0.189	<b>0.27</b>	0.306	<b>0.44</b>	0.09
132572	1770	1RB-Mid Left 19mm	/	21.47	23	0.123	<b>0.17</b>	0.196	<b>0.28</b>	0
132572	1770	1RB-Mid Bottom 5mm	/	21.47	23	0.205	<b>0.29</b>	0.356	<b>0.51</b>	0.03
132572	1770	1RB-Mid Top 5mm	/	21.47	23	0.133	<b>0.19</b>	0.231	<b>0.33</b>	0.18
132322	1745	50RB-High Front 17mm	/	20.47	22	0.179	<b>0.25</b>	0.28	<b>0.40</b>	0.05
132322	1745	50RB-High Rear 17mm	/	20.47	22	0.153	<b>0.22</b>	0.233	<b>0.33</b>	-0.12
132322	1745	50RB-High Left 19mm	/	20.47	22	0.105	<b>0.15</b>	0.168	<b>0.24</b>	-0.08
132322	1745	50RB-High Bottom 5mm	/	20.47	22	0.185	<b>0.26</b>	0.319	<b>0.45</b>	0.08
132322	1745	50RB-High Top 5mm	/	20.47	22	0.1	<b>0.14</b>	0.169	<b>0.24</b>	-0.01
132572	1770	1RB-Mid Front 5mm	Fig.6	17.52	18	0.404	<b>0.45</b>	0.676	<b>0.75</b>	0.03
132572	1770	1RB-Mid Rear 5mm	/	17.52	18	0.272	<b>0.30</b>	0.497	<b>0.56</b>	0.12
132572	1770	1RB-Mid Left 5mm	/	17.52	18	0.167	<b>0.19</b>	0.322	<b>0.36</b>	-0.05
132322	1745	50RB-High Front 5mm	/	16.22	17	0.325	<b>0.39</b>	0.556	<b>0.67</b>	-0.15
132322	1745	50RB-High Rear 5mm	/	16.22	17	0.262	<b>0.31</b>	0.488	<b>0.58</b>	0.03

Note: The distance between the EUT and the phantom bottom is 10mm. The LTE mode is QPSK\_20MHz.

### 14.2 SAR results for Standard procedure

There is zoom scan measurement to be added for the highest measured SAR in each exposure configuration/band.

**Table 14.2-1: SAR Values (LTE Band 2-Body)**

Frequency		Test setup	Figure No./ Note	Conducted Power (dBm)	Max. tune-up Power (dBm)	Measured SAR(10g) (W/kg)	Reported SAR(10g) (W/kg)	Measured SAR(1g) (W/kg)	Reported SAR(1g) (W/kg)	Power Drift (dB)
Ch.	MHz									
		Ambient Temperature: 22.9 °C		Liquid Temperature: 22.5°C						
19100	1900	1RB-Middle Front5mm	Fig.1	18.64	19	0.479	<b>0.52</b>	0.835	<b>0.91</b>	-0.02

Note4: The LTE mode is QPSK\_20MHz.

**Table 14.2-2: SAR Values (LTE Band 5-Body)**

Frequency		Test setup	Figure No./ Note	Conducted Power (dBm)	Max. tune-up Power (dBm)	Measured SAR(10g) (W/kg)	Reported SAR(10g) (W/kg)	Measured SAR(1g) (W/kg)	Reported SAR(1g) (W/kg)	Power Drift (dB)
Ch.	MHz									
		Ambient Temperature: 22.9 °C		Liquid Temperature: 22.5°C						
20600	844	1RB-Mid Rear5mm	Fig.2	21.11	22	0.456	<b>0.56</b>	0.793	<b>0.97</b>	0.04

Note4: The LTE mode is QPSK\_10MHz.

**Table 14.2-3: SAR Values (LTE Band 12-Body)**

Frequency		Test setup	Figure No./ Note	Conducted Power (dBm)	Max. tune-up Power (dBm)	Measured SAR(10g) (W/kg)	Reported SAR(10g) (W/kg)	Measured SAR(1g) (W/kg)	Reported SAR(1g) (W/kg)	Power Drift (dB)
Ch.	MHz									
		Ambient Temperature: 22.9 °C		Liquid Temperature: 22.5°C						
23060	704	1RB-Mid Front 5mm	Fig.3	20.96	22	0.402	<b>0.51</b>	0.571	<b>0.73</b>	0.04

Note4: The LTE mode is QPSK\_10MHz.

**Table 14.2-4: SAR Values (LTE Band 14-Body)**

Frequency		Test setup	Figure No./ Note	Conducted Power (dBm)	Max. tune-up Power (dBm)	Measured SAR(10g) (W/kg)	Reported SAR(10g) (W/kg)	Measured SAR(1g) (W/kg)	Reported SAR(1g) (W/kg)	Power Drift (dB)
Ch.	MHz									
23330	793	1RB-Mid Rear 5mm	Fig.4	20.33	21.5	0.407	<b>0.53</b>	0.547	<b>0.72</b>	-0.03

Note4: The LTE mode is QPSK\_10MHz.

**Table 14.2-5: SAR Values (LTE Band 30-Body)**

Frequency		Test setup	Figure No./ Note	Conducted Power (dBm)	Max. tune-up Power (dBm)	Measured SAR(10g) (W/kg)	Reported SAR(10g) (W/kg)	Measured SAR(1g) (W/kg)	Reported SAR(1g) (W/kg)	Power Drift (dB)
Ch.	MHz									
27710	2310	1RB-Mid Front 5mm	Fig.5	17.33	18.5	0.357	<b>0.47</b>	0.736	<b>0.96</b>	0.06

Note4: The LTE mode is QPSK\_10MHz.

**Table 14.2-6: SAR Values (LTE Band66 –Body)**

Frequency		Mode	Figure No.	Conducted Power (dBm)	Max. tune-up Power (dBm)	Measured SAR(10g) (W/kg)	Reported SAR(10g) (W/kg)	Measured SAR(1g) (W/kg)	Reported SAR(1g) (W/kg)	Power Drift (dB)
Ch.	MHz									
132572	1770	1RB-Mid Front 5mm	Fig.6	17.52	18	0.404	<b>0.45</b>	0.676	<b>0.75</b>	0.03

Note: The distance between the EUT and the phantom bottom is 10mm. The LTE mode is QPSK\_20MHz.

### 14.3 WLAN Evaluation for 2.4G

According to the KDB248227 D01, SAR is measured for 2.4GHz 802.11b DSSS using the initial test position procedure.

#### Body Evaluation

**Table 14.3-1: SAR Values (WLAN - Body)– 802.11b (Fast SAR)**

Frequency		Test Position	Figure No./ Note	Conducted Power (dBm)	Max. tune-up Power (dBm)	Measured SAR(10g) (W/kg)	Reported SAR(10g) (W/kg)	Measured SAR(1g) (W/kg)	Reported SAR(1g)(W/kg)	Power Drift (dB)
Ch.	MHz									
		Ambient Temperature: 22.9 °C		Liquid Temperature: 22.5 °C						
1	2412	Front 17mm 14dB	/	16.94	17	0.066	<b>0.07</b>	0.125	<b>0.13</b>	-0.05
1	2412	Rear 17mm 14dB	/	16.94	17	0.027	<b>0.03</b>	0.046	<b>0.05</b>	-0.11
1	2412	Top 5mm 14dB	/	16.94	17	0.245	<b>0.25</b>	0.538	<b>0.55</b>	-0.07
1	2412	Front 5mm 12dB	/	14.59	15	0.188	<b>0.21</b>	0.435	<b>0.48</b>	0.16
1	2412	Rear 5mm 12dB	/	14.59	15	0.062	<b>0.07</b>	0.128	<b>0.14</b>	-0.13

As shown above table, the initial test position for body is "Rear 17mm". So the body SAR of WLAN is presented as below:

**Table 14.3-2: SAR Values (WLAN - Body)– 802.11b (Full SAR)**

Frequency		Test Position	Figure No./ Note	Conducted Power (dBm)	Max. tune-up Power (dBm)	Measured SAR(10g) (W/kg)	Reported SAR(10g) (W/kg)	Measured SAR(1g) (W/kg)	Reported SAR(1g)(W/kg)	Power Drift (dB)
Ch.	MHz									
		Ambient Temperature: 22.9 °C		Liquid Temperature: 22.5 °C						
1	2412	Top 5 mm 14dB	Fig.7	16.94	17	0.238	0.24	0.530	<b>0.54</b>	-0.07
1	2412	Front 5mm12dB	/	14.59	15	0.180	0.20	0.412	<b>0.45</b>	0.16

Note1: When the reported SAR of the initial test position is > 0.4 W/kg, SAR is repeated for the 802.11 transmission mode configuration tested in the initial test position using subsequent highest estimated 1-g SAR conditions determined by area scans, on the highest maximum output power channel, until the reported SAR is ≤ 0.8 W/kg.

Note2: For all positions/configurations tested using the initial test position and subsequent test positions, when the reported SAR is > 0.8 W/kg, SAR is measured for these test positions/configurations on the subsequent next highest measured output power channel until the reported SAR is ≤ 1.2 W/kg or all required channels are tested.



According to the KDB248227 D01, The reported SAR must be scaled to 100% transmission duty factor to determine compliance at the maximum tune-up tolerance limit. The scaled reported SAR is presented as below.

**Table 14.3-3: SAR Values (WLAN - Body) – 802.11b (Scaled Reported SAR)**

Frequency		Test Position	Actual duty factor	maximum duty factor	Reported SAR (1g)(W/kg)	Scaled reported SAR (1g)(W/kg)
Ch.	MHz					
1	2412	Top 5 mm 14dB	98.92%	100%	<b>0.54</b>	<b>0.54</b>

SAR is not required for OFDM because the 802.11b adjusted SAR  $\leq 1.2$  W/kg.

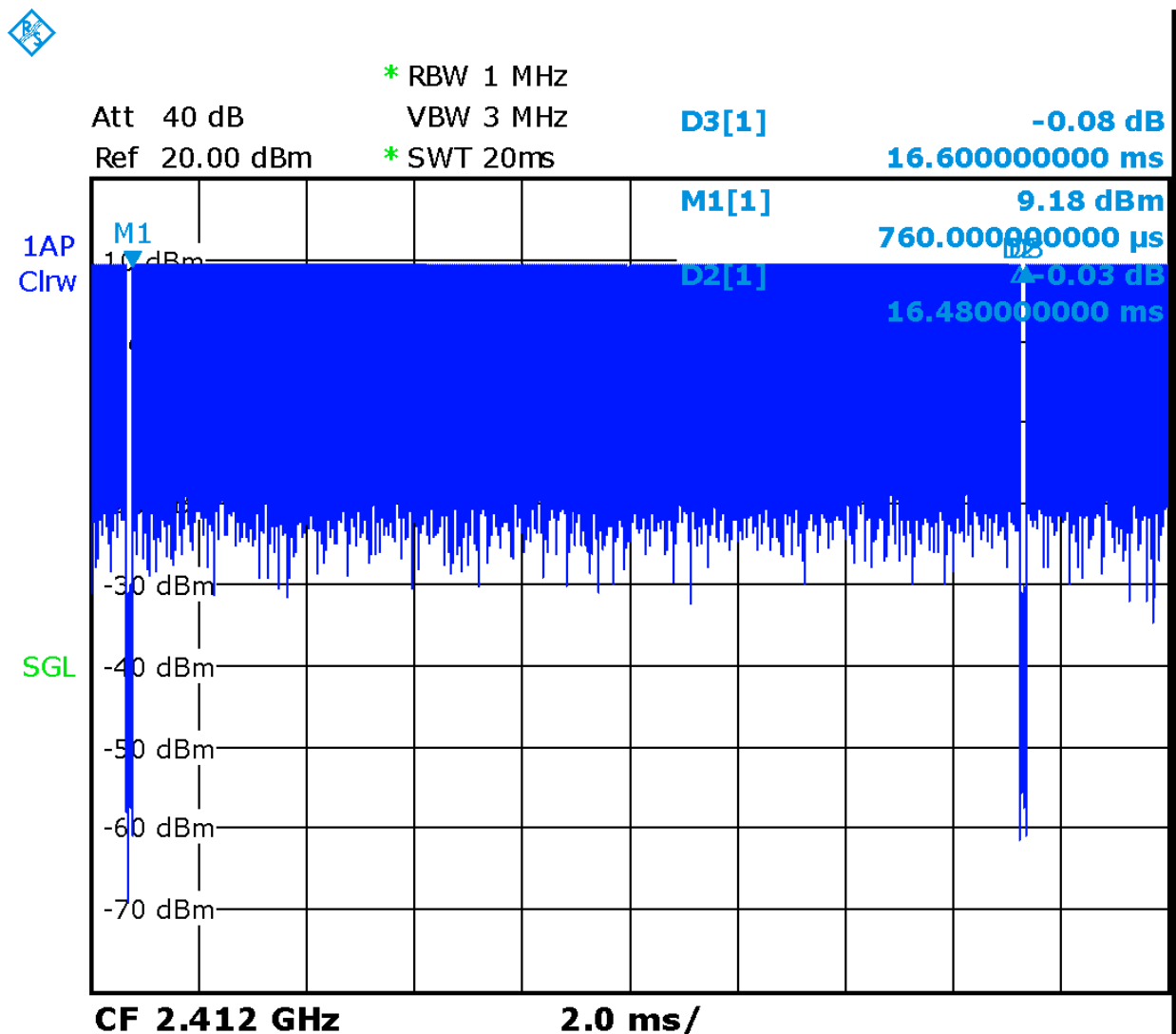

Picture 14.2 Duty factor plot

### 14.4 WLAN Evaluation For 5G

**Table 14.4-1: Maximum output power specified of WLAN antenna – Body-Normal Power**

802.11 mode	a	g	n		ac			
Ch. BW(MHz)	20	20	20	40	20	40	80	160
U-NII-1	20		18	18	16	16	16	
U-NII-2A	20		18	18	16	16	16	
U-NII-2C	20		18	18	16	16	16	
U-NII-3	20		18	18	16	16	16	
§ 15.247 (5.8 GHz)								

- The maximum output power specified for production units is the same for all channels, modulations and data rates in each channel bandwidth configuration of the 802.11a/g/n/ac modes.
- The blue highlighted cells represent highest output configurations in each standalone or aggregated frequency band, with tune-up tolerance included.

**Table 14.4-2: Maximum output power specified of WLAN antenna – Body-Low Power**

802.11 mode	a	g	n		ac			
Ch. BW(MHz)	20	20	20	40	20	40	80	160
U-NII-1	16		14	14	13	13	13	
U-NII-2A	16		14	14	13	13	13	
U-NII-2C	16		14	14	13	13	13	
U-NII-3	16		14	14	13	13	13	
§ 15.247 (5.8 GHz)								

- The maximum output power specified for production units is the same for all channels, modulations and data rates in each channel bandwidth configuration of the 802.11a/g/n/ac modes.
- The blue highlighted cells represent highest output configurations in each standalone or aggregated frequency band, with tune-up tolerance included.

**Table 14.4-3: Maximum output power measured of WLAN antenna, for the applicable OFDM configurations according to the default power measurement procedures for selection initial test configurations –Body-Normal Power**

802.11 mode	a	n		ac		
BW(MHz)	20	20	40	20	40	80
U-NII-1	36/40/44/48 15/16/15/16	36/40/44/48 Lower power	38/46 Lower power	36/40/44/48 Lower power	38/46 Lower power	42 Lower power
U-NII-2A	52/56/60/64 15/14/13/13	52/56/60/64 Lower power	54/62 Lower power	52/56/60/64 Lower power	54/62 Lower power	58 Lower power
U-NII-2C	100/104/108/112 116/120/124/128/ 132/136/140/144 14/14/14/15	100/104/108/112 116/120/124/128 /132/136/140/14 4	102/110/118/ 126/134/142 Lower power	100/104/108/11 2 116/132/136/14 0	102/110/134 Lower power	106 Lower power

	16/16/15/14 14/14/16/17	Lower power		Lower power		
<b>U-NII-3</b>	149/153/157/161/ 165 17/19/18/16/16	149/153/157/161 /165 Lower power	151/159 Lower power	149/153/157/16 1/165 Lower power	151/159 Lower power	155 Lower power
<ul style="list-style-type: none"> <li>● The <b>bold numbers</b> is the maximum output measured power (mW).</li> <li>● Channels with measured maximum power within 0.25dB are considered to have the same measured output. Channels selected for initial test configuration are <b>highlighted in yellow</b>.</li> </ul>						

**Table 14.4-4: Maximum output power measured of WLAN antenna, for the applicable OFDM configurations according to the default power measurement procedures for selection initial test configurations**

**-Body-Low Power**

802.11 mode	a	n		ac		
	20	20	40	20	40	80
<b>U-NII-1</b>	36/40/44/48 10/11/11/11	36/40/44/48 Lower power	38/46 Lower power	36/40/44/48 Lower power	38/46 Lower power	42 Lower power
<b>U-NII-2A</b>	52/56/60/64 11/10/10/10	52/56/60/64 Lower power	54/62 Lower power	52/56/60/64 Lower power	54/62 Lower power	58 Lower power
<b>U-NII-2C</b>	100/104/108/112 116/120/124/128/ 132/136/140/144 10/10/10/10/10/10 /10/10/10/10/12/1 3	100/104/108/112 116/120/124/128 /132/136/140/14 4 Lower power	102/110/118/ 126/134/142 Lower power	100/104/108/11 2 116/132/136/14 0 Lower power	102/110/134 Lower power	106 Lower power
<b>U-NII-3</b>	149/153/157/161/ 165 13/14/13/12/12	149/153/157/161 /165 Lower power	151/159 Lower power	149/153/157/16 1/165 Lower power	151/159 Lower power	155 Lower power
<ul style="list-style-type: none"> <li>● The <b>bold numbers</b> is the maximum output measured power (mW).</li> <li>● Channels with measured maximum power within 0.25dB are considered to have the same measured output. Channels selected for initial test configuration are <b>highlighted in yellow</b>.</li> </ul>						

**Table 14.4-5: Reported SAR of initial test configuration for Body  
-WiFi antenna-Normal Power**

802.11 mode	a	n		ac		
		20	40	20	40	80
BW(MHz)	20	20	40	20	40	80
U-NII-1	36/40/44/48	36/40/44/48	38/46	36/40/44/48	38/46	42
U-NII-2A	52/56/60/64 0.39	52/56/60/64	54/62	52/56/60/64	54/62	58
U-NII-2C	100/104/108/112/116/ 120/124/128/132/136/ 140/144 0.37	100/104/108/112/116/120 /124/128/132/136/140/14 4	102/110/118/ 126/134/142	100/104/108/112 116/132/136/140	102/110 /134	106
U-NII-3	149/153/157/161/165 0.15	149/153/157/161/165	151/159	149/153/157/161 /165	151/159	155

Initial test configuration SAR for U-NII-2A band is > 0.8 W/kg, SAR is required for next highest output channel in initial test configuration. The next highest output channel SAR is ≤ 1.2 W/kg, SAR is not required for subsequent next highest output channel. Similar circumstances apply to U-NII-1, U-NII-2C band and U-NII-3 band. The green highlighted channels are next highest measured output channel in the initial test configuration. Highest measured output power channel tested initially are in yellow highlight.

**Table 14.4-6: Reported SAR of initial test configuration for Body  
-WiFi antenna-Low Power**

802.11 mode	a	n		ac		
		20	40	20	40	80
BW(MHz)	20	20	40	20	40	80
U-NII-1	36/40/44/48	36/40/44/48	38/46	36/40/44/48	38/46	42
U-NII-2A	52/56/60/64 0.32	52/56/60/64	54/62	52/56/60/64	54/62	58
U-NII-2C	100/104/108/112/116/ 120/124/128/132/136/ 140/144 0.53	100/104/108/112/116/120 /124/128/132/136/140/14 4	102/110/118/ 126/134/142	100/104/108/112 116/132/136/140	102/110 /134	106
U-NII-3	149/153/157/161/165 0.47	149/153/157/161/165	151/159	149/153/157/161 /165	151/159	155

Initial test configuration SAR for U-NII-2A band is > 0.8 W/kg, SAR is required for next highest output channel in initial test configuration. The next highest output channel SAR is ≤ 1.2 W/kg, SAR is not required for subsequent next highest output channel. Similar circumstances apply to U-NII-1, U-NII-2C band and U-NII-3 band. The green highlighted channels are next highest measured output channel in the initial test configuration. Highest measured output power channel tested initially are in yellow highlight.

**Table 14.4-7: SAR Values (WLAN 5G – Body)**

Frequency		Test Position	Figure No.	Conducted Power (dBm)	Max. tune-up Power (dBm)	Measured SAR(10g) (W/kg)	Reported SAR(10g)(W/kg)	Measured SAR(1g) (W/kg)	Reported SAR(1g) (W/kg)	Power Drift (dB)
Ch.	MHz									
52	5260	11a-6M Front 17mm	/	11.81	13	0.035	<b>0.05</b>	0.095	<b>0.12</b>	-0.17
52	5260	11a-6M Rear 17mm	/	11.81	13	0.01	<b>0.01</b>	0.052	<b>0.07</b>	0.04
52	5260	11a-6M Top 5mm	/	11.81	13	0.081	<b>0.11</b>	0.289	<b>0.38</b>	-0.03
52	5260	11a-6M Front 5mm	/	10.46	12	0.073	<b>0.10</b>	0.223	<b>0.32</b>	0.09
52	5260	11a-6M Rear 5mm	/	10.46	12	0.028	<b>0.04</b>	0.074	<b>0.11</b>	-0.1
144	5720	11a-6M Front 17mm	/	12.39	13	0.057	<b>0.07</b>	0.176	<b>0.20</b>	0.01
144	5720	11a-6M Rear 17mm	/	12.39	13	0.01	<b>0.01</b>	0.062	<b>0.07</b>	0.05
144	5720	11a-6M Top 5mm	/	12.39	13	0.09	<b>0.10</b>	0.317	<b>0.36</b>	-0.14
144	5720	11a-6M Front 5mm	Fig.8	11.01	12	0.118	<b>0.15</b>	0.416	<b>0.52</b>	-0.03
144	5720	11a-6M Rear 5mm	/	11.01	12	0.011	<b>0.01</b>	0.057	<b>0.07</b>	0.15
153	5765	11a-6M Front 17mm	/	12.69	13	0.049	<b>0.05</b>	0.141	<b>0.15</b>	0.08
153	5765	11a-6M Rear 17mm	/	12.69	13	0.007	<b>0.01</b>	0.038	<b>0.04</b>	0.09
153	5765	11a-6M Top 5mm	/	12.69	13	0.081	<b>0.09</b>	0.297	<b>0.32</b>	0.14
153	5765	11a-6M Front 5mm	/	11.36	12	0.111	<b>0.13</b>	0.402	<b>0.47</b>	0.05
153	5765	11a-6M Rear 5mm	/	11.36	12	0.01	<b>0.01</b>	0.049	<b>0.06</b>	-0.17

According to the KDB248227 D01, The reported SAR must be scaled to 100% transmission duty factor to determine compliance at the maximum tune-up tolerance limit. The scaled reported SAR is presented as below.

**Table 14.4-8 SAR Values (WLAN 5G – Body) (Scaled Reported SAR)**

Frequency		Test Position	D (mm)	Actual duty factor	maximum duty factor	Reported SAR (1g) (W/kg)	Scaled reported SAR (1g) (W/kg)
Ch.	MHz						
144	5720	Front	5	98.89%	100%	<b>0.52</b>	<b>0.53</b>

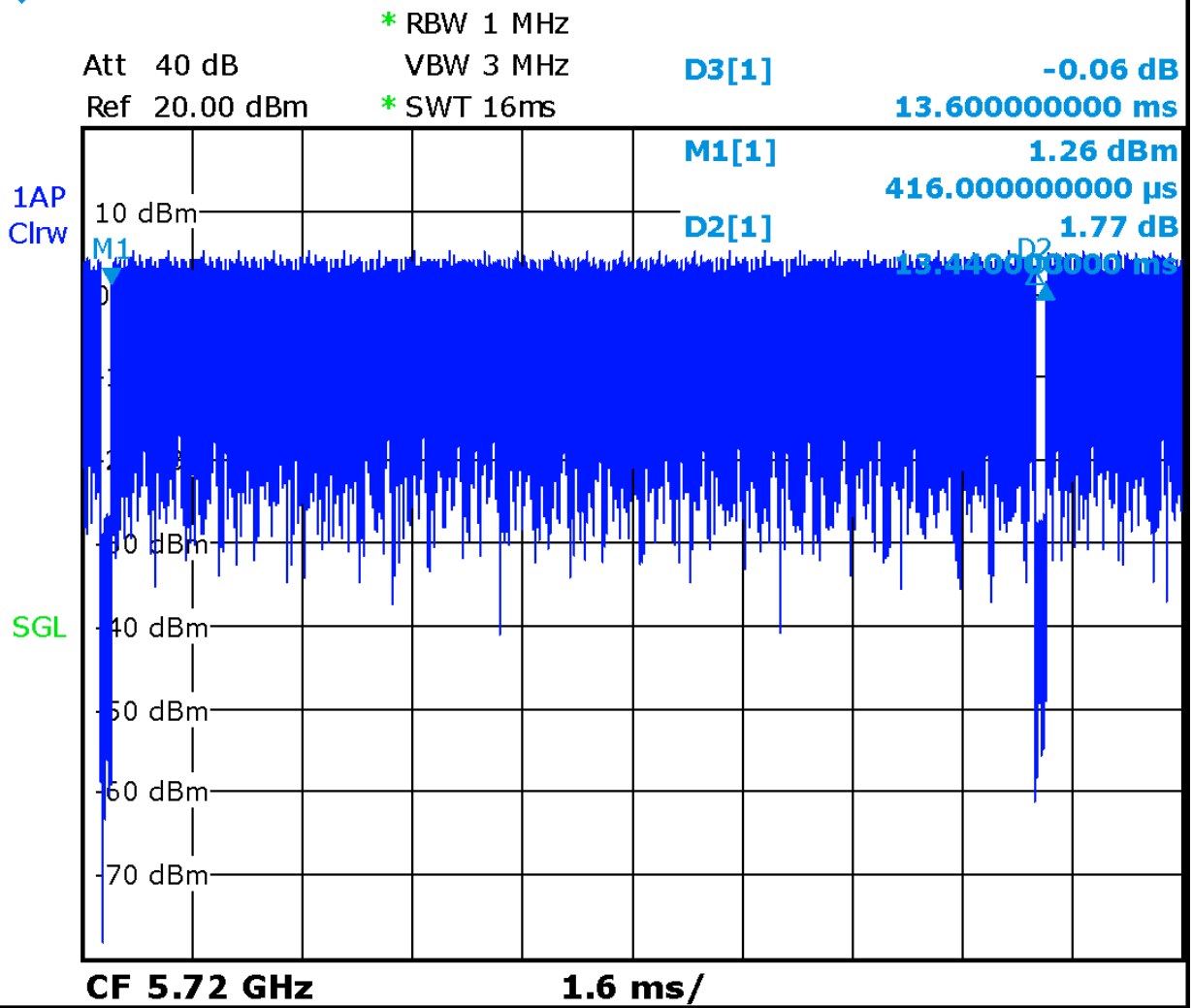

Picture 14.4-2 The plot of duty factor for Body

## 15 SAR Measurement Variability

SAR measurement variability must be assessed for each frequency band, which is determined by the SAR probe calibration point and tissue-equivalent medium used for the device measurements. When both head and body tissue-equivalent media are required for SAR measurements in a frequency band, the variability measurement procedures should be applied to the tissue medium with the highest measured SAR, using the highest measured SAR configuration for that tissue-equivalent medium.

The following procedures are applied to determine if repeated measurements are required.

- 1) Repeated measurement is not required when the original highest measured SAR is  $< 0.80$  W/kg; steps 2) through 4) do not apply.
- 2) When the original highest measured SAR is  $\geq 0.80$  W/kg, repeat that measurement once.
- 3) Perform a second repeated measurement only if the ratio of largest to smallest SAR for the original and first repeated measurements is  $> 1.20$  or when the original or repeated measurement is  $\geq 1.45$  W/kg (~ 10% from the 1-g SAR limit).
- 4) Perform a third repeated measurement only if the original, first or second repeated measurement is  $\geq 1.5$  W/kg and the ratio of largest to smallest SAR for the original, first and second repeated measurements is  $> 1.20$

**Table 15.1: SAR Measurement Variability for Body LTE Band2(1g)**

Frequency		Test Position	Spacing (mm)	Original SAR (W/kg)	First Repeated SAR (W/kg)	The Ratio	Second Repeated SAR (W/kg)
Ch.	MHz						
1900	19100	Front	5	0.835	0.827	1.01	/

## 16 Measurement Uncertainty

### 16.1 Measurement Uncertainty for Normal SAR Tests (300MHz~3GHz)

No.	Error Description	Type	Uncertainty value	Probably Distribution	Div.	(Ci) 1g	(Ci) 10g	Std. Unc. (1g)	Std. Unc. (10g)	Degree of freedom
<b>Measurement system</b>										
1	Probe calibration	B	6.0	N	1	1	1	6.0	6.0	$\infty$
2	Isotropy	B	4.7	R	$\sqrt{3}$	0.7	0.7	1.9	1.9	$\infty$
3	Boundary effect	B	1.0	R	$\sqrt{3}$	1	1	0.6	0.6	$\infty$
4	Linearity	B	4.7	R	$\sqrt{3}$	1	1	2.7	2.7	$\infty$
5	Detection limit	B	1.0	N	1	1	1	0.6	0.6	$\infty$
6	Readout electronics	B	0.3	R	$\sqrt{3}$	1	1	0.3	0.3	$\infty$
7	Response time	B	0.8	R	$\sqrt{3}$	1	1	0.5	0.5	$\infty$
8	Integration time	B	2.6	R	$\sqrt{3}$	1	1	1.5	1.5	$\infty$
9	RF ambient conditions-noise	B	0	R	$\sqrt{3}$	1	1	0	0	$\infty$
10	RF ambient conditions-reflection	B	0	R	$\sqrt{3}$	1	1	0	0	$\infty$
11	Probe positioned mech. restrictions	B	0.4	R	$\sqrt{3}$	1	1	0.2	0.2	$\infty$
12	Probe positioning with respect to phantom shell	B	2.9	R	$\sqrt{3}$	1	1	1.7	1.7	$\infty$
13	Post-processing	B	1.0	R	$\sqrt{3}$	1	1	0.6	0.6	$\infty$
<b>Test sample related</b>										
14	Test sample positioning	A	3.3	N	1	1	1	3.3	3.3	71
15	Device holder uncertainty	A	3.4	N	1	1	1	3.4	3.4	5
16	Drift of output power	B	5.0	R	$\sqrt{3}$	1	1	2.9	2.9	$\infty$
<b>Phantom and set-up</b>										
17	Phantom uncertainty	B	4.0	R	$\sqrt{3}$	1	1	2.3	2.3	$\infty$
18	Liquid conductivity (target)	B	5.0	R	$\sqrt{3}$	0.64	0.43	1.8	1.2	$\infty$
19	Liquid conductivity (meas.)	A	2.06	N	1	0.64	0.43	1.32	0.89	43
20	Liquid permittivity (target)	B	5.0	R	$\sqrt{3}$	0.6	0.49	1.7	1.4	$\infty$
21	Liquid permittivity (meas.)	A	1.6	N	1	0.6	0.49	1.0	0.8	521



Combined standard uncertainty	$u_c = \sqrt{\sum_{i=1}^{21} c_i^2 u_i^2}$							9.55	9.43	257
Expanded uncertainty (confidence interval of 95 %)	$u_e = 2u_c$							19.1	18.9	

**16.2 Measurement Uncertainty for Normal SAR Tests (3~6GHz)**

No.	Error Description	Type	Uncertainty value	Probably Distribution	Div.	(Ci) 1g	(Ci) 10g	Std. Unc. (1g)	Std. Unc. (10g)	Degree of freedom
<b>Measurement system</b>										
1	Probe calibration	B	6.55	N	1	1	1	6.55	6.55	$\infty$
2	Isotropy	B	4.7	R	$\sqrt{3}$	0.7	0.7	1.9	1.9	$\infty$
3	Boundary effect	B	2.0	R	$\sqrt{3}$	1	1	1.2	1.2	$\infty$
4	Linearity	B	4.7	R	$\sqrt{3}$	1	1	2.7	2.7	$\infty$
5	Detection limit	B	1.0	R	$\sqrt{3}$	1	1	0.6	0.6	$\infty$
6	Readout electronics	B	0.3	R	$\sqrt{3}$	1	1	0.3	0.3	$\infty$
7	Response time	B	0.8	R	$\sqrt{3}$	1	1	0.5	0.5	$\infty$
8	Integration time	B	2.6	R	$\sqrt{3}$	1	1	1.5	1.5	$\infty$
9	RF ambient conditions-noise	B	0	R	$\sqrt{3}$	1	1	0	0	$\infty$
10	RFambient conditions-reflection	B	0	R	$\sqrt{3}$	1	1	0	0	$\infty$
11	Probe positioned mech. restrictions	B	0.8	R	$\sqrt{3}$	1	1	0.5	0.5	$\infty$
12	Probe positioning with respect to phantom shell	B	6.7	R	$\sqrt{3}$	1	1	3.9	3.9	$\infty$
13	Post-processing	B	4.0	R	$\sqrt{3}$	1	1	2.3	2.3	$\infty$
<b>Test sample related</b>										
14	Test sample positioning	A	3.3	N	1	1	1	3.3	3.3	71
15	Device holder uncertainty	A	3.4	N	1	1	1	3.4	3.4	5
16	Drift of output power	B	5.0	R	$\sqrt{3}$	1	1	2.9	2.9	$\infty$
<b>Phantom and set-up</b>										
17	Phantom uncertainty	B	4.0	R	$\sqrt{3}$	1	1	2.3	2.3	$\infty$
18	Liquid conductivity (target)	B	5.0	R	$\sqrt{3}$	0.64	0.43	1.8	1.2	$\infty$
19	Liquid conductivity (meas.)	A	2.06	N	1	0.64	0.43	1.32	0.89	43
20	Liquid permittivity (target)	B	5.0	R	$\sqrt{3}$	0.6	0.49	1.7	1.4	$\infty$

21	Liquid permittivity (meas.)	A	1.6	N	1	0.6	0.49	1.0	0.8	521
Combined standard uncertainty		$u_c' = \sqrt{\sum_{i=1}^{21} c_i^2 u_i^2}$						10.7	10.6	257
Expanded uncertainty (confidence interval of 95 %)		$u_e = 2u_c$						21.4	21.1	

### 16.3 Measurement Uncertainty for Fast SAR Tests (300MHz~3GHz)

No.	Error Description	Type	Uncertainty value	Probably Distribution	Div.	(Ci) 1g	(Ci) 10g	Std. Unc. (1g)	Std. Unc. (10g)	Degree of freedom
<b>Measurement system</b>										
1	Probe calibration	B	6.0	N	1	1	1	6.0	6.0	∞
2	Isotropy	B	4.7	R	$\sqrt{3}$	0.7	0.7	1.9	1.9	∞
3	Boundary effect	B	1.0	R	$\sqrt{3}$	1	1	0.6	0.6	∞
4	Linearity	B	4.7	R	$\sqrt{3}$	1	1	2.7	2.7	∞
5	Detection limit	B	1.0	R	$\sqrt{3}$	1	1	0.6	0.6	∞
6	Readout electronics	B	0.3	R	$\sqrt{3}$	1	1	0.3	0.3	∞
7	Response time	B	0.8	R	$\sqrt{3}$	1	1	0.5	0.5	∞
8	Integration time	B	2.6	R	$\sqrt{3}$	1	1	1.5	1.5	∞
9	RF ambient conditions-noise	B	0	R	$\sqrt{3}$	1	1	0	0	∞
10	RFambient conditions-reflection	B	0	R	$\sqrt{3}$	1	1	0	0	∞
11	Probe positioned mech. Restrictions	B	0.4	R	$\sqrt{3}$	1	1	0.2	0.2	∞
12	Probe positioning with respect to phantom shell	B	2.9	R	$\sqrt{3}$	1	1	1.7	1.7	∞
13	Post-processing	B	1.0	R	$\sqrt{3}$	1	1	0.6	0.6	∞
14	Fast SAR z-Approximation	B	7.0	R	$\sqrt{3}$	1	1	4.0	4.0	∞
<b>Test sample related</b>										
15	Test sample positioning	A	3.3	N	1	1	1	3.3	3.3	71
16	Device holder uncertainty	A	3.4	N	1	1	1	3.4	3.4	5
17	Drift of output power	B	5.0	R	$\sqrt{3}$	1	1	2.9	2.9	∞
<b>Phantom and set-up</b>										
18	Phantom uncertainty	B	4.0	R	$\sqrt{3}$	1	1	2.3	2.3	∞
19	Liquid conductivity (target)	B	5.0	R	$\sqrt{3}$	0.64	0.43	1.8	1.2	∞

20	Liquid conductivity (meas.)	A	2.06	N	1	0.64	0.43	1.32	0.89	43
21	Liquid permittivity (target)	B	5.0	R	$\sqrt{3}$	0.6	0.49	1.7	1.4	$\infty$
22	Liquid permittivity (meas.)	A	1.6	N	1	0.6	0.49	1.0	0.8	521
Combined standard uncertainty		$u_c = \sqrt{\sum_{i=1}^{22} c_i^2 u_i^2}$						10.4	10.3	257
Expanded uncertainty (confidence interval of 95 %)		$u_e = 2u_c$						20.8	20.6	

#### 16.4 Measurement Uncertainty for Fast SAR Tests (3~6GHz)

No.	Error Description	Type	Uncertainty value	Probably Distribution	Div.	(Ci) 1g	(Ci) 10g	Std. Unc. (1g)	Std. Unc. (10g)	Degree of freedom
<b>Measurement system</b>										
1	Probe calibration	B	6.55	N	1	1	1	6.55	6.55	$\infty$
2	Isotropy	B	4.7	R	$\sqrt{3}$	0.7	0.7	1.9	1.9	$\infty$
3	Boundary effect	B	2.0	R	$\sqrt{3}$	1	1	1.2	1.2	$\infty$
4	Linearity	B	4.7	R	$\sqrt{3}$	1	1	2.7	2.7	$\infty$
5	Detection limit	B	1.0	R	$\sqrt{3}$	1	1	0.6	0.6	$\infty$
6	Readout electronics	B	0.3	R	$\sqrt{3}$	1	1	0.3	0.3	$\infty$
7	Response time	B	0.8	R	$\sqrt{3}$	1	1	0.5	0.5	$\infty$
8	Integration time	B	2.6	R	$\sqrt{3}$	1	1	1.5	1.5	$\infty$
9	RF ambient conditions-noise	B	0	R	$\sqrt{3}$	1	1	0	0	$\infty$
10	RF ambient conditions-reflection	B	0	R	$\sqrt{3}$	1	1	0	0	$\infty$
11	Probe positioned mech. Restrictions	B	0.8	R	$\sqrt{3}$	1	1	0.5	0.5	$\infty$
12	Probe positioning with respect to phantom shell	B	6.7	R	$\sqrt{3}$	1	1	3.9	3.9	$\infty$
13	Post-processing	B	1.0	R	$\sqrt{3}$	1	1	0.6	0.6	$\infty$
14	Fast SAR z-Approximation	B	14.0	R	$\sqrt{3}$	1	1	8.1	8.1	$\infty$
<b>Test sample related</b>										
15	Test sample positioning	A	3.3	N	1	1	1	3.3	3.3	71
16	Device holder uncertainty	A	3.4	N	1	1	1	3.4	3.4	5

17	Drift of output power	B	5.0	R	$\sqrt{3}$	1	1	2.9	2.9	$\infty$
<b>Phantom and set-up</b>										
18	Phantom uncertainty	B	4.0	R	$\sqrt{3}$	1	1	2.3	2.3	$\infty$
19	Liquid conductivity (target)	B	5.0	R	$\sqrt{3}$	0.64	0.43	1.8	1.2	$\infty$
20	Liquid conductivity (meas.)	A	2.06	N	1	0.64	0.43	1.32	0.89	43
21	Liquid permittivity (target)	B	5.0	R	$\sqrt{3}$	0.6	0.49	1.7	1.4	$\infty$
22	Liquid permittivity (meas.)	A	1.6	N	1	0.6	0.49	1.0	0.8	521
Combined standard uncertainty		$u_c = \sqrt{\sum_{i=1}^{22} c_i^2 u_i^2}$						13.5	13.4	257
Expanded uncertainty (confidence interval of 95 %)		$u_e = 2u_c$						27.0	26.8	

## 17 MAIN TEST INSTRUMENTS

**Table 17.1: List of Main Instruments**

No.	Name	Type	Serial Number	Calibration Date	Valid Period
01	Network analyzer	E5071C	MY46110673	January 14, 2021	One year
02	Power meter	NRP2	101919	May 12, 2020	One year
03	Power sensor	NRP-Z91	101547		
04	Signal Generator	E4438C	MY49071430	February 25, 2020	One Year
05	Amplifier	60S1G4	0331848	No Calibration Requested	
06	BTS	CMW500	159889	January 13, 2021	One year
07	E-field Probe	SPEAG EX3DV4	7307	May 29, 2020	One year
08	DAE	SPEAG DAE4	536	November 6, 2020	One year
09	Dipole Validation Kit	SPEAG D750V3	1017	July 24,2020	One year
10	Dipole Validation Kit	SPEAG D835V2	4d069	July 24,,2020	One year
11	Dipole Validation Kit	SPEAG D1750V2	1003	July 24, 2020	One year
12	Dipole Validation Kit	SPEAG D1900V2	5d101	July 28,2020	One year
13	Dipole Validation Kit	SPEAG D2450V2	853	July 21,2020	One year
14	Dipole Validation Kit	SPEAG D2300V2	1018	July 21,2020	One year
15	Dipole Validation Kit	SPEAG D5GHzV2	1060	July 27,2020	One year

\*\*\*END OF REPORT BODY\*\*\*

## ANNEX A Graph Results

LTE1900-FDD2\_CH19100 1RB-Middle Front5mm

Date: 2/16/2021

Electronics: DAE4 Sn536

Medium: head 1900 MHz

Medium parameters used:  $f = 1900$  MHz;  $\sigma = 1.411$  mho/m;  $\epsilon_r = 39.38$ ;  $\rho = 1000$  kg/m<sup>3</sup>

Ambient Temperature: 22.5°C, Liquid Temperature: 22.3°C

Communication System: LTE1900-FDD2 1900 MHz Duty Cycle: 1:1

Probe: EX3DV4 – SN7307 ConvF(8.33,8.33,8.33)

**Area Scan (71x121x1):** Interpolated grid:  $dx=1.000$  mm,  $dy=1.000$  mm

Maximum value of SAR (interpolated) = 1.27 W/kg

**Zoom Scan (7x7x7)/Cube 0:** Measurement grid:  $dx=5$ mm,  $dy=5$ mm,  $dz=5$ mm

Reference Value = 7.907 V/m; Power Drift = -0.02 dB

Peak SAR (extrapolated) = 1.48 W/kg

**SAR(1 g) = 0.835 W/kg; SAR(10 g) = 0.479 W/kg**

Maximum value of SAR (measured) = 1.21W/kg

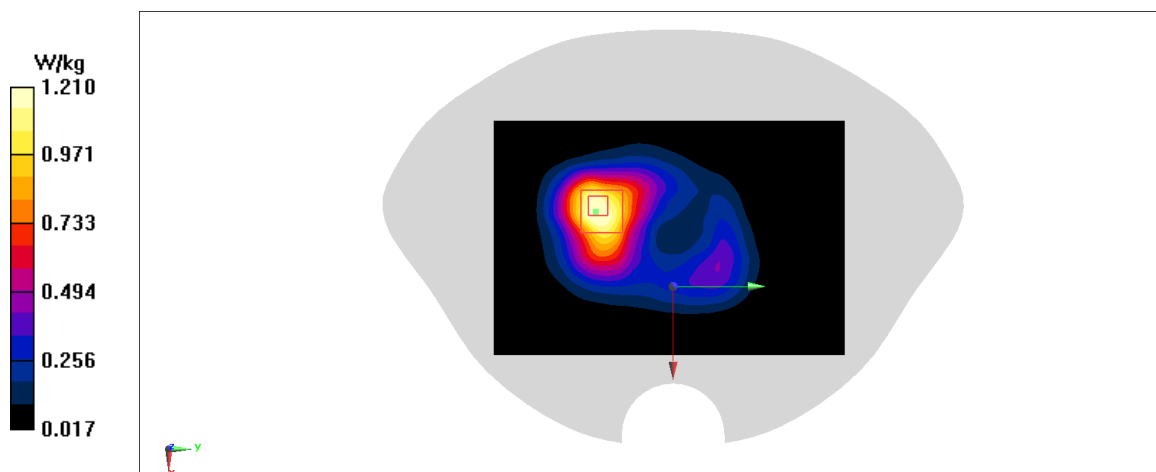

Fig A.1

**LTE850-FDD5\_CH20600 1RB-Mid Rear 5mm**

Date: 2/14/2021

Electronics: DAE4 Sn536

Medium: head 835 MHz

Medium parameters used:  $f = 844 \text{ MHz}$ ;  $\sigma = 0.895 \text{ mho/m}$ ;  $\epsilon_r = 40.91$ ;  $\rho = 1000 \text{ kg/m}^3$ Ambient Temperature:  $22.5^\circ\text{C}$ , Liquid Temperature:  $22.3^\circ\text{C}$ 

Communication System: LTE850-FDD5 844 MHz Duty Cycle: 1:1

Probe: EX3DV4 – SN7307 ConvF(10.2,10.2,10.2)

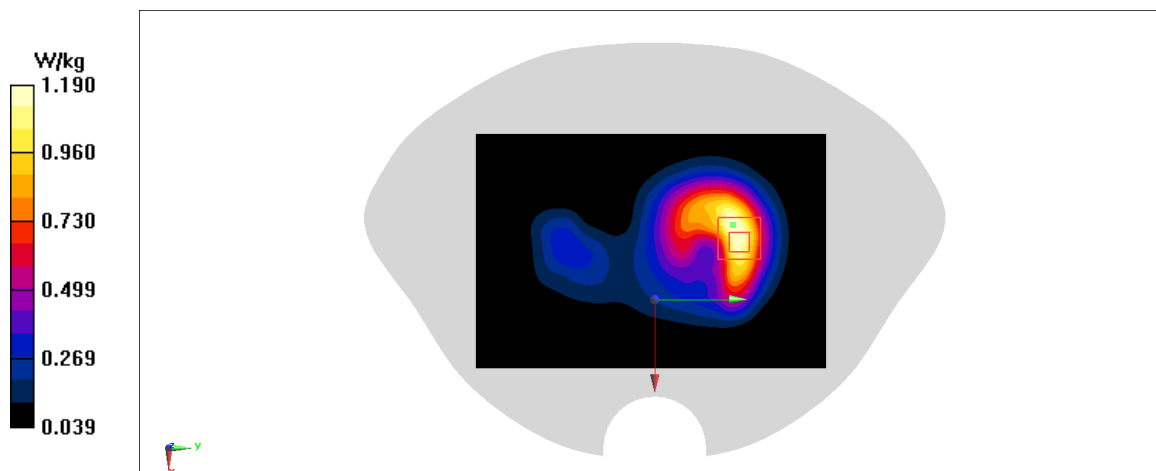
**Area Scan (71x121x1):** Interpolated grid:  $dx=1.000 \text{ mm}$ ,  $dy=1.000 \text{ mm}$ Maximum value of SAR (interpolated) =  $1.23 \text{ W/kg}$ **Zoom Scan (7x7x7)/Cube 0:** Measurement grid:  $dx=5\text{mm}$ ,  $dy=5\text{mm}$ ,  $dz=5\text{mm}$ Reference Value =  $17.78 \text{ V/m}$ ; Power Drift =  $0.04 \text{ dB}$ Peak SAR (extrapolated) =  $1.47 \text{ W/kg}$ **SAR(1 g) =  $0.793 \text{ W/kg}$ ; SAR(10 g) =  $0.456 \text{ W/kg}$** Maximum value of SAR (measured) =  $1.19 \text{ W/kg}$ **Fig A.2**

**LTE700-FDD12\_CH23060 1RB-MID Front 5mm**

Date: 2/13/2021

Electronics: DAE4 Sn536

Medium: head 750 MHz

Medium parameters used:  $f = 704 \text{ MHz}$ ;  $\sigma = 0.856 \text{ mho/m}$ ;  $\epsilon_r = 41.8$ ;  $\rho = 1000 \text{ kg/m}^3$

Ambient Temperature:  $22.5^\circ\text{C}$ , Liquid Temperature:  $22.3^\circ\text{C}$

Communication System: LTE700-FDD12 704 MHz Duty Cycle: 1:1

Probe: EX3DV4 – SN7307 ConvF(10.41,10.41,10.41)

**Area Scan (71x121x1):** Interpolated grid:  $dx=1.000 \text{ mm}$ ,  $dy=1.000 \text{ mm}$

Maximum value of SAR (interpolated) =  $0.750 \text{ W/kg}$

**Zoom Scan (7x7x7)/Cube 0:** Measurement grid:  $dx=5\text{mm}$ ,  $dy=5\text{mm}$ ,  $dz=5\text{mm}$

Reference Value =  $20.73 \text{ V/m}$ ; Power Drift =  $0.04 \text{ dB}$

Peak SAR (extrapolated) =  $0.886 \text{ W/kg}$

**SAR(1 g) =  $0.571 \text{ W/kg}$ ; SAR(10 g) =  $0.402 \text{ W/kg}$**

Maximum value of SAR (measured) =  $0.758 \text{ W/kg}$

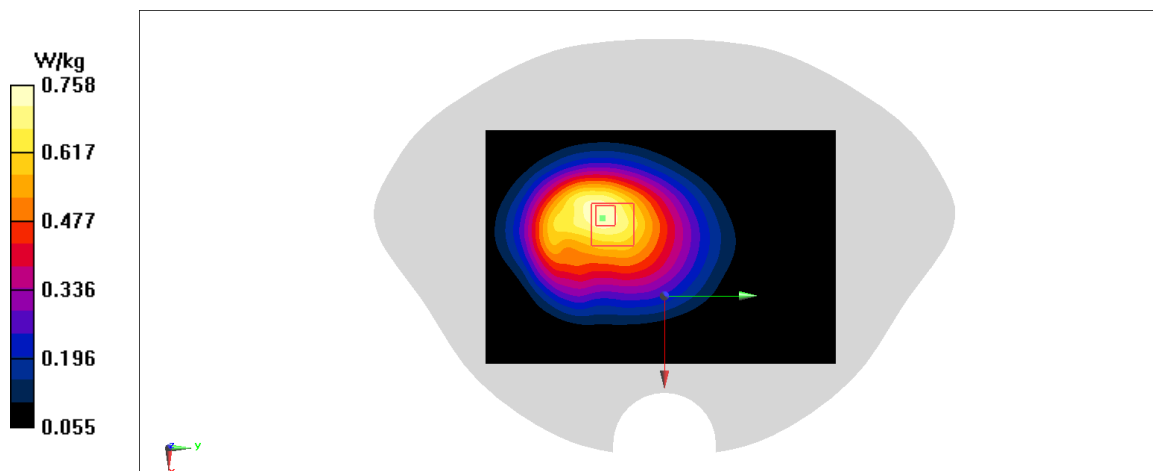

**Fig A.3**



**LTE700-FDD14\_CH23330 1RB-Mid Rear 5mm**

Date: 2/13/2021

Electronics: DAE4 Sn536

Medium: head 750 MHz

Medium parameters used:  $f = 793 \text{ MHz}$ ;  $\sigma = 0.941 \text{ mho/m}$ ;  $\epsilon_r = 41.69$ ;  $\rho = 1000 \text{ kg/m}^3$

Ambient Temperature:  $22.5^\circ\text{C}$ , Liquid Temperature:  $22.3^\circ\text{C}$

Communication System: LTE700-FDD14 793 MHz Duty Cycle: 1:1

Probe: EX3DV4 – SN7307 ConvF(10.41,10.41,10.41)

**Area Scan (71x121x1):** Interpolated grid:  $dx=1.000 \text{ mm}$ ,  $dy=1.000 \text{ mm}$

Maximum value of SAR (interpolated) =  $0.674 \text{ W/kg}$

**Zoom Scan (7x7x7)/Cube 0:** Measurement grid:  $dx=5\text{mm}$ ,  $dy=5\text{mm}$ ,  $dz=5\text{mm}$

Reference Value =  $23.49 \text{ V/m}$ ; Power Drift =  $-0.03 \text{ dB}$

Peak SAR (extrapolated) =  $0.756 \text{ W/kg}$

**SAR(1 g) =  $0.547 \text{ W/kg}$ ; SAR(10 g) =  $0.407 \text{ W/kg}$**

Maximum value of SAR (measured) =  $0.682 \text{ W/kg}$

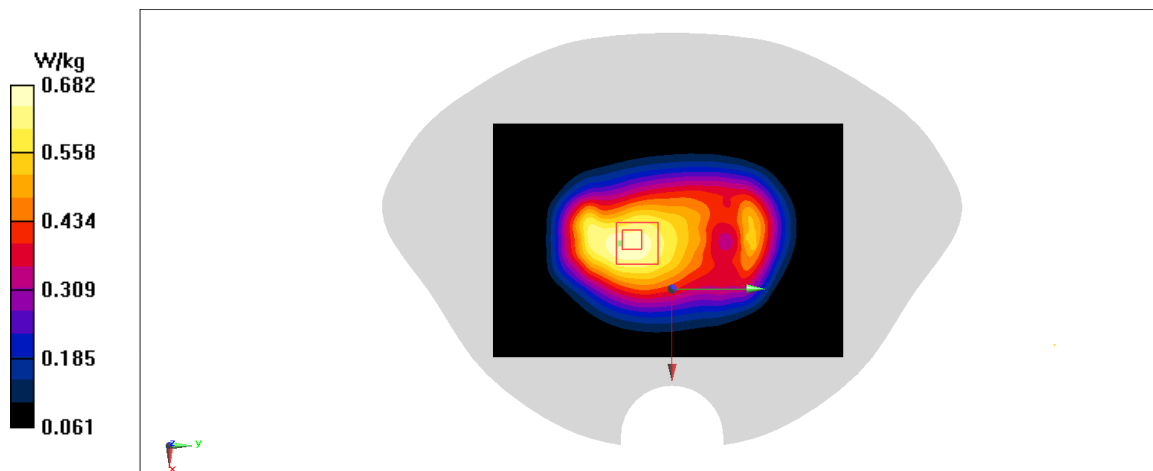

**Fig A.4**

**LTE2300-FDD30\_CH27710 1RB-Mid Front 5mm**

Date: 2/17/2021

Electronics: DAE4 Sn536

Medium: head 2300 MHz

Medium parameters used:  $f = 2310$  MHz;  $\sigma = 1.676$  mho/m;  $\epsilon_r = 39.15$ ;  $\rho = 1000$  kg/m<sup>3</sup>

Ambient Temperature: 22.5°C, Liquid Temperature: 22.3°C

Communication System: LTE2300-FDD30 2310 MHz Duty Cycle: 1:1

Probe: EX3DV4 – SN7307 ConvF(8.15,8.15,8.15)

**Area Scan (71x121x1):** Interpolated grid: dx=1.000 mm, dy=1.000 mm

Maximum value of SAR (interpolated) = 1.14 W/kg

**Zoom Scan (7x7x7)/Cube 0:** Measurement grid: dx=5mm, dy=5mm, dz=5mm

Reference Value = 5.396 V/m; Power Drift = 0.06 dB

Peak SAR (extrapolated) = 1.45 W/kg

**SAR(1 g) = 0.736 W/kg; SAR(10 g) = 0.357 W/kg**

Maximum value of SAR (measured) = 1.18W/kg

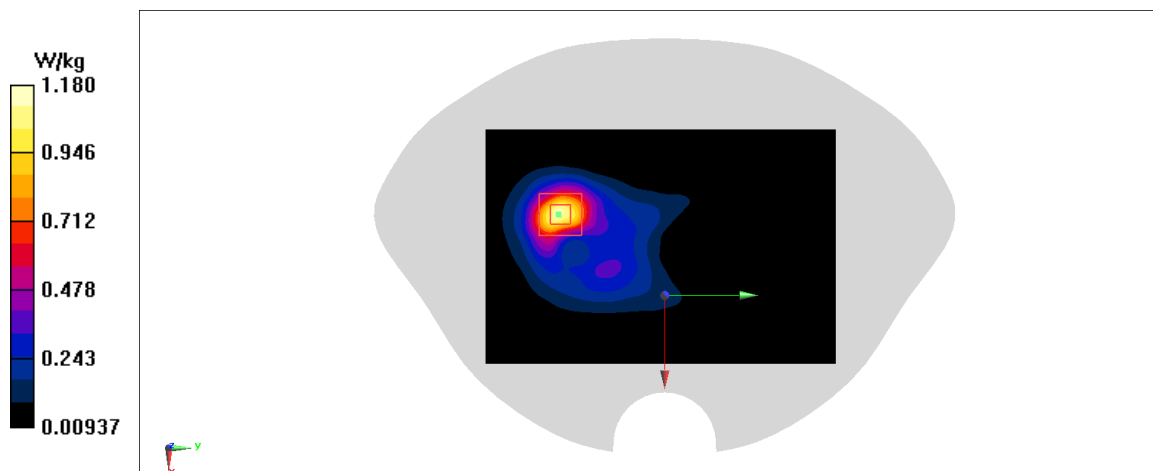
**Fig A.5**

**LTE1700-FDD66\_CH132572 1RB-Mid Front 5mm**

Date: 2/15/2021

Electronics: DAE4 Sn536

Medium: head 1750 MHz

Medium parameters used:  $f = 1770$  MHz;  $\sigma = 1.356$  mho/m;  $\epsilon_r = 40.18$ ;  $\rho = 1000$  kg/m<sup>3</sup>

Ambient Temperature: 22.5°C, Liquid Temperature: 22.3°C

Communication System: LTE1700-FDD66 2310 MHz Duty Cycle: 1:1

Probe: EX3DV4 – SN7307 ConvF(8.64,8.64,8.64)

**Area Scan (71x121x1):** Interpolated grid: dx=1.000 mm, dy=1.000 mm

Maximum value of SAR (interpolated) = 1.07 W/kg

**Zoom Scan (7x7x7)/Cube 0:** Measurement grid: dx=5mm, dy=5mm, dz=5mm

Reference Value = 7.996 V/m; Power Drift = 0.03 dB

Peak SAR (extrapolated) = 1.13 W/kg

**SAR(1 g) = 0.676 W/kg; SAR(10 g) = 0.404 W/kg**

Maximum value of SAR (measured) = 0.958 W/kg

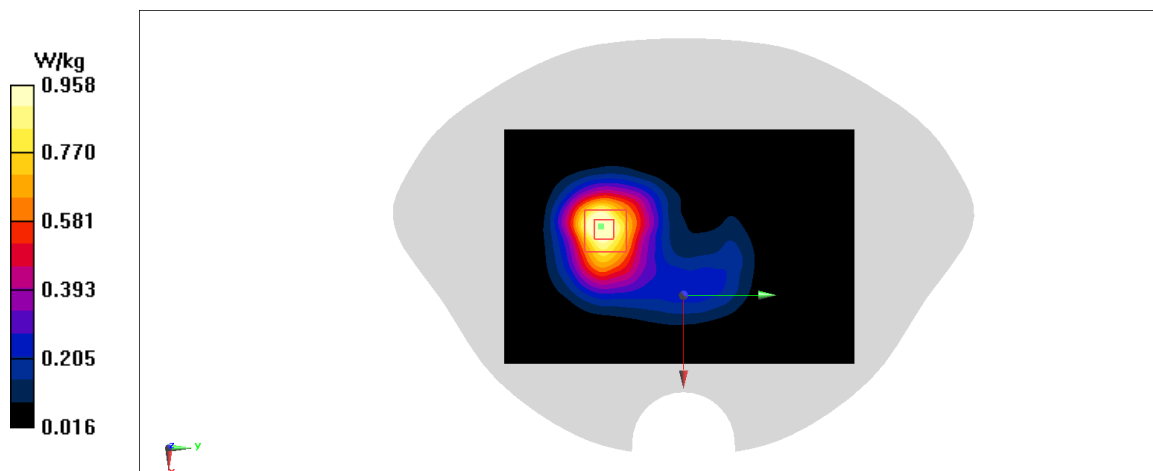

**Fig A.6**

**WLAN2450\_CH1 Top Edge 5mm 14dB 2000**

Date: 2/18/2021

Electronics: DAE4 Sn536

Medium: head 2450 MHz

Medium parameters used:  $f = 2412$ ;  $\sigma = 1.778$  mho/m;  $\epsilon_r = 39.1$ ;  $\rho = 1000$  kg/m<sup>3</sup>

Ambient Temperature: 22.5°C, Liquid Temperature: 22.3°C

Communication System: WLAN2450 2412 Duty Cycle: 1:1

Probe: EX3DV4 – SN7307 ConvF(7.77,7.77,7.77)

**Area Scan (71x121x1):** Interpolated grid: dx=1.000 mm, dy=1.000 mm

Maximum value of SAR (interpolated) = 0.923 W/kg

**Zoom Scan (7x7x7)/Cube 0:** Measurement grid: dx=5mm, dy=5mm, dz=5mm

Reference Value = 13.87 V/m; Power Drift = -0.07 dB

Peak SAR (extrapolated) = 1.20 W/kg

**SAR(1 g) = 0.53 W/kg; SAR(10 g) = 0.238 W/kg**

Maximum value of SAR (measured) = 0.932 W/kg

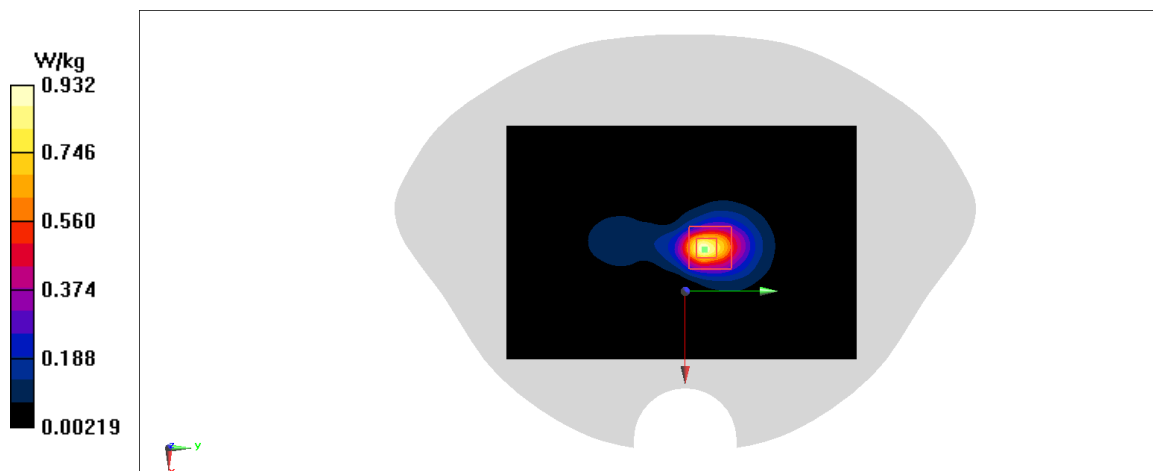

Fig A.7

**WLAN5G\_CH144 11a-6M 10.5dB 10000 Front 5mm**

Date: 2/18/2021

Electronics: DAE4 Sn536

Medium: head 2450 MHz

Medium parameters used:  $f = 5720$ ;  $\sigma = 4.921$  mho/m;  $\epsilon_r = 35.13$ ;  $\rho = 1000$  kg/m<sup>3</sup>

Ambient Temperature: 22.5°C, Liquid Temperature: 22.3°C

Communication System: WLAN2450 5720 Duty Cycle: 1:1

Probe: EX3DV4 – SN7307 ConvF(7.77,7.77,7.77)

**Area Scan (71x121x1):** Interpolated grid: dx=1.000 mm, dy=1.000 mm

Maximum value of SAR (interpolated) = 1.21 W/kg

**Zoom Scan (7x7x7)/Cube 0:** Measurement grid: dx=5mm, dy=5mm, dz=5mm

Reference Value = 2.968 V/m; Power Drift = -0.03 dB

Peak SAR (extrapolated) = 1.79 W/kg

**SAR(1 g) = 0.5225084649 W/kg; SAR(10 g) = 0.118 W/kg**

Maximum value of SAR (measured) = 1.11W/kg

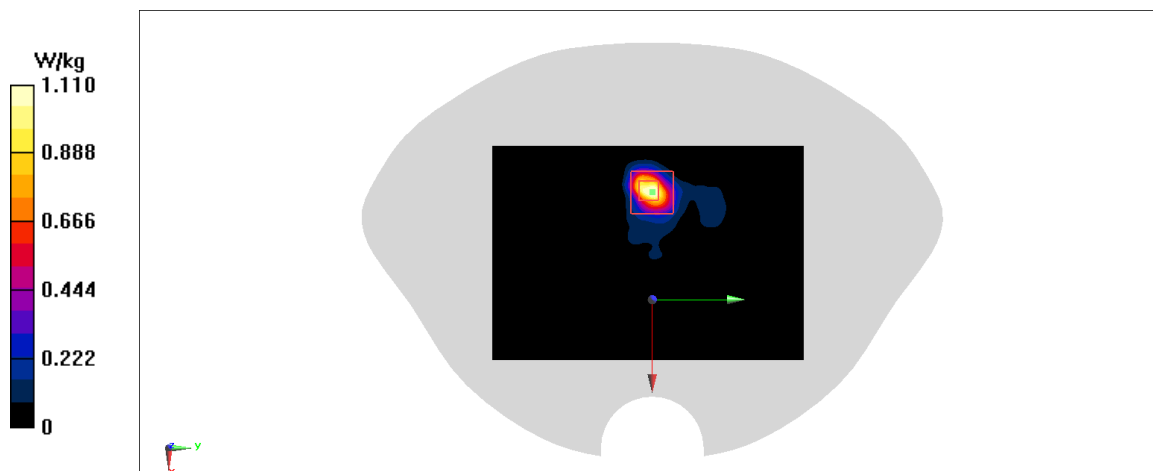

**Fig A.8**

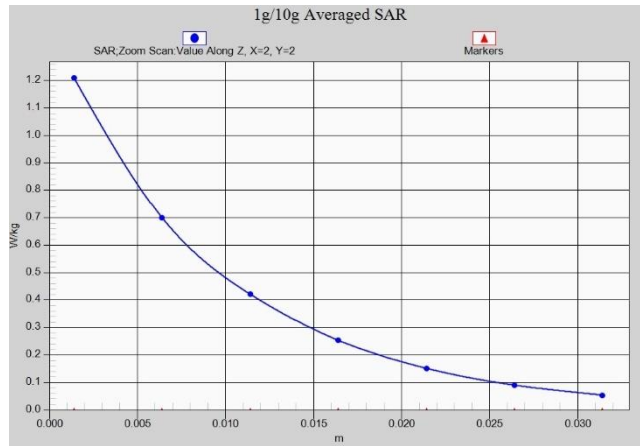

**Z-Scan at power reference point (LTEB2)**

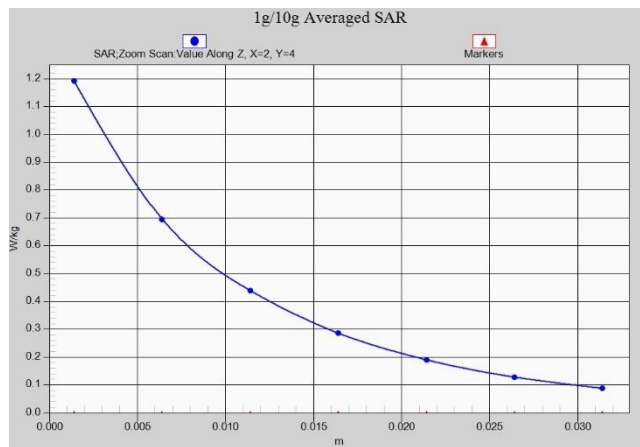

**Z-Scan at power reference point (LTEB5)**

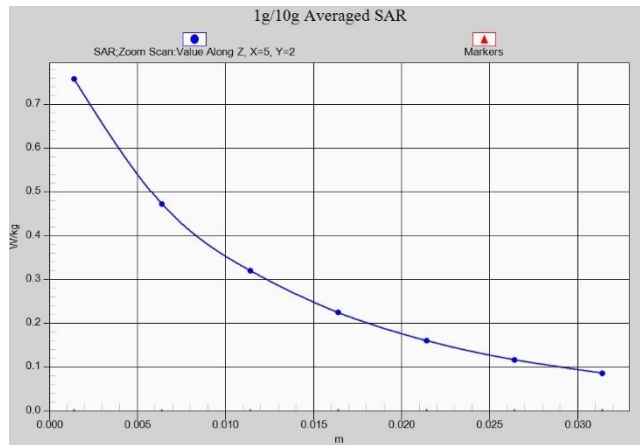

**Z-Scan at power reference point (LTEB12)**

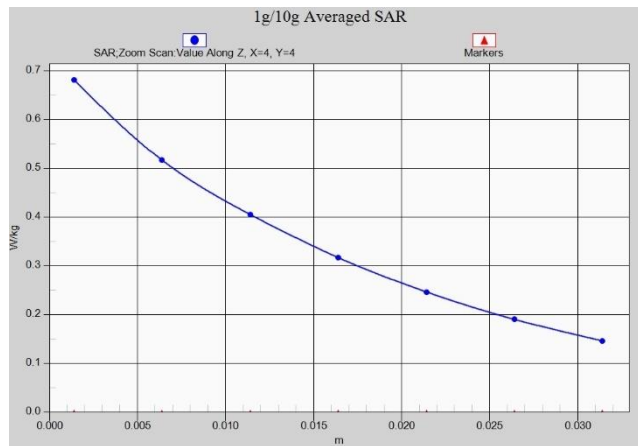

**Z-Scan at power reference point (LTEB14)**

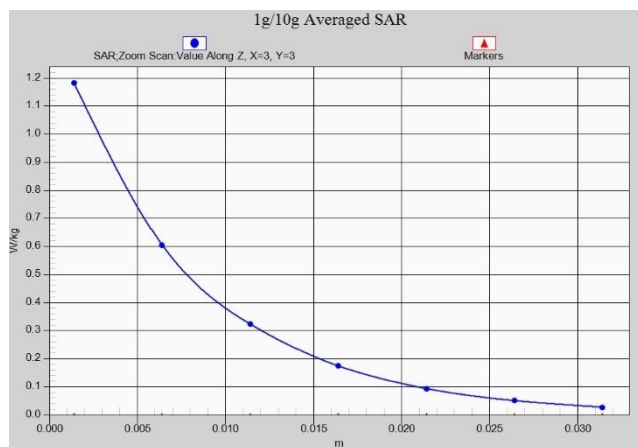

**Z-Scan at power reference point (LTEB30)**

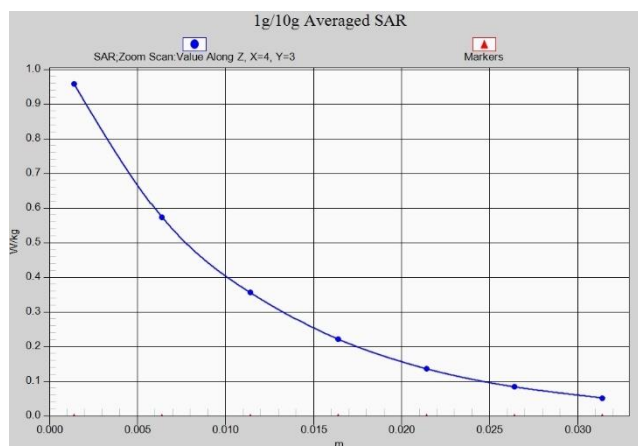

**Z-Scan at power reference point (LTEB66)**

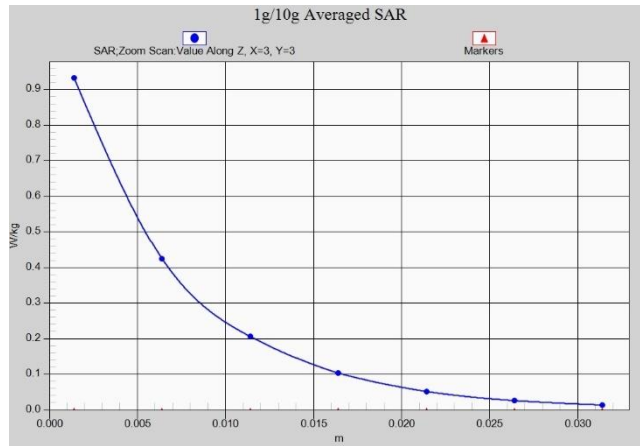

**Z-Scan at power reference point (WIFI2.4G)**

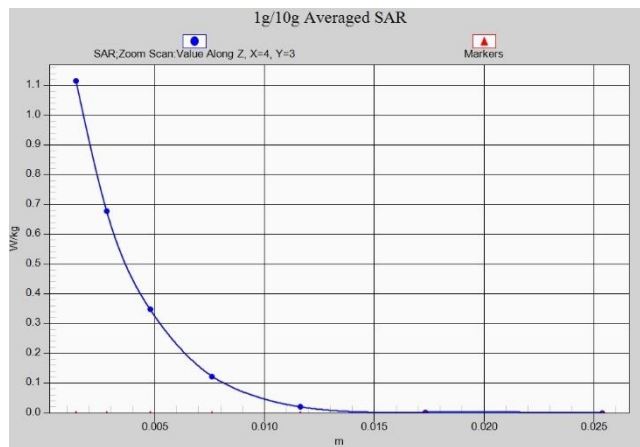

**Z-Scan at power reference point (WIFI5G)**



## ANNEX B System Verification Results

### 750 MHz

Date: 2/13/2021

Electronics: DAE4 Sn536

Medium: Head 750 MHz

Medium parameters used:  $f = 750 \text{ MHz}$ ;  $\sigma = 0.89 \text{ mho/m}$ ;  $\epsilon_r = 42.5$ ;  $\rho = 1000 \text{ kg/m}^3$

Ambient Temperature: 22.5°C Liquid Temperature: 22.3°C

Communication System: CW Frequency: 750 MHz Duty Cycle: 1:1

Probe: EX3DV4 – SN7307 ConvF(10.41,10.41,10.41)

**System Validation /Area Scan (81x191x1):** Interpolated grid:  $dx=1.000 \text{ mm}$ ,  $dy=1.000 \text{ mm}$

Reference Value = 58.74 V/m; Power Drift = -0.02

**Fast SAR: SAR(1 g) = 2.19 W/kg; SAR(10 g) = 1.38 W/kg**

Maximum value of SAR (interpolated) = 2.85 W/kg

**System Validation /Zoom Scan (7x7x7)/Cube 0:** Measurement grid:  $dx=5\text{mm}$ ,  $dy=5\text{mm}$ ,  $dz=5\text{mm}$

Reference Value =58.74 V/m; Power Drift = -0.02 dB

Peak SAR (extrapolated) = 3.28 W/kg

**SAR(1 g) = 2.16 W/kg; SAR(10 g) = 1.36 W/kg**

Maximum value of SAR (measured) = 2.85 W/kg

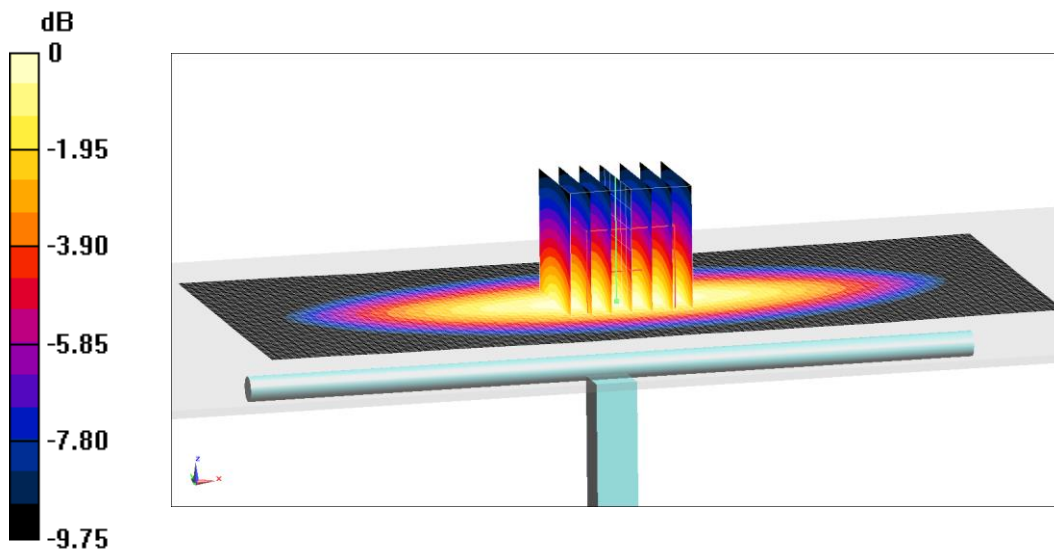

0 dB = 2.85 W/kg = 4.55 dB W/kg

**Fig.B.1 validation 750 MHz 250mW**

**835 MHz**

Date: 2/14/2021

Electronics: DAE4 Sn536

Medium: Head 835 MHz

Medium parameters used:  $f = 835 \text{ MHz}$ ;  $\sigma = 0.888 \text{ mho/m}$ ;  $\epsilon_r = 40.69$ ;  $\rho = 1000 \text{ kg/m}^3$

Ambient Temperature:  $22.5^\circ\text{C}$  Liquid Temperature:  $22.3^\circ\text{C}$

Communication System: CW Frequency:  $835 \text{ MHz}$  Duty Cycle: 1:1

Probe: EX3DV4 – SN7307 ConvF(10.2,10.2,10.2)

**System Validation /Area Scan (81x191x1):** Interpolated grid:  $dx=1.000 \text{ mm}$ ,  $dy=1.000 \text{ mm}$

Reference Value =  $62.83 \text{ V/m}$ ; Power Drift = 0.1

**Fast SAR: SAR(1 g) =  $2.37 \text{ W/kg}$ ; SAR(10 g) =  $1.53 \text{ W/kg}$**

Maximum value of SAR (interpolated) =  $3.19 \text{ W/kg}$

**System Validation /Zoom Scan (7x7x7)/Cube 0:** Measurement grid:  $dx=5\text{mm}$ ,  $dy=5\text{mm}$ ,  $dz=5\text{mm}$

Reference Value =  $62.83 \text{ V/m}$ ; Power Drift = 0.1 dB

Peak SAR (extrapolated) =  $3.66 \text{ W/kg}$

**SAR(1 g) =  $2.43 \text{ W/kg}$ ; SAR(10 g) =  $1.55 \text{ W/kg}$**

Maximum value of SAR (measured) =  $3.27 \text{ W/kg}$

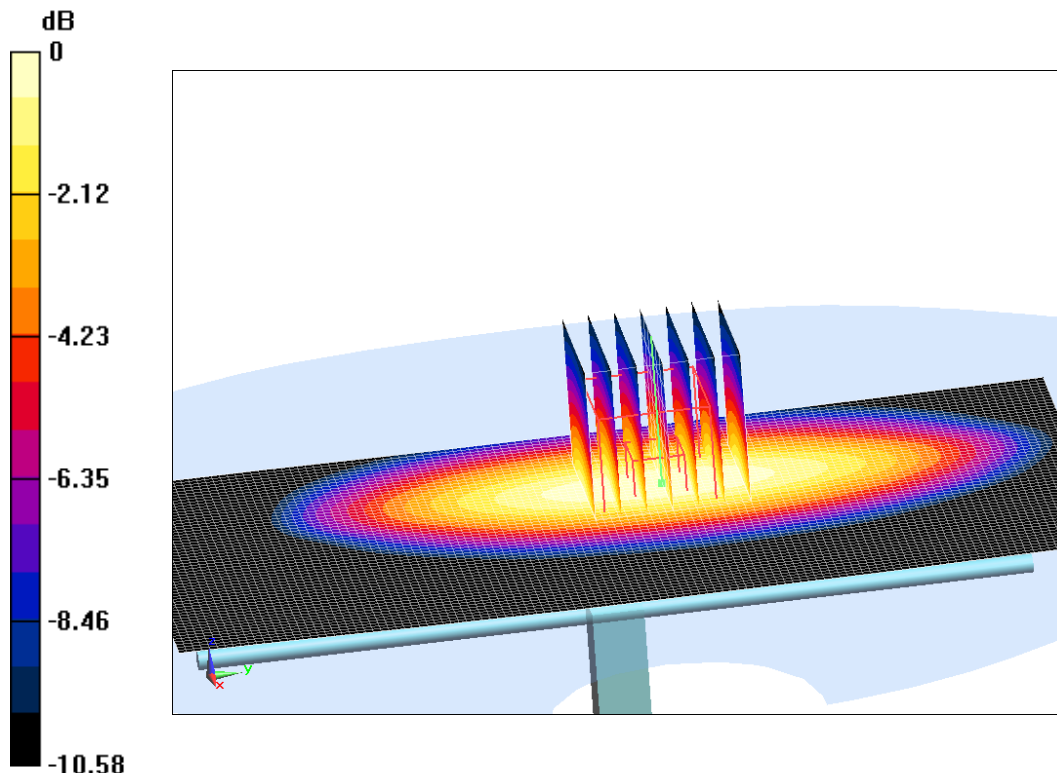

0 dB =  $3.27 \text{ W/kg}$  =  $5.15 \text{ dB W/kg}$

**Fig.B.2 validation 835 MHz 250mW**

**1750 MHz**

Date: 2/15/2021

Electronics: DAE4 Sn536

Medium: Head 1750 MHz

Medium parameters used:  $f = 1750 \text{ MHz}$ ;  $\sigma = 1.354 \text{ mho/m}$ ;  $\epsilon_r = 40.2$ ;  $\rho = 1000 \text{ kg/m}^3$

Ambient Temperature:  $22.5^\circ\text{C}$  Liquid Temperature:  $22.3^\circ\text{C}$

Communication System: CW Frequency: 1750 MHz Duty Cycle: 1:1

Probe: EX3DV4 – SN7307 ConvF(8.64,8.64,8.64)

**System Validation /Area Scan (81x191x1):** Interpolated grid:  $dx=1.000 \text{ mm}$ ,  $dy=1.000 \text{ mm}$

Reference Value = 106.22 V/m; Power Drift = 0.01

**Fast SAR: SAR(1 g) = 9.29 W/kg; SAR(10 g) = 4.87 W/kg**

Maximum value of SAR (interpolated) = 13.78 W/kg

**System Validation /Zoom Scan (7x7x7)/Cube 0:** Measurement grid:  $dx=5\text{mm}$ ,  $dy=5\text{mm}$ ,  $dz=5\text{mm}$

Reference Value =106.22 V/m; Power Drift = 0.01 dB

Peak SAR (extrapolated) = 16.83 W/kg

**SAR(1 g) = 9.09 W/kg; SAR(10 g) = 4.87 W/kg**

Maximum value of SAR (measured) = 13.92 W/kg

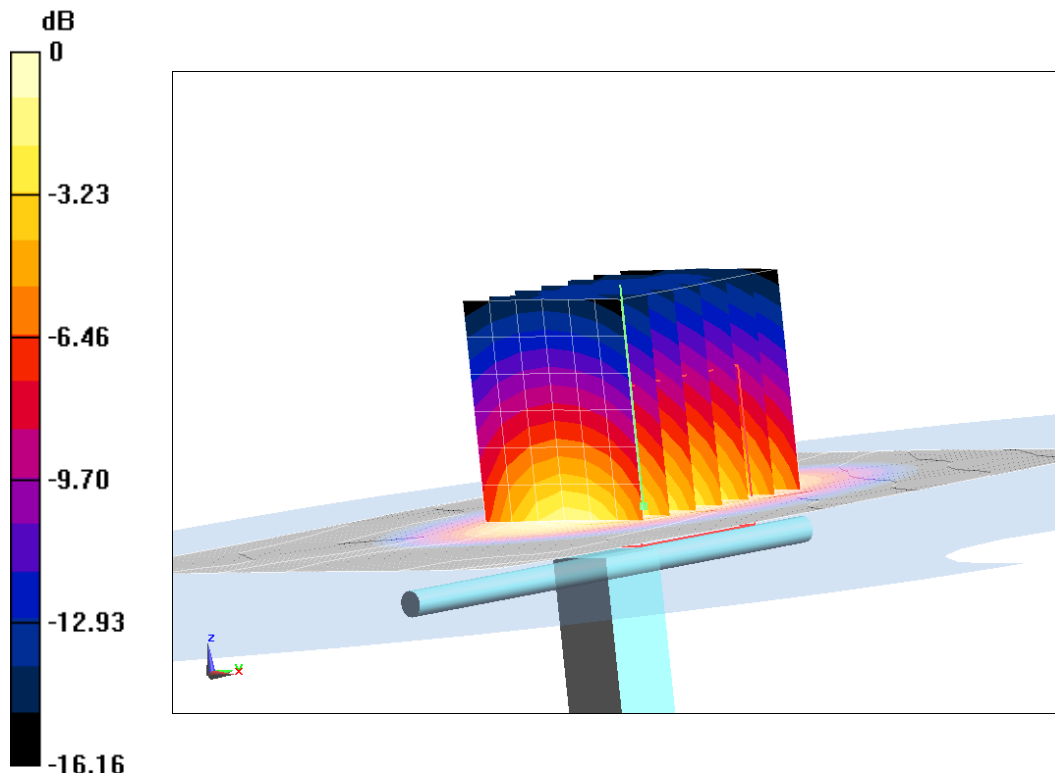

0 dB = 13.92 W/kg = 11.44 dB W/kg

**Fig.B.3 validation 1750 MHz 250mW**

**1900 MHz**

Date: 2/16/2021

Electronics: DAE4 Sn536

Medium: Body 1900 MHz

Medium parameters used:  $f = 1900 \text{ MHz}$ ;  $\sigma = 1.411 \text{ mho/m}$ ;  $\epsilon_r = 39.38$ ;  $\rho = 1000 \text{ kg/m}^3$

Ambient Temperature:  $22.5^\circ\text{C}$  Liquid Temperature:  $22.3^\circ\text{C}$

Communication System: CW Frequency: 1900 MHz Duty Cycle: 1:1

Probe: EX3DV4 – SN7307 ConvF(8.33,8.33,8.33)

**System Validation /Area Scan (81x191x1):** Interpolated grid:  $dx=1.000 \text{ mm}$ ,  $dy=1.000 \text{ mm}$

Reference Value = 103.64 V/m; Power Drift = -0.04

**Fast SAR: SAR(1 g) = 9.84 W/kg; SAR(10 g) = 5.18 W/kg**

Maximum value of SAR (interpolated) = 14.05 W/kg

**System Validation /Zoom Scan (7x7x7)/Cube 0:** Measurement grid:  $dx=5\text{mm}$ ,  $dy=5\text{mm}$ ,  $dz=5\text{mm}$

Reference Value =103.64 V/m; Power Drift = -0.04 dB

Peak SAR (extrapolated) = 16.67 W/kg

**SAR(1 g) = 9.94 W/kg; SAR(10 g) = 5.29 W/kg**

Maximum value of SAR (measured) = 14.21 W/kg

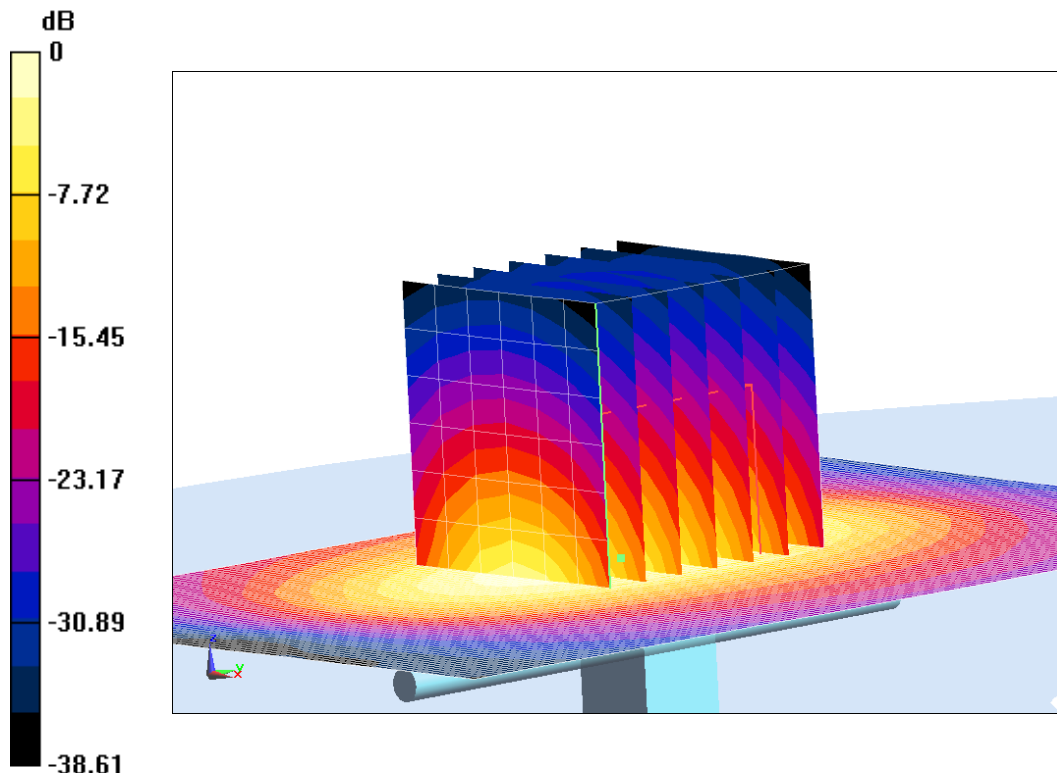

0 dB = 14.21 W/kg = 11.53 dB W/kg

**Fig.B.4 validation 1900 MHz 250mW**

**2300 MHz**

Date: 2/17/2021

Electronics: DAE4 Sn536

Medium: Head 2300 MHz

Medium parameters used:  $f = 2300$  MHz;  $\sigma = 1.687$  mho/m;  $\epsilon_r = 40.14$ ;  $\rho = 1000$  kg/m<sup>3</sup>

Ambient Temperature: 22.5°C Liquid Temperature: 22.3°C

Communication System: CW Frequency: 2300 MHz Duty Cycle: 1:1

Probe: EX3DV4 – SN7307 ConvF(8.15,8.15,8.15)

**System Validation /Area Scan (81x191x1):** Interpolated grid: dx=1.000 mm, dy=1.000 mm

Reference Value = 118.49 V/m; Power Drift = -0.04

**Fast SAR: SAR(1 g) = 12.57 W/kg; SAR(10 g) = 5.97 W/kg**

Maximum value of SAR (interpolated) = 19.94 W/kg

**System Validation /Zoom Scan (7x7x7)/Cube 0:** Measurement grid: dx=5mm, dy=5mm, dz=5mm

Reference Value =118.49 V/m; Power Drift = -0.04 dB

Peak SAR (extrapolated) = 23.34 W/kg

**SAR(1 g) = 12.31 W/kg; SAR(10 g) = 6.02 W/kg**

Maximum value of SAR (measured) = 19.67 W/kg

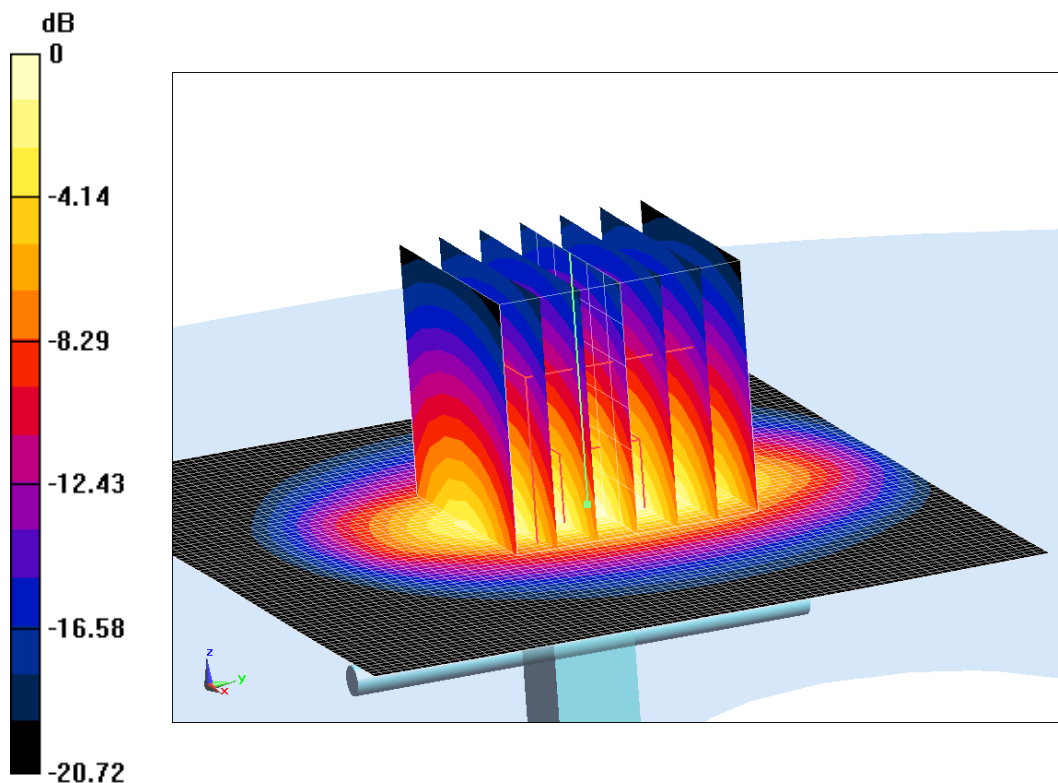

0 dB = 19.67 W/kg = 12.94 dB W/kg

**Fig.B.5 validation 2300 MHz 250mW**

**2450 MHz**

Date: 2/18/2021

Electronics: DAE4 Sn536

Medium: Head 2450 MHz

Medium parameters used:  $f = 2450 \text{ MHz}$ ;  $\sigma = 1.796 \text{ mho/m}$ ;  $\epsilon_r = 39.2$ ;  $\rho = 1000 \text{ kg/m}^3$

Ambient Temperature:  $22.5^\circ\text{C}$  Liquid Temperature:  $22.3^\circ\text{C}$

Communication System: CW Frequency: 2450 MHz Duty Cycle: 1:1

Probe: EX3DV4 – SN7307 ConvF(7.77,7.77,7.77)

**System Validation /Area Scan (81x191x1):** Interpolated grid:  $dx=1.000 \text{ mm}$ ,  $dy=1.000 \text{ mm}$

Reference Value = 120.3 V/m; Power Drift = 0.02

**Fast SAR: SAR(1 g) = 12.96 W/kg; SAR(10 g) = 6.01 W/kg**

Maximum value of SAR (interpolated) = 21.33 W/kg

**System Validation /Zoom Scan (7x7x7)/Cube 0:** Measurement grid:  $dx=5\text{mm}$ ,  $dy=5\text{mm}$ ,  $dz=5\text{mm}$

Reference Value =120.3 V/m; Power Drift = 0.02 dB

Peak SAR (extrapolated) = 26.32 W/kg

**SAR(1 g) = 13.08 W/kg; SAR(10 g) = 6.14 W/kg**

Maximum value of SAR (measured) = 21.4 W/kg

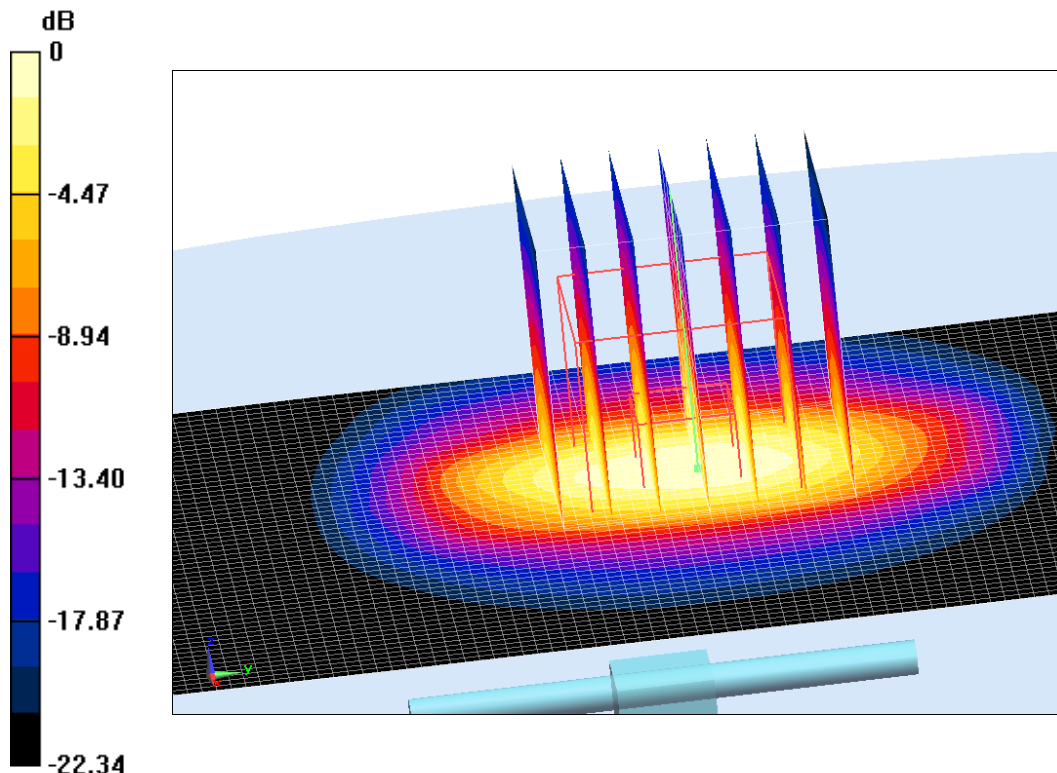

0 dB = 21.4 W/kg = 13.3 dB W/kg

**Fig.B.6 validation 2450 MHz 250mW**

**5250 MHz**

Date: 2/19/2021

Electronics: DAE4 Sn536

Medium: Head 5250 MHz

Medium parameters used:  $f = 5250 \text{ MHz}$ ;  $\sigma = 4.729 \text{ mho/m}$ ;  $\epsilon_r = 36.07$ ;  $\rho = 1000 \text{ kg/m}^3$

Ambient Temperature:  $22.5^\circ\text{C}$  Liquid Temperature:  $22.3^\circ\text{C}$

Communication System: CW Frequency: 5250 MHz Duty Cycle: 1:1

Probe: EX3DV4 – SN7307 ConvF(5.61,5.61,5.61)

**System Validation /Area Scan (81x191x1):** Interpolated grid:  $dx=1.000 \text{ mm}$ ,  $dy=1.000 \text{ mm}$

Reference Value =  $80.36 \text{ V/m}$ ; Power Drift = 0.02

**Fast SAR: SAR(1 g) =  $19.77 \text{ W/kg}$ ; SAR(10 g) =  $5.78 \text{ W/kg}$**

Maximum value of SAR (interpolated) =  $18.06 \text{ W/kg}$

**System Validation /Zoom Scan (7x7x7)/Cube 0:** Measurement grid:  $dx=5\text{mm}$ ,  $dy=5\text{mm}$ ,  $dz=5\text{mm}$

Reference Value =  $80.36 \text{ V/m}$ ; Power Drift = 0.02 dB

Peak SAR (extrapolated) =  $28.46 \text{ W/kg}$

**SAR(1 g) =  $20 \text{ W/kg}$ ; SAR(10 g) =  $5.79 \text{ W/kg}$**

Maximum value of SAR (measured) =  $18.62 \text{ W/kg}$

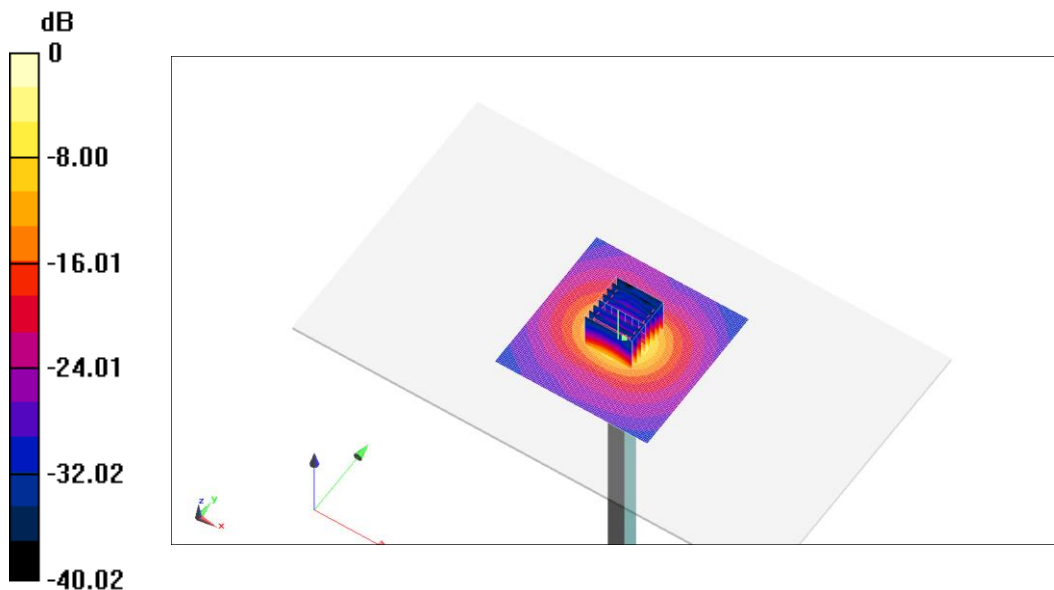

0 dB =  $18.62 \text{ W/kg}$  =  $12.7 \text{ dB W/kg}$

**Fig.B.7validation 5250 MHz 250mW**

**5600 MHz**

Date: 2/20/2021

Electronics: DAE4 Sn536

Medium: Head 5600 MHz

Medium parameters used:  $f = 5600$  MHz;  $\sigma = 5.153$  mho/m;  $\epsilon_r = 35.75$ ;  $\rho = 1000$  kg/m<sup>3</sup>

Ambient Temperature: 22.5°C Liquid Temperature: 22.3°C

Communication System: CW Frequency: 5600 MHz Duty Cycle: 1:1

Probe: EX3DV4 – SN7307 ConvF(5.1,5.1,5.1)

**System Validation /Area Scan (81x191x1):** Interpolated grid: dx=1.000 mm, dy=1.000 mm

Reference Value = 79.4 V/m; Power Drift = -0.1

**Fast SAR: SAR(1 g) = 20.89 W/kg; SAR(10 g) = 5.79 W/kg**

Maximum value of SAR (interpolated) = 19.84 W/kg

**System Validation /Zoom Scan (7x7x7)/Cube 0:** Measurement grid: dx=5mm, dy=5mm, dz=5mm

Reference Value =79.4 V/m; Power Drift = -0.1 dB

Peak SAR (extrapolated) = 31.06 W/kg

**SAR(1 g) = 20.88 W/kg; SAR(10 g) = 5.88 W/kg**

Maximum value of SAR (measured) = 20.39 W/kg

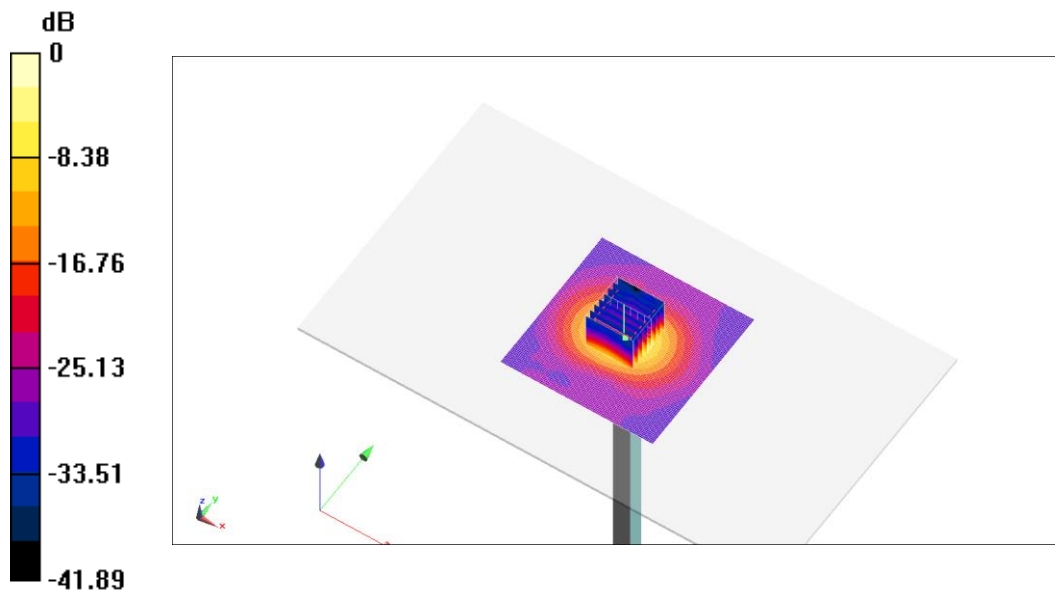

0 dB = 20.39 W/kg = 13.09 dB W/kg

**Fig.B.8 validation 5600 MHz 250mW**



**5750 MHz**

Date: 2/21/2021

Electronics: DAE4 Sn536

Medium: Head 5750 MHz

Medium parameters used:  $f = 5750 \text{ MHz}$ ;  $\sigma = 5.201 \text{ mho/m}$ ;  $\epsilon_r = 35.73$ ;  $\rho = 1000 \text{ kg/m}^3$

Ambient Temperature:  $22.5^\circ\text{C}$  Liquid Temperature:  $22.3^\circ\text{C}$

Communication System: CW Frequency:  $5750 \text{ MHz}$  Duty Cycle: 1:1

Probe: EX3DV4 – SN7307 ConvF(5.05,5.05,5.05)

**System Validation /Area Scan (81x191x1):** Interpolated grid:  $dx=1.000 \text{ mm}$ ,  $dy=1.000 \text{ mm}$

Reference Value =  $76.15 \text{ V/m}$ ; Power Drift =  $-0.02$

**Fast SAR: SAR(1 g) =  $20.29 \text{ W/kg}$ ; SAR(10 g) =  $5.74 \text{ W/kg}$**

Maximum value of SAR (interpolated) =  $20.16 \text{ W/kg}$

**System Validation /Zoom Scan (7x7x7)/Cube 0:** Measurement grid:  $dx=5\text{mm}$ ,  $dy=5\text{mm}$ ,  $dz=5\text{mm}$

Reference Value =  $76.15 \text{ V/m}$ ; Power Drift =  $-0.02 \text{ dB}$

Peak SAR (extrapolated) =  $32.38 \text{ W/kg}$

**SAR(1 g) =  $19.9 \text{ W/kg}$ ; SAR(10 g) =  $5.75 \text{ W/kg}$**

Maximum value of SAR (measured) =  $19.65 \text{ W/kg}$

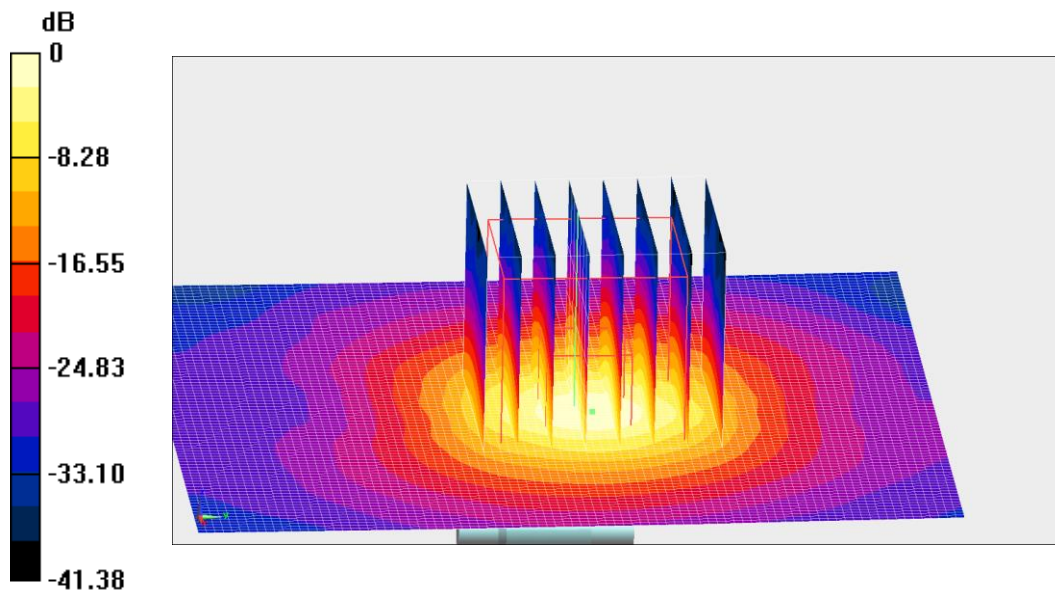

0 dB =  $19.65 \text{ W/kg}$  =  $12.93 \text{ dB W/kg}$

**Fig.B.9 validation 5750 MHz 250mW**

The SAR system verification must be required that the area scan estimated 1-g SAR is within 3% of the zoom scan 1-g SAR.

**Table B.1 Comparison between area scan and zoom scan for system verification**

<b>Date</b>	<b>Band</b>	<b>Position</b>	<b>Area scan (1g)</b>	<b>Zoom scan (1g)</b>	<b>Drift (%)</b>
2021/2/13	750 MHz	Head	2.19	2.16	1.39%
2021/2/14	835 MHz	Head	2.37	2.43	-2.47%
2021/2/15	1750 MHz	Head	9.29	9.09	2.20%
2021/2/16	1900 MHz	Head	9.84	9.94	-1.01%
2021/2/17	2300 MHz	Head	12.57	12.31	2.11%
2021/2/18	2450 MHz	Head	12.96	13.08	-0.92%

## ANNEX C SAR Measurement Setup

### C.1 Measurement Set-up

The Dasy4 or DASY5 system for performing compliance tests is illustrated above graphically. This system consists of the following items:

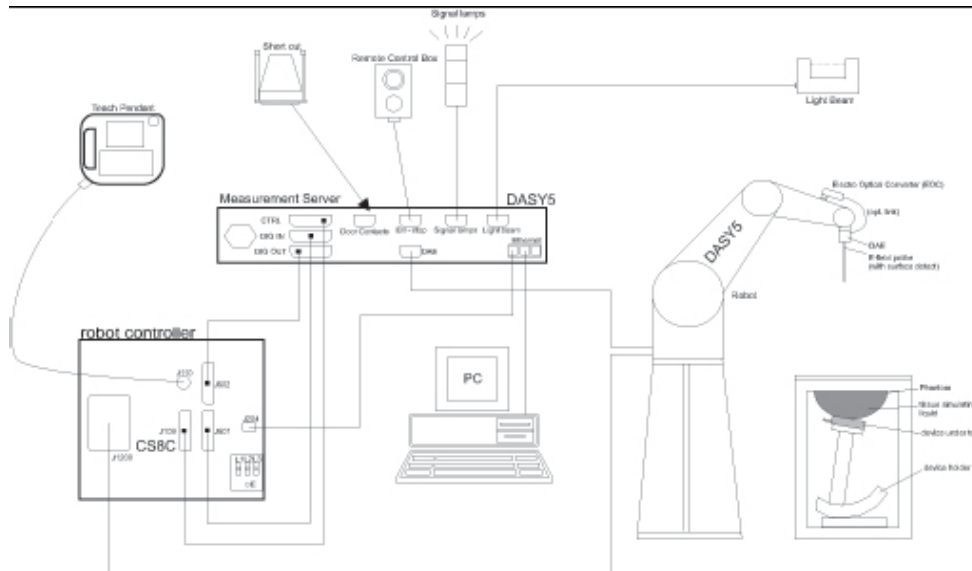

**Picture C.1 SAR Lab Test Measurement Set-up**

- A standard high precision 6-axis robot (StäubliTX=RX family) with controller, teach pendant and software. An arm extension for accommodating the data acquisition electronics (DAE).
- An isotropic field probe optimized and calibrated for the targeted measurement.
- A data acquisition electronics (DAE) which performs the signal amplification, signal multiplexing, AD-conversion, offset measurements, mechanical surface detection, collision detection, etc. The unit is battery powered with standard or rechargeable batteries. The signal is optically transmitted to the EOC.
- The Electro-optical converter (EOC) performs the conversion from optical to electrical signals for the digital communication to the DAE. To use optical surface detection, a special version of the EOC is required. The EOC signal is transmitted to the measurement server.
- The function of the measurement server is to perform the time critical tasks such as signal filtering, control of the robot operation and fast movement interrupts.
- The Light Beam used is for probe alignment. This improves the (absolute) accuracy of the probe positioning.
- A computer running WinXP and the DASY4 or DASY5 software.
- Remote control and teach pendant as well as additional circuitry for robot safety such as
- warning lamps, etc.
- The phantom, the device holder and other accessories according to the targeted measurement.

## C.2 Dasy4 or DASY5 E-field Probe System

The SAR measurements were conducted with the dosimetric probe designed in the classical triangular configuration and optimized for dosimetric evaluation. The probe is constructed using the thick film technique; with printed resistive lines on ceramic substrates. The probe is equipped with an optical multifiber line ending at the front of the probe tip. It is connected to the EOC box on the robot arm and provides an automatic detection of the phantom surface. Half of the fibers are connected to a pulsed infrared transmitter, the other half to a synchronized receiver. As the probe approaches the surface, the reflection from the surface produces a coupling from the transmitting to the receiving fibers. This reflection increases first during the approach, reaches maximum and then decreases. If the probe is flatly touching the surface, the coupling is zero. The distance of the coupling maximum to the surface is independent of the surface reflectivity and largely independent of the surface to probe angle. The DASY4 or DASY5 software reads the reflection during a software approach and looks for the maximum using 2<sup>nd</sup> ord curve fitting. The approach is stopped at reaching the maximum.

### Probe Specifications:

<b>Model:</b>	ES3DV3, EX3DV4
<b>Frequency</b>	10MHz — 6.0GHz(EX3DV4)
<b>Range:</b>	10MHz — 4GHz(ES3DV3)
<b>Calibration:</b>	In head and body simulating tissue at Frequencies from 835 up to 5800MHz
<b>Linearity:</b>	± 0.2 dB(30 MHz to 6 GHz) for EX3DV4 ± 0.2 dB(30 MHz to 4 GHz) for ES3DV3
<b>DynamicRange:</b>	10 mW/kg — 100W/kg
<b>Probe Length:</b>	330 mm
<b>Probe Tip</b>	
<b>Length:</b>	20 mm
<b>Body Diameter:</b>	12 mm
<b>Tip Diameter:</b>	2.5 mm (3.9 mm for ES3DV3)
<b>Tip-Center:</b>	1 mm (2.0mm for ES3DV3)
<b>Application:</b>	SAR Dosimetry Testing Compliance tests of mobile phones Dosimetry in strong gradient fields



Picture C.2Near-field Probe



Picture C.3E-field Probe

## C.3 E-field Probe Calibration

Each E-Probe/Probe Amplifier combination has unique calibration parameters. A TEM cell calibration procedure is conducted to determine the proper amplifier settings to enter in the probe parameters. The amplifier settings are determined for a given frequency by subjecting the probe to a known E-field density (1 mW/cm<sup>2</sup>) using an RF Signal generator, TEM cell, and RF Power Meter.

The free space E-field from amplified probe outputs is determined in a test chamber. This calibration can be performed in a TEM cell if the frequency is below 1 GHz and in a waveguide or

other methodologies above 1 GHz for free space. For the free space calibration, the probe is placed in the volumetric center of the cavity and at the proper orientation with the field. The probe is then rotated 360 degrees until the three channels show the maximum reading. The power density readings equates to 1 mW/cm<sup>2</sup>.

E-field temperature correlation calibration is performed in a flat phantom filled with the appropriate simulated brain tissue. The E-field in the medium correlates with the temperature rise in the dielectric medium. For temperature correlation calibration a RF transparent thermistor-based temperature probe is used in conjunction with the E-field probe.

$$SAR = C \frac{\Delta T}{\Delta t}$$

Where:

$\Delta t$  = Exposure time (30 seconds),

C = Heat capacity of tissue (brain or muscle),

$\Delta T$  = Temperature increase due to RF exposure.

$$SAR = \frac{|E|^2 \cdot \sigma}{\rho}$$

Where:

$\sigma$  = Simulated tissue conductivity,

$\rho$  = Tissue density (kg/m<sup>3</sup>).

## C.4 Other Test Equipment

### C.4.1 Data Acquisition Electronics(DAE)

The data acquisition electronics consist of a highly sensitive electrometer-grade preamplifier with auto-zeroing, a channel and gain-switching multiplexer, a fast 16 bit AD-converter and a command decoder with a control logic unit. Transmission to the measurement server is accomplished through an optical downlink for data and status information, as well as an optical uplink for commands and the clock.

The mechanical probe mounting device includes two different sensor systems for frontal and sideways probe contacts. They are used for mechanical surface detection and probe collision detection.

The input impedance of the DAE is 200 MOhm; the inputs are symmetrical and floating. Common mode rejection is above 80 dB.



PictureC.4: DAE

### C.4.2 Robot

The SPEAG DASY system uses the high precision robots (DASY4: RX90XL; DASY5: RX160L) type from Stäubli SA (France). For the 6-axis controller system, the robot controller version from Stäubli is used. The Stäubli robot series have many features that are important for our application:

- High precision (repeatability 0.02mm)
- High reliability (industrial design)
- Low maintenance costs (virtually maintenance free due to direct drive gears; no belt drives)
- Jerk-free straight movements (brushless synchron motors; no stepper motors)
- Low ELF interference (motor control fields shielded via the closed metallic construction shields)



Picture C.5 DASY 4



Picture C.6 DASY 5

### C.4.3 Measurement Server

The Measurement server is based on a PC/104 CPU board with CPU (dasy4: 166 MHz, Intel Pentium; DASY5: 400 MHz, Intel Celeron), chipdisk (DASY4: 32 MB; DASY5: 128MB), RAM (DASY4: 64 MB, DASY5: 128MB). The necessary circuits for communication with the DAE electronic box, as well as the 16 bit AD converter system for optical detection and digital I/O interface are contained on the DASY I/O board, which is directly connected to the PC/104 bus of the CPU board.

The measurement server performs all real-time data evaluation of field measurements and surface detection, controls robot movements and handles safety operation. The PC operating system cannot interfere with these time critical processes. All connections are supervised by a watchdog, and disconnection of any of the cables to the measurement server will automatically disarm the robot and disable all program-controlled robot movements. Furthermore, the measurement server is equipped with an expansion port which is reserved for future applications. Please note that this expansion port does not have a standardized pinout, and therefore only devices provided by SPEAG can be connected. Devices from any other supplier could seriously damage the measurement server.



Picture C.7 Server for DASY 4



Picture C.8 Server for DASY 5

#### C.4.4 Device Holder for Phantom

The SAR in the phantom is approximately inversely proportional to the square of the distance between the source and the liquid surface. For a source at 5mm distance, a positioning uncertainty of  $\pm 0.5\text{mm}$  would produce a SAR uncertainty of  $\pm 20\%$ . Accurate device positioning is therefore crucial for accurate and repeatable measurements. The positions in which the devices must be measured are defined by the standards.

The DASY device holder is designed to cope with the different positions given in the standard. It has two scales for device rotation (with respect to the body axis) and device inclination (with respect to the line between the ear reference points). The rotation centers for both scales are the ear reference point (ERP). Thus the device needs no repositioning when changing the angles. The DASY device holder is constructed of low-loss POM material having the following dielectric parameters: relative permittivity  $\epsilon = 3$  and loss tangent  $\delta = 0.02$ . The amount of dielectric material has been reduced in the closest vicinity of the device, since measurements have suggested that the influence of the clamp on the test results could thus be lowered.

<Laptop Extension Kit>

The extension is lightweight and made of POM, acrylic glass and foam. It fits easily on the upper part of the Mounting Device in place of the phone positioner. The extension is fully compatible with the Twin-SAM and ELI phantoms.



Picture C.9-1: Device Holder

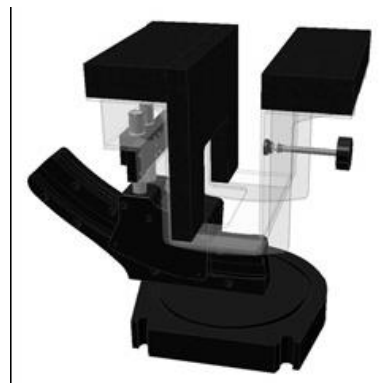

Picture C.9-2: Laptop Extension Kit

### C.4.5 Phantom

The SAM Twin Phantom V4.0 is constructed of a fiberglass shell integrated in a table. The shape of the shell is based on data from an anatomical study designed to

Represent the 90<sup>th</sup> percentile of the population. The phantom enables the dissymmetric evaluation of SAR for both left and right handed handset usage, as well as body-worn usage using the flat phantom region. Reference markings on the Phantom allow the complete setup of all predefined phantom positions and measurement grids by manually teaching three points in the robot. The shell phantom has a 2mm shell thickness (except the ear region where shell thickness increases to 6 mm).

Shell Thickness:  $2 \pm 0.2$  mm

Filling Volume: Approx. 25 liters

Dimensions: 810 x 1000 x 500 mm (H x L x W)

Available: Special



**Picture C.10: SAM Twin Phantom**



## ANNEX D Position of the wireless device in relation to the phantom

### D.1 Body-worn device

A typical example of a body-worn device is a mobile phone, wireless enabled PDA or other battery operated wireless device with the ability to transmit while mounted on a person's body using a carry accessory approved by the wireless device manufacturer.

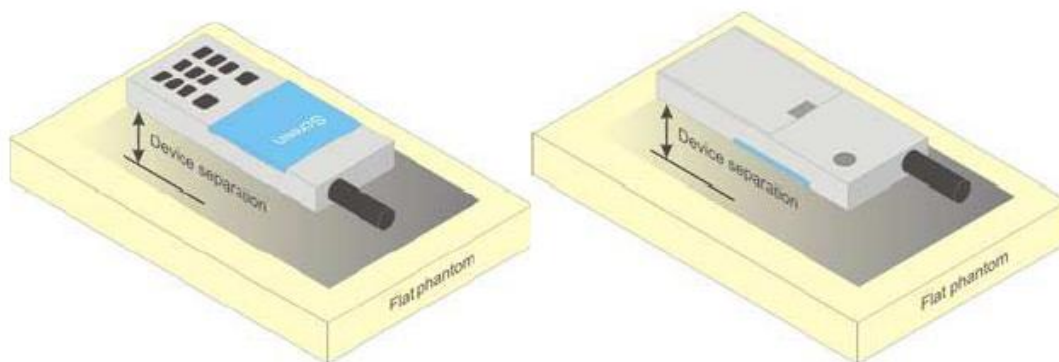

Picture D.4 Test positions for body-worn devices

### D.2 Desktop device

A typical example of a desktop device is a wireless enabled desktop computer placed on a table or desk when used.

The DUT shall be positioned at the distance and in the orientation to the phantom that corresponds to the intended use as specified by the manufacturer in the user instructions. For devices that employ an external antenna with variable positions, tests shall be performed for all antenna positions specified. Picture 8.5 show positions for desktop device SAR tests. If the intended use is not specified, the device shall be tested directly against the flat phantom.

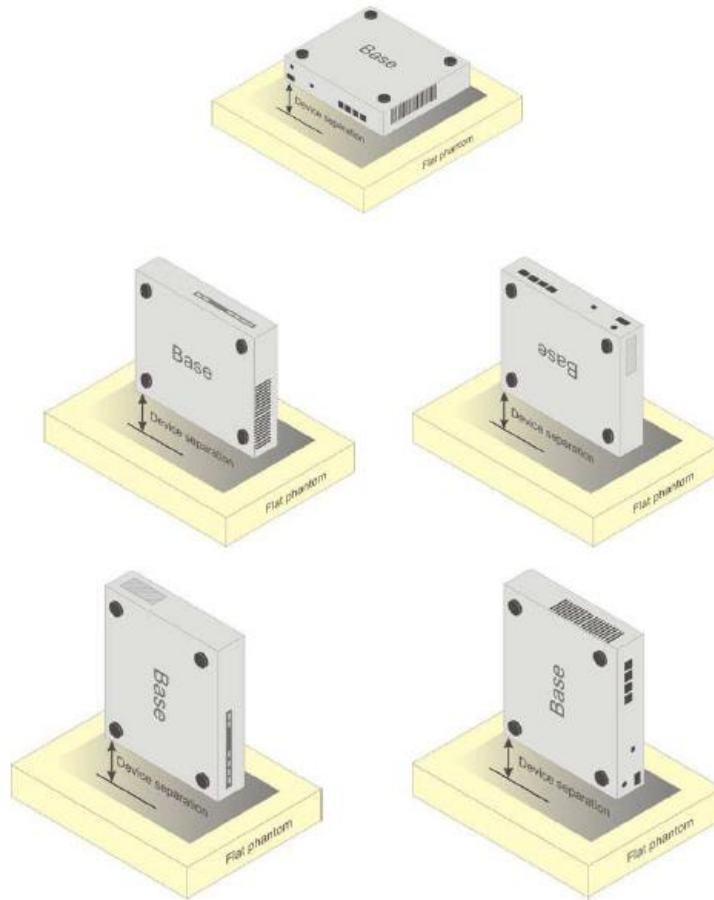

Picture D.5 Test positions for desktop devices

### D.3 DUT Setup Photos



Picture D.6

## ANNEX E Equivalent Media Recipes

The liquid used for the frequency range of 800-3000 MHz consisted of water, sugar, salt, preventol, glycol monobutyl and Cellulose. The liquid has been previously proven to be suited for worst-case. The Table E.1 shows the detail solution. It's satisfying the latest tissue dielectric parameters requirements proposed by the IEEE 1528 and IEC 62209.

**TableE.1: Composition of the Tissue Equivalent Matter**

Frequency (MHz)	835Head	835Body	1900 Head	1900 Body	2450 Head	2450 Body	5800 Head	5800 Body
Ingredients (% by weight)								
Water	41.45	52.5	55.242	69.91	58.79	72.60	65.53	65.53
Sugar	56.0	45.0	\	\	\	\	\	\
Salt	1.45	1.4	0.306	0.13	0.06	0.18	\	\
Preventol	0.1	0.1	\	\	\	\	\	\
Cellulose	1.0	1.0	\	\	\	\	\	\
Glycol Monobutyl	\	\	44.452	29.96	41.15	27.22	\	\
Diethylenglycol monohexylether	\	\	\	\	\	\	17.24	17.24
Triton X-100	\	\	\	\	\	\	17.24	17.24
Dielectric Parameters Target Value	$\epsilon=41.5$ $\sigma=0.90$	$\epsilon=55.2$ $\sigma=0.97$	$\epsilon=40.0$ $\sigma=1.40$	$\epsilon=53.3$ $\sigma=1.52$	$\epsilon=39.2$ $\sigma=1.80$	$\epsilon=52.7$ $\sigma=1.95$	$\epsilon=35.3$ $\sigma=5.27$	$\epsilon=48.2$ $\sigma=6.00$

**Note: There are a little adjustment respectively for 750, 1750, 2600, 5200, 5300 and 5600 based on the recipe of closest frequency in table E.1.**

## ANNEX F System Validation

The SAR system must be validated against its performance specifications before it is deployed. When SAR probes, system components or software are changed, upgraded or recalibrated, these must be validated with the SAR system(s) that operates with such components.

**Table F.1: System Validation for 7307**

Probe SN.	Liquid name	Validation date	Frequency point	Status (OK or Not)
7307	Head 750MHz	June.15,2020	750 MHz	OK
7307	Head 850MHz	June.15,2020	835 MHz	OK
7307	Head 900MHz	June.15,2020	900 MHz	OK
7307	Head 1750MHz	June.15,2020	1750 MHz	OK
7307	Head 1810MHz	June.15,2020	1810 MHz	OK
7307	Head 1900MHz	June.16,2020	1900 MHz	OK
7307	Head 2000MHz	June.16,2020	2000 MHz	OK
7307	Head 2100MHz	June.16,2020	2100 MHz	OK
7307	Head 2300MHz	June.16,2020	2300 MHz	OK
7307	Head 2450MHz	June.16,2020	2450 MHz	OK
7307	Head 2600MHz	June.17,2020	2600 MHz	OK
7307	Head 3500MHz	June.17,2020	3500 MHz	OK
7307	Head 3700MHz	June.17,2020	3700 MHz	OK
7307	Head 5200MHz	June.17,2020	5250 MHz	OK
7307	Head 5500MHz	June.17,2020	5600 MHz	OK
7307	Head 5800MHz	June.17,2020	5800 MHz	OK
7307	Body 750MHz	June.17,2020	750 MHz	OK
7307	Body 850MHz	June.18,2020	835 MHz	OK
7307	Body 900MHz	June.18,2020	900 MHz	OK
7307	Body 1750MHz	June.18,2020	1750 MHz	OK
7307	Body 1810MHz	June.18,2020	1810 MHz	OK
7307	Body 1900MHz	June.18,2020	1900 MHz	OK
7307	Body 2000MHz	June.19,2020	2000 MHz	OK
7307	Body 2100MHz	June.19,2020	2100 MHz	OK
7307	Body 2300MHz	June.19,2020	2300 MHz	OK
7307	Body 2450MHz	June.19,2020	2450 MHz	OK
7307	Body 2600MHz	June.19,2020	2600 MHz	OK
7307	Body 3500MHz	June.20,2020	3500 MHz	OK
7307	Body 3700MHz	June.20,2020	3700 MHz	OK
7307	Body 5200MHz	June.20,2020	5250 MHz	OK
7307	Body 5500MHz	June.20,2020	5600 MHz	OK
7307	Body 5800MHz	June.20,2020	5800 MHz	OK

## ANNEX G Sensor Triggering Data Summary

### Main and Wifi Antenna

SAR Sensor	Left(mm)	20(mm)
SAR Sensor	Front(mm)	18(mm)
SAR Sensor	Back(mm)	18(mm)

According to the above description, this device was tested by the manufacturer to determine the SAR sensor triggering distances for the front, rear, and left edge both for main and WIFI antenna. The measured power state within  $\pm 5$ mm of the triggering points (or until touching the phantom) is included for front, rear and Left edge.

To ensure all production units are compliant it is necessary to test SAR at a distance 1mm less than the smallest distance from the device and SAR phantom with the device at maximum output power without power reduction.

We tested the power and got the different proximity sensor triggering distances for front, rear and left edge. But the manufacturer has declared 18mm (rear) / 18mm (front) / 20mm (left) are the most conservative triggering distance for wifi and main antenna. Therefore base on the most conservative triggering distances as above, additional SAR measurements were required at 17mm (rear) / 17mm (front) / 19mm (left) for main antenna and wifi antenna.

### WWAN Antenna:

#### Rear

Moving device toward the phantom:

Distance [mm]	The power state																		
	32	31	30	29	28	27	26	25	24	23	22	19	16	13	10	7	4	1	0
Conducted power(dBm)	23.1	23.09	23.13	23.05	23.04	20.81	20.79	20.76	20.83	20.82	20.82	20.8	20.82	20.78	20.8	20.82	20.81	20.76	20.8

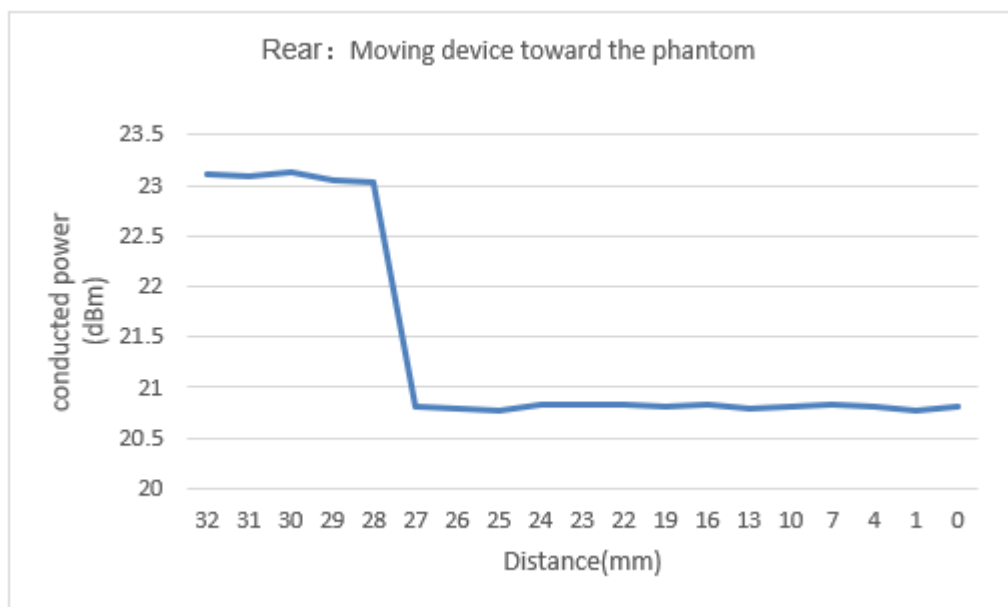

Moving device away from the phantom:

		The power state																		
Distance [mm]	8	13	18	22	23	24	25	26	27	28	29	30	31	32	35	38	41	44	47	50
Conducted power(dBm)	20.81	20.83	20.79	20.79	20.81	20.82	20.8	20.78	20.81	23.01	23.02	23.06	23.02	23.05	23.04	23.06	23.07	23.08	23.01	23.01

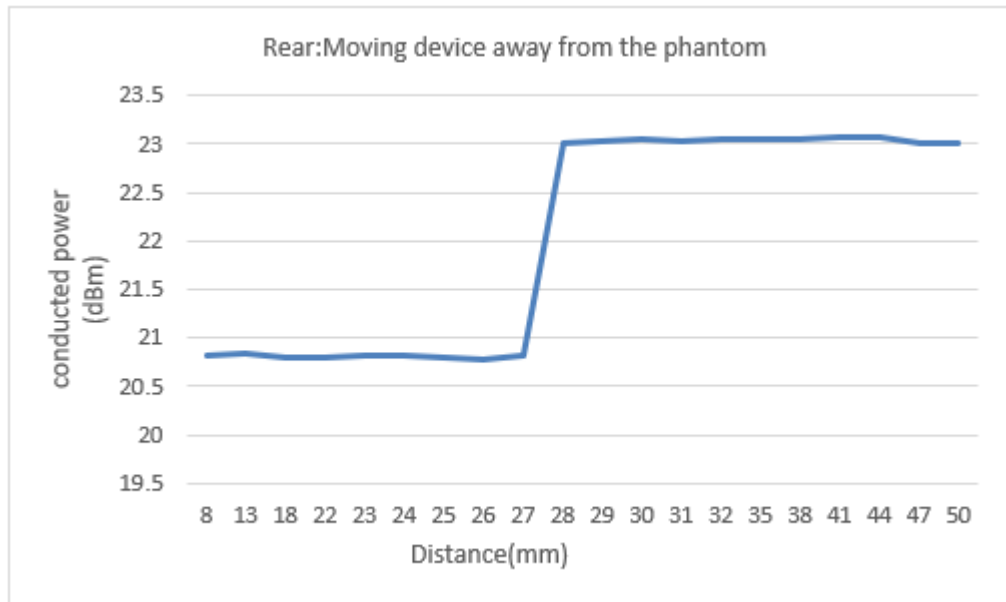

**Front**

Moving device toward the phantom:

		The power state																	
Distance [mm]	32	31	30	29	28	27	26	25	24	23	22	19	16	13	10	7	4	1	0
Conducted power(dBm)	23.06	23.11	23.08	23.07	23.04	20.79	20.75	20.76	20.77	20.78	20.81	20.76	20.73	20.75	20.71	20.77	20.79	20.74	20.73

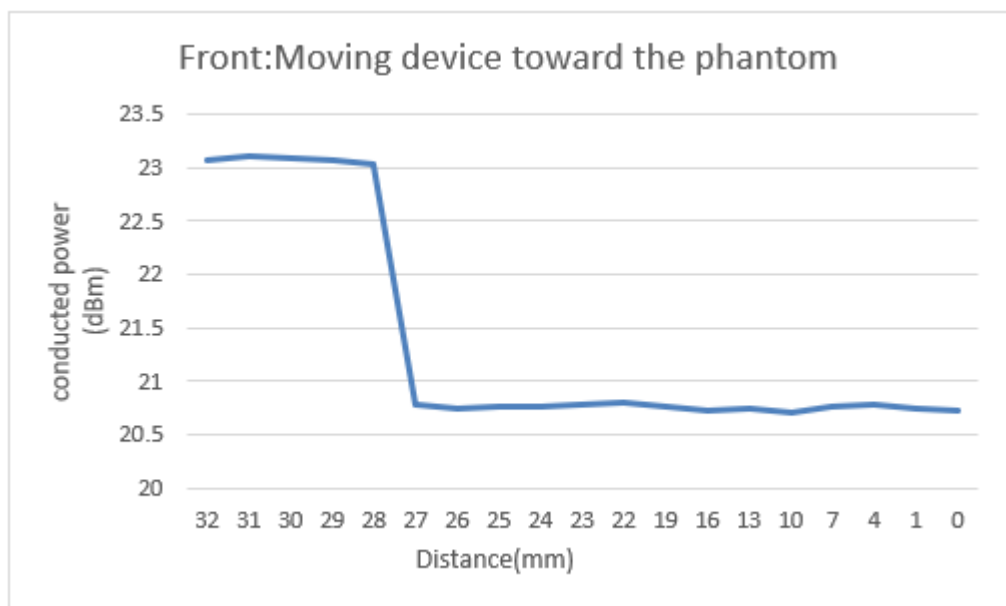

Moving device away from the phantom:

Distance [mm]	The power state																			
	8	13	18	22	23	24	25	26	27	28	29	30	31	32	35	38	41	44	47	50
Conducted power(dBm)	20.79	20.81	20.78	20.76	20.8	20.81	20.79	20.78	20.77	23.05	23.03	23.08	23.01	23.03	23.07	23.09	23.06	23.03	23.05	23.06

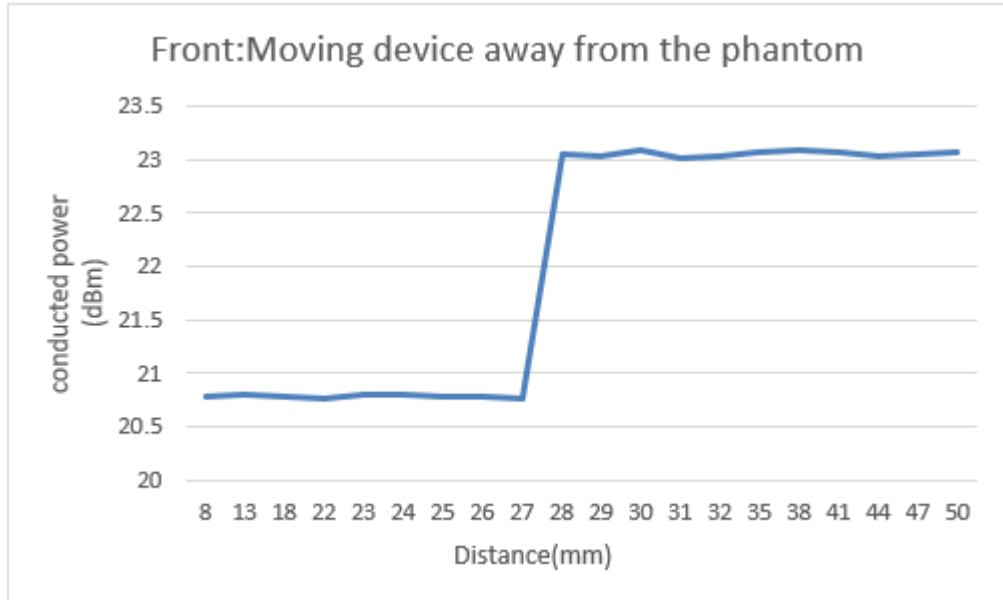

**Left Edge**

Moving device toward the phantom:

Distance [mm]	The power state																			
	37	36	35	34	33	32	31	30	29	28	27	24	21	18	15	12	9	6	3	0
Conducted power(dBm)	23.07	23.06	23.05	23.07	23.05	20.79	20.76	20.81	20.81	20.79	20.76	20.79	20.81	20.82	20.81	20.78	20.76	20.82	20.78	20.8

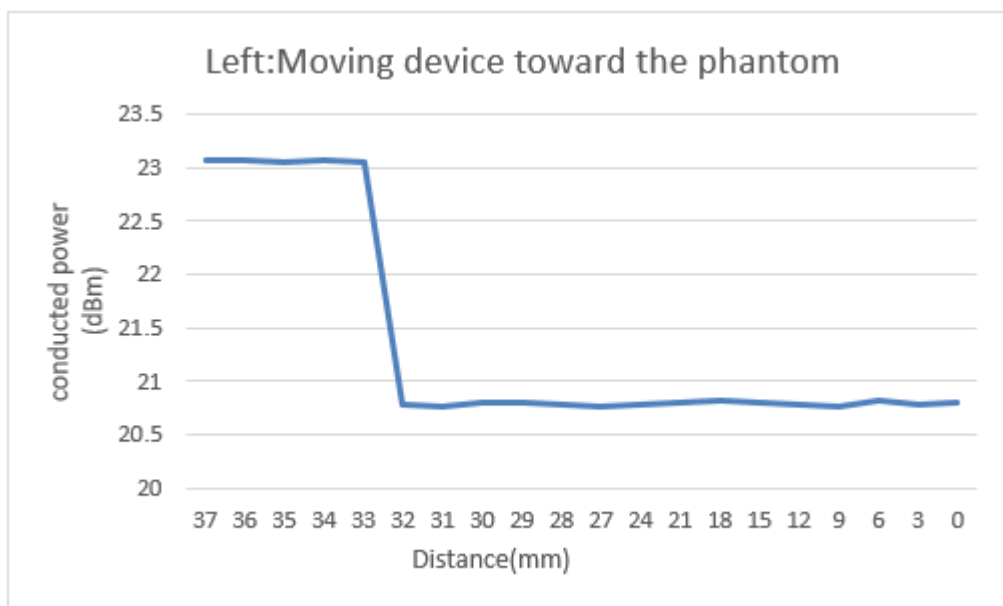

Moving device away from the phantom:

		The power state																			
Distance [mm]		10	15	20	25	27	28	29	30	31	32	33	34	35	36	37	40	43	46	49	50
Conducted power(dBm)		20.83	20.79	20.78	20.81	20.82	20.82	20.79	20.78	20.81	20.82	23.06	23.07	23.05	23.07	23.06	23.03	23.08	23.06	23.01	23.06

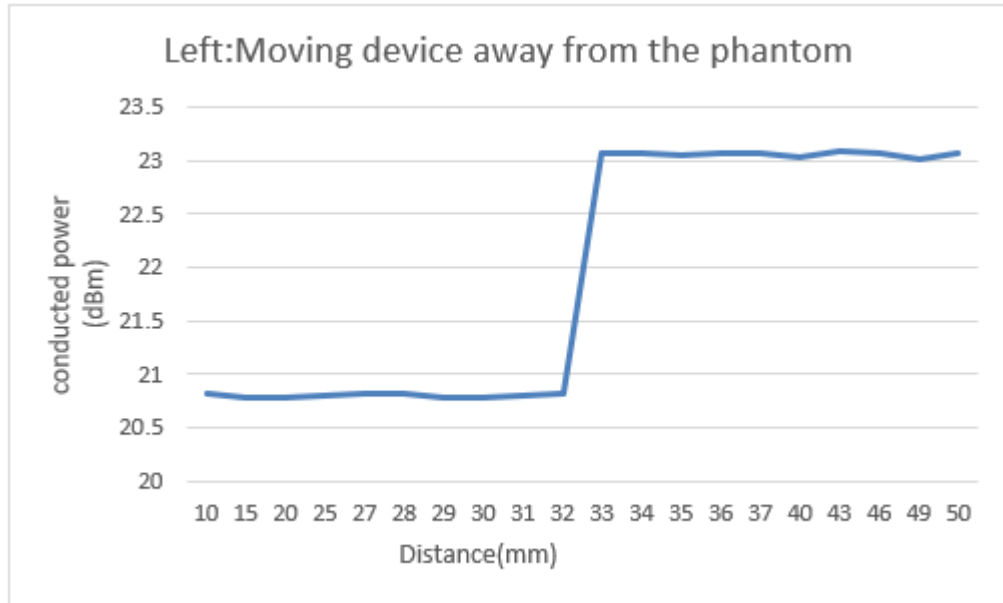

**WLAN Antenna:**

**Rear**

Moving device toward the phantom:

		The power state																		
Distance [mm]		32	31	30	29	28	27	26	25	24	23	22	19	16	13	10	7	4	1	0
Conducted power(dBm)		16.34	16.35	16.32	16.29	16.31	13.57	13.58	13.56	13.57	13.58	13.56	13.59	13.57	13.56	13.57	13.58	13.55	13.56	13.55

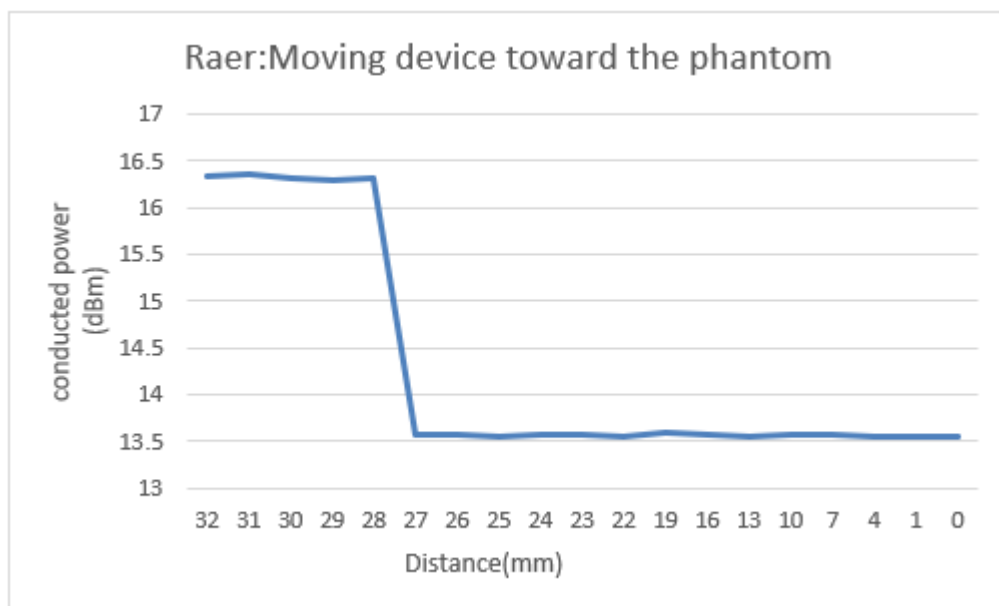



Moving device away from the phantom:

	The power state																			
Distance [mm]	8	13	18	22	23	24	25	26	27	28	29	30	31	32	35	38	41	44	47	50
Conducted power(dBm)	13.58	13.61	13.62	13.61	13.59	13.63	13.65	13.61	13.62	16.27	16.26	16.21	16.23	16.28	16.3	16.26	16.28	16.26	16.25	16.27

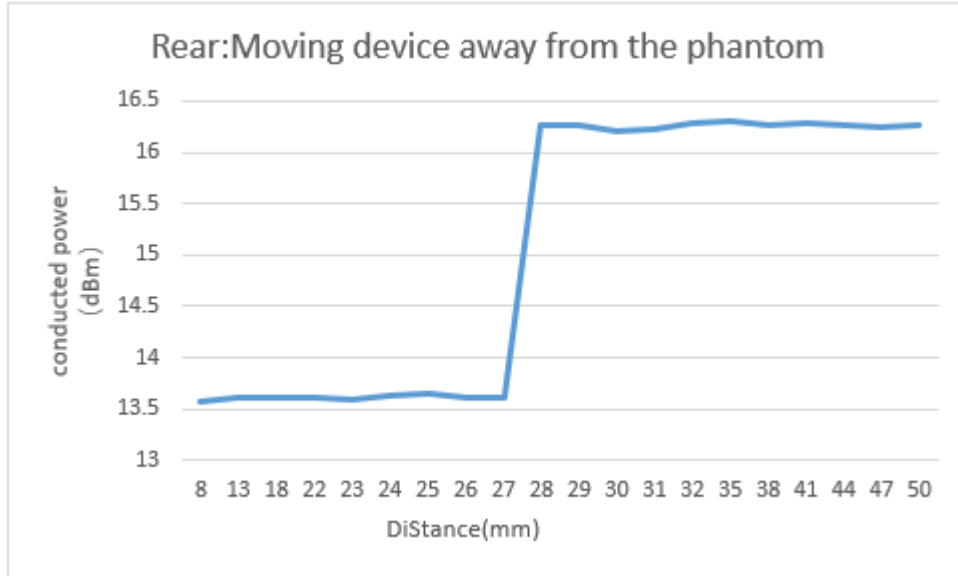

**Front**

Moving device toward the phantom:

	The power state																			
Distance [mm]	32	31	30	29	28	27	26	25	24	23	22	19	16	13	10	7	4	1	0	
Conducted power(dBm)	16.3	16.32	16.31	16.35	16.31	13.68	13.66	13.66	13.65	13.63	13.62	13.63	13.65	13.61	13.62	13.63	13.64	13.62	13.63	

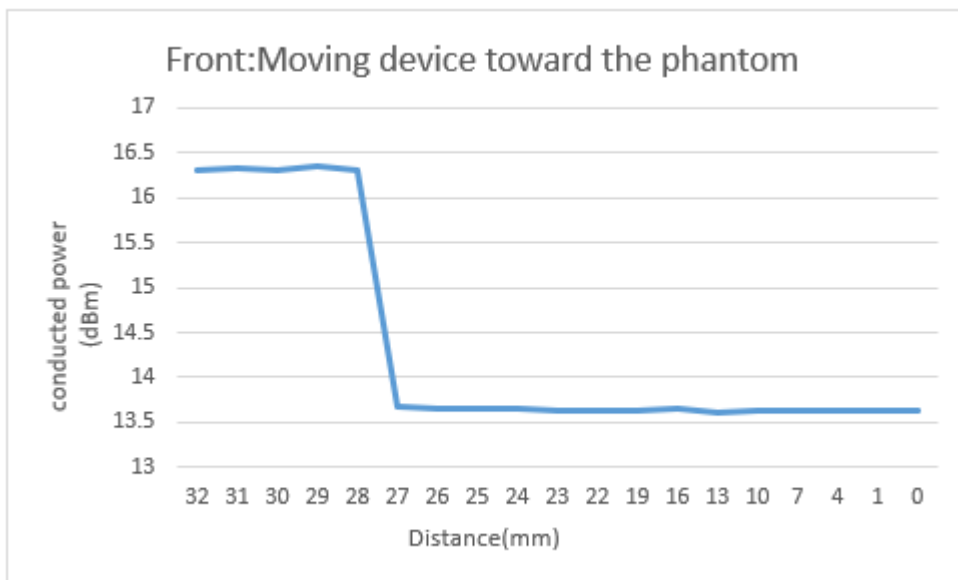

Moving device away from the phantom:

Distance [mm]	The power state																			
	8	13	18	22	23	24	25	26	27	28	29	30	31	32	35	38	41	44	47	50
Conducted power(dBm)	13.68	13.66	13.68	13.62	13.66	13.63	13.61	13.63	13.65	16.3	16.35	16.31	16.32	16.36	16.35	16.34	16.31	16.31	16.35	16.33

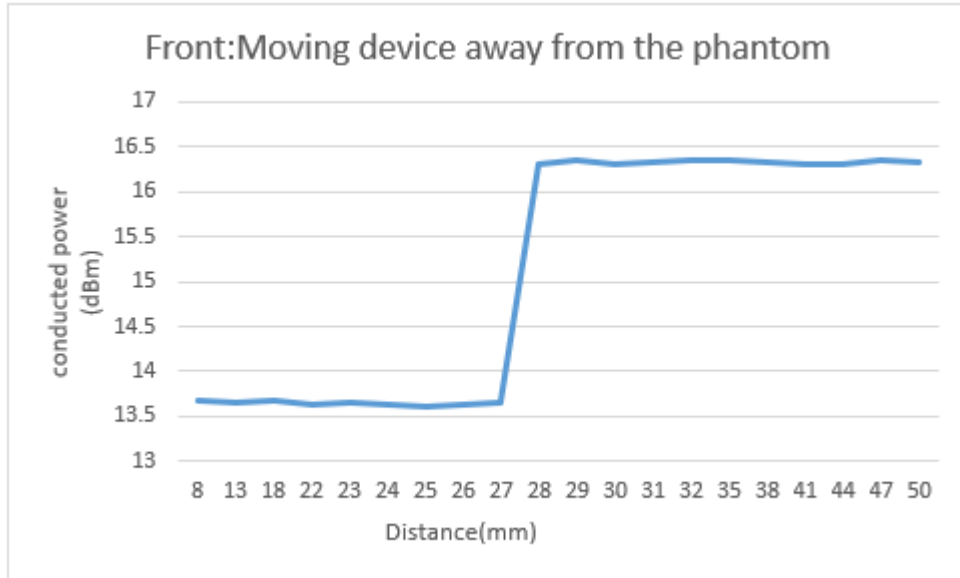

**Left:**

Moving device toward the phantom:

Distance [mm]	The power state																			
	37	36	35	34	33	32	31	30	29	28	27	24	21	18	15	12	9	6	3	0
Conducted power(dBm)	16.37	16.38	16.33	16.31	16.33	13.53	13.58	13.59	13.56	13.56	13.58	13.53	13.59	13.58	13.55	13.53	13.59	13.6	13.58	13.59

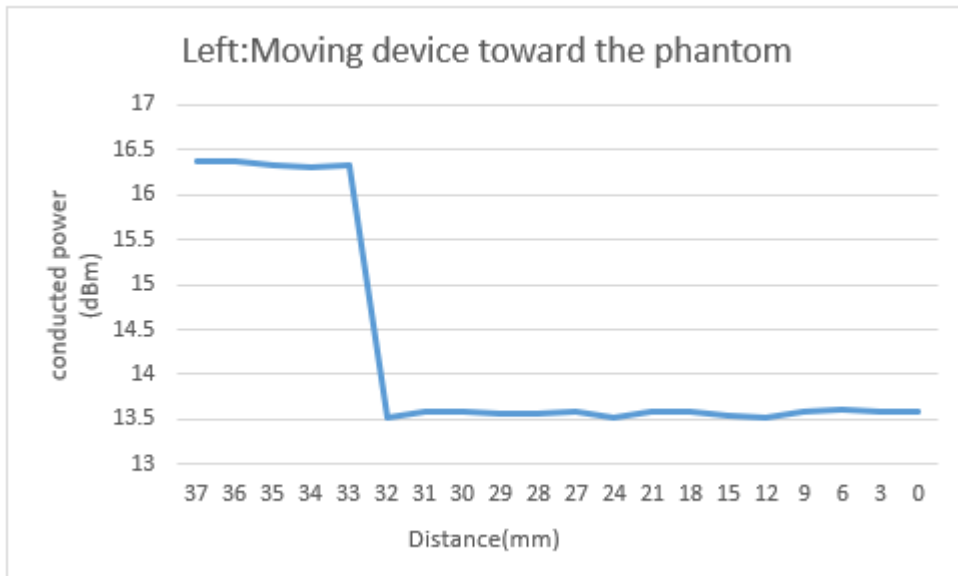

Moving device away from the phantom:

Distance [mm]	10	15	20	25	27	28	29	30	31	32	33	34	35	36	37	40	43	46	49	50
Conducted power(dBm)	13.51	13.53	13.53	13.56	13.54	13.57	13.58	13.54	13.56	13.55	16.31	16.32	16.36	16.32	16.37	16.38	16.36	16.32	16.36	16.33

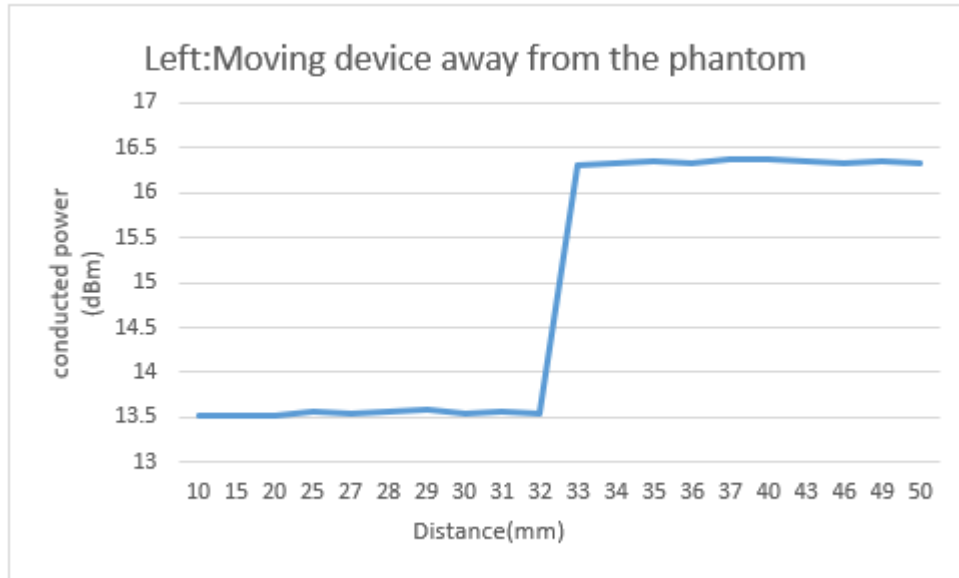

Note: The trigger distance declared by the customer is smaller than the corresponding actual trigger distance, so the distance for SAR test is conservative.

The influence of table tilt angles to proximity sensor triggering is determined by positioning each edge that contains a transmitting antenna, perpendicular to the flat phantom, at the smallest sensor triggering test distance by rotating the device around the edge next to the phantom in  $\leq 10^\circ$  increments until the tablet is  $\pm 45^\circ$  or more from the vertical position at  $0^\circ$ .

