

Impedance Measurement Plot

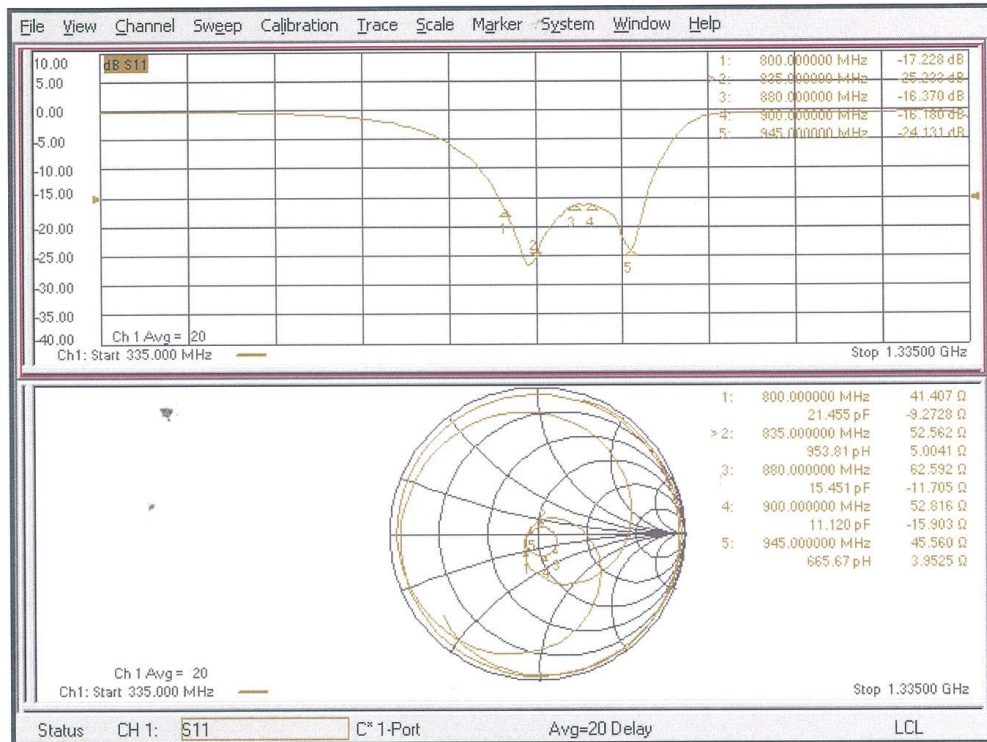

DASY5 E-field Result

Date: 26.08.2019

Test Laboratory: SPEAG Lab2

DUT: HAC-Dipole 835 MHz; Type: CD835V3; Serial: CD835V3 - SN: 1023

Communication System: UID 0 - CW ; Frequency: 835 MHz
 Medium parameters used: $\sigma = 0$ S/m, $\epsilon_r = 1$; $\rho = 0$ kg/m³
 Phantom section: RF Section
 Measurement Standard: DASY5 (IEEE/IEC/ANSI C63.19-2011)

DASY52 Configuration:

- Probe: EF3DV3 - SN4013; ConvF(1, 1, 1) @ 835 MHz; Calibrated: 03.01.2019
- Sensor-Surface: (Fix Surface)
- Electronics: DAE4 Sn781; Calibrated: 09.01.2019
- Phantom: HAC Test Arch with AMCC; Type: SD HAC P01 BA; Serial: 1070
- DASY52 52.10.2(1504); SEMCAD X 14.6.12(7470)

Dipole E-Field measurement @ 835MHz/E-Scan - 835MHz d=15mm/Hearing Aid Compatibility Test (41x361x1):

Interpolated grid: dx=0.5000 mm, dy=0.5000 mm
 Device Reference Point: 0, 0, -6.3 mm
 Reference Value = 127.9 V/m; Power Drift = -0.01 dB
 Applied MIF = 0.00 dB
 RF audio interference level = 40.56 dBV/m
Emission category: M3

MIF scaled E-field

Grid 1 M3 40.08 dBV/m	Grid 2 M3 40.56 dBV/m	Grid 3 M3 40.51 dBV/m
Grid 4 M4 35.34 dBV/m	Grid 5 M4 35.68 dBV/m	Grid 6 M4 35.67 dBV/m
Grid 7 M3 40.23 dBV/m	Grid 8 M3 40.56 dBV/m	Grid 9 M3 40.49 dBV/m

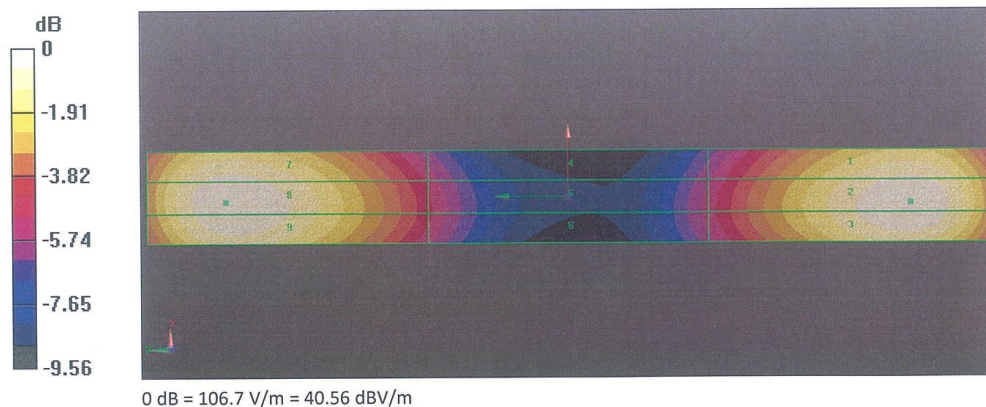

Dipole 1880 MHz

**Calibration Laboratory of
Schmid & Partner
Engineering AG**
Zeughausstrasse 43, 8004 Zurich, Switzerland



S Schweizerischer Kalibrierdienst
S Service suisse d'étalonnage
S Servizio svizzero di taratura
S Swiss Calibration Service

Accredited by the Swiss Accreditation Service (SAS)
The Swiss Accreditation Service is one of the signatories to the EA
Multilateral Agreement for the recognition of calibration certificates

Accreditation No.: **SCS 0108**

Client **CTTL (Auden)**

Certificate No: **CD1880V3-1018_Aug19**

CALIBRATION CERTIFICATE

Object **CD1880V3 - SN: 1018**

Calibration procedure(s) **QA CAL-20.v7
Calibration Procedure for Validation Sources in air**



Calibration date: **August 26, 2019**

This calibration certificate documents the traceability to national standards, which realize the physical units of measurements (SI).
The measurements and the uncertainties with confidence probability are given on the following pages and are part of the certificate.

All calibrations have been conducted in the closed laboratory facility: environment temperature (22 ± 3)°C and humidity < 70%.

Calibration Equipment used (M&TE critical for calibration)

Primary Standards	ID #	Cal Date (Certificate No.)	Scheduled Calibration
Power meter NRP	SN: 104778	03-Apr-19 (No. 217-02892/02893)	Apr-20
Power sensor NRP-Z91	SN: 103244	03-Apr-19 (No. 217-02892)	Apr-20
Power sensor NRP-Z91	SN: 103245	03-Apr-19 (No. 217-02893)	Apr-20
Reference 20 dB Attenuator	SN: 5058 (20k)	04-Apr-19 (No. 217-02894)	Apr-20
Type-N mismatch combination	SN: 5047.2 / 06327	04-Apr-19 (No. 217-02895)	Apr-20
Probe EF3DV3	SN: 4013	03-Jan-19 (No. EF3-4013_Jan19)	Jan-20
DAE4	SN: 781	09-Jan-19 (No. DAE4-781_Jan19)	Jan-20
Secondary Standards	ID #	Check Date (in house)	Scheduled Check
Power meter Agilent 4419B	SN: GB42420191	09-Oct-09 (in house check Oct-17)	In house check: Oct-20
Power sensor HP E4412A	SN: US38485102	05-Jan-10 (in house check Oct-17)	In house check: Oct-20
Power sensor HP 8482A	SN: US37295597	09-Oct-09 (in house check Oct-17)	In house check: Oct-20
RF generator R&S SMT-06	SN: 837633/005	10-Jan-19 (in house check Jan-19)	In house check: Oct-22
Network Analyzer Agilent E8358A	SN: US41080477	31-Mar-14 (in house check Oct-18)	In house check: Oct-19

	Name	Function	Signature
Calibrated by:	Leif Klysner	Laboratory Technician	
Approved by:	Katja Pokovic	Technical Manager	

Issued: August 27, 2019

This calibration certificate shall not be reproduced except in full without written approval of the laboratory.

**Calibration Laboratory of
Schmid & Partner
Engineering AG**
Zeughausstrasse 43, 8004 Zurich, Switzerland



S Schweizerischer Kalibrierdienst
C Service suisse d'étalonnage
S Servizio svizzero di taratura
S Swiss Calibration Service

Accredited by the Swiss Accreditation Service (SAS)
The Swiss Accreditation Service is one of the signatories to the EA
Multilateral Agreement for the recognition of calibration certificates

Accreditation No.: **SCS 0108**

References

- [1] ANSI-C63.19-2011
American National Standard, Methods of Measurement of Compatibility between Wireless Communications Devices and Hearing Aids.

Methods Applied and Interpretation of Parameters:

- **Coordinate System:** y-axis is in the direction of the dipole arms. z-axis is from the basis of the antenna (mounted on the table) towards its feed point between the two dipole arms. x-axis is normal to the other axes. In coincidence with the standards [1], the measurement planes (probe sensor center) are selected to be at a distance of 15 mm above the top metal edge of the dipole arms.
- **Measurement Conditions:** Further details are available from the hardcopies at the end of the certificate. All figures stated in the certificate are valid at the frequency indicated. The forward power to the dipole connector is set with a calibrated power meter connected and monitored with an auxiliary power meter connected to a directional coupler. While the dipole under test is connected, the forward power is adjusted to the same level.
- **Antenna Positioning:** The dipole is mounted on a HAC Test Arch phantom using the matching dipole positioner with the arms horizontal and the feeding cable coming from the floor. The measurements are performed in a shielded room with absorbers around the setup to reduce the reflections. It is verified before the mounting of the dipole under the Test Arch phantom, that its arms are perfectly in a line. It is installed on the HAC dipole positioner with its arms parallel below the dielectric reference wire and able to move elastically in vertical direction without changing its relative position to the top center of the Test Arch phantom. The vertical distance to the probe is adjusted after dipole mounting with a DASY5 Surface Check job. Before the measurement, the distance between phantom surface and probe tip is verified. The proper measurement distance is selected by choosing the matching section of the HAC Test Arch phantom with the proper device reference point (upper surface of the dipole) and the matching grid reference point (tip of the probe) considering the probe sensor offset. The vertical distance to the probe is essential for the accuracy.
- **Feed Point Impedance and Return Loss:** These parameters are measured using a Vector Network Analyzer. The impedance is specified at the SMA connector of the dipole. The influence of reflections was eliminated by applying the averaging function while moving the dipole in the air, at least 70cm away from any obstacles.
- **E-field distribution:** E field is measured in the x-y-plane with an isotropic E-field probe with 100 mW forward power to the antenna feed point. In accordance with [1], the scan area is 20mm wide, its length exceeds the dipole arm length (180 or 90mm). The sensor center is 15 mm (in z) above the metal top of the dipole arms. Two 3D maxima are available near the end of the dipole arms. Assuming the dipole arms are perfectly in one line, the average of these two maxima (in subgrid 2 and subgrid 8) is determined to compensate for any non-parallelity to the measurement plane as well as the sensor displacement. The E-field value stated as calibration value represents the maximum of the interpolated 3D-E-field, in the plane above the dipole surface.

The reported uncertainty of measurement is stated as the standard uncertainty of measurement multiplied by the coverage factor $k=2$, which for a normal distribution corresponds to a coverage probability of approximately 95%.

Measurement Conditions

DASY system configuration, as far as not given on page 1.

DASY Version	DASY5	V52.10.2
Phantom	HAC Test Arch	
Distance Dipole Top - Probe Center	15 mm	
Scan resolution	dx, dy = 5 mm	
Frequency	1880 MHz ± 1 MHz	
Input power drift	< 0.05 dB	

Maximum Field values at 1880 MHz

E-field 15 mm above dipole surface	condition	Interpolated maximum
Maximum measured above high end	100 mW input power	88.0 V/m = 38.89 dBV/m
Maximum measured above low end	100 mW input power	86.5 V/m = 38.74 dBV/m
Averaged maximum above arm	100 mW input power	87.3 V/m ± 12.8 % (k=2)

Appendix (Additional assessments outside the scope of SCS 0108)

Antenna Parameters

Frequency	Return Loss	Impedance
1730 MHz	27.8 dB	54.3 Ω + 0.3 jΩ
1880 MHz	21.6 dB	55.4 Ω + 7.0 jΩ
1900 MHz	22.8 dB	56.3 Ω + 4.5 jΩ
1950 MHz	33.3 dB	52.2 Ω - 0.1 jΩ
2000 MHz	19.4 dB	47.6 Ω + 10.2 jΩ

3.2 Antenna Design and Handling

The calibration dipole has a symmetric geometry with a built-in two stub matching network, which leads to the enhanced bandwidth.

The dipole is built of standard semirigid coaxial cable. The internal matching line is open ended. The antenna is therefore open for DC signals.

Do not apply force to dipole arms, as they are liable to bend. The soldered connections near the feedpoint may be damaged. After excessive mechanical stress or overheating, check the impedance characteristics to ensure that the internal matching network is not affected.

After long term use with 40W radiated power, only a slight warming of the dipole near the feedpoint can be measured.

Impedance Measurement Plot

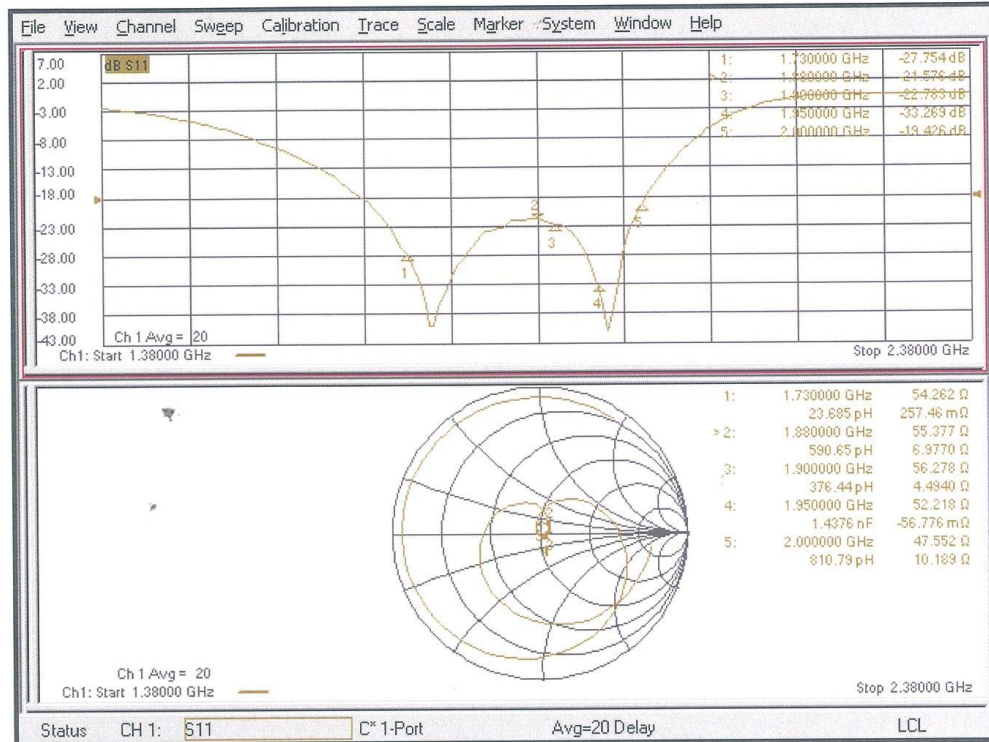

DASY5 E-field Result

Date: 26.08.2019

Test Laboratory: SPEAG Lab2

DUT: HAC Dipole 1880 MHz; Type: CD1880V3; Serial: CD1880V3 - SN: 1018

Communication System: UID 0 - CW ; Frequency: 1880 MHz
 Medium parameters used: $\sigma = 0$ S/m, $\epsilon_r = 1$; $\rho = 0$ kg/m³
 Phantom section: RF Section
 Measurement Standard: DASY5 (IEEE/IEC/ANSI C63.19-2011)

DASY52 Configuration:

- Probe: EF3DV3 - SN4013; ConvF(1, 1, 1) @ 1880 MHz; Calibrated: 03.01.2019
- Sensor-Surface: (Fix Surface)
- Electronics: DAE4 Sn781; Calibrated: 09.01.2019
- Phantom: HAC Test Arch with AMCC; Type: SD HAC P01 BA; Serial: 1070
- DASY52 52.10.2(1504); SEMCAD X 14.6.12(7470)

Dipole E-Field measurement @ 1880MHz/E-Scan - 1880MHz d=15mm/Hearing Aid Compatibility Test (41x181x1):
 Interpolated grid: dx=0.5000 mm, dy=0.5000 mm
 Device Reference Point: 0, 0, -6.3 mm
 Reference Value = 151.1 V/m; Power Drift = -0.01 dB
 Applied MIF = 0.00 dB
 RF audio interference level = 38.89 dBV/m
Emission category: M2

MIF scaled E-field

Grid 1 M2 38.47 dBV/m	Grid 2 M2 38.89 dBV/m	Grid 3 M2 38.86 dBV/m
Grid 4 M2 35.88 dBV/m	Grid 5 M2 36.02 dBV/m	Grid 6 M2 35.97 dBV/m
Grid 7 M2 38.51 dBV/m	Grid 8 M2 38.74 dBV/m	Grid 9 M2 38.6 dBV/m

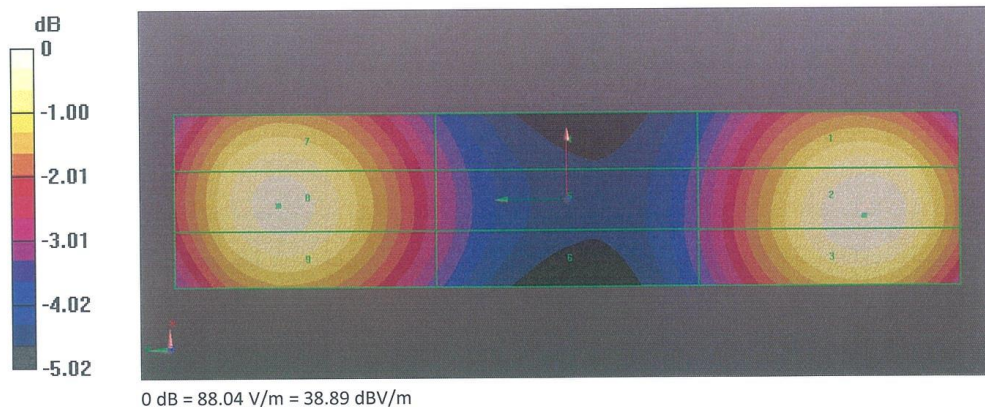

Dipole 2600 MHz

**Calibration Laboratory of
Schmid & Partner
Engineering AG**
Zeughausstrasse 43, 8004 Zurich, Switzerland



S Schweizerischer Kalibrierdienst
S Service suisse d'étalonnage
S Servizio svizzero di taratura
S Swiss Calibration Service

Accredited by the Swiss Accreditation Service (SAS)
The Swiss Accreditation Service is one of the signatories to the EA
Multilateral Agreement for the recognition of calibration certificates

Accreditation No.: **SCS 0108**

Client **CTTL (Auden)**

Certificate No: **CD2600V3-1017_Aug19**

CALIBRATION CERTIFICATE

Object **CD2600V3 - SN: 1017**

Calibration procedure(s) **QA CAL-20.v7
Calibration Procedure for Validation Sources in air**



Calibration date: **August 23, 2019**

This calibration certificate documents the traceability to national standards, which realize the physical units of measurements (SI).
The measurements and the uncertainties with confidence probability are given on the following pages and are part of the certificate.

All calibrations have been conducted in the closed laboratory facility: environment temperature (22 ± 3)°C and humidity < 70%.

Calibration Equipment used (M&TE critical for calibration)

Primary Standards	ID #	Cal Date (Certificate No.)	Scheduled Calibration
Power meter NRP	SN: 104778	03-Apr-19 (No. 217-02892/02893)	Apr-20
Power sensor NRP-Z91	SN: 103244	03-Apr-19 (No. 217-02892)	Apr-20
Power sensor NRP-Z91	SN: 103245	03-Apr-19 (No. 217-02893)	Apr-20
Reference 20 dB Attenuator	SN: 5058 (20k)	04-Apr-19 (No. 217-02894)	Apr-20
Type-N mismatch combination	SN: 5047.2 / 06327	04-Apr-19 (No. 217-02895)	Apr-20
Probe EF3DV3	SN: 4013	03-Jan-19 (No. EF3-4013_Jan19)	Jan-20
DAE4	SN: 781	09-Jan-19 (No. DAE4-781_Jan19)	Jan-20
Secondary Standards	ID #	Check Date (in house)	Scheduled Check
Power meter Agilent 4419B	SN: GB42420191	09-Oct-09 (in house check Oct-17)	In house check: Oct-20
Power sensor HP E4412A	SN: US38485102	05-Jan-10 (in house check Oct-17)	In house check: Oct-20
Power sensor HP 8482A	SN: US37295597	09-Oct-09 (in house check Oct-17)	In house check: Oct-20
RF generator R&S SMT-06	SN: 837633/005	10-Jan-19 (in house check Jan-19)	In house check: Oct-22
Network Analyzer Agilent E8358A	SN: US41080477	31-Mar-14 (in house check Oct-18)	In house check: Oct-19

	Name	Function	Signature
Calibrated by:	Leif Klysner	Laboratory Technician	
Approved by:	Katja Pokovic	Technical Manager	

Issued: August 27, 2019

This calibration certificate shall not be reproduced except in full without written approval of the laboratory.

**Calibration Laboratory of
Schmid & Partner
Engineering AG**
Zeughausstrasse 43, 8004 Zurich, Switzerland



S Schweizerischer Kalibrierdienst
C Service suisse d'étalonnage
S Servizio svizzero di taratura
S Swiss Calibration Service

Accredited by the Swiss Accreditation Service (SAS)
The Swiss Accreditation Service is one of the signatories to the EA
Multilateral Agreement for the recognition of calibration certificates

Accreditation No.: **SCS 0108**

References

- [1] ANSI-C63.19-2011
American National Standard, Methods of Measurement of Compatibility between Wireless Communications
Devices and Hearing Aids.

Methods Applied and Interpretation of Parameters:

- **Coordinate System:** y-axis is in the direction of the dipole arms. z-axis is from the basis of the antenna (mounted on the table) towards its feed point between the two dipole arms. x-axis is normal to the other axes. In coincidence with the standards [1], the measurement planes (probe sensor center) are selected to be at a distance of 15 mm above the top metal edge of the dipole arms.
- **Measurement Conditions:** Further details are available from the hardcopies at the end of the certificate. All figures stated in the certificate are valid at the frequency indicated. The forward power to the dipole connector is set with a calibrated power meter connected and monitored with an auxiliary power meter connected to a directional coupler. While the dipole under test is connected, the forward power is adjusted to the same level.
- **Antenna Positioning:** The dipole is mounted on a HAC Test Arch phantom using the matching dipole positioner with the arms horizontal and the feeding cable coming from the floor. The measurements are performed in a shielded room with absorbers around the setup to reduce the reflections. It is verified before the mounting of the dipole under the Test Arch phantom, that its arms are perfectly in a line. It is installed on the HAC dipole positioner with its arms parallel below the dielectric reference wire and able to move elastically in vertical direction without changing its relative position to the top center of the Test Arch phantom. The vertical distance to the probe is adjusted after dipole mounting with a DASY5 Surface Check job. Before the measurement, the distance between phantom surface and probe tip is verified. The proper measurement distance is selected by choosing the matching section of the HAC Test Arch phantom with the proper device reference point (upper surface of the dipole) and the matching grid reference point (tip of the probe) considering the probe sensor offset. The vertical distance to the probe is essential for the accuracy.
- **Feed Point Impedance and Return Loss:** These parameters are measured using a Vector Network Analyzer. The impedance is specified at the SMA connector of the dipole. The influence of reflections was eliminating by applying the averaging function while moving the dipole in the air, at least 70cm away from any obstacles.
- **E-field distribution:** E field is measured in the x-y-plane with an isotropic E-field probe with 100 mW forward power to the antenna feed point. In accordance with [1], the scan area is 20mm wide, its length exceeds the dipole arm length (180 or 90mm). The sensor center is 15 mm (in z) above the metal top of the dipole arms. Two 3D maxima are available near the end of the dipole arms. Assuming the dipole arms are perfectly in one line, the average of these two maxima (in subgrid 2 and subgrid 8) is determined to compensate for any non-parallelity to the measurement plane as well as the sensor displacement. The E-field value stated as calibration value represents the maximum of the interpolated 3D-E-field, in the plane above the dipole surface.

The reported uncertainty of measurement is stated as the standard uncertainty of measurement multiplied by the coverage factor $k=2$, which for a normal distribution corresponds to a coverage probability of approximately 95%.

Measurement Conditions

DASY system configuration, as far as not given on page 1.

DASY Version	DASY5	V52.10.2
Phantom	HAC Test Arch	
Distance Dipole Top - Probe Center	15 mm	
Scan resolution	dx, dy = 5 mm	
Frequency	2600 MHz \pm 1 MHz	
Input power drift	< 0.05 dB	

Maximum Field values at 2600 MHz

E-field 15 mm above dipole surface	condition	Interpolated maximum
Maximum measured above high end	100 mW input power	84.8 V/m = 38.57 dBV/m
Maximum measured above low end	100 mW input power	83.4 V/m = 38.42 dBV/m
Averaged maximum above arm	100 mW input power	84.1 V/m \pm 12.8 % (k=2)

Appendix (Additional assessments outside the scope of SCS 0108)

Antenna Parameters

Frequency	Return Loss	Impedance
2450 MHz	24.2 dB	44.3 Ω + 1.0 j Ω
2550 MHz	22.2 dB	57.1 Ω + 4.4 j Ω
2600 MHz	20.7 dB	59.5 Ω - 3.5 j Ω
2650 MHz	19.3 dB	55.4 Ω - 10.1 j Ω
2750 MHz	15.6 dB	40.8 Ω - 12.1 j Ω

3.2 Antenna Design and Handling

The calibration dipole has a symmetric geometry with a built-in two stub matching network, which leads to the enhanced bandwidth.

The dipole is built of standard semirigid coaxial cable. The internal matching line is open ended. The antenna is therefore open for DC signals.

Do not apply force to dipole arms, as they are liable to bend. The soldered connections near the feedpoint may be damaged. After excessive mechanical stress or overheating, check the impedance characteristics to ensure that the internal matching network is not affected.

After long term use with 40W radiated power, only a slight warming of the dipole near the feedpoint can be measured.

Impedance Measurement Plot

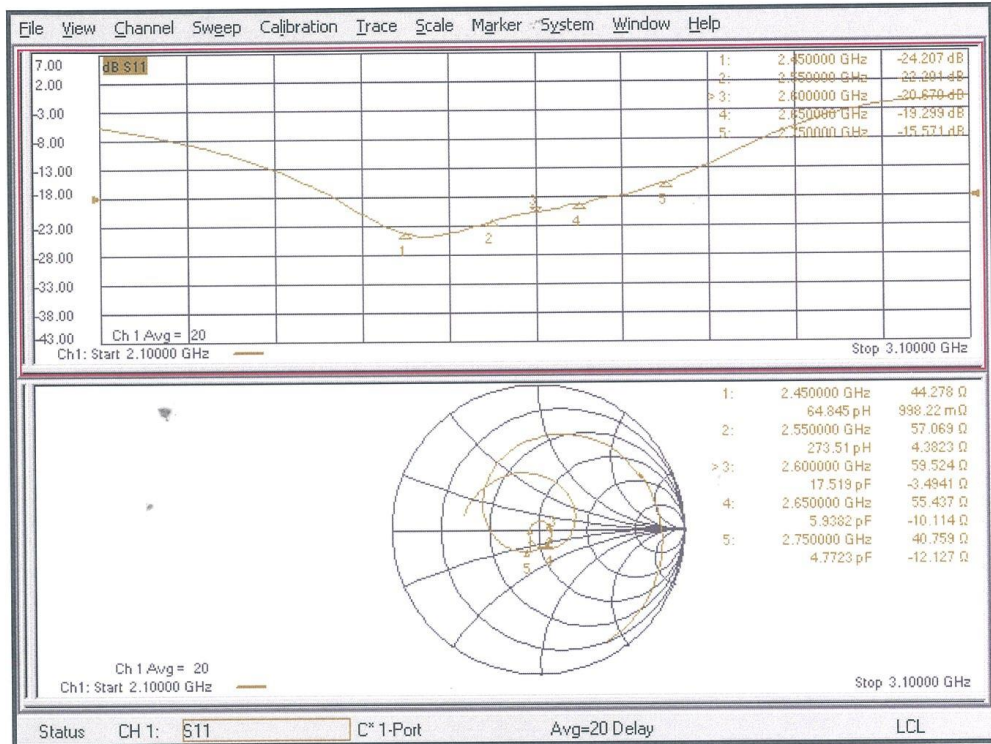

DASY5 E-field Result

Date: 23.08.2019

Test Laboratory: SPEAG Lab2

DUT: HAC Dipole 2600 MHz; Type: CD2600V3; Serial: CD2600V3 - SN: 1017

Communication System: UID 0 - CW ; Frequency: 2600 MHz
 Medium parameters used: $\sigma = 0$ S/m, $\epsilon_r = 1$; $\rho = 0$ kg/m³
 Phantom section: RF Section
 Measurement Standard: DASY5 (IEEE/IEC/ANSI C63.19-2011)

DASY52 Configuration:

- Probe: EF3DV3 - SN4013; ConvF(1, 1, 1) @ 2600 MHz; Calibrated: 03.01.2019
- Sensor-Surface: (Fix Surface)
- Electronics: DAE4 Sn781; Calibrated: 09.01.2019
- Phantom: HAC Test Arch with AMCC; Type: SD HAC P01 BA; Serial: 1070
- DASY52 52.10.2(1504); SEMCAD X 14.6.12(7470)

Dipole E-Field measurement @ 2600MHz/E-Scan - 2600MHz d=15mm/Hearing Aid Compatibility Test (41x181x1):
 Interpolated grid: dx=0.5000 mm, dy=0.5000 mm
 Device Reference Point: 0, 0, -6.3 mm
 Reference Value = 61.02 V/m; Power Drift = 0.01 dB
 Applied MIF = 0.00 dB
 RF audio interference level = 38.57 dBV/m
Emission category: M2

MIF scaled E-field

Grid 1 M2 38.19 dBV/m	Grid 2 M2 38.42 dBV/m	Grid 3 M2 38.34 dBV/m
Grid 4 M2 37.8 dBV/m	Grid 5 M2 38.05 dBV/m	Grid 6 M2 38.02 dBV/m
Grid 7 M2 38.31 dBV/m	Grid 8 M2 38.57 dBV/m	Grid 9 M2 38.51 dBV/m

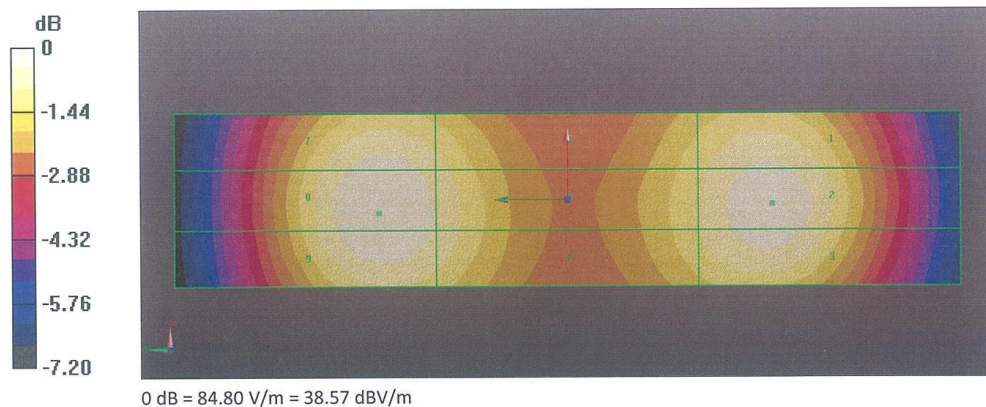

ANNEX F THE EVALUATION OF SPOTCHECK AND GOOGLE DUO

F.1 Validation Result

E-Field Scan						
Mode	Frequency (MHz)	Input Power (mW)	Measured ¹ Value(dBV/m)	Target ² Value(dBV/m)	Deviation ³ (%)	Limit ⁴ (%)
CW	835	100	40.68	40.56	1.39	± 25
CW	1880	100	39.14	38.89	2.92	± 25

Notes:

1. Please refer to the attachment for detailed measurement data and plot.
2. Target value is provided by SPEAD in the calibration certificate of specific dipoles.
3. Deviation (%) = 100 * (Measured value minus Target value) divided by Target value.
4. ANSI C63.19 requires values within ± 25% are acceptable, of which 12% is deviation and 13% is measurement uncertainty. Values independently validated for the dipole actually used in the measurements should be used, when available.

F.2 Spot check results

Frequency		Measured Value(dBV/m)	Power Drift (dB)	Category
MHz	Channel			
GSM 850				
848.8	251	34.95	0.18	M4 (see Fig F.1)
GSM 1900				
1850.2	512	22.73	-0.17	M4 (see Fig F.2)

F.3 The evaluation of Google duo

F.3.1 The evaluation of MIF

Measured MIF levels		
Band	Channel	Modulation interference factor (dB)
GSM 850 EDGE	251	-0.55
	190	-0.48
	128	-0.67
GSM 1900 EDGE	810	-0.23
	661	-0.38
	512	-0.46
WCDMA 850 HSUPA	4233	-21.65
	4182	-20.98
	4132	-21.28



WCDMA 1700 HSUPA	1513	-20.87
	1412	-21.09
	1312	-20.56
WCDMA 1900 HSUPA	9538	-21.25
	9400	-21.42
	9262	-21.67
LTE Band2 QPSK	19100	-14.96
	18900	-15.08
	18700	-14.80
LTE Band4 QPSK	20300	-15.18
	20175	-15.18
	20050	-15.09
LTE Band5 QPSK	20600	-14.80
	20525	-14.98
	20450	-14.79
LTE Band12 QPSK	23130	-14.80
	23095	-15.03
	23060	-14.79
LTE Band14 QPSK	23330	-15.04
LTE Band30 QPSK	27710	-14.99
LTE Band2 16QAM	19100	-9.89
	18900	-10.12
	18700	-10.39
LTE Band4 16QAM	20300	-10.34
	20175	-10.36
	20050	-10.11
LTE Band5 16QAM	20600	-11.29
	20525	-10.35
	20450	-10.36
LTE Band12 16QAM	23130	-11.36
	23095	-10.34
	23060	-10.33
LTE Band14 16QAM	23330	-10.11
LTE Band30 16QAM	27710	-10.61
LTE Band2 64QAM	19100	-10.10
	18900	-10.08
	18700	-11.36
LTE Band4 64QAM	20300	-10.03
	20175	-10.10
	20050	-10.01

LTE Band5 64QAM	20600	-11.12
	20525	-11.13
	20450	-11.10
LTE Band12 64QAM	23130	-10.03
	23095	-10.48
	23060	-11.34
LTE Band14 64QAM	23330	-11.31
LTE Band30 64QAM	27710	-11.25
WiFi-2.4G 11b	11	-6.11
	6	-6.35
	1	-6.27

F.3.2 The evaluation for low-power exemption

Band	Average power (dBm)	MIF (dB)	Sum (dBm)	C63.19 Tested
GSM 850 - EDGE	30.89	-0.48	30.41	Yes*
GSM 1900 - EDGE	27.20	-0.23	26.97	Yes*
WCDMA 850 - HSPA	22.71	-20.98	1.73	No
WCDMA 1700 - HSPA	20.46	-20.56	-0.1	No
WCDMA 1900 - HSPA	20.98	-21.25	-0.27	No
LTE Band 2 QPSK	23.61	-14.80	8.81	No
LTE Band 4 QPSK	23.04	-15.09	7.95	No
LTE Band 5 QPSK	24.28	-14.78	9.5	No
LTE Band 12 QPSK	23.65	-14.79	8.86	No
LTE Band 14 QPSK	23.37	-15.04	8.33	No
LTE Band 30 QPSK	22.69	-14.99	7.7	No
LTE Band 2 16QAM	22.86	-9.89	12.97	No
LTE Band 4 16QAM	22.25	-10.11	12.14	No
LTE Band 5 16QAM	23.45	-10.35	13.1	No
LTE Band 12 16QAM	22.69	-10.33	12.36	No
LTE Band 14 16QAM	22.51	-10.11	12.4	No
LTE Band 30 16QAM	21.87	-10.61	11.26	No
LTE Band 2 64QAM	21.15	-10.08	11.07	No
LTE Band 4 64QAM	21.18	-10.01	11.17	No
LTE Band 5 64QAM	22.56	-11.10	11.46	No
LTE Band 12 64QAM	21.68	-10.03	11.65	No
LTE Band 14 64QAM	21.44	-11.31	10.13	No
LTE Band 30 64QAM	21.08	-11.25	9.83	No
WiFi 2.4G 11b	20.29	-6.35	13.94	No

*Note: For GSM bands, EDGE modes were not evaluated as Voice modes were found to the worst-case modes for the GSM air interface.

F.4 System Validation Result

E SCAN of Dipole 835 MHz

Date: 2020-1-12

Electronics: DAE4 Sn1331

Medium: Air

Medium parameters used: $\sigma = 0$ mho/m, $\epsilon_r = 1$; $\rho = 1000$ kg/m³

Communication System: CW; Frequency: 835 MHz; Duty Cycle: 1:1

Probe: EF3DV3 - SN4060;ConvF(1, 1, 1)

E Scan - measurement distance from the probe sensor center to CD835 Dipole =

15mm/Hearing Aid Compatibility Test (41x361x1): Interpolated grid: dx=0.5000 mm, dy=0.5000 mm

Device Reference Point: 0, 0, -6.3 mm

Reference Value = 129.6 V/m; Power Drift = -0.05 dB

Applied MIF = 0.00 dB

RF audio interference level = 40.68 dBV/m

Emission category: M3

MIF scaled E-field

Grid 1 M3 40.25 dBV/m	Grid 2 M3 40.68 dBV/m	Grid 3 M3 40.59 dBV/m
Grid 4 M4 35.46 dBV/m	Grid 5 M4 35.81 dBV/m	Grid 6 M4 35.79 dBV/m
Grid 7 M3 40.44 dBV/m	Grid 8 M3 40.64 dBV/m	Grid 9 M3 40.52 dBV/m

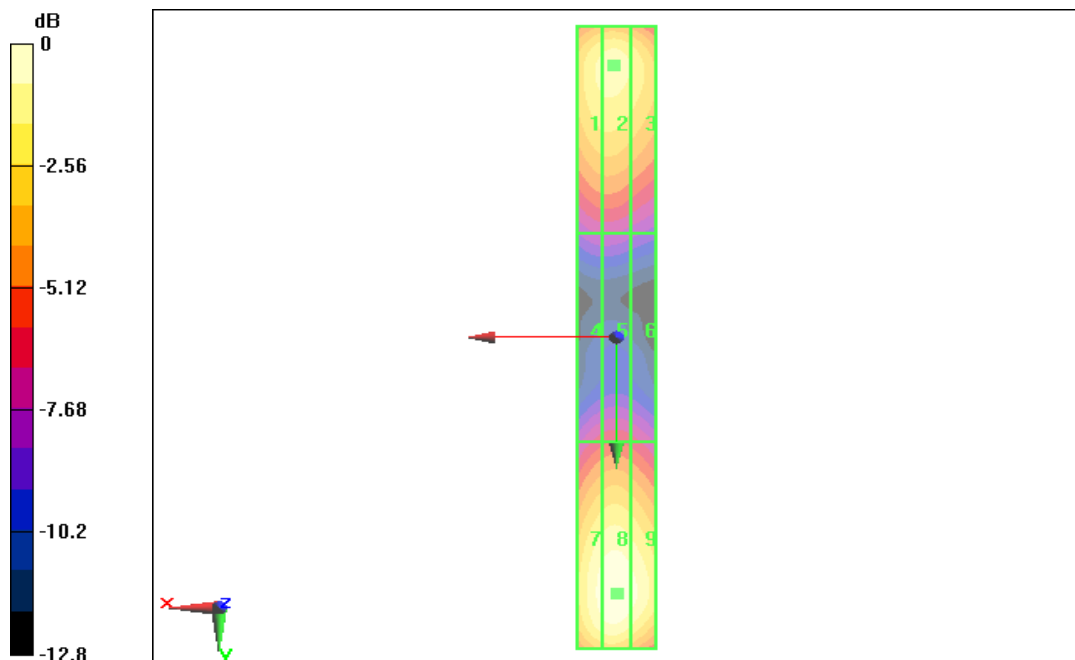

0 dB = 40.68 dBV/m

E SCAN of Dipole 1880 MHz

Date: 2020-1-13

Electronics: DAE4 Sn1331

Medium: Air

Medium parameters used: $\sigma = 0$ mho/m, $\epsilon_r = 1$; $\rho = 1000$ kg/m³

Communication System: CW; Frequency: 1880 MHz; Duty Cycle: 1:1

Probe: EF3DV3 - SN4060;ConvF(1, 1, 1)

E Scan - measurement distance from the probe sensor center to CD1880 Dipole = 15mm/Hearing Aid Compatibility Test (41x181x1): Interpolated grid: dx=0.5000 mm, dy=0.5000 mm

Device Reference Point: 0, 0, -6.3 mm

Reference Value = 157.2 V/m; Power Drift = -0.04 dB

Applied MIF = 0.00 dB

RF audio interference level = 39.14 dBV/m

Emission category: M2

MIF scaled E-field

Grid 1 M2 38.81 dBV/m	Grid 2 M2 39.14 dBV/m	Grid 3 M2 39.04 dBV/m
Grid 4 M2 36.23 dBV/m	Grid 5 M2 36.41 dBV/m	Grid 6 M2 36.36 dBV/m
Grid 7 M2 38.86 dBV/m	Grid 8 M2 39.08 dBV/m	Grid 9 M2 38.88 dBV/m

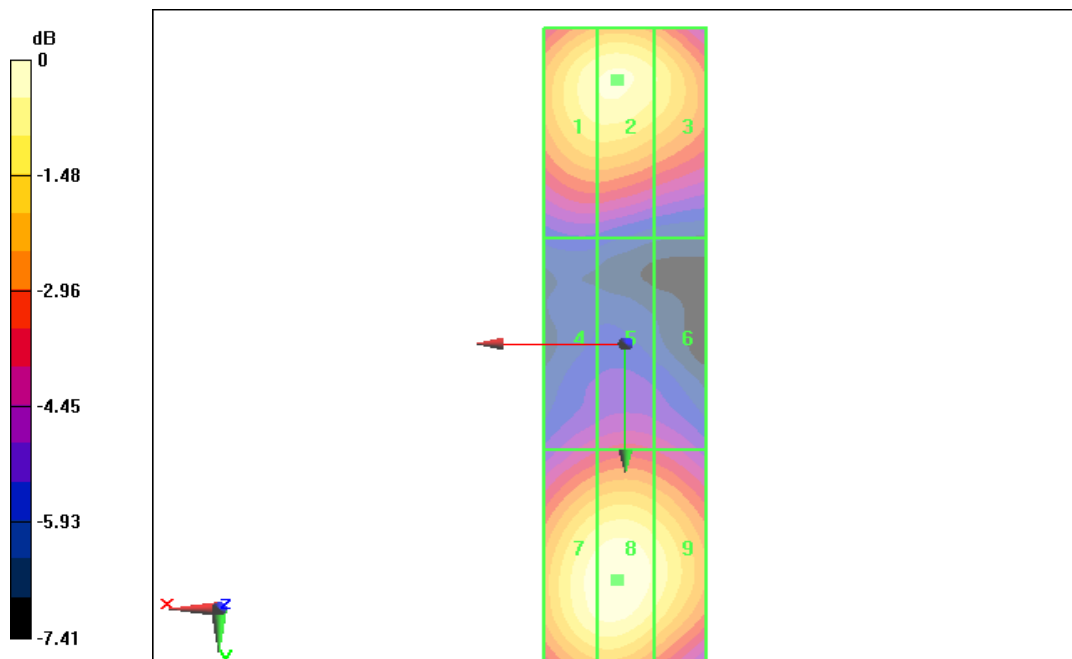

0 dB = 39.14 dBV/m

F.5 Test Plots

HAC RF E-Field GSM 850 High

Date: 2020-1-12

Electronics: DAE4 Sn1331

Medium: Air

Medium parameters used: $\sigma = 0$ mho/m, $\epsilon_r = 1$; $\rho = 1000$ kg/m³

Ambient Temperature: 22.0°C

Communication System: GSM 850; Frequency: 848.8 MHz; Duty Cycle: 1:8.3

Probe: EF3DV3 - SN4060;ConvF(1, 1, 1)

GSM850/E Scan - ER3DV6 - 2011: 15 mm from Probe Center to the Device/Hearing Aid

Compatibility Test (101x101x1): Interpolated grid: dx=0.5000 mm, dy=0.5000 mm

Device Reference Point: 0, 0, -6.3 mm

Reference Value = 46.07 V/m; Power Drift = 0.18 dB

Applied MIF = 3.34 dB

RF audio interference level = 34.95 dBV/m

Emission category: M4

MIF scaled E-field

Grid 1 M4 33.9 dBV/m	Grid 2 M4 34.19 dBV/m	Grid 3 M4 33.6 dBV/m
Grid 4 M4 34.62 dBV/m	Grid 5 M4 34.95 dBV/m	Grid 6 M4 34.44 dBV/m
Grid 7 M4 35.15 dBV/m	Grid 8 M4 35.36 dBV/m	Grid 9 M4 34.7 dBV/m

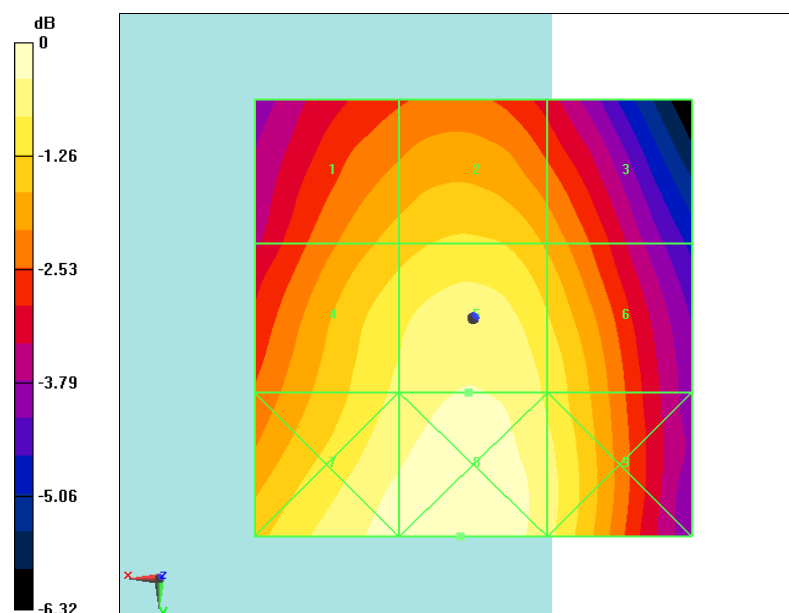

0 dB = 58.61 V/m = 35.36 dBV/m

Fig F.1 HAC RF E-Field GSM 850 High

HAC RF E-Field GSM 1900 Low

Date: 2020-1-13

Electronics: DAE4 Sn1331

Medium: Air

Medium parameters used: $\sigma = 0$ mho/m, $\epsilon_r = 1$; $\rho = 1000$ kg/m³

Ambient Temperature: 22.0°C

Communication System: PCS 1900; Frequency: 1850.2 MHz; Duty Cycle: 1:8.3

Probe: EF3DV3 - SN4060;ConvF(1, 1, 1)

GSM1900/E Scan - ER3DV6 - 2011: 15 mm from Probe Center to the Device 3/Hearing Aid Compatibility Test (101x101x1): Interpolated grid: dx=0.5000 mm, dy=0.5000 mm

Device Reference Point: 0, 0, -6.3 mm

Reference Value = 6.229 V/m; Power Drift = -0.17 dB

Applied MIF = 3.36 dB

RF audio interference level = 22.73 dBV/m

Emission category: M4

MIF scaled E-field

Grid 1 M4 22.5 dBV/m	Grid 2 M4 22.73 dBV/m	Grid 3 M4 22.08 dBV/m
Grid 4 M4 19.55 dBV/m	Grid 5 M4 21.24 dBV/m	Grid 6 M4 21.4 dBV/m
Grid 7 M4 25.32 dBV/m	Grid 8 M4 24.95 dBV/m	Grid 9 M4 23.99 dBV/m

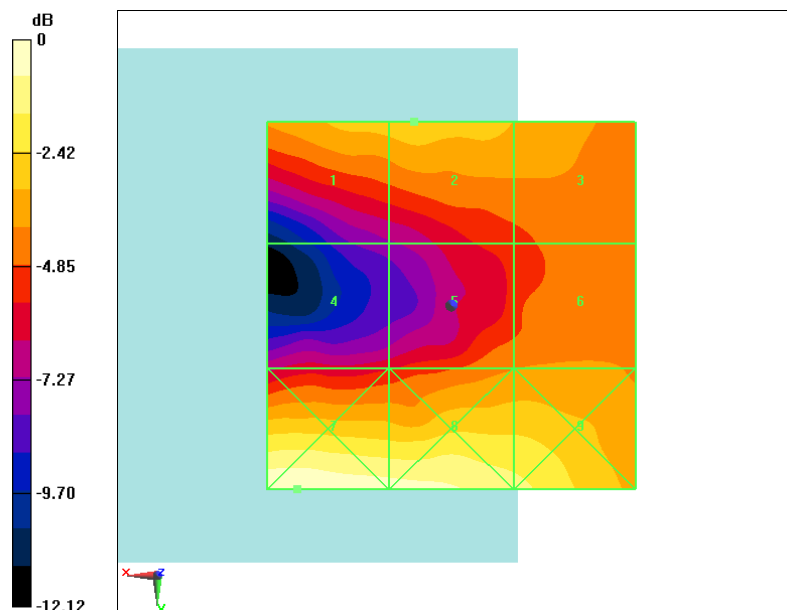

0 dB = 18.44 V/m = 25.32 dBV/m

Fig F.2 HAC RF E-Field GSM 1900 Low



The photos of HAC test are presented in the additional document:

Appendix to test report No.I19Z62348-SEM01/02

The photos of HAC test