



TO: UBEE

SPECIFICATION FOR APPROVAL

CUSTOMER DWG. No./PART No. : NA REV. : NA

DESCRIPTION : Ubee_U10C149-WIF4

FOXCONN PART. No. : ANTP2M2-CUB18-EH REV. : X1

ATTACHMENTS:

- 1. CUSTOMER DRAWING2
- 2. TEST REPORT3~20
- 3. SPP21~24

PLEASE RETURN TO FOXCONN ONE COPY OF

APPROVED SIGNATURES

Approved by : Minda Liu

Checked by: Erin Dong

Prepared by: Wang Qin

File No.: ANTP2M2-CUB18-EH

Revision No.: X1

Date: 2019/12/3

REV.	ECN. NO.	APPD.
X1	BS-20-002828	York.xiong
X2	BS-20-003228	York.xiong

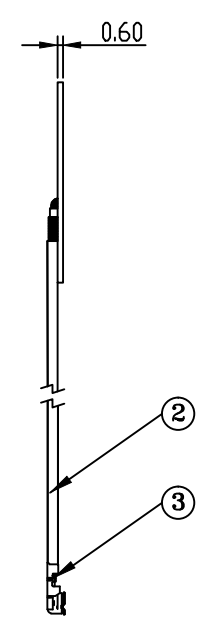
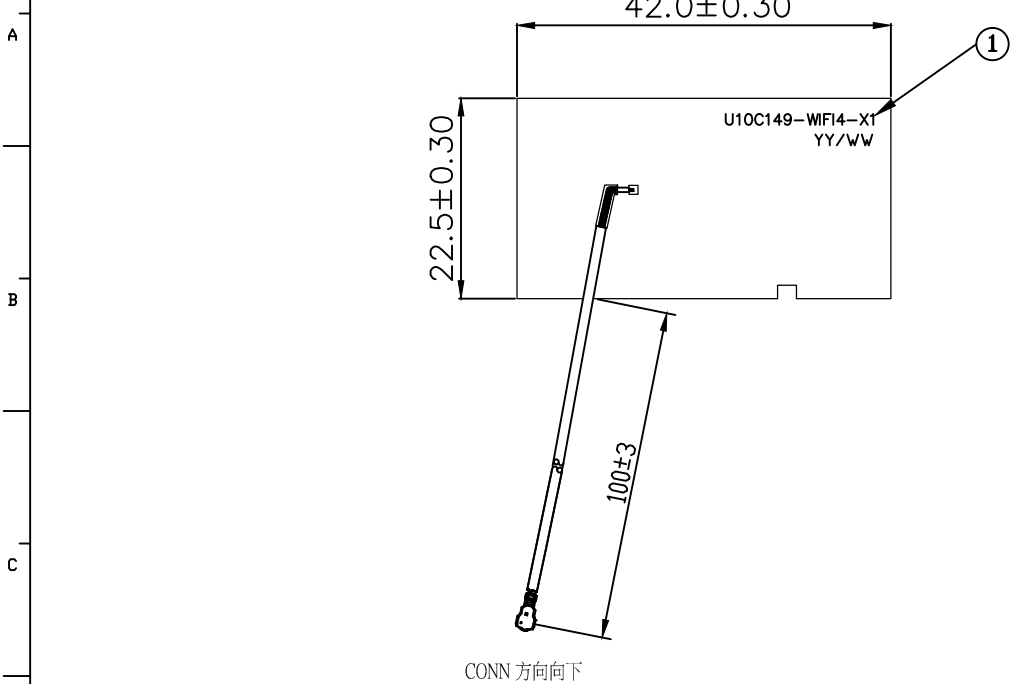

CONN 方向向下

註解：

1. HARMFUL MATERIAL CONTROL PLEASE FOLLOW DOC. NO."EPI12"
有害物質控制請遵循Doc "EPI12"
- 2.HARMFUL MATERIAL CONTROL PLEASE FOLLOW "ROHS".
(BR<900PPM,CL<900PPM,BR+CL<1500PPM).
鹵素需滿足(BR<900PPM,CL<900PPM,BR+CL<1500PPM).
- 3.PLEASE CONTACT FIT SALES REPRESENTATIVE TO VERIFY PRODUCT DETAILS&AVAILABILITY
關於產品有效性情況請與FIT業務代表聯繫

3	Connector	MHF Plug,Gold Plated,Halogen Free Type,I-PEX1
2	Cable	ø1.13mm Coaxial Cable,FEP Blue Jacket
1	PCB	PCB Size:42*22.5*0.6mm
NO	ITEM	DESCRIPTION

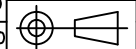
X.± 1.00	X.*±	UNITS mm	NAME<INTENDED USE> CUSTOMER	 FIT FOXCONN INTERCONNECT TECHNOLOGY LIMITED.
.X± 0.30	.X*±	MAT'L	PART NO.<INTENDED USE> ANTP2M2-CUB18-EH	
.XX± 0.20	.XX*±	FINISH	APPD: York.xiong 02/18'20	CLASS: <input type="checkbox"/> CONFIDENTIAL <input type="checkbox"/> SECRET <input checked="" type="checkbox"/> GENERAL
.XXX±	.XXX*±		Q'TY	CHKD: Sheng.tai 02/18'20
THESE DRAWINGS AND SPECIFICATIONS ARE THE PROPERTY OF FOXCONN INTERCONNECT TECHNOLOGY LIMITED AND SHALL NOT BE REPRODUCED, COPIED OR USED IN ANY MANNER WITHOUT THE PRIOR WRITTEN CONSENT OF FOXCONN INTERCONNECT TECHNOLOGY LIMITED.			DRAW: Irene.su 02/18'20	DWG NO.: 389-0000-874
			 SCALE SHEET REV. 1:1 4/4 X2	

1. Specifications for antennas

FrequencyRange(GHz)	2.4GHz ~ 2.5GHz; 5.05GHz~5.85GHz
VSWR	< 2
Efficiency (%)	≥70%
Peak Gain (dBi)	@2GHz< 4 [dBi] @5GHz< 5 [dBi]
Radio Connector	IPEX MHF I or Compatible
Impedance	50Ω Nominal
Cable Diameter	1.13mm cable
Cable color	Blue
Antenna Type	Dipole
Cable Loss	0.212dB @ 2.4GHz; 0.329dB @ 5GHz
Polarization	Linear

2. Antenna Dimension / Cable length

Product	U10C149
WLAN Antenna	PCB W/100mm Cable,

3. Antenna Pictures

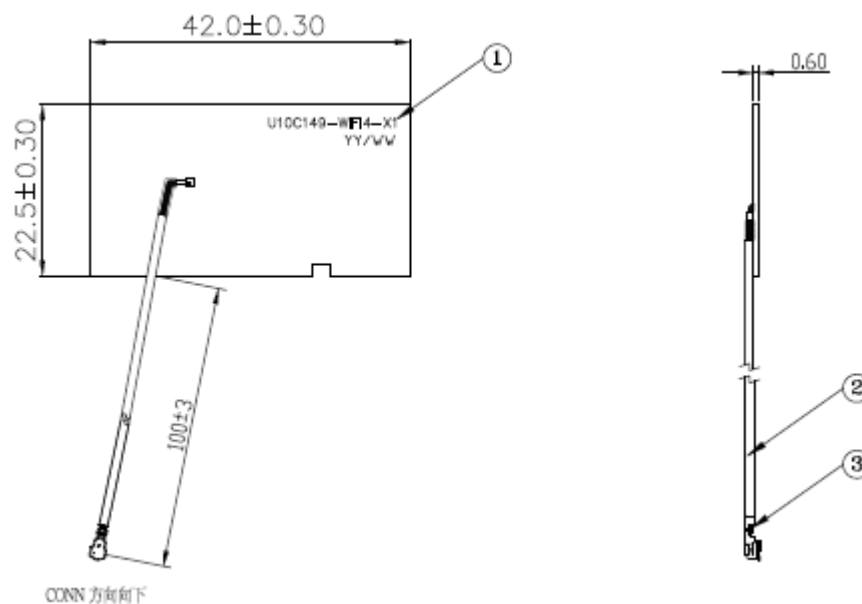



Project Name: **U10C149**

Rev. V1

Test Date: 11-25-2019

Report Date: 11-28-2019

Contact Information:

Charles Lee[charles.ch.lee@fit-foxconn.com]

Project: U10C149	Date: 2019/11/28
Antenna Designer: Charles Lee	
Rev.: V1	Note:

History

Revision	Date	Description
V1	2019/11/28	Initial Release.

Project: U10C149	Date: 2019/11/28
Antenna Designer: Charles Lee	
Rev.: V1	Note:

Contents

1.	SUMMARY	4
2.	GENERAL DESCRIPTION	4
2.1.	ANTENNA PLACEMENT	5
2.2.	TEST FIXTURE SETUP	6
3.	ANTENNA TEST ENVIRONMENT	6
4.	MEASUREMENT DATA	8
4.1.	ANTENNA SPECIFICATION	8
4.2.	ANTENNA VSWR	9
4.3.	ANTENNA ISOLATIONS	10
4.4.	CHART OF ANTENNA PEAK GAIN	11
4.5.	TABLE OF ANTENNA PERFORMANCE	11
5.	CONCLUSION	12
6.	APPENDICES A	13
6.1.	CABLE ATTENUATION	13
6.2.	ANTENNA 3D GRAPH	14
6.2.1.	WiFi#4	14
6.3.	ANTENNA 2D GRAPH	15
6.3.1.	WiFi#4	15
7.	ANTENNA TOTAL PERFORMANCE	17

Project: U10C149	Date: 2019/11/28
Antenna Designer: Charles Lee	
Rev.: V1	Note:

1. Summary

This report summarizes all antennas performance to support U10C149 project.

WIFI X 4

2. General Description

Model: Cable Modem.

Antennas are designed on PCB.

Coaxial cable connected PCB directly, which placed on the side wall.

Project: U10C149	Date: 2019/11/28
Antenna Designer: Charles Lee	
Rev.: V1	Note:

2.2. Test Fixture Setup

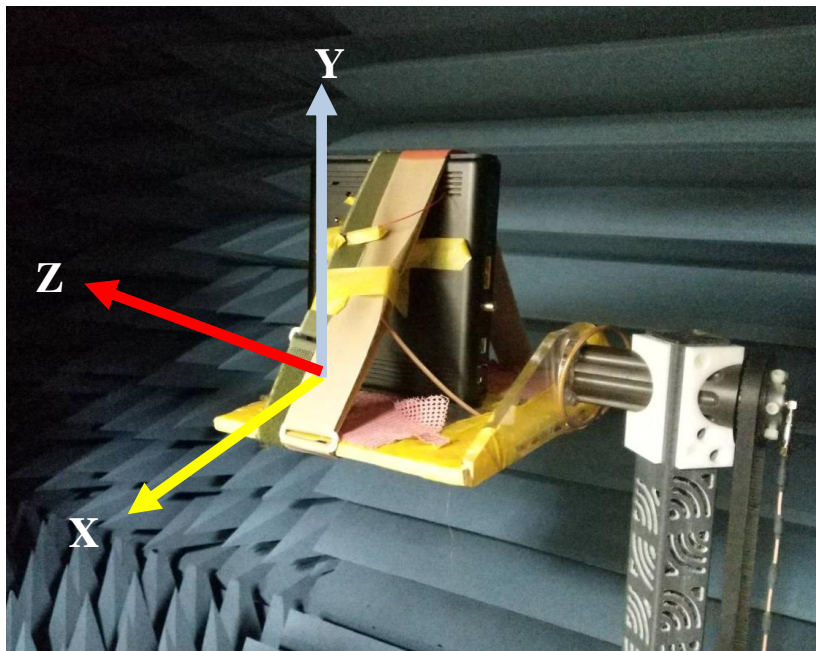
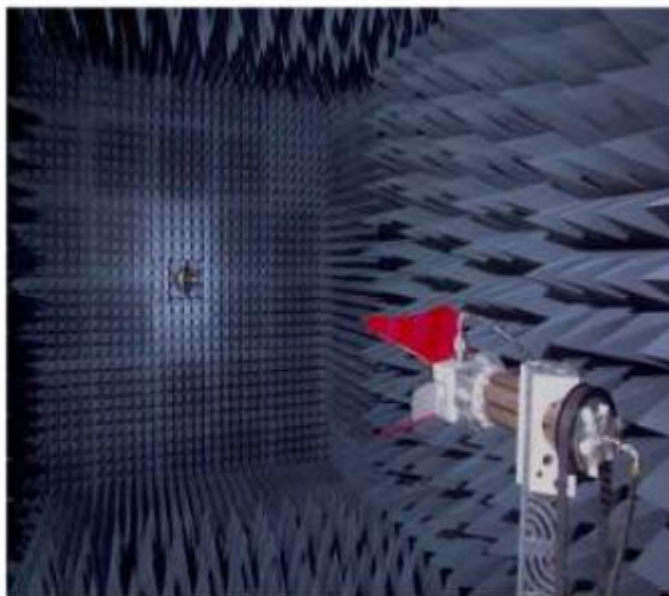

Figure 3 Environment of Setup.

3. Antenna Test Environment



Chamber Dimension: 7.3 * 3.66 * 3.66 m

Frequency Range: 700 MHz~6 GHz

- 3D Antenna Chamber adopted ETS-Lindgren's AMS-8500 system which is authorized by CTIA and it can satisfy test items of different antenna products, such as NB, cellular phone, AP, GPS...etc.
- It can support passive antenna measurement function for antenna designer to verify antenna characteristics such as 2D/3D radiation pattern measurement, efficiency, VSWR, and Isolation.
- Certification by TAF in 2010
- Add active antenna measurement function for OTA testing items such as TRP, TIS in 2010 4Q.

Figure 4 3D Chamber

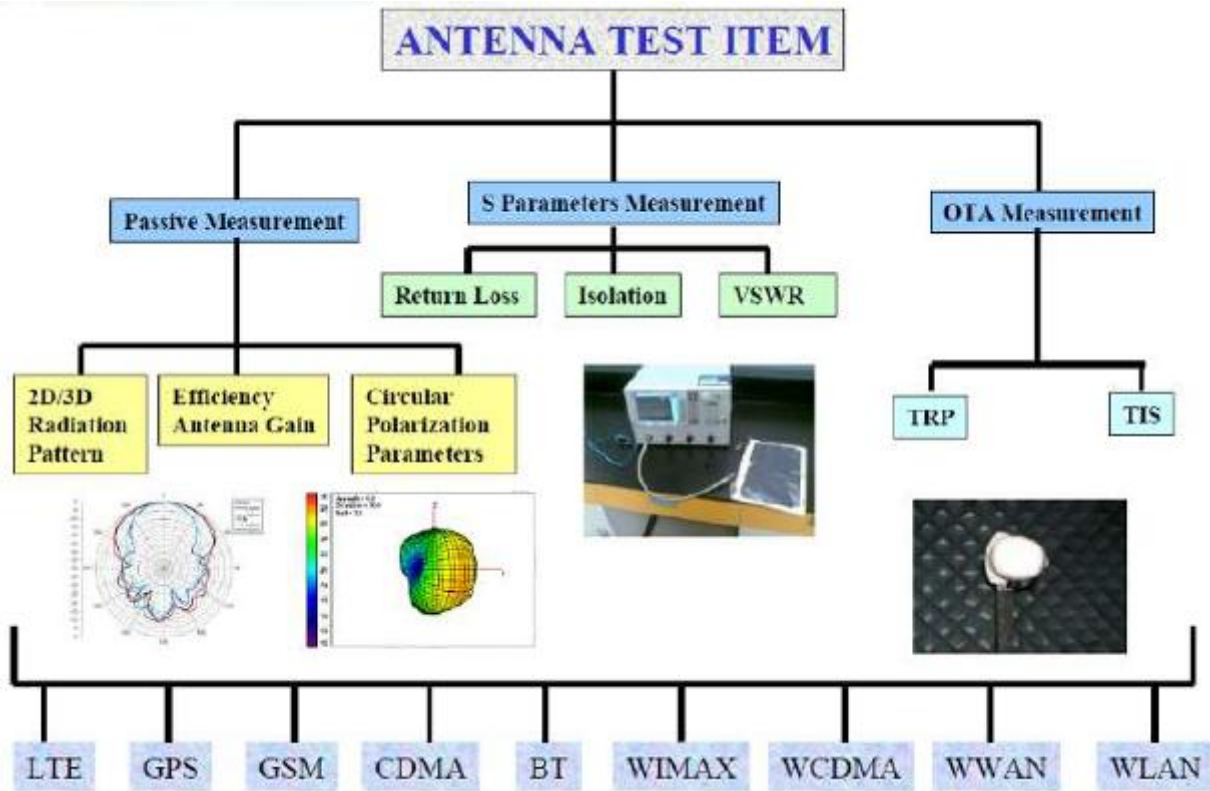
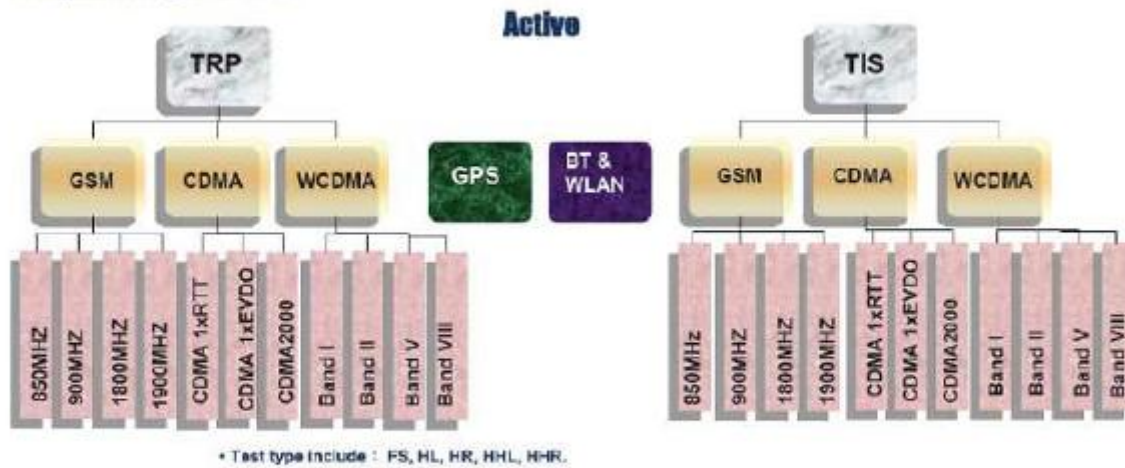

Figure 5 Chamber Compatibility

Capability Of OTA



OTA test function will be certificate by TAF in 2011 4Q

Figure 6 Chamber Capability

Project: U10C149	Date: 2019/11/28
Antenna Designer: Charles Lee	
Rev.: V1	Note:

4. Measurement Data

4.1. Antenna Specification

Specifications	
Items	Ant.1 ~ Ant.4 (WIFI)
Antenna Type	Dipole Antenna
Frequency	2.4/5 [GHz]
VSWR	< 2
Efficiency	≥70%
Isolation	> 20 [dB]
Peak Gain	@2GHz< 4 [dBi] @5GHz< 5 [dBi]
Impedances	50 ohms
Cable Length	WIFI#1: 155mm WIFI#2: 87mm WIFI#3: 75mm WIFI#4: 100mm
Antenna Size	WIFI#1: 42X22.5X0.6mm ³ WIFI#2: 35X26.5X0.6mm ³ WIFI#3: 42X22.5X0.6mm ³ WIFI#4: 42X22.5X0.6mm ³

Figure 7 Antenna Criteria and measured items

4.2. Antenna VSWR

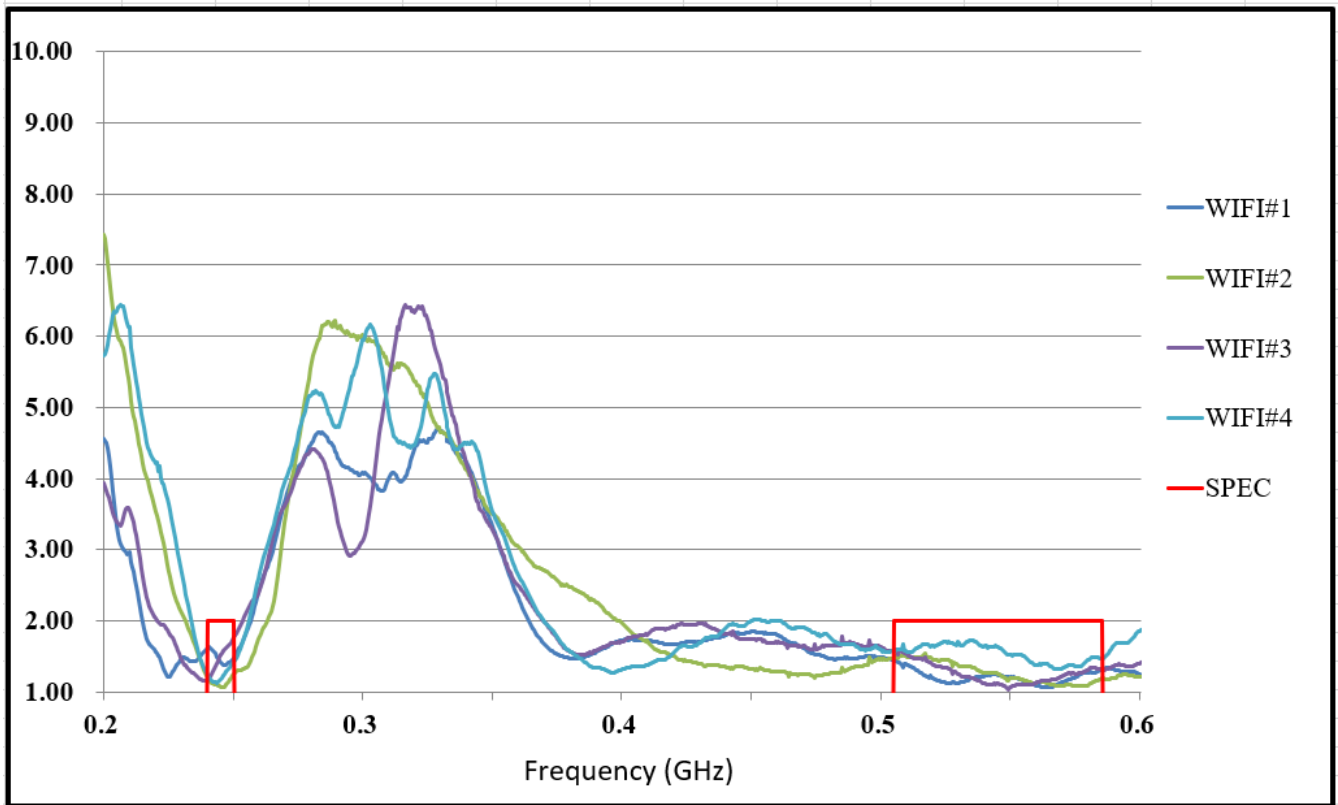

Freq [MHz]	2400	2450	2500	5050	5150	5350	5725	5825
WIFI#1	1.62	1.42	1.47	1.44	1.28	1.20	1.17	1.28
WIFI#2	1.20	1.07	1.25	1.48	1.50	1.35	1.10	1.15
WIFI#3	1.18	1.52	1.77	1.58	1.47	1.20	1.26	1.34
WIFI#4	1.23	1.18	1.42	1.58	1.64	1.73	1.37	1.49

Figure 8 Chart of VSWR

4.3. Antenna Isolations

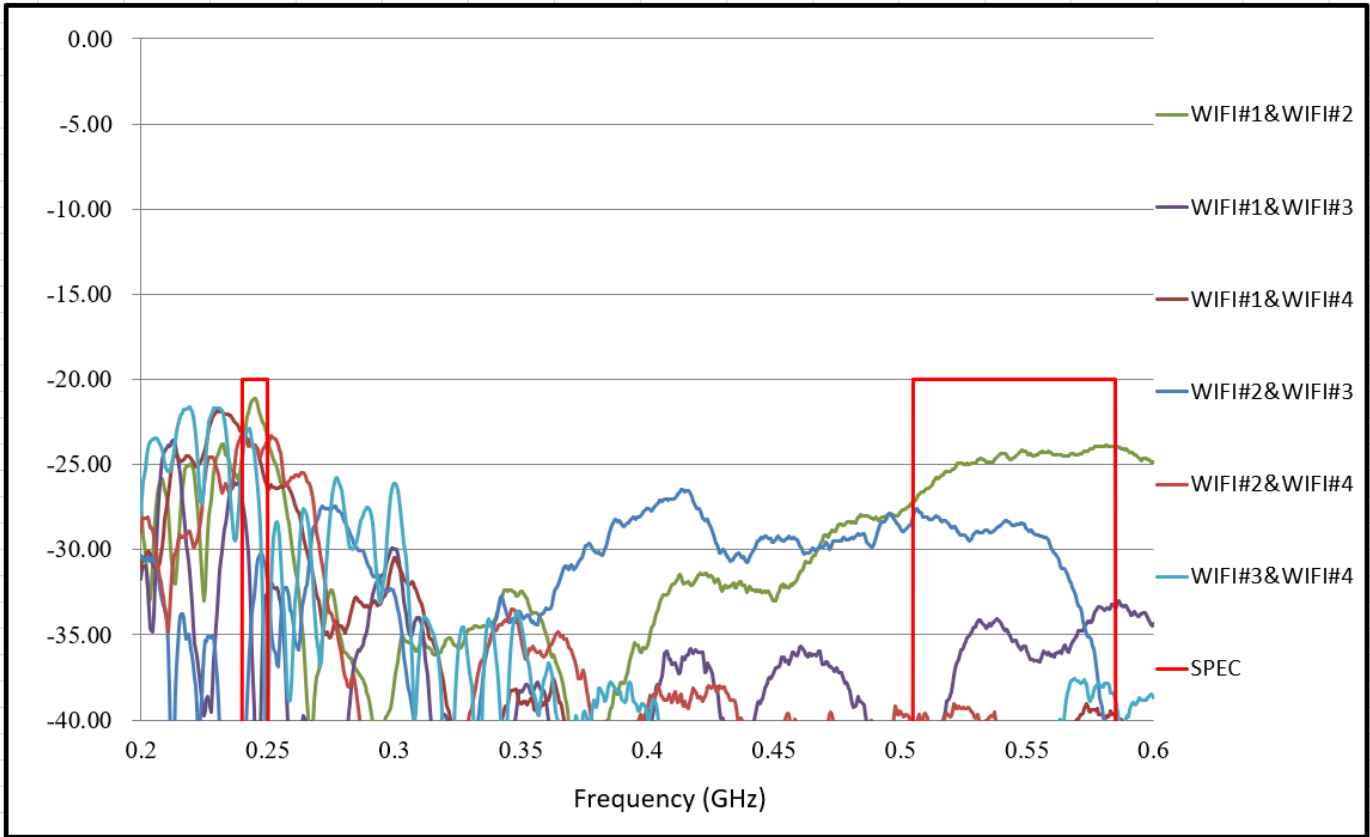

Freq [MHz]	2400	2450	2500	5050	5150	5350	5725	5825
WiFi#1&WiFi#2	-24.52	-21.13	-23.43	-27.19	-25.82	-24.86	-24.19	-23.95
WiFi#1&WiFi#3	-27.16	-43.07	-32.62	-45.28	-41.17	-34.43	-34.57	-33.46
WiFi#1&WiFi#4	-23.09	-23.96	-26.36	-51.67	-52.40	-49.19	-39.35	-39.72
WiFi#2&WiFi#3	-41.19	-31.94	-31.91	-27.99	-28.08	-28.93	-34.48	-42.30
WiFi#2&WiFi#4	-23.16	-23.90	-23.68	-40.53	-41.58	-39.88	-44.45	-50.64
WiFi#3&WiFi#4	-24.61	-24.98	-43.00	-42.01	-43.06	-44.30	-37.64	-38.00

Figure 9 Chart of Isolation

4.4. Chart of Antenna Peak Gain

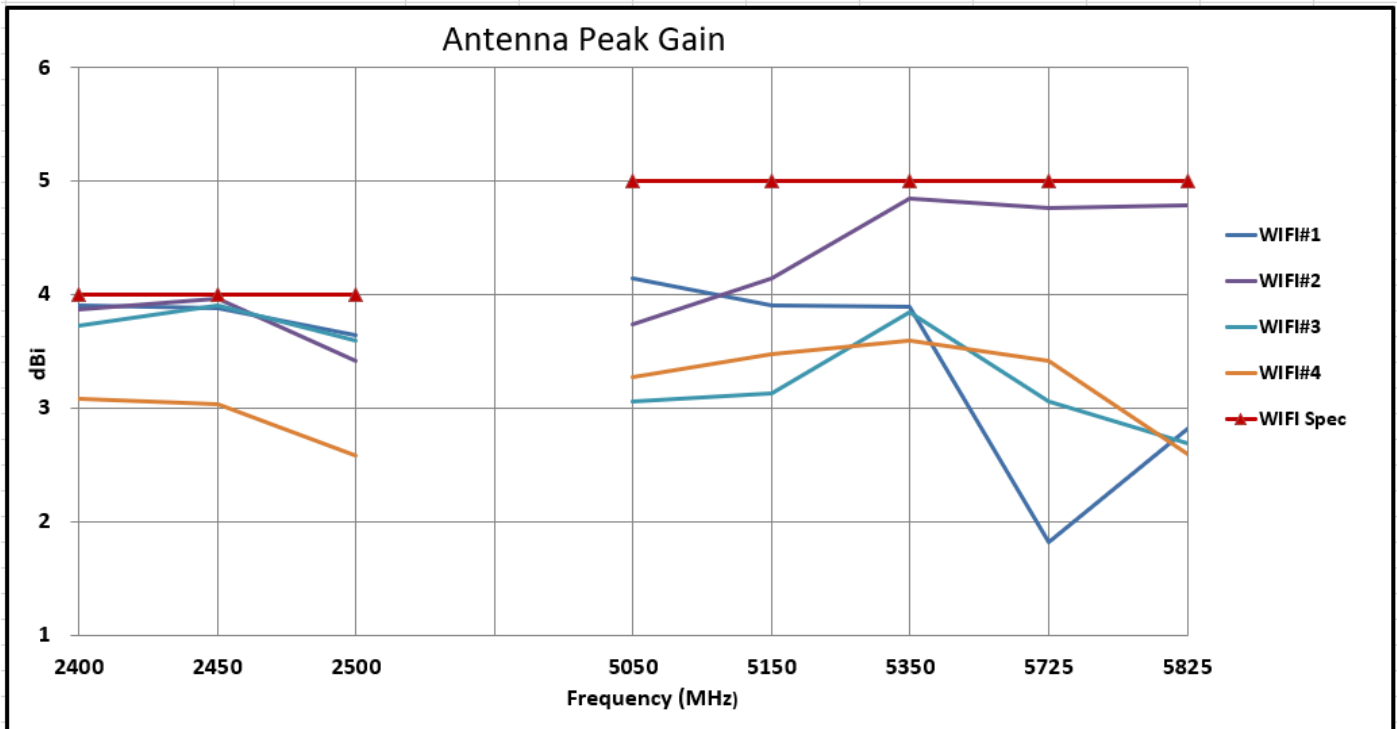

Figure 10 Chart of Peak Gain

4.5. Table of Antenna Performance

Antenna	Frequency(MHz)	2400	2450	2500	5050	5150	5350	5725	5825
WIFI#1	Peak Gain	3.90	3.88	3.64	4.14	3.90	3.90	1.82	2.82
	Avg. Gain	-1.35	-1.11	-1.30	-1.29	-1.32	-1.19	-1.32	-1.49
	Efficiency%	73.34	77.45	74.15	74.27	73.76	76.01	73.74	70.96
WIFI#2	Peak Gain	3.87	3.97	3.41	3.74	4.15	4.84	4.76	4.78
	Avg. Gain	-1.29	-1.30	-1.24	-1.30	-1.11	-1.22	-1.31	-1.35
	Efficiency%	74.26	74.20	75.09	74.18	77.45	75.45	73.94	73.35
WIFI#3	Peak Gain	3.73	3.90	3.59	3.05	3.13	3.85	3.05	2.69
	Avg. Gain	-1.22	-1.30	-1.29	-1.32	-1.37	-1.28	-1.19	-1.14
	Efficiency%	75.58	74.15	74.22	73.77	72.90	74.46	76.11	76.84
WIFI#4	Peak Gain	3.08	3.04	2.58	3.28	3.47	3.59	3.42	2.60
	Avg. Gain	-1.48	-1.21	-1.42	-1.29	-1.26	-1.20	-1.21	-1.44
	Efficiency%	71.18	75.65	72.13	74.26	74.77	75.84	75.65	71.74

Figure 11 Table of Antenna Performance

Antenna	Frequency(MHz)	2400	2450	2500	5050	5150	5350	5725	5825
WIFI Spec	Peak Gain	4.0	4.0	4.0	5.0	5.0	5.0	5.0	5.0
	Avg. Gain	-1.6	-1.6	-1.6	-1.6	-1.6	-1.6	-1.6	-1.6
	Efficiency%	70.0	70.0	70.0	70.0	70.0	70.0	70.0	70.0

Figure 12 Antenna Criteria

Project: U10C149	Date: 2019/11/28
Antenna Designer: Charles Lee	
Rev.: V1	Note:

5. Conclusion

There are 4 dipole WIFI antennas in this project. We suggest that all the cable routings need to separate independently, so as to reduce antenna isolation interference from each other(WIFI#1: 155mm; WIFI#2: 87mm; WIFI#3: 75mm; WIFI#4: 100mm). Thus, the antenna performance can meet the specifications. Next, we will maintain the antenna efficiency to the following up schedule.

Project: U10C149	Date: 2019/11/28
Antenna Designer: Charles Lee	
Rev.: V1	Note:

6. Appendices A

6.1. Cable Attenuation

Frequency(GHz)	1GHz	2GHz	3GHz	4GHz	5GHz	6GHz
1.13mm	1.57dB/M	2.26dB/M	2.79dB/M	3.24.dB/M	3.5dB/M	4.05dB/M

1.13mm	Ant#1	2.4G	0.407 dB
coaxial	155mm	5G	0.630 dB
1.13mm	Ant#2	2.4G	0.197 dB
coaxial	87mm	5G	0.305 dB
1.13mm	Ant#3	2.4G	0.165 dB
coaxial	75mm	5G	0.256 dB
1.13mm	Ant#4	2.4G	0.212 dB
coaxial	100mm	5G	0.329 dB

Figure 13 Attenuation Table

Project: U10C149	Date: 2019/11/28
Antenna Designer: Charles Lee	
Rev.: V1	Note:

6.2. Antenna 3D graph

6.2.1. WiFi#4

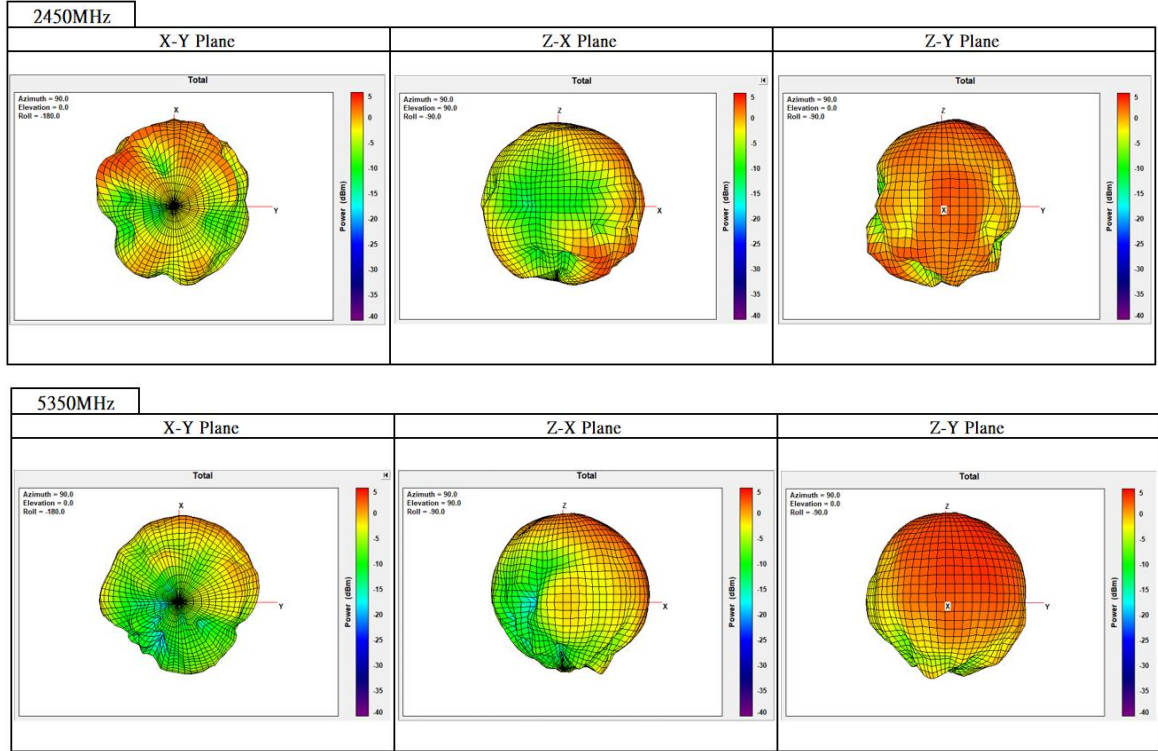

6.3. Antenna 2D graph

6.3.1. WiFi#4

Frequency (MHz)	XY-Plane					
	H-pol		V-pol		Total-pol	
	peak	Avg	peak	Avg	peak	Avg
2400	-2.33	-8.13	2.83	-3.30	3.08	-2.07
2450	-1.16	-6.80	2.69	-3.55	3.04	-1.87
2500	-2.05	-7.11	1.62	-4.11	2.15	-2.34
5060	-9.76	-16.08	2.98	-1.81	3.01	-1.65
5150	-10.05	-16.08	2.92	-1.83	2.94	-1.67
5350	-9.42	-15.15	2.63	-1.92	2.65	-1.71
5725	-7.39	-12.75	2.98	-1.65	3.18	-1.32
5825	-7.88	-13.10	2.44	-1.89	2.51	-1.57

Frequency (MHz)	ZX-Plane					
	H-pol		V-pol		Total-pol	
	peak	Avg	peak	Avg	peak	Avg
2400	-1.87	-5.80	2.83	-1.75	3.08	-0.31
2450	-1.21	-4.92	2.69	-1.98	3.04	-0.17
2500	-1.15	-5.53	2.33	-2.24	2.58	-0.57
5060	-0.80	-10.25	3.16	-0.76	3.28	-0.30
5150	-1.08	-10.06	3.31	-0.71	3.47	-0.23
5350	-0.62	-8.25	3.22	-0.74	3.59	-0.08
5725	-0.92	-7.13	2.54	-1.60	3.42	-0.53
5825	-1.05	-7.31	2.06	-2.18	2.60	-1.02

Frequency (MHz)	ZY-Plane					
	H-pol		V-pol		Total-pol	
	peak	Avg	peak	Avg	peak	Avg
2400	1.25	-4.50	-2.94	-9.25	2.24	-3.25
2450	2.70	-3.31	-1.36	-8.49	3.24	-2.16
2500	2.70	-3.49	-1.16	-5.98	3.16	-2.13
5060	3.22	-3.44	-0.80	-5.35	3.83	-1.52
5150	2.64	-3.59	-1.03	-5.35	3.26	-1.37
5350	2.27	-3.48	-0.62	-5.31	2.88	-1.29
5725	2.41	-4.13	0.95	-2.75	3.79	-0.37
5825	2.08	-4.35	0.65	-2.64	3.12	-0.40

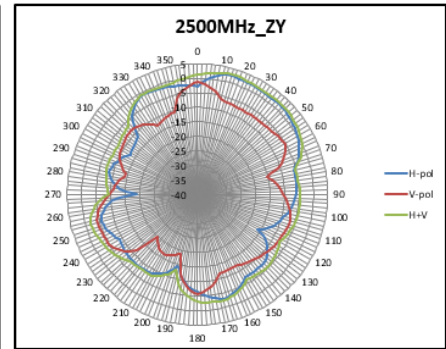
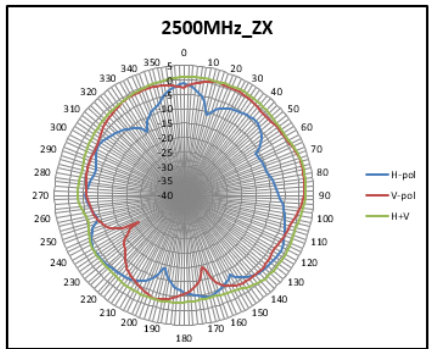
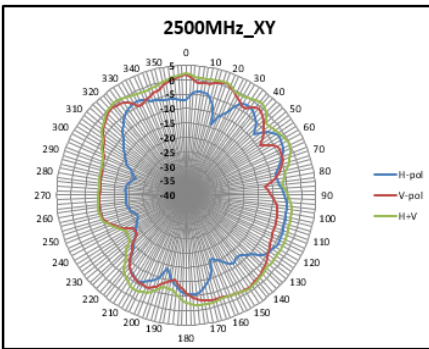
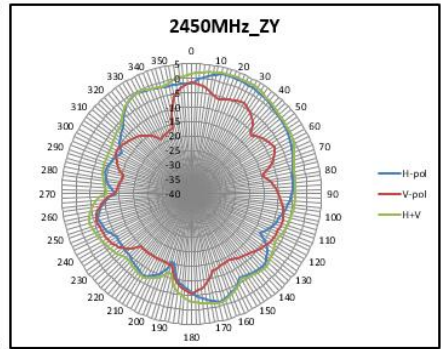
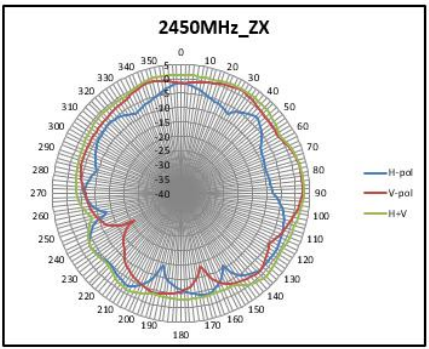
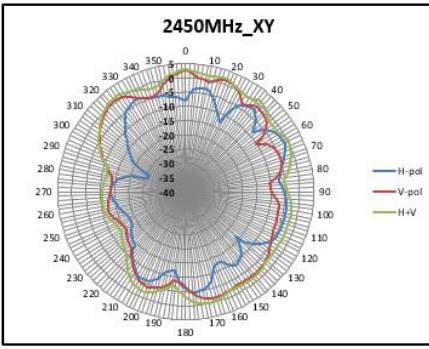
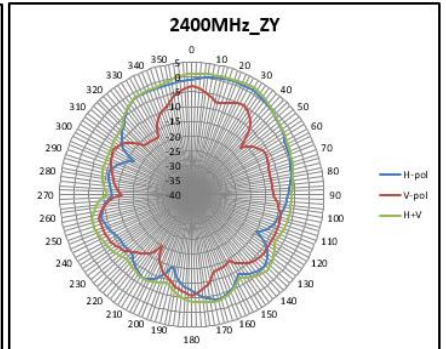
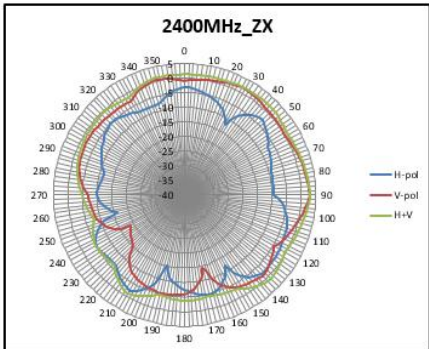
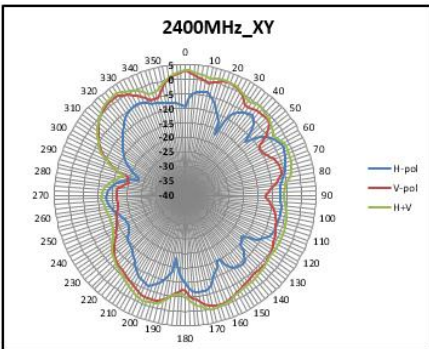

Project: U10C149	Date: 2019/11/28
Antenna Designer: Charles Lee	
Rev.: V1	Note:

7. Antenna Total Performance

Antenna	Frequency(MHz)	2400	2450	2500	5050	5150	5350	5725	5825
WIFI#1	Peak Gain	3.90	3.88	3.64	4.14	3.90	3.90	1.82	2.82
	Avg. Gain	-1.35	-1.11	-1.30	-1.29	-1.32	-1.19	-1.32	-1.49
	Efficiency%	73.34	77.45	74.15	74.27	73.76	76.01	73.74	70.96
WIFI#2	Peak Gain	3.87	3.97	3.41	3.74	4.15	4.84	4.76	4.78
	Avg. Gain	-1.29	-1.30	-1.24	-1.30	-1.11	-1.22	-1.31	-1.35
	Efficiency%	74.26	74.20	75.09	74.18	77.45	75.45	73.94	73.35
WIFI#3	Peak Gain	3.73	3.90	3.59	3.05	3.13	3.85	3.05	2.69
	Avg. Gain	-1.22	-1.30	-1.29	-1.32	-1.37	-1.28	-1.19	-1.14
	Efficiency%	75.58	74.15	74.22	73.77	72.90	74.46	76.11	76.84
WIFI#4	Peak Gain	3.08	3.04	2.58	3.28	3.47	3.59	3.42	2.60
	Avg. Gain	-1.48	-1.21	-1.42	-1.29	-1.26	-1.20	-1.21	-1.44
	Efficiency%	71.18	75.65	72.13	74.26	74.77	75.84	75.65	71.74



FOXCONN INTERCONNECT TECHNOLOGY LIMITED

包 裝 作 業 規 範

環保要求
符合 EPI12 規定

規範編號	TBD			保密等級	<input type="checkbox"/> 機密 <input type="checkbox"/> 密 <input checked="" type="checkbox"/> 一般				
適用客戶	UBEE	適用產品	ANTP2M2-CUB15-EH ANTP2M2-CUB16-EH ANTP2M2-CUB17-EH ANTP2M2-CUB18-EH	PAGE	1 / 4	REV.	X1	包裝類別	蜂巢隔板

修訂履歷

ECN No Rev.	頁 次							
	1	2	3	4	5	6	7	8
X1	/							

核定	審核	會 簽		制作單位	制作人
		生產單位	品保單位		
李瑞祺 2019/12/03	陳云岐 2019/12/03	姚日紅 2019/12/03	董銀娟 2019/12/03	ACE-FAS-ME	解文斌 2019/12/03



包裝作業規範

環保要求
符合 EPI12 規定

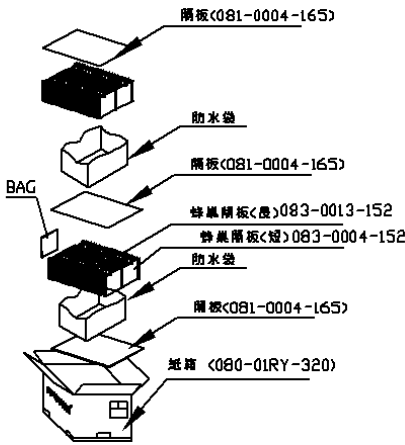
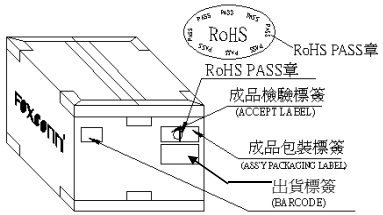
規範編號	TBD			保密等級	<input type="checkbox"/> 機密	<input type="checkbox"/> 密	<input checked="" type="checkbox"/> 一般				
適用客戶	UBEE	適用產品	ANTP2M2-CUB15-EH ANTP2M2-CUB16-EH ANTP2M2-CUB17-EH ANTP2M2-CUB18-EH	PAGE	2 / 4	REV.	X1				
				包裝類別	蜂巢隔板						
包裝作業圖示及說明				備 注							
<p>一：1.每20PCS產品用PE BAG 包裝起來，.將100PCS(5個PE BAG)包裝好的產品疊放在一起,放入隔板中.(圖示供參考)</p> 				<p>二：</p> <ol style="list-style-type: none"> 1.在外箱(080-02RZ-320)內放入隔板 (081-0004-165) 2.在外箱內放入防水袋 (080-0016-038) , 並敞開袋口. 3.分別放入蜂巢隔板 (083-0013-152) 3PCS,及蜂巢隔板 (083-0004-152) 11PCS,成蜂巢狀放入袋中,每1隔間內放入100PCS 產品. 4.包好防水袋,在上面放入隔板 (081-0004-165) ,再放1PC防水袋(080-0016-038),並敞開袋口. 5.如上重複3.4, 上下兩層各2000PCS,共4000PCS. 6.封好防水袋, 在頂層放1隔板 (081-0004-165) , 封箱. 7.封箱后,在外箱上貼上標籤. <p>如圖：</p> 							
<p>三：外箱標籤粘貼方式，具體的Barcode 要求依據出貨管制.</p> 				<p>1.標籤張貼位置及填寫注意事項,請參照生產管理作業標準: (THE STICKING POSITION OF LABEL AND THE POINTS FOR ATTENTION, 外裝瓦楞紙箱及標籤應用管理辦法(文件編號:P103-P01). REFER TO FILE: P103-P01)</p> <p>2.外箱封箱請依據ESH-KKG-003成品出貨之封箱作業標準文件, (HOW TO SEAL THE BOX, REFER TO FILE: ESH-KKG-003.)</p> <p>3.封後之外箱,在棧板上最高堆疊高度：5層, (THERE ARE FIVE STOREYS AT MOST ON THE PALLET AFTER SEALED BOX.)</p> <p>4.包裝標籤: (PACKAGING LABEL)</p> <p>FOXCONN®</p> <table border="1"> <tr><td>P/N: FOXCONN P/N</td></tr> <tr><td>C.P/N: CUSTOMER P/N #</td></tr> <tr><td>DATE: MM/DD/YYYY <input type="checkbox"/></td></tr> <tr><td>Q'TY: ___ PCS W'T: ___</td></tr> </table> <p>1.標籤中"#”表客戶版次, FOXCONN料號,客戶料號及版次依計劃表為準.;如CISCO無鉛料號, 版次後加*; 2.標籤中MM/DD/YYYY表示: 生產月份/日期/年份 (例如: 12/13/2009) 3.標籤中"□”表UL 認可製造地代碼. 例如: B: 龍華; T:台灣; K:崑山 H:淮安 4.Q'TY:裝箱數量, 依包規; 零數箱依實際為準. 5.W'T:產品標重, 依系統為準. 備注: 如產品出國外, 標籤需帶"Made in china".</p> <p>* 若出貨為成品時,每箱實重應以實測重量為準.</p>				P/N: FOXCONN P/N	C.P/N: CUSTOMER P/N #	DATE: MM/DD/YYYY <input type="checkbox"/>	Q'TY: ___ PCS W'T: ___
P/N: FOXCONN P/N											
C.P/N: CUSTOMER P/N #											
DATE: MM/DD/YYYY <input type="checkbox"/>											
Q'TY: ___ PCS W'T: ___											

備注:



包裝作業規範

環保要求
符合 EPII2 規定

規範編號	TBD			保密等級	<input type="checkbox"/> 機密	<input type="checkbox"/> 密	<input checked="" type="checkbox"/> 一般
適用客戶	UBEE	適用產品	ANTP2M2-CUB15-EH ANTP2M2-CUB16-EH ANTP2M2-CUB17-EH ANTP2M2-CUB18-EH	PAGE	3/4	REV.	X1
包裝作業圖示及說明				包裝類別	蜂巢隔板		
				備 注			
				<ol style="list-style-type: none"> 木棧板上放滿後, 在4個角各放1PC角板, 之後於四周纏繞打包膜; 打包膜至少纏繞 3 層.(打包膜一定要從棧板底部一直纏繞到貨物頂部) 棧板尺寸為1.2M×1.0M×0.12M, 0.12M為支承木塊的高度. 棧板必須為木質的, 包括原木和膠合木. 棧板連同貨物堆積高度不大於1.7M. 木棧板上每層最多擺放8箱, 每棧板最多放5層, 共40箱。(棧板連同貨物堆積高度不大於1.7M)。 <p>***本產品, 制程之原物料/零件必須符合EPII2環境管理物質規定.</p>			

備注: "包裝作業圖示及說明"欄位內應包括但不限於: 整箱包裝模式設計、整棧板包裝模式設計、可替代包裝模式設計等。



FOXCONN INTERCONNECT TECHNOLOGY LIMITED

包 裝 作 業 規 範

環保要求
符合 EPI12 規定

規範編號				TBD									
適用料號				ANTP2M2-CUB15-EH ANTP2M2-CUB16-EH ANTP2M2-CUB17-EH ANTP2M2-CUB18-EH			包裝容量			重 量 (Kg)			
材料名稱 (替代材料名稱)				料號 (替代材料料號)	淨重	用量	產品型號	最內層包裝產品數量	每箱最內層包裝數	每箱包裝產品總數量	每PCS淨重	每箱淨重	每箱毛重
外 箱(576*450*360mm)				080-02RZ-320	1.79	1	ANTP2M2-CUB15-EH	20	200	4000	/	/	/
隔板				081-0004-165	0.08	3	ANTP2M2-CUB16-EH	20	200	4000	/	/	/
防水袋				080-0016-038	0.06	2	ANTP2M2-CUB17-EH	20	200	4000	/	/	/
封箱膠帶				090-0060-510	N/A	/	ANTP2M2-CUB18-EH	20	200	4000	/	/	/
蜂巢隔板(長)				083-0013-152	0.05021	6							
蜂巢隔板(短)				083-0004-152	0.039	22							
成品包裝標籤				080-1011-319	0.0006	1							
內箱BARCODE				080-2019-319	N/A	1							
外箱BARCODE				080-2019-319	N/A	1							
PE袋				084-0001-8957	N/A	200							

備注:
 1. 外箱的長*寬*高是520mm*400mm*300mm
 2. 本產品,制程之原物料/零件必須符合EPI12環境管理物質規定
 3. 實際重量以出貨為準(即以TIPTOP系統中標重為準)

說明:
 1) 包裝箱/袋上的安規標示要求需在包裝作業規範上注明,如張貼安規標籤,需注明張貼標籤類型/數量/張貼位置.
 2) 當存在可用於臨時狀態的替代材料時,應於上表中予以界定.