

FCC Test Report

Report No.: RF191105E04-1

FCC ID: XCNUBC1326

Test Model: UBC1326

Received Date: July 09, 2019

Test Date: Nov. 11 2019 to Feb. 07, 2020

Issued Date: Mar. 06, 2020

Applicant: Ubee Interactive Corp.

Address: 10F-1, No. 5, Taiyuan 1st St. Zhubei City, Hsinchu County 302, Taiwan ,
R.O.C.

Issued By: Bureau Veritas Consumer Products Services (H.K.) Ltd., Taoyuan Branch
Hsin Chu Laboratory

Lab Address: E-2, No.1, Li Hsin 1st Road, Hsinchu Science Park, Hsinchu City 300,
Taiwan

Test Location: E-2, No.1, Li Hsin 1st Road, Hsinchu Science Park, Hsinchu City 300,
Taiwan

**FCC Registration /
Designation Number:** 723255 / TW2022



This report is for your exclusive use. Any copying or replication of this report to or for any other person or entity, or use of our name or trademark, is permitted only with our prior written permission. This report sets forth our findings solely with respect to the test samples identified herein. The results set forth in this report are not indicative or representative of the quality or characteristics of the lot from which a test sample was taken or any similar or identical product unless specifically and expressly noted. Our report includes all of the tests requested by you and the results thereof based upon the information that you provided to us. You have 60 days from date of issuance of this report to notify us of any material error or omission caused by our negligence, provided, however, that such notice shall be in writing and shall specifically address the issue you wish to raise. A failure to raise such issue within the prescribed time shall constitute your unqualified acceptance of the completeness of this report, the tests conducted and the correctness of the report contents. Unless specific mention, the uncertainty of measurement has been explicitly taken into account to declare the compliance or non-compliance to the specification. The report must not be used by the client to claim product certification, approval, or endorsement by TAF or any government agencies.

Table of Contents

Release Control Record	4
1 Certificate of Conformity	5
2 Summary of Test Results	6
2.1 Measurement Uncertainty	6
2.2 Modification Record	6
3 General Information	7
3.1 General Description of EUT	7
3.2 Description of Test Modes	9
3.2.1 Test Mode Applicability and Tested Channel Detail	10
3.3 Duty Cycle of Test Signal	13
3.4 Description of Support Units	14
3.4.1 Configuration of System under Test	15
3.5 General Description of Applied Standard and References	16
4 Test Types and Results	17
4.1 Radiated Emission and Bandedge Measurement	17
4.1.1 Limits of Radiated Emission and Bandedge Measurement	17
4.1.2 Test Instruments	18
4.1.3 Test Procedure	21
4.1.4 Deviation from Test Standard	21
4.1.5 Test Setup	22
4.1.6 EUT Operating Condition	23
4.1.7 Test Results	24
4.2 Conducted Emission Measurement	44
4.2.1 Limits of Conducted Emission Measurement	44
4.2.2 Test Instruments	44
4.2.3 Test Procedure	45
4.2.4 Deviation from Test Standard	45
4.2.5 Test Setup	45
4.2.6 EUT Operating Condition	45
4.2.7 Test Results	46
4.3 Transmit Power Measurement	48
4.3.1 Limits of Transmit Power Measurement	48
4.3.2 Test Setup	48
4.3.3 Test Instruments	48
4.3.4 Test Procedure	48
4.3.5 Deviation from Test Standard	49
4.3.6 EUT Operating Condition	49
4.3.7 Test Result	50
4.4 Occupied Bandwidth Measurement	54
4.4.1 Test Setup	54
4.4.2 Test Instruments	54
4.4.3 Test Procedure	54
4.4.4 Test Results	55
4.5 Peak Power Spectral Density Measurement	61
4.5.1 Limits of Peak Power Spectral Density Measurement	61
4.5.2 Test Setup	61
4.5.3 Test Instruments	61
4.5.4 Test Procedure	61
4.5.5 Deviation from Test Standard	62
4.5.6 EUT Operating Condition	62
4.5.7 Test Results	63
4.6 Frequency Stability Measurement	69
4.6.1 Limits of Frequency Stability Measurement	69

4.6.2 Test Setup.....	69
4.6.3 Test Instruments	69
4.6.4 Test Procedure	69
4.6.5 Deviation from Test Standard	69
4.6.6 EUT Operating Condition	69
4.6.7 Test Results	70
4.7 6dB Bandwidth Measurement	71
4.7.1 Limits of 6dB Bandwidth Measurement.....	71
4.7.2 Test Setup.....	71
4.7.3 Test Instruments	71
4.7.4 Test Procedure	71
4.7.5 Deviation from Test Standard	71
4.7.6 EUT Operating Condition	71
4.7.7 Test Results	72
5 Pictures of Test Arrangements.....	74
Annex A- Radiated Out of Band Emission (OOBE) Measurement (For U-NII-3 band)	75
Appendix – Information of the Testing Laboratories	78

Release Control Record

Issue No.	Description	Date Issued
RF191105E04-1	Original release.	Mar. 06, 2020

1 Certificate of Conformity

Product: Wireless eMTA

Brand: Ubee

Test Model: UBC1326

Applicant: Ubee Interactive Corp.

Test Date: Nov. 11 2019 to Feb. 07, 2020

Standard: 47 CFR FCC Part 15, Subpart E (Section 15.407)
ANSI C63.10: 2013

The above equipment has been tested by **Bureau Veritas Consumer Products Services (H.K.) Ltd., Taoyuan Branch**, and found compliance with the requirement of the above standards. The test record, data evaluation & Equipment Under Test (EUT) configurations represented herein are true and accurate accounts of the measurements of the sample's EMC characteristics under the conditions specified in this report.

Prepared by :  , **Date:** Mar. 06, 2020
Claire Kuan / Specialist

Approved by :  , **Date:** Mar. 06, 2020
Clark Lin / Technical Manager

2 Summary of Test Results

47 CFR FCC Part 15, Subpart E (Section 15.407)			
FCC Clause	Test Item	Result	Remarks
15.407(b)(6)	AC Power Conducted Emissions	Pass	Meet the requirement of limit. Minimum passing margin is -14.54dB at 0.31016MHz.
15.407(b) (1/2/3/4(i/ii)/6)	Radiated Emissions & Band Edge Measurement*	Pass	Meet the requirement of limit. Minimum passing margin is -0.1dB at 5150.00MHz.
15.407(a)(1/2/3)	Max Average Transmit Power	Pass	Meet the requirement of limit.
---	Occupied Bandwidth Measurement	-	Reference only.
15.407(a)(1/2/3)	Peak Power Spectral Density	Pass	Meet the requirement of limit.
15.407(e)	6dB bandwidth	Pass	Meet the requirement of limit. (U-NII-3 Band only)
15.407(g)	Frequency Stability	Pass	Meet the requirement of limit.
15.203	Antenna Requirement	Pass	Antenna connector is i-pex (MHF) not a standard connector.

*For U-NII-3 band compliance with rule part 15.407(b)(4)(i), the OOB test plots were recorded in Annex A.

Note:

Determining compliance based on the results of the compliance measurement, not taking into account measurement instrumentation uncertainty.

2.1 Measurement Uncertainty

Where relevant, the following measurement uncertainty levels have been estimated for tests performed on the EUT as specified in CISPR 16-4-2:

Measurement	Frequency	Expanded Uncertainty (k=2) (\pm)
Conducted Emissions at mains ports	150kHz ~ 30MHz	1.8 dB
Radiated Emissions up to 1 GHz	9kHz ~ 30MHz	3.0 dB
	30MHz ~ 1GHz	4.9 dB
Radiated Emissions above 1 GHz	1GHz ~ 6GHz	5.1 dB
	6GHz ~ 18GHz	4.9 dB
	18GHz ~ 40GHz	5.2 dB

2.2 Modification Record

There were no modifications required for compliance.

3 General Information

3.1 General Description of EUT

Product	Wireless eMTA
Brand	Ubee
Test Model	UBC1326
Power Supply Rating	12Vdc from power adapter
Modulation Type	CCK, DQPSK, DBPSK for DSSS 64QAM, 16QAM, QPSK, BPSK for OFDM 256QAM for OFDM in 11ac mode and VHT20/40 in 2.4GHz mode 1024QAM for OFDMA in 11ax HE mode
Modulation Technology	DSSS, OFDM, OFDMA
Transfer Rate	802.11b: up to 11Mbps 802.11a/g: up to 54Mbps 802.11n: up to 600Mbps 802.11ac: up to 1733.3Mbps 802.11ax: up to 2401.9Mbps
Operating Frequency	2.4GHz: 2.412 ~ 2.462GHz 5GHz: 5.18~ 5.24GHz, 5.745 ~ 5.825GHz
Number of Channel	2.4GHz: 802.11b, 802.11g, 802.11n (HT20), VHT20, 802.11ax (HE20): 11 802.11n (HT40), VHT40, 802.11ax (HE40): 7 5GHz: 802.11a, 802.11n (HT20), 802.11ac (VHT20), 802.11ax (HE20): 9 802.11n (HT40), 802.11ac (VHT40), 802.11ax (HE40): 4 802.11ac (VHT80), 802.11ax (HE80): 2
Output Power	Non-Beamforming Mode: 2.4GHz: 985.542mW 5.18 ~ 5.24GHz: 759.186mW 5.745 ~ 5.825GHz: 977.737mW Beamforming Mode: 2.4GHz: 403.108mW 5.18 ~ 5.24GHz: 373.518mW 5.745 ~ 5.825GHz: 382.095mW
Antenna Type	Refer to Note
Antenna Connector	Refer to Note
Accessory Device	NA
Data Cable Supplied	NA

Note:

1. Simultaneously transmission condition.

Condition	Technology	
1	WLAN (2.4GHz)	WLAN (5GHz)

Note: The emission of the simultaneous operation has been evaluated and no non-compliance was found.

2. The EUT power needs to be supplied from a power adapter, the information is as below table:

No.	Brand	Model No.	Spec.
1	APD	WA-36N12FU	Input: 100-240Vac, 0.9A, 50-60Hz Output: 12Vdc, 3A DC Output cable: Unshielded, 1.8m

3. The antennas provided to the EUT, please refer to the following table:

Antenna NO.	RF Chain NO.	Antenna Net Gain(dBi)	Frequency range	Antenna Type	Connector Type	Cable Length
WiFi 1	Chain1/2	3.9/4.14	2.4GHz/5GHz	PCB	i-pex(MHF)	155mm
WiFi 2	Chain2/1	3.97/4.84	2.4GHz/5GHz	PCB	i-pex(MHF)	87mm
WiFi 3	Chain0/3	3.9/3.85	2.4GHz/5GHz	PCB	i-pex(MHF)	75mm
WiFi 4	Chain3/0	3.08/3.59	2.4GHz/5GHz	PCB	i-pex(MHF)	100mm

4. The EUT incorporates a MIMO function.

2.4GHz Band		
MODULATION MODE	TX & RX CONFIGURATION	
802.11b	4TX	4RX
802.11g	4TX	4RX
802.11n (HT20)	4TX	4RX
802.11n (HT40)	4TX	4RX
VHT20	4TX	4RX
VHT40	4TX	4RX
802.11ax (HE20)	4TX	4RX
802.11ax (HE40)	4TX	4RX
5GHz Band		
MODULATION MODE	TX & RX CONFIGURATION	
802.11a	4TX	4RX
802.11n (HT20)	4TX	4RX
802.11n (HT40)	4TX	4RX
802.11ac (VHT20)	4TX	4RX
802.11ac (VHT40)	4TX	4RX
802.11ac (VHT80)	4TX	4RX
802.11ax (HE20)	4TX	4RX
802.11ax (HE40)	4TX	4RX
802.11ax (HE80)	4TX	4RX

Note:

1. All of modulation mode support beamforming function except 802.11a/b/g modulation mode.
2. The EUT support Beamforming and non-beamforming mode, therefore both mode were investigated and the worst case scenario was identified. The worst case data were presented in test report.
3. The modulation and bandwidth are similar for 802.11n mode for 20MHz (40MHz), 802.11ac mode for 20MHz (40MHz, 80MHz) and 802.11ax mode for 20MHz (40MHz, 80MHz), therefore the manufacturer will control the 802.11n/ac mode power as same or lower than 802.11ax and investigated worst case to representative mode in test report. (Final test mode refer section 3.2.1)

5. The above EUT information is declared by manufacturer and for more detailed features description, please refers to the manufacturer's specifications or user's manual.

3.2 Description of Test Modes

FOR 5180 ~ 5240MHz

4 channels are provided for 802.11a, 802.11n (HT20), 802.11ac (VHT20), 802.11ax (HE20):

Channel	Frequency	Channel	Frequency
36	5180 MHz	44	5220 MHz
40	5200 MHz	48	5240 MHz

2 channels are provided for 802.11n (HT40), 802.11ac (VHT40), 802.11ax (HE40):

Channel	Frequency	Channel	Frequency
38	5190 MHz	46	5230 MHz

1 channel is provided for 802.11ac (VHT80), 802.11ax (HE80):

Channel	Frequency
42	5210 MHz

FOR 5745 ~ 5825MHz:

5 channels are provided for 802.11a, 802.11n (HT20), 802.11ac (VHT20), 802.11ax (HE20):

Channel	Frequency	Channel	Frequency
149	5745 MHz	161	5805 MHz
153	5765 MHz	165	5825 MHz
157	5785 MHz		

2 channels are provided for 802.11n (HT40), 802.11ac (VHT40), 802.11ax (HE40):

Channel	Frequency	Channel	Frequency
151	5755 MHz	159	5795 MHz

1 channel is provided for 802.11ac (VHT80), 802.11ax (HE80):

Channel	Frequency
155	5775 MHz

3.2.1 Test Mode Applicability and Tested Channel Detail

EUT Configure Mode	Applicable To				Description
	RE \geq 1G	RE<1G	PLC	APCM	
-	√	√	√	√	-

Where **RE \geq 1G**: Radiated Emission above 1GHz **RE<1G**: Radiated Emission below 1GHz
PLC: Power Line Conducted Emission **APCM**: Antenna Port Conducted Measurement

Radiated Emission Test (Above 1GHz):

- Pre-Scan has been conducted to determine the worst-case mode from all possible combinations between available modulations, data rates and antenna ports (if EUT with antenna diversity architecture).
- Following channel(s) was (were) selected for the final test as listed below.

Non-Beamforming Mode						
Mode	FREQ. Band (MHz)	Available Channel	Tested Channel	Modulation Technology	Modulation Type	Data Rate Parameter
802.11a	5180-5240	36 to 48	36, 40, 48	OFDM	BPSK	6Mb/s
802.11ax (HE20)		36 to 48	36, 40, 48	OFDMA	BPSK	MCS0
802.11ax (HE40)		38 to 46	38, 46	OFDMA	BPSK	MCS0
802.11ax (HE80)		42	42	OFDMA	BPSK	MCS0
802.11a	5745-5825	149 to 165	149, 157, 165	OFDM	BPSK	6Mb/s
802.11ax (HE20)		149 to 165	149, 157, 165	OFDMA	BPSK	MCS0
802.11ax (HE40)		151 to 159	151, 159	OFDMA	BPSK	MCS0
802.11ax (HE80)		155	155	OFDMA	BPSK	MCS0

Radiated Emission Test (Below 1GHz):

- Pre-Scan has been conducted to determine the worst-case mode from all possible combinations between available modulations, data rates and antenna ports (if EUT with antenna diversity architecture).
- Following channel(s) was (were) selected for the final test as listed below.

Non-Beamforming Mode						
Mode	FREQ. Band (MHz)	Available Channel	Tested Channel	Modulation Technology	Modulation Type	Data Rate Parameter
802.11ax (HE40)	5180-5240 5745-5825	38 to 46 151 to 159	151	OFDMA	BPSK	MCS0

Power Line Conducted Emission Test:

- Pre-Scan has been conducted to determine the worst-case mode from all possible combinations between available modulations, data rates and antenna ports (if EUT with antenna diversity architecture).
- Following channel(s) was (were) selected for the final test as listed below.

Non-Beamforming Mode						
Mode	FREQ. Band (MHz)	Available Channel	Tested Channel	Modulation Technology	Modulation Type	Data Rate Parameter
802.11ax (HE40)	5180-5240 5745-5825	38 to 46 151 to 159	151	OFDMA	BPSK	MCS0

Antenna Port Conducted Measurement:

- This item includes all test value of each mode, but only includes spectrum plot of worst value of each mode.
- Pre-Scan has been conducted to determine the worst-case mode from all possible combinations between available modulations, data rates and antenna ports (if EUT with antenna diversity architecture).
- Following channel(s) was (were) selected for the final test as listed below.

Non-Beamforming Mode						
Mode	FREQ. Band (MHz)	Available Channel	Tested Channel	Modulation Technology	Modulation Type	Data Rate Parameter
802.11a	5180-5240	36 to 48	36, 40, 48	OFDM	BPSK	6Mb/s
802.11ac (VHT20) (Output power only)		36 to 48	36, 40, 48	OFDM	BPSK	MCS0
802.11ac (VHT40) (Output power only)		38 to 46	38, 46	OFDM	BPSK	MCS0
802.11ac (VHT80) (Output power only)		42	42	OFDM	BPSK	MCS0
802.11ax (HE20)		36 to 48	36, 40, 48	OFDMA	BPSK	MCS0
802.11ax (HE40)		38 to 46	38, 46	OFDMA	BPSK	MCS0
802.11ax (HE80)		42	42	OFDMA	BPSK	MCS0
802.11a		5745-5825	149 to 165	149, 157, 165	OFDM	BPSK
802.11ac (VHT20) (Output power only)	149 to 165		149, 157, 165	OFDM	BPSK	MCS0
802.11ac (VHT40) (Output power only)	151 to 159		151, 159	OFDM	BPSK	MCS0
802.11ac (VHT80) (Output power only)	155		155	OFDM	BPSK	MCS0
802.11ax (HE20)	149 to 165		149, 157, 165	OFDMA	BPSK	MCS0
802.11ax (HE40)	151 to 159		151, 159	OFDMA	BPSK	MCS0
802.11ax (HE80)	155		155	OFDMA	BPSK	MCS0

Beamforming Mode (output power only)						
Mode	FREQ. Band (MHz)	Available Channel	Tested Channel	Modulation Technology	Modulation Type	Data Rate Parameter
802.11ac (VHT20)	5180-5240	36 to 48	36, 40, 48	OFDM	BPSK	MCS0
802.11ac (VHT40)		38 to 46	38, 46	OFDM	BPSK	MCS0
802.11ac (VHT80)		42	42	OFDM	BPSK	MCS0
802.11ax (HE20)		36 to 48	36, 40, 48	OFDMA	BPSK	MCS0
802.11ax (HE40)		38 to 46	38, 46	OFDMA	BPSK	MCS0
802.11ax (HE80)		42	42	OFDMA	BPSK	MCS0
802.11ac (VHT20)	5745-5825	149 to 165	149, 157, 165	OFDM	BPSK	MCS0
802.11ac (VHT40)		151 to 159	151, 159	OFDM	BPSK	MCS0
802.11ac (VHT80)		155	155	OFDM	BPSK	MCS0
802.11ax (HE20)		149 to 165	149, 157, 165	OFDMA	BPSK	MCS0
802.11ax (HE40)		151 to 159	151, 159	OFDMA	BPSK	MCS0
802.11ax (HE80)		155	155	OFDMA	BPSK	MCS0

Test Condition:

Applicable To	Environmental Conditions	Input Power	Tested By
RE≥1G	25deg. C, 75%RH	120Vac, 60Hz	Gary Cheng
RE<1G	24deg. C, 57%RH	120Vac, 60Hz	Jeff Lee
PLC	25deg. C, 75%RH	120Vac, 60Hz	Kevin Ko
APCM	25deg. C, 60%RH	120Vac, 60Hz	Jyunchun Lin

3.3 Duty Cycle of Test Signal

If duty cycle of test signal is $\geq 98\%$, duty factor is not required.
 If duty cycle of test signal is $< 98\%$, duty factor shall be considered.

802.11a: Duty cycle = 2.063 ms/2.095 ms = 0.985

802.11ax (HE20): Duty cycle = 1.145 ms/1.177 ms = 0.973, Duty factor = $10 * \log(1/\text{Duty cycle}) = 0.12$

802.11ax (HE40): Duty cycle = 0.772 ms/0.803 ms = 0.961, Duty factor = $10 * \log(1/\text{Duty cycle}) = 0.17$

802.11ax (HE80): Duty cycle = 0.401 ms/0.433 ms = 0.926, Duty factor = $10 * \log(1/\text{Duty cycle}) = 0.33$

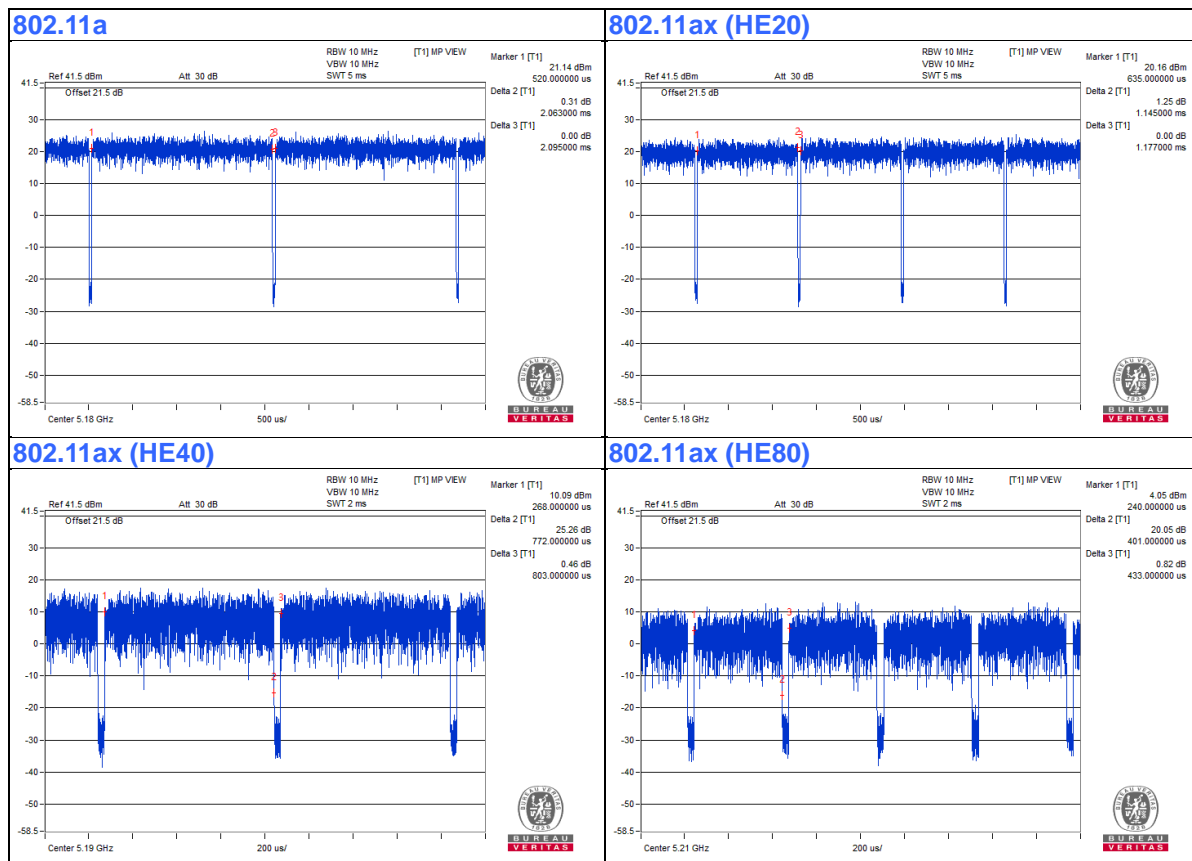

3.4 Description of Support Units

The EUT has been tested as an independent unit together with other necessary accessories or support units. The following support units or accessories were used to form a representative test configuration during the tests.

ID	Product	Brand	Model No.	Serial No.	FCC ID	Remarks
A.	Telephone	WONDER	WD-303	7C17KA04011	N/A	Provided by Lab
B.	Laptop	DELL	E5430	HYV4VY1	FCC DoC	Provided by Lab
C.	Laptop	Lenovo	81A4	YD02YN22	PD93165NGU	Provided by Lab
D.	USB Dongle	Sandisk	64GB	NA	NA	Supplied by client

Note:

1. All power cords of the above support units are non-shielded (1.8m).

ID	Descriptions	Qty.	Length (m)	Shielding (Yes/No)	Cores (Qty.)	Remarks
1.	DC Cable	1	1.8	No	0	Supplied by client
2.	RJ-11 Cable	1	10	No	0	Provided by Lab
3.	RJ-45 Cable	1	10	No	0	Provided by Lab
4.	RJ-45 Cable	1	10	No	0	Provided by Lab
5.	Coaxial Cable	1	10	Yes	0	Provided by Lab
6.	Type C to Type A USB Cable	1	0.06	Yes	0	Provided by Lab

3.4.1 Configuration of System under Test

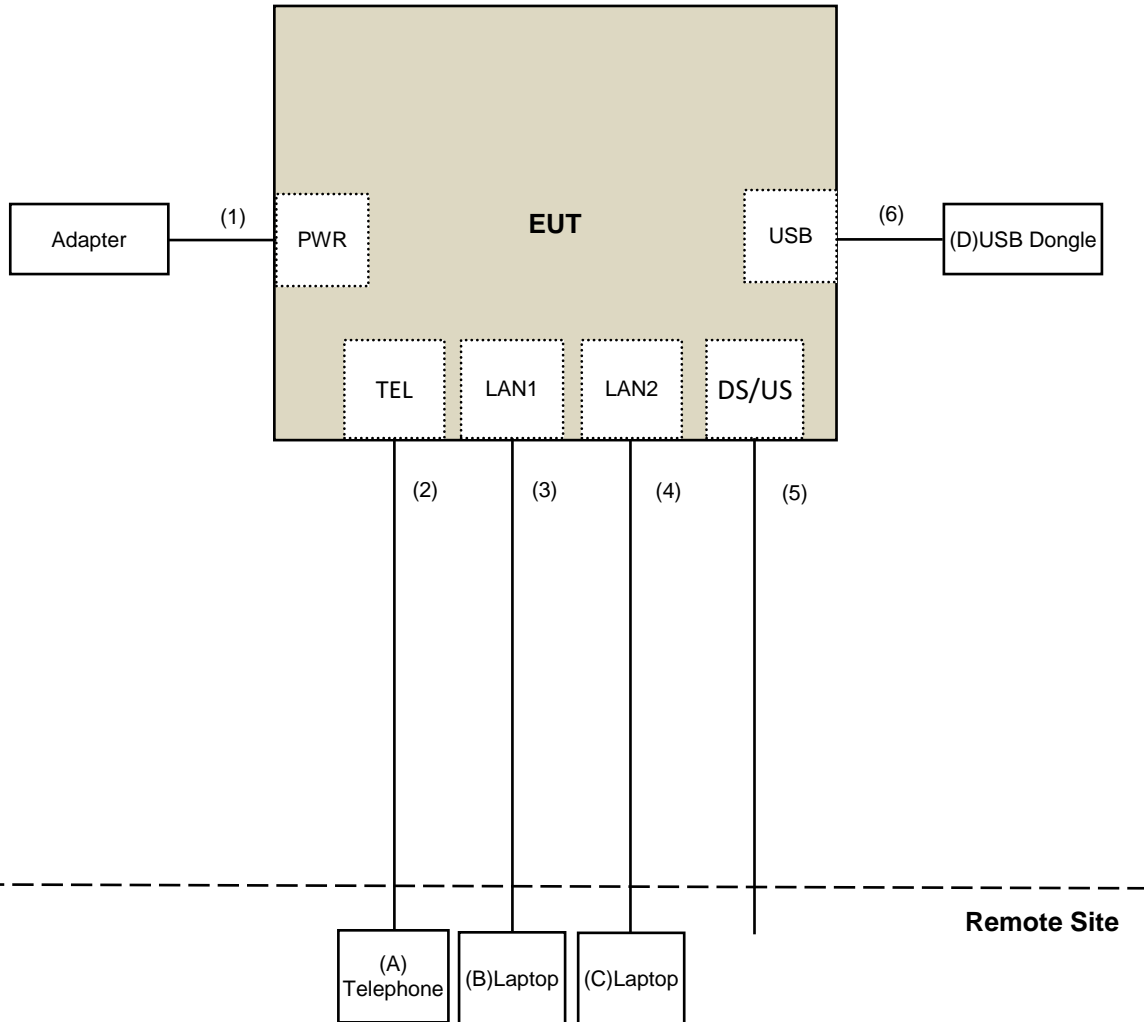

3.5 General Description of Applied Standard and References

The EUT is a RF Product. According to the specifications of the manufacturer, it must comply with the requirements of the following standards and and references:

Test Standard:

FCC Part 15, Subpart E (15.407)

ANSI C63.10-2013

All test items have been performed and recorded as per the above standards.

References Test Guidance:

KDB 789033 D02 General UNII Test Procedures New Rules v02r01

KDB 662911 D01 Multiple Transmitter Output v02r01

All test items have been performed as a reference to the above KDB test guidance.

4 Test Types and Results

4.1 Radiated Emission and Bandedge Measurement

4.1.1 Limits of Radiated Emission and Bandedge Measurement

Radiated emissions which fall in the restricted bands must comply with the radiated emission limits specified as below table.

Frequencies (MHz)	Field Strength (microvolts/meter)	Measurement Distance (meters)
0.009 ~ 0.490	2400/F(kHz)	300
0.490 ~ 1.705	24000/F(kHz)	30
1.705 ~ 30.0	30	30
30 ~ 88	100	3
88 ~ 216	150	3
216 ~ 960	200	3
Above 960	500	3

NOTE:

1. The lower limit shall apply at the transition frequencies.
2. Emission level (dBuV/m) = 20 log Emission level (uV/m).
3. For frequencies above 1000MHz, the field strength limits are based on average detector, however, the peak field strength of any emission shall not exceed the maximum permitted average limits, specified above by more than 20dB under any condition of modulation.

Limits of unwanted emission out of the restricted bands

Applicable To		Limit	
789033 D02 General UNII Test Procedure New Rules v02r01		Field Strength at 3m	
		PK:74 (dBuV/m)	AV:54 (dBuV/m)
Frequency Band	Applicable To	EIRP Limit	Equivalent Field Strength at 3m
5150~5250 MHz	15.407(b)(1)	PK:-27 (dBm/MHz)	PK:68.2(dBuV/m)
5250~5350 MHz	15.407(b)(2)		
5470~5725 MHz	15.407(b)(3)		
5725~5850 MHz	<input checked="" type="checkbox"/> 15.407(b)(4)(i)	PK:-27 (dBm/MHz) ^{*1} PK:10 (dBm/MHz) ^{*2} PK:15.6 (dBm/MHz) ^{*3} PK:27 (dBm/MHz) ^{*4}	PK: 68.2(dBuV/m) ^{*1} PK:105.2 (dBuV/m) ^{*2} PK: 110.8(dBuV/m) ^{*3} PK:122.2 (dBuV/m) ^{*4}
	<input type="checkbox"/> 15.407(b)(4)(ii)	Emission limits in section 15.247(d)	
^{*1} beyond 75 MHz or more above of the band edge. ^{*3} below the band edge increasing linearly to a level of 15.6 dBm/MHz at 5 MHz above.		^{*2} below the band edge increasing linearly to 10 dBm/MHz at 25 MHz above. ^{*4} from 5 MHz above or below the band edge increasing linearly to a level of 27 dBm/MHz at the band edge.	

Note:

The following formula is used to convert the equipment isotropic radiated power (eirp) to field strength:

$$E = \frac{1000000\sqrt{30P}}{3} \mu\text{V/m, where P is the eirp (Watts).}$$

4.1.2 Test Instruments

For OOB test:

DESCRIPTION & MANUFACTURER	MODEL NO.	SERIAL NO.	CALIBRATED DATE	CALIBRATED UNTIL
Test Receiver Keysight	N9038A	MY54450088	July 03, 2019	July 02, 2020
Horn_Antenna SCHWARZBECK	BBHA 9120D	9120D-783	Nov. 24, 2019	Nov. 23, 2020
Pre-Amplifier EMCI	EMC12630SE	980385	Aug. 15, 2019	Aug. 14, 2020
RF Cable	EMC104-SM-SM-1200	160923	Jan. 28, 2019	Jan. 27, 2020
RF Cable	104 RF cable	131215	Jan. 10, 2019	Jan. 09, 2020
RF Cable	EMC104-SM-SM-6000	180418	May 03, 2019	May 02, 2020
Pre-Amplifier EMCI	EMC184045SE	980387	Jan. 28, 2019	Jan. 27, 2020
Horn_Antenna SCHWARZBECK	BBHA 9170	BBHA9170519	Nov. 24, 2019	Nov. 23, 2020
RF Cable	EMC102-KM-KM-1200	160924	Jan. 28, 2019	Jan. 27, 2020
RF Cable	EMC102-KM-KM-1200	160925	Jan. 28, 2019	Jan. 27, 2020
Software	ADT_Radiated_V8.7.08	NA	NA	NA
Boresight Antenna Tower & Turn Table Max-Full	MF-7802BS	MF780208530	NA	NA

Note:

1. The calibration interval of the above test instruments is 12 months and the calibrations are traceable to NML/ROC and NIST/USA.
2. The test was performed in 966 Chamber No. 4.
3. Loop antenna was used for all emissions below 30 MHz.
4. Tested Date: Dec. 28, 2019

For radiated emission test:

DESCRIPTION & MANUFACTURER	MODEL NO.	SERIAL NO.	CALIBRATED DATE	CALIBRATED UNTIL
Test Receiver Keysight	N9038A	MY54450088	July 03, 2019	July 02, 2020
Pre-Amplifier EMCI	EMC001340	980142	May 30, 2019	May 29, 2020
Loop Antenna Electro-Metrics	EM-6879	264	Jan. 22, 2019	Jan. 21, 2020
RF Cable	NA	LOOPCAB-001	Jan. 14, 2019	Jan. 13, 2020
RF Cable	NA	LOOPCAB-002	Jan. 14, 2019	Jan. 13, 2020
Pre-Amplifier Mini-Circuits	ZFL-1000VH2B	AMP-ZFL-01	Oct. 23, 2019	Oct. 22, 2020
Trilog Broadband Antenna SCHWARZBECK	VULB 9168	9168-406	Nov. 11, 2019	Nov. 10, 2020
RF Cable	8D	966-4-1	Mar. 19, 2019	Mar. 18, 2020
RF Cable	8D	966-4-2	Mar. 19, 2019	Mar. 18, 2020
RF Cable	8D	966-4-3	Mar. 19, 2019	Mar. 18, 2020
Fixed attenuator Mini-Circuits	UNAT-5+	PAD-3m-4-01	Sep. 26, 2019	Sep. 25, 2020

Note:

1. The calibration interval of the above test instruments is 12 months and the calibrations are traceable to NML/ROC and NIST/USA.
2. The test was performed in 966 Chamber No. 4.
3. Loop antenna was used for all emissions below 30 MHz.
4. Tested Date: Nov. 11, 2019

For other test items:

DESCRIPTION & MANUFACTURER	MODEL NO.	SERIAL NO.	CALIBRATED DATE	CALIBRATED UNTIL
Test Receiver Agilent	N9038A	MY51210202	Dec. 13, 2019	Dec. 12, 2020
Horn_Antenna SCHWARZBECK	BBHA 9120D	9120D-783	Nov. 24, 2019	Nov. 23, 2020
Pre-Amplifier EMCI	EMC12630SE	980385	Aug. 15, 2019	Aug. 14, 2020
RF Cable	EMC104-SM-SM-1200	160923	Jan. 15, 2020	Jan. 14, 2021
RF Cable	104 RF cable	131215	Jan. 09, 2020	Jan. 08, 2021
RF Cable	EMC104-SM-SM-6000	180418	May 03, 2019	May 02, 2020
Pre-Amplifier EMCI	EMC184045SE	980387	Jan. 15, 2020	Jan. 14, 2021
Horn_Antenna SCHWARZBECK	BBHA 9170	BBHA9170519	Nov. 24, 2019	Nov. 23, 2020
RF Cable	EMC102-KM-KM-1200	160924	Jan. 15, 2020	Jan. 14, 2021
RF Cable	EMC102-KM-KM-4500	181205	Aug. 26, 2019	Aug. 25, 2020
Software	ADT_Radiated_V8.7.08	NA	NA	NA
Boresight Antenna Tower & Turn Table Max-Full	MF-7802BS	MF780208530	NA	NA
Spectrum Analyzer R&S	FSV40	100964	June 04, 2019	June 03, 2020
Power meter Anritsu	ML2495A	1014008	May 13, 2019	May 12, 2020
Power sensor Anritsu	MA2411B	0917122	May 13, 2019	May 12, 2020
Fixed Attenuator Mini-Circuits	MDCS18N-10	MDCS18N-10-01	Apr. 15, 2019	Apr. 14, 2020
AC Power Source Extech Electronics	6205	1440452	NA	NA
Temperature & Humidity Chamber Giant Force	GTH-150-40-SP-AR	MAA0812-008	Jan. 16, 2020	Jan. 15, 2021
True RMS Clamp Meter FLUKE	325	31130711WS	May 21, 2019	May 20, 2020

Note:

1. The calibration interval of the above test instruments is 12 months and the calibrations are traceable to NML/ROC and NIST/USA.
2. The test was performed in 966 Chamber No. 4.
3. Loop antenna was used for all emissions below 30 MHz.
4. Tested Date: Feb. 05 to 07, 2020

4.1.3 Test Procedure

For Radiated emission below 30MHz

- a. The EUT was placed on the top of a rotating table 0.8 meters above the ground at a 3 meter chamber room. The table was rotated 360 degrees to determine the position of the highest radiation.
- b. The EUT was set 3 meters away from the interference-receiving antenna, which was mounted on the top of a variable-height antenna tower.
- c. Parallel, perpendicular, and ground-parallel orientations of the antenna are set to make the measurement.
- d. For each suspected emission, the EUT was arranged to its worst case and the rotatable table was turned from 0 degrees to 360 degrees to find the maximum reading.
- e. The test-receiver system was set to Quasi-Peak Detect Function and Specified Bandwidth with Maximum Hold Mode.

NOTE:

1. The resolution bandwidth and video bandwidth of test receiver/spectrum analyzer is 9kHz at frequency below 30MHz.

For Radiated emission above 30MHz

- a. The EUT was placed on the top of a rotating table 0.8 meters (for 30MHz ~ 1GHz) / 1.5 meters (for above 1GHz) above the ground at 3 meter chamber room for test. The table was rotated 360 degrees to determine the position of the highest radiation.
- b. The EUT was set 3 meters away from the interference-receiving antenna, which was mounted on the top of a variable-height antenna tower.
- c. The height of antenna is varied from one meter to four meters above the ground to determine the maximum value of the field strength. Both horizontal and vertical polarizations of the antenna are set to make the measurement.
- d. For each suspected emission, the EUT was arranged to its worst case and then the antenna was tuned to heights from 1 meter to 4 meters and the rotatable table was turned from 0 degrees to 360 degrees to find the maximum reading.
- e. The test-receiver system was set to quasi-peak detect function and specified bandwidth with maximum hold mode when the test frequency is below 1 GHz.
- f. The test-receiver system was set to peak and average detects function and specified bandwidth with maximum hold mode when the test frequency is above 1 GHz. If the peak reading value also meets average limit, measurement with the average detector is unnecessary.

Note:

1. The resolution bandwidth and video bandwidth of test receiver/spectrum analyzer is 120kHz for Quasi-peak detection (QP) at frequency below 1GHz.
2. The resolution bandwidth of test receiver/spectrum analyzer is 1 MHz and the video bandwidth is 3 MHz for Peak detection (PK) at frequency above 1GHz.
3. The resolution bandwidth of test receiver/spectrum analyzer is 1MHz and the video bandwidth is $\geq 1/T$ (Duty cycle $< 98\%$) or 10Hz (Duty cycle $\geq 98\%$) for Average detection (AV) at frequency above 1GHz.
4. All modes of operation were investigated and the worst-case emissions are reported.

4.1.4 Deviation from Test Standard

No deviation.

4.1.5 Test Setup

For Radiated emission below 30MHz

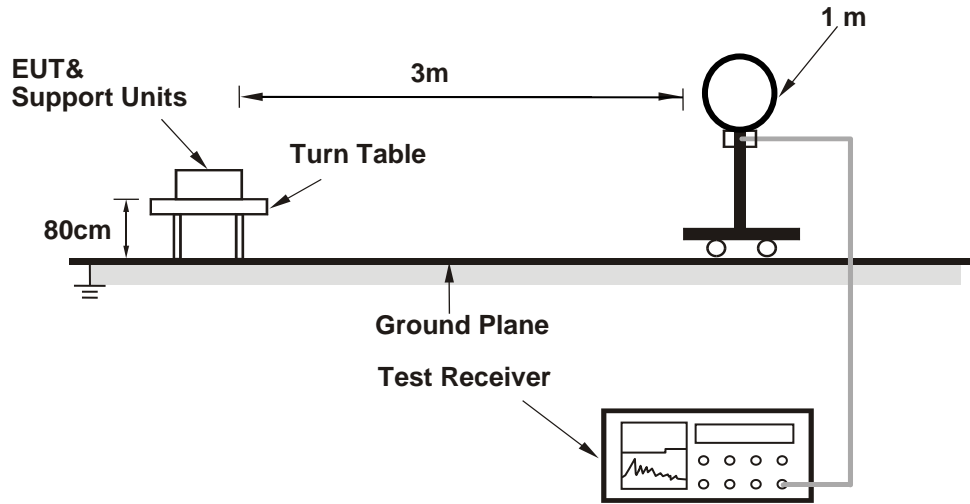

For Radiated emission 30MHz to 1GHz

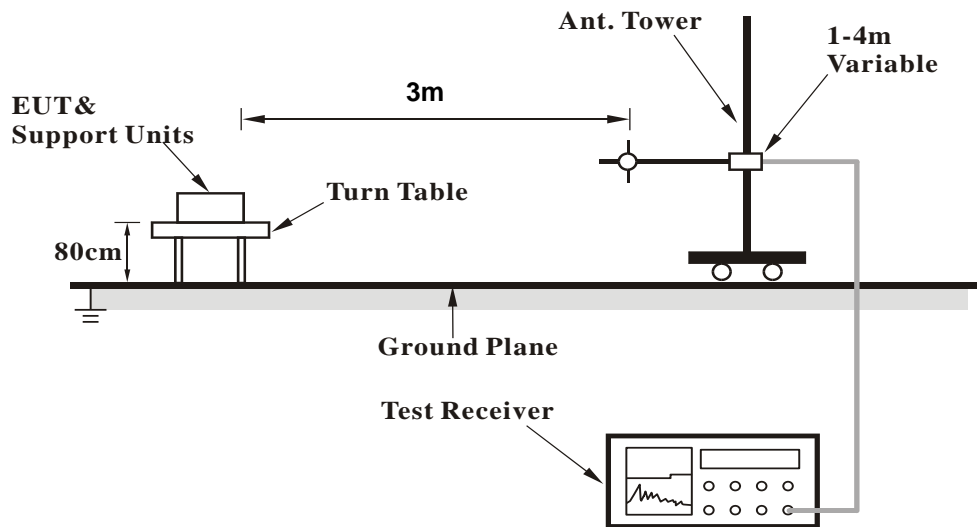

For Radiated emission above 1GHz

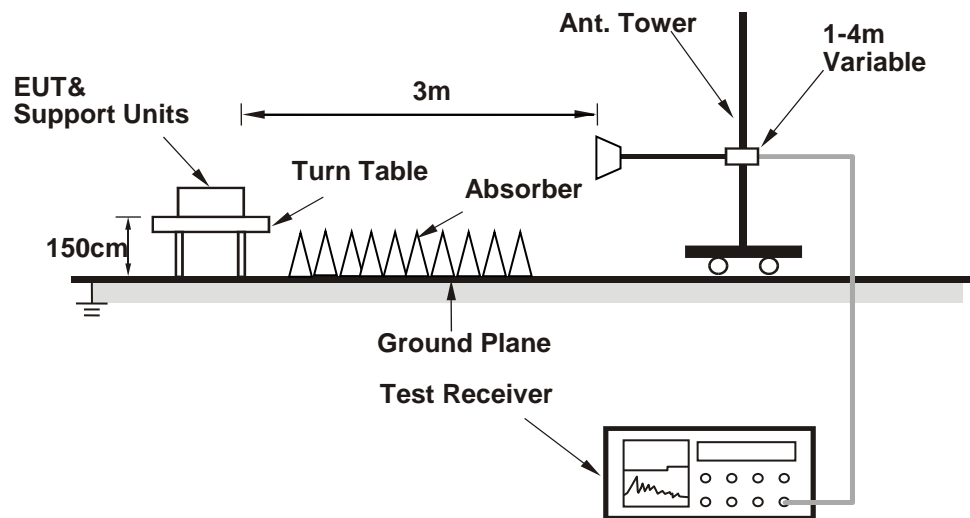

For the actual test configuration, please refer to the attached file (Test Setup Photo).

4.1.6 EUT Operating Condition

- a. Connected the EUT with the Laptop which is placed on remote site.
- b. Controlling software (Mtool v3.1.0.1) has been activated to set the EUT under transmission condition continuously at specific channel frequency.

4.1.7 Test Results

Above 1GHz Data:

802.11a

CHANNEL	TX Channel 36	DETECTOR FUNCTION	Peak (PK)
FREQUENCY RANGE	1GHz ~ 40GHz		Average (AV)

ANTENNA POLARITY & TEST DISTANCE: HORIZONTAL AT 3 M

NO.	FREQ. (MHz)	EMISSION LEVEL (dBuV/m)	LIMIT (dBuV/m)	MARGIN (dB)	ANTENNA HEIGHT (m)	TABLE ANGLE (Degree)	RAW VALUE (dBuV)	CORRECTION FACTOR (dB/m)
1	5150.00	72.0 PK	74.0	-2.0	1.92 H	163	68.9	3.1
2	5150.00	53.8 AV	54.0	-0.2	1.92 H	163	50.7	3.1
3	*5180.00	118.5 PK			1.92 H	163	115.4	3.1
4	*5180.00	108.5 AV			1.92 H	163	105.4	3.1
5	#10360.00	42.1 PK	68.2	-26.1	1.59 H	165	29.0	13.1
6	15540.00	49.4 PK	74.0	-24.6	2.04 H	254	35.9	13.5
7	15540.00	36.6 AV	54.0	-17.4	2.04 H	254	23.1	13.5

ANTENNA POLARITY & TEST DISTANCE: VERTICAL AT 3 M

NO.	FREQ. (MHz)	EMISSION LEVEL (dBuV/m)	LIMIT (dBuV/m)	MARGIN (dB)	ANTENNA HEIGHT (m)	TABLE ANGLE (Degree)	RAW VALUE (dBuV)	CORRECTION FACTOR (dB/m)
1	5150.00	70.6 PK	74.0	-3.4	2.75 V	48	67.5	3.1
2	5150.00	52.4 AV	54.0	-1.6	2.75 V	48	49.3	3.1
3	*5180.00	116.5 PK			2.75 V	48	113.4	3.1
4	*5180.00	106.3 AV			2.75 V	48	103.2	3.1
5	#10360.00	40.3 PK	68.2	-27.9	1.57 V	273	27.2	13.1
6	15540.00	47.6 PK	74.0	-26.4	1.54 V	110	34.1	13.5
7	15540.00	34.3 AV	54.0	-19.7	1.54 V	110	20.8	13.5

REMARKS:

1. Emission Level(dBuV/m) = Raw Value(dBuV) + Correction Factor(dB/m)
2. Correction Factor(dB/m) = Antenna Factor(dB/m) + Cable Factor(dB) – Pre-Amplifier Factor(dB)
3. Margin value = Emission Level – Limit value
4. The other emission levels were very low against the limit.
5. " * ": Fundamental frequency.
6. " # ": The radiated frequency is out of the restricted band.

CHANNEL	TX Channel 40	DETECTOR FUNCTION	Peak (PK)
FREQUENCY RANGE	1GHz ~ 40GHz		Average (AV)

ANTENNA POLARITY & TEST DISTANCE: HORIZONTAL AT 3 M

NO.	FREQ. (MHz)	EMISSION LEVEL (dBuV/m)	LIMIT (dBuV/m)	MARGIN (dB)	ANTENNA HEIGHT (m)	TABLE ANGLE (Degree)	RAW VALUE (dBuV)	CORRECTION FACTOR (dB/m)
1	5150.00	67.2 PK	74.0	-6.8	1.86 H	169	64.1	3.1
2	5150.00	48.6 AV	54.0	-5.4	1.86 H	169	45.5	3.1
3	*5200.00	120.9 PK			1.86 H	169	117.8	3.1
4	*5200.00	111.3 AV			1.86 H	169	108.2	3.1
5	#10400.00	44.4 PK	68.2	-23.8	1.59 H	175	31.1	13.3
6	15600.00	50.3 PK	74.0	-23.7	2.00 H	239	36.8	13.5
7	15600.00	37.8 AV	54.0	-16.2	2.00 H	239	24.3	13.5

ANTENNA POLARITY & TEST DISTANCE: VERTICAL AT 3 M

NO.	FREQ. (MHz)	EMISSION LEVEL (dBuV/m)	LIMIT (dBuV/m)	MARGIN (dB)	ANTENNA HEIGHT (m)	TABLE ANGLE (Degree)	RAW VALUE (dBuV)	CORRECTION FACTOR (dB/m)
1	5150.00	65.7 PK	74.0	-8.3	2.72 V	63	62.6	3.1
2	5150.00	46.8 AV	54.0	-7.2	2.72 V	63	43.7	3.1
3	*5200.00	119.3 PK			2.72 V	63	116.2	3.1
4	*5200.00	109.6 AV			2.72 V	63	106.5	3.1
5	#10400.00	42.3 PK	68.2	-25.9	1.61 V	269	29.0	13.3
6	15600.00	48.9 PK	74.0	-25.1	1.51 V	115	35.4	13.5
7	15600.00	36.0 AV	54.0	-18.0	1.51 V	115	22.5	13.5

REMARKS:

- Emission Level(dBuV/m) = Raw Value(dBuV) + Correction Factor(dB/m)
- Correction Factor(dB/m) = Antenna Factor(dB/m) + Cable Factor(dB) – Pre-Amplifier Factor(dB)
- Margin value = Emission Level – Limit value
- The other emission levels were very low against the limit.
- " * ": Fundamental frequency.
- " # ": The radiated frequency is out of the restricted band.

CHANNEL	TX Channel 48	DETECTOR FUNCTION	Peak (PK)
FREQUENCY RANGE	1GHz ~ 40GHz		Average (AV)

ANTENNA POLARITY & TEST DISTANCE: HORIZONTAL AT 3 M

NO.	FREQ. (MHz)	EMISSION LEVEL (dBuV/m)	LIMIT (dBuV/m)	MARGIN (dB)	ANTENNA HEIGHT (m)	TABLE ANGLE (Degree)	RAW VALUE (dBuV)	CORRECTION FACTOR (dB/m)
1	5150.00	55.7 PK	74.0	-18.3	1.91 H	169	52.6	3.1
2	5150.00	45.5 AV	54.0	-8.5	1.91 H	169	42.4	3.1
3	*5240.00	121.2 PK			1.91 H	169	118.2	3.0
4	*5240.00	111.7 AV			1.91 H	169	108.7	3.0
5	5350.00	58.9 PK	74.0	-15.1	1.91 H	169	55.8	3.1
6	5350.00	46.9 AV	54.0	-7.1	1.91 H	169	43.8	3.1
7	#10480.00	44.1 PK	68.2	-24.1	1.57 H	186	30.9	13.2
8	15720.00	50.4 PK	74.0	-23.6	1.98 H	254	37.1	13.3
9	15720.00	37.6 AV	54.0	-16.4	1.98 H	254	24.3	13.3

ANTENNA POLARITY & TEST DISTANCE: VERTICAL AT 3 M

NO.	FREQ. (MHz)	EMISSION LEVEL (dBuV/m)	LIMIT (dBuV/m)	MARGIN (dB)	ANTENNA HEIGHT (m)	TABLE ANGLE (Degree)	RAW VALUE (dBuV)	CORRECTION FACTOR (dB/m)
1	5150.00	53.6 PK	74.0	-20.4	2.75 V	54	50.5	3.1
2	5150.00	43.6 AV	54.0	-10.4	2.75 V	54	40.5	3.1
3	*5240.00	119.3 PK			2.75 V	54	116.3	3.0
4	*5240.00	109.5 AV			2.75 V	54	106.5	3.0
5	5350.00	56.4 PK	74.0	-17.6	2.75 V	54	53.3	3.1
6	5350.00	44.4 AV	54.0	-9.6	2.75 V	54	41.3	3.1
7	#10480.00	42.8 PK	68.2	-25.4	1.65 V	272	29.6	13.2
8	15720.00	48.3 PK	74.0	-25.7	1.56 V	122	35.0	13.3
9	15720.00	35.6 AV	54.0	-18.4	1.56 V	122	22.3	13.3

REMARKS:

1. Emission Level(dBuV/m) = Raw Value(dBuV) + Correction Factor(dB/m)
2. Correction Factor(dB/m) = Antenna Factor(dB/m) + Cable Factor(dB) – Pre-Amplifier Factor(dB)
3. Margin value = Emission Level – Limit value
4. The other emission levels were very low against the limit.
5. " * ": Fundamental frequency.
6. " # ": The radiated frequency is out of the restricted band.

CHANNEL	TX Channel 149	DETECTOR FUNCTION	Peak (PK)
FREQUENCY RANGE	1GHz ~ 40GHz		Average (AV)

ANTENNA POLARITY & TEST DISTANCE: HORIZONTAL AT 3 M

NO.	FREQ. (MHz)	EMISSION LEVEL (dBuV/m)	LIMIT (dBuV/m)	MARGIN (dB)	ANTENNA HEIGHT (m)	TABLE ANGLE (Degree)	RAW VALUE (dBuV)	CORRECTION FACTOR (dB/m)
1	#5646.07	60.7 PK	68.2	-7.5	1.82 H	174	57.2	3.5
2	*5745.00	122.8 PK			1.83 H	175	119.0	3.8
3	*5745.00	113.0 AV			1.83 H	175	109.2	3.8
4	#5943.36	57.1 PK	68.2	-11.1	1.82 H	174	53.0	4.1
5	11490.00	44.6 PK	74.0	-29.4	1.53 H	153	30.8	13.8
6	11490.00	35.1 AV	54.0	-18.9	1.53 H	153	21.3	13.8
7	#17235.00	64.3 PK	68.2	-3.9	1.52 H	99	47.3	17.0

ANTENNA POLARITY & TEST DISTANCE: VERTICAL AT 3 M

NO.	FREQ. (MHz)	EMISSION LEVEL (dBuV/m)	LIMIT (dBuV/m)	MARGIN (dB)	ANTENNA HEIGHT (m)	TABLE ANGLE (Degree)	RAW VALUE (dBuV)	CORRECTION FACTOR (dB/m)
1	#5613.99	55.6 PK	68.2	-12.6	3.53 V	81	52.2	3.4
2	*5745.00	118.4 PK			3.53 V	81	114.6	3.8
3	*5745.00	109.0 AV			3.53 V	81	105.2	3.8
4	#5928.66	53.2 PK	68.2	-15.0	3.53 V	81	49.2	4.0
5	11490.00	46.3 PK	74.0	-27.7	1.53 V	280	32.5	13.8
6	11490.00	36.2 AV	54.0	-17.8	1.53 V	280	22.4	13.8
7	#17235.00	63.6 PK	68.2	-4.6	1.48 V	111	46.6	17.0

REMARKS:

1. Emission Level(dBuV/m) = Raw Value(dBuV) + Correction Factor(dB/m)
2. Correction Factor(dB/m) = Antenna Factor(dB/m) + Cable Factor(dB) – Pre-Amplifier Factor(dB)
3. Margin value = Emission Level – Limit value
4. The other emission levels were very low against the limit.
5. " * ": Fundamental frequency.
6. " # ": The radiated frequency is out of the restricted band.

CHANNEL	TX Channel 157	DETECTOR FUNCTION	Peak (PK)
FREQUENCY RANGE	1GHz ~ 40GHz		Average (AV)

ANTENNA POLARITY & TEST DISTANCE: HORIZONTAL AT 3 M

NO.	FREQ. (MHz)	EMISSION LEVEL (dBuV/m)	LIMIT (dBuV/m)	MARGIN (dB)	ANTENNA HEIGHT (m)	TABLE ANGLE (Degree)	RAW VALUE (dBuV)	CORRECTION FACTOR (dB/m)
1	#5643.53	58.4 PK	68.2	-9.8	1.77 H	169	54.9	3.5
2	*5785.00	122.4 PK			1.77 H	169	118.5	3.9
3	*5785.00	112.7 AV			1.77 H	169	108.8	3.9
4	#5958.31	56.6 PK	68.2	-11.6	1.77 H	169	52.5	4.1
5	11570.00	44.7 PK	74.0	-29.3	1.49 H	163	31.2	13.5
6	11570.00	35.2 AV	54.0	-18.8	1.49 H	163	21.7	13.5
7	#17355.00	63.7 PK	68.2	-4.5	1.55 H	106	46.4	17.3

ANTENNA POLARITY & TEST DISTANCE: VERTICAL AT 3 M

NO.	FREQ. (MHz)	EMISSION LEVEL (dBuV/m)	LIMIT (dBuV/m)	MARGIN (dB)	ANTENNA HEIGHT (m)	TABLE ANGLE (Degree)	RAW VALUE (dBuV)	CORRECTION FACTOR (dB/m)
1	#5638.16	53.8 PK	68.2	-14.4	3.45 V	92	50.4	3.4
2	*5785.00	118.7 PK			3.46 V	92	114.8	3.9
3	*5785.00	109.1 AV			3.46 V	92	105.2	3.9
4	#6010.58	53.2 PK	68.2	-15.0	3.45 V	92	49.1	4.1
5	11570.00	46.4 PK	74.0	-27.6	1.48 V	265	32.9	13.5
6	11570.00	36.2 AV	54.0	-17.8	1.48 V	265	22.7	13.5
7	#17355.00	63.2 PK	68.2	-5.0	1.45 V	123	45.9	17.3

REMARKS:

1. Emission Level(dBuV/m) = Raw Value(dBuV) + Correction Factor(dB/m)
2. Correction Factor(dB/m) = Antenna Factor(dB/m) + Cable Factor(dB) – Pre-Amplifier Factor(dB)
3. Margin value = Emission Level – Limit value
4. The other emission levels were very low against the limit.
5. " * ": Fundamental frequency.
6. " # ": The radiated frequency is out of the restricted band.

CHANNEL	TX Channel 165	DETECTOR FUNCTION	Peak (PK)
FREQUENCY RANGE	1GHz ~ 40GHz		Average (AV)

ANTENNA POLARITY & TEST DISTANCE: HORIZONTAL AT 3 M

NO.	FREQ. (MHz)	EMISSION LEVEL (dBuV/m)	LIMIT (dBuV/m)	MARGIN (dB)	ANTENNA HEIGHT (m)	TABLE ANGLE (Degree)	RAW VALUE (dBuV)	CORRECTION FACTOR (dB/m)
1	#5624.61	58.7 PK	68.2	-9.5	1.65 H	170	55.3	3.4
2	*5825.00	123.0 PK			1.66 H	171	118.9	4.1
3	*5825.00	113.0 AV			1.66 H	171	108.9	4.1
4	#5926.76	56.9 PK	68.2	-11.3	1.65 H	170	53.0	3.9
5	11650.00	44.3 PK	74.0	-29.7	1.53 H	152	31.0	13.3
6	11650.00	34.8 AV	54.0	-19.2	1.53 H	152	21.5	13.3
7	#17475.00	64.0 PK	68.2	-4.2	1.49 H	112	45.5	18.5

ANTENNA POLARITY & TEST DISTANCE: VERTICAL AT 3 M

NO.	FREQ. (MHz)	EMISSION LEVEL (dBuV/m)	LIMIT (dBuV/m)	MARGIN (dB)	ANTENNA HEIGHT (m)	TABLE ANGLE (Degree)	RAW VALUE (dBuV)	CORRECTION FACTOR (dB/m)
1	#5629.54	54.9 PK	68.2	-13.3	3.57 V	77	51.5	3.4
2	*5825.00	118.5 PK			3.58 V	78	114.4	4.1
3	*5825.00	109.0 AV			3.58 V	78	104.9	4.1
4	#5930.36	54.1 PK	68.2	-14.1	3.57 V	77	50.0	4.1
5	11650.00	46.2 PK	74.0	-27.8	1.55 V	281	32.9	13.3
6	11650.00	36.1 AV	54.0	-17.9	1.55 V	281	22.8	13.3
7	#17475.00	63.1 PK	68.2	-5.1	1.47 V	117	44.6	18.5

REMARKS:

- Emission Level(dBuV/m) = Raw Value(dBuV) + Correction Factor(dB/m)
- Correction Factor(dB/m) = Antenna Factor(dB/m) + Cable Factor(dB) – Pre-Amplifier Factor(dB)
- Margin value = Emission Level – Limit value
- The other emission levels were very low against the limit.
- " * ": Fundamental frequency.
- " # ": The radiated frequency is out of the restricted band.

802.11ac (VHT20)

CHANNEL	TX Channel 36	DETECTOR FUNCTION	Peak (PK)
FREQUENCY RANGE	1GHz ~ 40GHz		Average (AV)

ANTENNA POLARITY & TEST DISTANCE: HORIZONTAL AT 3 M								
NO.	FREQ. (MHz)	EMISSION LEVEL (dBuV/m)	LIMIT (dBuV/m)	MARGIN (dB)	ANTENNA HEIGHT (m)	TABLE ANGLE (Degree)	RAW VALUE (dBuV)	CORRECTION FACTOR (dB/m)
1	5150.00	73.9 PK	74.0	-0.1	1.60 H	101	70.8	3.1
2	5150.00	53.5 AV	54.0	-0.5	1.60 H	101	50.4	3.1
3	*5180.00	119.1 PK			1.60 H	101	116.0	3.1
4	*5180.00	106.7 AV			1.60 H	101	103.6	3.1
5	#10360.00	41.5 PK	68.2	-26.7	1.64 H	149	28.4	13.1
6	15540.00	47.7 PK	74.0	-26.3	2.04 H	253	34.2	13.5
7	15540.00	35.4 AV	54.0	-18.6	2.04 H	253	21.9	13.5

ANTENNA POLARITY & TEST DISTANCE: VERTICAL AT 3 M								
NO.	FREQ. (MHz)	EMISSION LEVEL (dBuV/m)	LIMIT (dBuV/m)	MARGIN (dB)	ANTENNA HEIGHT (m)	TABLE ANGLE (Degree)	RAW VALUE (dBuV)	CORRECTION FACTOR (dB/m)
1	5150.00	72.6 PK	74.0	-1.4	2.74 V	36	69.5	3.1
2	5150.00	52.1 AV	54.0	-1.9	2.74 V	36	49.0	3.1
3	*5180.00	117.4 PK			2.74 V	36	114.3	3.1
4	*5180.00	104.6 AV			2.74 V	36	101.5	3.1
5	#10360.00	39.9 PK	68.2	-28.3	1.59 V	282	26.8	13.1
6	15540.00	47.6 PK	74.0	-26.4	1.56 V	112	34.1	13.5
7	15540.00	34.1 AV	54.0	-19.9	1.56 V	112	20.6	13.5

REMARKS:

1. Emission Level(dBuV/m) = Raw Value(dBuV) + Correction Factor(dB/m)
2. Correction Factor(dB/m) = Antenna Factor(dB/m) + Cable Factor(dB) – Pre-Amplifier Factor(dB)
3. Margin value = Emission Level – Limit value
4. The other emission levels were very low against the limit.
5. " * ": Fundamental frequency.
6. " # ": The radiated frequency is out of the restricted band.

CHANNEL	TX Channel 40	DETECTOR FUNCTION	Peak (PK)
FREQUENCY RANGE	1GHz ~ 40GHz		Average (AV)

ANTENNA POLARITY & TEST DISTANCE: HORIZONTAL AT 3 M

NO.	FREQ. (MHz)	EMISSION LEVEL (dBuV/m)	LIMIT (dBuV/m)	MARGIN (dB)	ANTENNA HEIGHT (m)	TABLE ANGLE (Degree)	RAW VALUE (dBuV)	CORRECTION FACTOR (dB/m)
1	5150.00	72.1 PK	74.0	-1.9	1.69 H	112	69.0	3.1
2	5150.00	53.0 AV	54.0	-1.0	1.69 H	112	49.9	3.1
3	*5200.00	121.9 PK			1.69 H	112	118.8	3.1
4	*5200.00	110.3 AV			1.69 H	112	107.2	3.1
5	#10400.00	44.2 PK	68.2	-24.0	1.62 H	154	30.9	13.3
6	15600.00	50.1 PK	74.0	-23.9	2.09 H	265	36.6	13.5
7	15600.00	37.6 AV	54.0	-16.4	2.09 H	265	24.1	13.5

ANTENNA POLARITY & TEST DISTANCE: VERTICAL AT 3 M

NO.	FREQ. (MHz)	EMISSION LEVEL (dBuV/m)	LIMIT (dBuV/m)	MARGIN (dB)	ANTENNA HEIGHT (m)	TABLE ANGLE (Degree)	RAW VALUE (dBuV)	CORRECTION FACTOR (dB/m)
1	5150.00	70.6 PK	74.0	-3.4	2.72 V	27	67.5	3.1
2	5150.00	51.4 AV	54.0	-2.6	2.72 V	27	48.3	3.1
3	*5200.00	119.6 PK			2.72 V	27	116.5	3.1
4	*5200.00	108.3 AV			2.72 V	27	105.2	3.1
5	#10400.00	39.8 PK	68.2	-28.4	1.53 V	287	26.5	13.3
6	15600.00	47.3 PK	74.0	-26.7	1.55 V	121	33.8	13.5
7	15600.00	34.4 AV	54.0	-19.6	1.55 V	121	20.9	13.5

REMARKS:

1. Emission Level(dBuV/m) = Raw Value(dBuV) + Correction Factor(dB/m)
2. Correction Factor(dB/m) = Antenna Factor(dB/m) + Cable Factor(dB) – Pre-Amplifier Factor(dB)
3. Margin value = Emission Level – Limit value
4. The other emission levels were very low against the limit.
5. " * ": Fundamental frequency.
6. " # ": The radiated frequency is out of the restricted band.

CHANNEL	TX Channel 48	DETECTOR FUNCTION	Peak (PK)
FREQUENCY RANGE	1GHz ~ 40GHz		Average (AV)

ANTENNA POLARITY & TEST DISTANCE: HORIZONTAL AT 3 M

NO.	FREQ. (MHz)	EMISSION LEVEL (dBuV/m)	LIMIT (dBuV/m)	MARGIN (dB)	ANTENNA HEIGHT (m)	TABLE ANGLE (Degree)	RAW VALUE (dBuV)	CORRECTION FACTOR (dB/m)
1	5150.00	54.6 PK	74.0	-19.4	1.71 H	98	51.5	3.1
2	5150.00	44.2 AV	54.0	-9.8	1.71 H	98	41.1	3.1
3	*5240.00	118.7 PK			1.71 H	98	115.7	3.0
4	*5240.00	107.4 AV			1.71 H	98	104.4	3.0
5	5350.00	55.4 PK	74.0	-18.6	1.71 H	98	52.3	3.1
6	5350.00	44.3 AV	54.0	-9.7	1.71 H	98	41.2	3.1
7	#10480.00	40.9 PK	68.2	-27.3	1.62 H	154	27.7	13.2
8	15720.00	48.3 PK	74.0	-25.7	2.01 H	243	35.0	13.3
9	15720.00	35.7 AV	54.0	-18.3	2.01 H	243	22.4	13.3

ANTENNA POLARITY & TEST DISTANCE: VERTICAL AT 3 M

NO.	FREQ. (MHz)	EMISSION LEVEL (dBuV/m)	LIMIT (dBuV/m)	MARGIN (dB)	ANTENNA HEIGHT (m)	TABLE ANGLE (Degree)	RAW VALUE (dBuV)	CORRECTION FACTOR (dB/m)
1	5150.00	53.3 PK	74.0	-20.7	2.69 V	32	50.2	3.1
2	5150.00	42.0 AV	54.0	-12.0	2.69 V	32	38.9	3.1
3	*5240.00	116.5 PK			2.69 V	32	113.5	3.0
4	*5240.00	105.3 AV			2.69 V	32	102.3	3.0
5	5350.00	53.6 PK	74.0	-20.4	2.69 V	32	50.5	3.1
6	5350.00	42.1 AV	54.0	-11.9	2.69 V	32	39.0	3.1
7	#10480.00	39.7 PK	68.2	-28.5	1.60 V	298	26.5	13.2
8	15720.00	47.5 PK	74.0	-26.5	1.62 V	125	34.2	13.3
9	15720.00	34.6 AV	54.0	-19.4	1.62 V	125	21.3	13.3

REMARKS:

1. Emission Level(dBuV/m) = Raw Value(dBuV) + Correction Factor(dB/m)
2. Correction Factor(dB/m) = Antenna Factor(dB/m) + Cable Factor(dB) – Pre-Amplifier Factor(dB)
3. Margin value = Emission Level – Limit value
4. The other emission levels were very low against the limit.
5. " * ": Fundamental frequency.
6. " # ": The radiated frequency is out of the restricted band.

CHANNEL	TX Channel 149	DETECTOR FUNCTION	Peak (PK)
FREQUENCY RANGE	1GHz ~ 40GHz		Average (AV)

ANTENNA POLARITY & TEST DISTANCE: HORIZONTAL AT 3 M

NO.	FREQ. (MHz)	EMISSION LEVEL (dBuV/m)	LIMIT (dBuV/m)	MARGIN (dB)	ANTENNA HEIGHT (m)	TABLE ANGLE (Degree)	RAW VALUE (dBuV)	CORRECTION FACTOR (dB/m)
1	#5647.34	58.9 PK	68.2	-9.3	1.65 H	171	55.4	3.5
2	*5745.00	121.3 PK			1.66 H	172	117.5	3.8
3	*5745.00	111.6 AV			1.66 H	172	107.8	3.8
4	#6013.77	56.3 PK	68.2	-11.9	1.65 H	171	52.2	4.1
5	11490.00	44.0 PK	74.0	-30.0	1.56 H	143	30.2	13.8
6	11490.00	34.7 AV	54.0	-19.3	1.56 H	143	20.9	13.8
7	#17235.00	63.8 PK	68.2	-4.4	1.48 H	100	46.8	17.0

ANTENNA POLARITY & TEST DISTANCE: VERTICAL AT 3 M

NO.	FREQ. (MHz)	EMISSION LEVEL (dBuV/m)	LIMIT (dBuV/m)	MARGIN (dB)	ANTENNA HEIGHT (m)	TABLE ANGLE (Degree)	RAW VALUE (dBuV)	CORRECTION FACTOR (dB/m)
1	#5649.06	54.6 PK	68.2	-13.6	3.66 V	75	51.1	3.5
2	*5745.00	119.3 PK			3.66 V	76	115.5	3.8
3	*5745.00	108.0 AV			3.66 V	76	104.2	3.8
4	#5990.75	54.2 PK	68.2	-14.0	3.66 V	75	50.1	4.1
5	11490.00	45.8 PK	74.0	-28.2	1.52 V	271	32.0	13.8
6	11490.00	35.8 AV	54.0	-18.2	1.52 V	271	22.0	13.8
7	#17235.00	63.3 PK	68.2	-4.9	1.56 V	118	46.3	17.0

REMARKS:

1. Emission Level(dBuV/m) = Raw Value(dBuV) + Correction Factor(dB/m)
2. Correction Factor(dB/m) = Antenna Factor(dB/m) + Cable Factor(dB) – Pre-Amplifier Factor(dB)
3. Margin value = Emission Level – Limit value
4. The other emission levels were very low against the limit.
5. " * ": Fundamental frequency.
6. " # ": The radiated frequency is out of the restricted band.

CHANNEL	TX Channel 157	DETECTOR FUNCTION	Peak (PK)
FREQUENCY RANGE	1GHz ~ 40GHz		Average (AV)

ANTENNA POLARITY & TEST DISTANCE: HORIZONTAL AT 3 M

NO.	FREQ. (MHz)	EMISSION LEVEL (dBuV/m)	LIMIT (dBuV/m)	MARGIN (dB)	ANTENNA HEIGHT (m)	TABLE ANGLE (Degree)	RAW VALUE (dBuV)	CORRECTION FACTOR (dB/m)
1	#5597.73	58.6 PK	68.2	-9.6	1.34 H	178	55.2	3.4
2	*5785.00	121.6 PK			1.34 H	178	117.7	3.9
3	*5785.00	111.8 AV			1.34 H	178	107.9	3.9
4	#5945.82	57.0 PK	68.2	-11.2	1.34 H	178	52.9	4.1
5	11570.00	44.7 PK	74.0	-29.3	1.51 H	154	31.2	13.5
6	11570.00	35.3 AV	54.0	-18.7	1.51 H	154	21.8	13.5
7	#17355.00	63.8 PK	68.2	-4.4	1.49 H	108	46.5	17.3

ANTENNA POLARITY & TEST DISTANCE: VERTICAL AT 3 M

NO.	FREQ. (MHz)	EMISSION LEVEL (dBuV/m)	LIMIT (dBuV/m)	MARGIN (dB)	ANTENNA HEIGHT (m)	TABLE ANGLE (Degree)	RAW VALUE (dBuV)	CORRECTION FACTOR (dB/m)
1	#5638.42	55.5 PK	68.2	-12.7	3.65 V	69	52.1	3.4
2	*5785.00	119.5 PK			3.65 V	70	115.6	3.9
3	*5785.00	108.3 AV			3.65 V	70	104.4	3.9
4	#6013.73	53.7 PK	68.2	-14.5	3.65 V	69	49.6	4.1
5	11570.00	46.8 PK	74.0	-27.2	1.50 V	273	33.3	13.5
6	11570.00	36.6 AV	54.0	-17.4	1.50 V	273	23.1	13.5
7	#17355.00	64.2 PK	68.2	-4.0	1.58 V	116	46.9	17.3

REMARKS:

1. Emission Level(dBuV/m) = Raw Value(dBuV) + Correction Factor(dB/m)
2. Correction Factor(dB/m) = Antenna Factor(dB/m) + Cable Factor(dB) – Pre-Amplifier Factor(dB)
3. Margin value = Emission Level – Limit value
4. The other emission levels were very low against the limit.
5. " * ": Fundamental frequency.
6. " # ": The radiated frequency is out of the restricted band.

CHANNEL	TX Channel 165	DETECTOR FUNCTION	Peak (PK)
FREQUENCY RANGE	1GHz ~ 40GHz		Average (AV)

ANTENNA POLARITY & TEST DISTANCE: HORIZONTAL AT 3 M

NO.	FREQ. (MHz)	EMISSION LEVEL (dBuV/m)	LIMIT (dBuV/m)	MARGIN (dB)	ANTENNA HEIGHT (m)	TABLE ANGLE (Degree)	RAW VALUE (dBuV)	CORRECTION FACTOR (dB/m)
1	#5604.93	58.2 PK	68.2	-10.0	1.64 H	179	54.8	3.4
2	*5825.00	121.9 PK			1.65 H	180	117.8	4.1
3	*5825.00	111.8 AV			1.65 H	180	107.7	4.1
4	#5961.55	57.1 PK	68.2	-11.1	1.64 H	179	53.0	4.1
5	11650.00	44.9 PK	74.0	-29.1	1.57 H	151	31.6	13.3
6	11650.00	35.3 AV	54.0	-18.7	1.57 H	151	22.0	13.3
7	#17475.00	64.1 PK	68.2	-4.1	1.46 H	123	45.6	18.5

ANTENNA POLARITY & TEST DISTANCE: VERTICAL AT 3 M

NO.	FREQ. (MHz)	EMISSION LEVEL (dBuV/m)	LIMIT (dBuV/m)	MARGIN (dB)	ANTENNA HEIGHT (m)	TABLE ANGLE (Degree)	RAW VALUE (dBuV)	CORRECTION FACTOR (dB/m)
1	#5586.78	55.5 PK	68.2	-12.7	3.80 V	59	52.5	3.0
2	*5825.00	119.2 PK			3.81 V	60	115.1	4.1
3	*5825.00	107.8 AV			3.81 V	60	103.7	4.1
4	#5928.01	54.3 PK	68.2	-13.9	3.80 V	59	50.4	3.9
5	11650.00	46.2 PK	74.0	-27.8	1.50 V	278	32.9	13.3
6	11650.00	36.3 AV	54.0	-17.7	1.50 V	278	23.0	13.3
7	#17475.00	63.3 PK	68.2	-4.9	1.59 V	105	44.8	18.5

REMARKS:

1. Emission Level(dBuV/m) = Raw Value(dBuV) + Correction Factor(dB/m)
2. Correction Factor(dB/m) = Antenna Factor(dB/m) + Cable Factor(dB) – Pre-Amplifier Factor(dB)
3. Margin value = Emission Level – Limit value
4. The other emission levels were very low against the limit.
5. " * ": Fundamental frequency.
6. " # ": The radiated frequency is out of the restricted band.

802.11ac (VHT40)

CHANNEL	TX Channel 38	DETECTOR FUNCTION	Peak (PK)
FREQUENCY RANGE	1GHz ~ 40GHz		Average (AV)

ANTENNA POLARITY & TEST DISTANCE: HORIZONTAL AT 3 M								
NO.	FREQ. (MHz)	EMISSION LEVEL (dBuV/m)	LIMIT (dBuV/m)	MARGIN (dB)	ANTENNA HEIGHT (m)	TABLE ANGLE (Degree)	RAW VALUE (dBuV)	CORRECTION FACTOR (dB/m)
1	5150.00	69.4 PK	74.0	-4.6	1.68 H	104	66.3	3.1
2	5150.00	53.6 AV	54.0	-0.4	1.68 H	104	50.5	3.1
3	*5190.00	113.2 PK			1.68 H	104	110.0	3.2
4	*5190.00	101.3 AV			1.68 H	104	98.1	3.2
5	#10380.00	38.6 PK	68.2	-29.6	1.62 H	159	25.4	13.2
6	15570.00	46.5 PK	74.0	-27.5	1.96 H	229	33.0	13.5
7	15570.00	33.2 AV	54.0	-20.8	1.96 H	229	19.7	13.5

ANTENNA POLARITY & TEST DISTANCE: VERTICAL AT 3 M								
NO.	FREQ. (MHz)	EMISSION LEVEL (dBuV/m)	LIMIT (dBuV/m)	MARGIN (dB)	ANTENNA HEIGHT (m)	TABLE ANGLE (Degree)	RAW VALUE (dBuV)	CORRECTION FACTOR (dB/m)
1	5150.00	67.9 PK	74.0	-6.1	2.70 V	46	64.8	3.1
2	5150.00	52.0 AV	54.0	-2.0	2.70 V	46	48.9	3.1
3	*5190.00	111.6 PK			2.70 V	46	108.4	3.2
4	*5190.00	99.4 AV			2.70 V	46	96.2	3.2
5	#10380.00	37.4 PK	68.2	-30.8	1.57 V	288	24.2	13.2
6	15570.00	45.4 PK	74.0	-28.6	1.59 V	137	31.9	13.5
7	15570.00	33.0 AV	54.0	-21.0	1.59 V	137	19.5	13.5

REMARKS:

1. Emission Level(dBuV/m) = Raw Value(dBuV) + Correction Factor(dB/m)
2. Correction Factor(dB/m) = Antenna Factor(dB/m) + Cable Factor(dB) – Pre-Amplifier Factor(dB)
3. Margin value = Emission Level – Limit value
4. The other emission levels were very low against the limit.
5. " * ": Fundamental frequency.
6. " # ": The radiated frequency is out of the restricted band.

CHANNEL	TX Channel 46	DETECTOR FUNCTION	Peak (PK)
FREQUENCY RANGE	1GHz ~ 40GHz		Average (AV)

ANTENNA POLARITY & TEST DISTANCE: HORIZONTAL AT 3 M

NO.	FREQ. (MHz)	EMISSION LEVEL (dBuV/m)	LIMIT (dBuV/m)	MARGIN (dB)	ANTENNA HEIGHT (m)	TABLE ANGLE (Degree)	RAW VALUE (dBuV)	CORRECTION FACTOR (dB/m)
1	5150.00	67.9 PK	74.0	-6.1	1.60 H	99	64.8	3.1
2	5150.00	53.9 AV	54.0	-0.1	1.60 H	99	50.8	3.1
3	*5230.00	118.3 PK			1.60 H	99	115.3	3.0
4	*5230.00	107.0 AV			1.60 H	99	104.0	3.0
5	5350.00	58.8 PK	74.0	-15.2	1.60 H	99	55.7	3.1
6	5350.00	46.3 AV	54.0	-7.7	1.60 H	99	43.2	3.1
7	#10460.00	40.4 PK	68.2	-27.8	1.60 H	160	27.1	13.3
8	15690.00	48.9 PK	74.0	-25.1	1.97 H	234	35.4	13.5
9	15690.00	35.6 AV	54.0	-18.4	1.97 H	234	22.1	13.5

ANTENNA POLARITY & TEST DISTANCE: VERTICAL AT 3 M

NO.	FREQ. (MHz)	EMISSION LEVEL (dBuV/m)	LIMIT (dBuV/m)	MARGIN (dB)	ANTENNA HEIGHT (m)	TABLE ANGLE (Degree)	RAW VALUE (dBuV)	CORRECTION FACTOR (dB/m)
1	5150.00	66.0 PK	74.0	-8.0	2.74 V	50	62.9	3.1
2	5150.00	51.9 AV	54.0	-2.1	2.74 V	50	48.8	3.1
3	*5230.00	116.8 PK			2.74 V	50	113.8	3.0
4	*5230.00	105.4 AV			2.74 V	50	102.4	3.0
5	5350.00	57.1 PK	74.0	-16.9	2.74 V	50	54.0	3.1
6	5350.00	44.4 AV	54.0	-9.6	2.74 V	50	41.3	3.1
7	#10460.00	39.3 PK	68.2	-28.9	1.66 V	292	26.0	13.3
8	15690.00	47.7 PK	74.0	-26.3	1.58 V	114	34.2	13.5
9	15690.00	35.0 AV	54.0	-19.0	1.58 V	114	21.5	13.5

REMARKS:

1. Emission Level(dBuV/m) = Raw Value(dBuV) + Correction Factor(dB/m)
2. Correction Factor(dB/m) = Antenna Factor(dB/m) + Cable Factor(dB) – Pre-Amplifier Factor(dB)
3. Margin value = Emission Level – Limit value
4. The other emission levels were very low against the limit.
5. " * ": Fundamental frequency.
6. " # ": The radiated frequency is out of the restricted band.

CHANNEL	TX Channel 151	DETECTOR FUNCTION	Peak (PK)
FREQUENCY RANGE	1GHz ~ 40GHz		Average (AV)

ANTENNA POLARITY & TEST DISTANCE: HORIZONTAL AT 3 M

NO.	FREQ. (MHz)	EMISSION LEVEL (dBuV/m)	LIMIT (dBuV/m)	MARGIN (dB)	ANTENNA HEIGHT (m)	TABLE ANGLE (Degree)	RAW VALUE (dBuV)	CORRECTION FACTOR (dB/m)
1	#5646.07	65.9 PK	68.2	-2.3	1.24 H	175	62.4	3.5
2	*5755.00	118.5 PK			1.25 H	175	114.7	3.8
3	*5755.00	108.2 AV			1.25 H	175	104.4	3.8
4	#5932.89	58.5 PK	68.2	-9.7	1.24 H	175	54.4	4.1
5	11510.00	43.6 PK	74.0	-30.4	1.54 H	139	29.9	13.7
6	11510.00	33.6 AV	54.0	-20.4	1.54 H	139	19.9	13.7
7	#17265.00	62.3 PK	68.2	-5.9	1.52 H	116	45.3	17.0

ANTENNA POLARITY & TEST DISTANCE: VERTICAL AT 3 M

NO.	FREQ. (MHz)	EMISSION LEVEL (dBuV/m)	LIMIT (dBuV/m)	MARGIN (dB)	ANTENNA HEIGHT (m)	TABLE ANGLE (Degree)	RAW VALUE (dBuV)	CORRECTION FACTOR (dB/m)
1	#5640.52	60.4 PK	68.2	-7.8	3.67 V	75	57.0	3.4
2	*5755.00	116.6 PK			3.67 V	76	112.8	3.8
3	*5755.00	105.3 AV			3.67 V	76	101.5	3.8
4	#5945.84	55.4 PK	68.2	-12.8	3.67 V	75	51.3	4.1
5	11510.00	45.5 PK	74.0	-28.5	1.49 V	266	31.8	13.7
6	11510.00	34.2 AV	54.0	-19.8	1.49 V	266	20.5	13.7
7	#17265.00	62.6 PK	68.2	-5.6	1.55 V	115	45.6	17.0

REMARKS:

1. Emission Level(dBuV/m) = Raw Value(dBuV) + Correction Factor(dB/m)
2. Correction Factor(dB/m) = Antenna Factor(dB/m) + Cable Factor(dB) – Pre-Amplifier Factor(dB)
3. Margin value = Emission Level – Limit value
4. The other emission levels were very low against the limit.
5. " * ": Fundamental frequency.
6. " # ": The radiated frequency is out of the restricted band.

CHANNEL	TX Channel 159	DETECTOR FUNCTION	Peak (PK)
FREQUENCY RANGE	1GHz ~ 40GHz		Average (AV)

ANTENNA POLARITY & TEST DISTANCE: HORIZONTAL AT 3 M

NO.	FREQ. (MHz)	EMISSION LEVEL (dBuV/m)	LIMIT (dBuV/m)	MARGIN (dB)	ANTENNA HEIGHT (m)	TABLE ANGLE (Degree)	RAW VALUE (dBuV)	CORRECTION FACTOR (dB/m)
1	#5642.42	60.5 PK	68.2	-7.7	1.32 H	177	57.0	3.5
2	*5795.00	119.3 PK			1.33 H	177	115.4	3.9
3	*5795.00	109.2 AV			1.33 H	177	105.3	3.9
4	#5980.46	58.9 PK	68.2	-9.3	1.32 H	177	54.8	4.1
5	11590.00	43.8 PK	74.0	-30.2	1.52 H	144	30.2	13.6
6	11590.00	33.7 AV	54.0	-20.3	1.52 H	144	20.1	13.6
7	#17385.00	62.0 PK	68.2	-6.2	1.49 H	112	44.7	17.3

ANTENNA POLARITY & TEST DISTANCE: VERTICAL AT 3 M

NO.	FREQ. (MHz)	EMISSION LEVEL (dBuV/m)	LIMIT (dBuV/m)	MARGIN (dB)	ANTENNA HEIGHT (m)	TABLE ANGLE (Degree)	RAW VALUE (dBuV)	CORRECTION FACTOR (dB/m)
1	#5638.98	57.0 PK	68.2	-11.2	3.61 V	78	53.6	3.4
2	*5795.00	117.5 PK			3.62 V	79	113.6	3.9
3	*5795.00	106.0 AV			3.62 V	79	102.1	3.9
4	#5929.64	56.8 PK	68.2	-11.4	3.61 V	78	52.8	4.0
5	11590.00	45.2 PK	74.0	-28.8	1.46 V	291	31.6	13.6
6	11590.00	34.0 AV	54.0	-20.0	1.46 V	291	20.4	13.6
7	#17385.00	62.7 PK	68.2	-5.5	1.65 V	109	45.4	17.3

REMARKS:

1. Emission Level(dBuV/m) = Raw Value(dBuV) + Correction Factor(dB/m)
2. Correction Factor(dB/m) = Antenna Factor(dB/m) + Cable Factor(dB) – Pre-Amplifier Factor(dB)
3. Margin value = Emission Level – Limit value
4. The other emission levels were very low against the limit.
5. " * ": Fundamental frequency.
6. " # ": The radiated frequency is out of the restricted band.

802.11ac (VHT80)

CHANNEL	TX Channel 42	DETECTOR FUNCTION	Peak (PK)
FREQUENCY RANGE	1GHz ~ 40GHz		Average (AV)

ANTENNA POLARITY & TEST DISTANCE: HORIZONTAL AT 3 M

NO.	FREQ. (MHz)	EMISSION LEVEL (dBuV/m)	LIMIT (dBuV/m)	MARGIN (dB)	ANTENNA HEIGHT (m)	TABLE ANGLE (Degree)	RAW VALUE (dBuV)	CORRECTION FACTOR (dB/m)
1	5150.00	66.4 PK	74.0	-7.6	1.43 H	145	63.3	3.1
2	5150.00	53.6 AV	54.0	-0.4	1.43 H	145	50.5	3.1
3	*5210.00	108.4 PK			1.43 H	145	105.3	3.1
4	*5210.00	97.1 AV			1.43 H	145	94.0	3.1
5	5350.00	54.7 PK	74.0	-19.3	1.43 H	145	51.6	3.1
6	5350.00	43.1 AV	54.0	-10.9	1.43 H	145	40.0	3.1
7	#10420.00	38.6 PK	68.2	-29.6	1.57 H	170	25.3	13.3
8	15630.00	46.4 PK	74.0	-27.6	2.03 H	249	32.8	13.6
9	15630.00	33.2 AV	54.0	-20.8	2.03 H	249	19.6	13.6

ANTENNA POLARITY & TEST DISTANCE: VERTICAL AT 3 M

NO.	FREQ. (MHz)	EMISSION LEVEL (dBuV/m)	LIMIT (dBuV/m)	MARGIN (dB)	ANTENNA HEIGHT (m)	TABLE ANGLE (Degree)	RAW VALUE (dBuV)	CORRECTION FACTOR (dB/m)
1	5150.00	63.4 PK	74.0	-10.6	2.79 V	46	60.3	3.1
2	5150.00	52.6 AV	54.0	-1.4	2.79 V	46	49.5	3.1
3	*5210.00	106.9 PK			2.79 V	46	103.8	3.1
4	*5210.00	95.0 AV			2.79 V	46	91.9	3.1
5	5350.00	53.5 PK	74.0	-20.5	2.79 V	46	50.4	3.1
6	5350.00	41.8 AV	54.0	-12.2	2.79 V	46	38.7	3.1
7	#10420.00	37.7 PK	68.2	-30.5	1.64 V	303	24.4	13.3
8	15630.00	45.5 PK	74.0	-28.5	1.53 V	117	31.9	13.6
9	15630.00	32.6 AV	54.0	-21.4	1.53 V	117	19.0	13.6

REMARKS:

1. Emission Level(dBuV/m) = Raw Value(dBuV) + Correction Factor(dB/m)
2. Correction Factor(dB/m) = Antenna Factor(dB/m) + Cable Factor(dB) – Pre-Amplifier Factor(dB)
3. Margin value = Emission Level – Limit value
4. The other emission levels were very low against the limit.
5. " * ": Fundamental frequency.
6. " # ": The radiated frequency is out of the restricted band.

CHANNEL	TX Channel 155	DETECTOR FUNCTION	Peak (PK)
FREQUENCY RANGE	1GHz ~ 40GHz		Average (AV)

ANTENNA POLARITY & TEST DISTANCE: HORIZONTAL AT 3 M

NO.	FREQ. (MHz)	EMISSION LEVEL (dBuV/m)	LIMIT (dBuV/m)	MARGIN (dB)	ANTENNA HEIGHT (m)	TABLE ANGLE (Degree)	RAW VALUE (dBuV)	CORRECTION FACTOR (dB/m)
1	#5631.38	67.8 PK	68.2	-0.4	1.25 H	176	64.4	3.4
2	*5775.00	116.4 PK			1.25 H	176	112.5	3.9
3	*5775.00	104.8 AV			1.25 H	176	100.9	3.9
4	#5928.06	65.4 PK	68.2	-2.8	1.25 H	176	61.5	3.9
5	11550.00	42.1 PK	74.0	-31.9	1.54 H	150	28.5	13.6
6	11550.00	32.1 AV	54.0	-21.9	1.54 H	150	18.5	13.6
7	#17325.00	61.0 PK	68.2	-7.2	1.49 H	110	43.9	17.1

ANTENNA POLARITY & TEST DISTANCE: VERTICAL AT 3 M

NO.	FREQ. (MHz)	EMISSION LEVEL (dBuV/m)	LIMIT (dBuV/m)	MARGIN (dB)	ANTENNA HEIGHT (m)	TABLE ANGLE (Degree)	RAW VALUE (dBuV)	CORRECTION FACTOR (dB/m)
1	#5647.55	64.2 PK	68.2	-4.0	3.63 V	78	60.7	3.5
2	*5775.00	113.1 PK			3.64 V	78	109.2	3.9
3	*5775.00	100.8 AV			3.64 V	78	96.9	3.9
4	#5931.44	56.5 PK	68.2	-11.7	3.63 V	78	52.4	4.1
5	11550.00	44.0 PK	74.0	-30.0	1.51 V	260	30.4	13.6
6	11550.00	33.3 AV	54.0	-20.7	1.51 V	260	19.7	13.6
7	#17325.00	61.6 PK	68.2	-6.6	1.61 V	112	44.5	17.1

REMARKS:

1. Emission Level(dBuV/m) = Raw Value(dBuV) + Correction Factor(dB/m)
2. Correction Factor(dB/m) = Antenna Factor(dB/m) + Cable Factor(dB) – Pre-Amplifier Factor(dB)
3. Margin value = Emission Level – Limit value
4. The other emission levels were very low against the limit.
5. " * ": Fundamental frequency.
6. " # ": The radiated frequency is out of the restricted band.

Below 1GHz Data:
802.11ax (HE40)

CHANNEL	TX Channel 151	DETECTOR FUNCTION	Quasi-Peak (QP)
FREQUENCY RANGE	9kHz ~ 1GHz		

ANTENNA POLARITY & TEST DISTANCE: HORIZONTAL AT 3 M

NO.	FREQ. (MHz)	EMISSION LEVEL (dBuV/m)	LIMIT (dBuV/m)	MARGIN (dB)	ANTENNA HEIGHT (m)	TABLE ANGLE (Degree)	RAW VALUE (dBuV)	CORRECTION FACTOR (dB/m)
1	30.29	20.8 QP	40.0	-19.2	2.00 H	89	30.5	-9.7
2	92.33	28.6 QP	43.5	-14.9	2.00 H	251	41.5	-12.9
3	182.15	28.1 QP	43.5	-15.4	1.50 H	273	37.5	-9.4
4	249.96	33.7 QP	46.0	-12.3	1.00 H	251	42.3	-8.6
5	449.98	36.9 QP	46.0	-9.1	1.50 H	266	39.4	-2.5
6	850.03	38.2 QP	46.0	-7.8	1.50 H	240	33.0	5.2

REMARKS:

1. Emission Level(dBuV/m) = Raw Value(dBuV) + Correction Factor(dB/m)
2. Correction Factor(dB/m) = Antenna Factor(dB/m) + Cable Factor(dB) – Pre-Amplifier Factor(dB)
3. Margin value = Emission Level – Limit value
4. The other emission levels were very low against the limit of frequency range 30MHz~1000MHz.
5. The emission levels were very low against the limit of frequency range 9kHz~30MHz: the amplitude of spurious emissions attenuated more than 20 dB below the permissible value to be report.

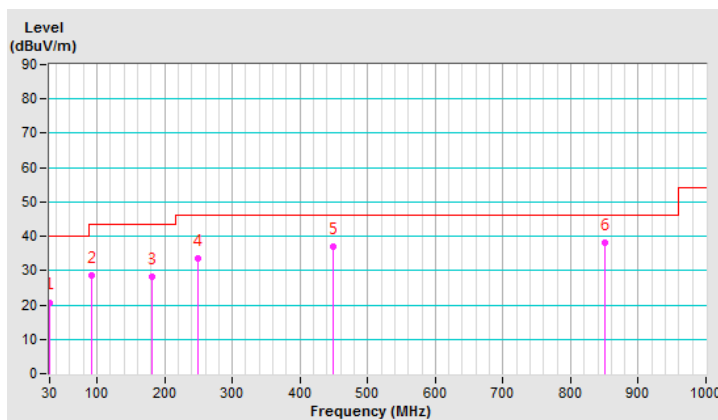

CHANNEL	TX Channel 151	DETECTOR FUNCTION	Quasi-Peak (QP)
FREQUENCY RANGE	9kHz ~ 1GHz		

ANTENNA POLARITY & TEST DISTANCE: VERTICAL AT 3 M

NO.	FREQ. (MHz)	EMISSION LEVEL (dBuV/m)	LIMIT (dBuV/m)	MARGIN (dB)	ANTENNA HEIGHT (m)	TABLE ANGLE (Degree)	RAW VALUE (dBuV)	CORRECTION FACTOR (dB/m)
1	43.48	28.8 QP	40.0	-11.2	1.50 V	96	37.2	-8.4
2	59.49	29.7 QP	40.0	-10.3	2.00 V	251	38.4	-8.7
3	94.33	30.7 QP	43.5	-12.8	1.50 V	143	43.5	-12.8
4	141.71	37.7 QP	43.5	-5.8	2.00 V	26	45.7	-8.0
5	746.77	39.2 QP	46.0	-6.8	3.00 V	239	35.6	3.6
6	849.98	37.3 QP	46.0	-8.7	1.00 V	289	32.1	5.2

REMARKS:

1. Emission Level(dBuV/m) = Raw Value(dBuV) + Correction Factor(dB/m)
2. Correction Factor(dB/m) = Antenna Factor(dB/m) + Cable Factor(dB) – Pre-Amplifier Factor(dB)
3. Margin value = Emission Level – Limit value
4. The other emission levels were very low against the limit of frequency range 30MHz~1000MHz.
5. The emission levels were very low against the limit of frequency range 9kHz~30MHz: the amplitude of spurious emissions attenuated more than 20 dB below the permissible value to be report.

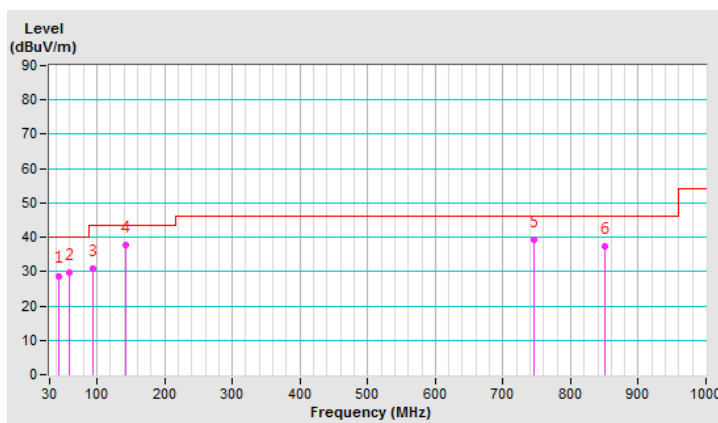

4.2 Conducted Emission Measurement

4.2.1 Limits of Conducted Emission Measurement

Frequency (MHz)	Conducted Limit (dBuV)	
	Quasi-peak	Average
0.15 - 0.5	66 - 56	56 - 46
0.50 - 5.0	56	46
5.0 - 30.0	60	50

Note: 1. The lower limit shall apply at the transition frequencies.

2. The limit decreases in line with the logarithm of the frequency in the range of 0.15 to 0.50MHz.

4.2.2 Test Instruments

DESCRIPTION & MANUFACTURER	MODEL NO.	SERIAL NO.	CALIBRATED DATE	CALIBRATED UNTIL
Test Receiver R&S	ESCS 30	847124/029	Oct. 23, 2019	Oct. 22, 2020
Line-Impedance Stabilization Network (for EUT) R&S	ESH3-Z5	848773/004	Oct. 23, 2019	Oct. 22, 2020
Line-Impedance Stabilization Network (for Peripheral) R&S	ESH3-Z5	835239/001	Mar. 17, 2019	Mar. 16, 2020
50 ohms Terminator	50	3	Oct. 23, 2019	Oct. 22, 2020
RF Cable	5D-FB	COCCAB-001	Sep. 27, 2019	Sep. 26, 2020
Fixed attenuator EMCI	STI02-2200-10	003	Mar. 14, 2019	Mar. 13, 2020
Software BVADT	BVADT_Cond_V7.3.7.4	NA	NA	NA

Note:

1. The calibration interval of the above test instruments are 12 months and the calibrations are traceable to NML/ROC and NIST/USA.
2. The test was performed in Conduction 1.
3. Tested Date: Nov. 13, 2019

4.2.3 Test Procedure

- The EUT was placed 0.4 meters from the conducting wall of the shielded room with EUT being connected to the power mains through a line impedance stabilization network (LISN). Other support units were connected to the power mains through another LISN. The two LISNs provide 50 ohm/ 50uH of coupling impedance for the measuring instrument.
- Both lines of the power mains connected to the EUT were checked for maximum conducted interference.
- The frequency range from 150kHz to 30MHz was searched. Emission levels under (Limit - 20dB) was not recorded.

NOTE: All modes of operation were investigated and the worst-case emissions are reported.

4.2.4 Deviation from Test Standard

No deviation.

4.2.5 Test Setup

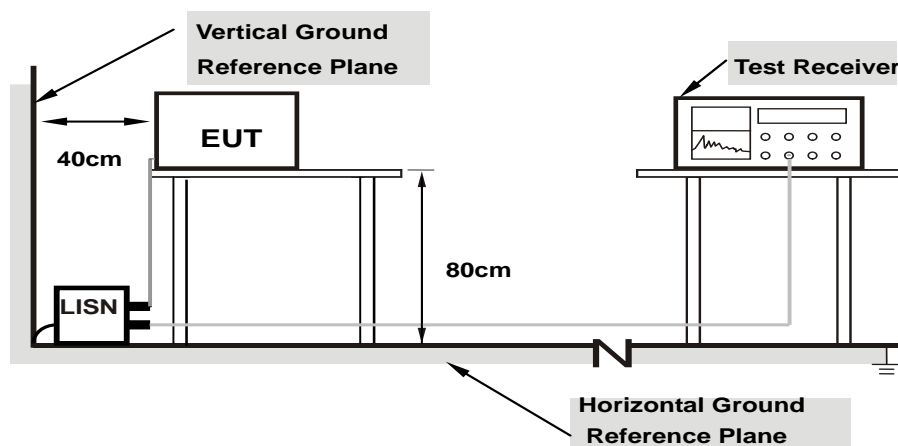

Note: 1.Support units were connected to second LISN.

For the actual test configuration, please refer to the attached file (Test Setup Photo).

4.2.6 EUT Operating Condition

Same as 4.1.6.

4.2.7 Test Results

Phase	Line (L)	Detector Function	Quasi-Peak (QP) / Average (AV)
-------	----------	-------------------	--------------------------------

No	Freq. [MHz]	Corr.	Reading Value		Emission Level		Limit		Margin	
		Factor	[dB (uV)]		[dB (uV)]		[dB (uV)]		(dB)	
	(dB)	Q.P.	AV.	Q.P.	AV.	Q.P.	AV.	Q.P.	AV.	
1	0.15781	9.99	38.87	25.85	48.86	35.84	65.58	55.58	-16.72	-19.74
2	0.18516	9.99	32.92	22.01	42.91	32.00	64.25	54.25	-21.34	-22.25
3	0.22031	9.99	27.46	16.82	37.45	26.81	62.81	52.81	-25.36	-26.00
4	0.24375	9.99	26.67	18.06	36.66	28.05	61.97	51.97	-25.31	-23.92
5	0.28281	9.99	25.45	18.54	35.44	28.53	60.73	50.73	-25.29	-22.20
6	0.32578	10.00	28.10	13.57	38.10	23.57	59.56	49.56	-21.46	-25.99

Remarks:

1. Q.P. and AV. are abbreviations of quasi-peak and average individually.
2. The emission levels of other frequencies were very low against the limit.
3. Margin value = Emission level – Limit value
4. Correction factor = Insertion loss + Cable loss
5. Emission Level = Correction Factor + Reading Value

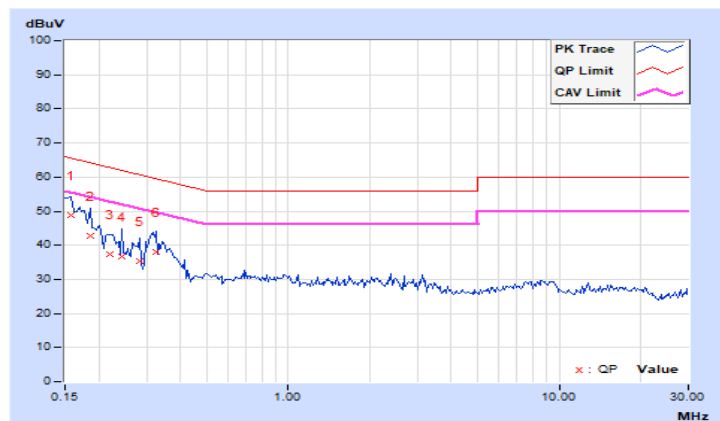

Phase	Neutral (N)	Detector Function	Quasi-Peak (QP) / Average (AV)
-------	-------------	-------------------	--------------------------------

No	Freq. [MHz]	Corr.	Reading Value		Emission Level		Limit		Margin	
		Factor	[dB (uV)]		[dB (uV)]		[dB (uV)]		(dB)	
	(dB)	Q.P.	AV.	Q.P.	AV.	Q.P.	AV.	Q.P.	AV.	
1	0.15781	9.99	39.19	25.30	49.18	35.29	65.58	55.58	-16.40	-20.29
2	0.17734	9.99	34.85	21.93	44.84	31.92	64.61	54.61	-19.77	-22.69
3	0.20469	9.99	31.56	20.43	41.55	30.42	63.42	53.42	-21.87	-23.00
4	0.23203	9.99	29.37	18.15	39.36	28.14	62.38	52.38	-23.02	-24.24
5	0.31016	10.00	32.22	25.43	42.22	35.43	59.97	49.97	-17.75	-14.54
6	3.38672	10.19	12.08	3.00	22.27	13.19	56.00	46.00	-33.73	-32.81

Remarks:

1. Q.P. and AV. are abbreviations of quasi-peak and average individually.
2. The emission levels of other frequencies were very low against the limit.
3. Margin value = Emission level – Limit value
4. Correction factor = Insertion loss + Cable loss
5. Emission Level = Correction Factor + Reading Value

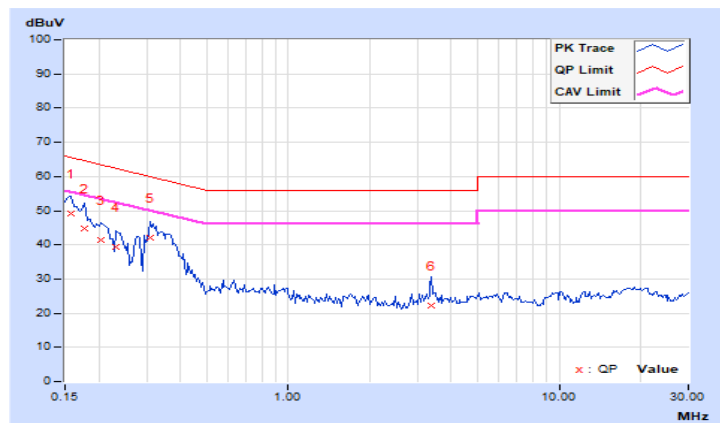

4.3 Transmit Power Measurement

4.3.1 Limits of Transmit Power Measurement

Operation Band	EUT Category		Limit
U-NII-1		Outdoor Access Point	1 Watt (30 dBm) (Max. e.i.r.p \leq 125mW(21 dBm) at any elevation angle above 30 degrees as measured from the horizon)
		Fixed point-to-point Access Point	1 Watt (30 dBm)
	√	Indoor Access Point	1 Watt (30 dBm)
		Client device	250mW (24 dBm)
U-NII-2A			250mW (24 dBm) or 11 dBm+10 log B*
U-NII-2C			250mW (24 dBm) or 11 dBm+10 log B*
U-NII-3		√	1 Watt (30 dBm)

*B is the 26 dB emission bandwidth in megahertz

Per KDB 662911 Method of conducted output power measurement on IEEE 802.11 devices,

Array Gain = 0 dB (i.e., no array gain) for $N_{ANT} \leq 4$;

Array Gain = 0 dB (i.e., no array gain) for channel widths ≥ 40 MHz for any N_{ANT} ;

Array Gain = $5 \log(N_{ANT}/N_{SS})$ dB or 3 dB, whichever is less for 20-MHz channel widths with $N_{ANT} \geq 5$.

For power measurements on all other devices: Array Gain = $10 \log(N_{ANT}/N_{SS})$ dB.

4.3.2 Test Setup

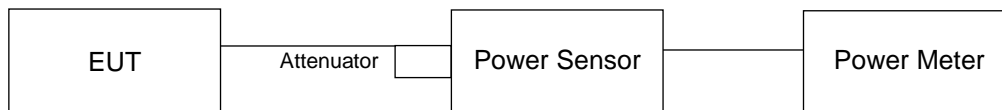

4.3.3 Test Instruments

Refer to section 4.1.2 to get information of above instrument.

4.3.4 Test Procedure

Method PM is used to perform output power measurement, trigger and gating function of wide band power meter is enabled to measure max output power of TX on burst. Duty factor is not added to measured value.

4.3.5 Deviation from Test Standard

No deviation.

4.3.6 EUT Operating Condition

The software provided by client to enable the EUT under transmission condition continuously at lowest, middle and highest channel frequencies individually.

4.3.7 Test Result

Non-Beamforming Mode
802.11a

Chan.	Chan. Freq. (MHz)	Maximum Conducted Power (dBm)				Total Power (mW)	Total Power (dBm)	Limit (dBm)	Pass / Fail
		Chain 0	Chain 1	Chain 2	Chain 3				
36	5180	19.72	19.86	19.23	19.59	365.328	25.63	30.00	Pass
40	5200	19.76	19.92	19.33	19.66	370.973	25.69	30.00	Pass
48	5240	19.81	19.84	19.27	19.68	369.527	25.68	30.00	Pass
149	5745	24.34	23.62	23.54	23.92	974.336	29.89	30.00	Pass
157	5785	24.21	23.54	23.68	24.03	975.853	29.89	30.00	Pass
165	5825	24.06	23.49	23.71	24.11	970.635	29.87	30.00	Pass

802.11ac (VHT20)

Chan.	Chan. Freq. (MHz)	Maximum Conducted Power (dBm)				Total Power (mW)	Total Power (dBm)	Limit (dBm)	Pass / Fail
		Chain 0	Chain 1	Chain 2	Chain 3				
36	5180	19.65	19.61	19.28	19.59	359.382	25.56	30.00	Pass
40	5200	19.54	19.85	19.25	19.63	362.528	25.59	30.00	Pass
48	5240	19.70	19.73	19.19	19.55	360.439	25.57	30.00	Pass
149	5745	24.04	23.28	23.76	23.82	945.002	29.75	30.00	Pass
157	5785	23.97	23.18	23.67	24.01	942.006	29.74	30.00	Pass
165	5825	23.88	23.24	23.71	23.97	939.628	29.73	30.00	Pass

802.11ac (VHT40)

Chan.	Chan. Freq. (MHz)	Maximum Conducted Power (dBm)				Total Power (mW)	Total Power (dBm)	Limit (dBm)	Pass / Fail
		Chain 0	Chain 1	Chain 2	Chain 3				
38	5190	19.24	19.11	18.63	18.96	317.067	25.01	30.00	Pass
46	5230	23.13	22.58	22.41	22.38	733.886	28.66	30.00	Pass
151	5755	23.49	23.44	23.52	23.62	899.206	29.54	30.00	Pass
159	5795	23.40	23.56	23.41	23.73	901.09	29.55	30.00	Pass

802.11ac (VHT80)

Chan.	Chan. Freq. (MHz)	Maximum Conducted Power (dBm)				Total Power (mW)	Total Power (dBm)	Limit (dBm)	Pass / Fail
		Chain 0	Chain 1	Chain 2	Chain 3				
42	5210	18.61	18.48	17.69	18.02	265.216	24.24	30.00	Pass
155	5775	23.59	23.11	23.03	23.08	837.349	29.23	30.00	Pass

802.11ax (HE20)

Chan.	Chan. Freq. (MHz)	Maximum Conducted Power (dBm)				Total Power (mW)	Total Power (dBm)	Limit (dBm)	Pass / Fail
		Chain 0	Chain 1	Chain 2	Chain 3				
36	5180	19.78	19.77	19.41	19.72	370.955	25.69	30.00	Pass
40	5200	19.68	19.96	19.38	19.77	373.518	25.72	30.00	Pass
48	5240	19.83	19.88	19.31	19.69	371.857	25.70	30.00	Pass
149	5745	24.18	23.41	23.92	23.98	977.737	29.90	30.00	Pass
157	5785	24.13	23.33	23.76	24.16	972.398	29.88	30.00	Pass
165	5825	24.03	23.37	23.86	24.12	971.646	29.88	30.00	Pass

802.11ax (HE40)

Chan.	Chan. Freq. (MHz)	Maximum Conducted Power (dBm)				Total Power (mW)	Total Power (dBm)	Limit (dBm)	Pass / Fail
		Chain 0	Chain 1	Chain 2	Chain 3				
38	5190	19.38	19.27	18.76	19.08	327.296	25.15	30.00	Pass
46	5230	23.27	22.73	22.56	22.53	759.186	28.80	30.00	Pass
151	5755	23.62	23.58	23.64	23.77	927.616	29.67	30.00	Pass
159	5795	23.54	23.69	23.59	23.84	930.491	29.69	30.00	Pass

802.11ax (HE80)

Chan.	Chan. Freq. (MHz)	Maximum Conducted Power (dBm)				Total Power (mW)	Total Power (dBm)	Limit (dBm)	Pass / Fail
		Chain 0	Chain 1	Chain 2	Chain 3				
42	5210	18.75	18.62	17.83	18.18	274.207	24.38	30.00	Pass
155	5775	23.73	23.24	23.17	23.21	863.813	29.36	30.00	Pass

Beamforming Mode

802.11ac (VHT20)

Chan.	Chan. Freq. (MHz)	Maximum Conducted Power (dBm)				Total Power (mW)	Total Power (dBm)	Limit (dBm)	Pass / Fail
		Chain 0	Chain 1	Chain 2	Chain 3				
36	5180	19.65	19.61	19.28	19.59	359.382	25.56	25.86	Pass
40	5200	19.54	19.85	19.25	19.63	362.528	25.59	25.86	Pass
48	5240	19.70	19.73	19.19	19.55	360.439	25.57	25.86	Pass
149	5745	19.91	19.42	19.38	19.76	366.767	25.64	25.86	Pass
157	5785	19.97	19.37	19.51	19.78	370.2	25.68	25.86	Pass
165	5825	19.99	19.48	19.53	19.67	370.912	25.69	25.86	Pass

Note: 1. Directional gain = $10 \log[(10^{G1/20} + 10^{G2/20} + 10^{G3/20} + 10^{G4/20})^2 / 4] = 10.14\text{dBi} > 6\text{dBi}$, so the power limit shall be reduced to $30 - (10.14 - 6) = 25.86 \text{ dBm}$.

802.11ac (VHT40)

Chan.	Chan. Freq. (MHz)	Maximum Conducted Power (dBm)				Total Power (mW)	Total Power (dBm)	Limit (dBm)	Pass / Fail
		Chain 0	Chain 1	Chain 2	Chain 3				
38	5190	19.24	19.11	18.63	18.96	317.067	25.01	25.86	Pass
46	5230	19.60	19.53	19.15	19.49	352.088	25.47	25.86	Pass
151	5755	19.51	19.70	19.19	19.97	364.953	25.62	25.86	Pass
159	5795	19.59	19.64	19.13	19.98	364.423	25.62	25.86	Pass

Note: 1. Directional gain = $10 \log[(10^{G1/20} + 10^{G2/20} + 10^{G3/20} + 10^{G4/20})^2 / 4] = 10.14\text{dBi} > 6\text{dBi}$, so the power limit shall be reduced to $30 - (10.14 - 6) = 25.86 \text{ dBm}$.

802.11ac (VHT80)

Chan.	Chan. Freq. (MHz)	Maximum Conducted Power (dBm)				Total Power (mW)	Total Power (dBm)	Limit (dBm)	Pass / Fail
		Chain 0	Chain 1	Chain 2	Chain 3				
42	5210	18.61	18.48	17.69	18.02	265.216	24.24	25.86	Pass
155	5775	19.59	19.16	19.08	19.47	342.827	25.35	25.86	Pass

Note: 1. Directional gain = $10 \log[(10^{G1/20} + 10^{G2/20} + 10^{G3/20} + 10^{G4/20})^2 / 4] = 10.14\text{dBi} > 6\text{dBi}$, so the power limit shall be reduced to $30 - (10.14 - 6) = 25.86 \text{ dBm}$.

802.11ax (HE20)

Chan.	Chan. Freq. (MHz)	Maximum Conducted Power (dBm)				Total Power (mW)	Total Power (dBm)	Limit (dBm)	Pass / Fail
		Chain 0	Chain 1	Chain 2	Chain 3				
36	5180	19.78	19.77	19.41	19.72	370.955	25.69	25.86	Pass
40	5200	19.68	19.96	19.38	19.77	373.518	25.72	25.86	Pass
48	5240	19.83	19.88	19.31	19.69	371.857	25.70	25.86	Pass
149	5745	20.02	19.54	19.51	19.86	376.571	25.76	25.86	Pass
157	5785	20.11	19.52	19.64	19.91	382.095	25.82	25.86	Pass
165	5825	20.06	19.61	19.68	19.80	381.198	25.81	25.86	Pass

Note: 1. Directional gain = $10 \log[(10^{G1/20} + 10^{G2/20} + 10^{G3/20} + 10^{G4/20})^2 / 4] = 10.14\text{dBi} > 6\text{dBi}$, so the power limit shall be reduced to $30-(10.14-6) = 25.86$ dBm.

802.11ax (HE40)

Chan.	Chan. Freq. (MHz)	Maximum Conducted Power (dBm)				Total Power (mW)	Total Power (dBm)	Limit (dBm)	Pass / Fail
		Chain 0	Chain 1	Chain 2	Chain 3				
38	5190	19.38	19.27	18.76	19.08	327.296	25.15	25.86	Pass
46	5230	19.73	19.65	19.32	19.62	363.358	25.60	25.86	Pass
151	5755	19.66	19.83	19.34	20.11	377.097	25.76	25.86	Pass
159	5795	19.72	19.79	19.28	20.06	375.15	25.74	25.86	Pass

Note: 1. Directional gain = $10 \log[(10^{G1/20} + 10^{G2/20} + 10^{G3/20} + 10^{G4/20})^2 / 4] = 10.14\text{dBi} > 6\text{dBi}$, so the power limit shall be reduced to $30-(10.14-6) = 25.86$ dBm.

802.11ax (HE80)

Chan.	Chan. Freq. (MHz)	Maximum Conducted Power (dBm)				Total Power (mW)	Total Power (dBm)	Limit (dBm)	Pass / Fail
		Chain 0	Chain 1	Chain 2	Chain 3				
42	5210	18.75	18.62	17.83	18.18	274.207	24.38	25.86	Pass
155	5775	19.72	19.31	19.25	19.61	354.617	25.50	25.86	Pass

Note: 1. Directional gain = $10 \log[(10^{G1/20} + 10^{G2/20} + 10^{G3/20} + 10^{G4/20})^2 / 4] = 10.14\text{dBi} > 6\text{dBi}$, so the power limit shall be reduced to $30-(10.14-6) = 25.86$ dBm.

4.4 Occupied Bandwidth Measurement

4.4.1 Test Setup



4.4.2 Test Instruments

Refer to section 4.1.2 to get information of above instrument.

4.4.3 Test Procedure

The transmitter output was connected to the spectrum analyzer through an attenuator. The bandwidth of the fundamental frequency was measured by spectrum analyzer with resolution bandwidth in the range of 1% to 5% of the anticipated emission bandwidth, and a video bandwidth at least 3x the resolution bandwidth and set the detector to SAMPLE. The width of a frequency band such that, below the lower and above the upper frequency limits, the mean powers emitted are each equal to a specified percentage 0.5% of the total mean power of a given emission.

4.4.4 Test Results

802.11a

Channel	Channel Frequency (MHz)	Occupied Bandwidth (MHz)			
		Chain 0	Chain 1	Chain 2	Chain 3
36	5180	16.92	17.04	17.04	16.80
40	5200	16.92	17.16	17.04	16.92
48	5240	16.92	16.80	17.04	16.92
149	5745	17.40	17.04	17.16	17.04
157	5785	17.40	17.28	17.40	17.28
165	5825	17.40	17.28	17.28	17.16

802.11ax (HE20)

Channel	Channel Frequency (MHz)	Occupied Bandwidth (MHz)			
		Chain 0	Chain 1	Chain 2	Chain 3
36	5180	19.08	18.12	19.08	19.08
40	5200	19.08	19.08	19.08	19.08
48	5240	19.08	18.00	19.08	19.08
149	5745	19.20	19.20	19.08	19.08
157	5785	18.36	19.20	19.20	19.32
165	5825	18.36	19.32	19.32	19.20

802.11ax (HE40)

Channel	Channel Frequency (MHz)	Occupied Bandwidth (MHz)			
		Chain 0	Chain 1	Chain 2	Chain 3
38	5190	36.72	37.68	36.72	37.92
46	5230	38.16	38.16	37.92	37.92
151	5755	38.16	38.40	38.16	38.16
159	5795	38.16	38.40	38.40	38.16

802.11ax (HE80)

Channel	Channel Frequency (MHz)	Occupied Bandwidth (MHz)			
		Chain 0	Chain 1	Chain 2	Chain 3
42	5210	77.28	77.76	77.28	77.28
155	5775	77.76	77.76	77.76	77.28

Spectrum Plot of Max. Value

802.11a_Chain 0 / CH149

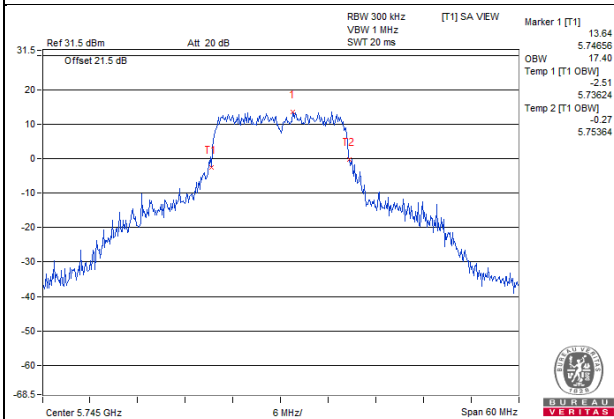

802.11ax (HE20)_Chain 1 / CH165

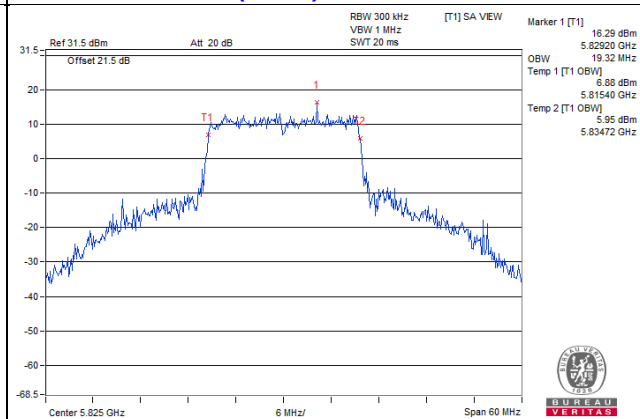

802.11ax (HE40)_Chain 1 / CH151

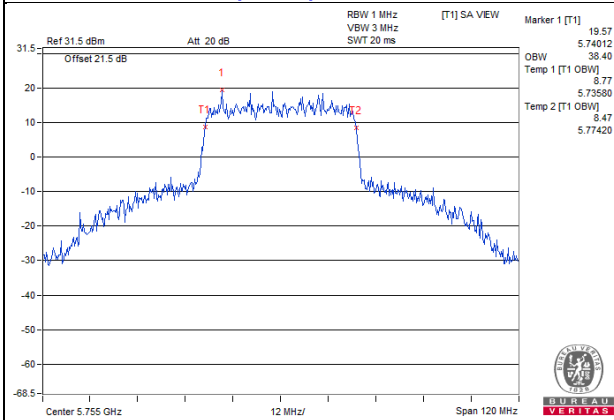

802.11ax (HE80)_Chain 0 / CH155

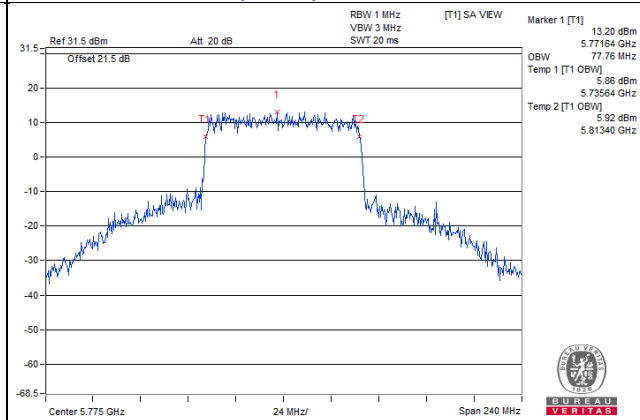

Spectrum Plot for near by DFS band
(DFS is required, if 99% OCP straddle into U-NII-2A band)

802.11a_Chain 0 / CH48

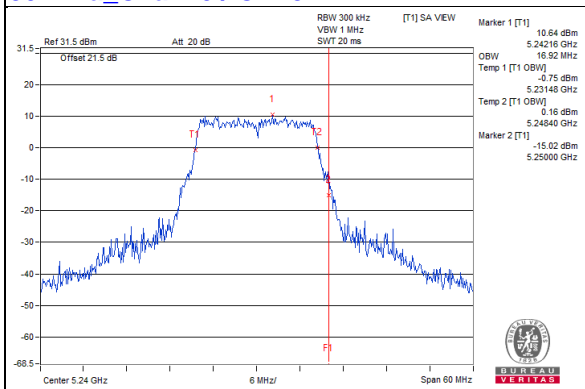

802.11a_Chain 1 / CH48

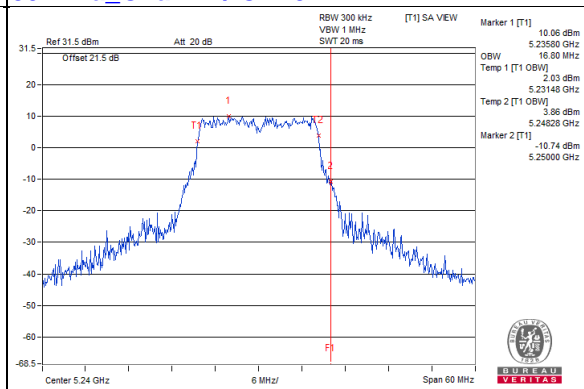

802.11a_Chain 2 / CH48

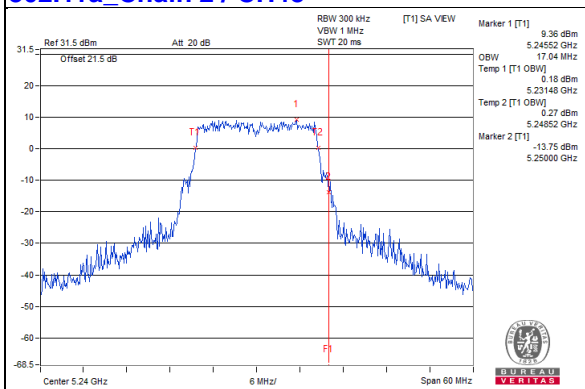

802.11a_Chain 3 / CH48

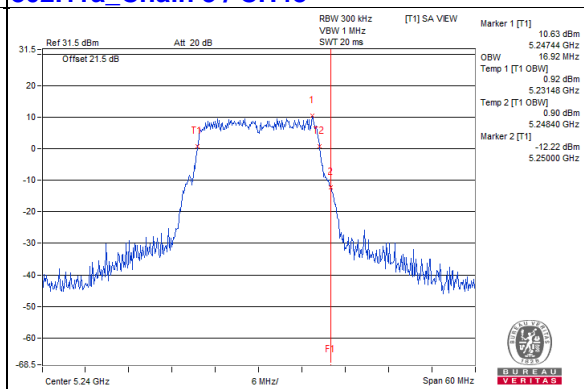

802.11ax (HE20)_Chain 0 / CH48

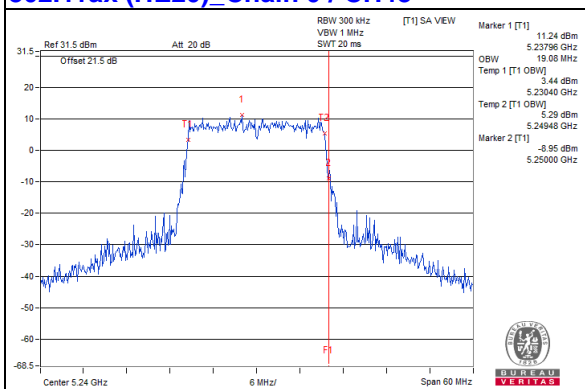

802.11ax (HE20)_Chain 1 / CH48

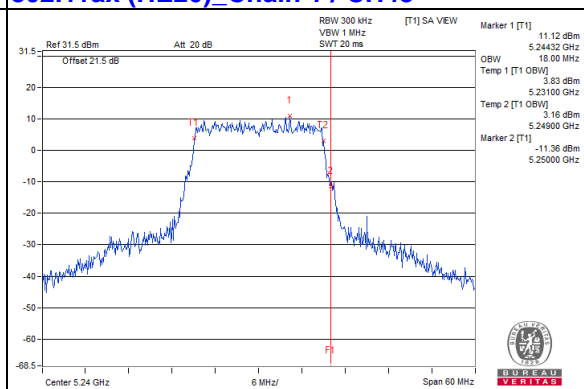

802.11ax (HE20)_Chain 2 / CH48

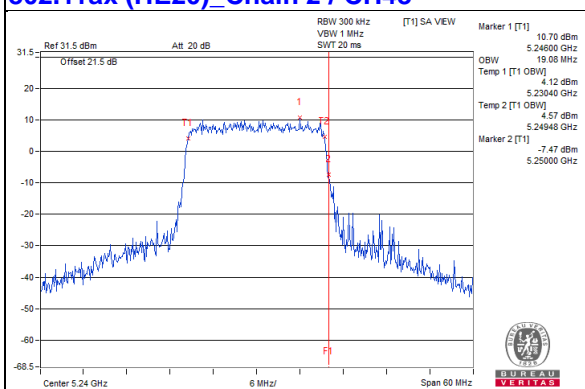

802.11ax (HE20)_Chain 3 / CH48

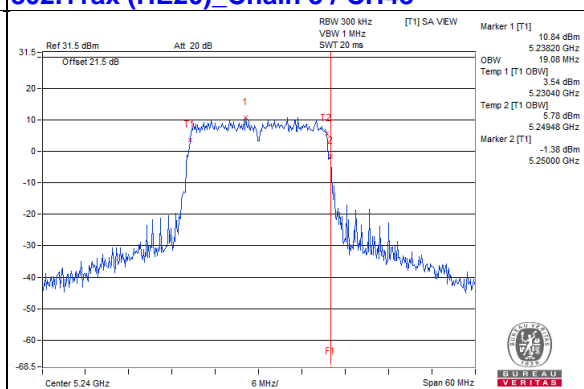

Spectrum Plot for near by DFS band
(DFS is required, if 99% OCP straddle into U-NII-2A band)

802.11ax (HE40)_Chain 0 / CH46

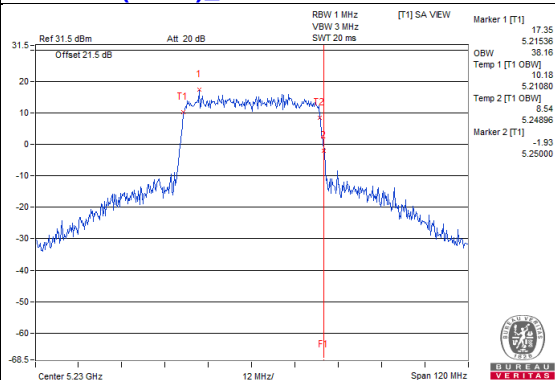

802.11ax (HE40)_Chain 1 / CH46

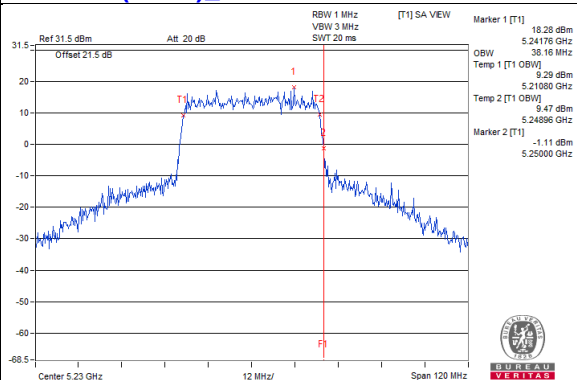

802.11ax (HE40)_Chain 2 / CH46

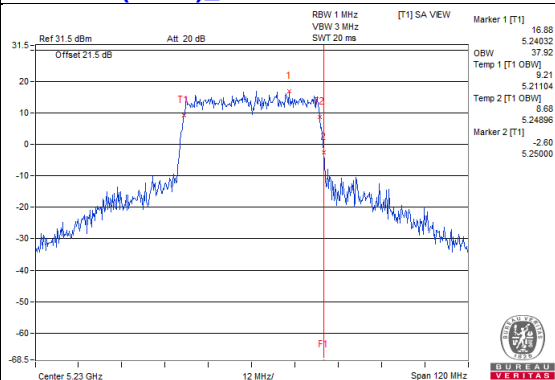

802.11ax (HE40)_Chain 3 / CH46

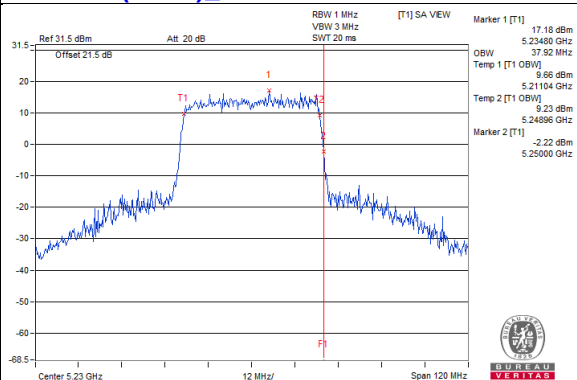

802.11ax (HE80)_Chain 0 / CH42

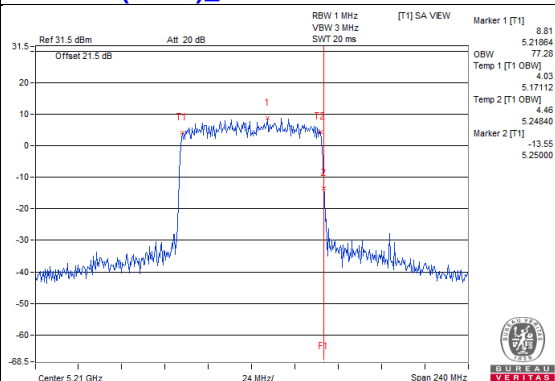

802.11ax (HE80)_Chain 1 / CH42

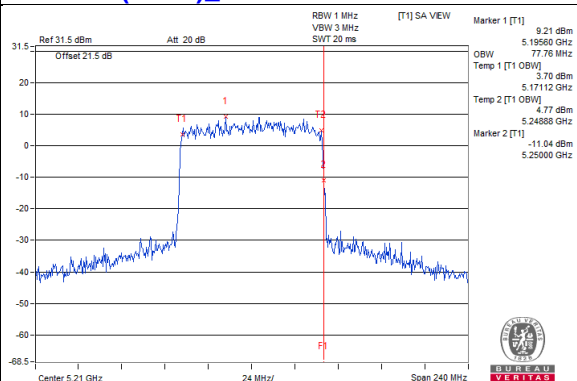

802.11ax (HE80)_Chain 2 / CH42

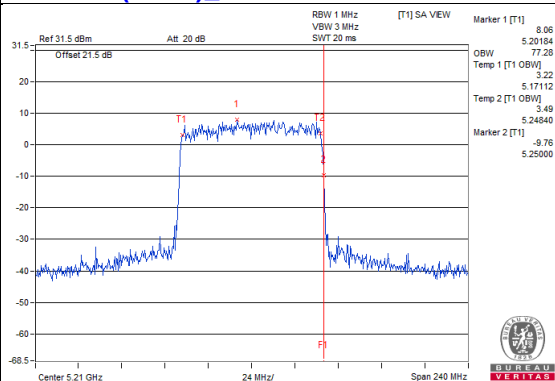

802.11ax (HE80)_Chain 3 / CH42

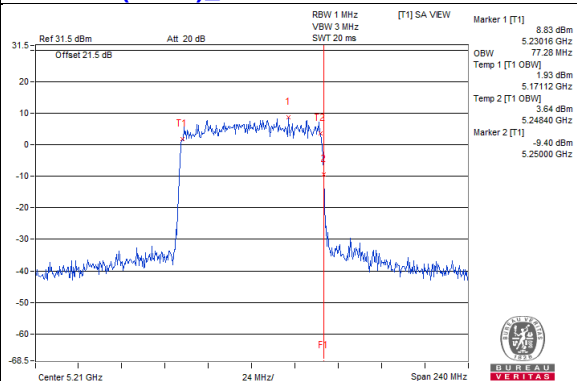

**Spectrum Plot for near by DFS band
(DFS is required, if 99% OCP straddle into U-NII-2C band)**

802.11a_Chain 0 / CH149

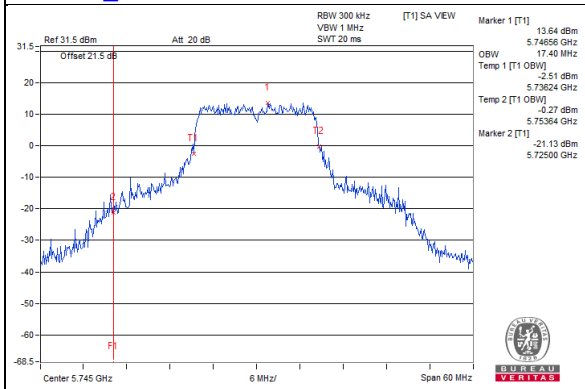

802.11a_Chain 1 / CH149

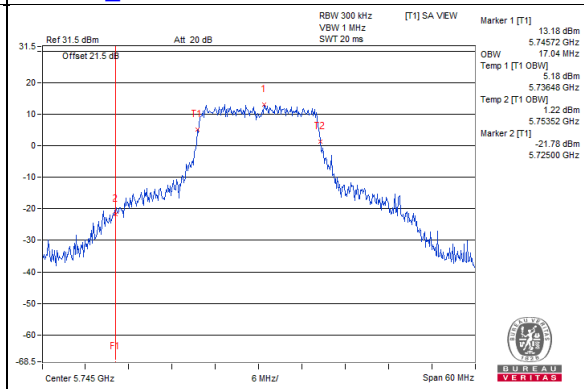

802.11a_Chain 2 / CH149

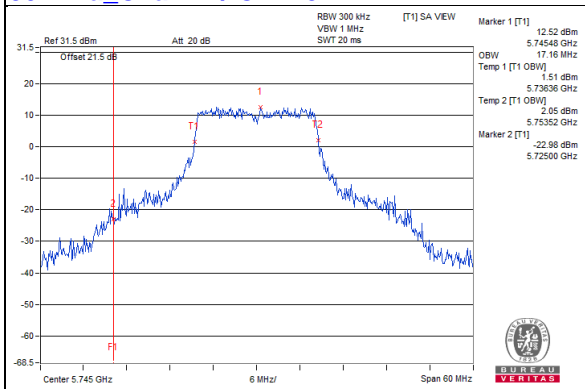

802.11a_Chain 3 / CH149

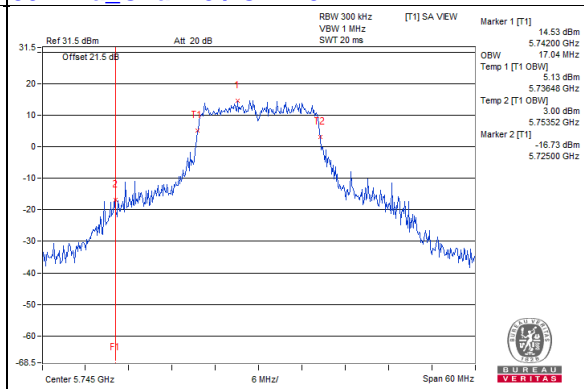

802.11ax (HE20)_Chain 0 / CH149

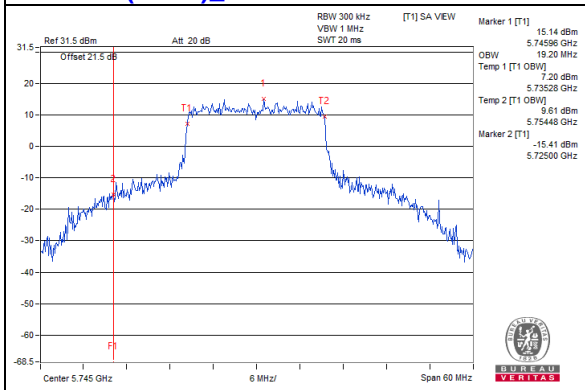

802.11ax (HE20)_Chain 1 / CH149

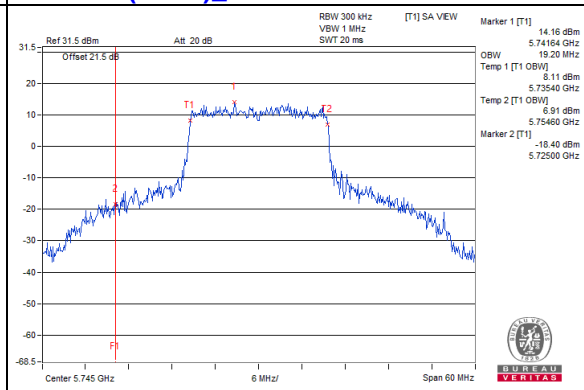

802.11ax (HE20)_Chain 2 / CH149

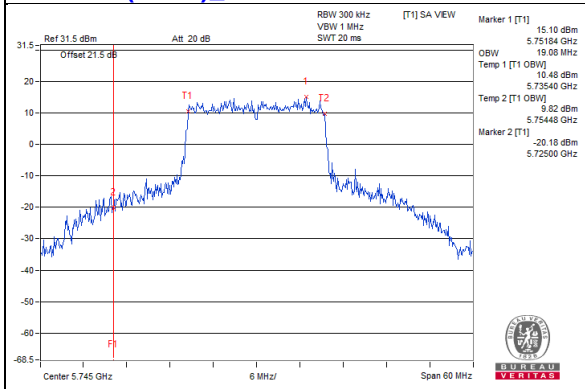

802.11ax (HE20)_Chain 3 / CH149

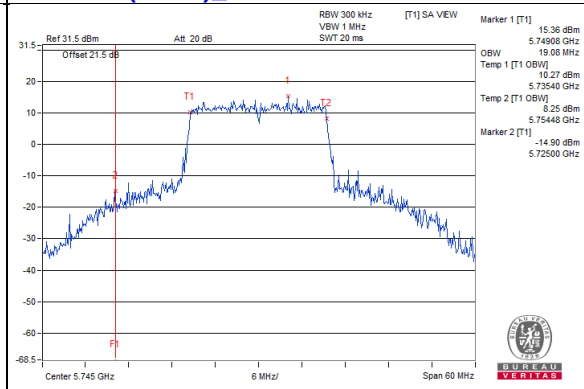

**Spectrum Plot for near by DFS band
(DFS is required, if 99% OCP straddle into U-NII-2C band)**

802.11ax (HE40)_Chain 0 / CH151

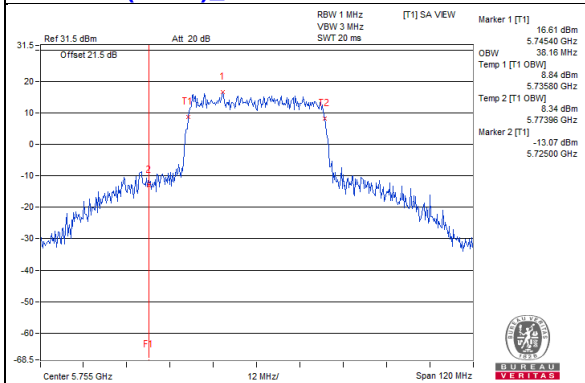

802.11ax (HE40)_Chain 1 / CH151

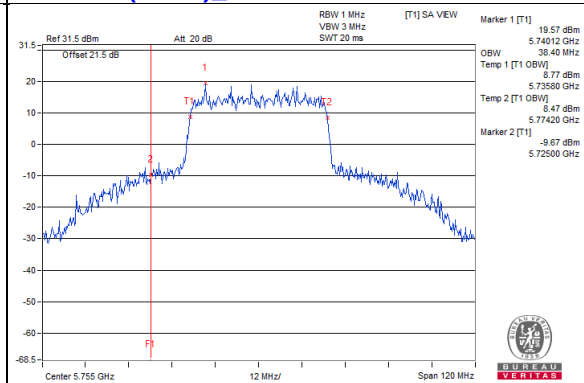

802.11ax (HE40)_Chain 2 / CH151

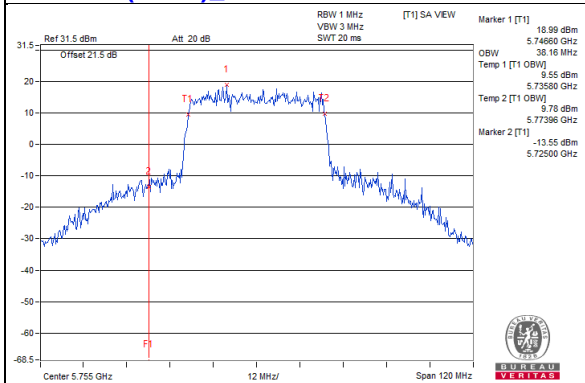

802.11ax (HE40)_Chain 3 / CH151

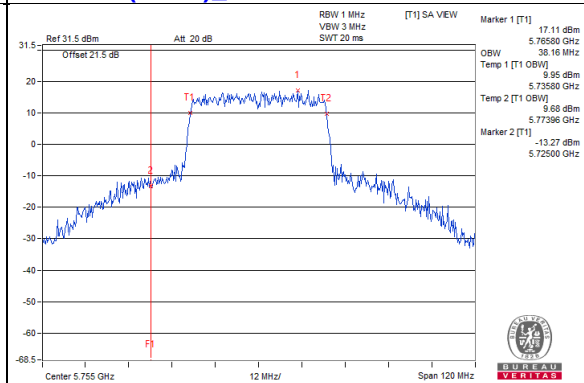

802.11ax (HE80)_Chain 0 / CH155

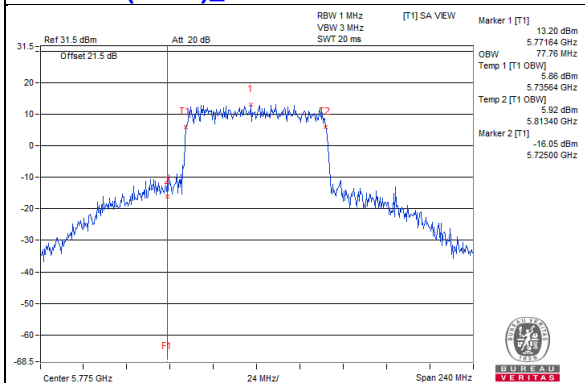

802.11ax (HE80)_Chain 1 / CH155

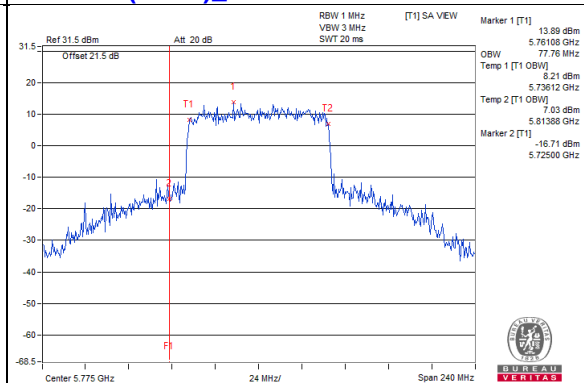

802.11ax (HE80)_Chain 2 / CH155

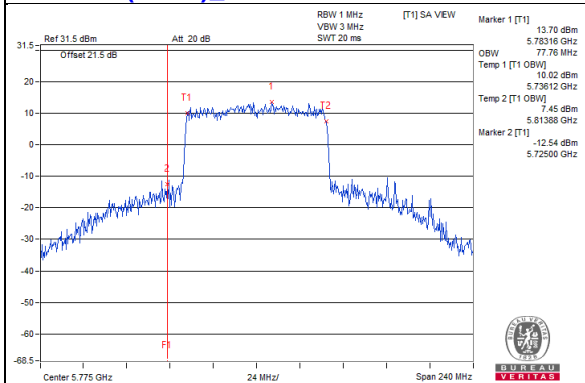

802.11ax (HE80)_Chain 3 / CH155

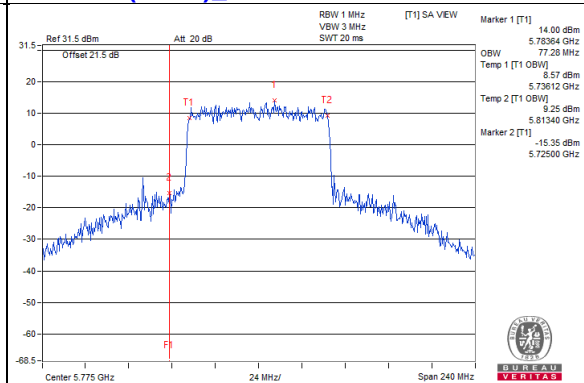

4.5 Peak Power Spectral Density Measurement

4.5.1 Limits of Peak Power Spectral Density Measurement

Operation Band	EUT Category		Limit
U-NII-1		Outdoor Access Point	17dBm/ MHz
		Fixed point-to-point Access Point	
	√	Indoor Access Point	
		Client device	11dBm/ MHz
U-NII-2A			11dBm/ MHz
U-NII-2C			11dBm/ MHz
U-NII-3		√	30dBm/ 500kHz

4.5.2 Test Setup

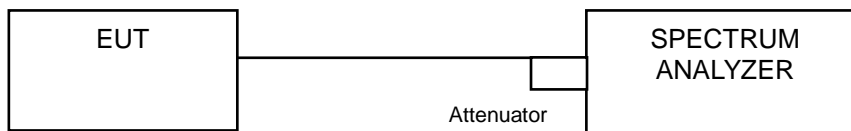

4.5.3 Test Instruments

Refer to section 4.1.2 to get information of above instrument.

4.5.4 Test Procedure

For 802.11a:

For U-NII-1:

Using method SA-1

1. Set span to encompass the entire emission bandwidth (EBW) of the signal.
2. Set RBW = 1 MHz, Set VBW ≥ 3 MHz, Detector = RMS
3. Sweep time = auto, trigger set to "free run".
4. Trace average at least 100 traces in power averaging mode.
5. Record the max value

For U-NII-3:

1. Set span to encompass the entire emission bandwidth (EBW) of the signal.
2. Set RBW = 300 kHz, Set VBW ≥ 1 MHz, Detector = RMS
3. Use the peak marker function to determine the maximum power level in any 300 kHz band segment within the fundamental EBW.
4. Scale the observed power level to an equivalent value in 500 kHz by adjusting (reducing) the measured power by a bandwidth correction factor (BWCF) where $BWCF = 10\log(500\text{ kHz}/300\text{ kHz})$
5. Sweep time = auto, trigger set to "free run".
6. Trace average at least 100 traces in power averaging mode.
7. Record the max value

For other modulation:

For U-NII-1:

Using method SA-2

1. Set span to encompass the entire emission bandwidth (EBW) of the signal.
2. Set RBW = 1 MHz, Set VBW \geq 3 MHz, Detector = RMS
3. Sweep time = auto, trigger set to "free run".
4. Trace average at least 100 traces in power averaging mode.
5. Record the max value and add 10 log (1/duty cycle)

For U-NII-3:

1. Set span to encompass the entire emission bandwidth (EBW) of the signal.
2. Set RBW = 300 kHz, Set VBW \geq 1 MHz, Detector = RMS
3. Use the peak marker function to determine the maximum power level in any 300 kHz band segment within the fundamental EBW.
4. Scale the observed power level to an equivalent value in 500 kHz by adjusting (reducing) the measured power by a bandwidth correction factor (BWCF) where $BWCF = 10\log(500 \text{ kHz}/300\text{kHz})$
5. Sweep time = auto, trigger set to "free run".
6. Trace average at least 100 traces in power averaging mode.
7. Record the max value and add 10 log (1/duty cycle)

4.5.5 Deviation from Test Standard

No deviation.

4.5.6 EUT Operating Condition

Same as Item 4.3.6.

4.5.7 Test Results

For U-NII-1:

802.11a

Chan.	Chan. Freq. (MHz)	PSD (dBm/MHz)				Total Power Density (dBm/MHz)	MAX. Limit (dBm/MHz)	Pass / Fail
		Chain 0	Chain 1	Chain 2	Chain 3			
36	5180	5.62	5.71	5.62	5.63	11.67	12.86	Pass
40	5200	6.09	5.94	5.67	5.82	11.90	12.86	Pass
48	5240	5.85	6.27	5.50	5.77	11.88	12.86	Pass

- Note:** 1. Method a) of power density measurement of KDB 662911 is using for calculating total power density. Total power density is summing entire spectra across corresponding frequency bins on the various outputs by computer.
2. Directional gain = $10 \log[(10^{G1/20} + 10^{G2/20} + 10^{G3/20} + 10^{G4/20})^2 / 4] = 10.14\text{dBi} > 6\text{dBi}$, so the Power Density limit shall be reduced to $17-(10.14-6) = 12.86\text{dBm}$

802.11ax (HE20)

Chan.	Chan. Freq. (MHz)	PSD W/O Duty Factor (dBm/MHz)				Duty Factor (dB)	Total PSD With Duty Factor (dBm/MHz)	Max. Limit (dBm/MHz)	Pass / Fail
		Chain 0	Chain 1	Chain 2	Chain 3				
36	5180	4.92	5.48	5.20	5.39	0.12	11.39	12.86	Pass
40	5200	5.08	5.64	5.32	5.41	0.12	11.51	12.86	Pass
48	5240	5.24	5.71	5.24	5.33	0.12	11.53	12.86	Pass

- Note:** 1. Method a) of power density measurement of KDB 662911 is using for calculating total power density. Total power density is summing entire spectra across corresponding frequency bins on the various outputs by computer.
2. Directional gain = $10 \log[(10^{G1/20} + 10^{G2/20} + 10^{G3/20} + 10^{G4/20})^2 / 4] = 10.14\text{dBi} > 6\text{dBi}$, so the Power Density limit shall be reduced to $17-(10.14-6) = 12.86\text{dBm}$
3. Refer to section 3.3 for duty cycle spectrum plot.

802.11ax (HE40)

Chan.	Chan. Freq. (MHz)	PSD W/O Duty Factor (dBm/MHz)				Duty Factor (dB)	Total PSD With Duty Factor (dBm/MHz)	Max. Limit (dBm/MHz)	Pass / Fail
		Chain 0	Chain 1	Chain 2	Chain 3				
38	5190	2.20	1.93	1.37	1.87	0.17	8.04	12.86	Pass
46	5230	5.61	5.68	5.87	5.49	0.17	11.86	12.86	Pass

- Note:** 1. Method a) of power density measurement of KDB 662911 is using for calculating total power density. Total power density is summing entire spectra across corresponding frequency bins on the various outputs by computer.
2. Directional gain = $10 \log[(10^{G1/20} + 10^{G2/20} + 10^{G3/20} + 10^{G4/20})^2 / 4] = 10.14\text{dBi} > 6\text{dBi}$, so the Power Density limit shall be reduced to $17-(10.14-6) = 12.86\text{dBm}$
3. Refer to section 3.3 for duty cycle spectrum plot.

802.11ax (HE80)

Chan.	Chan. Freq. (MHz)	PSD W/O Duty Factor (dBm/MHz)				Duty Factor (dB)	Total PSD With Duty Factor (dBm/MHz)	Max. Limit (dBm/MHz)	Pass / Fail
		Chain 0	Chain 1	Chain 2	Chain 3				
42	5210	-1.56	-1.55	-1.86	-1.93	0.33	4.63	12.86	Pass

- Note:**
- Method a) of power density measurement of KDB 662911 is using for calculating total power density. Total power density is summing entire spectra across corresponding frequency bins on the various outputs by computer.
 - Directional gain = $10 \log[(10^{G1/20} + 10^{G2/20} + 10^{G3/20} + 10^{G4/20})^2 / 4] = 10.14\text{dBi} > 6\text{dBi}$, so the Power Density limit shall be reduced to $17 - (10.14 - 6) = 12.86\text{dBm}$
 - Refer to section 3.3 for duty cycle spectrum plot.

Spectrum Plot of Worst Value

802.11a_Chain 1 / CH48

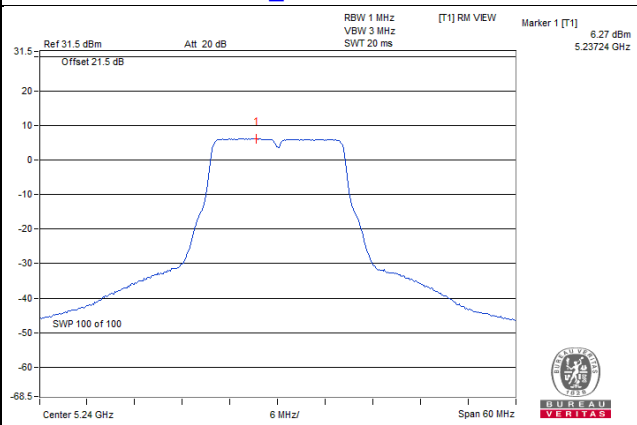

802.11ax (HE20)_Chain 1 / CH48

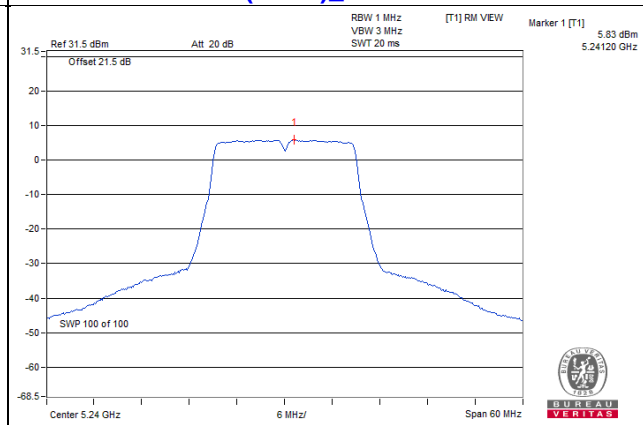

802.11ax (HE40)_Chain 2 / CH46

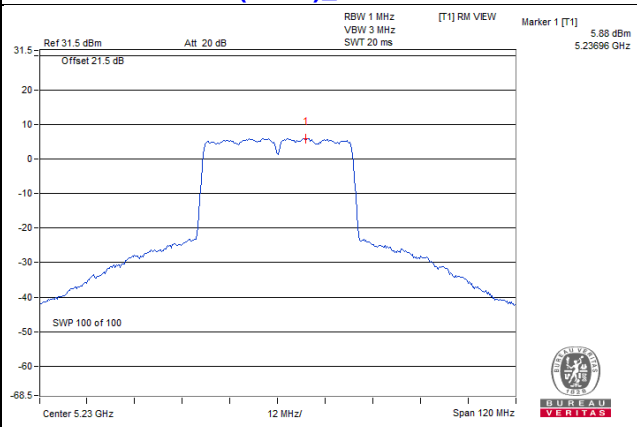

802.11ax (HE80)_Chain 1 / CH42

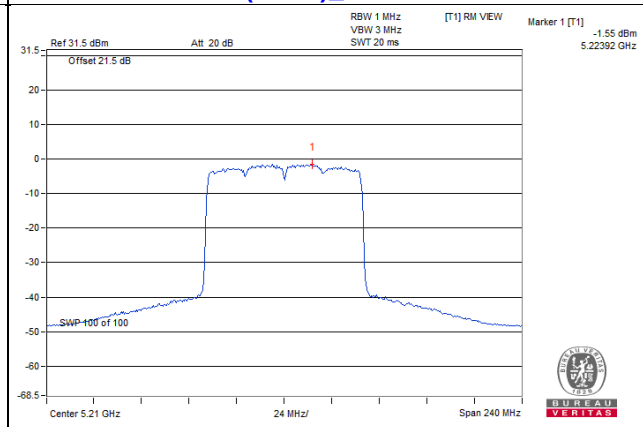

For U-NII-3:
802.11a

Chan.	Freq. (MHz)	PSD (dBm/300kHz)				Total PSD		Total PSD (dBm/500kHz)	Limit (dBm/500kHz)	Pass /Fail
		Chain 0	Chain 1	Chain 2	Chain 3	mW/300kHz	dBm/300kHz			
149	5745	1.78	1.76	1.69	2.01	6.0705	7.83	10.05	25.86	Pass
157	5785	1.81	1.45	1.36	2.52	6.0676	7.83	10.05	25.86	Pass
165	5825	1.69	1.26	1.73	2.63	6.134	7.88	10.10	25.86	Pass

- Note: 1. Method b) Measure and sum spectral maxima across the outputs of KDB 662911 is using for calculating total power density.
 2. Directional gain = $10 \log[(10^{G1/20} + 10^{G2/20} + 10^{G3/20} + 10^{G4/20})^2 / 4] = 10.14\text{dBi} > 6\text{dBi}$, so the Power Density limit shall be reduced to $30 - (10.14 - 6) = 25.86\text{dBm}$

802.11ax (HE20)

Chan.	Freq. (MHz)	PSD W/O Duty Factor (dBm/300kHz)				Duty Factor (dB)	Total PSD With Duty Factor		Total PSD With Duty Factor (dBm/500kHz)	Limit (dBm/500kHz)	Pass /Fail
		Chain 0	Chain 1	Chain 2	Chain 3		mW/300 kHz	dBm/300kHz			
149	5745	1.00	0.07	0.73	0.55	0.12	4.7216	6.74	8.96	25.86	Pass
157	5785	1.65	0.04	0.47	0.89	0.12	4.9477	6.94	9.16	25.86	Pass
165	5825	1.65	0.21	0.53	1.05	0.12	5.0524	7.03	9.25	25.86	Pass

- Note: 1. Method b) Measure and sum spectral maxima across the outputs of KDB 662911 is using for calculating total power density.
 2. Directional gain = $10 \log[(10^{G1/20} + 10^{G2/20} + 10^{G3/20} + 10^{G4/20})^2 / 4] = 10.14\text{dBi} > 6\text{dBi}$, so the Power Density limit shall be reduced to $30 - (10.14 - 6) = 25.86\text{dBm}$
 3. Refer to section 3.3 for duty cycle spectrum plot.

802.11ax (HE40)

Chan.	Freq. (MHz)	PSD W/O Duty Factor (dBm/300kHz)				Duty Factor (dB)	Total PSD With Duty Factor		Total PSD With Duty Factor (dBm/500kHz)	Limit (dBm/500kHz)	Pass /Fail
		Chain 0	Chain 1	Chain 2	Chain 3		mW/300 kHz	dBm/300kHz			
151	5755	-2.41	-2.06	-2.00	-2.12	0.17	2.5392	4.05	6.27	25.86	Pass
159	5795	-2.51	-2.21	-1.87	-1.54	0.17	2.6147	4.17	6.39	25.86	Pass

- Note: 1. Method b) Measure and sum spectral maxima across the outputs of KDB 662911 is using for calculating total power density.
 2. Directional gain = $10 \log[(10^{G1/20} + 10^{G2/20} + 10^{G3/20} + 10^{G4/20})^2 / 4] = 10.14\text{dBi} > 6\text{dBi}$, so the Power Density limit shall be reduced to $30 - (10.14 - 6) = 25.86\text{dBm}$
 3. Refer to section 3.3 for duty cycle spectrum plot.

802.11ax (HE80)

Chan.	Freq. (MHz)	PSD W/O Duty Factor (dBm/300kHz)				Duty Factor (dB)	Total PSD With Duty Factor		Total PSD With Duty Factor (dBm/500kHz)	Limit (dBm/500kHz)	Pass /Fail
		Chain 0	Chain 1	Chain 2	Chain 3		mW/300 kHz	dBm/300kHz			
155	5775	-5.19	-5.82	-4.95	-5.59	0.33	1.2531	0.98	3.20	25.86	Pass

- Note: 1. Method b) Measure and sum spectral maxima across the outputs of KDB 662911 is using for calculating total power density.
2. Directional gain = $10 \log[(10^{G1/20} + 10^{G2/20} + 10^{G3/20} + 10^{G4/20})^2 / 4] = 10.14\text{dBi} > 6\text{dBi}$, so the Power Density limit shall be reduced to $30 - (10.14 - 6) = 25.86\text{dBm}$
3. Refer to section 3.3 for duty cycle spectrum plot.

Spectrum Plot of Worst Value

802.11a_Chain 3 / CH165

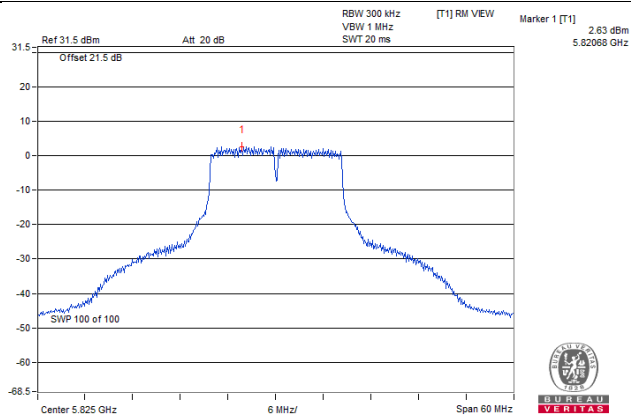

802.11ax (HE20)_Chain 0 / CH157

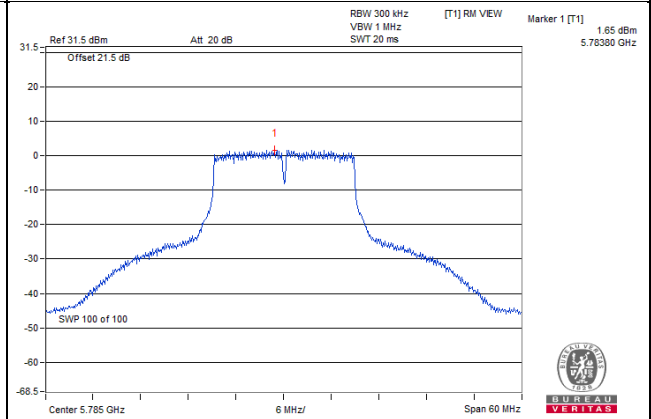

802.11ax (HE40)_Chain 3 / CH159

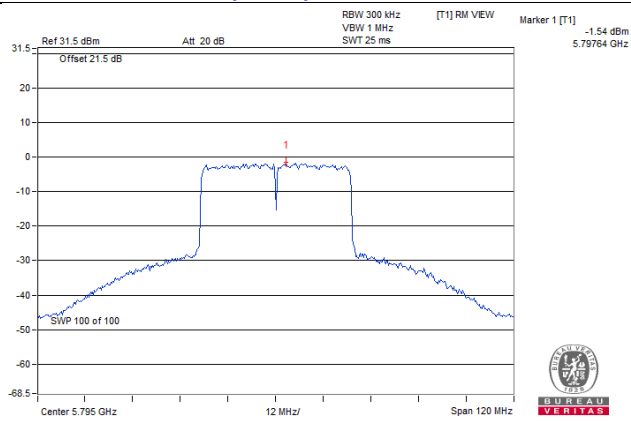

802.11ax (HE80)_Chain 2 / CH155

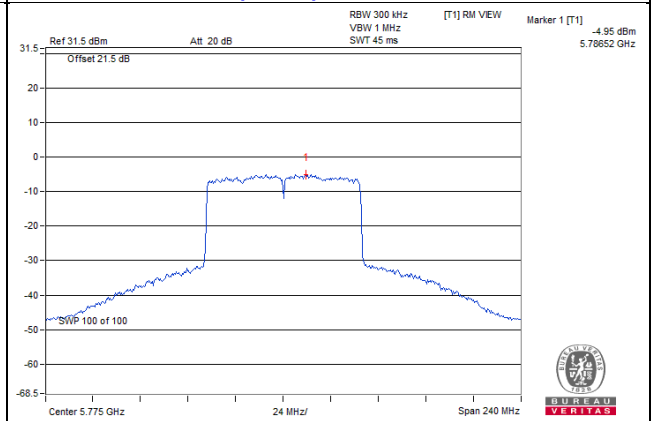

4.6 Frequency Stability Measurement

4.6.1 Limits of Frequency Stability Measurement

The frequency of the carrier signal shall be maintained within band of operation

4.6.2 Test Setup

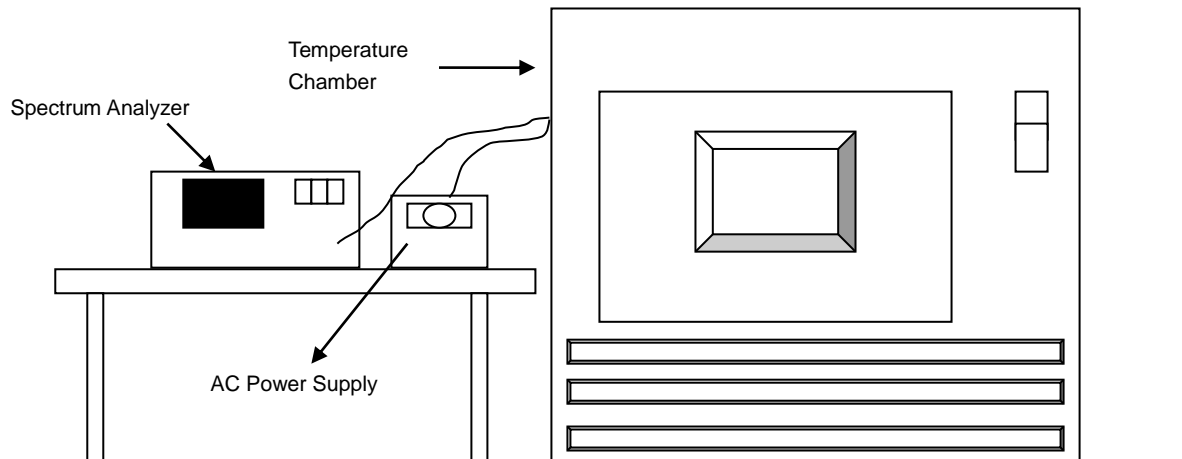

4.6.3 Test Instruments

Refer to section 4.1.2 to get information of above instrument.

4.6.4 Test Procedure

- The EUT was placed inside the environmental test chamber and powered by nominal AC voltage.
- Turn the EUT on and couple its output to a spectrum analyzer.
- Turn the EUT off and set the chamber to the highest temperature specified.
- Allow sufficient time (approximately 30 min) for the temperature of the chamber to stabilize, turn the EUT on and measure the operating frequency after 2, 5, and 10 Minutes.
- Repeat step (d) with the temperature chamber set to the next desired temperature until measurements down to the lowest specified temperature have been completed.
- The test chamber was allowed to stabilize at +20 degree C for a minimum of 30 Minutes. The supply voltage was then adjusted on the EUT from 85% to 115% and the frequency record.

4.6.5 Deviation from Test Standard

No deviation.

4.6.6 EUT Operating Condition

Set the EUT transmit at un-modulation mode to test frequency stability.

4.6.7 Test Results

Frequency Stability Versus Temp.									
Operating Frequency: 5180 MHz									
TEMP. (°C)	Power Supply (Vac)	0 Minute		2 Minutes		5 Minutes		10 Minutes	
		Measured Frequency (MHz)	Pass/Fail	Measured Frequency (MHz)	Pass/Fail	Measured Frequency (MHz)	Pass/Fail	Measured Frequency (MHz)	Pass/Fail
40	120	5179.988	PASS	5179.9883	PASS	5179.9915	PASS	5179.9886	PASS
30	120	5180.0143	PASS	5180.0156	PASS	5180.014	PASS	5180.0162	PASS
20	120	5179.9776	PASS	5179.9778	PASS	5179.9756	PASS	5179.9773	PASS
10	120	5179.9812	PASS	5179.9839	PASS	5179.9818	PASS	5179.9831	PASS
0	120	5179.9939	PASS	5179.9942	PASS	5179.9898	PASS	5179.9911	PASS

Frequency Stability Versus Voltage									
Operating Frequency: 5180 MHz									
TEMP. (°C)	Power Supply (Vac)	0 Minute		2 Minutes		5 Minutes		10 Minutes	
		Measured Frequency (MHz)	Pass/Fail	Measured Frequency (MHz)	Pass/Fail	Measured Frequency (MHz)	Pass/Fail	Measured Frequency (MHz)	Pass/Fail
20	138	5179.9805	PASS	5179.9845	PASS	5179.9817	PASS	5179.9821	PASS
	120	5179.9812	PASS	5179.9839	PASS	5179.9818	PASS	5179.9831	PASS
	102	5179.9816	PASS	5179.9834	PASS	5179.9809	PASS	5179.9831	PASS

4.7 6dB Bandwidth Measurement

4.7.1 Limits of 6dB Bandwidth Measurement

The minimum of 6dB Bandwidth Measurement is 0.5MHz.

4.7.2 Test Setup

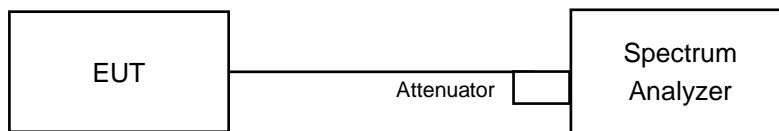

4.7.3 Test Instruments

Refer to section 4.1.2 to get information of above instrument.

4.7.4 Test Procedure

MEASUREMENT PROCEDURE REF

- a. Set resolution bandwidth (RBW) = 100kHz
- b. Set the video bandwidth (VBW) $\geq 3 \times$ RBW, Detector = Peak.
- c. Trace mode = max hold.
- d. Sweep = auto couple.
- e. Measure the maximum width of the emission that is constrained by the frequencies associated with the two amplitude points (upper and lower) that are attenuated by 6 dB relative to the maximum level measured in the fundamental emission

4.7.5 Deviation from Test Standard

No deviation.

4.7.6 EUT Operating Condition

The software provided by client to enable the EUT under transmission condition continuously at lowest, middle and highest channel frequencies individually.

4.7.7 Test Results

802.11a

Channel	Frequency (MHz)	6dB Bandwidth (MHz)				Minimum Limit (MHz)	Pass / Fail
		Chain 0	Chain 1	Chain 2	Chain 3		
149	5745	16.42	16.37	16.40	16.41	0.5	Pass
157	5785	16.43	16.34	16.42	16.40	0.5	Pass
165	5825	16.41	16.34	16.39	16.39	0.5	Pass

802.11ax (HE20)

Channel	Frequency (MHz)	6dB Bandwidth (MHz)				Minimum Limit (MHz)	Pass / Fail
		Chain 0	Chain 1	Chain 2	Chain 3		
149	5745	19.03	18.97	19.01	18.91	0.5	Pass
157	5785	17.66	18.82	19.03	18.92	0.5	Pass
165	5825	17.66	18.83	19.04	18.84	0.5	Pass

802.11ax (HE40)

Channel	Frequency (MHz)	6dB Bandwidth (MHz)				Minimum Limit (MHz)	Pass / Fail
		Chain 0	Chain 1	Chain 2	Chain 3		
151	5755	37.48	37.15	37.66	37.07	0.5	Pass
159	5795	37.47	36.81	37.72	37.16	0.5	Pass

802.11ax (HE80)

Channel	Frequency (MHz)	6dB Bandwidth (MHz)				Minimum Limit (MHz)	Pass / Fail
		Chain 0	Chain 1	Chain 2	Chain 3		
155	5775	76.39	76.24	76.38	75.97	0.5	Pass

Spectrum Plot of Worst Value

802.11a_Chain 1 / CH157

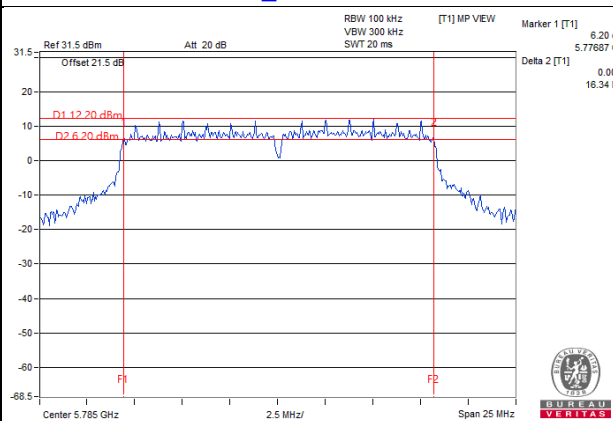

802.11ax (HE20)_Chain 0 / CH157

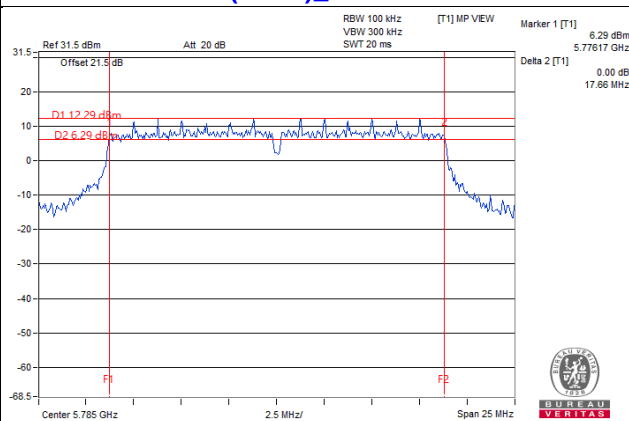

802.11ax (HE40)_Chain 1 / CH159

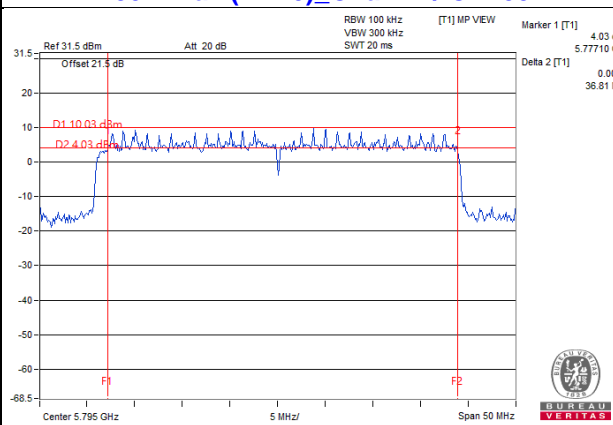

802.11ax (HE80)_Chain 3 / CH155

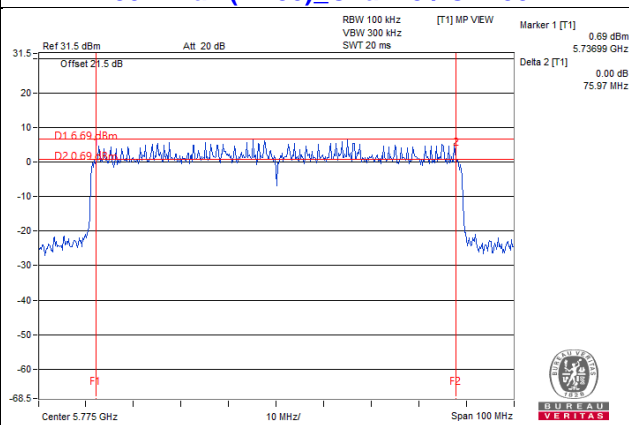

5 Pictures of Test Arrangements

Please refer to the attached file (Test Setup Photo).

Annex A- Radiated Out of Band Emission (OOBE) Measurement (For U-NII-3 band)

802.11a

CH 149 5745 MHz

Horizontal

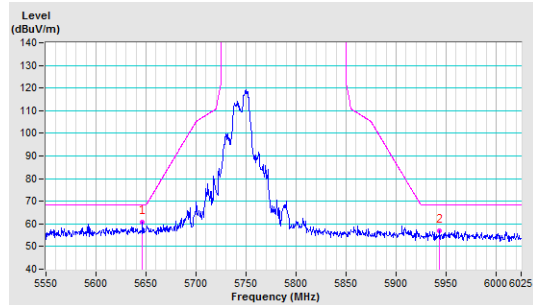

Vertical

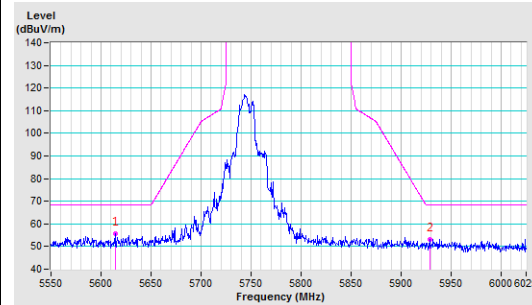

CH 157 5785 MHz

Horizontal

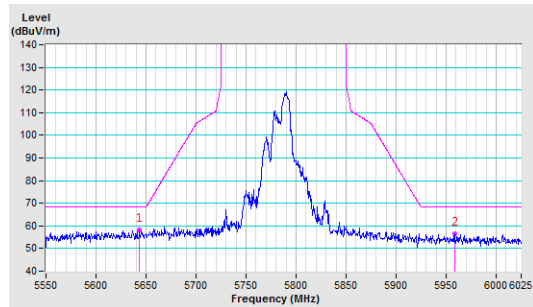

Vertical

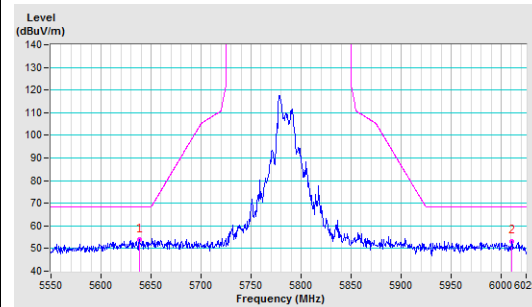

CH 165 5825 MHz

Horizontal

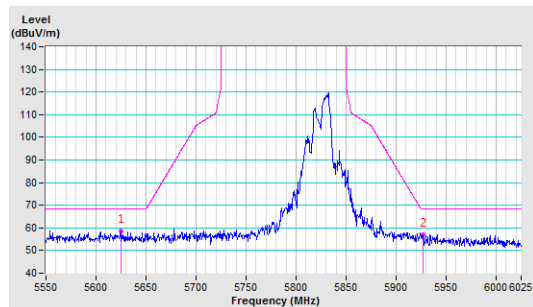

Vertical

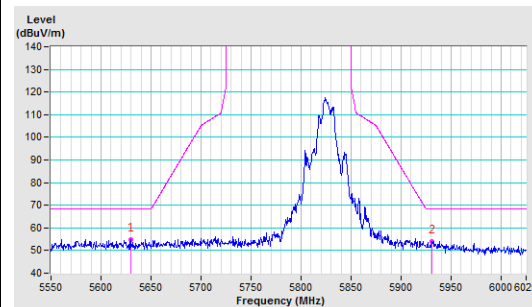

802.11ac (VHT20)

CH 149 5745 MHz

Horizontal

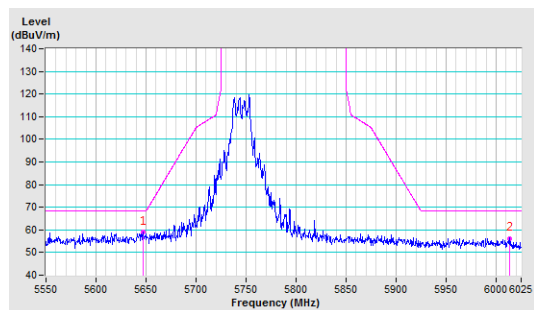

Vertical

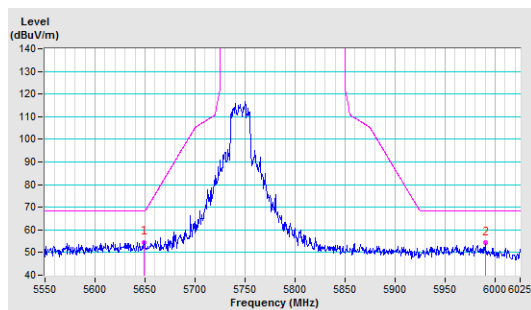

CH 157 5785 MHz

Horizontal

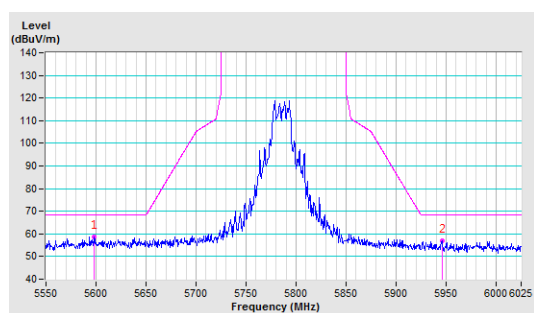

Vertical

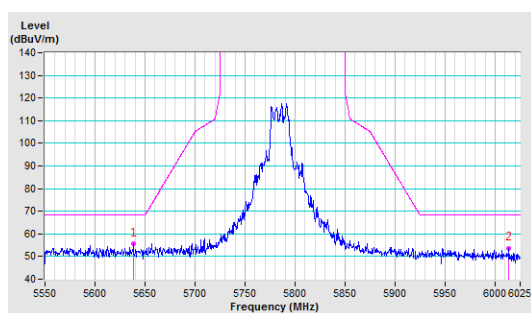

CH 165 5825 MHz

Horizontal

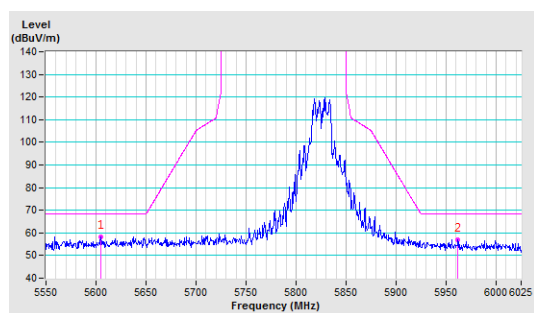

Vertical

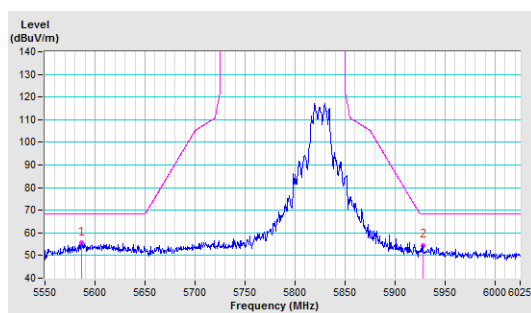

802.11ac (VHT40)

CH 151 5755 MHz

Horizontal

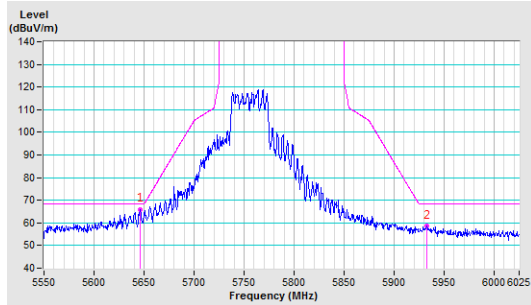

Vertical

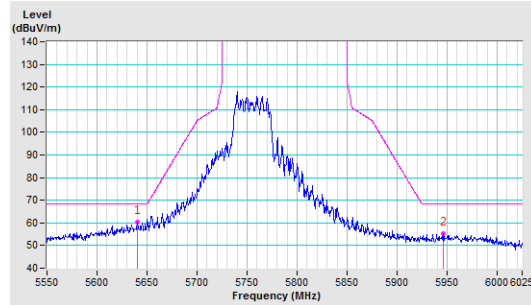

CH 159 5795 MHz

Horizontal

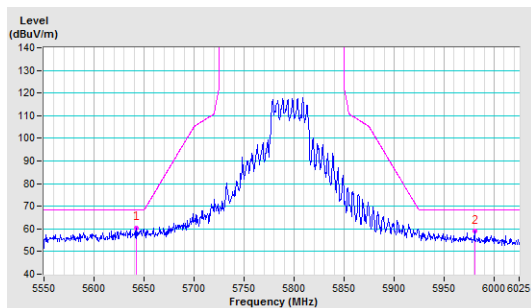

Vertical

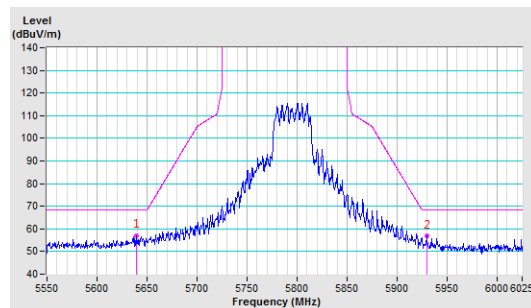

802.11ac (VHT80)

CH 155 5775 MHz

Horizontal

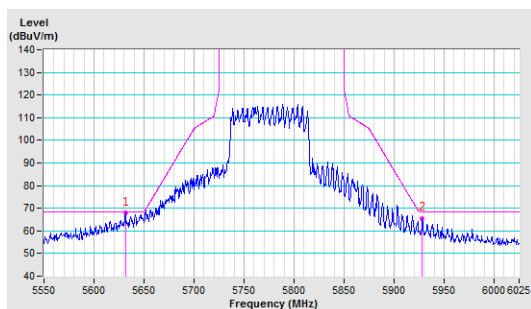

Vertical

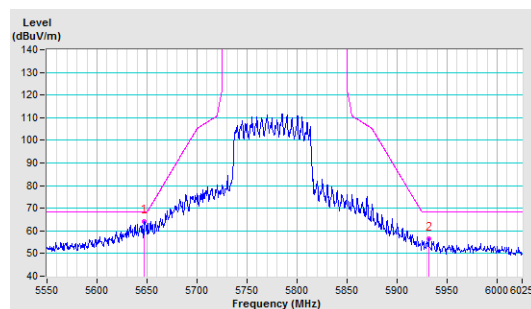

Appendix – Information of the Testing Laboratories

We, Bureau Veritas Consumer Products Services (H.K.) Ltd., Taoyuan Branch, were founded in 1988 to provide our best service in EMC, Radio, Telecom and Safety consultation. Our laboratories are FCC recognized accredited test firms and accredited according to ISO/IEC 17025.

If you have any comments, please feel free to contact us at the following:

Lin Kou EMC/RF Lab

Tel: 886-2-26052180

Fax: 886-2-26051924

Hsin Chu EMC/RF/Telecom Lab

Tel: 886-3-6668565

Fax: 886-3-6668323

Hwa Ya EMC/RF/Safety Lab

Tel: 886-3-3183232

Fax: 886-3-3270892

Email: service.adt@tw.bureauveritas.com

Web Site: www.bureauveritas-adt.com

The address and road map of all our labs can be found in our web site also.

--- END ---