



FCC TEST REPORT (WLAN 15.247)

REPORT NO.: RF141029E01

MODEL NO.: DVW32G

FCC ID: XCNDVW32G

RECEIVED: Oct. 29, 2014

TESTED: Nov. 25 to Dec. 08, 2014

ISSUED: Dec. 23, 2014

APPLICANT: Ubee Interactive Corp.

ADDRESS: 10F-1, No.5, Taiyuan 1st St. Jhubei Hsinchu,
302 Taiwan

ISSUED BY: Bureau Veritas Consumer Products Services
(H.K.) Ltd., Taoyuan Branch Hsin Chu Laboratory

LAB ADDRESS : No. 81-1, Lu Liao Keng, 9th Ling, Wu Lung Tsuen,
Chiung Lin Hsiang, Hsin Chu Hsien 307, Taiwan,
R.O.C.

TEST LOCATION (1): No. 81-1, Lu Liao Keng, 9th Ling, Wu Lung Tsuen,
Chiung Lin Hsiang, Hsin Chu Hsien 307, Taiwan,
R.O.C.

TEST LOCATION (2): No. 49, Ln. 206, Wende Rd., Shangshan Tsuen,
Chiung Lin Hsiang, Hsin Chu Hsien 307, Taiwan,
R.O.C.

This report should not be used by the client to claim product certification, approval, or endorsement by TAF or any government agencies.



This report is for your exclusive use. Any copying or replication of this report to or for any other person or entity, or use of our name or trademark, is permitted only with our prior written permission. This report sets forth our findings solely with respect to the test samples identified herein. The results set forth in this report are not indicative or representative of the quality or characteristics of the lot from which a test sample was taken or any similar or identical product unless specifically and expressly noted. Our report includes all of the tests requested by you and the results thereof based upon the information that you provided to us. You have 60 days from date of issuance of this report to notify us of any material error or omission caused by our negligence, provided, however, that such notice shall be in writing and shall specifically address the issue you wish to raise. A failure to raise such issue within the prescribed time shall constitute your unqualified acceptance of the completeness of this report, the tests conducted and the correctness of the report contents. Unless specific mention, the uncertainty of measurement has been explicitly taken into account to declare the compliance or non-compliance to the specification



A D T

Table of Contents

RELEASE CONTROL RECORD.....	4
1. CERTIFICATION.....	5
2. SUMMARY OF TEST RESULTS.....	6
2.1 MEASUREMENT UNCERTAINTY.....	7
3. GENERAL INFORMATION.....	8
3.1 GENERAL DESCRIPTION OF EUT.....	8
3.2 DESCRIPTION OF TEST MODES.....	11
3.2.1 TEST MODE APPLICABILITY AND TESTED CHANNEL DETAIL.....	12
3.3 GENERAL DESCRIPTION OF APPLIED STANDARDS.....	15
3.4 DUTY CYCLE OF TEST SIGNAL.....	16
3.5 DESCRIPTION OF SUPPORT UNITS.....	17
3.6 CONFIGURATION OF SYSTEM UNDER TEST.....	18
4. TEST TYPES AND RESULTS.....	19
4.1 CONDUCTED EMISSION MEASUREMENT.....	19
4.1.1 LIMITS OF CONDUCTED EMISSION MEASUREMENT.....	19
4.1.2 TEST INSTRUMENTS.....	19
4.1.3 TEST PROCEDURES.....	20
4.1.4 DEVIATION FROM TEST STANDARD.....	20
4.1.5 TEST SETUP.....	20
4.1.6 EUT OPERATING CONDITIONS.....	21
4.1.7 TEST RESULTS.....	22
4.2 RADIATED EMISSION AND BANDEDGE MEASUREMENT.....	24
4.2.1 LIMITS OF RADIATED EMISSION AND BANDEDGE MEASUREMENT.....	24
4.2.2 TEST INSTRUMENTS.....	25
4.2.3 TEST PROCEDURES.....	27
4.2.4 DEVIATION FROM TEST STANDARD.....	27
4.2.5 TEST SETUP.....	28
4.2.6 EUT OPERATING CONDITIONS.....	28
4.2.7 TEST RESULTS (MODE 1).....	29
4.2.8 TEST RESULTS (MODE 2).....	42
4.3 6dB BANDWIDTH MEASUREMENT.....	48
4.3.1 LIMITS OF 6dB BANDWIDTH MEASUREMENT.....	48
4.3.2 TEST INSTRUMENTS.....	48
4.3.3 TEST PROCEDURE.....	48
4.3.4 DEVIATION FROM TEST STANDARD.....	48
4.3.5 TEST SETUP.....	48
4.3.6 EUT OPERATING CONDITIONS.....	48
4.3.7 TEST RESULTS (MODE 1).....	49
4.3.8 TEST RESULTS (MODE 2).....	51
4.4 CONDUCTED OUTPUT POWER MEASUREMENT.....	52
4.4.1 LIMITS OF CONDUCTED OUTPUT POWER MEASUREMENT.....	52
4.4.2 TEST INSTRUMENTS.....	52
4.4.3 TEST PROCEDURES.....	52
4.4.4 DEVIATION FROM TEST STANDARD.....	53
4.4.5 TEST SETUP.....	53
4.4.6 EUT OPERATING CONDITIONS.....	53
4.4.7 TEST RESULTS (MODE 1).....	54
4.4.8 TEST RESULTS (MODE 2).....	55
4.5 POWER SPECTRAL DENSITY MEASUREMENT.....	56
4.5.1 LIMITS OF POWER SPECTRAL DENSITY MEASUREMENT.....	56
4.5.2 TEST INSTRUMENTS.....	56



A D T

4.5.3	TEST PROCEDURE.....	56
4.5.4	DEVIATION FROM TEST STANDARD.....	56
4.5.5	TEST SETUP.....	57
4.5.6	EUT OPERATING CONDITION.....	57
4.5.7	TEST RESULTS (MODE 1).....	58
4.5.8	TEST RESULTS (MODE 2).....	61
4.6	CONDUCTED OUT-BAND EMISSION MEASUREMENT.....	63
4.6.1	LIMITS OF CONDUCTED OUT-BAND EMISSION MEASUREMENT.....	63
4.6.2	TEST INSTRUMENTS.....	63
4.6.3	TEST PROCEDURE.....	63
4.6.4	DEVIATION FROM TEST STANDARD.....	64
4.6.5	TEST SETUP.....	64
4.6.6	EUT OPERATING CONDITION.....	64
4.6.7	TEST RESULTS (MODE 1).....	64
4.6.8	TEST RESULTS (MODE 2).....	77
5.	PHOTOGRAPHS OF THE TEST CONFIGURATION.....	84
6.	INFORMATION ON THE TESTING LABORATORIES.....	85
7.	APPENDIX A - MODIFICATIONS RECORDERS FOR ENGINEERING CHANGES TO THE EUT BY THE LAB.....	86



A D T

RELEASE CONTROL RECORD

ISSUE NO.	REASON FOR CHANGE	DATE ISSUED
RF141029E01	Original release	Dec. 23, 2014



A D T

1. CERTIFICATION

PRODUCT: Wireless eMTA
BRAND NAME: Ubee
MODEL NO.: DVW32G
TEST SAMPLE: ENGINEERING SAMPLE
APPLICANT: Ubee Interactive Corp.
TESTED: Nov. 25 to Dec. 08, 2014
STANDARDS: **FCC Part 15, Subpart C (Section 15.247)**
ANSI C63.10-2009

The above equipment (Model: DVW32G) has been tested by **Bureau Veritas Consumer Products Services (H.K.) Ltd., Taoyuan Branch**, and found compliance with the requirement of the above standards. The test record, data evaluation & Equipment Under Test (EUT) configurations represented herein are true and accurate accounts of the measurements of the sample's EMC characteristics under the conditions specified in this report.

Prepared by :  , **Date:** Dec. 23, 2014
(Lori Chung, Specialist)

Approved by :  , **Date:** Dec. 23, 2014
(May Chen, Manager)



A D T

2. SUMMARY OF TEST RESULTS

The EUT has been tested according to the following specifications:

APPLIED STANDARD: FCC PART 15, SUBPART C (SECTION 15.247)			
STANDARD SECTION	TEST TYPE	RESULT	REMARK
15.207	AC Power Conducted Emission	PASS	Meet the requirement of limit. Minimum passing margin is -20.78dB at 0.18516MHz
15.205 15.209 15.247(d)	Radiated Emissions & Band Edge Measurement	PASS	Meet the requirement of limit. Minimum passing margin is -0.1dB at 2491.20MHz
15.247(d)	Antenna Port Emission	PASS	Meet the requirement of limit.
15.247(a)(2)	6dB bandwidth	PASS	Meet the requirement of limit.
15.247(b)	Conducted Output power	PASS	Meet the requirement of limit.
15.247(e)	Power Spectral Density	PASS	Meet the requirement of limit.
15.203	Antenna Requirement	PASS	Antenna connector is MHF not a standard connector.

NOTE: The EUT was operating in 2.400 ~ 2.4835GHz, 5.15~5.25GHz and 5.725~5.850GHz frequencies band. This report was recorded the RF parameters including 2.400 ~ 2.4835GHz. For the 5.15~5.25GHz and 5.725~5.850GHz RF parameters was recorded in another test report.



A D T

2.1 MEASUREMENT UNCERTAINTY

Where relevant, the following measurement uncertainty levels have been estimated for tests performed on the EUT as specified in CISPR 16-4-2:

This uncertainty represents an expanded uncertainty expressed at approximately the 95% confidence level using a coverage factor of $k=2$.

Measurement	Value
Conducted emissions	2.86 dB
Radiated emissions (30MHz-1GHz)	5.37 dB
Radiated emissions (1GHz -6GHz)	3.72 dB
Radiated emissions (6GHz -18GHz)	4.00 dB
Radiated emissions (18GHz -40GHz)	4.11 dB



3. GENERAL INFORMATION

3.1 GENERAL DESCRIPTION OF EUT

PRODUCT	Wireless eMTA
MODEL NO.	DVW32G
POWER SUPPLY	AC Input: 100-120Vac
MODULATION TYPE	CCK, DQPSK, DBPSK for DSSS 64QAM, 16QAM, QPSK, BPSK for OFDM 256QAM for OFDM in 11ac mode and VHT (20/40) mode in 2.4GHz
MODULATION TECHNOLOGY	DSSS, OFDM
TRANSFER RATE	802.11b: up to 11Mbps 802.11a / g: up to 54Mbps 802.11n: up to 450Mbps 802.11ac: up to 1300Mbps
OPERATING FREQUENCY	For 15.407 5.18 ~ 5.24GHz, 5.745 ~ 5.825GHz
	For 15.247 2.412 ~ 2.462GHz
NUMBER OF CHANNEL	For 15.407 9 for 802.11a, 802.11n (HT20), 802.11ac (VHT20) 4 for 802.11n (HT40), 802.11ac (VHT40) 2 for 802.11ac (VHT80)
	For 15.247 11 for 802.11b, 802.11g, 802.11n (HT20). VHT20 7 for 802.11n (HT40), VHT40
MAXIMUM OUTPUT POWER	For 15.407 CDD Mode: 802.11a: 251.281mW 802.11ac (VHT20): 234.222mW 802.11ac (VHT40): 272.803mW 802.11ac (VHT80): 143.433mW Beamforming Mode: 802.11ac (VHT20): 225.239mW 802.11ac (VHT40): 208.671mW 802.11ac (VHT80): 112.167mW For 15.247 CDD Mode: 802.11b: 437.359mW 802.11g: 679.335mW VHT20: 584.672mW VHT40: 188.996mW Beamforming Mode: VHT20: 371.197mW VHT40: 188.996mW



A D T

ANTENNA TYPE	Please see NOTE
DATA CABLE	RJ11 cable (Unshielded, 1.5m) RJ45 cable (Unshielded, 1.5m)
I/O PORTS	Refer to user's manual
ASSOCIATED DEVICES	Battery (optional)

NOTE:

1. The antennas provided to the EUT, please refer to the following table:

Antenna set 1						
Antenna No.	Brand	Model	Gain (dBi) Including cable loss	Antenna Type	Connector Type	Frequency range (GHz to GHz)
1	WHA YU	NA	4.6	Dipole (PCB)	MHF	2.4~2.4835
			4.4			5.15~5.25
			6.3			5.725~5.850
2	WHA YU	NA	6	Dipole (PCB)	MHF	2.4~2.4835
			4.6			5.15~5.25
			5.8			5.725~5.850
3	WHA YU	NA	5.3	Dipole (PCB)	MHF	2.4~2.4835
			3.8			5.15~5.25
			4.2			5.725~5.850
Antenna set 2						
Antenna No.	Brand	Model	Gain (dBi) Including cable loss	Antenna Type	Connector Type	Frequency range (GHz to GHz)
1 (Black)	TONGDA	NA	4.453	Dipole (PCB)	MHF	2.4~2.4835
			4.289			5.15~5.25
			6.158			5.725~5.850
2 (Gray)	TONGDA	NA	5.989	Dipole (PCB)	MHF	2.4~2.4835
			4.442			5.15~5.25
			5.633			5.725~5.850
3 (White)	TONGDA	NA	5.120	Dipole (PCB)	MHF	2.4~2.4835
			3.508			5.15~5.25
			4.058			5.725~5.850

From the above antenna sets, antenna set 1 was selected as representative antenna for the 802.11b/g test and its data was recorded in this report.

2. 2.4GHz & 5GHz technology can transmit at same time.

3. The EUT must be supplied with an internal power supply as below table:

Brand	Model No.	Spec.
CHICONY POWER TECHNOLOGY CO LTD	N12-035N1A	AC Input: 100-120Vac, 0.9A max, 60Hz DC Output: 12Vdc, 2.92A, class II

4. The associated devices(optional) of EUT information are as below:

Battery (optional)		
Brand	Model No.	Rated
SIMPLO TECHNOLOGY CO LTD	SMPCM10	7.4Vdc, 2550mAh



A D T

5. The EUT incorporates a MIMO function.

2.4GHz			
MODULATION MODE	DATA RATE (MCS)	TX & RX CONFIGURATION	
802.11b	1 ~ 11Mbps	3TX	3RX
802.11g	6 ~ 54Mbps	3TX	3RX
802.11n (HT20)	MCS 0~7	3TX	3RX
	MCS 8~15	3TX	3RX
	MCS 16~23	3TX	3RX
802.11n (HT40)	MCS 0~7	3TX	3RX
	MCS 8~15	3TX	3RX
	MCS 16~23	3TX	3RX
VHT20	MCS 0~8, Nss=1	3TX	3RX
	MCS 0~8, Nss=2	3TX	3RX
	MCS 0~9, Nss=3	3TX	3RX
VHT40	MCS 0~9, Nss=1	3TX	3RX
	MCS 0~9, Nss=2	3TX	3RX
	MCS 0~9, Nss=3	3TX	3RX
5GHz			
MODULATION MODE	DATA RATE (MCS)	TX & RX CONFIGURATION	
802.11a	6 ~ 54Mbps	3TX	3RX
802.11n (HT20)	MCS 0~7	3TX	3RX
	MCS 8~15	3TX	3RX
	MCS 16~23	3TX	3RX
802.11n (HT40)	MCS 0~7	3TX	3RX
	MCS 8~15	3TX	3RX
	MCS 16~23	3TX	3RX
802.11ac (VHT20)	MCS 0~8, Nss=1	3TX	3RX
	MCS 0~8, Nss=2	3TX	3RX
	MCS 0~9, Nss=3	3TX	3RX
802.11ac (VHT40)	MCS 0~9, Nss=1	3TX	3RX
	MCS 0~9, Nss=2	3TX	3RX
	MCS 0~9, Nss=3	3TX	3RX
802.11ac (VHT80)	MCS 0~9, Nss=1	3TX	3RX
	MCS 0~9, Nss=2	3TX	3RX
	MCS 0~9, Nss=3	3TX	3RX

6. The above EUT information was declared by manufacturer and for more detailed features description, please refer to the manufacturer's specifications or user's manual.

3.2 DESCRIPTION OF TEST MODES

11 channels are provided for 802.11b, 802.11g, 802.11n (HT20), VHT20:

CHANNEL	FREQUENCY	CHANNEL	FREQUENCY
1	2412MHz	7	2442MHz
2	2417MHz	8	2447MHz
3	2422MHz	9	2452MHz
4	2427MHz	10	2457MHz
5	2432MHz	11	2462MHz
6	2437MHz		

7 channels are provided for 802.11n (HT40), VHT40:

CHANNEL	FREQUENCY	CHANNEL	FREQUENCY
3	2422MHz	7	2442MHz
4	2427MHz	8	2447MHz
5	2432MHz	9	2452MHz
6	2437MHz		



3.2.1 TEST MODE APPLICABILITY AND TESTED CHANNEL DETAIL

EUT CONFIGURE MODE	APPLICABLE TO					DESCRIPTION
	PLC	RE < 1G	RE ≥ 1G	APCM	OB	
-	√	√	√	√	√	-

Where **PLC**: Power Line Conducted Emission **RE < 1G**: Radiated Emission below 1GHz
RE ≥ 1G: Radiated Emission above 1GHz **APCM**: Antenna Port Conducted Measurement
OB: Conducted Out-Band Emission Measurement

POWER LINE CONDUCTED EMISSION TEST:

- Pre-Scan has been conducted to determine the worst-case mode from all possible combinations between available modulations, data rates and antenna ports (if EUT with antenna diversity architecture).
- Following channel(s) was (were) selected for the final test as listed below.

CDD MODE					
MODE	AVAILABLE CHANNEL	TESTED CHANNEL	MODULATION TECHNOLOGY	MODULATION TYPE	DATA RATE (Mbps)
802.11g	1 to 11	6	OFDM	BPSK	6

RADIATED EMISSION TEST (BELOW 1 GHz):

- Pre-Scan has been conducted to determine the worst-case mode from all possible combinations between available modulations, data rates and antenna ports (if EUT with antenna diversity architecture).
- Following channel(s) was (were) selected for the final test as listed below.

CDD MODE					
MODE	AVAILABLE CHANNEL	TESTED CHANNEL	MODULATION TECHNOLOGY	MODULATION TYPE	DATA RATE (Mbps)
802.11g	1 to 11	6	OFDM	BPSK	6



RADIATED EMISSION TEST (ABOVE 1 GHz):

- Pre-Scan has been conducted to determine the worst-case mode from all possible combinations between available modulations, data rates and antenna ports (if EUT with antenna diversity architecture).
- Following channel(s) was (were) selected for the final test as listed below.

CDD MODE					
MODE	AVAILABLE CHANNEL	TESTED CHANNEL	MODULATION TECHNOLOGY	MODULATION TYPE	DATA RATE (Mbps)
802.11b	1 to 11	1, 6, 11	DSSS	DBPSK	1
802.11g	1 to 11	1, 6, 11	OFDM	BPSK	6
VHT20	1 to 11	1, 6, 11	OFDM	BPSK	6.5
VHT40	3 to 9	3, 6, 9	OFDM	BPSK	13.5

Beamforming MODE					
MODE	AVAILABLE CHANNEL	TESTED CHANNEL	MODULATION TECHNOLOGY	MODULATION TYPE	DATA RATE (Mbps)
VHT20	1 to 11	1, 6, 11	OFDM	BPSK	6.5
VHT40	3 to 9	3, 6, 9	OFDM	BPSK	13.5

ANTENNA PORT CONDUCTED MEASUREMENT:

- Pre-Scan has been conducted to determine the worst-case mode from all possible combinations between available modulations, data rates and antenna ports (if EUT with antenna diversity architecture).
- Following channel(s) was (were) selected for the final test as listed below.

CDD MODE					
MODE	AVAILABLE CHANNEL	TESTED CHANNEL	MODULATION TECHNOLOGY	MODULATION TYPE	DATA RATE (Mbps)
802.11b	1 to 11	1, 6, 11	DSSS	DBPSK	1
802.11g	1 to 11	1, 6, 11	OFDM	BPSK	6
VHT20	1 to 11	1, 6, 11	OFDM	BPSK	6.5
VHT40	3 to 9	3, 6, 9	OFDM	BPSK	13.5

Beamforming MODE					
MODE	AVAILABLE CHANNEL	TESTED CHANNEL	MODULATION TECHNOLOGY	MODULATION TYPE	DATA RATE (Mbps)
VHT20	1 to 11	1, 6, 11	OFDM	BPSK	6.5
VHT40	3 to 9	3, 6, 9	OFDM	BPSK	13.5



CONDUCTED OUT-BAND EMISSION MEASUREMENT:

- Pre-Scan has been conducted to determine the worst-case mode from all possible combinations between available modulations, data rates and antenna ports (if EUT with antenna diversity architecture).
- Following channel(s) was (were) selected for the final test as listed below.

CDD MODE					
MODE	AVAILABLE CHANNEL	TESTED CHANNEL	MODULATION TECHNOLOGY	MODULATION TYPE	DATA RATE (Mbps)
802.11b	1 to 11	1, 6, 11	DSSS	DBPSK	1
802.11g	1 to 11	1, 6, 11	OFDM	BPSK	6
VHT20	1 to 11	1, 6, 11	OFDM	BPSK	6.5
VHT40	3 to 9	3, 6, 9	OFDM	BPSK	13.5
Beamforming MODE					
MODE	AVAILABLE CHANNEL	TESTED CHANNEL	MODULATION TECHNOLOGY	MODULATION TYPE	DATA RATE (Mbps)
VHT20	1 to 11	1, 6, 11	OFDM	BPSK	6.5
VHT40	3 to 9	3, 6, 9	OFDM	BPSK	13.5

TEST CONDITION:

APPLICABLE TO	ENVIRONMENTAL CONDITIONS	INPUT POWER	TESTED BY
PLC	25deg. C, 71%RH	120Vac, 60Hz	Wythe Lin
RE<1G	25deg. C, 73%RH	120Vac, 60Hz	Andy Ho
RE≥1G	20deg. C, 67%RH	120Vac, 60Hz	Gary Cheng
APCM	25deg. C, 60%RH	120Vac, 60Hz	Anderson Chen
OB	25deg. C, 60%RH	120Vac, 60Hz	James Chan



A D T

3.3 GENERAL DESCRIPTION OF APPLIED STANDARDS

The EUT is a RF product. According to the specifications of the manufacturer, it must comply with the requirements of the following standards:

FCC Part 15, Subpart C (15.247)

558074 D01 DTS Meas Guidance v03r02

662911 D01 Multiple Transmitter Output v02r01

ANSI C63.10-2009

All test items have been performed and recorded as per the above standards.

Note: The EUT has been verified to comply with the requirements of FCC Part 15, Subpart B, Class B (DoC). The test report has been issued separately.

3.4 DUTY CYCLE OF TEST SIGNAL

If duty cycle of test signal is $\geq 98\%$, duty factor is not required.

If duty cycle of test signal is $< 98\%$, duty factor shall be considered.

802.11b: Duty cycle = 24.833 ms/24.857 ms = 0.999

802.11g: Duty cycle = 2.062 ms/2.082 ms = 0.99

VHT20: Duty cycle = 1.918 ms/1.939 ms = 0.989

VHT40: Duty cycle = 0.941 ms/0.961 ms = 0.979, Duty factor = $10 * \log(1/0.979) = 0.09$

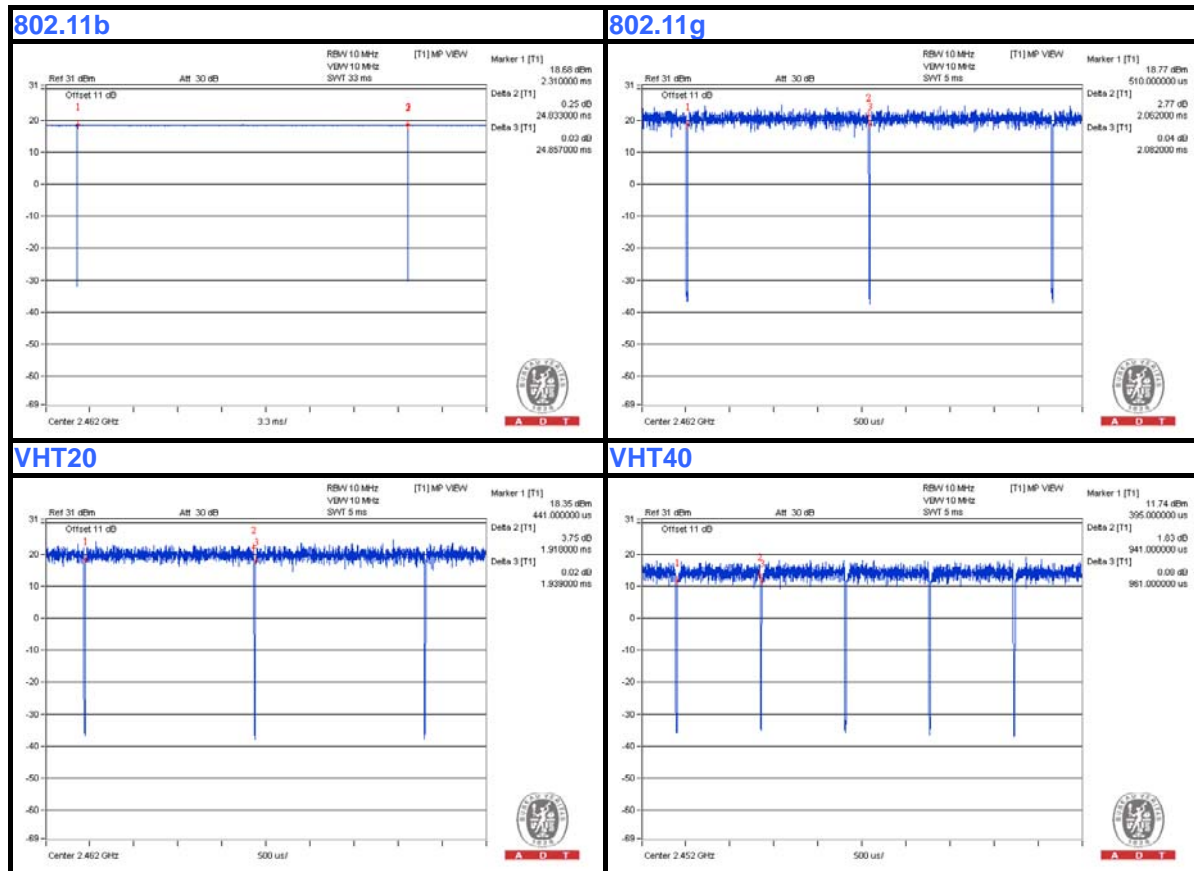



3.5 DESCRIPTION OF SUPPORT UNITS

The EUT has been tested as an independent unit together with other necessary accessories or support units. The following support units or accessories were used to form a representative test configuration during the tests.

No.	Product	Brand	Model No.	Serial No.	FCC ID	Remark
A	TELEPHONE	WONDER	WD-303	7C17KA04011	NA	Provided by Lab
B	TELEPHONE	WONDER	WD-303	7C17KA05211	NA	Provided by Lab
C	iPod shuffle	Apple	MD778TA/A	CC4JMH7LF4T1	NA	Provided by Lab
D	HUB	ZyXEL	ES-116P	S060H02000215	FCC DoC	Provided by Lab
E	NOTEBOOK COMPUTER	DELL	E5440	6FC7F12	FCC DoC	Provided by Lab
F	Termination system	CASA SYSTEM	CASA C2200	NA	NA	Supplied by client
G	Ethernet/Coax Bridge	Broadcom	BCM97428	NA	NA	Supplied by client
H	NOTEBOOK COMPUTER	DELL	E5430	4N1SKV1	FCC DoC	Provided by Lab

NOTE:

1. All power cords of the above support units are non-shielded (1.8 m).

No.	Cable	Qty.	Length (m)	Shielded (Yes/ No)	Cores (Number)	Remark
1	RJ11	1	1.5	No	0	Supplied by client
2	RJ11	1	1.5	No	0	Supplied by client
3	RJ45	3	10	No	0	Provided by Lab
4	RJ45	1	10	No	0	Provided by Lab
5	USB	1	0.1	No	0	Provided by Lab
6	Coaxial	1	10	No	0	Provided by Lab
7	AC	1	1.5	No	0	Supplied by client
8	Coaxial	1	1	Yes	0	Supplied by client
9	RJ45	1	1	No	0	Supplied by client

3.6 CONFIGURATION OF SYSTEM UNDER TEST

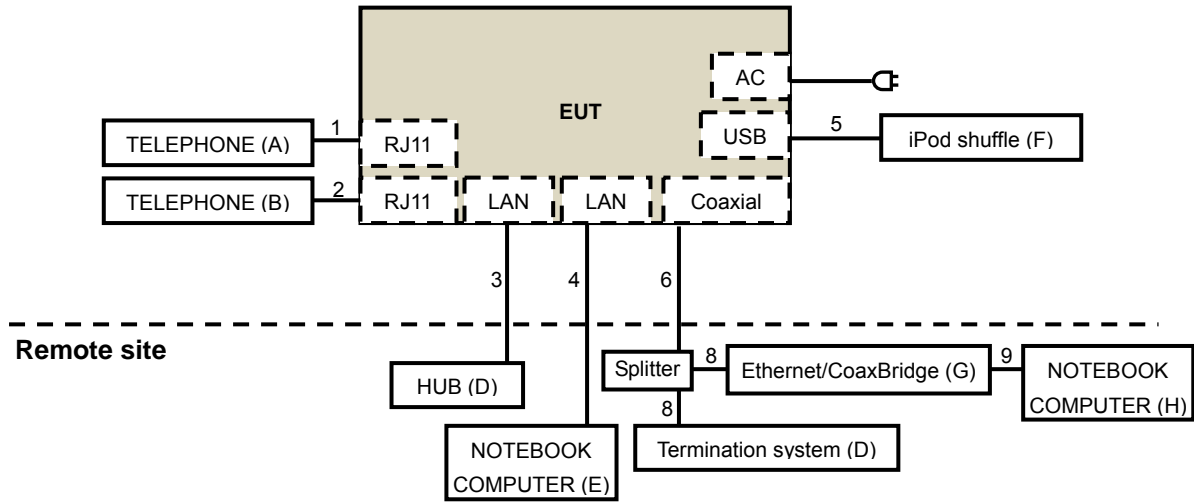



A D T

4. TEST TYPES AND RESULTS

4.1 CONDUCTED EMISSION MEASUREMENT

4.1.1 LIMITS OF CONDUCTED EMISSION MEASUREMENT

FREQUENCY OF EMISSION (MHz)	CONDUCTED LIMIT (dB μ V)	
	Quasi-peak	Average
0.15-0.5	66 to 56	56 to 46
0.5-5	56	46
5-30	60	50

- NOTE:**
1. The lower limit shall apply at the transition frequencies.
 2. The limit decreases in line with the logarithm of the frequency in the range of 0.15 to 0.50 MHz.

4.1.2 TEST INSTRUMENTS

DESCRIPTION & MANUFACTURER	MODEL NO.	SERIAL NO.	CALIBRATED DATE	CALIBRATED UNTIL
Test Receiver ROHDE & SCHWARZ	ESCS 30	100375	Apr. 29, 2014	Apr. 28, 2015
Line-Impedance Stabilization Network (for EUT) SCHWARZBECK	NSLK-8127	8127-522	Sep. 15, 2014	Sep. 14, 2015
Line-Impedance Stabilization Network (for Peripheral) ROHDE & SCHWARZ	ENV216	100071	Nov. 10, 2014	Nov. 09, 2015
RF Cable (JYEBAO)	5DFB	COCCAB-001	Mar. 10, 2014	Mar. 09, 2015
50 ohms Terminator	N/A	EMC-03	Sep. 22, 2014	Sep. 21, 2015
50 ohms Terminator	N/A	EMC-02	Sep. 30, 2014	Sep. 29, 2015
Software ADT	BV ADT_Cond_V7.3.7 .3	NA	NA	NA

Note:

1. The calibration interval of the above test instruments is 12 months and the calibrations are traceable to NML/ROC and NIST/USA.
2. The test was performed in Shielded Room No. C.
3. The VCCI Con C Registration No. is C-3611.
4. Tested Date: Nov. 27, 2014

4.1.3 TEST PROCEDURES

- a. The EUT was placed 0.4 meters from the conducting wall of the shielded room with EUT being connected to the power mains through a line impedance stabilization network (LISN). Other support units were connected to the power mains through another LISN.
- b. The two LISNs provide 50 ohm/ 50uH of coupling impedance for the measuring instrument.
- c. Both lines of the power mains connected to the EUT were checked for maximum conducted interference.
- d. The frequency range from 150kHz to 30MHz was searched. Emission levels under (Limit - 20dB) were not recorded.

NOTE:

1. The resolution bandwidth of test receiver is 9kHz for Quasi-peak detection (QP) & Average detection (AV).

4.1.4 DEVIATION FROM TEST STANDARD

No deviation

4.1.5 TEST SETUP

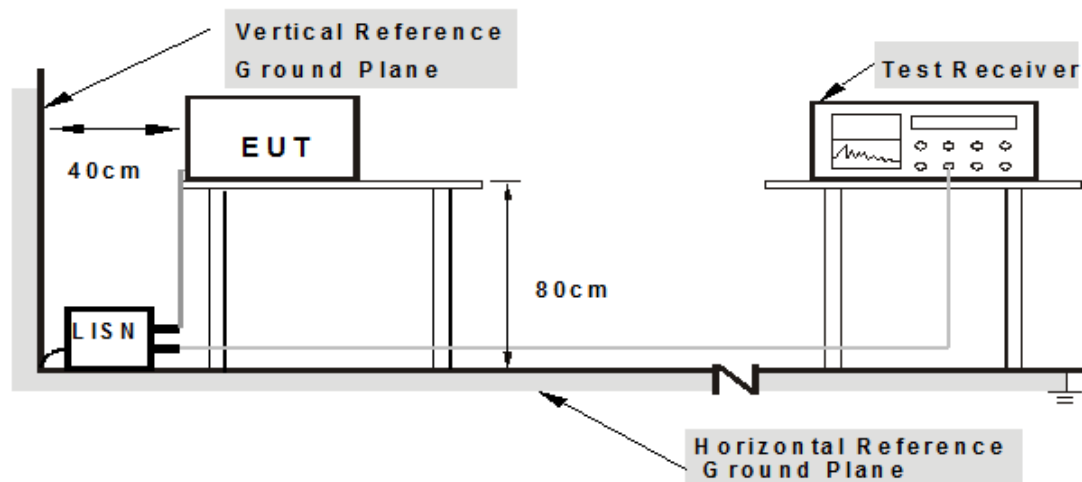

Note: 1. Support units were connected to second LISN.

For the actual test configuration, please refer to the related item – Photographs of the Test Configuration.



A D T

4.1.6 EUT OPERATING CONDITIONS

1. Connect the EUT with the support unit E (Notebook Computer) which is placed on remote site.
2. Controlling software (MTool_2.0.1.1.msi) has been activated to set the EUT on specific status.

4.1.7 TEST RESULTS

PHASE	Line (L)	DETECTOR FUNCTION	Quasi-Peak (QP) / Average (AV)
-------	----------	-------------------	--------------------------------

No	Freq. [MHz]	Corr. Factor (dB)	Reading Value [dB (uV)]		Emission Level [dB (uV)]		Limit [dB (uV)]		Margin (dB)	
			Q.P.	AV.	Q.P.	AV.	Q.P.	AV.	Q.P.	AV.
			1	0.18516	0.07	43.40	28.35	43.47	28.42	64.25
2	0.34531	0.08	33.43	17.68	33.51	17.76	59.07	49.07	-25.56	-31.31
3	0.62266	0.10	32.10	17.73	32.20	17.83	56.00	46.00	-23.80	-28.17
4	3.02734	0.22	25.32	15.31	25.54	15.53	56.00	46.00	-30.46	-30.47
5	9.25781	0.43	23.95	15.63	24.38	16.06	60.00	50.00	-35.62	-33.94
6	20.46094	0.71	31.18	23.43	31.89	24.14	60.00	50.00	-28.11	-25.86

REMARKS:

1. Q.P. and AV. are abbreviations of quasi-peak and average individually.
2. The emission levels of other frequencies were very low against the limit.
3. Margin value = Emission Level – Limit value
4. Correction Factor = Insertion loss + Cable loss
5. Emission Level = Correction Factor + Reading Value

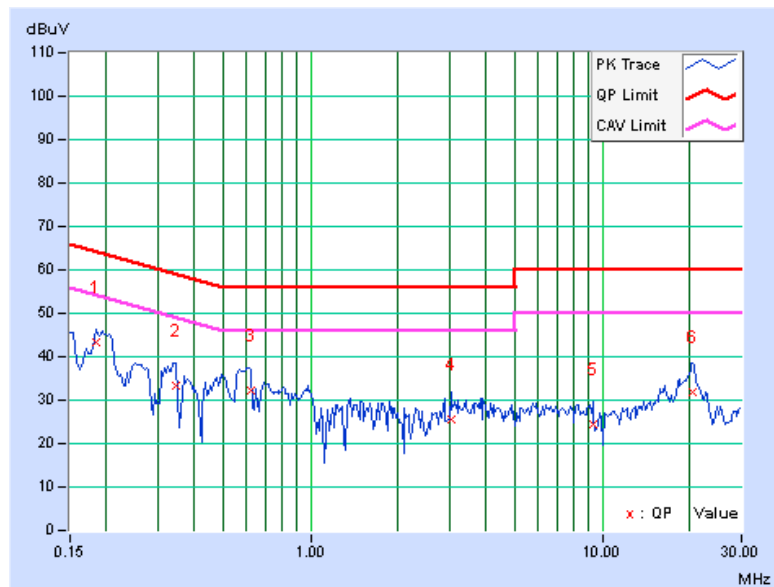



A D T

PHASE	Neutral (N)	DETECTOR FUNCTION	Quasi-Peak (QP) / Average (AV)
--------------	-------------	--------------------------	--------------------------------

No	Freq. [MHz]	Corr. Factor (dB)	Reading Value [dB (uV)]		Emission Level [dB (uV)]		Limit [dB (uV)]		Margin (dB)	
			Q.P.	AV.	Q.P.	AV.	Q.P.	AV.	Q.P.	AV.
1	0.18516	0.06	42.72	27.49	42.78	27.55	64.25	54.25	-21.47	-26.70
2	0.50156	0.10	32.49	19.56	32.59	19.66	56.00	46.00	-23.41	-26.34
3	0.99375	0.13	26.25	11.80	26.38	11.93	56.00	46.00	-29.62	-34.07
4	3.40234	0.24	26.49	15.54	26.73	15.78	56.00	46.00	-29.27	-30.22
5	8.41797	0.41	27.46	21.95	27.87	22.36	60.00	50.00	-32.13	-27.64
6	20.54688	0.75	29.74	22.27	30.49	23.02	60.00	50.00	-29.51	-26.98

REMARKS:

1. Q.P. and AV. are abbreviations of quasi-peak and average individually.
2. The emission levels of other frequencies were very low against the limit.
3. Margin value = Emission Level – Limit value
4. Correction Factor = Insertion loss + Cable loss
5. Emission Level = Correction Factor + Reading Value

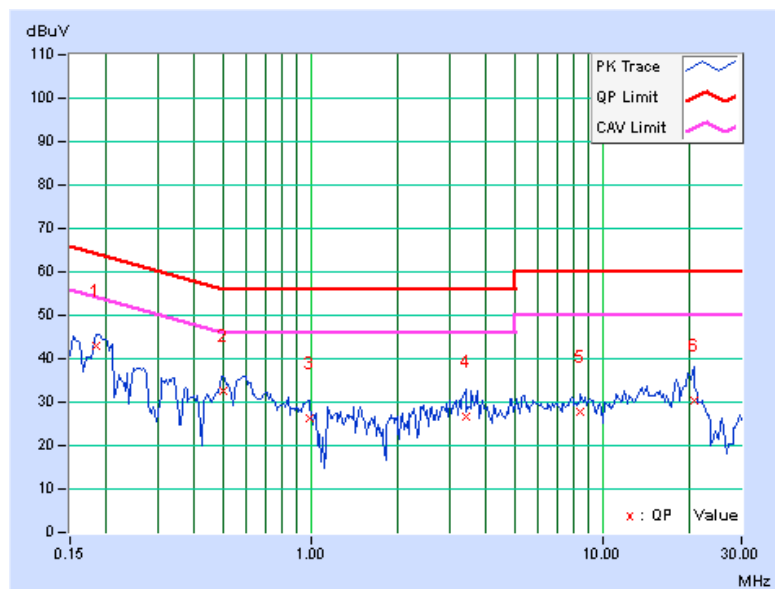



A D T

4.2 RADIATED EMISSION AND BANDEDGE MEASUREMENT

4.2.1 LIMITS OF RADIATED EMISSION AND BANDEDGE MEASUREMENT

Radiated emissions which fall in the restricted bands must comply with the radiated emission limits specified as below table. Other emissions shall be at least 30dB below the highest level of the desired power:

Frequencies (MHz)	Field strength (microvolts/meter)	Measurement distance (meters)
0.009-0.490	2400/F(kHz)	300
0.490-1.705	24000/F(kHz)	30
1.705-30.0	30	30
30-88	100	3
88-216	150	3
216-960	200	3
Above 960	500	3

NOTE:

1. The lower limit shall apply at the transition frequencies.
2. Emission level (dBuV/m) = 20 log Emission level (uV/m).
3. For frequencies above 1000MHz, the field strength limits are based on average detector, however, the peak field strength of any emission shall not exceed the maximum permitted average limits, specified above by more than 20dB under any condition of modulation.



A D T

4.2.2 TEST INSTRUMENTS

For Below 1GHz test:

DESCRIPTION & MANUFACTURER	MODEL NO.	SERIAL NO.	CALIBRATED DATE	CALIBRATED UNTIL
MXE EMI Receiver Agilent	N9038A	MY51210105	July 21, 2014	July 20, 2015
Pre-Amplifier Mini-Circuits	ZFL-1000VH2 B	AMP-ZFL-03	Nov. 12, 2014	Nov. 11, 2015
Trilog Broadband Antenna SCHWARZBECK	VULB 9168	9168-360	Feb. 26, 2014	Feb. 25, 2015
RF Cable	NA	CHGCAB_001	Oct. 04, 2014	Oct. 03, 2015
Horn_Antenna AISL	AIH.8018	0000320091110	Aug. 27, 2014	Aug. 26, 2015
Pre-Amplifier Agilent	8449B	3008A02578	June 24, 2014	June 23, 2015
RF Cable	NA	131205 131214 SNMY23684/4	Jan. 17, 2014	Jan. 16, 2015
Spectrum Analyzer R&S	FSV40	100964	July 05, 2014	July 04, 2015
Pre-Amplifier EMCI	EMC184045	980143	Jan. 17, 2014	Jan. 16, 2015
Horn_Antenna SCHWARZBECK	BBHA 9170	9170-424	Aug. 26, 2014	Aug. 25, 2015
RF Cable	NA	RF104-121 RF104-204	Dec. 12, 2013	Dec. 11, 2014
Antenna Tower & Turn Table CT	NA	NA	NA	NA

Note:

1. The calibration interval of the above test instruments is 12 months and the calibrations are traceable to NML/ROC and NIST/USA.
2. The horn antenna, preamplifier (model: 8449B) are used only for the measurement of emission frequency above 1GHz if tested.
- 3 The test was performed in 966 Chamber No. G.
4. The FCC Site Registration No. is 966073.
- 5 The VCCI Site Registration No. is G-137.
- 6 The CANADA Site Registration No. is IC 7450H-2.
- 7 Tested Date: Nov. 25, 2014



A D T

For Above 1GHz test:

DESCRIPTION & MANUFACTURER	MODEL NO.	SERIAL NO.	CALIBRATED DATE	CALIBRATED UNTIL
MXE EMI Receiver Agilent	N9038A	MY50010156	Aug. 11, 2014	Aug. 10, 2015
Pre-Amplifier Mini-Circuits	ZFL-1000VH2 B	AMP-ZFL-04	Nov. 12, 2014	Nov. 11, 2015
Trilog Broadband Antenna SCHWARZBECK	VULB 9168	9168-361	Feb. 27, 2014	Feb. 26, 2015
RF Cable	NA	CHHCAB_001	Oct. 05, 2014	Oct. 04, 2015
Horn_Antenna AISI	AIH.8018	0000220091110	Aug. 26, 2014	Aug. 25, 2015
Pre-Amplifier Agilent	8449B	300801923	Oct. 28, 2014	Oct. 27, 2015
RF Cable	NA	131206 131215 SNMY23685/4	Jan. 17, 2014	Jan. 16, 2015
Spectrum Analyzer R&S	FSV40	100964	July 05, 2014	July 04, 2015
Pre-Amplifier EMCI	EMC184045	980143	Jan. 17, 2014	Jan. 16, 2015
Horn_Antenna SCHWARZBECK	BBHA 9170	9170-424	Aug. 26, 2014	Aug. 25, 2015
RF Cable	NA	RF104-121 RF104-204	Dec. 12, 2013	Dec. 11, 2014
Software	ADT_Radiated _V8.7.07	NA	NA	NA
Antenna Tower & Turn Table CT	NA	NA	NA	NA

Note:

1. The calibration interval of the above test instruments is 12 months and the calibrations are traceable to NML/ROC and NIST/USA.
2. The horn antenna, preamplifier (model: 8449B) are used only for the measurement of emission frequency above 1GHz if tested.
- 3 The test was performed in 966 Chamber No. H.
4. The FCC Site Registration No. is 797305.
- 5 The CANADA Site Registration No. is IC 7450H-3.
- 6 Tested Date: Dec. 01, 2014

4.2.3 TEST PROCEDURES

- a. The EUT was placed on the top of a rotating table 0.8 meters above the ground at 3 meter chamber room for test. The table was rotated 360 degrees to determine the position of the highest radiation.
- b. The EUT was set 3 meters away from the interference-receiving antenna, which was mounted on the top of a variable-height antenna tower.
- c. The height of antenna is varied from one meter to four meters above the ground to determine the maximum value of the field strength. Both horizontal and vertical polarizations of the antenna are set to make the measurement.
- d. For each suspected emission, the EUT was arranged to its worst case and then the antenna was tuned to heights from 1 meter to 4 meters and the rotatable table was turned from 0 degrees to 360 degrees to find the maximum reading.
- e. The test-receiver system was set to quasi-peak detect function and specified bandwidth with maximum hold mode when the test frequency is below 1 GHz.
- f. The test-receiver system was set to peak and average detect function and specified bandwidth with maximum hold mode when the test frequency is above 1 GHz. If the peak reading value also meets average limit, measurement with the average detector is unnecessary.

Note:

1. The resolution bandwidth and video bandwidth of test receiver/spectrum analyzer is 120kHz for Quasi-peak detection (QP) at frequency below 1GHz.
2. The resolution bandwidth of test receiver/spectrum analyzer is 1 MHz and the video bandwidth is 3 MHz for Peak detection (PK) at frequency above 1GHz.
3. The resolution bandwidth of test receiver/spectrum analyzer is 1MHz and the video bandwidth is 3MHz for RMS Average (Duty cycle < 98%) for Average detection (AV) at frequency above 1GHz, then the measurement results was added to a correction factor ($10 \log(1/\text{duty cycle})$).
4. The resolution bandwidth of test receiver/spectrum analyzer is 1MHz and the video bandwidth is 10Hz (Duty cycle $\geq 98\%$) for Average detection (AV) at frequency above 1GHz.
5. All modes of operation were investigated and the worst-case emissions are reported.

4.2.4 DEVIATION FROM TEST STANDARD

No deviation

4.2.5 TEST SETUP

<Frequency Range below 1GHz>

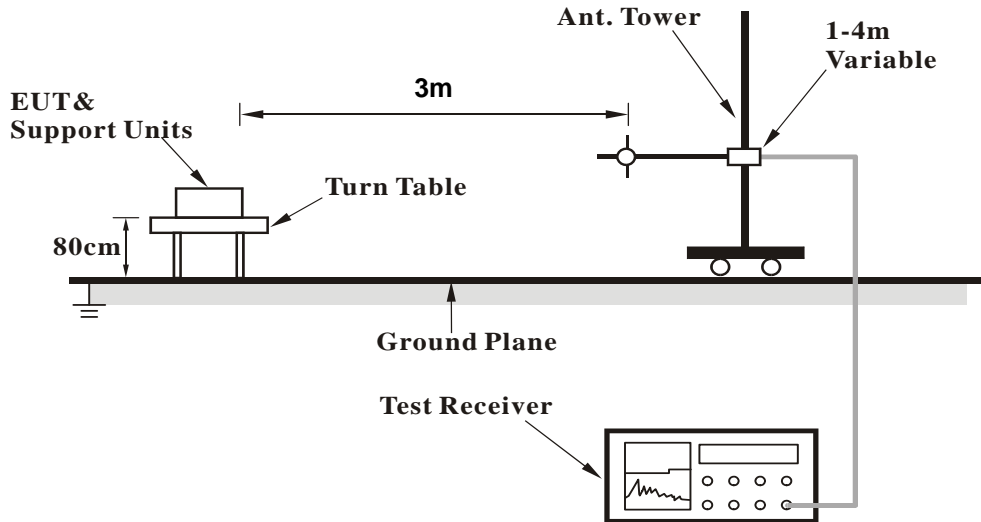

<Frequency Range above 1GHz>

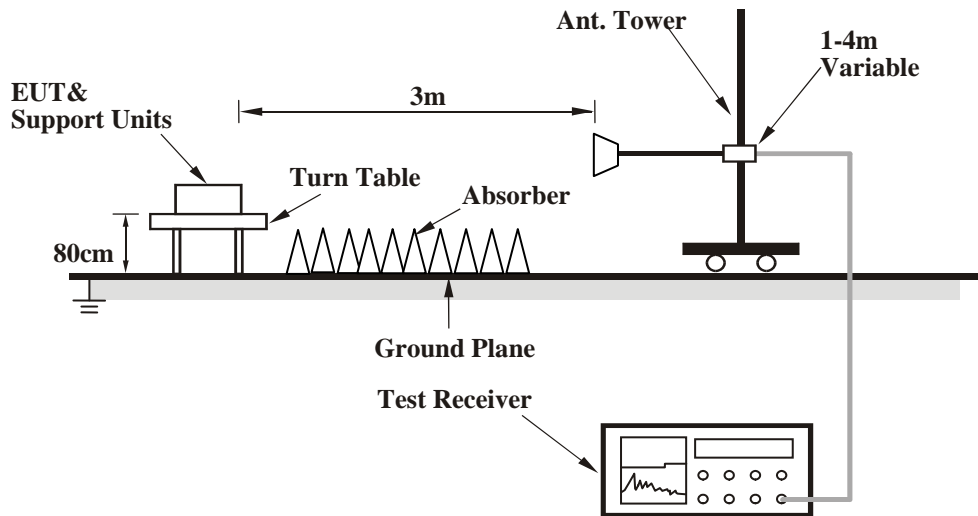

For the actual test configuration, please refer to the related item – Photographs of the Test Configuration.

4.2.6 EUT OPERATING CONDITIONS

Same as 4.1.6



A D T

4.2.7 TEST RESULTS (MODE 1)

BELOW 1GHz WORST-CASE DATA

802.11g

CHANNEL	TX Channel 6	DETECTOR FUNCTION	Quasi-Peak (QP)
FREQUENCY RANGE	Below 1GHz		

ANTENNA POLARITY & TEST DISTANCE: HORIZONTAL AT 3 M								
NO.	FREQ. (MHz)	EMISSION LEVEL (dBuV/m)	LIMIT (dBuV/m)	MARGIN (dB)	ANTENNA HEIGHT (m)	TABLE ANGLE (Degree)	RAW VALUE (dBuV)	CORRECTION FACTOR (dB/m)
1	159.98	33.3 QP	43.5	-10.3	1.50 H	267	46.03	-12.78
2	250.00	35.2 QP	46.0	-10.9	1.00 H	294	49.07	-13.92
3	375.03	38.1 QP	46.0	-7.9	2.00 H	71	47.90	-9.78
4	625.00	41.0 QP	46.0	-5.0	1.00 H	99	44.66	-3.68
5	749.98	42.2 QP	46.0	-3.8	1.00 H	326	43.45	-1.21
6	902.76	40.2 QP	46.0	-5.8	2.00 H	153	39.31	0.87

ANTENNA POLARITY & TEST DISTANCE: VERTICAL AT 3 M								
NO.	FREQ. (MHz)	EMISSION LEVEL (dBuV/m)	LIMIT (dBuV/m)	MARGIN (dB)	ANTENNA HEIGHT (m)	TABLE ANGLE (Degree)	RAW VALUE (dBuV)	CORRECTION FACTOR (dB/m)
1	35.51	32.4 QP	40.0	-7.6	1.00 V	210	46.43	-14.02
2	71.95	30.8 QP	40.0	-9.2	1.00 V	169	46.45	-15.64
3	200.04	32.5 QP	43.5	-11.1	1.00 V	127	48.38	-15.93
4	374.98	34.4 QP	46.0	-11.6	1.00 V	8	44.21	-9.78
5	749.98	37.0 QP	46.0	-9.0	1.00 V	17	38.23	-1.21
6	902.81	37.4 QP	46.0	-8.6	2.00 V	108	36.55	0.87

REMARKS:

1. Emission Level(dBuV/m) = Raw Value(dBuV) + Correction Factor(dB/m)
2. Correction Factor(dB/m) = Antenna Factor(dB/m) + Cable Factor(dB) – Pre-Amplifier Factor(dB)
3. The other emission levels were very low against the limit.
4. Margin value = Emission Level – Limit value



A D T

ABOVE 1GHz DATA

802.11b

CHANNEL	TX Channel 1	DETECTOR FUNCTION	Peak (PK)
FREQUENCY RANGE	1GHz ~ 25GHz		Average (AV)

ANTENNA POLARITY & TEST DISTANCE: HORIZONTAL AT 3 M								
NO.	FREQ. (MHz)	EMISSION LEVEL (dBuV/m)	LIMIT (dBuV/m)	MARGIN (dB)	ANTENNA HEIGHT (m)	TABLE ANGLE (Degree)	RAW VALUE (dBuV)	CORRECTION FACTOR (dB/m)
1	2373.80	51.3 PK	74.0	-22.7	1.54 H	342	57.20	-5.90
2	2373.80	41.1 AV	54.0	-12.9	1.54 H	342	47.00	-5.90
3	*2412.00	106.5 PK			1.67 H	359	112.30	-5.80
4	*2412.00	104.0 AV			1.67 H	359	109.80	-5.80
5	2487.40	52.6 PK	74.0	-21.4	1.43 H	298	58.09	-5.49
6	2487.40	45.8 AV	54.0	-8.2	1.43 H	298	51.29	-5.49
7	4824.00	47.2 PK	74.0	-26.8	1.04 H	134	43.78	3.42
8	4824.00	36.1 AV	54.0	-17.9	1.04 H	134	32.68	3.42

ANTENNA POLARITY & TEST DISTANCE: VERTICAL AT 3 M								
NO.	FREQ. (MHz)	EMISSION LEVEL (dBuV/m)	LIMIT (dBuV/m)	MARGIN (dB)	ANTENNA HEIGHT (m)	TABLE ANGLE (Degree)	RAW VALUE (dBuV)	CORRECTION FACTOR (dB/m)
1	2373.80	58.3 PK	74.0	-15.7	1.19 V	155	64.20	-5.90
2	2373.80	50.0 AV	54.0	-4.0	1.19 V	155	55.90	-5.90
3	*2412.00	118.4 PK			1.13 V	184	124.20	-5.80
4	*2412.00	115.8 AV			1.13 V	184	121.60	-5.80
5	2491.20	59.5 PK	74.0	-14.5	1.08 V	193	64.97	-5.47
6	2491.20	53.9 AV	54.0	-0.1	1.08 V	193	59.37	-5.47
7	4824.00	48.3 PK	74.0	-25.7	1.29 V	88	44.88	3.42
8	4824.00	36.3 AV	54.0	-17.7	1.29 V	88	32.88	3.42

REMARKS:

1. Emission Level(dBuV/m) = Raw Value(dBuV) + Correction Factor(dB/m)
2. Correction Factor(dB/m) = Antenna Factor(dB/m) + Cable Factor(dB) – Pre-Amplifier Factor(dB)
3. The other emission levels were very low against the limit.
4. Margin value = Emission Level – Limit value
5. " * ": Fundamental frequency.



A D T

CHANNEL	TX Channel 6	DETECTOR FUNCTION	Peak (PK)
FREQUENCY RANGE	1GHz ~ 25GHz		Average (AV)

ANTENNA POLARITY & TEST DISTANCE: HORIZONTAL AT 3 M

NO.	FREQ. (MHz)	EMISSION LEVEL (dBuV/m)	LIMIT (dBuV/m)	MARGIN (dB)	ANTENNA HEIGHT (m)	TABLE ANGLE (Degree)	RAW VALUE (dBuV)	CORRECTION FACTOR (dB/m)
1	2310.00	51.3 PK	74.0	-22.7	1.71 H	350	57.32	-6.02
2	2310.00	40.1 AV	54.0	-13.9	1.71 H	350	46.12	-6.02
3	2312.72	51.6 PK	74.0	-22.4	1.68 H	283	57.60	-6.00
4	2312.72	45.4 AV	54.0	-8.6	1.68 H	283	51.40	-6.00
5	*2437.00	109.3 PK			1.71 H	350	115.00	-5.70
6	*2437.00	106.9 AV			1.71 H	350	112.60	-5.70
7	2483.50	52.5 PK	74.0	-21.5	1.71 H	350	57.99	-5.49
8	2483.50	42.2 AV	54.0	-11.8	1.71 H	350	47.69	-5.49
9	#2515.20	52.4 PK	89.3	-36.9	1.70 H	345	57.78	-5.38
10	#2515.20	44.1 AV	86.9	-42.8	1.70 H	345	49.48	-5.38
11	4874.00	47.2 PK	74.0	-26.8	1.05 H	128	43.80	3.40
12	4874.00	35.8 AV	54.0	-18.2	1.05 H	128	32.40	3.40
13	7311.00	51.8 PK	74.0	-22.2	1.24 H	89	44.04	7.76
14	7311.00	38.8 AV	54.0	-15.2	1.24 H	89	31.04	7.76

ANTENNA POLARITY & TEST DISTANCE: VERTICAL AT 3 M

NO.	FREQ. (MHz)	EMISSION LEVEL (dBuV/m)	LIMIT (dBuV/m)	MARGIN (dB)	ANTENNA HEIGHT (m)	TABLE ANGLE (Degree)	RAW VALUE (dBuV)	CORRECTION FACTOR (dB/m)
1	2310.00	57.7 PK	74.0	-16.3	1.14 V	173	63.72	-6.02
2	2310.00	44.3 AV	54.0	-9.7	1.14 V	173	50.32	-6.02
3	2312.72	58.3 PK	74.0	-15.7	1.16 V	179	64.30	-6.00
4	2312.72	53.8 AV	54.0	-0.2	1.16 V	179	59.80	-6.00
5	*2437.00	121.1 PK			1.14 V	173	126.80	-5.70
6	*2437.00	118.6 AV			1.14 V	173	124.30	-5.70
7	2483.50	59.3 PK	74.0	-14.7	1.14 V	173	64.79	-5.49
8	2483.50	46.8 AV	54.0	-7.2	1.14 V	173	52.29	-5.49
9	#2515.20	59.1 PK	101.1	-42.0	1.17 V	145	64.48	-5.38
10	#2515.20	52.5 AV	98.6	-46.1	1.17 V	145	57.88	-5.38
11	4874.00	48.4 PK	74.0	-25.6	1.28 V	92	45.00	3.40
12	4874.00	36.7 AV	54.0	-17.3	1.28 V	92	33.30	3.40
13	7311.00	51.9 PK	74.0	-22.1	1.00 V	135	44.14	7.76
14	7311.00	39.3 AV	54.0	-14.7	1.00 V	135	31.54	7.76

REMARKS:

1. Emission Level(dBuV/m) = Raw Value(dBuV) + Correction Factor(dB/m)
2. Correction Factor(dB/m) = Antenna Factor(dB/m) + Cable Factor(dB) – Pre-Amplifier Factor(dB)
3. The other emission levels were very low against the limit.
4. Margin value = Emission Level – Limit value
5. " * ": Fundamental frequency.
6. " # ": The radiated frequency is out of the restricted band.



A D T

CHANNEL	TX Channel 11	DETECTOR FUNCTION	Peak (PK)
FREQUENCY RANGE	1GHz ~ 25GHz		Average (AV)

ANTENNA POLARITY & TEST DISTANCE: HORIZONTAL AT 3 M

NO.	FREQ. (MHz)	EMISSION LEVEL (dBuV/m)	LIMIT (dBuV/m)	MARGIN (dB)	ANTENNA HEIGHT (m)	TABLE ANGLE (Degree)	RAW VALUE (dBuV)	CORRECTION FACTOR (dB/m)
1	2381.00	52.4 PK	74.0	-21.6	1.55 H	287	58.29	-5.89
2	2381.00	45.4 AV	54.0	-8.6	1.55 H	287	51.29	-5.89
3	*2462.00	105.1 PK			1.67 H	356	110.69	-5.59
4	*2462.00	102.5 AV			1.67 H	356	108.09	-5.59
5	2500.00	50.1 PK	74.0	-23.9	1.42 H	305	55.53	-5.43
6	2500.00	44.1 AV	54.0	-9.9	1.42 H	305	49.53	-5.43
7	4924.00	47.6 PK	74.0	-26.4	1.08 H	122	44.21	3.39
8	4924.00	35.9 AV	54.0	-18.1	1.08 H	122	32.51	3.39
9	7386.00	51.6 PK	74.0	-22.4	1.18 H	81	43.55	8.05
10	7386.00	38.4 AV	54.0	-15.6	1.18 H	81	30.35	8.05

ANTENNA POLARITY & TEST DISTANCE: VERTICAL AT 3 M

NO.	FREQ. (MHz)	EMISSION LEVEL (dBuV/m)	LIMIT (dBuV/m)	MARGIN (dB)	ANTENNA HEIGHT (m)	TABLE ANGLE (Degree)	RAW VALUE (dBuV)	CORRECTION FACTOR (dB/m)
1	2381.00	60.2 PK	74.0	-13.8	1.43 V	172	66.09	-5.89
2	2381.00	53.8 AV	54.0	-0.2	1.43 V	172	59.69	-5.89
3	*2462.00	116.7 PK			1.16 V	189	122.29	-5.59
4	*2462.00	114.4 AV			1.16 V	189	119.99	-5.59
5	2500.00	56.4 PK	74.0	-17.6	1.14 V	166	61.83	-5.43
6	2500.00	48.2 AV	54.0	-5.8	1.14 V	166	53.63	-5.43
7	4924.00	48.2 PK	74.0	-25.8	1.33 V	103	44.81	3.39
8	4924.00	36.3 AV	54.0	-17.7	1.33 V	103	32.91	3.39
9	7386.00	51.4 PK	74.0	-22.6	1.00 V	138	43.35	8.05
10	7386.00	38.9 AV	54.0	-15.1	1.00 V	138	30.85	8.05

REMARKS:

1. Emission Level(dBuV/m) = Raw Value(dBuV) + Correction Factor(dB/m)
2. Correction Factor(dB/m) = Antenna Factor(dB/m) + Cable Factor(dB) – Pre-Amplifier Factor(dB)
3. The other emission levels were very low against the limit.
4. Margin value = Emission Level – Limit value
5. " * ": Fundamental frequency.



A D T

802.11g

CHANNEL	TX Channel 1	DETECTOR FUNCTION	Peak (PK)
FREQUENCY RANGE	1GHz ~ 25GHz		Average (AV)

ANTENNA POLARITY & TEST DISTANCE: HORIZONTAL AT 3 M

NO.	FREQ. (MHz)	EMISSION LEVEL (dBuV/m)	LIMIT (dBuV/m)	MARGIN (dB)	ANTENNA HEIGHT (m)	TABLE ANGLE (Degree)	RAW VALUE (dBuV)	CORRECTION FACTOR (dB/m)
1	2390.00	65.4 PK	74.0	-8.6	1.65 H	351	71.27	-5.87
2	2390.00	42.2 AV	54.0	-11.8	1.65 H	351	48.07	-5.87
3	*2412.00	108.3 PK			1.65 H	351	114.10	-5.80
4	*2412.00	98.3 AV			1.65 H	351	104.10	-5.80
5	2487.40	54.8 PK	74.0	-19.2	1.55 H	342	60.29	-5.49
6	2487.40	45.5 AV	54.0	-8.5	1.55 H	342	50.99	-5.49
7	4824.00	47.4 PK	74.0	-26.6	1.13 H	111	43.98	3.42
8	4824.00	35.8 AV	54.0	-18.2	1.13 H	111	32.38	3.42

ANTENNA POLARITY & TEST DISTANCE: VERTICAL AT 3 M

NO.	FREQ. (MHz)	EMISSION LEVEL (dBuV/m)	LIMIT (dBuV/m)	MARGIN (dB)	ANTENNA HEIGHT (m)	TABLE ANGLE (Degree)	RAW VALUE (dBuV)	CORRECTION FACTOR (dB/m)
1	2390.00	73.4 PK	74.0	-0.6	1.00 V	167	79.27	-5.87
2	2390.00	50.4 AV	54.0	-3.6	1.00 V	167	56.27	-5.87
3	*2412.00	119.9 PK			1.00 V	167	125.70	-5.80
4	*2412.00	110.2 AV			1.00 V	167	116.00	-5.80
5	2487.40	61.2 PK	74.0	-12.8	1.00 V	145	66.69	-5.49
6	2487.40	49.7 AV	54.0	-4.3	1.00 V	145	55.19	-5.49
7	4824.00	48.3 PK	74.0	-25.7	1.35 V	112	44.88	3.42
8	4824.00	36.6 AV	54.0	-17.4	1.35 V	112	33.18	3.42

REMARKS:

1. Emission Level(dBuV/m) = Raw Value(dBuV) + Correction Factor(dB/m)
2. Correction Factor(dB/m) = Antenna Factor(dB/m) + Cable Factor(dB) – Pre-Amplifier Factor(dB)
3. The other emission levels were very low against the limit.
4. Margin value = Emission Level – Limit value
5. " * ": Fundamental frequency.



A D T

CHANNEL	TX Channel 6	DETECTOR FUNCTION	Peak (PK)
FREQUENCY RANGE	1GHz ~ 25GHz		Average (AV)

ANTENNA POLARITY & TEST DISTANCE: HORIZONTAL AT 3 M

NO.	FREQ. (MHz)	EMISSION LEVEL (dBuV/m)	LIMIT (dBuV/m)	MARGIN (dB)	ANTENNA HEIGHT (m)	TABLE ANGLE (Degree)	RAW VALUE (dBuV)	CORRECTION FACTOR (dB/m)
1	2390.00	65.9 PK	74.0	-8.1	1.62 H	355	71.77	-5.87
2	2390.00	43.5 AV	54.0	-10.5	1.62 H	355	49.37	-5.87
3	*2437.00	111.7 PK			1.62 H	355	117.40	-5.70
4	*2437.00	101.6 AV			1.62 H	355	107.30	-5.70
5	2483.50	61.6 PK	74.0	-12.4	1.43 H	289	67.09	-5.49
6	2483.50	43.4 AV	54.0	-10.6	1.43 H	289	48.89	-5.49
7	4874.00	47.1 PK	74.0	-26.9	1.12 H	126	43.70	3.40
8	4874.00	35.7 AV	54.0	-18.3	1.12 H	126	32.30	3.40
9	7311.00	51.9 PK	74.0	-22.1	1.19 H	74	44.14	7.76
10	7311.00	38.8 AV	54.0	-15.2	1.19 H	74	31.04	7.76

ANTENNA POLARITY & TEST DISTANCE: VERTICAL AT 3 M

NO.	FREQ. (MHz)	EMISSION LEVEL (dBuV/m)	LIMIT (dBuV/m)	MARGIN (dB)	ANTENNA HEIGHT (m)	TABLE ANGLE (Degree)	RAW VALUE (dBuV)	CORRECTION FACTOR (dB/m)
1	2390.00	73.8 PK	74.0	-0.2	1.09 V	195	79.67	-5.87
2	2390.00	51.5 AV	54.0	-2.5	1.09 V	195	57.37	-5.87
3	*2437.00	123.4 PK			1.09 V	195	129.10	-5.70
4	*2437.00	113.7 AV			1.09 V	195	119.40	-5.70
5	2483.50	67.8 PK	74.0	-6.2	1.55 V	202	73.29	-5.49
6	2483.50	51.3 AV	54.0	-2.7	1.55 V	202	56.79	-5.49
7	4874.00	48.0 PK	74.0	-26.0	1.35 V	101	44.60	3.40
8	4874.00	36.3 AV	54.0	-17.7	1.35 V	101	32.90	3.40
9	7311.00	51.3 PK	74.0	-22.7	1.00 V	122	43.54	7.76
10	7311.00	38.5 AV	54.0	-15.5	1.00 V	122	30.74	7.76

REMARKS:

1. Emission Level(dBuV/m) = Raw Value(dBuV) + Correction Factor(dB/m)
2. Correction Factor(dB/m) = Antenna Factor(dB/m) + Cable Factor(dB) – Pre-Amplifier Factor(dB)
3. The other emission levels were very low against the limit.
4. Margin value = Emission Level – Limit value
5. " * ": Fundamental frequency.



A D T

CHANNEL	TX Channel 11	DETECTOR FUNCTION	Peak (PK)
FREQUENCY RANGE	1GHz ~ 25GHz		Average (AV)

ANTENNA POLARITY & TEST DISTANCE: HORIZONTAL AT 3 M

NO.	FREQ. (MHz)	EMISSION LEVEL (dBuV/m)	LIMIT (dBuV/m)	MARGIN (dB)	ANTENNA HEIGHT (m)	TABLE ANGLE (Degree)	RAW VALUE (dBuV)	CORRECTION FACTOR (dB/m)
1	2383.00	55.8 PK	74.0	-18.2	1.38 H	332	61.68	-5.88
2	2383.00	42.8 AV	54.0	-11.2	1.38 H	332	48.68	-5.88
3	*2462.00	107.3 PK			1.61 H	347	112.89	-5.59
4	*2462.00	97.4 AV			1.61 H	347	102.99	-5.59
5	2483.50	65.6 PK	74.0	-8.4	1.61 H	347	71.09	-5.49
6	2483.50	44.6 AV	54.0	-9.4	1.61 H	347	50.09	-5.49
7	4924.00	46.7 PK	74.0	-27.3	1.11 H	131	43.31	3.39
8	4924.00	35.5 AV	54.0	-18.5	1.11 H	131	32.11	3.39
9	7386.00	52.2 PK	74.0	-21.8	1.19 H	67	44.15	8.05
10	7386.00	38.9 AV	54.0	-15.1	1.19 H	67	30.85	8.05

ANTENNA POLARITY & TEST DISTANCE: VERTICAL AT 3 M

NO.	FREQ. (MHz)	EMISSION LEVEL (dBuV/m)	LIMIT (dBuV/m)	MARGIN (dB)	ANTENNA HEIGHT (m)	TABLE ANGLE (Degree)	RAW VALUE (dBuV)	CORRECTION FACTOR (dB/m)
1	2383.00	61.6 PK	74.0	-12.4	1.11 V	183	67.48	-5.88
2	2383.00	50.8 AV	54.0	-3.2	1.11 V	183	56.68	-5.88
3	*2462.00	118.7 PK			1.36 V	188	124.29	-5.59
4	*2462.00	109.4 AV			1.36 V	188	114.99	-5.59
5	2483.50	73.6 PK	74.0	-0.4	1.36 V	188	79.09	-5.49
6	2483.50	52.5 AV	54.0	-1.5	1.36 V	188	57.99	-5.49
7	4924.00	48.2 PK	74.0	-25.8	1.33 V	85	44.81	3.39
8	4924.00	36.6 AV	54.0	-17.4	1.33 V	85	33.21	3.39
9	7386.00	51.7 PK	74.0	-22.3	1.02 V	123	43.65	8.05
10	7386.00	38.7 AV	54.0	-15.3	1.02 V	123	30.65	8.05

REMARKS:

1. Emission Level(dBuV/m) = Raw Value(dBuV) + Correction Factor(dB/m)
2. Correction Factor(dB/m) = Antenna Factor(dB/m) + Cable Factor(dB) – Pre-Amplifier Factor(dB)
3. The other emission levels were very low against the limit.
4. Margin value = Emission Level – Limit value
5. " * ": Fundamental frequency.



A D T

VHT20

CHANNEL	TX Channel 1	DETECTOR FUNCTION	Peak (PK)
FREQUENCY RANGE	1GHz ~ 25GHz		Average (AV)

ANTENNA POLARITY & TEST DISTANCE: HORIZONTAL AT 3 M

NO.	FREQ. (MHz)	EMISSION LEVEL (dBuV/m)	LIMIT (dBuV/m)	MARGIN (dB)	ANTENNA HEIGHT (m)	TABLE ANGLE (Degree)	RAW VALUE (dBuV)	CORRECTION FACTOR (dB/m)
1	2390.00	67.7 PK	74.0	-6.3	1.59 H	348	73.57	-5.87
2	2390.00	40.8 AV	54.0	-13.2	1.59 H	348	46.67	-5.87
3	*2412.00	107.4 PK			1.59 H	348	113.20	-5.80
4	*2412.00	96.8 AV			1.59 H	348	102.60	-5.80
5	2487.30	53.1 PK	74.0	-20.9	1.56 H	331	58.59	-5.49
6	2487.30	42.6 AV	54.0	-11.4	1.56 H	331	48.09	-5.49
7	4824.00	46.1 PK	74.0	-27.9	1.10 H	128	42.68	3.42
8	4824.00	35.1 AV	54.0	-18.9	1.10 H	128	31.68	3.42

ANTENNA POLARITY & TEST DISTANCE: VERTICAL AT 3 M

NO.	FREQ. (MHz)	EMISSION LEVEL (dBuV/m)	LIMIT (dBuV/m)	MARGIN (dB)	ANTENNA HEIGHT (m)	TABLE ANGLE (Degree)	RAW VALUE (dBuV)	CORRECTION FACTOR (dB/m)
1	2390.00	73.4 PK	74.0	-0.6	1.39 V	108	79.27	-5.87
2	2390.00	48.6 AV	54.0	-5.4	1.39 V	108	54.47	-5.87
3	*2412.00	118.8 PK			1.39 V	108	124.60	-5.80
4	*2412.00	108.6 AV			1.39 V	108	114.40	-5.80
5	2487.30	60.8 PK	74.0	-13.2	1.34 V	162	66.29	-5.49
6	2487.30	50.5 AV	54.0	-3.5	1.34 V	162	55.99	-5.49
7	4824.00	48.2 PK	74.0	-25.8	1.28 V	92	44.78	3.42
8	4824.00	36.9 AV	54.0	-17.1	1.28 V	92	33.48	3.42

REMARKS:

1. Emission Level(dBuV/m) = Raw Value(dBuV) + Correction Factor(dB/m)
2. Correction Factor(dB/m) = Antenna Factor(dB/m) + Cable Factor(dB) – Pre-Amplifier Factor(dB)
3. The other emission levels were very low against the limit.
4. Margin value = Emission Level – Limit value
5. " * ": Fundamental frequency.



A D T

CHANNEL	TX Channel 6	DETECTOR FUNCTION	Peak (PK)
FREQUENCY RANGE	1GHz ~ 25GHz		Average (AV)

ANTENNA POLARITY & TEST DISTANCE: HORIZONTAL AT 3 M

NO.	FREQ. (MHz)	EMISSION LEVEL (dBuV/m)	LIMIT (dBuV/m)	MARGIN (dB)	ANTENNA HEIGHT (m)	TABLE ANGLE (Degree)	RAW VALUE (dBuV)	CORRECTION FACTOR (dB/m)
1	2390.00	67.9 PK	74.0	-6.1	1.56 H	341	73.77	-5.87
2	2390.00	40.6 AV	54.0	-13.4	1.56 H	341	46.47	-5.87
3	*2437.00	111.9 PK			1.56 H	341	117.60	-5.70
4	*2437.00	101.1 AV			1.56 H	341	106.80	-5.70
5	2483.50	65.2 PK	74.0	-8.8	1.56 H	341	70.69	-5.49
6	2483.50	46.3 AV	54.0	-7.7	1.56 H	341	51.79	-5.49
7	4874.00	46.3 PK	74.0	-27.7	1.15 H	117	42.90	3.40
8	4874.00	35.4 AV	54.0	-18.6	1.15 H	117	32.00	3.40
9	7311.00	51.7 PK	74.0	-22.3	1.18 H	81	43.94	7.76
10	7311.00	38.5 AV	54.0	-15.5	1.18 H	81	30.74	7.76

ANTENNA POLARITY & TEST DISTANCE: VERTICAL AT 3 M

NO.	FREQ. (MHz)	EMISSION LEVEL (dBuV/m)	LIMIT (dBuV/m)	MARGIN (dB)	ANTENNA HEIGHT (m)	TABLE ANGLE (Degree)	RAW VALUE (dBuV)	CORRECTION FACTOR (dB/m)
1	2390.00	73.5 PK	74.0	-0.5	1.43 V	162	79.37	-5.87
2	2390.00	47.1 AV	54.0	-6.9	1.43 V	162	52.97	-5.87
3	*2437.00	123.4 PK			1.43 V	162	129.10	-5.70
4	*2437.00	112.8 AV			1.43 V	162	118.50	-5.70
5	2483.50	70.8 PK	74.0	-3.2	1.43 V	162	76.29	-5.49
6	2483.50	52.8 AV	54.0	-1.2	1.43 V	162	58.29	-5.49
7	4874.00	47.6 PK	74.0	-26.4	1.30 V	76	44.20	3.40
8	4874.00	36.3 AV	54.0	-17.7	1.30 V	76	32.90	3.40
9	7311.00	51.7 PK	74.0	-22.3	1.05 V	123	43.94	7.76
10	7311.00	38.9 AV	54.0	-15.1	1.05 V	123	31.14	7.76

REMARKS:

1. Emission Level(dBuV/m) = Raw Value(dBuV) + Correction Factor(dB/m)
2. Correction Factor(dB/m) = Antenna Factor(dB/m) + Cable Factor(dB) – Pre-Amplifier Factor(dB)
3. The other emission levels were very low against the limit.
4. Margin value = Emission Level – Limit value
5. " * ": Fundamental frequency.



A D T

CHANNEL	TX Channel 11	DETECTOR FUNCTION	Peak (PK)
FREQUENCY RANGE	1GHz ~ 25GHz		Average (AV)

ANTENNA POLARITY & TEST DISTANCE: HORIZONTAL AT 3 M								
NO.	FREQ. (MHz)	EMISSION LEVEL (dBuV/m)	LIMIT (dBuV/m)	MARGIN (dB)	ANTENNA HEIGHT (m)	TABLE ANGLE (Degree)	RAW VALUE (dBuV)	CORRECTION FACTOR (dB/m)
1	2381.60	53.7 PK	74.0	-20.3	1.46 H	287	59.59	-5.89
2	2381.60	42.6 AV	54.0	-11.4	1.46 H	287	48.49	-5.89
3	*2462.00	106.6 PK			1.54 H	331	112.19	-5.59
4	*2462.00	96.3 AV			1.54 H	331	101.89	-5.59
5	2483.50	68.2 PK	74.0	-5.8	1.54 H	331	73.69	-5.49
6	2483.50	43.7 AV	54.0	-10.3	1.54 H	331	49.19	-5.49
7	4924.00	46.3 PK	74.0	-27.7	1.19 H	121	42.91	3.39
8	4924.00	35.3 AV	54.0	-18.7	1.19 H	121	31.91	3.39
9	7386.00	51.9 PK	74.0	-22.1	1.16 H	83	43.85	8.05
10	7386.00	38.6 AV	54.0	-15.4	1.16 H	83	30.55	8.05

ANTENNA POLARITY & TEST DISTANCE: VERTICAL AT 3 M								
NO.	FREQ. (MHz)	EMISSION LEVEL (dBuV/m)	LIMIT (dBuV/m)	MARGIN (dB)	ANTENNA HEIGHT (m)	TABLE ANGLE (Degree)	RAW VALUE (dBuV)	CORRECTION FACTOR (dB/m)
1	2381.60	59.9 PK	74.0	-14.1	1.40 V	184	65.79	-5.89
2	2381.60	48.7 AV	54.0	-5.3	1.40 V	184	54.59	-5.89
3	*2462.00	118.0 PK			1.41 V	71	123.59	-5.59
4	*2462.00	108.0 AV			1.41 V	71	113.59	-5.59
5	2483.50	73.8 PK	74.0	-0.2	1.41 V	71	79.29	-5.49
6	2483.50	50.2 AV	54.0	-3.8	1.41 V	71	55.69	-5.49
7	4924.00	47.8 PK	74.0	-26.2	1.25 V	66	44.41	3.39
8	4924.00	36.3 AV	54.0	-17.7	1.25 V	66	32.91	3.39
9	7386.00	51.9 PK	74.0	-22.1	1.07 V	135	43.85	8.05
10	7386.00	39.4 AV	54.0	-14.6	1.07 V	135	31.35	8.05

REMARKS:

1. Emission Level(dBuV/m) = Raw Value(dBuV) + Correction Factor(dB/m)
2. Correction Factor(dB/m) = Antenna Factor(dB/m) + Cable Factor(dB) – Pre-Amplifier Factor(dB)
3. The other emission levels were very low against the limit.
4. Margin value = Emission Level – Limit value
5. " * ": Fundamental frequency.



A D T

VHT40

CHANNEL	TX Channel 3	DETECTOR FUNCTION	Peak (PK)
FREQUENCY RANGE	1GHz ~ 25GHz		Average (AV)

ANTENNA POLARITY & TEST DISTANCE: HORIZONTAL AT 3 M

NO.	FREQ. (MHz)	EMISSION LEVEL (dBuV/m)	LIMIT (dBuV/m)	MARGIN (dB)	ANTENNA HEIGHT (m)	TABLE ANGLE (Degree)	RAW VALUE (dBuV)	CORRECTION FACTOR (dB/m)
1	2390.00	67.5 PK	74.0	-6.5	1.59 H	316	73.37	-5.87
2	2390.00	47.4 AV	54.0	-6.6	1.59 H	316	53.27	-5.87
3	*2422.00	103.9 PK			1.59 H	316	109.66	-5.76
4	*2422.00	92.5 AV			1.59 H	316	98.26	-5.76
5	2497.00	53.4 PK	74.0	-20.6	1.59 H	316	58.84	-5.44
6	2497.00	40.8 AV	54.0	-13.2	1.59 H	316	46.24	-5.44
7	4844.00	45.6 PK	74.0	-28.4	1.18 H	135	42.19	3.41
8	4844.00	34.9 AV	54.0	-19.1	1.18 H	135	31.49	3.41
9	7266.00	51.9 PK	74.0	-22.1	1.16 H	80	44.32	7.58
10	7266.00	38.3 AV	54.0	-15.7	1.16 H	80	30.72	7.58

ANTENNA POLARITY & TEST DISTANCE: VERTICAL AT 3 M

NO.	FREQ. (MHz)	EMISSION LEVEL (dBuV/m)	LIMIT (dBuV/m)	MARGIN (dB)	ANTENNA HEIGHT (m)	TABLE ANGLE (Degree)	RAW VALUE (dBuV)	CORRECTION FACTOR (dB/m)
1	2390.00	73.4 PK	74.0	-0.6	1.19 V	155	79.27	-5.87
2	2390.00	53.6 AV	54.0	-0.4	1.19 V	155	59.47	-5.87
3	*2422.00	115.4 PK			1.19 V	155	121.16	-5.76
4	*2422.00	104.2 AV			1.19 V	155	109.96	-5.76
5	2497.00	59.2 PK	74.0	-14.8	1.19 V	155	64.64	-5.44
6	2497.00	46.8 AV	54.0	-7.2	1.19 V	155	52.24	-5.44
7	4844.00	48.1 PK	74.0	-25.9	1.21 V	78	44.69	3.41
8	4844.00	36.5 AV	54.0	-17.5	1.21 V	78	33.09	3.41
9	7266.00	51.4 PK	74.0	-22.6	1.13 V	131	43.82	7.58
10	7266.00	39.0 AV	54.0	-15.0	1.13 V	131	31.42	7.58

REMARKS:

1. Emission Level(dBuV/m) = Raw Value(dBuV) + Correction Factor(dB/m)
2. Correction Factor(dB/m) = Antenna Factor(dB/m) + Cable Factor(dB) – Pre-Amplifier Factor(dB)
3. The other emission levels were very low against the limit.
4. Margin value = Emission Level – Limit value
5. " * ": Fundamental frequency.



A D T

CHANNEL	TX Channel 6	DETECTOR FUNCTION	Peak (PK)
FREQUENCY RANGE	1GHz ~ 25GHz		Average (AV)

ANTENNA POLARITY & TEST DISTANCE: HORIZONTAL AT 3 M

NO.	FREQ. (MHz)	EMISSION LEVEL (dBuV/m)	LIMIT (dBuV/m)	MARGIN (dB)	ANTENNA HEIGHT (m)	TABLE ANGLE (Degree)	RAW VALUE (dBuV)	CORRECTION FACTOR (dB/m)
1	2390.00	61.4 PK	74.0	-12.6	1.58 H	308	67.27	-5.87
2	2390.00	41.8 AV	54.0	-12.2	1.58 H	308	47.67	-5.87
3	*2437.00	105.6 PK			1.58 H	308	111.30	-5.70
4	*2437.00	93.4 AV			1.58 H	308	99.10	-5.70
5	2483.50	67.6 PK	74.0	-6.4	1.58 H	308	73.09	-5.49
6	2483.50	45.1 AV	54.0	-8.9	1.58 H	308	50.59	-5.49
7	4874.00	46.3 PK	74.0	-27.7	1.21 H	126	42.90	3.40
8	4874.00	35.3 AV	54.0	-18.7	1.21 H	126	31.90	3.40
9	7311.00	51.5 PK	74.0	-22.5	1.11 H	93	43.74	7.76
10	7311.00	38.0 AV	54.0	-16.0	1.11 H	93	30.24	7.76

ANTENNA POLARITY & TEST DISTANCE: VERTICAL AT 3 M

NO.	FREQ. (MHz)	EMISSION LEVEL (dBuV/m)	LIMIT (dBuV/m)	MARGIN (dB)	ANTENNA HEIGHT (m)	TABLE ANGLE (Degree)	RAW VALUE (dBuV)	CORRECTION FACTOR (dB/m)
1	2390.00	67.6 PK	74.0	-6.4	1.19 V	179	73.47	-5.87
2	2390.00	47.7 AV	54.0	-6.3	1.19 V	179	53.57	-5.87
3	*2437.00	116.5 PK			1.19 V	179	122.20	-5.70
4	*2437.00	104.9 AV			1.19 V	179	110.60	-5.70
5	2483.50	73.6 PK	74.0	-0.4	1.19 V	179	79.09	-5.49
6	2483.50	50.6 AV	54.0	-3.4	1.19 V	179	56.09	-5.49
7	4874.00	48.1 PK	74.0	-25.9	1.23 V	62	44.70	3.40
8	4874.00	36.6 AV	54.0	-17.4	1.23 V	62	33.20	3.40
9	7311.00	52.1 PK	74.0	-21.9	1.10 V	137	44.34	7.76
10	7311.00	39.4 AV	54.0	-14.6	1.10 V	137	31.64	7.76

REMARKS:

1. Emission Level(dBuV/m) = Raw Value(dBuV) + Correction Factor(dB/m)
2. Correction Factor(dB/m) = Antenna Factor(dB/m) + Cable Factor(dB) – Pre-Amplifier Factor(dB)
3. The other emission levels were very low against the limit.
4. Margin value = Emission Level – Limit value
5. " * ": Fundamental frequency.



A D T

CHANNEL	TX Channel 9	DETECTOR FUNCTION	Peak (PK)
FREQUENCY RANGE	1GHz ~ 25GHz		Average (AV)

ANTENNA POLARITY & TEST DISTANCE: HORIZONTAL AT 3 M

NO.	FREQ. (MHz)	EMISSION LEVEL (dBuV/m)	LIMIT (dBuV/m)	MARGIN (dB)	ANTENNA HEIGHT (m)	TABLE ANGLE (Degree)	RAW VALUE (dBuV)	CORRECTION FACTOR (dB/m)
1	*2452.00	102.3 PK			1.63 H	313	107.94	-5.64
2	*2452.00	91.3 AV			1.63 H	313	96.94	-5.64
3	2483.50	64.3 PK	74.0	-9.7	1.63 H	313	69.79	-5.49
4	2483.50	48.2 AV	54.0	-5.8	1.63 H	313	53.69	-5.49
5	4904.00	46.2 PK	74.0	-27.8	1.24 H	112	42.81	3.39
6	4904.00	35.0 AV	54.0	-19.0	1.24 H	112	31.61	3.39
7	7356.00	51.8 PK	74.0	-22.2	1.13 H	109	43.86	7.94
8	7356.00	38.3 AV	54.0	-15.7	1.13 H	109	30.36	7.94

ANTENNA POLARITY & TEST DISTANCE: VERTICAL AT 3 M

NO.	FREQ. (MHz)	EMISSION LEVEL (dBuV/m)	LIMIT (dBuV/m)	MARGIN (dB)	ANTENNA HEIGHT (m)	TABLE ANGLE (Degree)	RAW VALUE (dBuV)	CORRECTION FACTOR (dB/m)
1	*2452.00	113.9 PK			1.18 V	187	119.54	-5.64
2	*2452.00	102.8 AV			1.18 V	187	108.44	-5.64
3	2483.50	70.0 PK	74.0	-4.0	1.18 V	187	75.49	-5.49
4	2483.50	53.4 AV	54.0	-0.6	1.18 V	187	58.89	-5.49
5	4904.00	47.9 PK	74.0	-26.1	1.26 V	62	44.51	3.39
6	4904.00	36.2 AV	54.0	-17.8	1.26 V	62	32.81	3.39
7	7356.00	51.6 PK	74.0	-22.4	1.10 V	142	43.66	7.94
8	7356.00	39.1 AV	54.0	-14.9	1.10 V	142	31.16	7.94

REMARKS:

1. Emission Level(dBuV/m) = Raw Value(dBuV) + Correction Factor(dB/m)
2. Correction Factor(dB/m) = Antenna Factor(dB/m) + Cable Factor(dB) – Pre-Amplifier Factor(dB)
3. The other emission levels were very low against the limit.
4. Margin value = Emission Level – Limit value
5. " * ": Fundamental frequency.



A D T

4.2.8 TEST RESULTS (MODE 2)

VHT20

CHANNEL	TX Channel 1	DETECTOR FUNCTION	Peak (PK)
FREQUENCY RANGE	1GHz ~ 25GHz		Average (AV)

ANTENNA POLARITY & TEST DISTANCE: HORIZONTAL AT 3 M

NO.	FREQ. (MHz)	EMISSION LEVEL (dBuV/m)	LIMIT (dBuV/m)	MARGIN (dB)	ANTENNA HEIGHT (m)	TABLE ANGLE (Degree)	RAW VALUE (dBuV)	CORRECTION FACTOR (dB/m)
1	2390.00	68.2 PK	74.0	-5.8	1.71 H	358	74.07	-5.87
2	2390.00	45.6 AV	54.0	-8.4	1.71 H	358	51.47	-5.87
3	*2412.00	107.9 PK			1.71 H	358	113.70	-5.80
4	*2412.00	96.3 AV			1.71 H	358	102.10	-5.80
5	2487.30	55.7 PK	74.0	-18.3	1.64 H	344	61.19	-5.49
6	2487.30	43.7 AV	54.0	-10.3	1.64 H	344	49.19	-5.49
7	4824.00	46.8 PK	74.0	-27.2	1.00 H	126	43.38	3.42
8	4824.00	35.7 AV	54.0	-18.3	1.00 H	126	32.28	3.42

ANTENNA POLARITY & TEST DISTANCE: VERTICAL AT 3 M

NO.	FREQ. (MHz)	EMISSION LEVEL (dBuV/m)	LIMIT (dBuV/m)	MARGIN (dB)	ANTENNA HEIGHT (m)	TABLE ANGLE (Degree)	RAW VALUE (dBuV)	CORRECTION FACTOR (dB/m)
1	2390.00	73.4 PK	74.0	-0.6	1.08 V	144	79.27	-5.87
2	2390.00	52.4 AV	54.0	-1.6	1.08 V	144	58.27	-5.87
3	*2412.00	119.2 PK			1.08 V	144	125.00	-5.80
4	*2412.00	108.1 AV			1.08 V	144	113.90	-5.80
5	2487.30	61.1 PK	74.0	-12.9	1.10 V	193	66.59	-5.49
6	2487.30	50.3 AV	54.0	-3.7	1.10 V	193	55.79	-5.49
7	4824.00	48.5 PK	74.0	-25.5	1.31 V	102	45.08	3.42
8	4824.00	36.5 AV	54.0	-17.5	1.31 V	102	33.08	3.42

REMARKS:

1. Emission Level(dBuV/m) = Raw Value(dBuV) + Correction Factor(dB/m)
2. Correction Factor(dB/m) = Antenna Factor(dB/m) + Cable Factor(dB) – Pre-Amplifier Factor(dB)
3. The other emission levels were very low against the limit.
4. Margin value = Emission Level – Limit value
5. " * ": Fundamental frequency.



A D T

CHANNEL	TX Channel 6	DETECTOR FUNCTION	Peak (PK)
FREQUENCY RANGE	1GHz ~ 25GHz		Average (AV)

ANTENNA POLARITY & TEST DISTANCE: HORIZONTAL AT 3 M

NO.	FREQ. (MHz)	EMISSION LEVEL (dBuV/m)	LIMIT (dBuV/m)	MARGIN (dB)	ANTENNA HEIGHT (m)	TABLE ANGLE (Degree)	RAW VALUE (dBuV)	CORRECTION FACTOR (dB/m)
1	2312.00	58.7 PK	74.0	-15.3	1.72 H	355	64.70	-6.00
2	2312.00	44.6 AV	54.0	-9.4	1.72 H	355	50.60	-6.00
3	2390.00	68.7 PK	74.0	-5.3	1.72 H	355	74.57	-5.87
4	2390.00	46.4 AV	54.0	-7.6	1.72 H	355	52.27	-5.87
5	*2437.00	113.6 PK			1.72 H	355	119.30	-5.70
6	*2437.00	101.8 AV			1.72 H	355	107.50	-5.70
7	2483.50	64.2 PK	74.0	-9.8	1.72 H	355	69.69	-5.49
8	2483.50	47.9 AV	54.0	-6.1	1.72 H	355	53.39	-5.49
9	4874.00	46.7 PK	74.0	-27.3	1.06 H	134	43.30	3.40
10	4874.00	35.5 AV	54.0	-18.5	1.06 H	134	32.10	3.40
11	7311.00	52.5 PK	74.0	-21.5	1.27 H	75	44.74	7.76
12	7311.00	39.3 AV	54.0	-14.7	1.27 H	75	31.54	7.76

ANTENNA POLARITY & TEST DISTANCE: VERTICAL AT 3 M

NO.	FREQ. (MHz)	EMISSION LEVEL (dBuV/m)	LIMIT (dBuV/m)	MARGIN (dB)	ANTENNA HEIGHT (m)	TABLE ANGLE (Degree)	RAW VALUE (dBuV)	CORRECTION FACTOR (dB/m)
1	2312.00	64.1 PK	74.0	-9.9	1.00 V	149	70.10	-6.00
2	2312.00	49.1 AV	54.0	-4.9	1.00 V	149	55.10	-6.00
3	2390.00	73.8 PK	74.0	-0.2	1.00 V	146	79.67	-5.87
4	2390.00	51.5 AV	54.0	-2.5	1.00 V	146	57.37	-5.87
5	*2437.00	124.5 PK			1.00 V	146	130.20	-5.70
6	*2437.00	113.4 AV			1.00 V	146	119.10	-5.70
7	2483.50	69.0 PK	74.0	-5.0	1.00 V	149	74.49	-5.49
8	2483.50	53.8 AV	54.0	-0.2	1.00 V	149	59.29	-5.49
9	4874.00	48.4 PK	74.0	-25.6	1.29 V	104	45.00	3.40
10	4874.00	36.7 AV	54.0	-17.3	1.29 V	104	33.30	3.40
11	7311.00	51.9 PK	74.0	-22.1	1.05 V	129	44.14	7.76
12	7311.00	39.1 AV	54.0	-14.9	1.05 V	129	31.34	7.76

REMARKS:

1. Emission Level(dBuV/m) = Raw Value(dBuV) + Correction Factor(dB/m)
2. Correction Factor(dB/m) = Antenna Factor(dB/m) + Cable Factor(dB) – Pre-Amplifier Factor(dB)
3. The other emission levels were very low against the limit.
4. Margin value = Emission Level – Limit value
5. " * ": Fundamental frequency.



A D T

CHANNEL	TX Channel 11	DETECTOR FUNCTION	Peak (PK)
FREQUENCY RANGE	1GHz ~ 25GHz		Average (AV)

ANTENNA POLARITY & TEST DISTANCE: HORIZONTAL AT 3 M

NO.	FREQ. (MHz)	EMISSION LEVEL (dBuV/m)	LIMIT (dBuV/m)	MARGIN (dB)	ANTENNA HEIGHT (m)	TABLE ANGLE (Degree)	RAW VALUE (dBuV)	CORRECTION FACTOR (dB/m)
1	2381.60	56.6 PK	74.0	-17.4	1.65 H	351	62.49	-5.89
2	2381.60	44.1 AV	54.0	-9.9	1.65 H	351	49.99	-5.89
3	*2462.00	108.4 PK			1.67 H	348	113.99	-5.59
4	*2462.00	96.5 AV			1.67 H	348	102.09	-5.59
5	2483.50	68.1 PK	74.0	-5.9	1.67 H	348	73.59	-5.49
6	2483.50	46.2 AV	54.0	-7.8	1.67 H	348	51.69	-5.49
7	4924.00	46.5 PK	74.0	-27.5	1.04 H	139	43.11	3.39
8	4924.00	35.2 AV	54.0	-18.8	1.04 H	139	31.81	3.39
9	7386.00	52.5 PK	74.0	-21.5	1.30 H	89	44.45	8.05
10	7386.00	39.3 AV	54.0	-14.7	1.30 H	89	31.25	8.05

ANTENNA POLARITY & TEST DISTANCE: VERTICAL AT 3 M

NO.	FREQ. (MHz)	EMISSION LEVEL (dBuV/m)	LIMIT (dBuV/m)	MARGIN (dB)	ANTENNA HEIGHT (m)	TABLE ANGLE (Degree)	RAW VALUE (dBuV)	CORRECTION FACTOR (dB/m)
1	2381.60	61.9 PK	74.0	-12.1	1.00 V	146	67.79	-5.89
2	2381.60	50.2 AV	54.0	-3.8	1.00 V	146	56.09	-5.89
3	*2462.00	120.1 PK			1.00 V	144	125.69	-5.59
4	*2462.00	108.2 AV			1.00 V	144	113.79	-5.59
5	2483.50	73.4 PK	74.0	-0.6	1.00 V	144	78.89	-5.49
6	2483.50	50.9 AV	54.0	-3.1	1.00 V	144	56.39	-5.49
7	4924.00	48.2 PK	74.0	-25.8	1.30 V	90	44.81	3.39
8	4924.00	36.4 AV	54.0	-17.6	1.30 V	90	33.01	3.39
9	7386.00	52.5 PK	74.0	-21.5	1.03 V	118	44.45	8.05
10	7386.00	39.4 AV	54.0	-14.6	1.03 V	118	31.35	8.05

REMARKS:

1. Emission Level(dBuV/m) = Raw Value(dBuV) + Correction Factor(dB/m)
2. Correction Factor(dB/m) = Antenna Factor(dB/m) + Cable Factor(dB) – Pre-Amplifier Factor(dB)
3. The other emission levels were very low against the limit.
4. Margin value = Emission Level – Limit value
5. " * ": Fundamental frequency.



A D T

VHT40

CHANNEL	TX Channel 3	DETECTOR FUNCTION	Peak (PK)
FREQUENCY RANGE	1GHz ~ 25GHz		Average (AV)

ANTENNA POLARITY & TEST DISTANCE: HORIZONTAL AT 3 M

NO.	FREQ. (MHz)	EMISSION LEVEL (dBuV/m)	LIMIT (dBuV/m)	MARGIN (dB)	ANTENNA HEIGHT (m)	TABLE ANGLE (Degree)	RAW VALUE (dBuV)	CORRECTION FACTOR (dB/m)
1	2390.00	63.1 PK	74.0	-10.9	1.63 H	345	68.97	-5.87
2	2390.00	46.8 AV	54.0	-7.2	1.63 H	345	52.67	-5.87
3	*2422.00	110.6 PK			1.63 H	345	116.36	-5.76
4	*2422.00	93.7 AV			1.63 H	345	99.46	-5.76
5	2497.00	55.3 PK	74.0	-18.7	1.54 H	308	60.74	-5.44
6	2497.00	43.1 AV	54.0	-10.9	1.54 H	308	48.54	-5.44
7	4844.00	46.3 PK	74.0	-27.7	1.06 H	147	42.89	3.41
8	4844.00	35.2 AV	54.0	-18.8	1.06 H	147	31.79	3.41
9	7266.00	52.5 PK	74.0	-21.5	1.30 H	97	44.92	7.58
10	7266.00	39.4 AV	54.0	-14.6	1.30 H	97	31.82	7.58

ANTENNA POLARITY & TEST DISTANCE: VERTICAL AT 3 M

NO.	FREQ. (MHz)	EMISSION LEVEL (dBuV/m)	LIMIT (dBuV/m)	MARGIN (dB)	ANTENNA HEIGHT (m)	TABLE ANGLE (Degree)	RAW VALUE (dBuV)	CORRECTION FACTOR (dB/m)
1	2390.00	68.1 PK	74.0	-5.9	1.00 V	168	73.97	-5.87
2	2390.00	53.8 AV	54.0	-0.2	1.00 V	168	59.67	-5.87
3	*2422.00	116.4 PK			1.00 V	168	122.16	-5.76
4	*2422.00	104.3 AV			1.00 V	168	110.06	-5.76
5	2497.00	58.1 PK	74.0	-15.9	1.00 V	202	63.54	-5.44
6	2497.00	47.2 AV	54.0	-6.8	1.00 V	202	52.64	-5.44
7	4844.00	47.7 PK	74.0	-26.3	1.26 V	97	44.29	3.41
8	4844.00	35.9 AV	54.0	-18.1	1.26 V	97	32.49	3.41
9	7266.00	51.5 PK	74.0	-22.5	1.02 V	126	43.92	7.58
10	7266.00	38.8 AV	54.0	-15.2	1.02 V	126	31.22	7.58

REMARKS:

1. Emission Level(dBuV/m) = Raw Value(dBuV) + Correction Factor(dB/m)
2. Correction Factor(dB/m) = Antenna Factor(dB/m) + Cable Factor(dB) – Pre-Amplifier Factor(dB)
3. The other emission levels were very low against the limit.
4. Margin value = Emission Level – Limit value
5. " * ": Fundamental frequency.



A D T

CHANNEL	TX Channel 6	DETECTOR FUNCTION	Peak (PK)
FREQUENCY RANGE	1GHz ~ 25GHz		Average (AV)

ANTENNA POLARITY & TEST DISTANCE: HORIZONTAL AT 3 M

NO.	FREQ. (MHz)	EMISSION LEVEL (dBuV/m)	LIMIT (dBuV/m)	MARGIN (dB)	ANTENNA HEIGHT (m)	TABLE ANGLE (Degree)	RAW VALUE (dBuV)	CORRECTION FACTOR (dB/m)
1	2390.00	60.4 PK	74.0	-13.6	1.59 H	347	66.27	-5.87
2	2390.00	44.5 AV	54.0	-9.5	1.59 H	347	50.37	-5.87
3	*2437.00	110.8 PK			1.59 H	347	116.50	-5.70
4	*2437.00	93.3 AV			1.59 H	347	99.00	-5.70
5	2483.50	63.0 PK	74.0	-11.0	1.58 H	352	68.49	-5.49
6	2483.50	47.9 AV	54.0	-6.1	1.58 H	352	53.39	-5.49
7	4874.00	45.2 PK	74.0	-28.8	1.00 H	112	41.80	3.40
8	4874.00	34.5 AV	54.0	-19.5	1.00 H	112	31.10	3.40
9	7311.00	52.3 PK	74.0	-21.7	1.21 H	102	44.54	7.76
10	7311.00	39.6 AV	54.0	-14.4	1.21 H	102	31.84	7.76

ANTENNA POLARITY & TEST DISTANCE: VERTICAL AT 3 M

NO.	FREQ. (MHz)	EMISSION LEVEL (dBuV/m)	LIMIT (dBuV/m)	MARGIN (dB)	ANTENNA HEIGHT (m)	TABLE ANGLE (Degree)	RAW VALUE (dBuV)	CORRECTION FACTOR (dB/m)
1	2390.00	65.9 PK	74.0	-8.1	1.01 V	72	71.77	-5.87
2	2390.00	50.8 AV	54.0	-3.2	1.01 V	72	56.67	-5.87
3	*2437.00	116.7 PK			1.00 V	74	122.40	-5.70
4	*2437.00	105.3 AV			1.00 V	74	111.00	-5.70
5	2483.50	68.2 PK	74.0	-5.8	1.00 V	81	73.69	-5.49
6	2483.50	53.5 AV	54.0	-0.5	1.00 V	81	58.99	-5.49
7	4874.00	47.8 PK	74.0	-26.2	1.15 V	96	44.40	3.40
8	4874.00	36.1 AV	54.0	-17.9	1.15 V	96	32.70	3.40
9	7311.00	51.6 PK	74.0	-22.4	1.06 V	137	43.84	7.76
10	7311.00	39.0 AV	54.0	-15.0	1.06 V	137	31.24	7.76

REMARKS:

1. Emission Level(dBuV/m) = Raw Value(dBuV) + Correction Factor(dB/m)
2. Correction Factor(dB/m) = Antenna Factor(dB/m) + Cable Factor(dB) – Pre-Amplifier Factor(dB)
3. The other emission levels were very low against the limit.
4. Margin value = Emission Level – Limit value
5. " * ": Fundamental frequency.



A D T

CHANNEL	TX Channel 9	DETECTOR FUNCTION	Peak (PK)
FREQUENCY RANGE	1GHz ~ 25GHz		Average (AV)

ANTENNA POLARITY & TEST DISTANCE: HORIZONTAL AT 3 M

NO.	FREQ. (MHz)	EMISSION LEVEL (dBuV/m)	LIMIT (dBuV/m)	MARGIN (dB)	ANTENNA HEIGHT (m)	TABLE ANGLE (Degree)	RAW VALUE (dBuV)	CORRECTION FACTOR (dB/m)
1	*2452.00	107.5 PK			1.63 H	351	113.14	-5.64
2	*2452.00	91.7 AV			1.63 H	351	97.34	-5.64
3	2483.50	65.7 PK	74.0	-8.3	1.58 H	354	71.19	-5.49
4	2483.50	49.6 AV	54.0	-4.4	1.58 H	354	55.09	-5.49
5	4904.00	44.5 PK	74.0	-29.5	1.05 H	101	41.11	3.39
6	4904.00	34.1 AV	54.0	-19.9	1.05 H	101	30.71	3.39
7	7356.00	52.7 PK	74.0	-21.3	1.22 H	84	44.76	7.94
8	7356.00	39.8 AV	54.0	-14.2	1.22 H	84	31.86	7.94

ANTENNA POLARITY & TEST DISTANCE: VERTICAL AT 3 M

NO.	FREQ. (MHz)	EMISSION LEVEL (dBuV/m)	LIMIT (dBuV/m)	MARGIN (dB)	ANTENNA HEIGHT (m)	TABLE ANGLE (Degree)	RAW VALUE (dBuV)	CORRECTION FACTOR (dB/m)
1	*2452.00	113.6 PK			1.00 V	71	119.24	-5.64
2	*2452.00	102.2 AV			1.00 V	71	107.84	-5.64
3	2483.50	66.5 PK	74.0	-7.5	1.00 V	76	71.99	-5.49
4	2483.50	53.7 AV	54.0	-0.3	1.00 V	76	59.19	-5.49
5	4904.00	48.1 PK	74.0	-25.9	1.18 V	108	44.71	3.39
6	4904.00	36.4 AV	54.0	-17.6	1.18 V	108	33.01	3.39
7	7356.00	51.3 PK	74.0	-22.7	1.02 V	152	43.36	7.94
8	7356.00	38.7 AV	54.0	-15.3	1.02 V	152	30.76	7.94

REMARKS:

1. Emission Level(dBuV/m) = Raw Value(dBuV) + Correction Factor(dB/m)
2. Correction Factor(dB/m) = Antenna Factor(dB/m) + Cable Factor(dB) – Pre-Amplifier Factor(dB)
3. The other emission levels were very low against the limit.
4. Margin value = Emission Level – Limit value
5. " * ": Fundamental frequency.

4.3 6dB BANDWIDTH MEASUREMENT

4.3.1 LIMITS OF 6dB BANDWIDTH MEASUREMENT

The minimum of 6dB Bandwidth Measurement is 0.5 MHz.

4.3.2 TEST INSTRUMENTS

DESCRIPTION & MANUFACTURER	MODEL NO.	SERIAL NO.	CALIBRATED DATE	CALIBRATED UNTIL
SPECTRUM ANALYZER R&S	FSP 40	100060	May 08, 2014	May 07, 2015

Note:

1. The calibration interval of the above test instruments is 12 months and the calibrations are traceable to NML/ROC and NIST/USA.
2. Tested date : Dec. 08, 2014

4.3.3 TEST PROCEDURE

1. Set resolution bandwidth (RBW) = 100kHz.
2. Set the video bandwidth (VBW) $\geq 3 \times$ RBW, Detector = Peak.
3. Trace mode = max hold.
4. Sweep = auto couple.
5. Measure the maximum width of the emission that is constrained by the frequencies associated with the two amplitude points (upper and lower) that are attenuated by 6 dB relative to the maximum level measured in the fundamental emission

4.3.4 DEVIATION FROM TEST STANDARD

No deviation

4.3.5 TEST SETUP

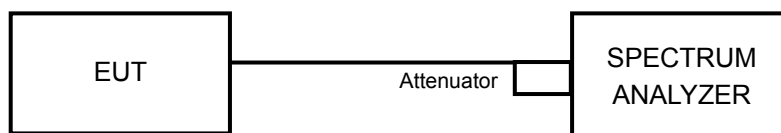

4.3.6 EUT OPERATING CONDITIONS

The software provided by client to enable the EUT under transmission condition continuously at lowest, middle and highest channel frequencies individually.



4.3.7 TEST RESULTS (MODE 1)

802.11b

CHANNEL	CHANNEL FREQUENCY (MHz)	6dB BANDWIDTH (MHz)			MINIMUM LIMIT (MHz)	PASS / FAIL
		CHAIN 0	CHAIN 1	CHAIN 2		
1	2412	9.07	9.02	8.57	0.5	PASS
6	2437	9.07	9.06	8.61	0.5	PASS
11	2462	8.56	8.59	8.58	0.5	PASS

802.11g

CHANNEL	CHANNEL FREQUENCY (MHz)	6dB BANDWIDTH (MHz)			MINIMUM LIMIT (MHz)	PASS / FAIL
		CHAIN 0	CHAIN 1	CHAIN 2		
1	2412	16.40	16.41	16.43	0.5	PASS
6	2437	16.43	16.40	16.44	0.5	PASS
11	2462	16.39	17.63	16.40	0.5	PASS

VHT20

CHANNEL	CHANNEL FREQUENCY (MHz)	6dB BANDWIDTH (MHz)			MINIMUM LIMIT (MHz)	PASS / FAIL
		CHAIN 0	CHAIN 1	CHAIN 2		
1	2412	17.64	17.65	17.65	0.5	PASS
6	2437	17.65	17.67	17.66	0.5	PASS
11	2462	17.63	17.66	17.63	0.5	PASS

VHT40

CHANNEL	CHANNEL FREQUENCY (MHz)	6dB BANDWIDTH (MHz)			MINIMUM LIMIT (MHz)	PASS / FAIL
		CHAIN 0	CHAIN 1	CHAIN 2		
3	2422	35.83	35.49	35.32	0.5	PASS
6	2437	36.47	36.49	36.47	0.5	PASS
9	2452	36.17	36.46	36.17	0.5	PASS



A D T

SPECTRUM PLOT OF WORST VALUE

802.11b / Chain (0): CH11

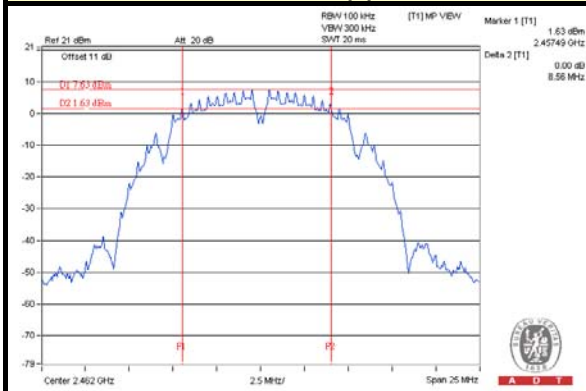

802.11g / Chain (0): CH11

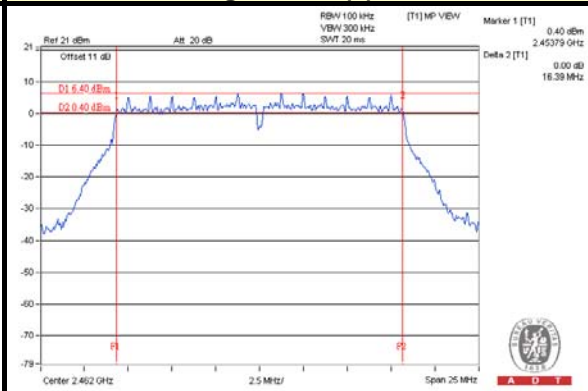

VHT20 / Chain (0): CH11

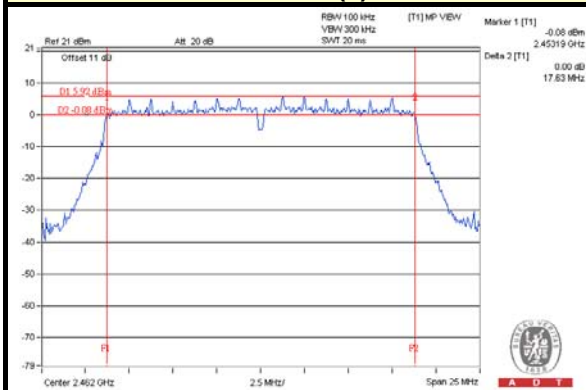

VHT40 / Chain (2): CH3

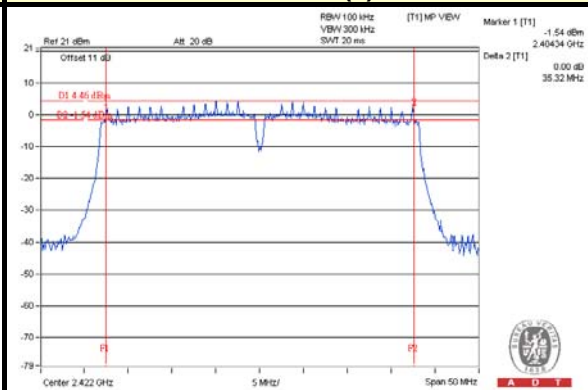

4.3.8 TEST RESULTS (MODE 2)

VHT20

CHANNEL	CHANNEL FREQUENCY (MHz)	6dB BANDWIDTH (MHz)			MINIMUM LIMIT (MHz)	PASS / FAIL
		CHAIN 0	CHAIN 1	CHAIN 2		
1	2412	17.37	17.65	17.62	0.5	PASS
6	2437	17.63	17.66	17.67	0.5	PASS
11	2462	17.38	17.66	17.63	0.5	PASS

VHT40

CHANNEL	CHANNEL FREQUENCY (MHz)	6dB BANDWIDTH (MHz)			MINIMUM LIMIT (MHz)	PASS / FAIL
		CHAIN 0	CHAIN 1	CHAIN 2		
3	2422	35.57	35.43	35.33	0.5	PASS
6	2437	36.46	36.46	36.48	0.5	PASS
9	2452	36.09	36.48	36.45	0.5	PASS

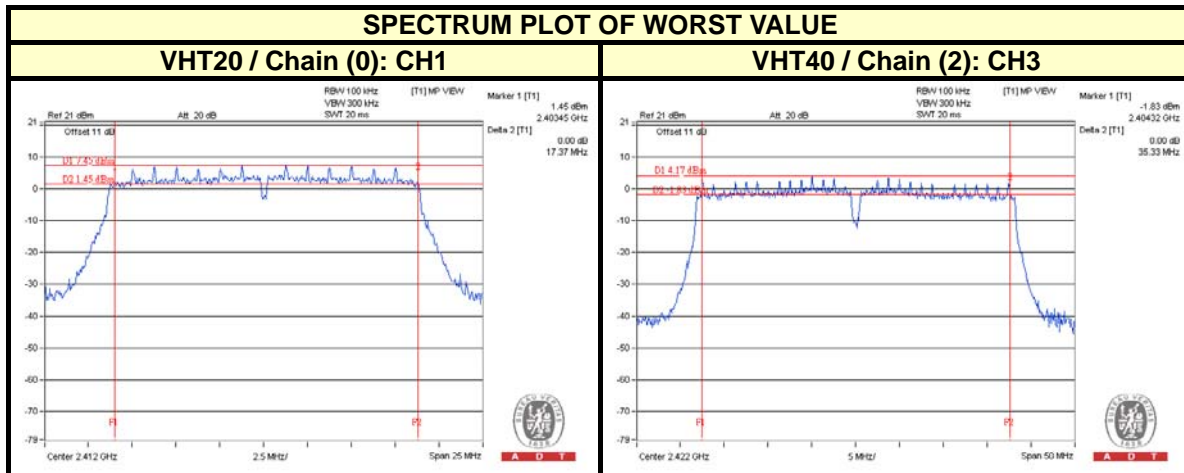



4.4 CONDUCTED OUTPUT POWER MEASUREMENT

4.4.1 LIMITS OF CONDUCTED OUTPUT POWER MEASUREMENT

For systems using digital modulation in the 2400–2483.5 MHz bands: 1 Watt (30dBm)

Per KDB 662911 D01 Multiple Transmitter Output Method of conducted output power measurement on IEEE 802.11 devices,

Array Gain = 0 dB (i.e., no array gain) for NANT \leq 4;

Array Gain = 0 dB (i.e., no array gain) for channel widths \geq 40 MHz for any NANT;

Array Gain = 5 log(NANT/NSS) dB or 3 dB, whichever is less for 20-MHz channel widths with NANT \geq 5.

For power measurements on all other devices: Array Gain = 10 log(NANT/NSS) dB.

4.4.2 TEST INSTRUMENTS

DESCRIPTION & MANUFACTURER	MODEL NO.	SERIAL NO.	CALIBRATED DATE	CALIBRATED UNTIL
Power meter Anritsu	ML2495A	1014008	Apr. 30, 2014	Apr. 29, 2015
Power sensor Anritsu	MA2411B	0917122	Apr. 30, 2014	Apr. 29, 2015

Note:

1. The calibration interval of the above test instruments is 12 months and the calibrations are traceable to NML/ROC and NIST/USA.
2. Tested date : Dec. 08, 2014

4.4.3 TEST PROCEDURES

The average power sensor was used on the output port of the EUT. A power meter was used to read the response of the average power sensor. Record the average power level.

4.4.4 DEVIATION FROM TEST STANDARD

No deviation.

4.4.5 TEST SETUP

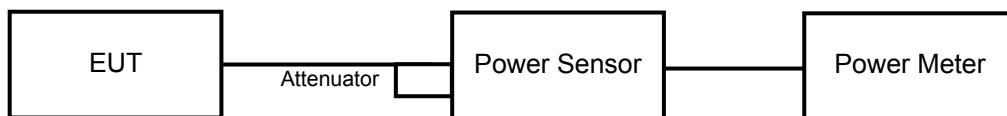

4.4.6 EUT OPERATING CONDITIONS

Same as Item 4.3.6

4.4.7 TEST RESULTS (MODE 1)

802.11b

CHANNEL	FREQUENCY (MHz)	AVERAGE POWER (dBm)			TOTAL POWER (mW)	TOTAL POWER (dBm)	LIMIT (dBm)	PASS / FAIL
		CHAIN 0	CHAIN 1	CHAIN 2				
1	2412	18.97	18.76	19.71	247.589	23.94	30	PASS
6	2437	21.06	21.47	22.29	437.359	26.41	30	PASS
11	2462	16.31	16.02	16.92	131.954	21.20	30	PASS

802.11g

CHANNEL	FREQUENCY (MHz)	AVERAGE POWER (dBm)			TOTAL POWER (mW)	TOTAL POWER (dBm)	LIMIT (dBm)	PASS / FAIL
		CHAIN 0	CHAIN 1	CHAIN 2				
1	2412	19.46	19.09	19.87	266.455	24.26	30	PASS
6	2437	23.38	23.12	24.09	679.335	28.32	30	PASS
11	2462	17.71	17.97	18.76	196.843	22.94	30	PASS

VHT20

CHANNEL	FREQUENCY (MHz)	AVERAGE POWER (dBm)			TOTAL POWER (mW)	TOTAL POWER (dBm)	LIMIT (dBm)	PASS / FAIL
		CHAIN 0	CHAIN 1	CHAIN 2				
1	2412	18.44	18.24	19.37	223.001	23.48	30	PASS
6	2437	22.65	22.56	23.43	584.672	27.67	30	PASS
11	2462	17.41	17.09	18.42	175.751	22.45	30	PASS

VHT40

CHANNEL	FREQUENCY (MHz)	AVERAGE POWER (dBm)			TOTAL POWER (mW)	TOTAL POWER (dBm)	LIMIT (dBm)	PASS / FAIL
		CHAIN 0	CHAIN 1	CHAIN 2				
3	2422	16.97	16.49	17.62	152.15	21.82	30	PASS
6	2437	18.02	17.44	18.46	188.996	22.76	30	PASS
9	2452	14.52	14.36	15.08	87.815	19.44	30	PASS

4.4.8 TEST RESULTS (MODE 2)

VHT20

CHANNEL	FREQUENCY (MHz)	AVERAGE POWER (dBm)			TOTAL POWER (mW)	TOTAL POWER (dBm)	LIMIT (dBm)	PASS / FAIL
		CHAIN 0	CHAIN 1	CHAIN 2				
1	2412	18.60	18.49	19.62	234.698	23.71	25.91	PASS
6	2437	20.58	20.68	21.46	371.197	25.70	25.91	PASS
11	2462	17.94	17.56	19.12	200.904	23.03	25.91	PASS

NOTE: Directional gain = $10 \log[(10^{G1/20} + 10^{G2/20} + 10^{G3/20})^2 / 3]$ = 10.09dBi > 6dBi , so the power limit shall be reduced to 30-(10.09-6) = 25.91dBm.

VHT40

CHANNEL	FREQUENCY (MHz)	AVERAGE POWER (dBm)			TOTAL POWER (mW)	TOTAL POWER (dBm)	LIMIT (dBm)	PASS / FAIL
		CHAIN 0	CHAIN 1	CHAIN 2				
3	2422	16.97	16.49	17.62	152.15	21.82	25.91	PASS
6	2437	18.02	17.44	18.46	188.996	22.76	25.91	PASS
9	2452	14.52	14.36	15.08	87.815	19.44	25.91	PASS

NOTE: Directional gain = $10 \log[(10^{G1/20} + 10^{G2/20} + 10^{G3/20})^2 / 3]$ = 10.09dBi > 6dBi , so the power limit shall be reduced to 30-(10.09-6) = 25.91dBm.



A D T

4.5 POWER SPECTRAL DENSITY MEASUREMENT

4.5.1 LIMITS OF POWER SPECTRAL DENSITY MEASUREMENT

The Maximum of Power Spectral Density Measurement is 8dBm.

4.5.2 TEST INSTRUMENTS

DESCRIPTION & MANUFACTURER	MODEL NO.	SERIAL NO.	CALIBRATED DATE	CALIBRATED UNTIL
SPECTRUM ANALYZER R&S	FSP 40	100060	May 08, 2014	May 07, 2015

Note:

1. The calibration interval of the above test instruments is 12 months and the calibrations are traceable to NML/ROC and NIST/USA.
2. Tested date : Dec. 08, 2014

4.5.3 TEST PROCEDURE

For 802.11b, 802.11g & VHT20 test:

1. Set the RBW = 10 kHz, VBW = 30 kHz, Detector = power averaging (RMS).
2. Ensure that the number of measurement points in the sweep $\geq 2 \times$ span/RBW
3. Sweep time = auto couple,
4. Employ trace averaging (RMS) mode over a minimum of 100 traces.
5. Use the peak marker function to determine the maximum amplitude level.

For VHT40 test:

1. Set the RBW = 10 kHz, VBW = 30 kHz, Detector = power averaging (RMS).
2. Ensure that the number of measurement points in the sweep $\geq 2 \times$ span/RBW
3. Sweep time = auto couple,
4. Employ trace averaging (RMS) mode over a minimum of 100 traces.
5. Use the peak marker function to determine the maximum amplitude level.
6. Add $10 \log (1/x)$, where x is the duty cycle, to the measured PSD to compute the average PSD during the actual transmission time.

4.5.4 DEVIATION FROM TEST STANDARD

No deviation

4.5.5 TEST SETUP

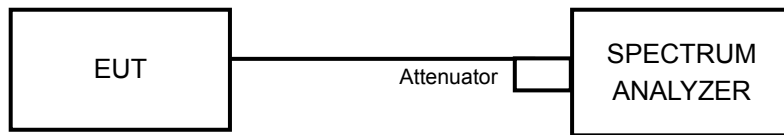

4.5.6 EUT OPERATING CONDITION

Same as Item 4.3.6



4.5.7 TEST RESULTS (MODE 1)

802.11b

TX CHAIN	CHANNEL	FREQUENCY (MHz)	PSD (dBm)	10 log (N=3) dB	TOTAL PSD (dBm)	LIMIT (dBm)	PASS /FAIL
0	1	2412	-9.17	4.77	-4.40	3.91	PASS
	6	2437	-7.25	4.77	-2.48	3.91	PASS
	11	2462	-12.12	4.77	-7.35	3.91	PASS
1	1	2412	-9.68	4.77	-4.91	3.91	PASS
	6	2437	-7.14	4.77	-2.37	3.91	PASS
	11	2462	-12.70	4.77	-7.93	3.91	PASS
2	1	2412	-8.63	4.77	-3.86	3.91	PASS
	6	2437	-5.91	4.77	-1.14	3.91	PASS
	11	2462	-11.04	4.77	-6.27	3.91	PASS

NOTE: 1. Directional gain = $10 \log[(10^{G1/20} + 10^{G2/20} + 10^{G3/20})^2 / 3] = 10.09\text{dBi} > 6\text{dBi}$, so the power density limit shall be reduced to $8-(10.09-6) = 3.91\text{dBm}$.

802.11g

TX CHAIN	CHANNEL	FREQUENCY (MHz)	PSD (dBm)	10 log (N=3) dB	TOTAL PSD (dBm)	LIMIT (dBm)	PASS /FAIL
0	1	2412	-10.85	4.77	-6.08	3.91	PASS
	6	2437	-6.31	4.77	-1.54	3.91	PASS
	11	2462	-11.88	4.77	-7.11	3.91	PASS
1	1	2412	-10.65	4.77	-5.88	3.91	PASS
	6	2437	-5.25	4.77	-0.48	3.91	PASS
	11	2462	-13.28	4.77	-8.51	3.91	PASS
2	1	2412	-9.87	4.77	-5.10	3.91	PASS
	6	2437	-5.76	4.77	-0.99	3.91	PASS
	11	2462	-10.83	4.77	-6.06	3.91	PASS

NOTE: 1. Directional gain = $10 \log[(10^{G1/20} + 10^{G2/20} + 10^{G3/20})^2 / 3] = 10.09\text{dBi} > 6\text{dBi}$, so the power density limit shall be reduced to $8-(10.09-6) = 3.91\text{dBm}$.



A D T

VHT20

TX CHAIN	CHANNEL	FREQUENCY (MHz)	PSD (dBm)	10 log (N=3) dB	TOTAL PSD (dBm)	LIMIT (dBm)	PASS /FAIL
0	1	2412	-12.33	4.77	-7.56	3.91	PASS
	6	2437	-8.89	4.77	-4.12	3.91	PASS
	11	2462	-13.98	4.77	-9.21	3.91	PASS
1	1	2412	-11.63	4.77	-6.86	3.91	PASS
	6	2437	-7.35	4.77	-2.58	3.91	PASS
	11	2462	-13.49	4.77	-8.72	3.91	PASS
2	1	2412	-11.85	4.77	-7.08	3.91	PASS
	6	2437	-7.87	4.77	-3.10	3.91	PASS
	11	2462	-12.45	4.77	-7.68	3.91	PASS

NOTE: 1. Directional gain = $10 \log[(10^{G1/20} + 10^{G2/20} + 10^{G3/20})^2 / 3] = 10.09\text{dBi} > 6\text{dBi}$, so the power density limit shall be reduced to $8-(10.09-6) = 3.91\text{dBm}$.

VHT40

TX CHAIN	CHANNEL	FREQ. (MHz)	PSD W/O DUTY FACTOR (dBm)	10 log (N=3) dB	DUTY FACTOR (dB)	TOTAL PSD WITH DUTY FACTOR (dBm)	LIMIT (dBm)	PASS /FAIL
0	3	2422	-16.63	4.77	0.09	-11.77	3.91	PASS
	6	2437	-16.19	4.77	0.09	-11.33	3.91	PASS
	9	2452	-18.77	4.77	0.09	-13.91	3.91	PASS
1	3	2422	-15.52	4.77	0.09	-10.66	3.91	PASS
	6	2437	-14.07	4.77	0.09	-9.21	3.91	PASS
	9	2452	-17.06	4.77	0.09	-12.20	3.91	PASS
2	3	2422	-15.19	4.77	0.09	-10.33	3.91	PASS
	6	2437	-14.93	4.77	0.09	-10.07	3.91	PASS
	9	2452	-17.87	4.77	0.09	-13.01	3.91	PASS

NOTE: 1. Directional gain = $10 \log[(10^{G1/20} + 10^{G2/20} + 10^{G3/20})^2 / 3] = 10.09\text{dBi} > 6\text{dBi}$, so the power density limit shall be reduced to $8-(10.09-6) = 3.91\text{dBm}$.

2. Refer to section 3.4 for duty cycle spectrum plot.



A D T

SPECTRUM PLOT OF WORST VALUE

802.11b / Chain (2): CH6

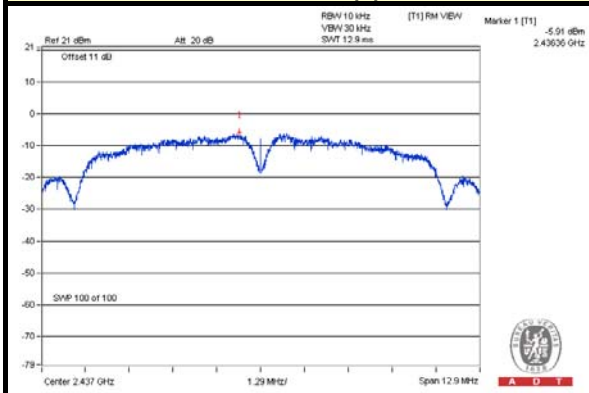

802.11g / Chain (1): CH1

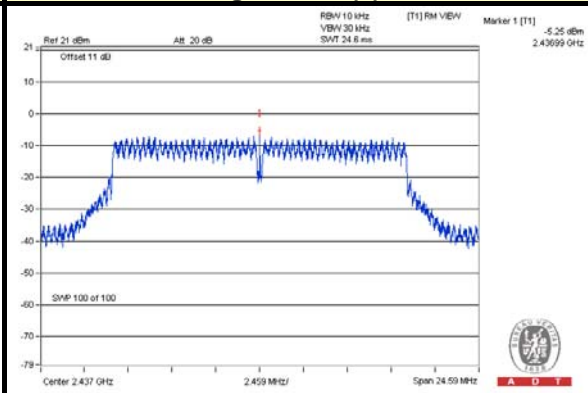

VHT20 / Chain (1): CH6

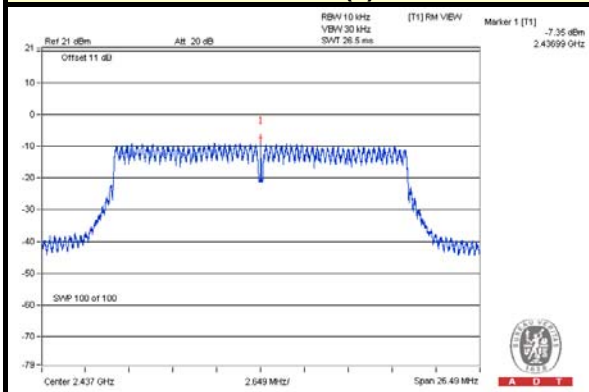

VHT40 / Chain (1): CH6

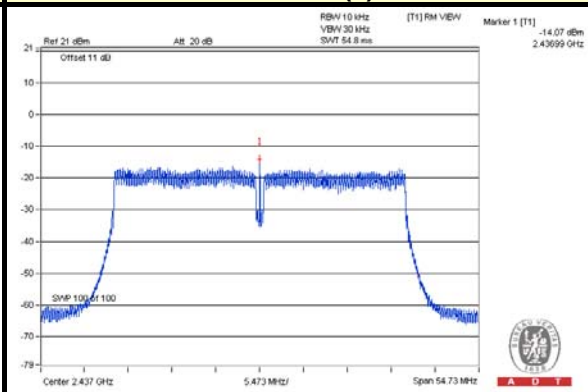



4.5.8 TEST RESULTS (MODE 2)

VHT20

TX CHAIN	CHANNEL	FREQUENCY (MHz)	PSD (dBm)	10 log (N=3) dB	TOTAL PSD (dBm)	LIMIT (dBm)	PASS /FAIL
0	1	2412	-11.77	4.77	-7.00	3.91	PASS
	6	2437	-10.26	4.77	-5.49	3.91	PASS
	11	2462	-12.70	4.77	-7.93	3.91	PASS
1	1	2412	-11.95	4.77	-7.18	3.91	PASS
	6	2437	-9.52	4.77	-4.75	3.91	PASS
	11	2462	-12.70	4.77	-7.93	3.91	PASS
2	1	2412	-11.71	4.77	-6.94	3.91	PASS
	6	2437	-10.43	4.77	-5.66	3.91	PASS
	11	2462	-12.88	4.77	-8.11	3.91	PASS

NOTE: 1. Directional gain = $10 \log[(10^{G1/20} + 10^{G2/20} + 10^{G3/20})^2 / 3] = 10.09\text{dBi} > 6\text{dBi}$, so the power density limit shall be reduced to $8-(10.09-6) = 3.91\text{dBm}$.

VHT40

TX CHAIN	CHANNEL	FREQ. (MHz)	PSD W/O DUTY FACTOR (dBm)	10 log (N=3) dB	DUTY FACTOR (dB)	TOTAL PSD WITH DUTY FACTOR (dBm)	LIMIT (dBm)	PASS /FAIL
0	3	2422	-15.93	4.77	0.09	-11.07	3.91	PASS
	6	2437	-15.17	4.77	0.09	-10.31	3.91	PASS
	9	2452	-18.13	4.77	0.09	-13.27	3.91	PASS
1	3	2422	-15.03	4.77	0.09	-10.17	3.91	PASS
	6	2437	-14.22	4.77	0.09	-9.36	3.91	PASS
	9	2452	-17.92	4.77	0.09	-13.06	3.91	PASS
2	3	2422	-15.89	4.77	0.09	-11.03	3.91	PASS
	6	2437	-15.62	4.77	0.09	-10.76	3.91	PASS
	9	2452	-18.79	4.77	0.09	-13.93	3.91	PASS

NOTE: 1. Directional gain = $10 \log[(10^{G1/20} + 10^{G2/20} + 10^{G3/20})^2 / 3] = 10.09\text{dBi} > 6\text{dBi}$, so the power density limit shall be reduced to $8-(10.09-6) = 3.91\text{dBm}$.

2. Refer to section 3.4 for duty cycle spectrum plot.



A D T

SPECTRUM PLOT OF WORST VALUE

VHT20 / Chain (1): CH6

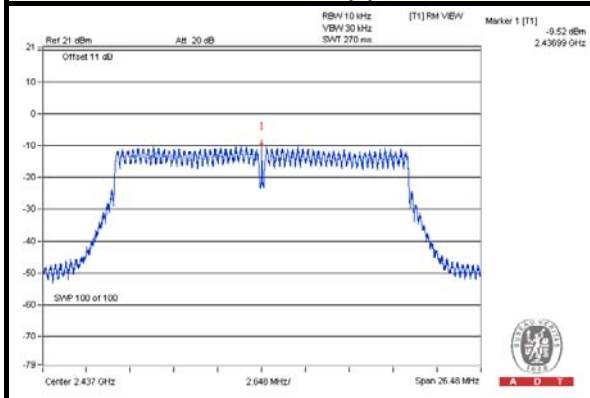

VHT40 / Chain (1): CH6

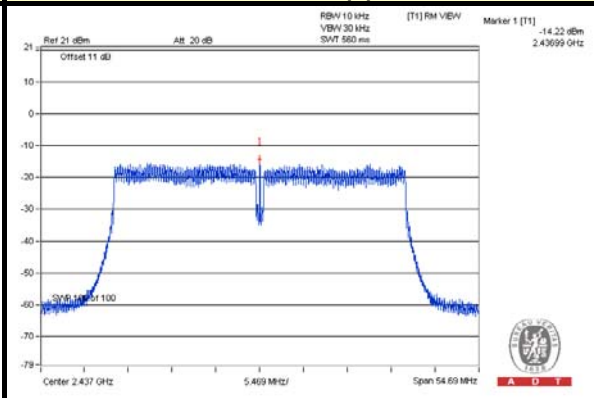



A D T

4.6 CONDUCTED OUT-BAND EMISSION MEASUREMENT

4.6.1 LIMITS OF CONDUCTED OUT-BAND EMISSION MEASUREMENT

Below 30dB of the highest emission level of operating band (in 100kHz Resolution Bandwidth).

4.6.2 TEST INSTRUMENTS

DESCRIPTION & MANUFACTURER	MODEL NO.	SERIAL NO.	CALIBRATED DATE	CALIBRATED UNTIL
SPECTRUM ANALYZER R&S	FSP 40	100060	May 08, 2014	May 07, 2015

Note:

1. The calibration interval of the above test instruments is 12 months and the calibrations are traceable to NML/ROC and NIST/USA.
2. Tested date : Dec. 08, 2014

4.6.3 TEST PROCEDURE

Measurement Procedure - Reference Level

1. Set the RBW = 100 kHz.
2. Set the VBW \geq 300 kHz.
3. Detector = peak.
4. Sweep time = auto couple.
5. Trace mode = max hold.
6. Allow trace to fully stabilize.
7. Use the peak marker function to determine the maximum power level in any 100 kHz band segment within the fundamental EBW.

Measurement Procedure –Unwanted Emission Level

1. Set RBW = 100 kHz.
2. Set VBW \geq 300 kHz.
3. Detector = peak.
4. Sweep = auto couple.
5. Trace Mode = max hold.
6. Allow trace to fully stabilize.
7. Use the peak marker function to determine the maximum amplitude level.

4.6.4 DEVIATION FROM TEST STANDARD

No deviation

4.6.5 TEST SETUP

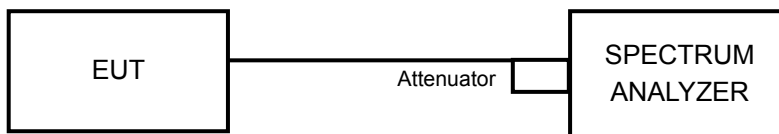

4.6.6 EUT OPERATING CONDITION

Same as Item 4.3.6

4.6.7 TEST RESULTS (MODE 1)

The spectrum plots are attached on the following pages. D1 line indicates the highest level, and D2 line indicates the 30dB offset below D1. It shows compliance with the requirement.

802.11b

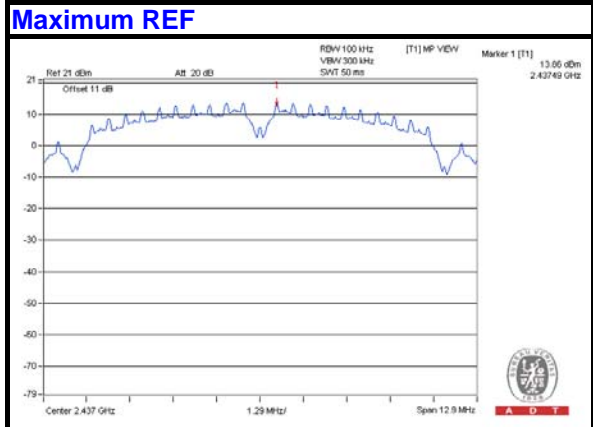

Chain(0)

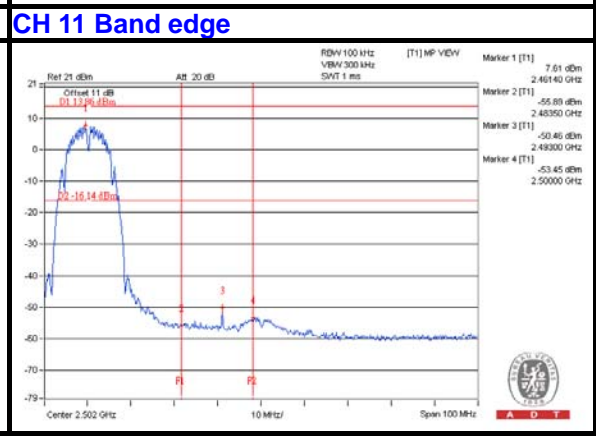
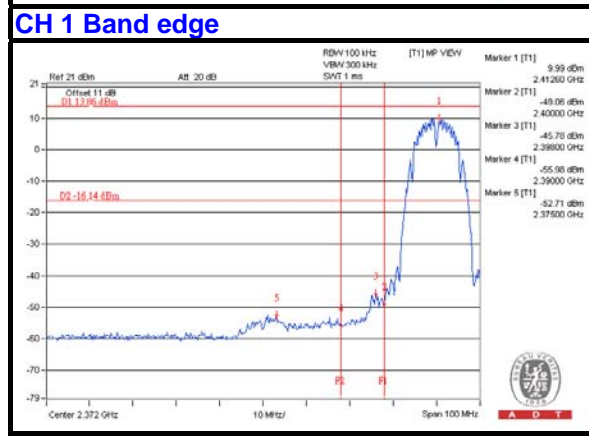
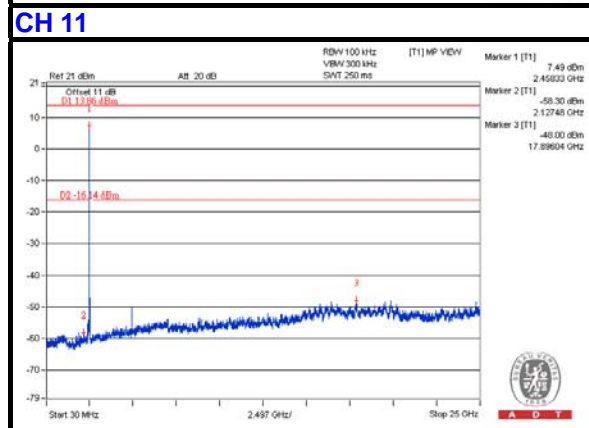
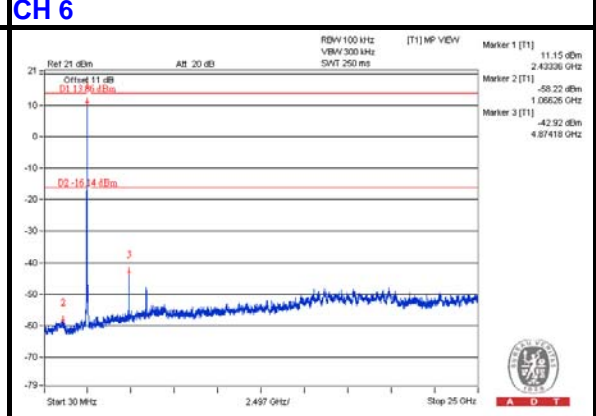
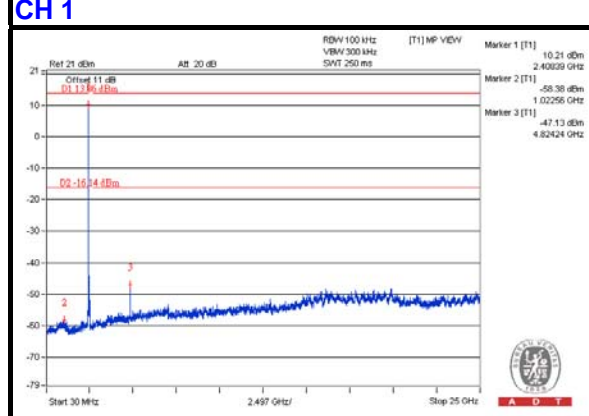



A D T

Chain(1)

CH 1

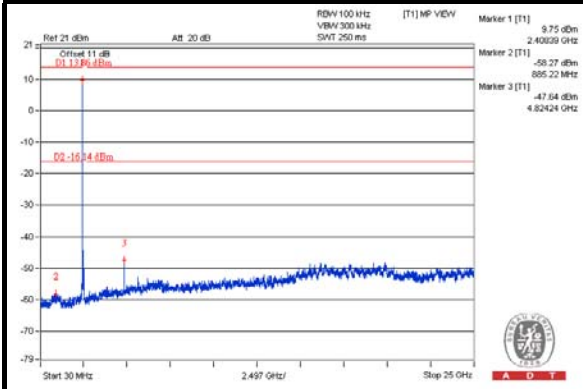

CH 6

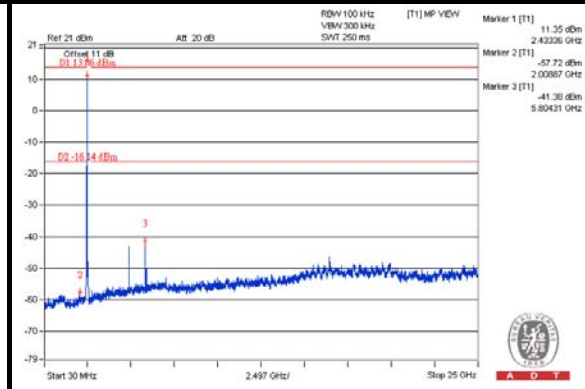

CH 11

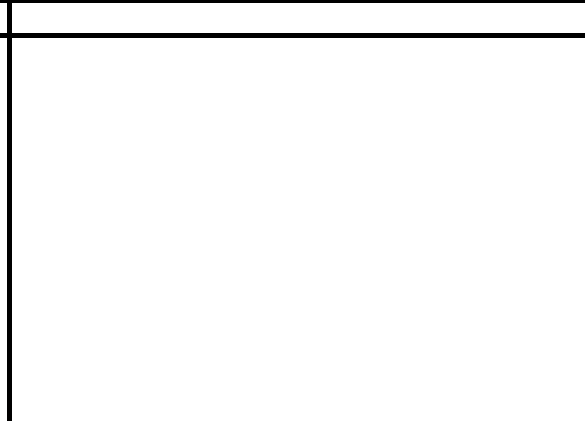
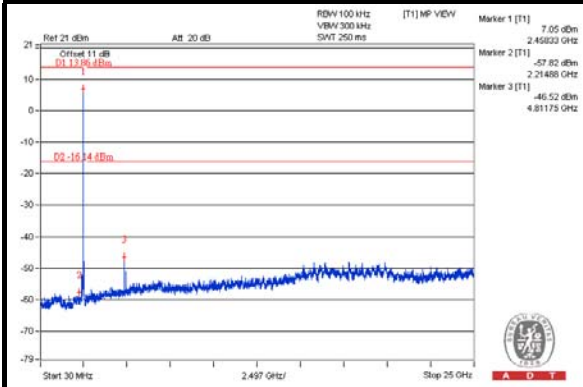

CH 1 Band edge

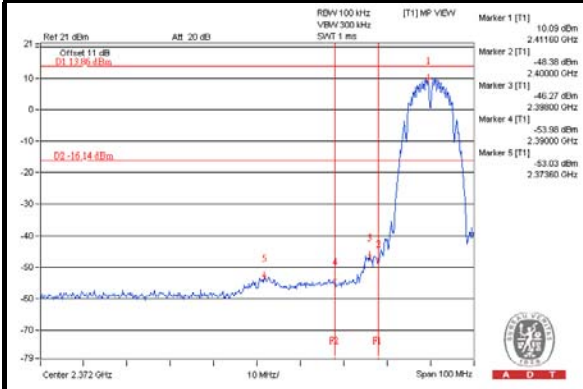

CH 11 Band edge

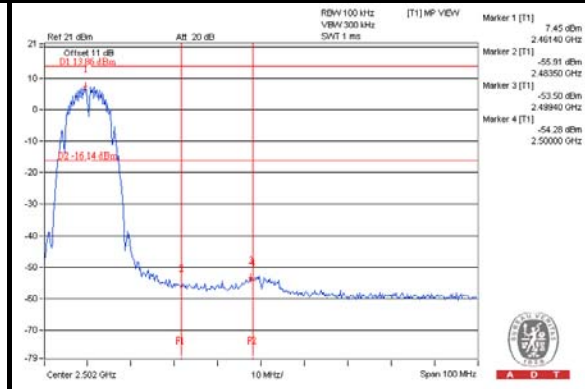



A D T

Chain(2)

CH 1

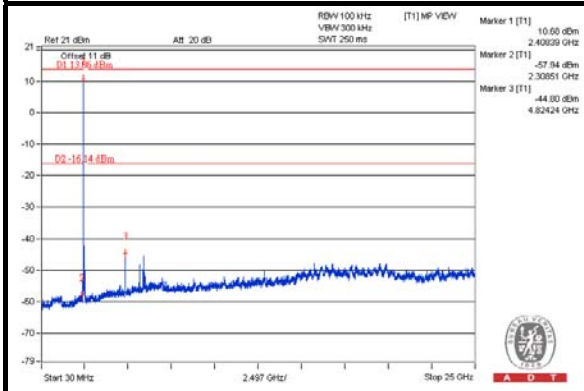

CH 6

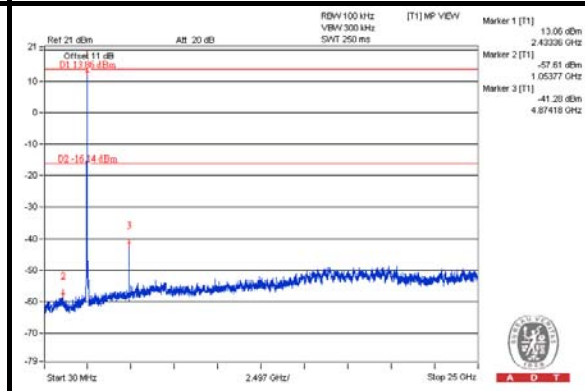

CH 11

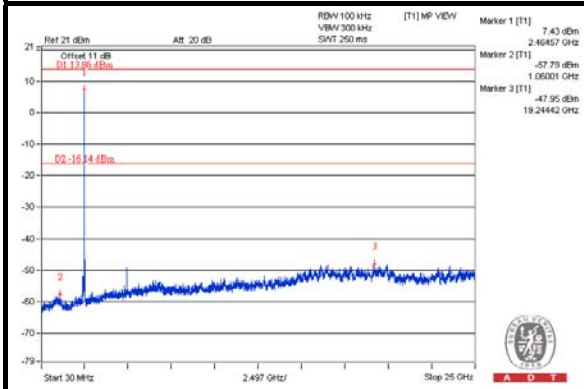

CH 1 Band edge

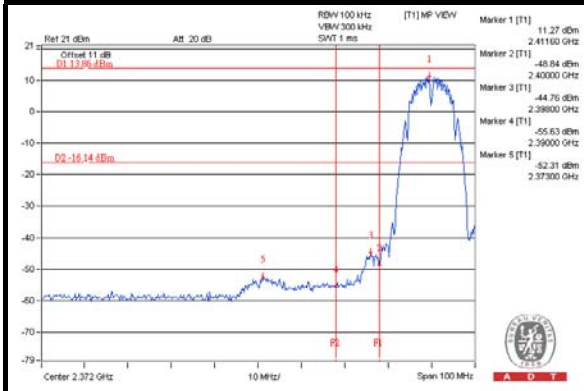

CH 11 Band edge

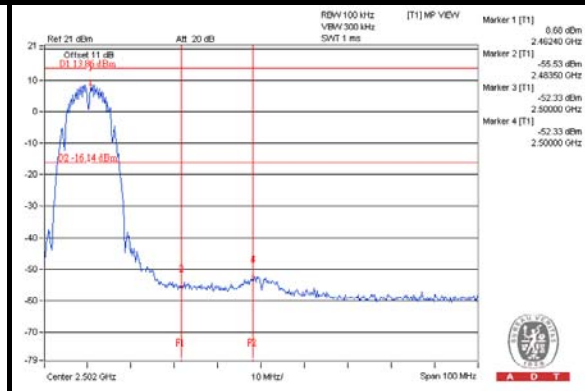

802.11g

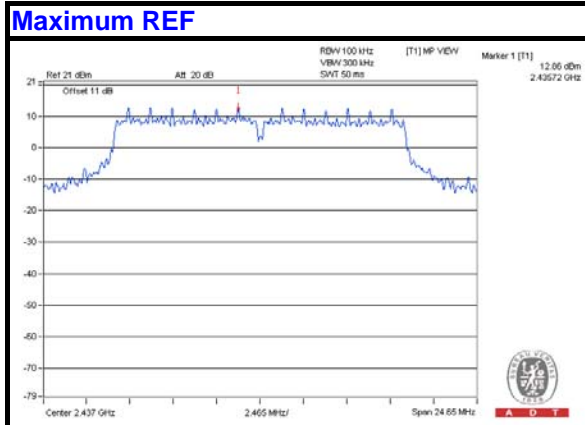

Chain(0)

CH 1

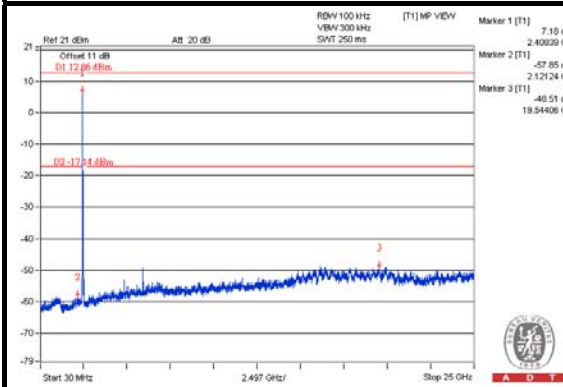

CH 6

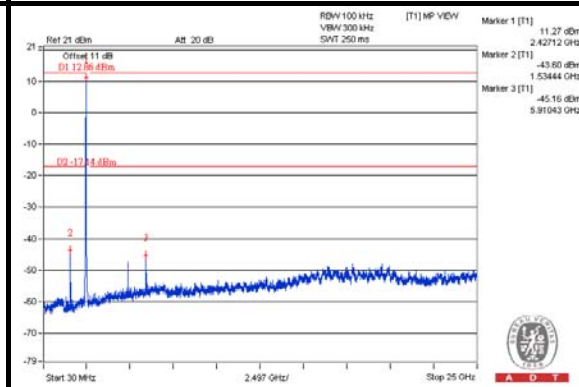

CH 11

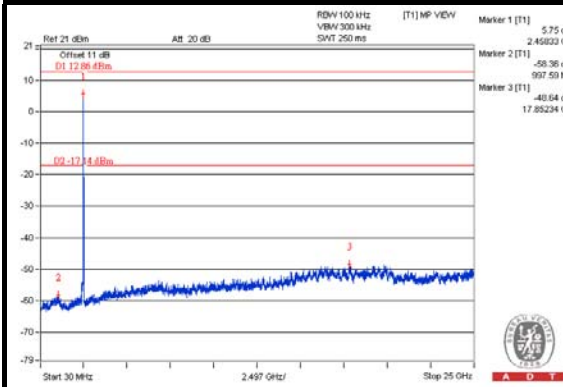

CH 1 Band edge

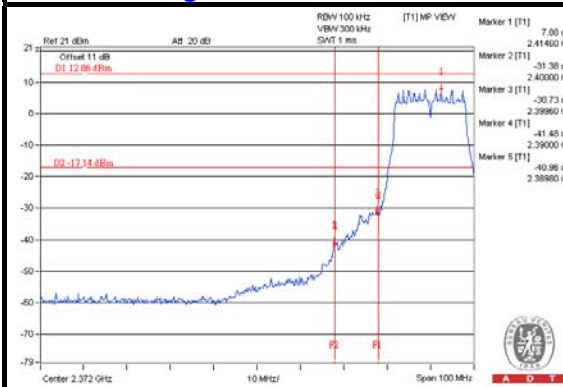

CH 11 Band edge

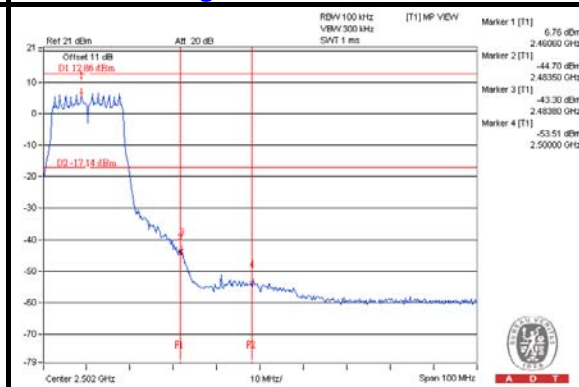



A D T

Chain(1)

CH 1

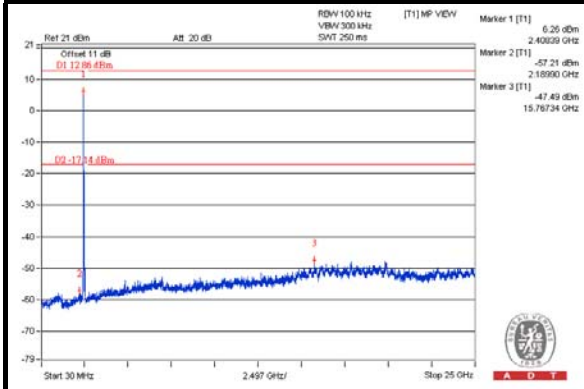

CH 6

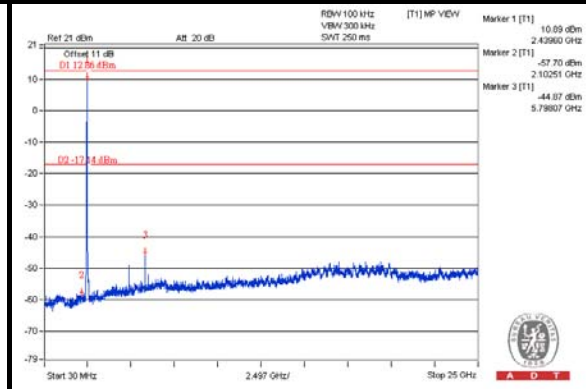

CH 11

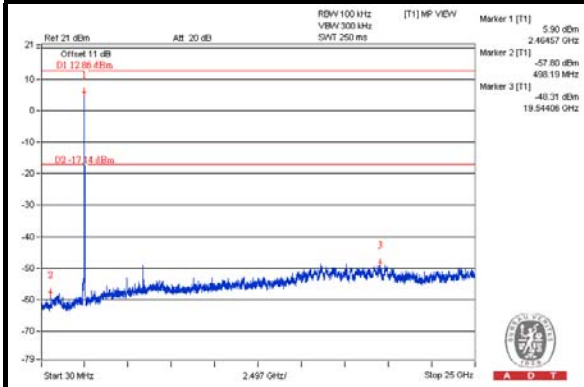

CH 1 Band edge

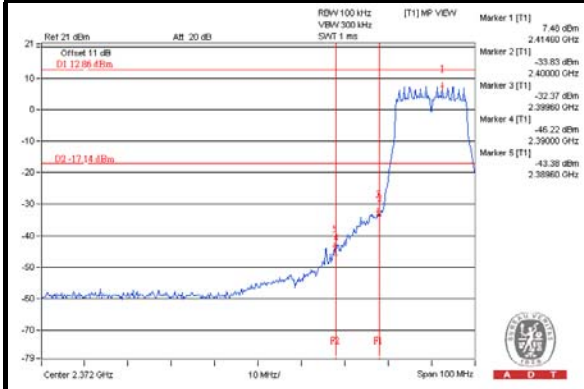

CH 11 Band edge

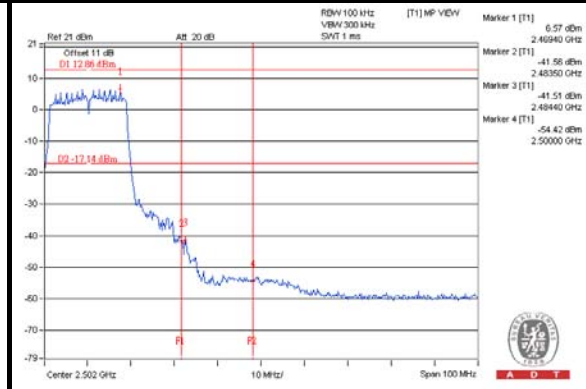



A D T

Chain(2)

CH 1

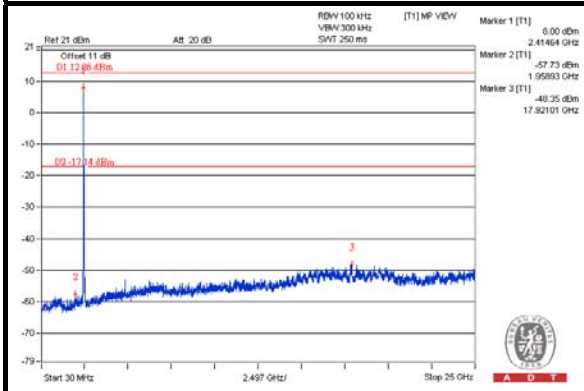

CH 6

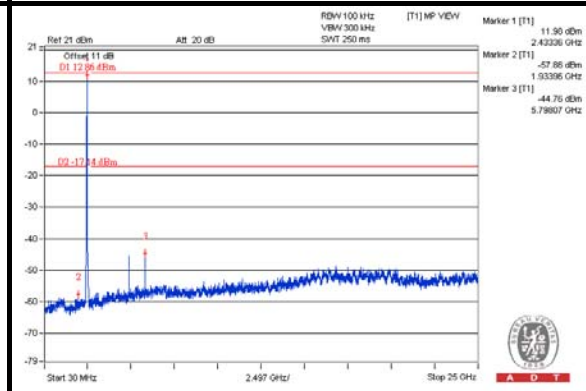

CH 11

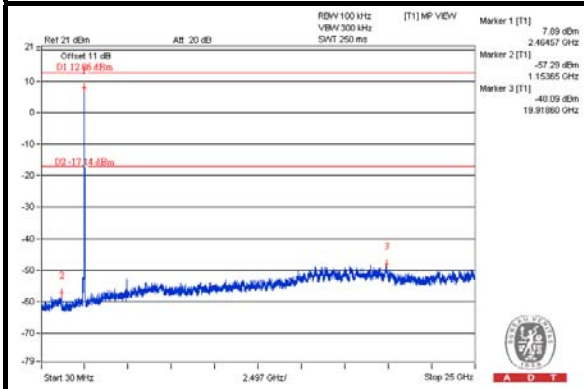

CH 1 Band edge

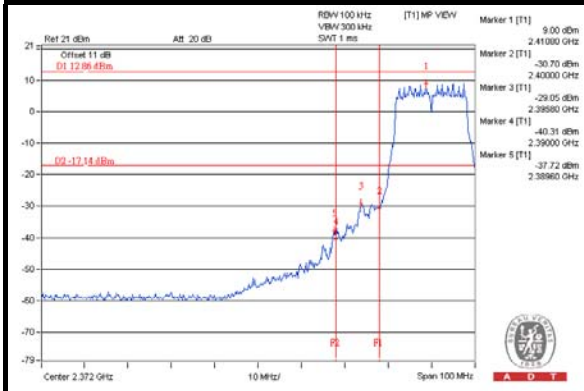

CH 11 Band edge

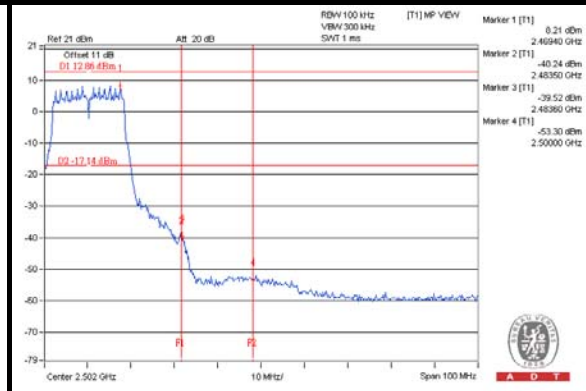



A D T

VHT20

Maximum REF

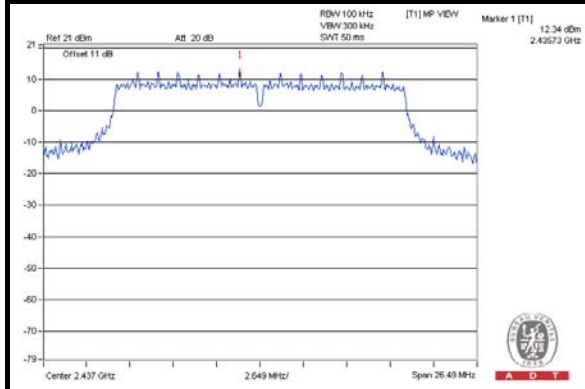

Chain(0)

CH 1

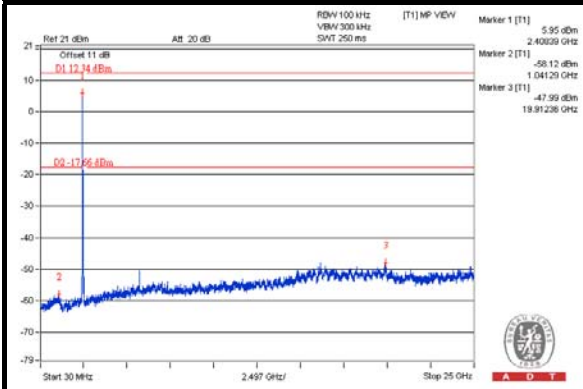

CH 6

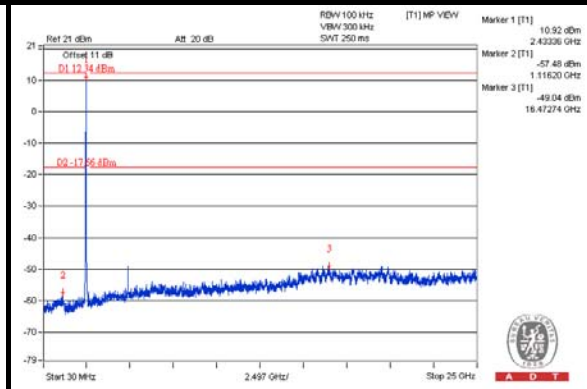

CH 11

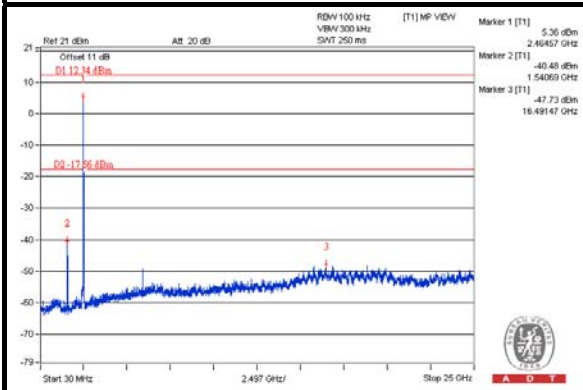

CH 1 Band edge

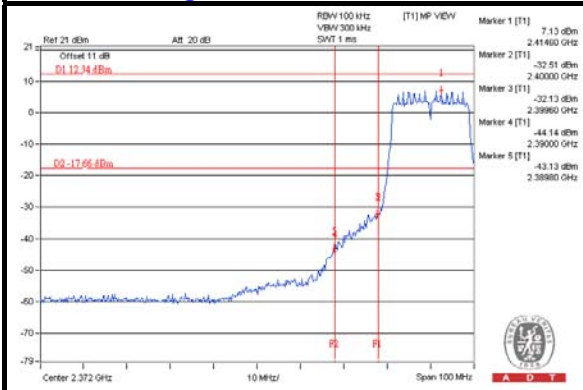

CH 11 Band edge

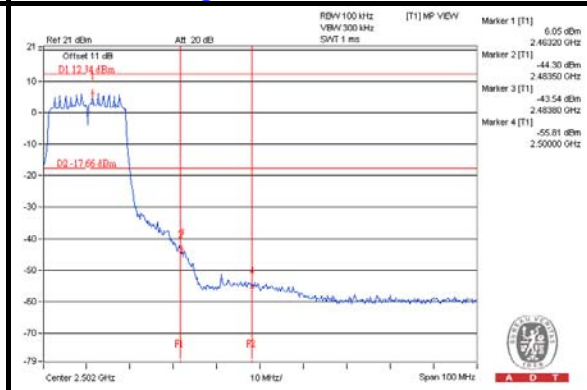



A D T

Chain(1)

CH 1

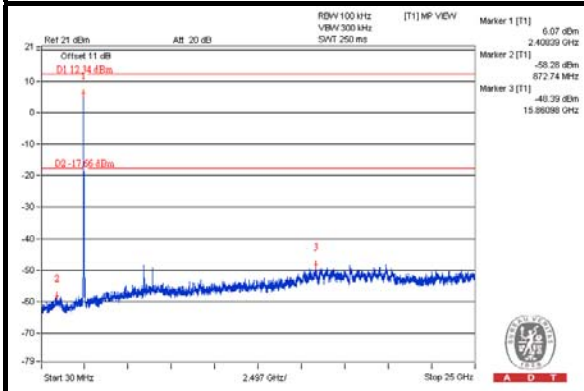

CH 6

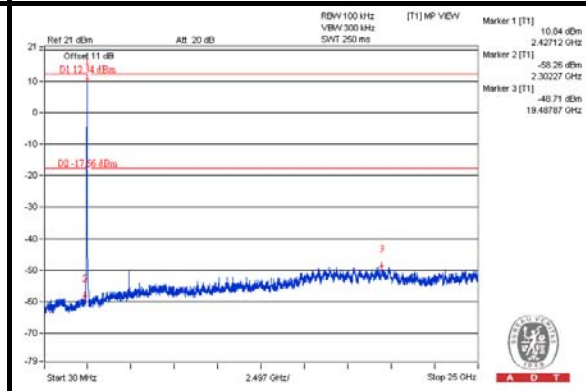

CH 11

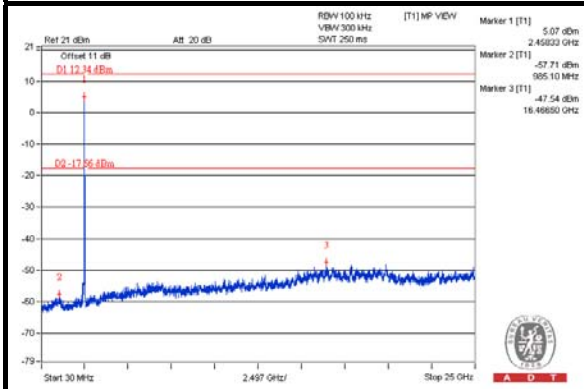

CH 1 Band edge

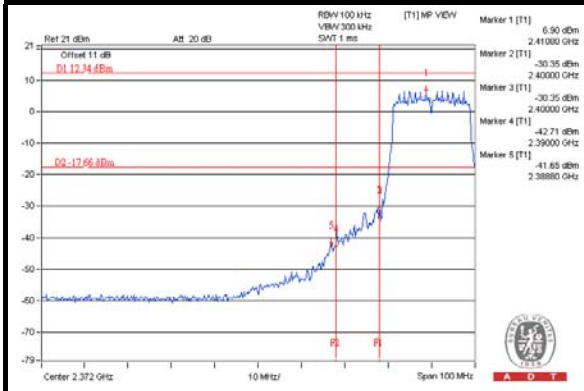

CH 11 Band edge

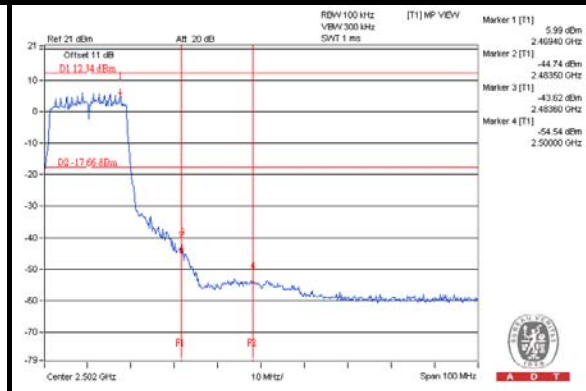



A D T

Chain(2)

CH 1

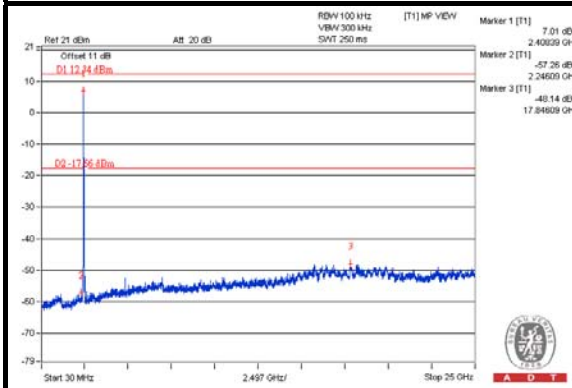

CH 6

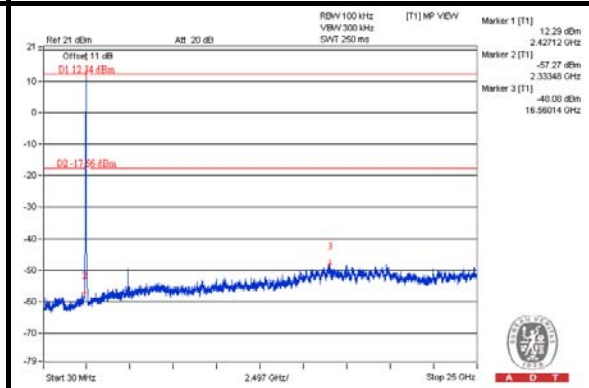

CH 11

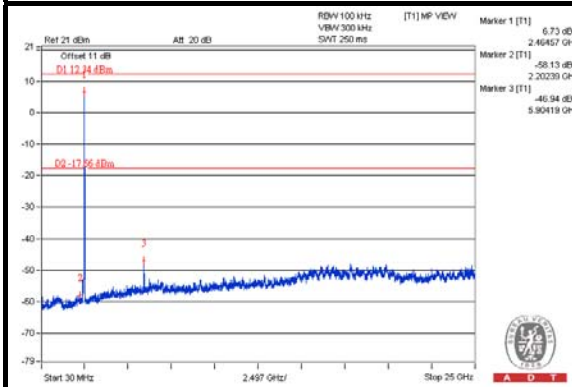

CH 1 Band edge

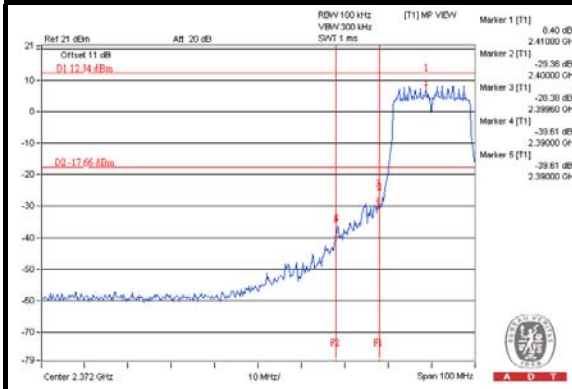

CH 11 Band edge

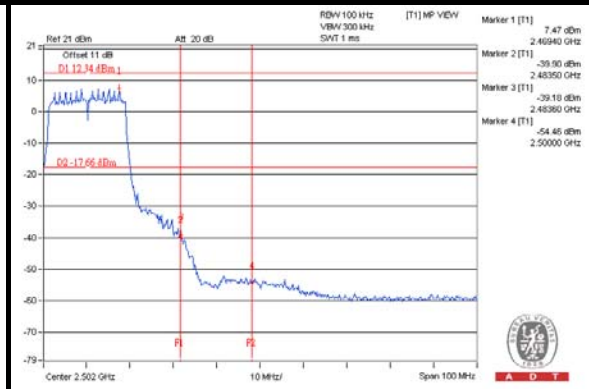



A D T

VHT40

Maximum REF

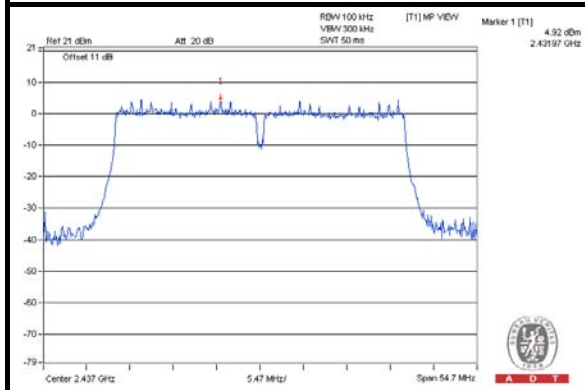

Chain(0)

CH 3

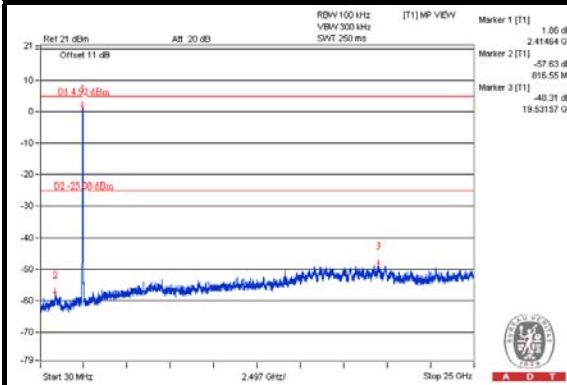

CH 6

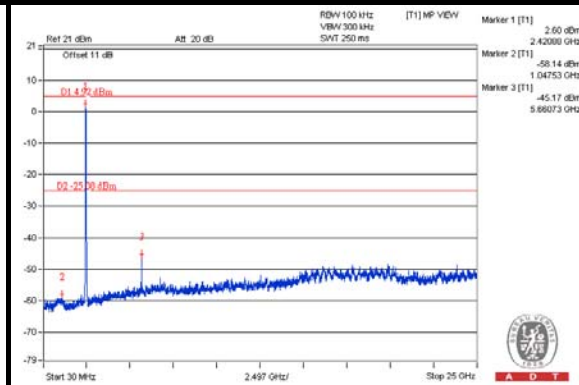

CH 9

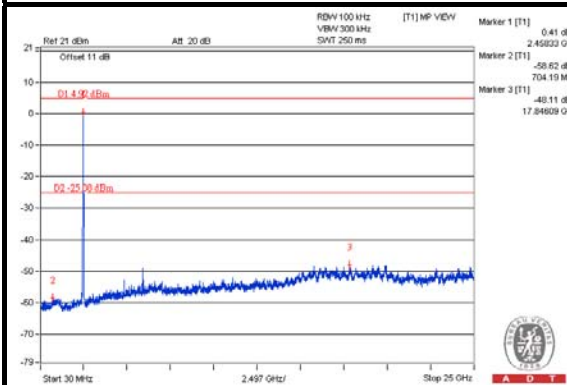

CH 3 Band edge

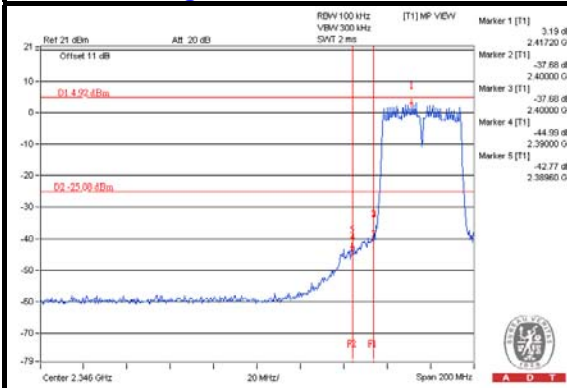

CH 9 Band edge

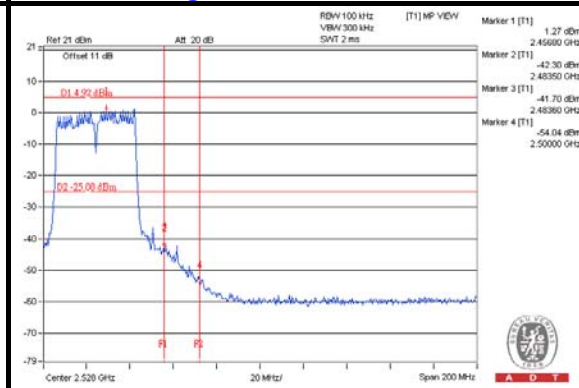



A D T

Chain(1)

CH 3

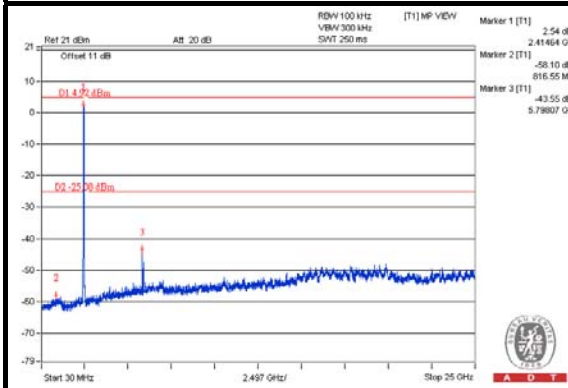

CH 6

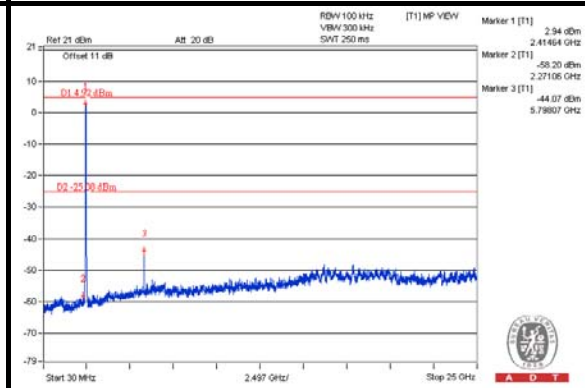

CH 9

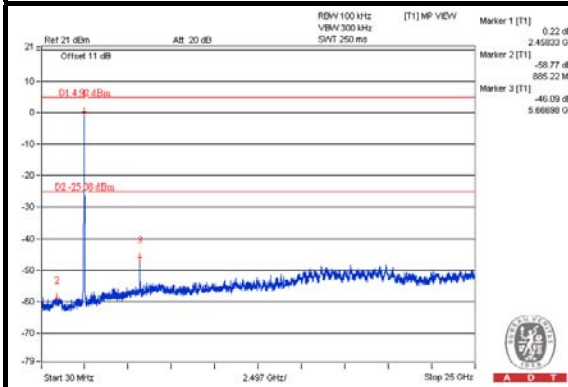

CH 3 Band edge

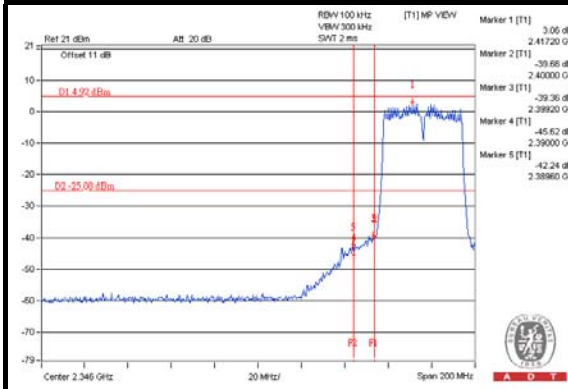

CH 9 Band edge

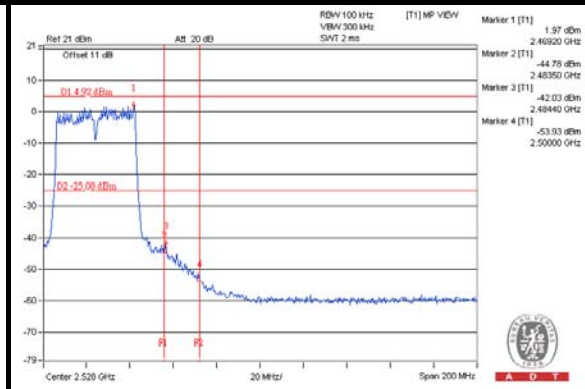



A D T

Chain(2)

CH 3

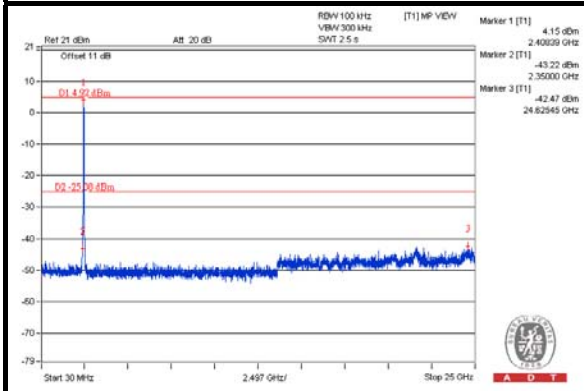

CH 6

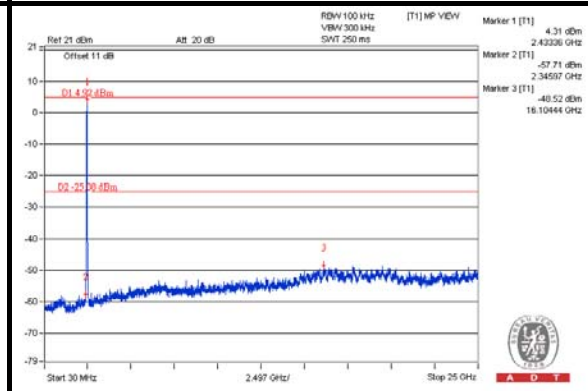

CH 9

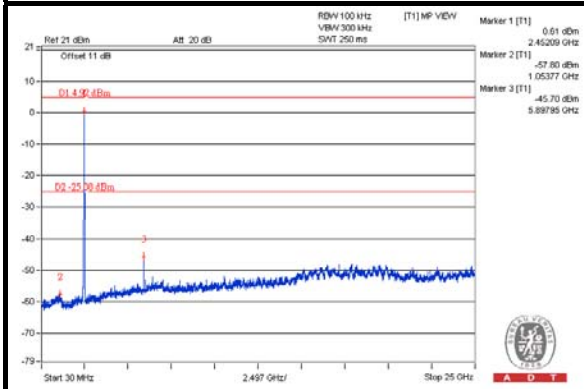

CH 3 Band edge

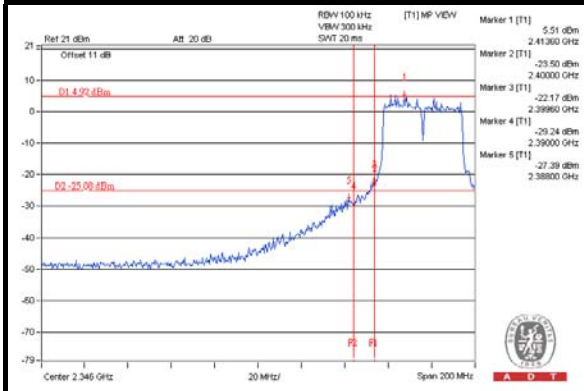

CH 9 Band edge

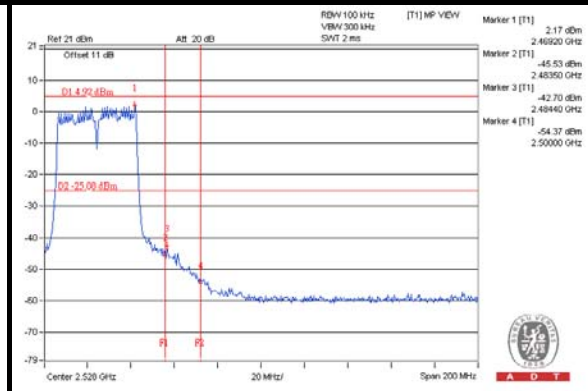



A D T

4.6.8 TEST RESULTS (MODE 2)

The spectrum plots are attached on the following pages. D1 line indicates the highest level, and D2 line indicates the 30dB offset below D1. It shows compliance with the requirement.



A D T

VHT20

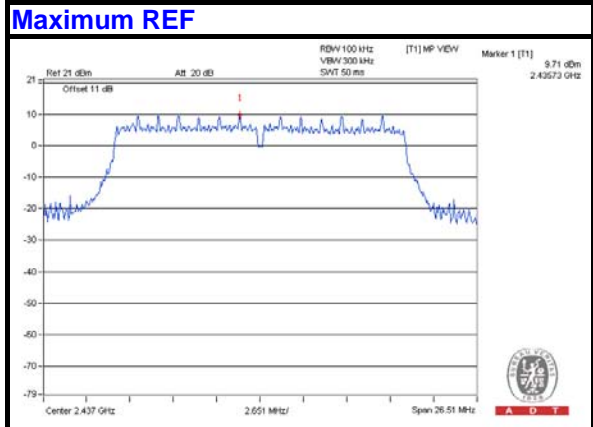

Chain(0)

CH 1

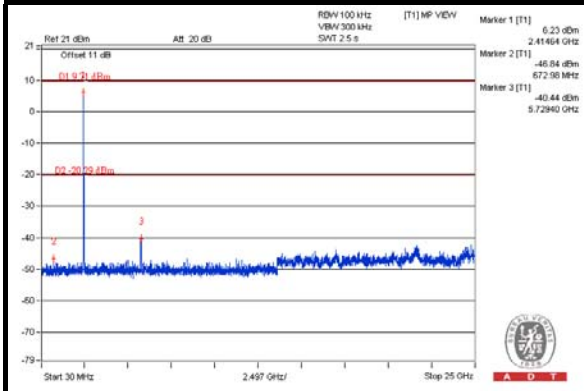

CH 6

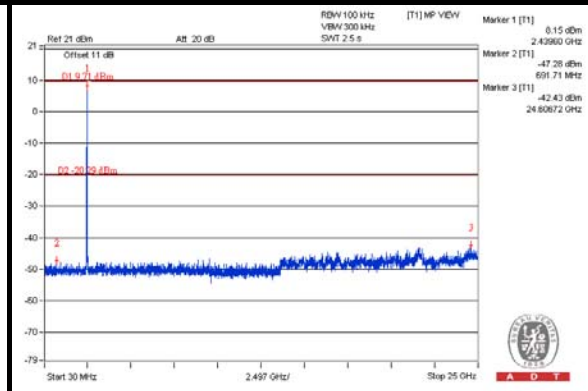

CH 11

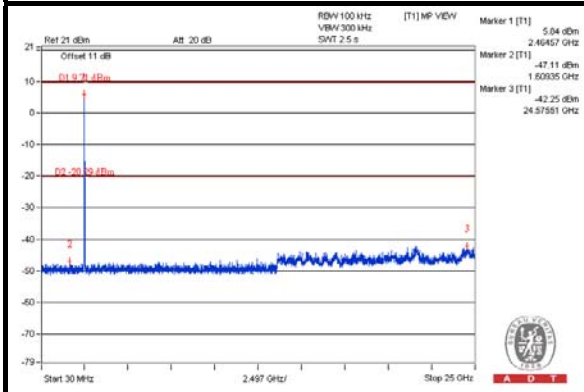

CH 1 Band edge

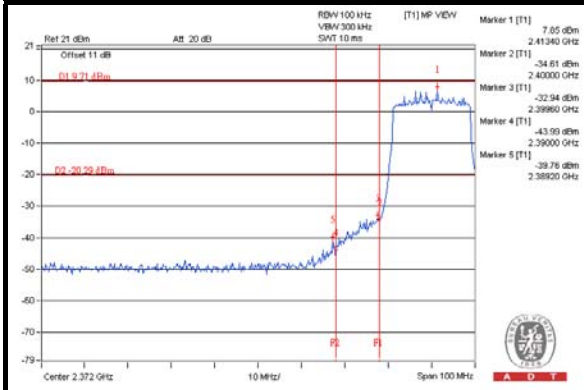

CH 11 Band edge

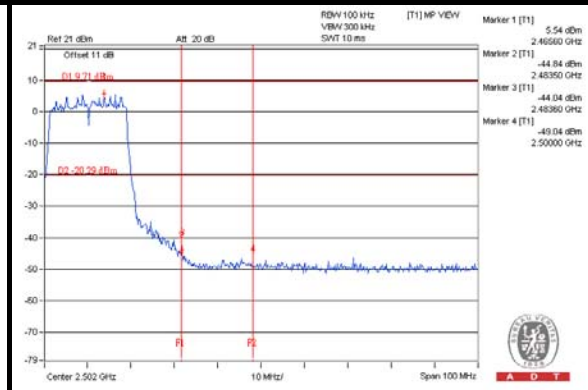



A D T

Chain(1)

CH 1

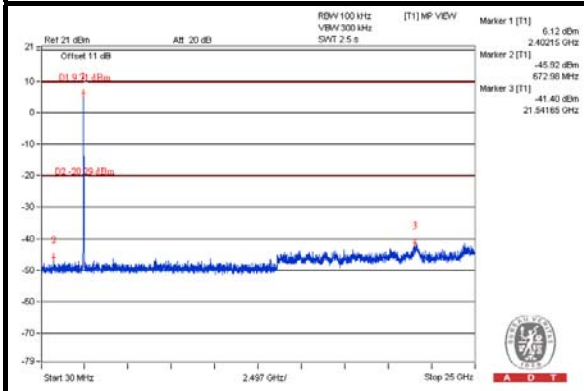

CH 6

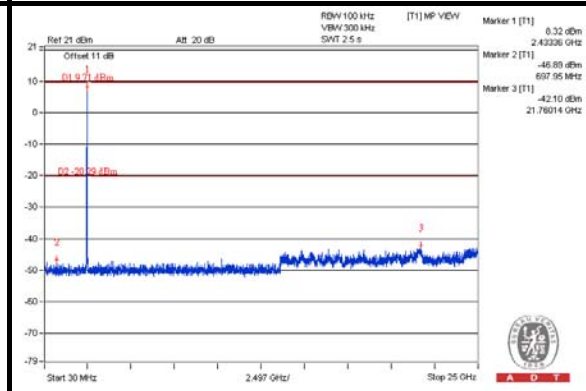

CH 11

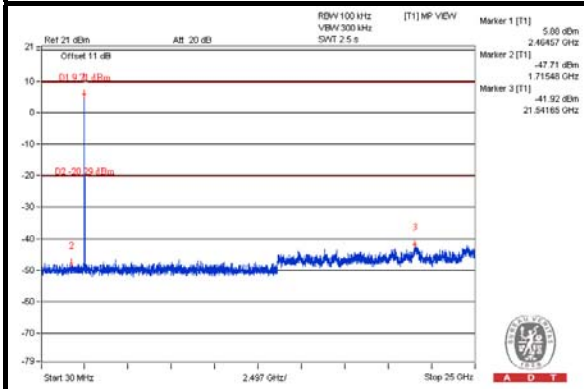

CH 1 Band edge

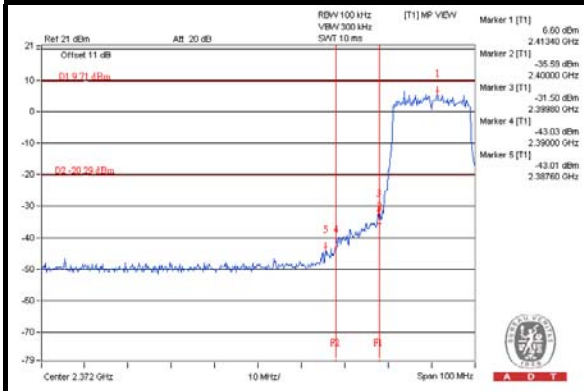

CH 11 Band edge

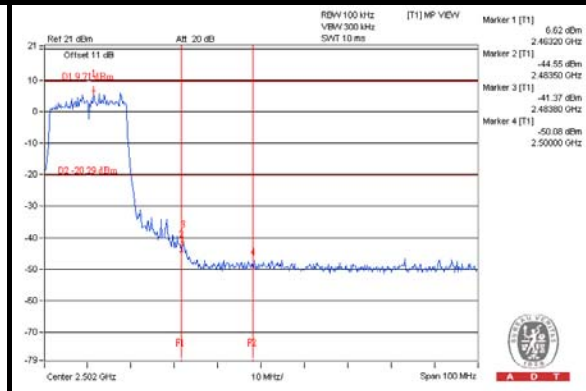



A D T

Chain(2)

CH 1

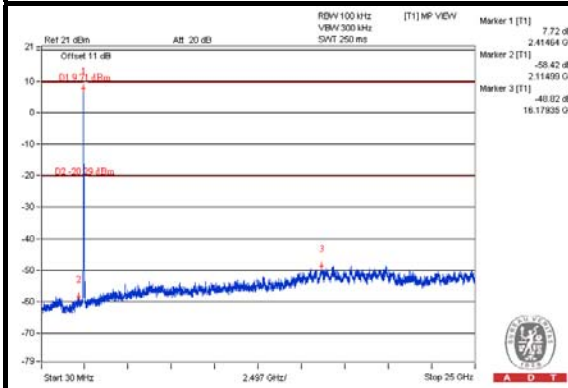

CH 6

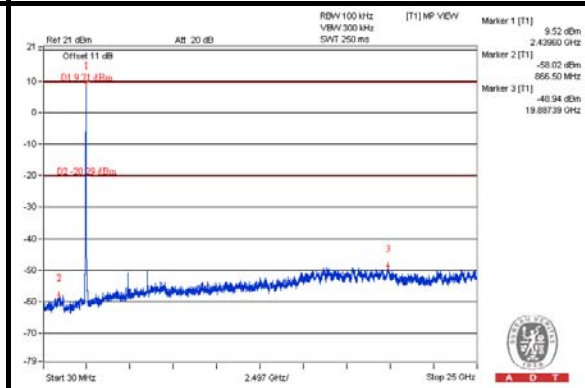

CH 11

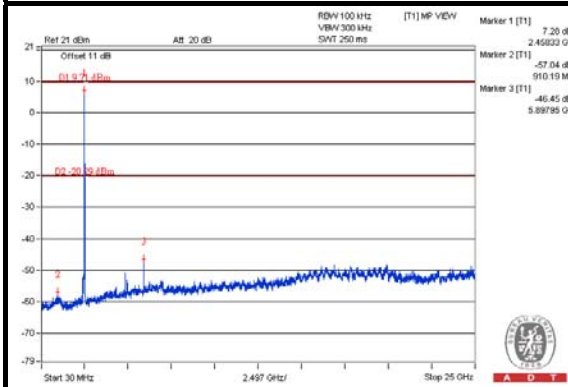

CH 1 Band edge

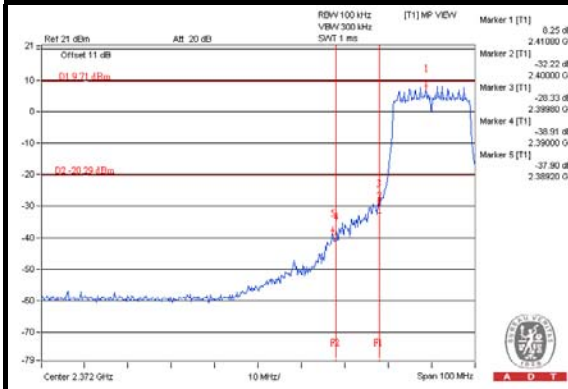

CH 11 Band edge

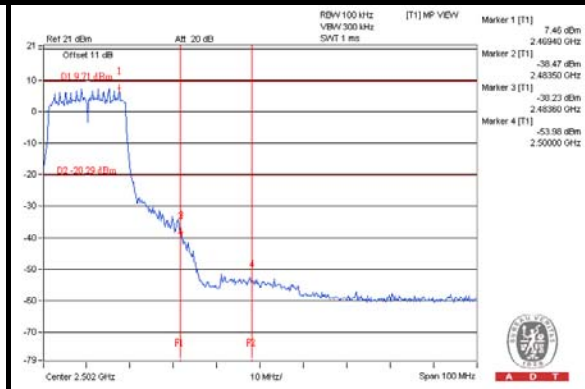

VHT40

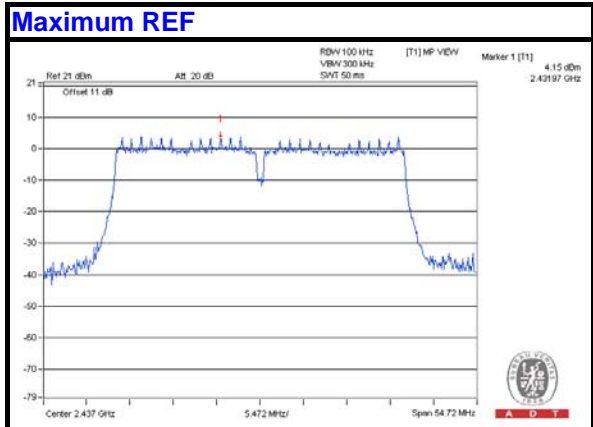

Chain(0)

CH 3

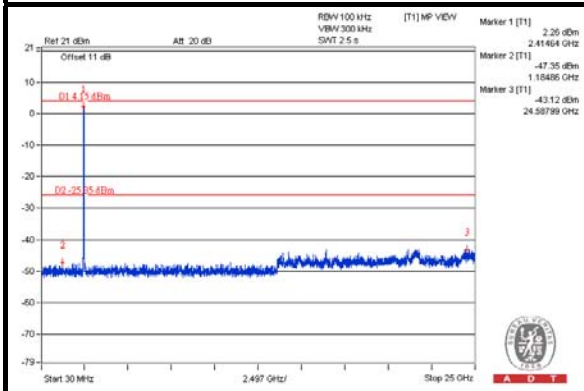

CH 6

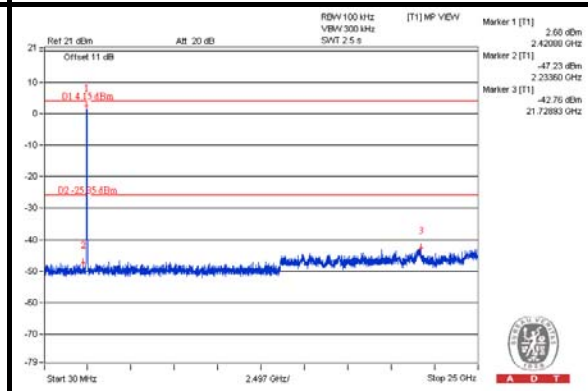

CH 9

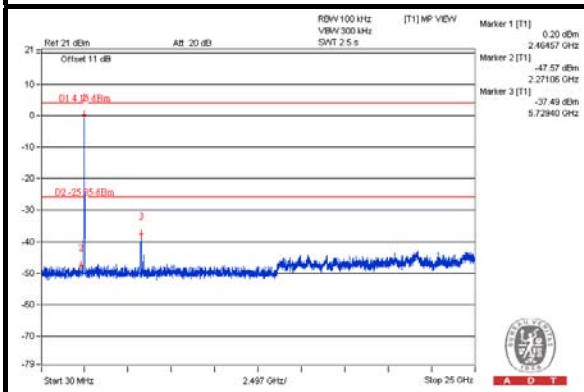

CH 3 Band edge

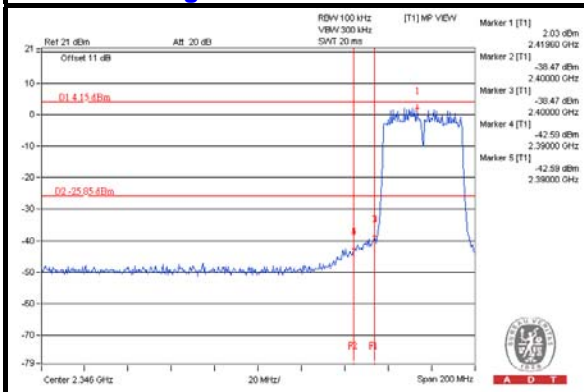

CH 9 Band edge

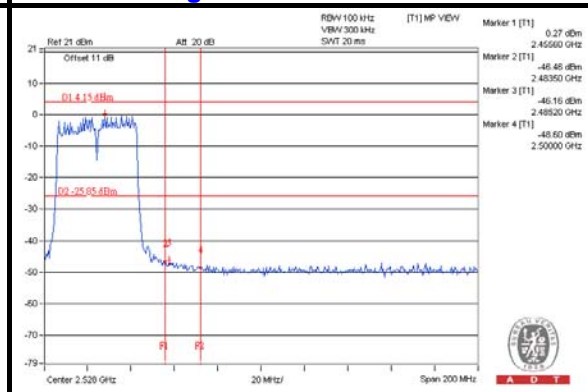



A D T

Chain(1)

CH 3

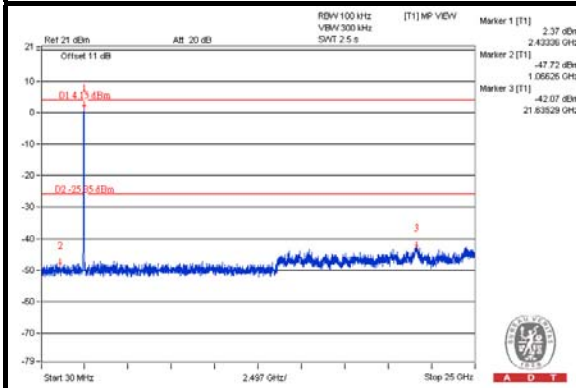

CH 6

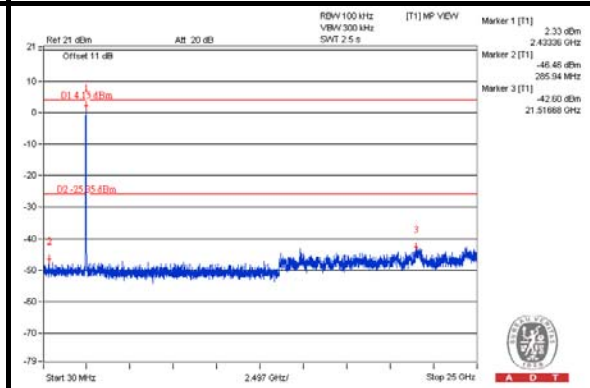

CH 9

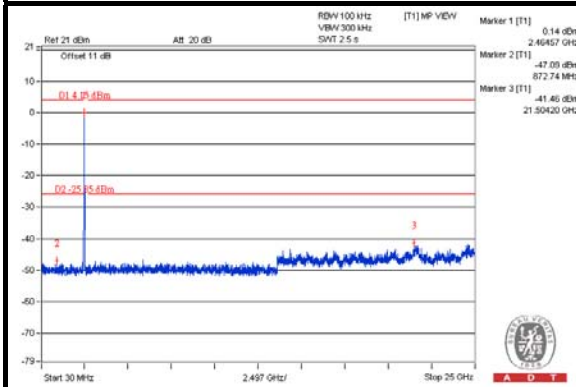

CH 3 Band edge

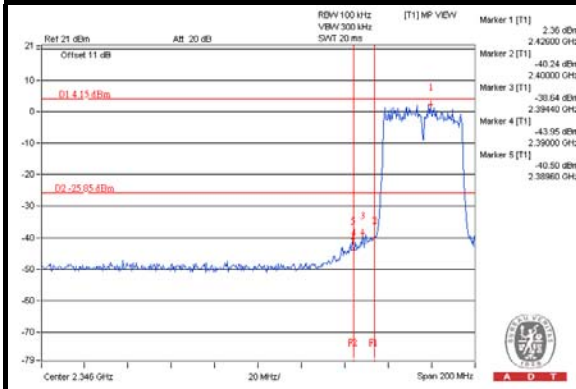

CH 9 Band edge

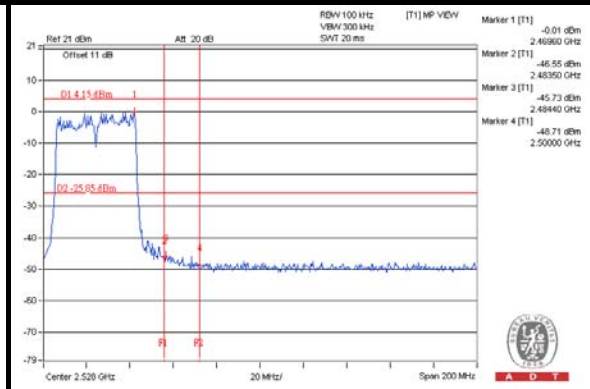



A D T

Chain(2)

CH 3

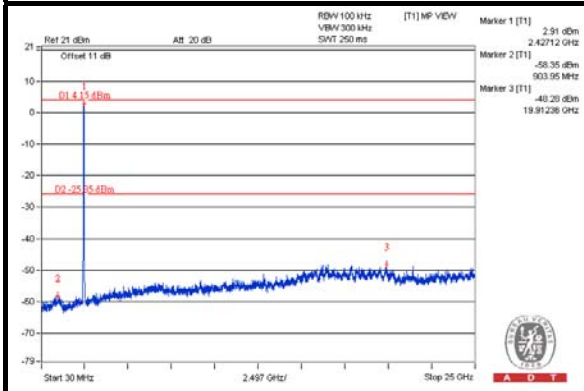

CH 6

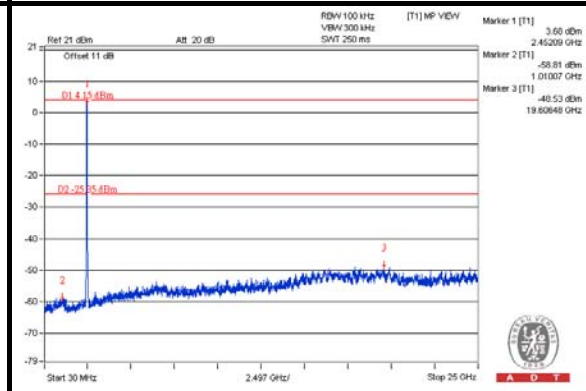

CH 9

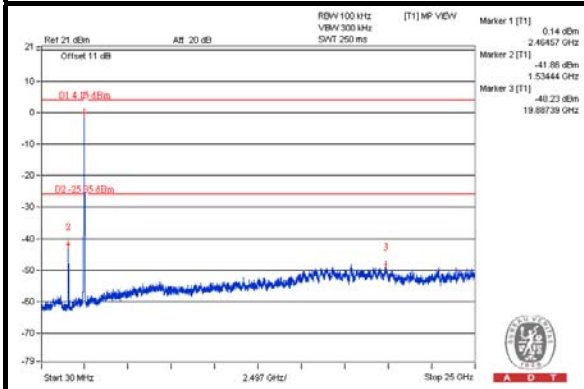

CH 3 Band edge

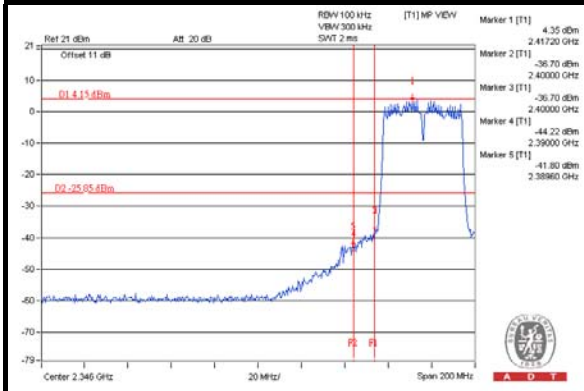

CH 9 Band edge

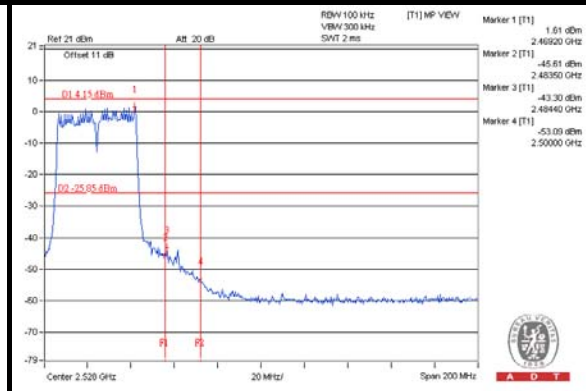



A D T

5. PHOTOGRAPHS OF THE TEST CONFIGURATION

Please refer to the attached file (Test Setup Photo).



A D T

6. INFORMATION ON THE TESTING LABORATORIES

We, Bureau Veritas Consumer Products Services (H.K.) Ltd., Taoyuan Branch, were founded in 1988 to provide our best service in EMC, Radio, Telecom and Safety consultation. Our laboratories are accredited and approved according to ISO/IEC 17025.

If you have any comments, please feel free to contact us at the following:

Linko EMC/RF Lab:

Tel: 886-2-26052180

Fax: 886-2-26052943

Hsin Chu EMC/RF/Telecom Lab:

Tel: 886-3-5935343

Fax: 886-3-5935342

Hwa Ya EMC/RF/Safety Lab:

Tel: 886-3-3183232

Fax: 886-3-3270892

Email: service.adt@tw.bureauveritas.com

Web Site: www.bureauveritas-adt.com

The address and road map of all our labs can be found in our web site also.



A D T

7. APPENDIX A - MODIFICATIONS RECORDERS FOR ENGINEERING CHANGES TO THE EUT BY THE LAB

No modifications were made to the EUT by the lab during the test.

--- END ---