

| REV. | MARK | ECR/ECN NO. | DATE | UPDATE DESCRIPTION | SIGNATURE |
|------|------|-------------|------------|--------------------|-----------|
| 0.0 | N/A | N/A | 2013.12.21 | First Release | Cun |
| 0.1 | | | 2014.03.04 | update PTT label | Cun |

Factory ID list

=====
 (100544-836) FUHONG PRECISION COMPONENT (BAC GIANG) LTD
 DINH TRAM INDUSTRY PARK
 VIET YEN DISTRICT VIET NAM

Factory ID: Y

=====
 (100568-850) NANNING FUGUI PRECISION INDUSTRIAL CO LTD
 18 ZONGBU RD
 NEW & HIGH-TECH INDUSTRIAL
 DEVELOPMENT ZONE
 NANNING GUANGXI CHINA

Factory ID: N

=====
 (128685-001) AMBIT MICROSYSTEMS (SHANGHAI) LTD
 1925 NAN-LE RD
 SONGJIANG EXPORT PROCESSING ZONE
 SHANGHAI
 201613 CHINA

Factory ID: E

=====
 (223850-001) HONG FU JIN PRECISION INDUSTRY
 (SHENZHEN) CO LTD
 10TH YOUSONG INDUSTRIAL DISTRICT
 2ND DONGHUAN RD NO 2
 BAO'AN LONGHUA TOWN
 SHENZHEN 518109 GUANGDONG CHINA

Factory ID: F

PTT label 500.01679.005 42*40mm

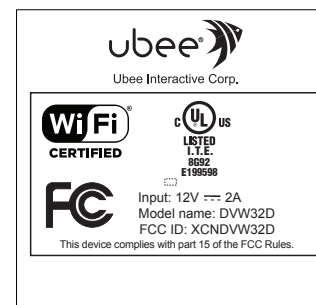

Scale:1/1

Vendor Provide

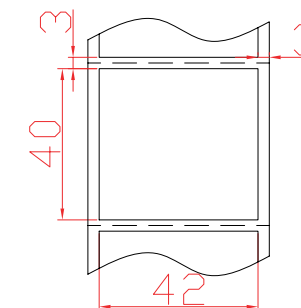

packaging style



Vendor code

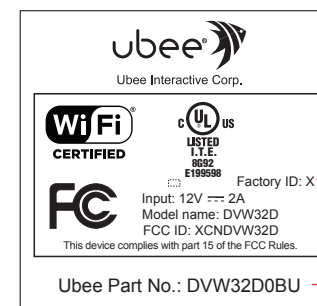

"X": UL Factory ID,
 please see the list, if the manufacturer
 is not in the list, please confirm with
 PM or Compliance Engineer.
 Foxconn printing
 Arial, 5pt

Foxconn printing
 Arial, 7pt

NOTES:

- 1.Material: #50 Mylar + 25# PET(matte, printable)
- 2.Adhesive: 壓花膠
- 3.Adhesive thickness :
 50#Mylar: 0.030+/-0.003mm
 25#PET: 0.018+/-0.003mm
- 4.Printing Color:Black
- 5.Background: White
- 6.Liner:Glassine release paper
- 7.Packaging Style: Reel
- 8.The part must be RoHS compliant
- 9.Mark UL logo and vender code on out packing.
- 10.Adhesion to steel(180°磨鋼粘著力): >/=1.22 Kg/inch
- 11.Initial Tack(初粘力): >/=6 #/boll
- 12.Holding power(保持力):>/=10 hr/Kg/20mm²

| MATERIAL (SPEC.) | | | | | | | | | | SCALE | FOXCONN HON HAI PRECISION IND. CO., LTD. CNSBG | | | |
|------------------|------|------|------|-------|------|--------------------|------|------|------|--------------|---|-------------------------------|----------------------------------|----------------------|
| FINISH | | | | | | | | | | SHEET 1/1 | | | | |
| Select | Dim. | Tol. | A | B | C | EPS | EPE | BAG | CTN | * Label | UNIT MM | PART NAME PTT Label | | |
| 0~6 | 0.05 | 0.05 | 0.10 | / | / | / | / | / | / | 0.20 | SIZE A4 | MODEL U10C091.81 | PART NO. 500.01679.005 | DESIGNED Zhou Cun |
| 6~30 | 0.10 | 0.15 | 0.20 | 0.50 | 0.50 | 3.00 | / | / | 0.20 | | | CUSTOMER MODEL | CUSTOMER PART NO. | APPROVED Yanli Yu |
| 30~120 | 0.15 | 0.20 | 0.30 | 0.50 | 0.50 | 5.00 | 2.00 | 0.25 | | | | | | |
| 120~300 | 0.20 | 0.30 | 0.40 | 1.00 | 1.00 | 10.00 | 3.00 | 0.30 | | | | | | |
| 300~450 | 0.25 | 0.40 | 0.50 | 2.00 | 2.00 | 15.00 | 5.00 | 0.50 | | | | | | |
| 450~600 | 0.30 | 0.50 | 0.60 | 3.00 | 3.00 | 20.00 | 5.00 | 0.80 | | | | | | |
| DRAFT TOLERANCE | | | | ±0.2° | | CRITICAL DIM. MARK | | * | | | | | | |