

5	pallet label	503.00089.005	2/120
4	carton label	503.00092.005	1/10
3	PTT label	500.01738.005	1
2.2	giftbox label	503.01076.005	1
2.1	housing label	503.01076.005	1
1	HH label	503.00096.015	1
Item	Description	Foxconn PN	QTY

U10C093.10

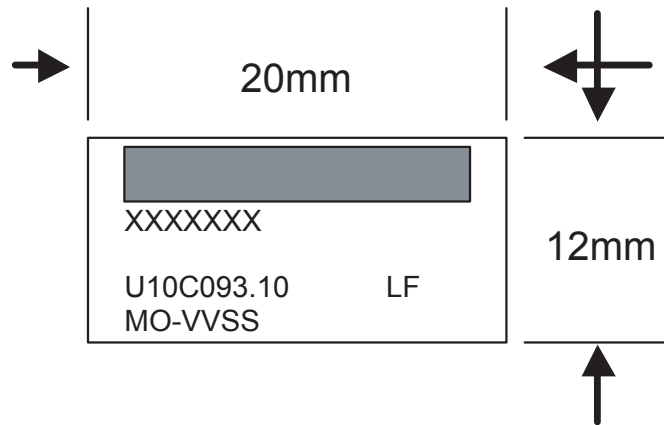

TITLE: HonHai label
P/N:503.00096.015

LABEL TEXT:

1. barcode content

Foxconn barcode: 7digit (code 128)

X XX XXXX

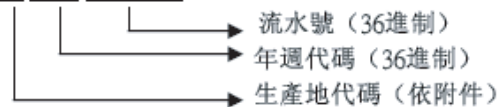

XXXXXXX barcode content words(ditto description)

2. blank for customer

3. Part number: U10C093.10

4. MO-VVSS

Notes:

1. VV:the engineering version(refer to Foxconn label Rev column in the cover of the MFG document)
2. SS:the version of A300/A400 product(refer to Doc Rev. in the cover of MFG document)

產地編號明細

LOCATION	LOCATIONNAME
0	新竹
1	中山
2	福田
3	土城
4	泰詠
5	精陽
6	廣川
7	台表
8	宏鉅
9	新進
A	香港
B	國璉
C	捷克
D	Dummy Lable 用
E	國基
F	龍華D10
G	龍華E5
H	TMM
J	龍華E6
K	觀蘭
L	環電
M	EASTAR
N	龍華CBT
P	龍華RMA
Q	重慶
R	上海RMA
S	上海CPE2
T	煙台(S)
V	煙台(N)
Y	越南(黃田CPEI)
Z	越南(桂武CPEII)
U	越南(桂武CMB)

REV.	MARK	ECR/ECN NO.	DATE	UPDATE DESCRIPTION	SIGNATURE
0.0	N/A	N/A	2014.03.25	First Release	Cun
1	1		2014.06.30	Update label barcode size and font size	Catherine
2	2		2014.07.01	Update password rule	Catherine

NOTES:

- All of the barcode range please refer to the test spec.
- SSID: WIFIXXXXXX-2.4G
XXXXXX: the last 3 octets(6 digits) of the RF MAC address using only uppercase alpha-numeric characters with no punctuation.
- SSID: WIFIXXXXXX-5G
XXXXXX: the last 3 octets(6 digits) of the RF MAC address using only uppercase alpha-numeric characters with no punctuation.
- GUI access URL: <http://192.168.100.1>
- GUI username: admin
- GUI password: XXXXXXXXXXXXX
XXXXXXXXXXXX: 12 characters, must be a randomly generated character string, created individually for each unit at time of manufacture. (It MUST be restricted to some combination of uppercase alphabetical letters, lowercase alphabetical letters, number characters, and printable special characters.)
Special characters must be limited to: !, #, \$, &, %, * The following characters are not allowed: upper case O (OH), 0 (zero), lower case l (el), upper case I (EYE) upper case S, upper case B.
- WPA2-PSK: XXXXXXXXXXXXXXXX
16 characters, must be a randomly generated character string, created individually for each unit at time of manufacture (It must use only uppercase alpha-numeric characters, excluding the number "0" and "O", with no punctuation)
- WPS PIN: XXXXXXXX
The format of the PIN must be a randomly generated eight(8) digit number in accordance with the WPS specification.
- H/W Version: X.X.X
Please refer to test spec., it's same as "H/W version check"
- DC (Date Code), in MMDDYY format: MM表示月, DD表示天, YY表示年
- ASSEMBLED IN XXXXX
(XXXXX: Country of Manufacture, base on the manufacture factory)

Housing Label
503.01076.005-1
stick on housing

Box Label
503.01076.005-2
stick on box

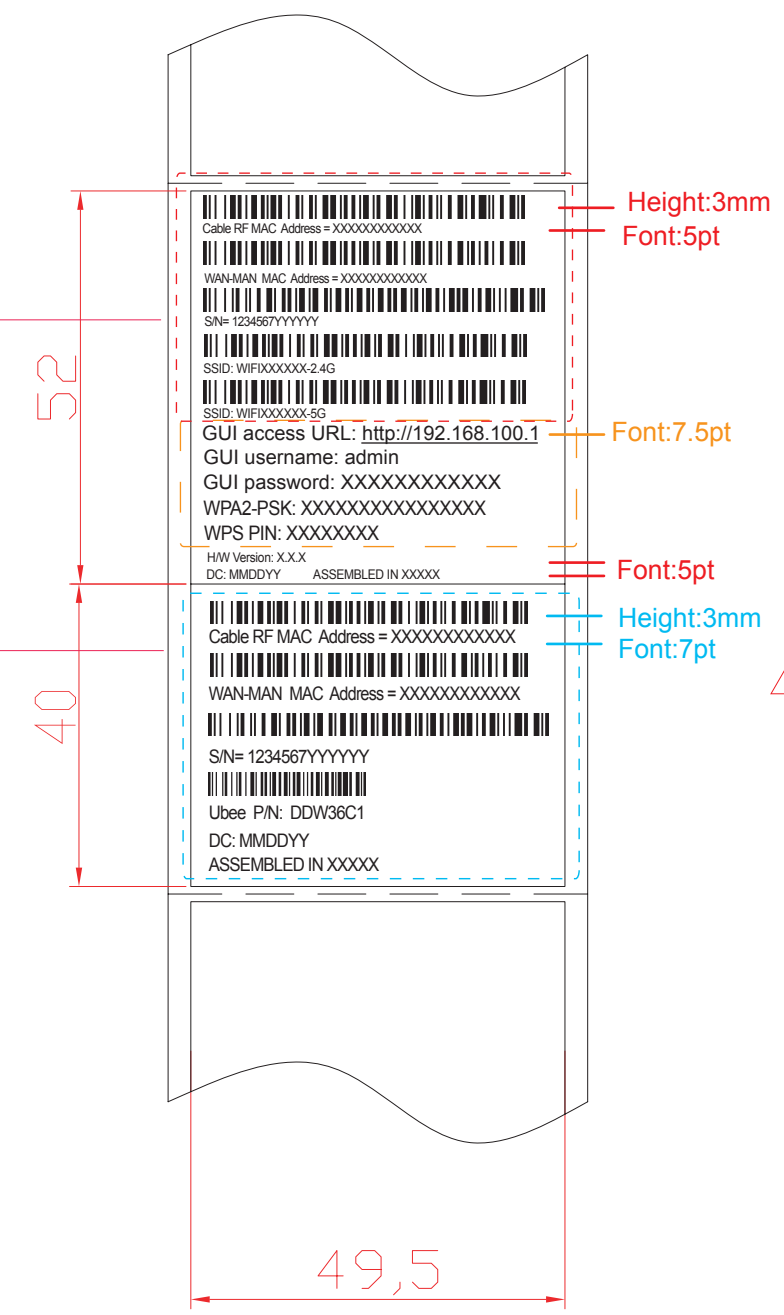

Barcode format: code 128
Font: Arial

MATERIAL (SPEC.) 50# Mylar		SCALE	 HON HAI PRECISION IND. CO., LTD. CNSBG		
FINISH		SHEET 1/1			
Select			UNIT	PART NAME	
Dim. Tol.	A B C EPS EPE BAG CTN Label	USR	MM	Housing Label+Box Label	
0~6	0.05 0.05 0.10			MODEL	PART NO.
6~30	0.10 0.15 0.20 0.50 0.50 3.00			U10C093.10	503.01076.005
30~120	0.15 0.20 0.30 0.50 0.50 5.00 2.00	0.25	SIZE	DESIGNED	
120~300	0.20 0.30 0.40 1.00 1.00 10.00 3.00	0.30	A4	Catherine	
300~450	0.25 0.40 0.50 2.00 2.00 15.00 5.00	0.50		APPROVED	
450~600	0.30 0.50 0.60 3.00 3.00 20.00 5.00	0.80		Sunny	
DRAFT TOLERANCE		± 0.2°	CRITICAL DIM. MARK	*	

REV.	MARK	ECR/ECN NO.	DATE	UPDATE DESCRIPTION	SIGNATURE
0.0	N/A	N/A	2014.03.19	First Release	Cun
0.1			2014.04.23	update rating	Cun
0.2			2014.06.17	update FCC ID and Model name	Catherine

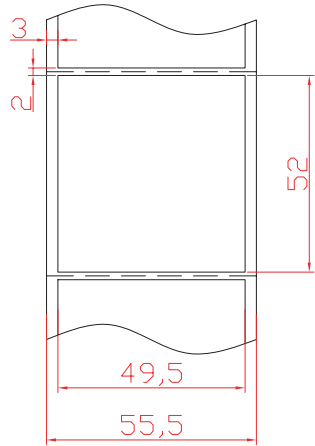

Package style

Factory ID list

(100544-836) FUHONG PRECISION COMPONENT (BAC GIANG) LTD
DINH TRAM INDUSTRY PARK
VIET YEN DISTRICT VIET NAM

Factory ID: Y

(100568-850) NANNING FUGUI PRECISION INDUSTRIAL CO LTD
18 ZONGBU RD
NEW & HIGH-TECH INDUSTRIAL
DEVELOPMENT ZONE
NANNING GUANGXI CHINA

Factory ID: N

(128685-001) AMBIT MICROSYSTEMS (SHANGHAI) LTD
1925 NAN-LE RD
SONGJIANG EXPORT PROCESSING ZONE
SHANGHAI
201613 CHINA

Factory ID: E

(223850-001) HONG FU JIN PRECISION INDUSTRY
(SHENZHEN) CO LTD
10TH YOUSONG INDUSTRIAL DISTRICT
2ND DONGHUAN RD NO 2
BAO'AN LONGHUA TOWN
SHENZHEN 518109 GUANGDONG CHINA

Factory ID: F

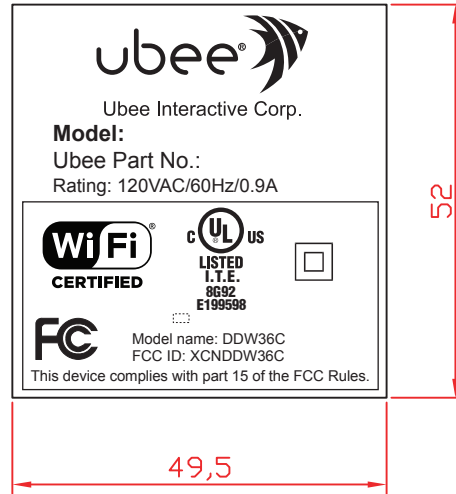

Vendor provide



Vendor code

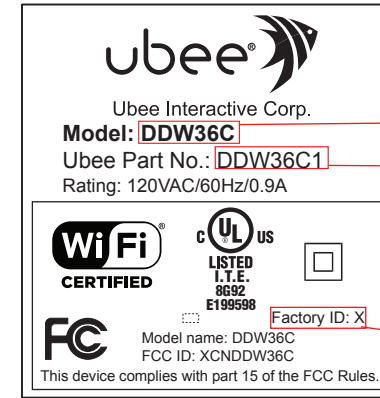

Foxconn printing
Arial Bold, 8.4pt

Foxconn printing
Arial Regular, 8.4pt



































"X": UL Factory ID,
Foxconn printing
Arial 6pt

NOTES:

1. Material: #50 Mylar + 25# PET (matte, printable)
2. Adhesive: 壓花膠
3. Adhesive thickness :
50#Mylar: 0.030+/-0.003mm
25#PET: 0.018+/-0.003mm
4. Printing Color: Black
5. Background: White
6. Liner: Glassine release paper
7. Packaging Style: Reel
8. The part must be RoHS compliant

MATERIAL (SPEC.)										SCALE		FOXCONN HON HAI PRECISION IND. CO., LTD. CNSBG			
FINISH										1/1					
Select										SHEET		PART NAME			
Dim.	Tol.	A	B	C	EPS	EPE	BAG	CTN	Label	USR	1/1		PTT Label		
										UNIT		MODEL			
										MM		U10C093.10			
										SIZE		PART NO.			
										A4		500.01738.005			
										DESIGNED		CUSTOMER MODEL			
										Sunny		CUSTOMER PART NO.			
DRAFT TOLERANCE										± 0.2°		APPROVED			
										CRITICAL DIM. MARK *		Catherine			
0~6	0.05	0.05	0.10	0.50	0.50	3.00	0.20								
6~30	0.10	0.15	0.20	0.50	0.50	3.00	0.20								
30~120	0.15	0.20	0.30	0.50	0.50	5.00	2.00	0.25							
120~300	0.20	0.30	0.40	1.00	1.00	10.00	3.00	0.30							
300~450	0.25	0.40	0.50	2.00	2.00	15.00	5.00	0.50							
450~600	0.30	0.50	0.60	3.00	3.00	20.00	5.00	0.80							

D		C		B		A
REV.	MARK	ECR/ECN NO.	DATE	UPDATE	DESCRIPTION	SIGNATURE
0	N/A	N/A	2014.03.20		First Release	Cun

Product:  Ubee P/N: DDW36C1		Qty: 10 
 Foxconn P/N: U10C093.10		Assembled in DATE: MM/DD/YY XXXXXX TIME: HH:MM
Carton ID:  CXXXXXXXXXX		
Serial Number	Cable RF MAC	WAN-MAN MAC
 1234567YYYYYY	 XXXXXXXXXXXXX	 XXXXXXXXXXXXX
 1234567YYYYYY	 XXXXXXXXXXXXX	 XXXXXXXXXXXXX
 1234567YYYYYY	 XXXXXXXXXXXXX	 XXXXXXXXXXXXX
 1234567YYYYYY	 XXXXXXXXXXXXX	 XXXXXXXXXXXXX
 1234567YYYYYY	 XXXXXXXXXXXXX	 XXXXXXXXXXXXX
 1234567YYYYYY	 XXXXXXXXXXXXX	 XXXXXXXXXXXXX
 1234567YYYYYY	 XXXXXXXXXXXXX	 XXXXXXXXXXXXX
 1234567YYYYYY	 XXXXXXXXXXXXX	 XXXXXXXXXXXXX
 1234567YYYYYY	 XXXXXXXXXXXXX	 XXXXXXXXXXXXX
 1234567YYYYYY	 XXXXXXXXXXXXX	 XXXXXXXXXXXXX
THIS PRODUCT CONTAINS ENCRYPTION AND MAY REQUIRE U.S. AND/OR LOCAL GOVERNMENT AUTHORIZATION PRIOR TO EXPORT OR IMPORT TO ANOTHER COUNTRY		

165.1

101.6

- Notes:
1. Background color: White
 2. Printing color: Black
 3. Material: art paper
 4. Size: 101.6mm*165.1mm
 5. Carton ID: follow Foxconn rule
 6. DATE/TIME (Variable) that modem was assembled
According to the actual manufacturing time to print
DATE: MM/DD/YY (e.g.: DATE: 04/23/12)
TIME: HH:MM (e.g.: TIME: 14:52)
 7. Assembled in XXXXXX: Country of Manufacture
(base on the manufacture factory)
 8. MAC and SN range please refer to the test spec.
 9. Stick position please refer to ASY document

Font: Arial
Barcode: code 128

MATERIAL (SPEC.)										SCALE 4/5	FOXCONN HON HAI PRECISION IND. CO., LTD. CNSBG																																																																																		
FINISH										SHEET 1/1																																																																																			
<table border="1"> <thead> <tr> <th>Select</th> <th></th> <th></th> <th></th> <th></th> <th></th> <th></th> <th></th> <th>*</th> <th></th> </tr> <tr> <th>Dim.</th> <th>Tot.</th> <th>A</th> <th>B</th> <th>C</th> <th>EPS</th> <th>EPE</th> <th>BAG</th> <th>CTN</th> <th>Label</th> </tr> </thead> <tbody> <tr> <td>0~6</td> <td>0.05</td> <td>0.05</td> <td>0.10</td> <td></td> <td></td> <td></td> <td></td> <td></td> <td>0.20</td> </tr> <tr> <td>6~30</td> <td>0.10</td> <td>0.15</td> <td>0.20</td> <td>0.50</td> <td>0.50</td> <td>3.00</td> <td></td> <td></td> <td>0.20</td> </tr> <tr> <td>30~120</td> <td>0.15</td> <td>0.20</td> <td>0.30</td> <td>0.50</td> <td>0.50</td> <td>5.00</td> <td>2.00</td> <td>0.25</td> <td></td> </tr> <tr> <td>120~300</td> <td>0.20</td> <td>0.30</td> <td>0.40</td> <td>1.00</td> <td>1.00</td> <td>10.00</td> <td>3.00</td> <td>0.30</td> <td></td> </tr> <tr> <td>300~450</td> <td>0.25</td> <td>0.40</td> <td>0.50</td> <td>2.00</td> <td>2.00</td> <td>15.00</td> <td>5.00</td> <td>0.50</td> <td></td> </tr> <tr> <td>450~600</td> <td>0.30</td> <td>0.50</td> <td>0.60</td> <td>3.00</td> <td>3.00</td> <td>20.00</td> <td>5.00</td> <td>0.80</td> <td></td> </tr> </tbody> </table>										Select								*		Dim.	Tot.	A	B	C	EPS	EPE	BAG	CTN	Label	0~6	0.05	0.05	0.10						0.20	6~30	0.10	0.15	0.20	0.50	0.50	3.00			0.20	30~120	0.15	0.20	0.30	0.50	0.50	5.00	2.00	0.25		120~300	0.20	0.30	0.40	1.00	1.00	10.00	3.00	0.30		300~450	0.25	0.40	0.50	2.00	2.00	15.00	5.00	0.50		450~600	0.30	0.50	0.60	3.00	3.00	20.00	5.00	0.80		UNIT MM	PART NAME Carton Label		
Select								*																																																																																					
Dim.	Tot.	A	B	C	EPS	EPE	BAG	CTN	Label																																																																																				
0~6	0.05	0.05	0.10						0.20																																																																																				
6~30	0.10	0.15	0.20	0.50	0.50	3.00			0.20																																																																																				
30~120	0.15	0.20	0.30	0.50	0.50	5.00	2.00	0.25																																																																																					
120~300	0.20	0.30	0.40	1.00	1.00	10.00	3.00	0.30																																																																																					
300~450	0.25	0.40	0.50	2.00	2.00	15.00	5.00	0.50																																																																																					
450~600	0.30	0.50	0.60	3.00	3.00	20.00	5.00	0.80																																																																																					
DRAFT TOLERANCE ±0.2° CRITICAL DIM. MARK *										SIZE A4	MODEL U10C093.10	PART NO. 503.00092.005	DESIGNED Zhou Cun																																																																																
											CUSTOMER MODEL	CUSTOMER PART NO.	APPROVED Yanli Yu																																																																																

Hon Hai Pallet Label:503.00089.005



Size:110mm*36mm

P/N:U10C093.10

Barcode and words description:

barcode 1: Ubee PN: DDW36C1

barcode 2: PIPPYWWSSSS

1. PIPPYWWSSSS:

P:Pallet,

I:Location name,refer to reference

PP:Line name,

Y:Year,

WW:Week,

SSSS:Serial number (0001-ZZZZ, reset to 0001 every week)

2. Rev:VVSS:Product manufacturing document revision

VV:the engineering version(refer to Foxconn label Rev column in the cover of the MFG document)

SS:the version of A300/A400 product(refer to Doc Rev. in the cover of MFG document)