







MEASUREMENT REPORT

FCC ID : XBG-BA1GMNRCH12
APPLICANT : AVALUE TECHNOLOGY INCORPORATION
Application Type : Certification
Product : Intercom
Model Name : Monarch 12
Model Number : BUTTERFLYMX.M12.1
Trade Mark : 
FCC Classification : PCS Licensed Transmitter (PCB)
FCC Rule Part(s) : Part2, Part90
Test Procedure(s) : ANSI/TIA-603-E-2016
Received Date : September 13, 2022
Test Date : September 23 ~ November 18, 2022

Tested By : 
(Wen Lee)
Reviewed By : 
(Paddy Chen)
Approved By : 
(Chenz Ker)



The test results only relate to the tested sample.

This equipment has been shown to be capable of compliance with the applicable technical standards as indicated in the measurement report and was tested in accordance with the measurement procedures specified in §2.947. Test results reported herein relate only to the item(s) tested.

The test report shall not be reproduced except in full without the written approval of MRT Technology (Taiwan) Co., Ltd.

Revision History

Report No.	Version	Description	Issue Date	Note
2209TWI301-U9	1.0	Original Report	2022-12-15	

CONTENTS

Description	Page
1. INTRODUCTION	6
1.1. Scope	6
1.2. MRT Test Location	6
2. PRODUCT INFORMATION	7
2.1. Feature of Equipment under Test.....	7
2.2. Equipment Description	8
2.3. Device Capabilities	8
2.4. Test Configuration	8
2.5. EMI Suppression Device(s)/Modifications.....	8
3. DESCRIPTION OF TEST	9
3.1. Evaluation Procedure	9
3.2. Cellular – Base Frequency Blocks	9
3.3. Cellular – Mobile Frequency Blocks.....	9
3.4. PCS – Base Frequency Blocks.....	10
3.5. PCS – Mobile Frequency Blocks	10
3.6. Occupied Bandwidth.....	11
3.7. Spurious and Harmonic Emissions at Antenna Terminal	11
3.8. Power and Radiated Spurious Emissions	12
3.9. Peak-Average Ratio	13
3.10. Frequency Stability / Temperature Variation	13
4. TEST EQUIPMENT CALIBRATION DATE.....	14
5. SAMPLE CALCULATIONS.....	15
6. MEASUREMENT UNCERTAINTY.....	16
7. TEST RESULT	17
7.1. Summary.....	17
7.2. Occupied Bandwidth.....	19
7.2.1. Test Limit	19
7.2.2. Test Procedure used.....	19
7.2.3. Test Setting.....	19
7.2.4. Test Setup	19
7.2.5. Test Result.....	20
7.3. Conducted Spurious Emissions.....	23
7.3.1. Test Limit	23

7.3.2.	Test Procedure Used	23
7.3.3.	Test Setting	23
7.3.4.	Test Setup	23
7.3.5.	Test Result	24
7.4.	Band Edge at Antenna Terminal	33
7.4.1.	Test Limit	33
7.4.2.	Test Procedure Used	33
7.4.3.	Test Setting	34
7.4.4.	Test Setup	34
7.4.5.	Test Result	35
7.5.	Power and Radiated Spurious Emissions	42
7.5.1	Test Limit	42
7.5.2	Test Procedure Used	42
7.5.3	Test Setting	43
7.5.4	Test Setup	45
7.5.5	Test Result	46
7.6.	Peak-Average Ratio	49
7.6.1	Test Limit	49
7.6.2	Test Procedure	49
7.6.3	Test Setup	49
7.6.4	Test Result	50
7.7.	Frequency Stability Under Temperature & Voltage Variations	53
7.7.1	Test Limit	53
7.7.2	Test Procedure	53
7.7.3	Test Setup	53
7.7.4	Test Result	54

§2.1033 General Information

Applicant	AVALUE TECHNOLOGY INCORPORATION
Applicant Address	7F, 228, Lian-cheng Road, Zhonghe Dist., New Taipei City 235, Taiwan
Manufacturer	ButterflyMX, inc.
Manufacturer Address	44 West 28th Street, 4th Floor New York, NY 10001
Test Site	MRT Technology (Taiwan) Co., Ltd
Test Site Address	No. 38, Fuxing Second Rd., Guishan Dist., Taoyuan City 333, Taiwan (R.O.C)
MRT FCC Registration No.	291082
FCC Rule Part(s)	Part 90
Test Device Serial No.	#1-1 <input type="checkbox"/> Production <input checked="" type="checkbox"/> Pre-Production <input type="checkbox"/> Engineering

Test Facility / Accreditations

Measurements were performed at MRT Laboratory located in Fuxing Rd., Taoyuan, Taiwan (R.O.C)

- MRT facility is a FCC registered (Reg. No. 291082) test facility with the site description report on file and is designated by the FCC as an Accredited Test Firm.
- MRT facility is an IC registered (MRT Reg. No. 21723) test laboratory with the site description on file at Industry Canada.
- MRT Lab is accredited to ISO 17025 by the Taiwan Accreditation Foundation (TAF Cert. No. 3261) in EMC, Telecommunications and Radio testing for FCC (Designation Number: TW3261), Industry Taiwan, EU and TELEC Rules.

1. INTRODUCTION

1.1. Scope

Measurement and determination of electromagnetic emissions (EMC) of radio frequency devices including intentional and/or unintentional radiators for compliance with the technical rules and regulations of the Federal Communications Commission and the Industry Canada Certification and Engineering Bureau.

1.2. MRT Test Location

The map below shows the location of the MRT LABORATORY, its proximity to the Taoyuan City. These measurement tests were conducted at the MRT Technology (Taiwan) Co., Ltd. Facility located at No.38, Fuxing 2nd Rd., Guishan Dist., Taoyuan City 33377, Taiwan (R.O.C).

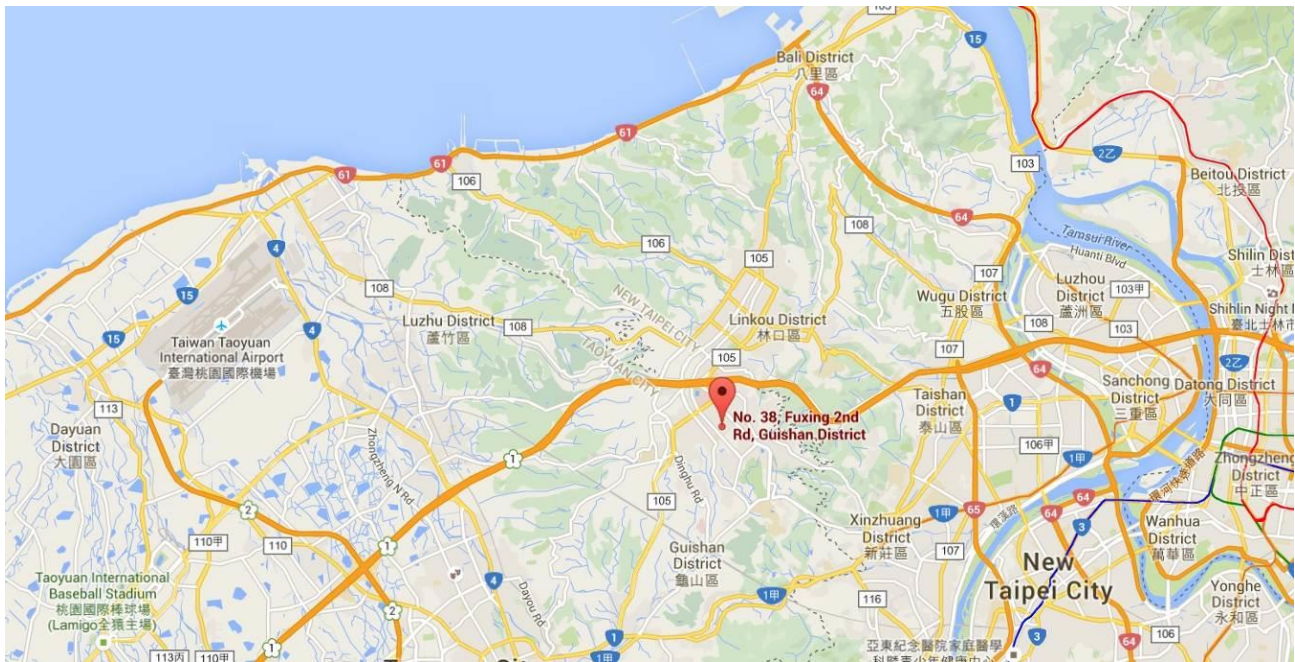

2. PRODUCT INFORMATION

2.1. Feature of Equipment under Test

Product Name	Intercom
Trade Mark	 ButterflyMX
Model Name	Monarch 12
Model Number	BUTTERFLYMX.M12.1
Supports Radios Spec.	<p>WPAN: Bluetooth Dual Mode: V5.0 RFID: 125kHz & 13.56MHz</p> <p>WLAN: 2.4G: 802.11b/g/n-20/n-40 5G: 802.11a/n-20/ac-20/n-40/ac-40/ac-80, Band 1,4</p> <p>WWAN: 4G: Band 2,4,5,7,12,13,25,26,38,41</p>
4G Operation Band (s)	Band 26
Frequency Range	Band26: 814MHz–824MHz

2.2. Equipment Description

Antenna Type	FPCB
Antenna M/N	YFCA002FA
Antenna Gain	Band 26: -3.00dBi
Type of Modulation	QPSK, 16QAM

Note:

1. The test report has showed the worst test mode.

2.3. Device Capabilities

This device contains the following capabilities:

LTE Band 26.

2.4. Test Configuration

The **Intercom** was tested per the guidance of ANSI/TIA-603-E-2016 and KDB 971168 D01v02r02. See section 3.0 of this report for a description of the radiated and antenna port conducted emissions tests.

2.5. EMI Suppression Device(s)/Modifications

No EMI suppression device(s) were added and no modifications were made during testing.

3. DESCRIPTION OF TEST

3.1. Evaluation Procedure

The measurement procedures described in the “Land Mobile FM or PM – Communications Equipment – Measurements and Performance Standards” (ANSI/TIA-603-E-2016) and “Procedures for Compliance Measurement of the Fundamental Emission Power of Licensed Wideband (> 1 MHz) Digital Transmission Systems” (KDB 971168) were used in the measurement of the **Intercom**

Deviation from measurement procedure.....None

3.2. Cellular – Base Frequency Blocks

§22.905

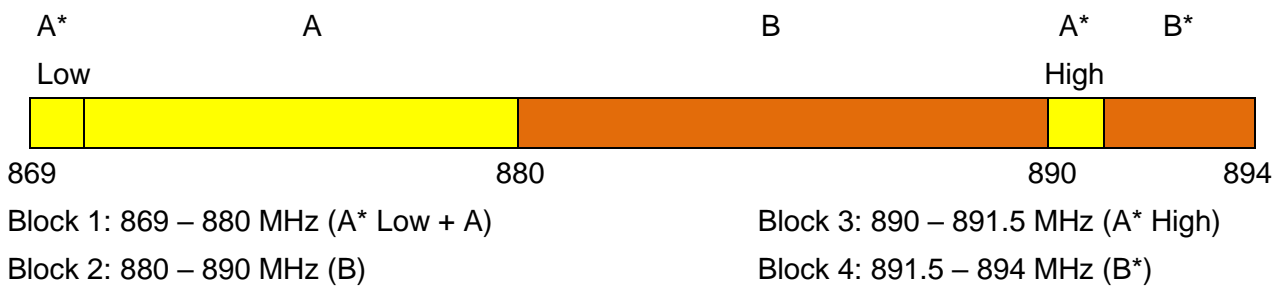

3.3. Cellular – Mobile Frequency Blocks

§22.905

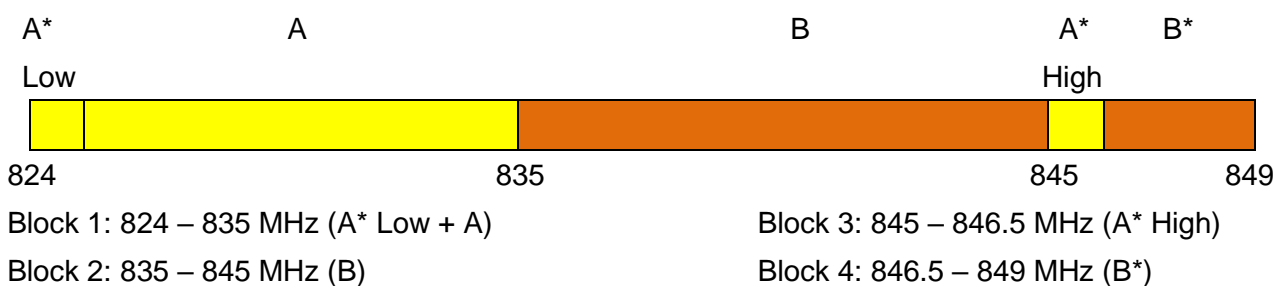

3.4. PCS – Base Frequency Blocks

§24.229

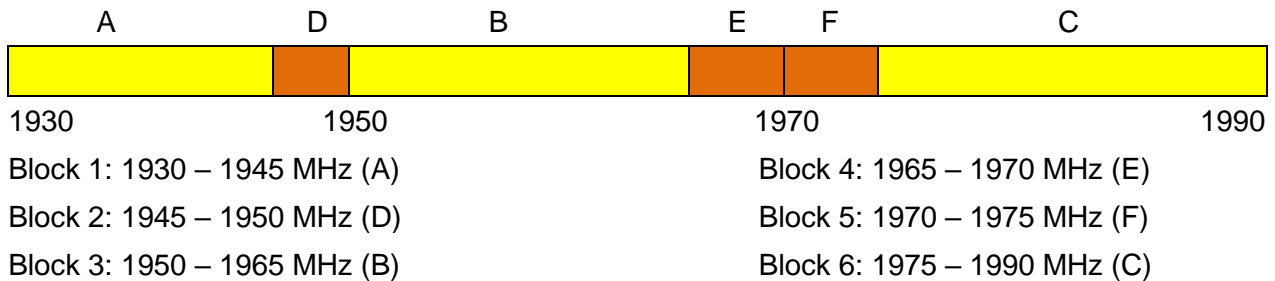

3.5. PCS – Mobile Frequency Blocks

§24.229

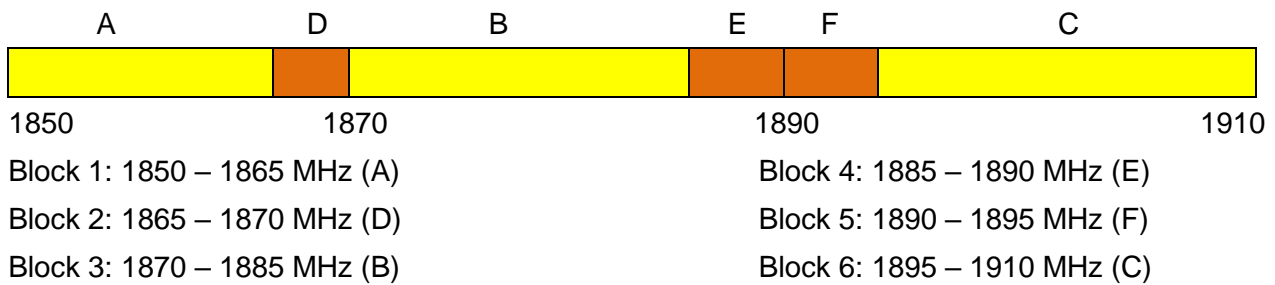

3.6. Occupied Bandwidth

§2.1049

The occupied bandwidth, that is the frequency bandwidth such that, below its lower and above its upper frequency limits, the mean powers radiated are each equal to 0.5 percent of the total mean power radiated by a given emission shall be measured. The spectrum analyzers' "occupied bandwidth" measurement function was used to record the occupied bandwidth in accordance with KDB 971168.

3.7. Spurious and Harmonic Emissions at Antenna Terminal

§2.1051 §22.917(a) §24.238(a) §90.543 §90.691

The level of the carrier and the various conducted spurious and harmonic frequencies is measured by means of a calibrated spectrum analyzer. The spectrum is scanned from the lowest frequency generated in the equipment up to a frequency including its 10th harmonic. On any frequency outside a licensee's frequency block, the power of any emission shall be attenuated below the transmitter power (P) by at least $43 + 10 \log(P)$ dB. Compliance with these provisions is based on the use of measurement instrumentation employing a resolution bandwidth of 100 kHz or greater for Part 22. However, in the 1 MHz bands immediately outside and adjacent to the frequency block a resolution bandwidth of at least one percent of the emission bandwidth of the fundamental emission of the transmitter may be employed. The emission bandwidth is defined as the width of the signal between two points, one below the carrier center frequency and one above the carrier center frequency, outside of which all emission are attenuated at least 26 dB below the transmitter power.

3.8. Power and Radiated Spurious Emissions

§2.1053 §22.913(a.2) §22.917(a) §24.232(c) §24.238(a) §90.542 §90.635

The radiated test facilities consisted of an indoor 3 meter semi-anechoic chamber used for final measurement and exploratory measurements, when necessary. The measurement area is contained within the semi-anechoic chamber which is shielded from any ambient interference. For measurements above 1GHz absorbers are arranged on the floor between the turn table and the antenna mast in such a way so as to maximize the reduction of reflections. For measurements below 1GHz, the absorbers are removed. A MF Model 210SS turntable is used for radiated measurement. It is a continuously rotatable, remote-controlled, metallic turntable and 2 meters (6.56 ft.) in diameter. The turn table is flush with the raised floor of the chamber in order to maintain its function as a ground plane. A 80cm high PVC support structure is placed on top of the turntable.

The equipment under test was transmitting while connected to its integral antenna and is placed on a wooden turntable 80cm above the ground plane and 3 meters from the receive antenna. The receive antenna height is adjusted between 1 and 4 meter height, the turntable is rotated through 360 degrees, and the EUT is manipulated through all orthogonal planes representative of its typical use to achieve the highest reading on the receive spectrum analyzer. Radiated power levels are also investigated with the receive antenna horizontally and vertically polarized. The maximized power level is recorded using the spectrum analyzer "Channel Power" function with the integration band set to the emissions' occupied bandwidth, a RMS detector, RBW = 100kHz, VBW = 300kHz, and a 1 second sweep time over a minimum of 10 sweeps, per the guidelines of KDB 971168.

Per the guidance of ANSI/TIA-603-E-2016, a half-wave dipole is then substituted in place of the EUT. For emissions above 1GHz, a horn antenna is substituted in place of the EUT. The substitute antenna is driven by a signal generator with the level of the signal generator being adjusted to obtain the same receive spectrum analyzer level previously recorded from the spurious emission from the EUT. The power of the emission is calculated using the following formula:

$$P_d \text{ [dBm]} = P_g \text{ [dBm]} - \text{cable loss [dB]} + \text{antenna gain [dBd/dBi]}$$

Where, P_d is the dipole equivalent power, P_g is the generator output into the substitution antenna, and the antenna gain is the gain of the substitute antenna used relative to either a half-wave dipole (dBd) or an isotropic source (dBi). The substitute level is equal to $P_g \text{ [dBm]} - \text{cable loss [dB]}$.

The calculated P_d levels are then compared to the absolute spurious emission limit of -13dBm which is equivalent to the required minimum attenuation of $43 + 10 \cdot \log_{10}(\text{Power [Watts]})$ specified in 22.917(a).

3.9. Peak-Average Ratio

§24.232(d)

A peak to average ratio measurement is performed at the conducted port of the EUT. The spectrum analyzers Complementary Cumulative Distribution Function (CCDF) measurement profile is used to determine the largest deviation between the average and the peak power of the EUT in a given bandwidth. The CCDF curve shows how much time the peak waveform spends at or above a given average power level. The percent of time the signal spends at or above the level defines the probability for that particular power level.

For pulsed signals, the spectrum analyzer is set to use an internal “RF Burst” trigger that is synced with an incoming pulse and the measurement interval is set to less than the duration of the “on time” of one burst to ensure that energy is only captured during a time in which the transmitter is operating at maximum power. For continuous signals, the trigger is set to “free run” in the CCDF measurement mode.

3.10. Frequency Stability / Temperature Variation

§2.1055 §22.355 §22.863 §22.905 §24.229 §24.235 §90.213

Frequency stability testing is performed in accordance with the guidelines of ANSI/TIA-603-E-2016.

The frequency stability of the transmitter is measured by:

- a.) Temperature: The temperature is varied from -30°C to +50°C in 10°C increments using an environmental chamber.
- b.) Primary Supply Voltage: The primary supply voltage is varied from 85% to 115% of the nominal value for non hand-carried battery and AC powered equipment. For hand-carried, battery-powered equipment, primary supply voltage is reduced to the battery operating end point which shall be specified by the manufacturer.

Specification – For Part 22, the frequency stability of the transmitter shall be maintained within $\pm 0.00025\%$ (± 2.5 ppm) of the center frequency.

Time Period and Procedure:

1. The carrier frequency of the transmitter is measured at room temperature (20°C to provide a reference).
2. The equipment is turned on in a “standby” condition for fifteen minutes before applying power to the transmitter. Measurement of the carrier frequency of the transmitter is made within one minute after applying power to the transmitter.
3. Frequency measurements are made at 10°C intervals ranging from -30°C to +50°C. A period of at least one half-hour is provided to allow stabilization of the equipment at each temperature level.

4. TEST EQUIPMENT CALIBRATION DATE

Conducted Emissions – SR2

Instrument	Manufacturer	Type No.	Asset No.	Cali. Interval	Cali. Due Date
Two-Line V-Network	R&S	ENV216	MRTTWA00019	1 year	2023/3/7
Cable	Rosnol	N1C50-RG400-B 1C50-500CM	MRTTWE00013	1 year	2023/6/21
EMI Test Receiver	R&S	ESR3	MRTTWA00009	1 year	2023/3/9

Radiated Emissions – AC1

Instrument	Manufacturer	Type No.	Asset No.	Cali. Interval	Cali. Due Date
Broadband TRILOG Antenna	SCHWARZBECK	VULB 9162	MRTTWA00001	1 year	2022/12/30
EMI Test Receiver	R&S	ESR3	MRTTWA00009	1 year	2023/3/9
Active Loop Antenna	Schwarzbeck	FMZB 1519B	MRTTWA00002	1 year	2023/5/24
Broadband Horn antenna	SCHWARZBECK	BBHA 9120D	MRTTWA00003	1 year	2023/3/30
Breitband Hornantenna	Schwarzbeck	BBHA 9170	MRTTWA00004	1 year	2023/3/29
Broadband Amplifier	Schwarzbeck	BBV 9721	MRTTWA00006	1 year	2023/3/30
Broadband Preampifier	SCHWARZBECK	BBV 9718	MRTTWA00005	1 year	2023/3/30
Cable	HUBERSUHNER	SF106	MRTTWE00010	1 year	2023/6/14
Cable	Rosnol	K1K50-UP0264- K1K50-4M	MRTTWE00012	1 year	2023/6/19

Conducted Test Equipment –SR5

Instrument	Manufacturer	Type No.	Asset No.	Cali. Interval	Cali. Due Date
EXA Signal Analyzer	KEYSIGHT	N9010A	MRTTWA00012	1 year	2023/10/5
EXA Signal Analyzer	KEYSIGHT	N9010B	MRTTWA00074	1 year	2023/7/19
USB Wideband Power Sensor	KEYSIGHT	U2021XA	MRTTWA00015	1 year	2023/3/16
Wideband Radio Communication Taster	R&S	CMW 500	MRTTWA00084	1 year	2023/10/18

Test Software

Software	Version	Function
e3	9.160520a	EMI Test Software
EMI	V3	EMI Test Software

5. SAMPLE CALCULATIONS

GSM Emission Designator

Emission Designator = 250KGXW

GSM BW = 250 kHz

G = Phase Modulation

X = Cases not otherwise covered

W = Combination (Audio/Data)

EGPRS Emission Designator

Emission Designator = 250KG7W

GSM BW = 250 kHz

G = Phase Modulation

7 = Quantized/Digital Info

W = Combination (Audio/Data)

WCDMA / CDMA Emission Designator

Emission Designator = 1M25F9W

WCDMA BW = 1.25 MHz

F = Frequency Modulation

9 = Composite Digital Info

W = Combination (Audio/Data)

LTE Emission Designator

Emission Designator = QPSK 5M00G7D / 16QAM 5M00W7D

LTE BW = 1.4/3/5/10/15/20 MHz

QPSK G = Phase Modulation /

16QAM W= in a combination of two or more of the following modes: amplitude, angle, pulse

7 = Quantized/Digital Info

D = Data transmission, telemetry, telecommand

Spurious Radiated Emission

Example: Spurious emission at 1688.10 MHz

The receive spectrum analyzer reading at 3 meters with the EUT on the turntable was -65.0dBm . The gain of the substituted antenna is 6.5dBi . The signal generator connected to the substituted antenna terminals is adjusted to produce a reading of -65.0dBm on the spectrum analyzer. The loss of the cable between the signal generator and the terminals of the substituted antenna is 4.5 dB at 1688.1MHz . So 2 dB is added to the signal generator reading of -25dBm yielding -23dBm . The fundamental EIRP was 24.0dBm so this harmonic was $24.0\text{dBm} - (-23) = 47\text{dBc}$.

6. MEASUREMENT UNCERTAINTY

Where relevant, the following test uncertainty levels have been estimated for tests performed on the EUT as specified in CISPR 16-4-2. This uncertainty represents an expanded uncertainty expressed at approximately the 95% confidence level using a coverage factor of $k = 2$.

Radiated Spurious Emission - AC1
Measuring Uncertainty for a Level of Confidence of 95% ($U=2Uc(y)$): $\pm 3.92\text{dB}$ (Below 30M)
Measuring Uncertainty for a Level of Confidence of 95% ($U=2Uc(y)$): $\pm 4.25\text{dB}$ (30M~1G)
Measuring Uncertainty for a Level of Confidence of 95% ($U=2Uc(y)$): $\pm 4.40\text{dB}$ (1G~18G)
Measuring Uncertainty for a Level of Confidence of 95% ($U=2Uc(y)$): $\pm 4.45\text{dB}$ (18G~40G)
Frequency Error
Measuring Uncertainty for a Level of Confidence of 95% ($U=2Uc(y)$): $\pm 78.4\text{Hz}$
Conducted Power
Measuring Uncertainty for a Level of Confidence of 95% ($U=2Uc(y)$): $\pm 0.84\text{dB}$
Conducted Spurious Emission
Measuring Uncertainty for a Level of Confidence of 95% ($U=2Uc(y)$): $\pm 2.65\text{ dB}$
Occupied Bandwidth
Measuring Uncertainty for a Level of Confidence of 95% ($U=2Uc(y)$): 3.3%
Temp. / Humidity
Measuring Uncertainty for a Level of Confidence of 95% ($U=2Uc(y)$): $\pm 0.82^\circ\text{C}$ / $\pm 3\%$
DC Voltage
Measuring Uncertainty for a Level of Confidence of 95% ($U=2Uc(y)$): $\pm 0.3\%$

7. TEST RESULT

7.1. Summary

FCC Classification: **PCS Licensed Transmitter (PCB)**

Mode(s): **LTE Band 26**

FCC Part Section(s)	ISED Standard	Test Description	Test Limit	Test Condition	Test Result	Reference
2.1049	RSS-GEN 6.7	Occupied bandwidth	N/A	Conducted	Pass	Section 7.2
2.1051 90.543 (Band14)	RSS-GEN 6.6, RSS-140 4.4 (Band14)	Conducted Spurious Emissions	<-13dBm		Pass	Section 7.3
90.691 (Band26)	NA		<-13dBm			
2.1051 90.543 (Band14)	RSS-GEN 6.6, RSS-140 4.4 (Band14)	Band Edge	<-13dBm <-35dBm for 769-775MHz and 799-805MHz		Pass	Section 7.4
90.691 (Band26)	NA		<-20dBm for less than 37.5 kHz <-13dBm for greater than 37.5 kHz			
2.1046 90.542 (Band14)	RSS-GEN 6.12, RSS-140 4.3 (Band14)	Conducted Output Power	N/A		Pass	Section 7.5
90.635 (Band26)	NA		< 3 Watts max. ERP (Band 14) < 100 Watts max. ERP (Band 26)			

2.1051 90.543 (Band14)	RSS-GEN 6.6, RSS-140 4.4 (Band14)	Radiated Spurious Emissions	<-13dBm <-40dBm for 1559-1610MHz	Radiated	Pass	Section 7.5
90.691 (Band26)	NA		<-13dBm			
24.232(d)	RSS-GEN 6.12, RSS-140 4.3 (Band14)	Peak-Average Ratio	<13dB	Conducted	Pass	Section 7.6
2.1055 90.213	RSS-GEN 8.11, RSS-140 4.2 (Band14)	Frequency Stability	< 2.5 ppm		Pass	Section 7.7

Notes:

- 1) Determining compliance is based on the test results met the regulation limits or requirements declared by clients, and the test results don't take into account the value of measurement uncertainty.
- 2) All modes of operation and data rates were investigated. The test results shown in the following sections represent the worst case emissions.
- 3) All antenna port conducted emissions testing was performed on a test bench with the antenna port of the EUT connected to the spectrum analyzer through calibrated cables, attenuators, and couplers.

7.2. Occupied Bandwidth

7.2.1. Test Limit

N/A

7.2.2. Test Procedure used

KDB 971168 D01v02r02 – Section 4.2 & ANSI/TIA-603-E-2016

7.2.3. Test Setting

1. The spectrum analyzer center frequency is set to the nominal EUT channel center frequency. The span range for the spectrum analyzer shall be between two and five times the anticipated OBW.
2. The nominal resolution bandwidth (RBW) shall be in the range of 1 to 5 % of the anticipated OBW, and the VBW shall be at least 3 times the RBW. (RBW = approximately 1% of the emission bandwidth).
3. Set the detection mode to peak, and the trace mode to max hold.
4. Use the 99 % power bandwidth function of the spectrum analyzer (if available) and report the measured bandwidth.

7.2.4. Test Setup

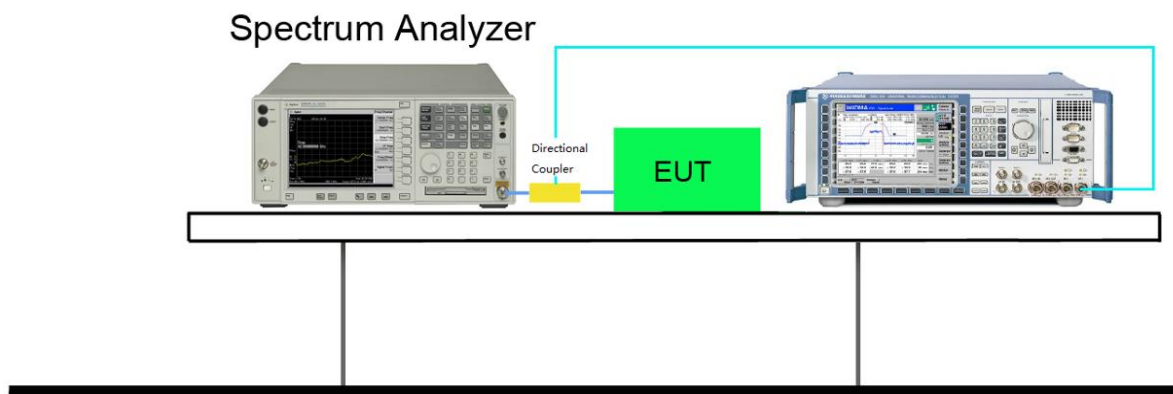

7.2.5. Test Result

Test Mode	Channel/ Frequency (MHz)	Modulation	Bandwidth (MHz)	RB Size	RB Offset	99% Occupied Bandwidth (MHz)	-26dB Occupied Bandwidth (MHz)	Test Result
LTE Band 26	CH26740 (819MHz)	QPSK	1.4	6	0	1.0803	1.232	Pass
			3	15	0	2.6845	2.910	Pass
			5	25	0	4.4639	4.865	Pass
			10	50	0	8.9534	9.620	Pass
		16QAM	1.4	6	0	1.0784	1.227	Pass
			3	15	0	2.6767	2.905	Pass
			5	25	0	4.4707	4.894	Pass
			10	50	0	8.9463	9.556	Pass



LTE Band 26 16QAM 1.4MHz CH26740 6RB#0

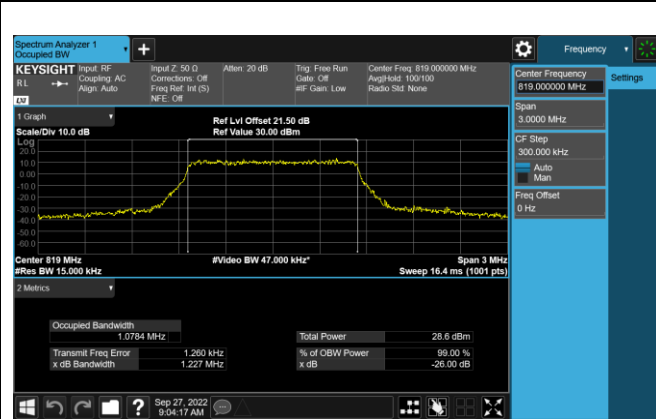

LTE Band 26 16QAM 3MHz CH26740 15RB#0

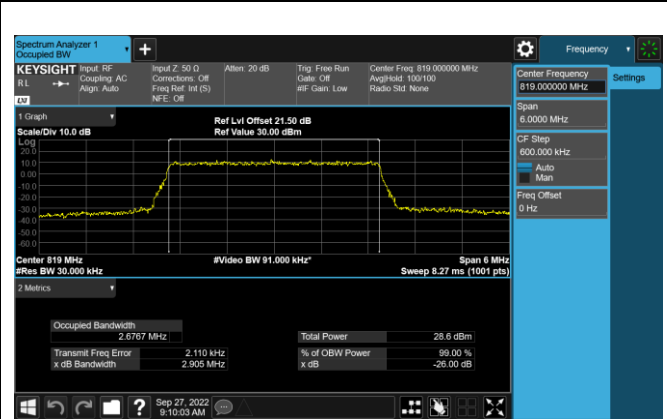

LTE Band 26 16QAM 5MHz CH26740 25RB#0

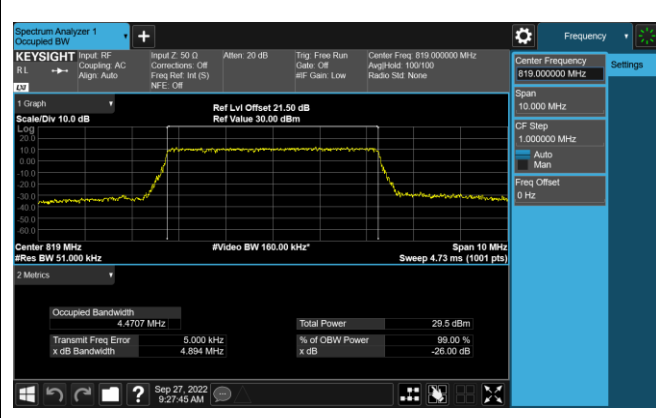

LTE Band 26 16QAM 10MHz CH26740 50RB#0

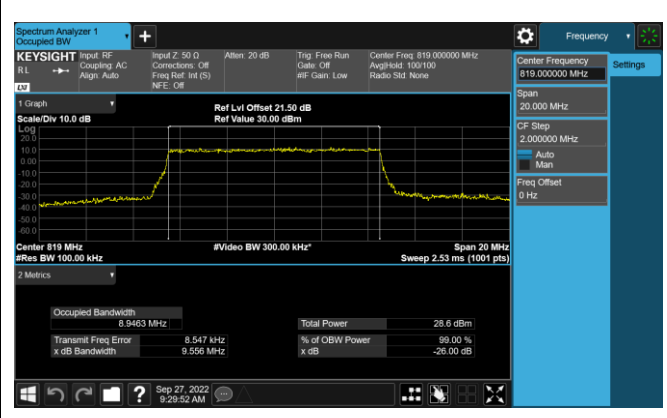

7.3. Conducted Spurious Emissions

7.3.1. Test Limit

The power of any emission outside of the authorized operating frequency ranges must be attenuated below the transmitting power (P) by a factor of at least $43 + 10\log_{10}(P)$ dB for Band 14, 26.

7.3.2. Test Procedure Used

KDB 971168 D01v02r02 – Section 6.0 & ANSI/TIA-603-E-2016

7.3.3. Test Setting

Compliance with these rules is based on the use of measurement instrumentation employing a resolution bandwidth of 100 kHz is at or below 1GHz and 1MHz is above 1GHz, if any, up to 10th harmonic.

7.3.4. Test Setup

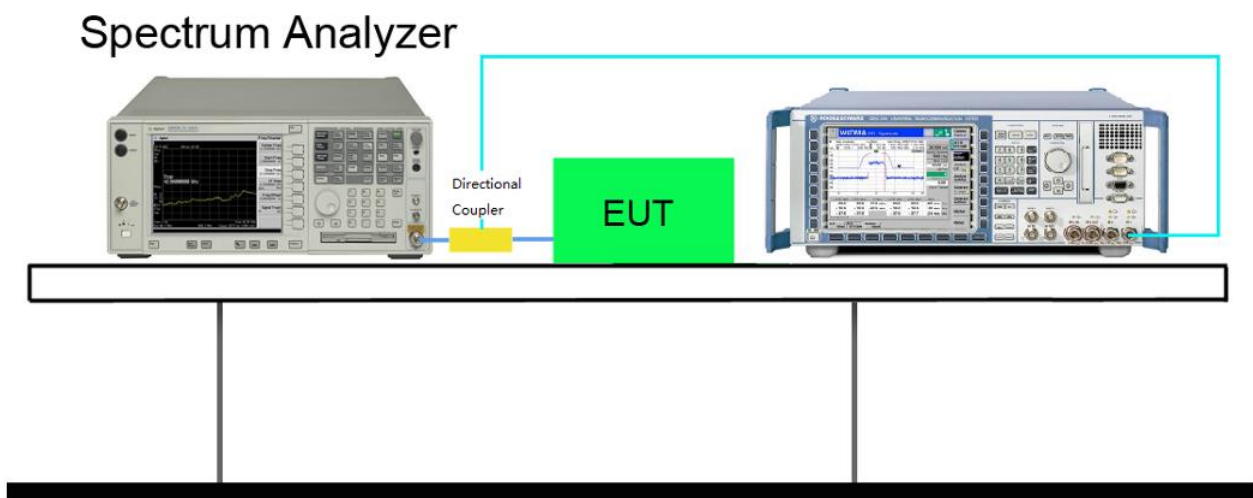

7.3.5. Test Result

Test Mode			LTE Band 26			
Modulation	Channel	Frequency (MHz)	Bandwidth (MHz)	RB Size	RB Offset	Test Result
QPSK & 16QAM	26697	814.7	1.4M	1	2	Pass
	26740	819	1.4M	1	2	Pass
	26783	823.3	1.4M	1	2	Pass
	26705	815.5	3M	1	7	Pass
	26740	819	3M	1	7	Pass
	26775	822.5	3M	1	7	Pass
	26715	816.5	5M	1	12	Pass
	26740	819	5M	1	12	Pass
	26765	821.5	5M	1	12	Pass
	26740	819	10M	1	25	Pass

LTE Band 26 QPSK 1.4MHz CH26697 1RB#2_30MHz-1GHz



LTE Band 26 QPSK 1.4MHz CH26697 1RB#2_1GHz-10GHz

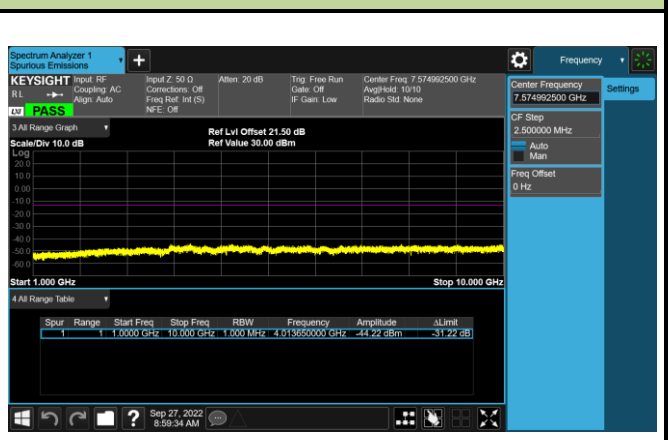

LTE Band 26 QPSK 1.4MHz CH26740 1RB#2_30MHz-1GHz

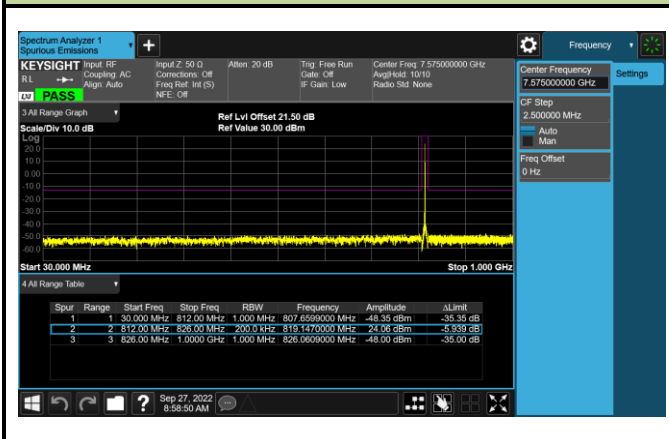

LTE Band 26 QPSK 1.4MHz CH26740 1RB#2_1GHz-10GHz

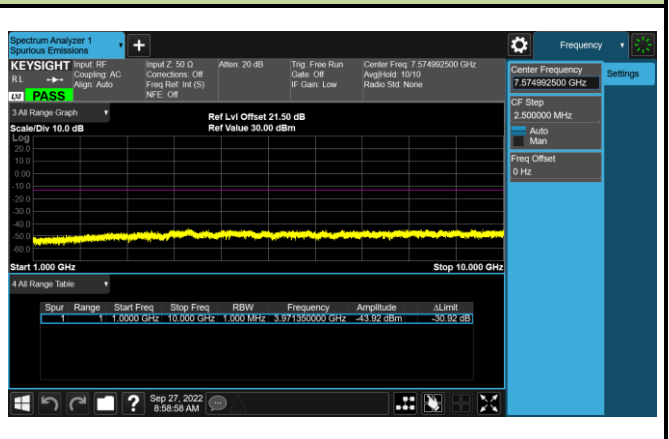

LTE Band 26 QPSK 1.4MHz CH26783 1RB#2_30MHz-1GHz

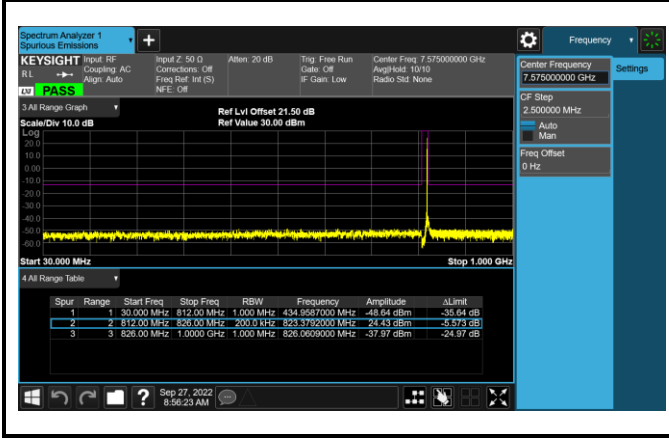

LTE Band 26 QPSK 1.4MHz CH26783 1RB#2_1GHz-10GHz

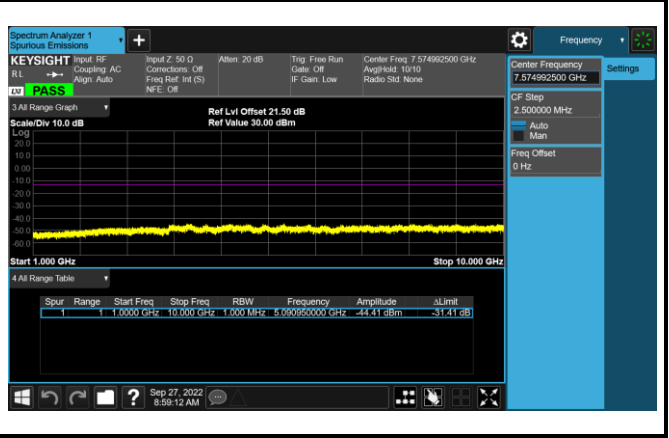

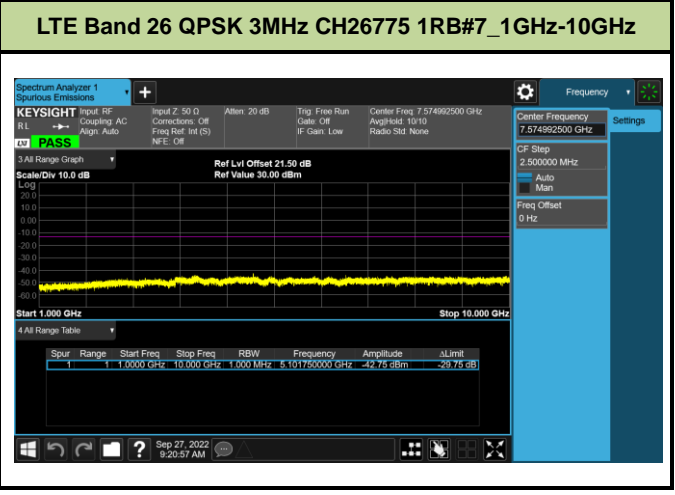
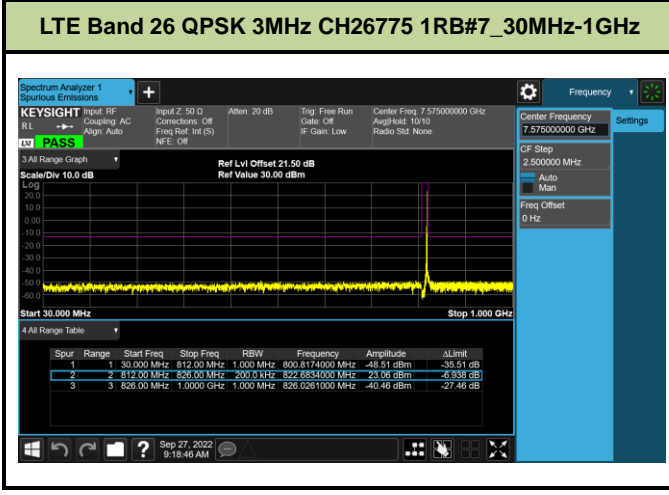
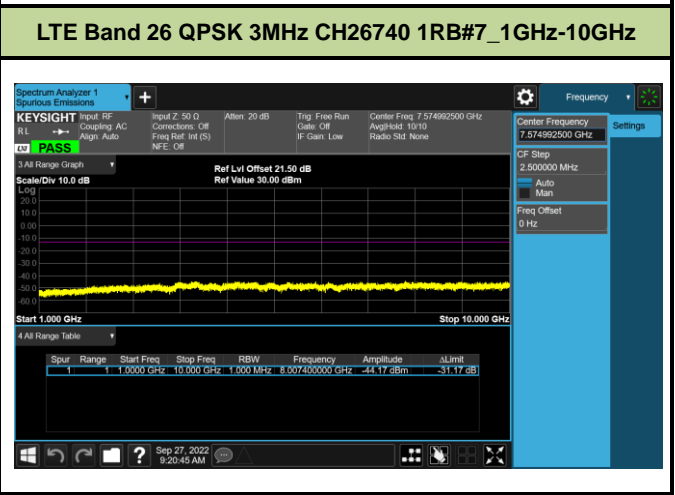
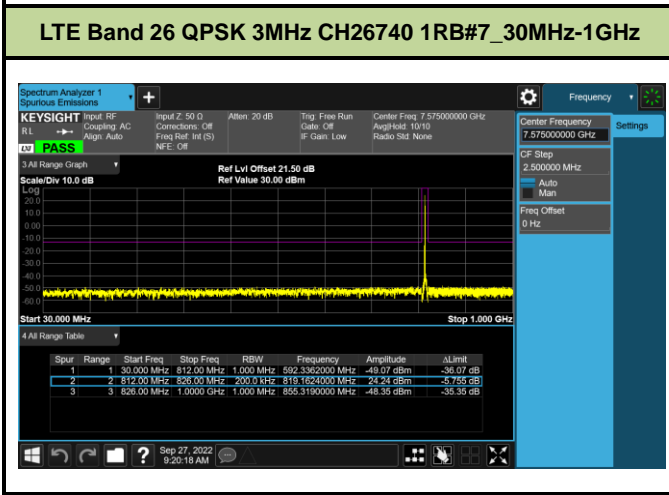
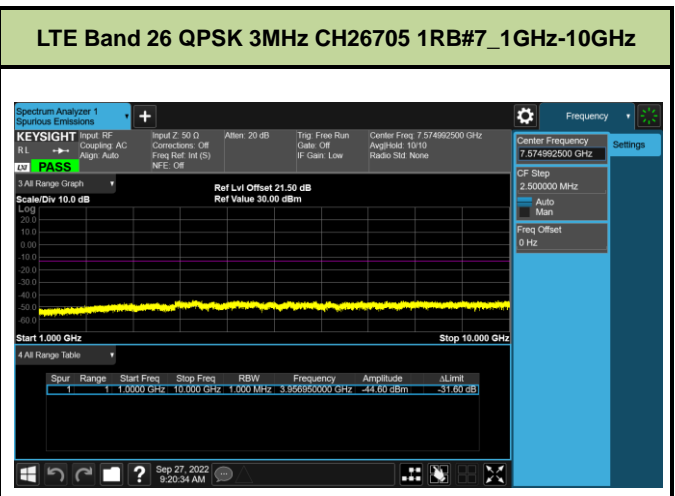
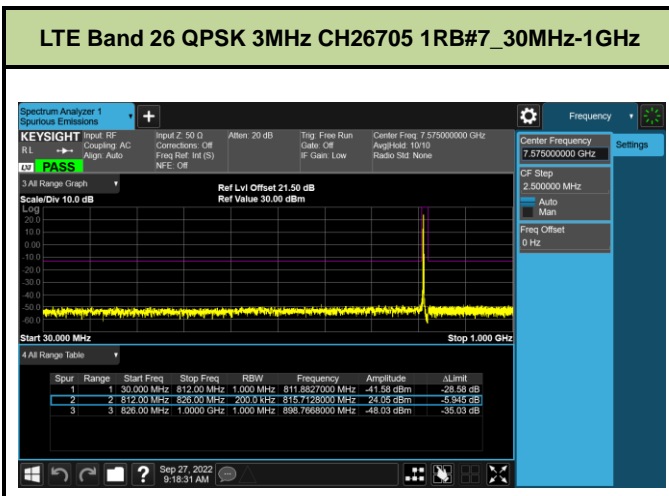

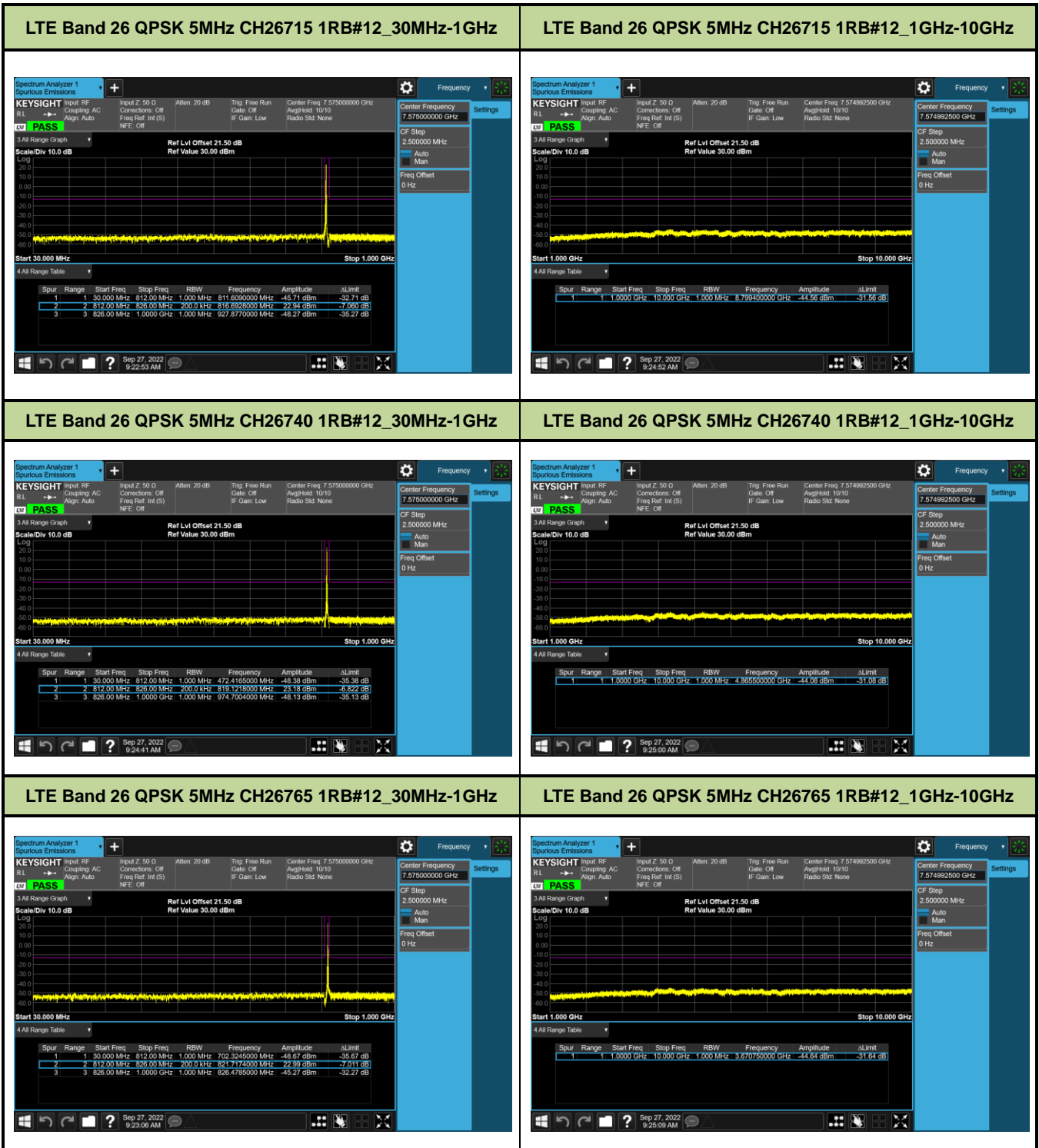

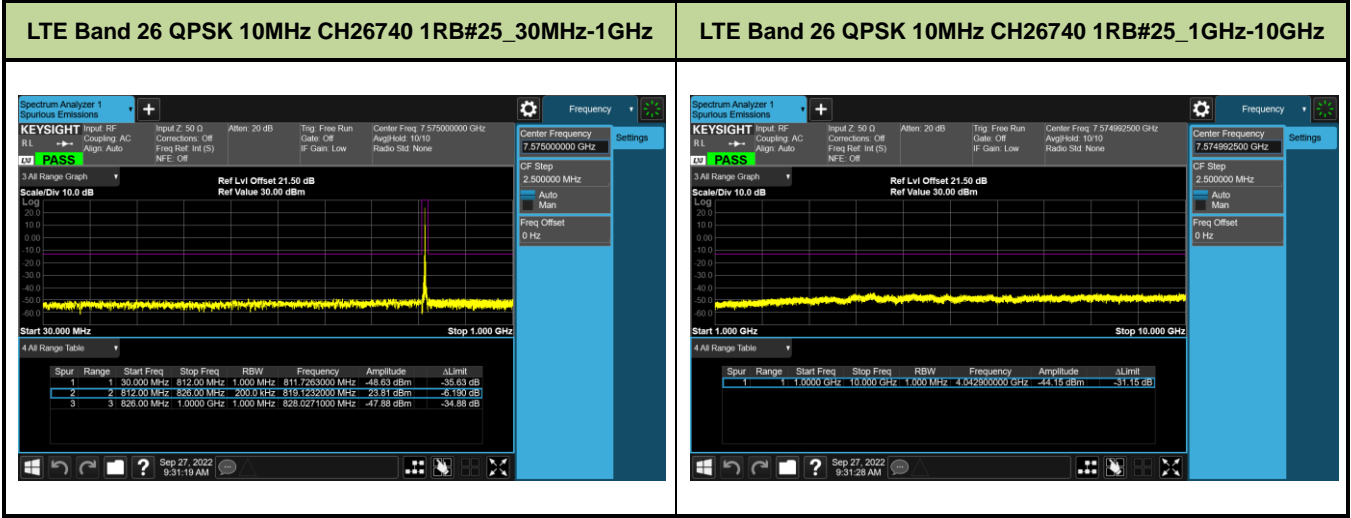

LTE Band 26 16QAM 1.4MHz CH26697 1RB#2_30MHz-1GHz

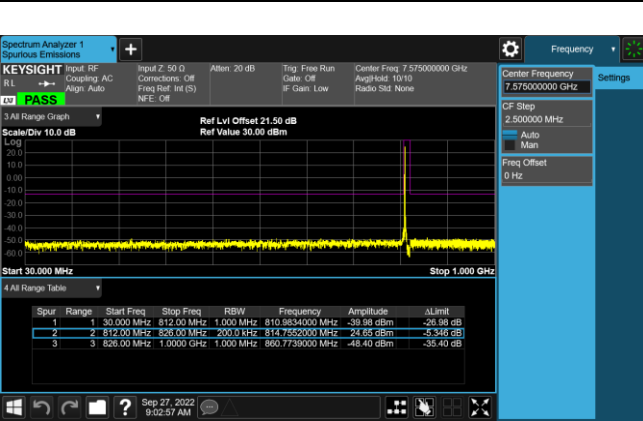

LTE Band 26 16QAM 1.4MHz CH26697 1RB#2_1GHz-10GHz

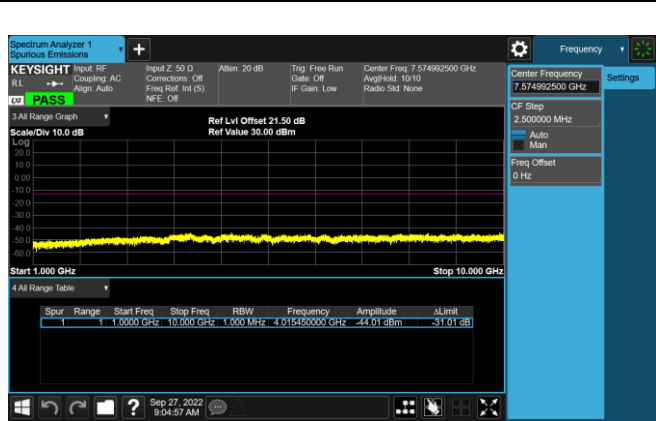

LTE Band 26 16QAM 1.4MHz CH26740 1RB#2_30MHz-1GHz

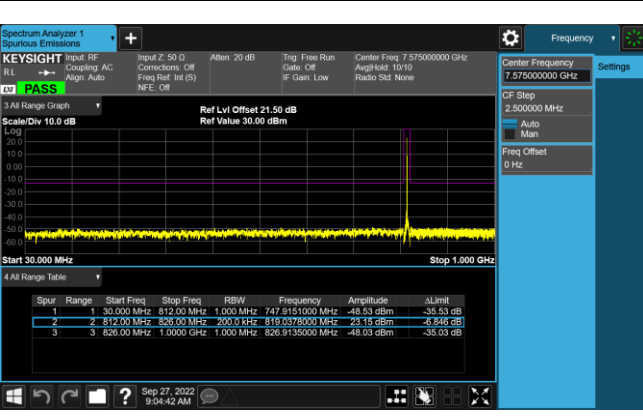

LTE Band 26 16QAM 1.4MHz CH26740 1RB#2_1GHz-10GHz

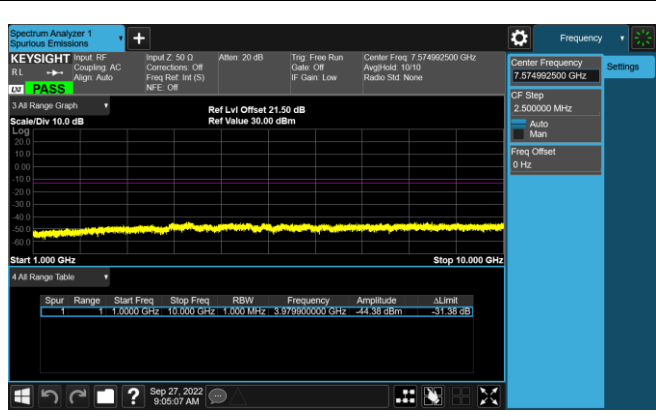

LTE Band 26 16QAM 1.4MHz CH26783 1RB#2_30MHz-1GHz

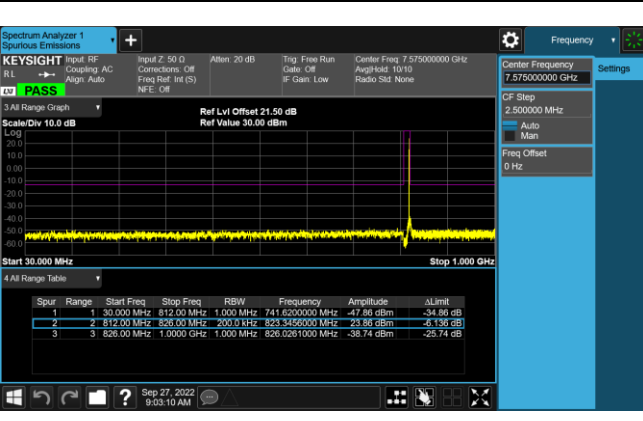

LTE Band 26 16QAM 1.4MHz CH26783 1RB#2_1GHz-10GHz

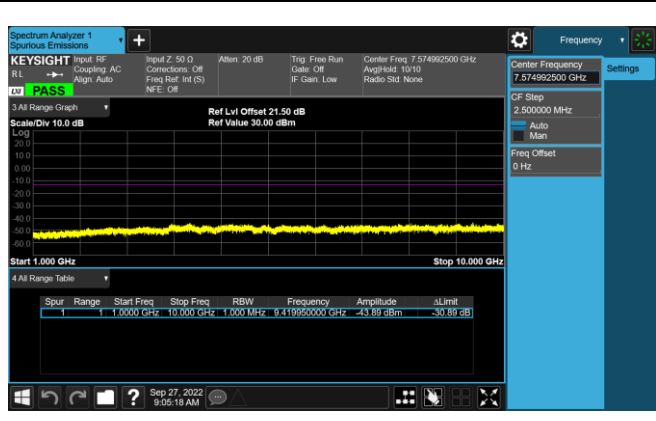

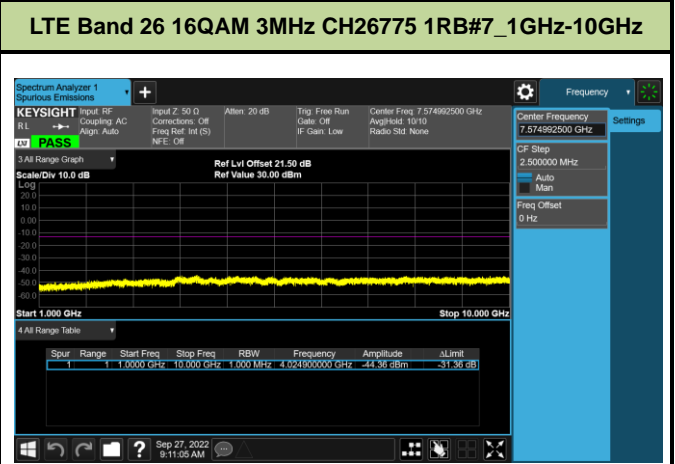
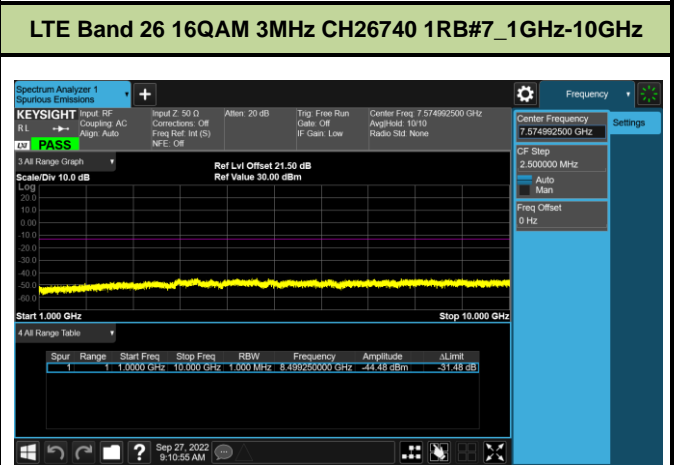
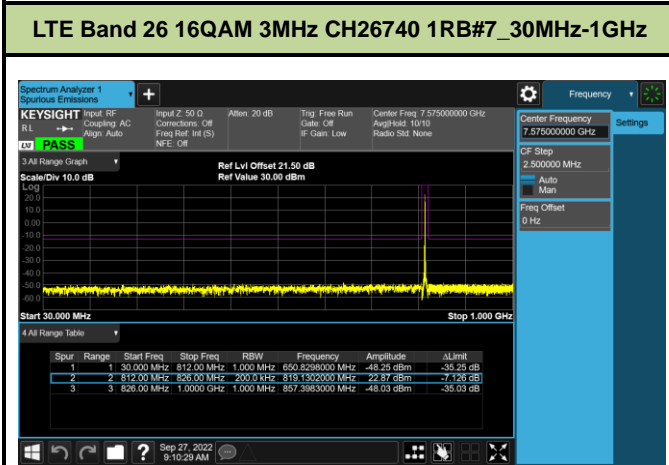
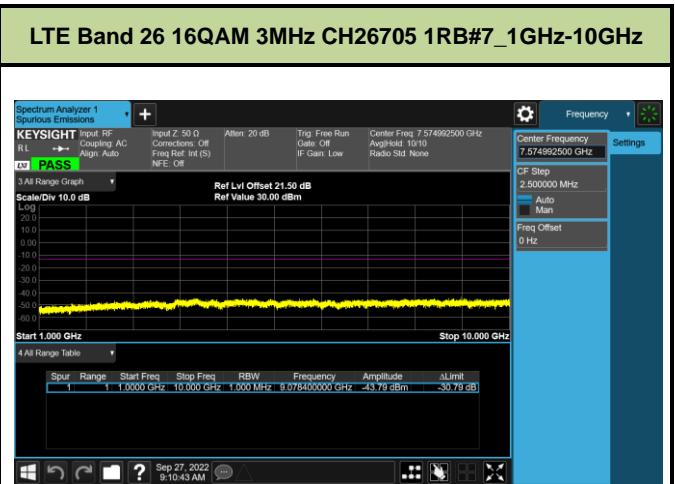
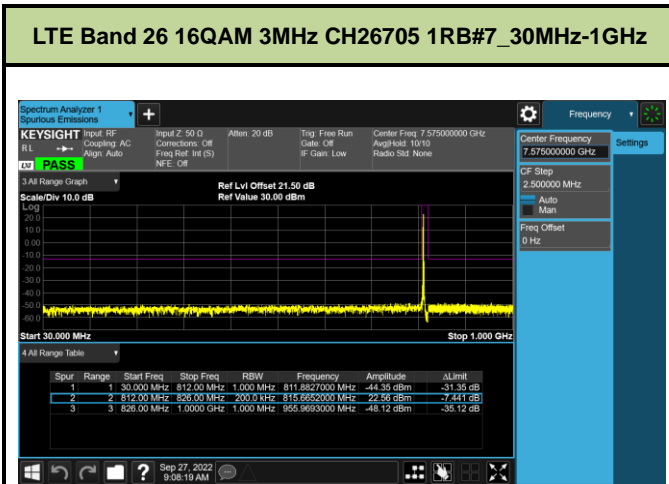

LTE Band 26 16QAM 5MHz CH26715 1RB#12_30MHz-1GHz

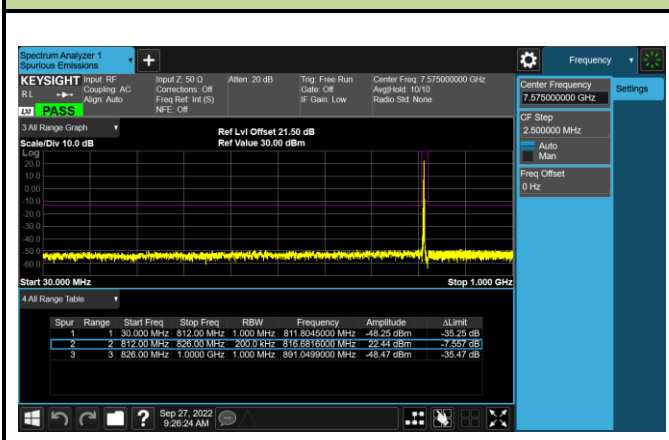

LTE Band 26 16QAM 5MHz CH26715 1RB#12_1GHz-10GHz



LTE Band 26 16QAM 5MHz CH26740 1RB#12_30MHz-1GHz

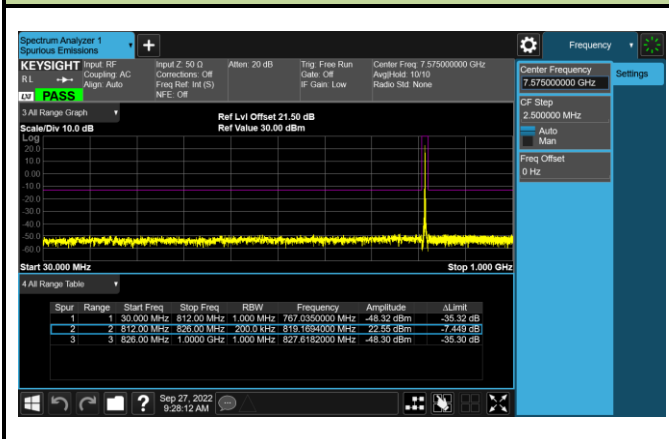

LTE Band 26 16QAM 5MHz CH26740 1RB#12_1GHz-10GHz



LTE Band 26 16QAM 5MHz CH26765 1RB#12_30MHz-1GHz

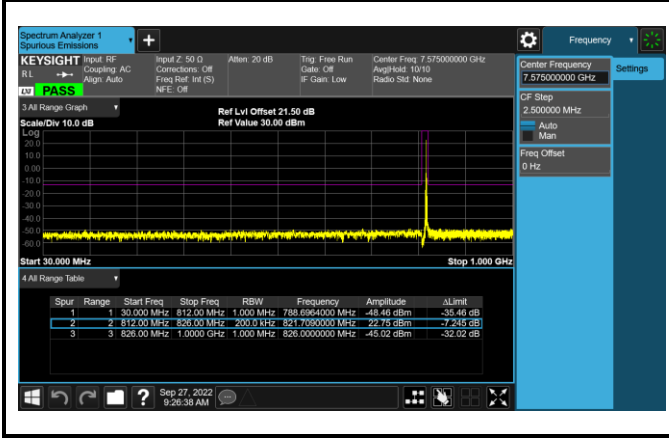

LTE Band 26 16QAM 5MHz CH26765 1RB#12_1GHz-10GHz

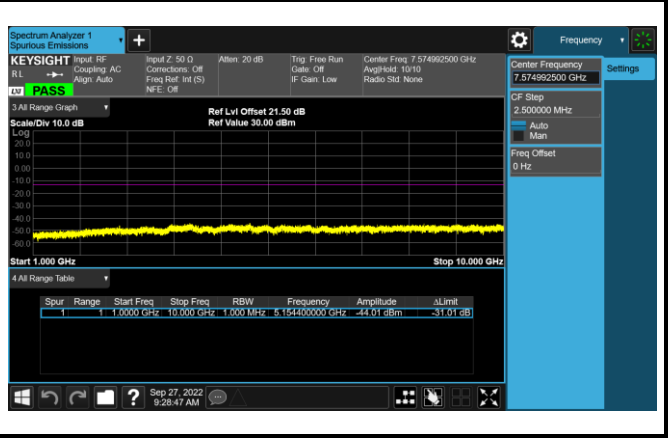

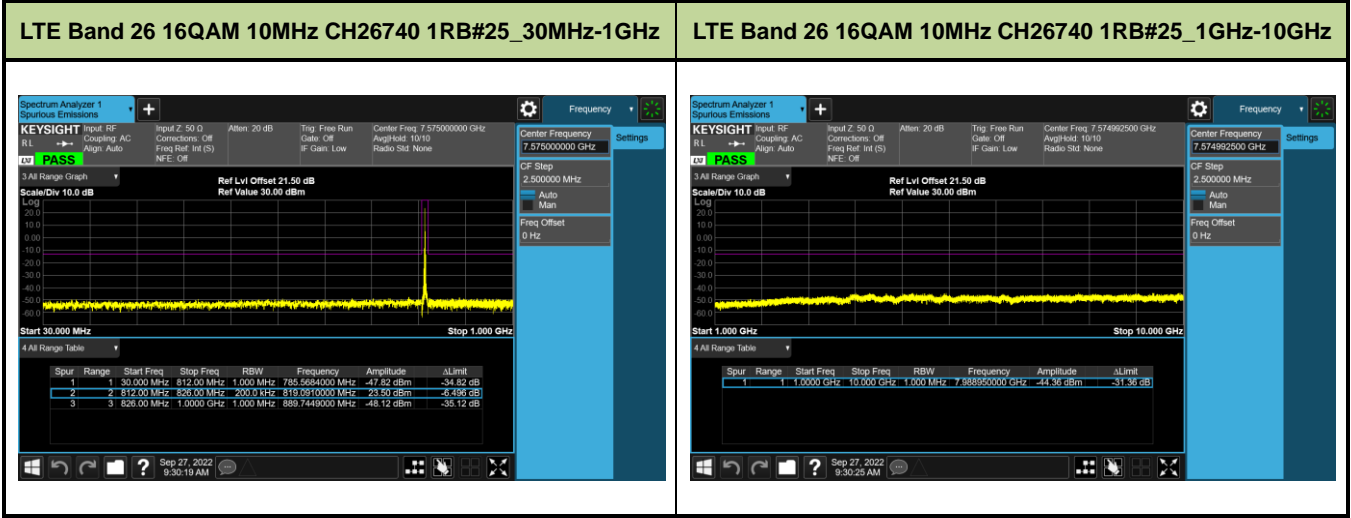

7.4. Band Edge at Antenna Terminal

7.4.1. Test Limit

For LTE Band 14:

The spurious (unwanted) emission limits specified in the individual FCC rule parts applicable to licensed digital transmitters (typically referred to under the heading 'emission limits') normally apply to any and all emissions that are present outside of the authorized frequency band/block and apply to emissions in both the out-of-band and spurious domains. unwanted emissions are required by the licensed rule parts to be attenuated below the transmitter power by a factor of at least $43 + 10\log(P)$ dB on any frequency between 775-788 MHz, above 805 MHz, and below 758 MHz, where P represents the transmitter power expressed in watts.

In accordance with Part 90.543 (e)(3) of this section is based on the use of measurement instrumentation employing a resolution bandwidth of 100 kHz or greater. However, in the 100 kHz bands immediately outside and adjacent to the frequency block, a resolution bandwidth of 30 kHz may be employed.

On all frequencies between 769-775 MHz and 799-805 MHz, by a factor not less than $65 + 10 \log (P)$ dB in a 6.25 kHz band segment, for mobile and portable stations

For LTE Band 26:

(1) For any frequency removed from the EA licensee's frequency block by up to and including 37.5 kHz, the power of any emission shall be attenuated below the transmitter power (P) in watts by at least $116 \log_{10}(f/6.1)$ decibels or $50 + 10 \log_{10}(P)$ decibels or 80 decibels, whichever is the lesser attenuation, where f is the frequency removed from the center of the outer channel in the block in kilohertz and where f is greater than 12.5 kHz.

(2) For any frequency removed from the EA licensee's frequency block greater than 37.5 kHz, the power of any emission shall be attenuated below the transmitter power (P) in watts by at least $43 + 10 \log_{10}(P)$ decibels or 80 decibels, whichever is the lesser attenuation, where f is the frequency removed from the center of the outer channel in the block in kilohertz and where f is greater than 37.5 kHz.

7.4.2. Test Procedure Used

KDB 971168 D01v02r02 – Section 6.0 & ANSI/TIA-603-E-2016

7.4.3. Test Setting

In the 1 MHz bands immediately outside and adjacent to the frequency block a resolution bandwidth of at least one percent of the emission bandwidth of the fundamental emission of the transmitter may be employed. A narrower resolution bandwidth is permitted in all cases to improve measurement accuracy provided the measured power is integrated over the full required measurement bandwidth (i.e. 100 kHz or 1 percent of emission bandwidth, as specified). The emission bandwidth is defined as the width of the signal between two points, one below the carrier center frequency and one above the carrier center frequency, outside of which all emissions are attenuated at least 26 dB below the transmitter power.

7.4.4. Test Setup

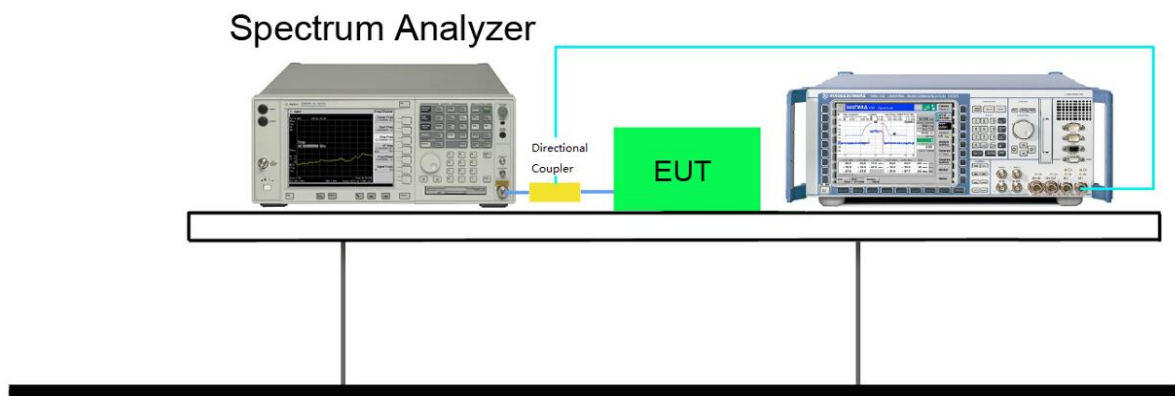

7.4.5. Test Result

Test Mode			LTE Band 26			
Modulation	Channel	Frequency (MHz)	Bandwidth (MHz)	RB Size	RB Offset	Test Result
QPSK & 16QAM	26697	814.7	1.4M	1	0	Pass
	26783	823.3	1.4M	1	5	Pass
	26697	814.7	1.4M	6	0	Pass
	26783	823.3	1.4M	6	0	Pass
	26705	815.5	3M	1	0	Pass
	26775	822.5	3M	1	14	Pass
	26705	815.5	3M	15	0	Pass
	26775	822.5	3M	15	0	Pass
	26715	816.5	5M	1	0	Pass
	26765	821.5	5M	1	24	Pass
	26715	816.5	5M	25	0	Pass
	26765	821.5	5M	25	0	Pass
	26740	819	10M	1	0	Pass
	26740	819	10M	1	49	Pass
	26740	819	10M	50	0	Pass

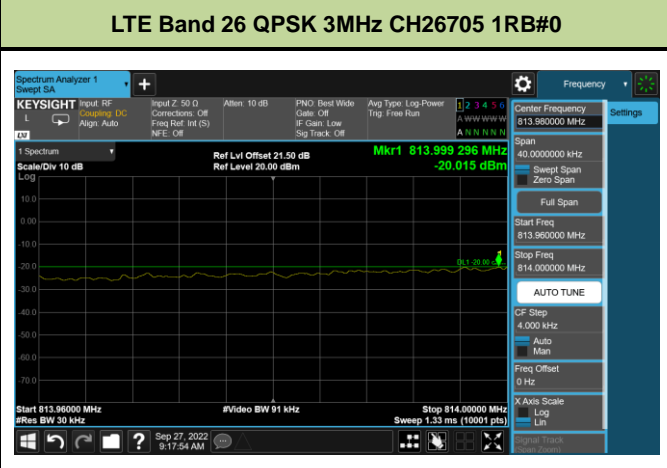
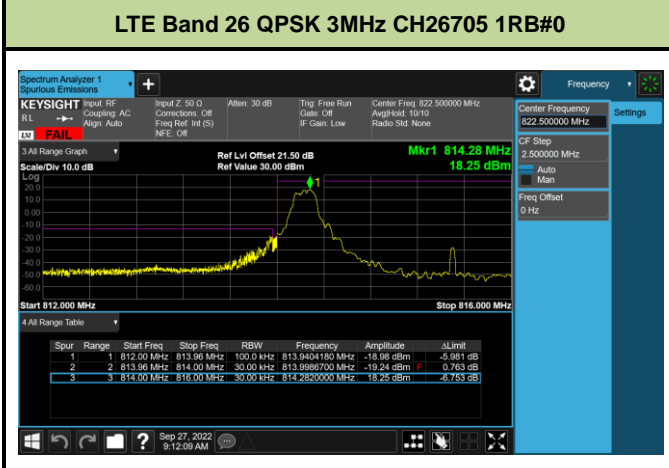
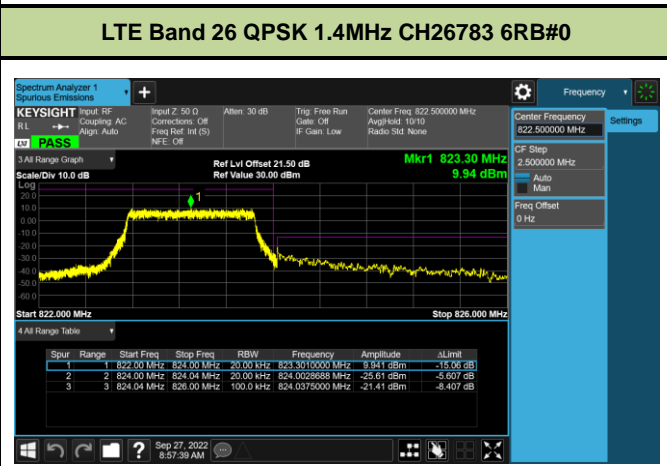
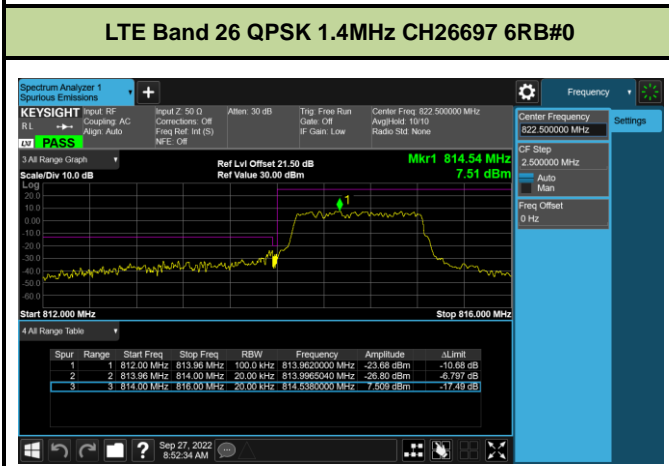
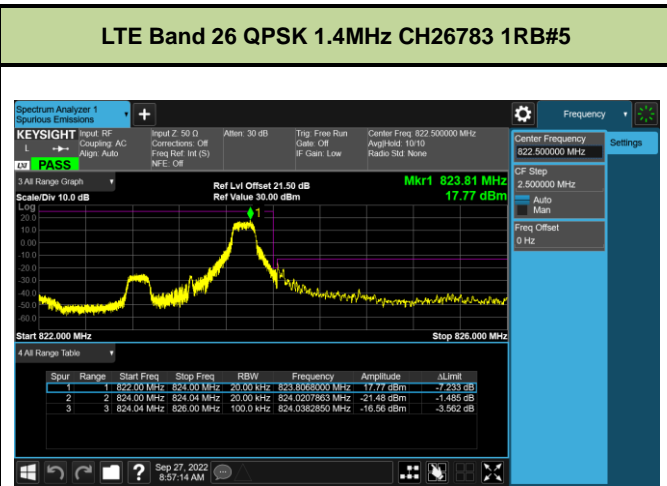
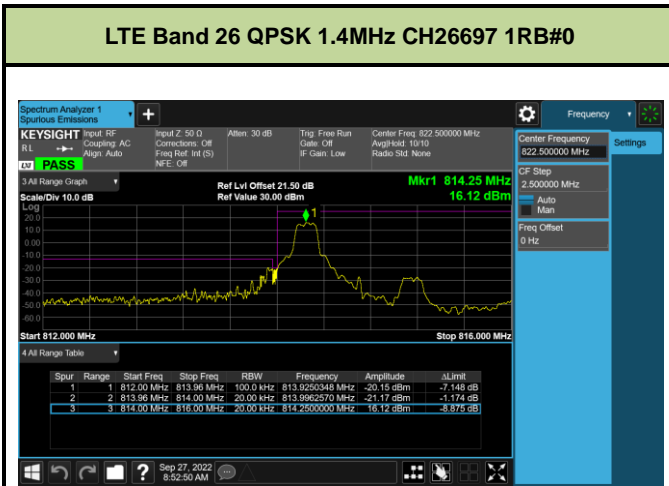

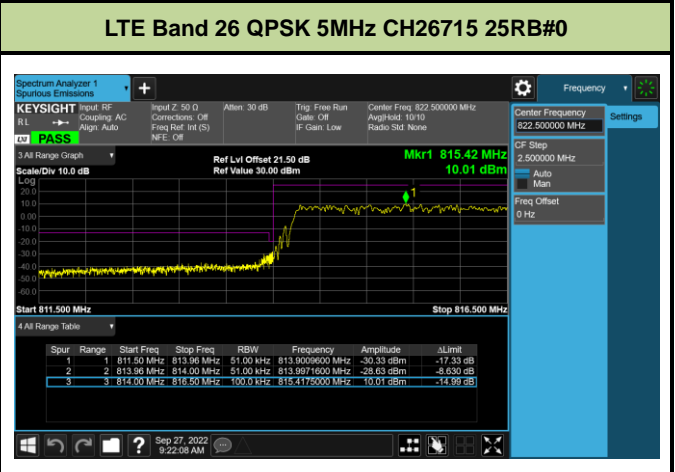
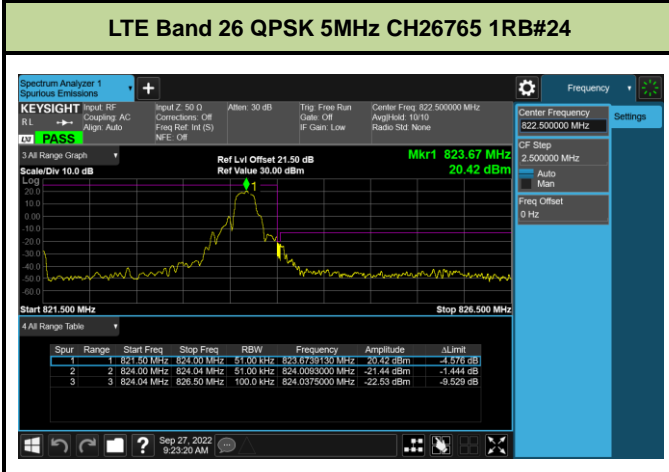
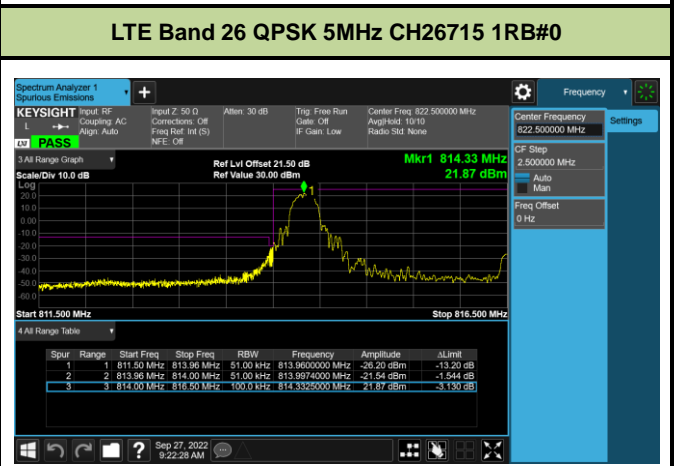
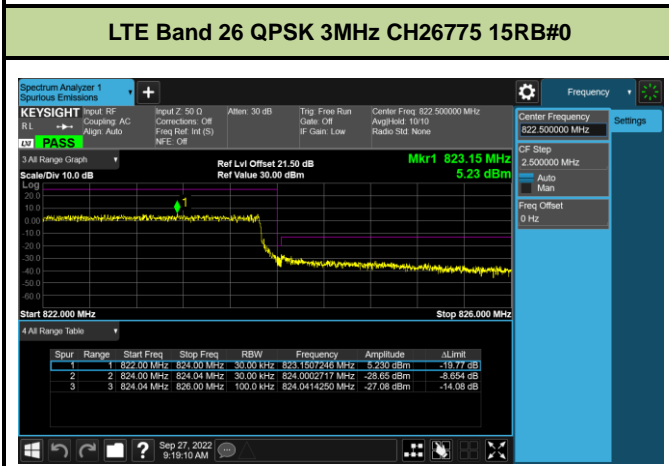
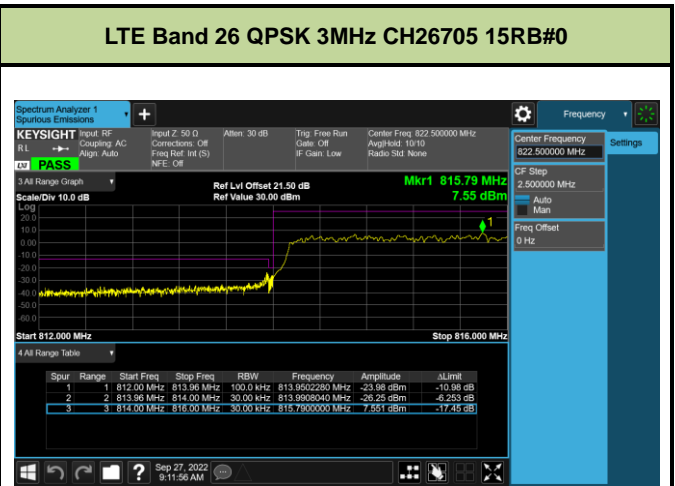
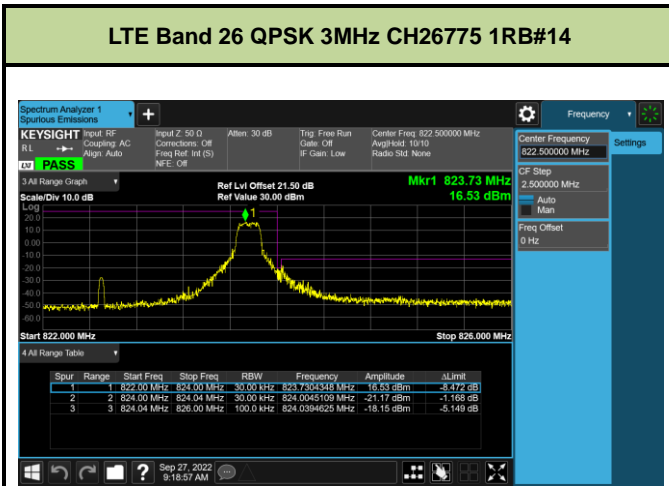

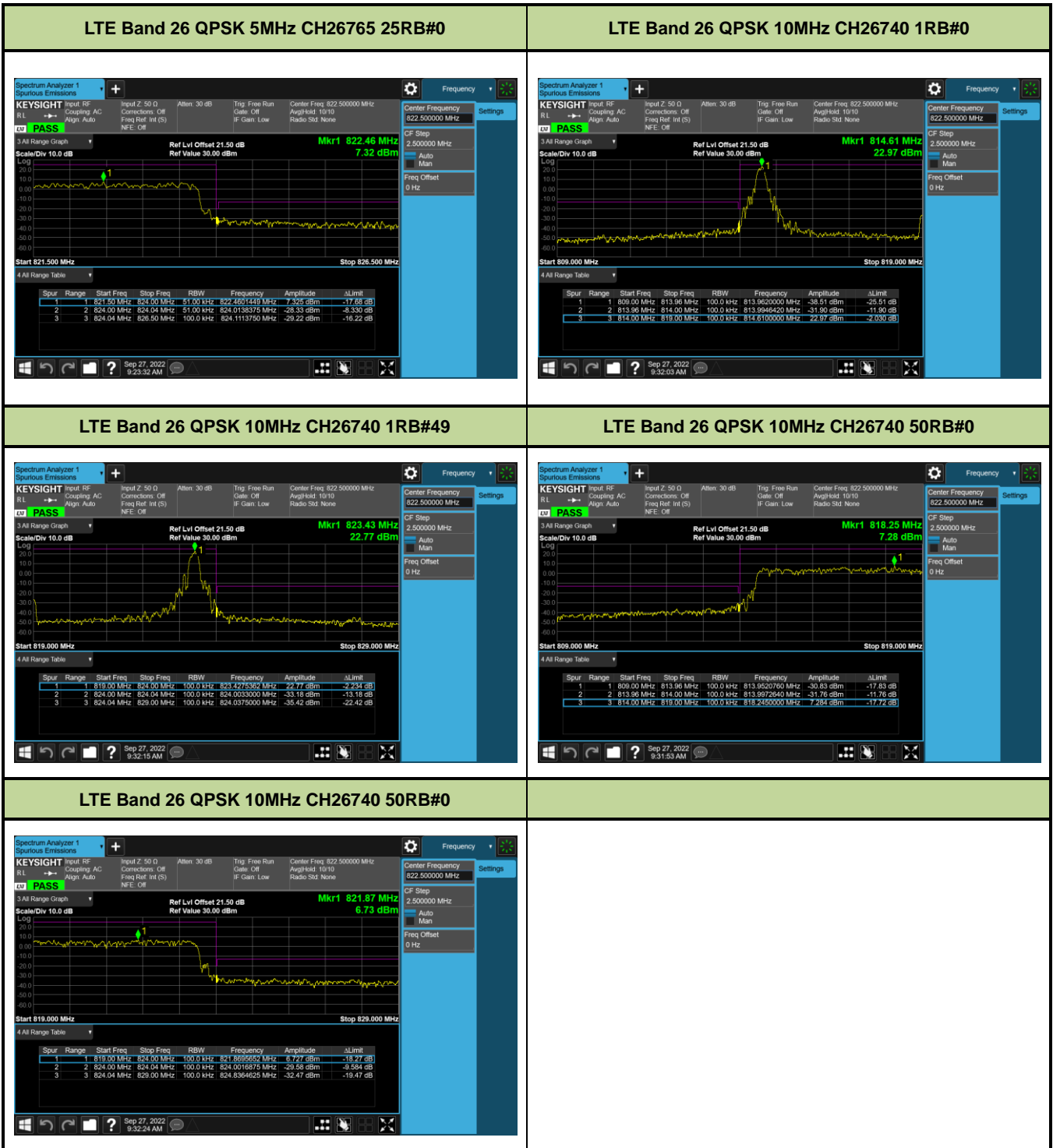

LTE Band 26 16QAM 1.4MHz CH26697 1RB#0

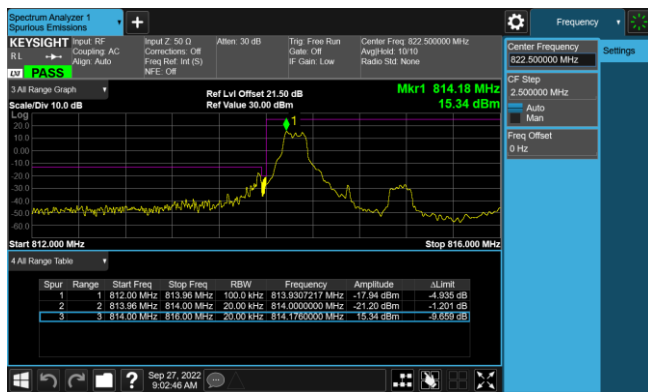

LTE Band 26 16QAM 1.4MHz CH26783 1RB#5

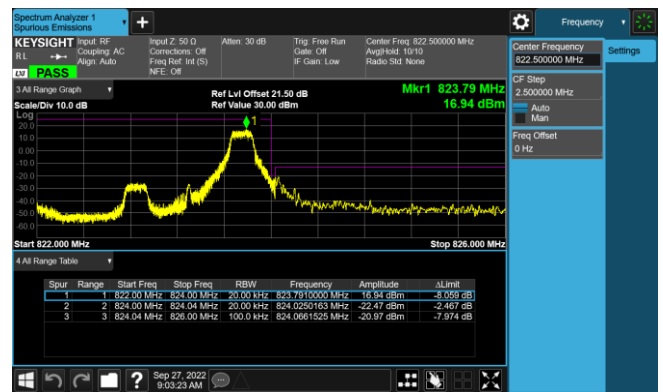

LTE Band 26 16QAM 1.4MHz CH26697 6RB#0

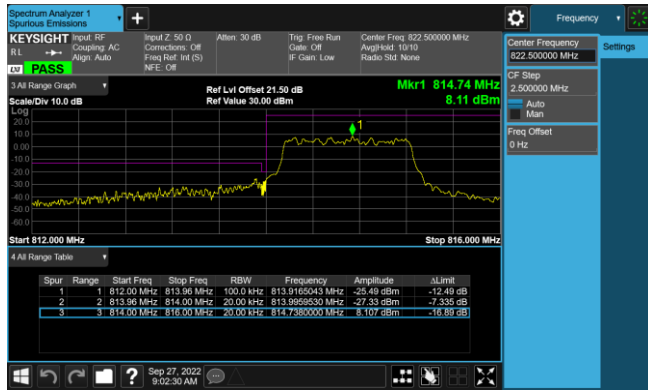

LTE Band 26 16QAM 1.4MHz CH26783 6RB#0

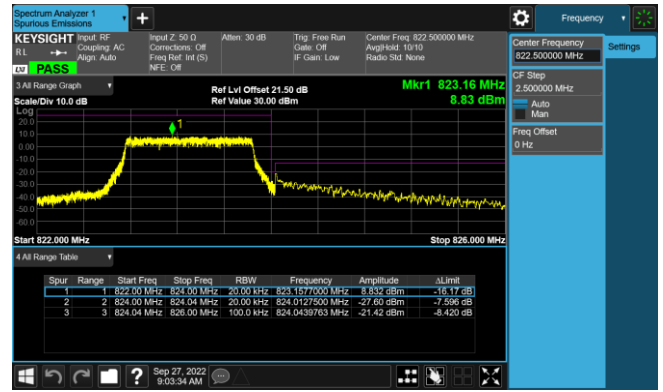

LTE Band 26 16QAM 3MHz CH26705 1RB#0

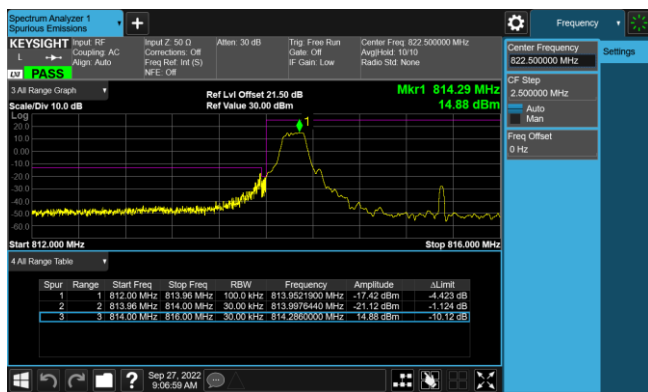

LTE Band 26 16QAM 3MHz CH26775 1RB#14

