



Actuator LA36 I/O  
User manual

# Contents

Preface .....	3
LINAK application policy.....	4
<b>Chapter 1</b>	
Safety instructions.....	5
Warnings .....	6
<b>Chapter 2</b>	
Mounting of cables .....	9
<b>Chapter 3</b>	
Troubleshooting .....	13
Troubleshooting for Parallel.....	15
<b>Chapter 4</b>	
Specifications .....	17
Usage .....	17
Actuator dimensions.....	18
Built-in dimensions.....	19
Manual Hand Crank .....	20
24 V motor .....	21
48 V motor .....	22
Label for LA36 .....	23
Key to symbols .....	24
<b>Chapter 5</b>	
Maintenance.....	27
Repair .....	27
Main groups of disposal .....	27
Warranty.....	27
Declaration of conformity .....	28
Declaration of incorporation of partly completed machinery.....	32
<b>Chapter 6</b>	
IECEX/ATEX.....	33
Warnings .....	33
General indication of risk:.....	34
Mounting of ATEX cables .....	34

## **Preface**

Dear User,

We are delighted that you have chosen a product from LINAK®.

LINAK systems are high-tech products based on many years of experience in the manufacture and development of actuators, electric control boxes, controls, and chargers.

This user manual does not address the end-user, but is intended as a source of information for the manufacturer of the equipment or system only, and it will tell you how to install, use and maintain your LINAK electronics. It is the responsibility of the manufacturer of the end-use product to provide a User Manual where relevant safety information from this manual is passed on to the end-user.

We are sure that your LINAK product/system will give you many years of problem-free operation. Before our products leave the factory they undergo full function and quality testing. Should you nevertheless experience problems with your LINAK product/system, you are always welcome to contact your local dealer. LINAK subsidiaries and some distributors situated all over the world have authorised service centres, which are always ready to help you.

LINAK provides a warranty on all its products. This warranty, however, is subject to correct use in accordance with the specifications, maintenance being done correctly and any repairs being carried out at a service centre, which is authorised to repair LINAK products.

Changes in installation and use of LINAK products/systems can affect their operation and durability. The products are not to be opened by unauthorised personnel.

The User Manual has been written based on our present technical knowledge. We are constantly working on updating the information and we therefore reserve the right to carry out technical modifications.

**LINAK A/S**

## **LINAK application policy**

The purpose of the application policy is to define areas of responsibilities in relation to applying a LINAK product defined as hardware, software, technical advice, etc. related to an existing or a new customer application.

LINAK products as defined above are applicable for a wide range of applications within Medical, Furniture, Desk, and Industry areas. Yet, LINAK cannot know all the conditions under which LINAK products will be installed, used, and operated, as each individual application is unique.

The suitability and functionality of the LINAK product and its performance under varying conditions (application, vibration, load, humidity, temperature, frequency, etc.) can only be verified by testing, and shall ultimately be the responsibility of the LINAK customer using any LINAK product.

LINAK shall be responsible solely that LINAK products comply with the specifications set out by LINAK and it shall be the responsibility of the LINAK customer to ensure that the specific LINAK product can be used for the application in question.

# Chapter 1



## Safety instructions

Please read this safety information carefully:

Be aware of the following three symbols throughout the user manual:

### Warning!

Failing to follow these instructions can cause accidents resulting in serious personal injury.



### Recommendations

Failing to follow these instructions can result in the actuator suffering damage or being ruined.



### Additional information

Usage tips or additional information that is important in connection with the use of the actuator.



Furthermore, ensure that all staff who are to connect, mount, or use the actuator are in possession of the necessary information and that they have access to this user manual.

Persons who do not have the necessary experience or knowledge of the product/products must not use the product/products. Besides, persons with reduced physical or mental abilities must not use the product/products, unless they are under surveillance or they have been thoroughly instructed in the use of the apparatus by a person who is responsible for the safety of these persons.

Moreover, children must be under surveillance to ensure that they do not play with the product.

### Before you start mounting/dismounting, ensure that the following points are observed:

- The actuator is not in operation.
- The actuator is free from loads that could be released during this work.

### Before you put the actuator into operation, check the following:

- The actuator is correctly mounted as indicated in the relevant user instructions.
- The equipment can be freely moved over the actuator's whole working area.
- The actuator is connected to a mains electricity supply/transformer with the correct voltage and which is dimensioned and adapted to the actuator in question.
- Ensure that the voltage applied matches to the voltage specified on the actuator label.
- Ensure that the connection bolts can withstand the wear.
- Ensure that the connection bolts are secured safely.

**During operation, please be aware of the following:**

- Listen for unusual sounds and watch out for uneven running. Stop the actuator immediately if anything unusual is observed.
- Do not sideload the actuator.
- Only use the actuator within the specified working limits.
- Do not step or kick on the actuator.

**When the equipment is not in use:**

- Switch off the mains supply in order to prevent unintentional operation.
- Check regularly for extraordinary wear.

**Classification**

The equipment is not suitable for use in the presence of a flammable anaesthetic mixture with air or with oxygen or nitrous oxide.

**Warnings**

- Do not sideload the actuator.
- When mounting the LA36 in the application ensure that the bolts can withstand the wear and that they are secured safely.
- If irregularities are observed, the actuator must be replaced.

**Recommendations**

- Do not place load on the actuator housing and do prevent impact or blows, or any other form of stress to the housing.
- Ensure that the cable cover is mounted correctly. Use 3.5 Nm torque.
- Ensure that the duty cycle and the usage temperatures for LA36 actuators are respected.
- Ensure that the cable cannot be squeezed, pulled or subjected to any other stress.
- Furthermore, it will be good practice to ensure that the actuator is fully retracted in the "normal" position. The reason is that there will be a vacuum inside the actuator if it is extended which over time can lead to water entering the actuator.
- If the actuator (without integrated controller) is mounted in an application where a mechanical stop prevents the endstop switches in the actuator from being activated, the actuator must be equipped with an electrical safety device (current monitoring) or external limit switch.

# Chapter 2

## Mounting guidelines

LINAK® linear actuators are quickly and easily mounted by slipping pins through the holes on each end of the units and into brackets on the machine frame and the load. The mounting pins must be parallel to each other as shown in Figure 1. Pins, which are not parallel to each other, may cause the actuator to bend and be damaged.

The load should act along the stroke axis of the actuator since off centre loads may cause bending and lead to premature failure. See Figure 2.

Make sure the mounting pins are supported in both ends. Failure to do so could shorten the life of the actuator. Also, avoid applying a skew load on the actuator.

The actuator can rotate around the pivot point in the front and rear end. If this is the case it is of high importance that the actuator is able to move freely over the full stroke length, both during the development and during daily operation. Please pay special attention to the area around the housing where parts can be trapped and cause damages to the application and actuator.

In applications with high dynamic forces LINAK recommends not to use the fully extended or retracted position over longer time, as this can damage the endstop system permanently.

Figure 1

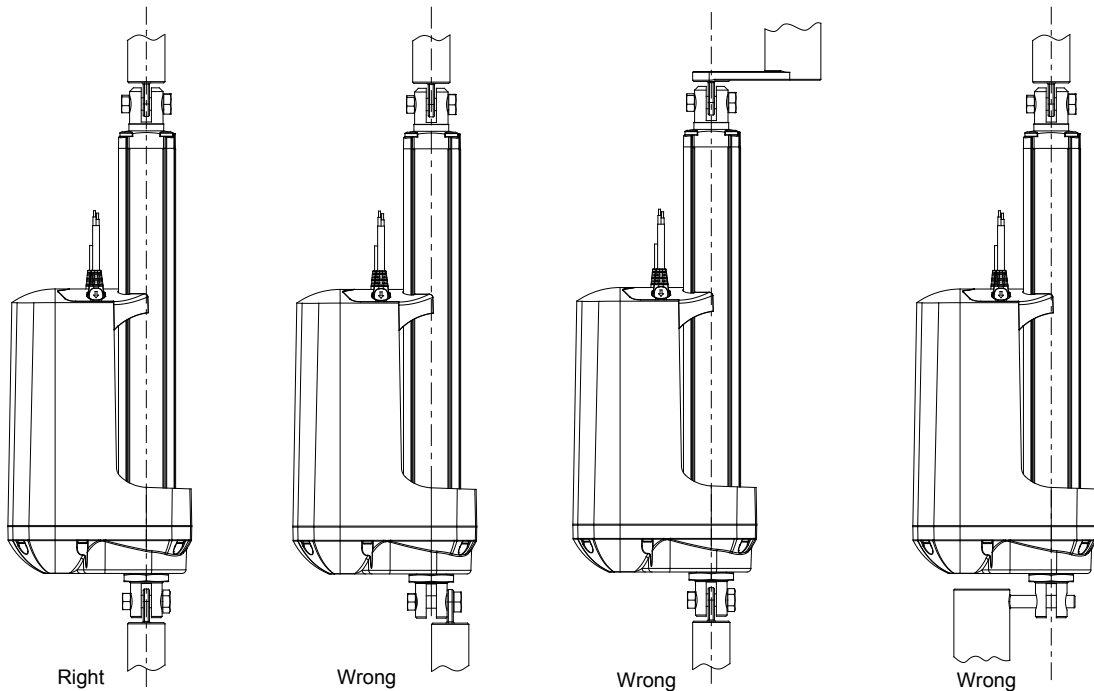
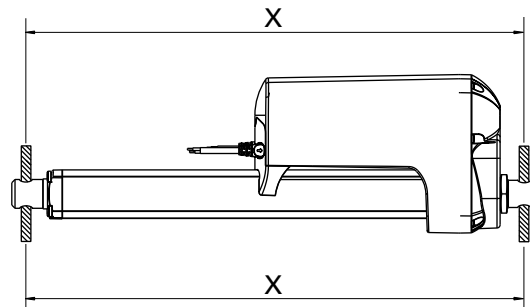

Figure 2



Please be aware that if the LA36 is used for solar applications the actuator must be mounted with the motor housing turned upwards and the wires pointing downwards.

## Mounting guidelines



- The mounting pins must have the correct dimension.
- The bolts and nuts must be made of a high quality steel grade (e.g. 10.8).  
No thread on the bolt inside the back fixture or the piston rod eye.
- Bolts and nuts must be protected so there is no risk for them to fall out.
- Do not use a torque that is too high when mounting the bolts for the back fixture or the piston rod eye.  
This will stress the fixtures.

### Please note:

**The piston rod eye is only allowed to turn 0-90 degrees.**



### Instruction concerning the turning of the piston rod eye and inner tube:

- When mounting and taking into use, it is not permitted to make excessive turns of the piston rod eye. In cases where the eye is not positioned correctly, it is permitted to first screw the eye down to its bottom position, at a maximum torque of 2Nm (1), and thereafter a maximum 90 degrees turn outwards again (2).
- As the piston rod eye can turn freely, it is important to ensure that the eye cannot rotate if the actuator is used in a pull application. If this happens, the actuator will be pulled apart and destroyed.

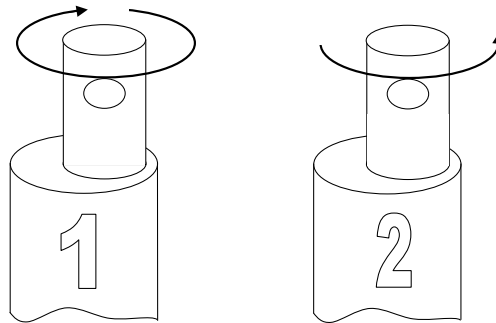

### Warning!

**If the actuator is used for pull in an application where personal injury can occur, the following is valid:**

It is the application manufacturer's responsibility to incorporate a suitable safety arrangement, which will prevent personal injury from occurring, if the actuator should fail.

### Warning!

**LINAK's actuators are not designed for use within the following fields:**

- Offshore installations
- Nuclear power generation
- Aeroplanes and other aircraft





## Mounting of cables

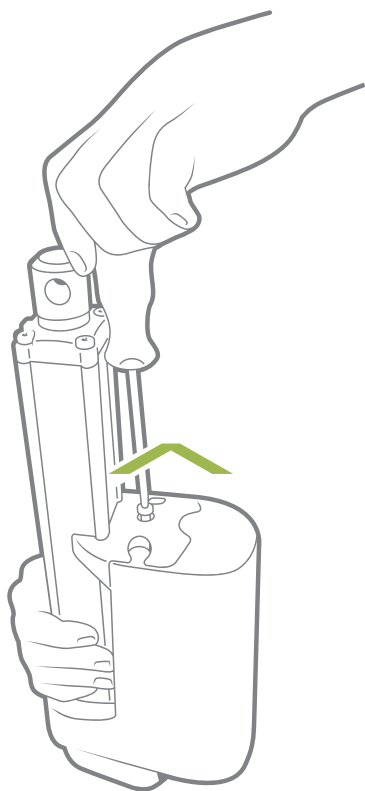

1. Unscrew the cover and remove the two blind plugs.

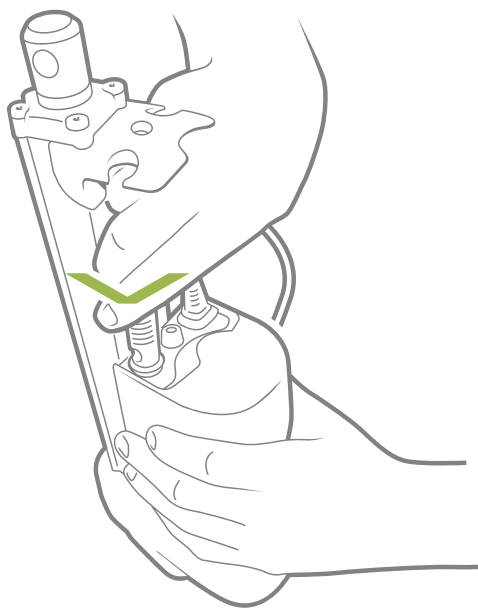

2. Plug in the power cable and/or the signal cable.

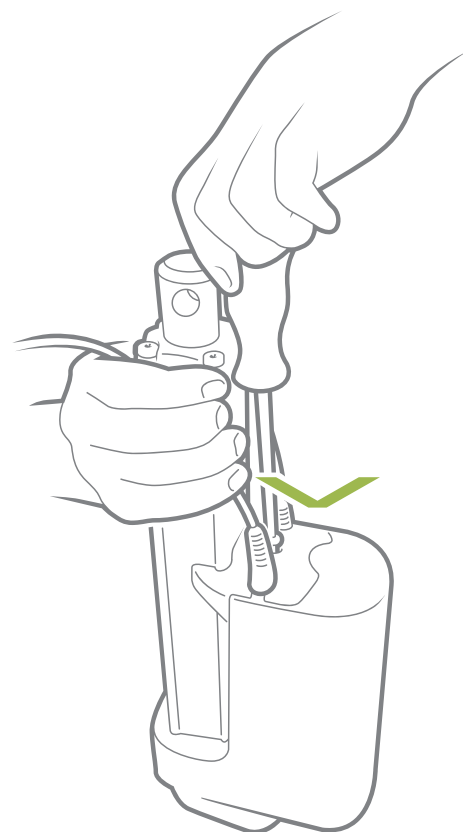

3. Slide the cover onto the actuator.

The torque of the cover screw is approx.  $3.5 \pm 0.3$  Nm

TORX 25IP



When changing the cables on a LINAK actuator, it is important that this is done carefully, in order to protect the plugs and pins. Before the new cable is mounted, we recommend that the socket is greased with vaseline, to keep the high IP protection and ensure an easy mounting. Please be sure that the plug is in the right location and fully pressed in before the cable lid is mounted.

Please note that if the cables are mounted and dismantled more than 3 times the plugs can be damaged. Therefore, we recommend that such cables are discarded and replaced.

Also note that the cables should not be used for carrying the actuator.

We recommend to take some precaution and design the wire connection in a way, where the cable end is kept inside a closed, protected area to guarantee the high IP protection.

## Electrical installation



- To ensure maximum self-locking ability, please be sure that the motor is shorted when stopped. Actuators with integrated controller provide this feature, as long as the actuator is powered.
- When using soft stop on a DC-motor, a short peak of higher voltage will be sent back towards the power supply. It is important when selecting the power supply that it does not turn off the output, when this backwards load dump occurs.



The power supply for actuators without integrated controller must be monitored externally and cut off in case of current overload.



### Recommended fuse for actuators without integrated controller

Type	Spindle Pitch (mm)	Thrust max. Push/Pull (N)	Typical Amp. at full load (A)				Recommended fuse			
			48 V	36 V	24 V	12 V	48 V	36 V	24 V	12 V
36080xxxxxxAxxxxH...	8	6800	-	-	-	17.0	-	-	-	40.0
36120xxxxxxAxxxxF...	12	2600	-	-	-	21.0	-	-	-	40.0
36120xxxxxxAxxxxG...	12	4500	-	-	-	20.7	-	-	-	40.0
36120xxxxxxAxxxxH...	12	6800	-	-	-	21.0	-	-	-	40.0
36200xxxxxxAxxxxF...	20	1700	-	-	-	22.0	-	-	-	40.0
36200xxxxxxAxxxxE...	20	500	-	-	-	20.0	-	-	-	40.0
36080xxxxxxBxxxxH...	8	6800	-	-	8.0	-	-	-	20.0	-
36120xxxxxxBxxxxF...	12	2600	-	-	10.4	-	-	-	20.0	-
36120xxxxxxBxxxxG...	12	4500	-	-	10.2	-	-	-	20.0	-
36120xxxxxxBxxxxH...	12	6800	-	-	10.3	-	-	-	20.0	-
36200xxxxxxBxxxxF...	20	1700	-	-	10.3	-	-	-	20.0	-
36200xxxxxxBxxxxE...	20	500	-	-	10.0	-	-	-	20.0	-
36080xxxxxxCxxxxH...	8	6800	-	8.0	-	-	-	16.0	-	-
36120xxxxxxCxxxxF...	12	2600	-	8.0	-	-	-	16.0	-	-
36120xxxxxxCxxxxG...	12	4500	-	8.0	-	-	-	16.0	-	-
36120xxxxxxCxxxxH...	12	6800	-	8.0	-	-	-	16.0	-	-
36200xxxxxxCxxxxF...	20	1700	-	8.0	-	-	-	16.0	-	-
36200xxxxxxCxxxxE...	20	500	-	8.0	-	-	-	16.0	-	-
36080xxxxxxDxxxxH...	8	6800	7	-	-	-	10.0	-	-	-
36120xxxxxxDxxxxF...	12	2600	7	-	-	-	10.0	-	-	-
36120xxxxxxDxxxxG...	12	4500	7	-	-	-	10.0	-	-	-
36120xxxxxxDxxxxH...	12	6800	7	-	-	-	10.0	-	-	-
36200xxxxxxDxxxxF...	20	1700	7	-	-	-	10.0	-	-	-
36200xxxxxxDxxxxE...	20	500	7	-	-	-	10.0	-	-	-

## Actuators with I/O Interface

Input/Output	Specification	Comments
Description	<p>I/O is a universal industrial interface which has been developed by LINAK. I/O is a common term used in the industry, to describe inputs and outputs.</p> <p>Flexibility is key when describing the possibilities of an I/O actuator. A total of six wires are customizable and this opens a world of intelligent actuator control.</p>	
Supporting PC tool for Windows	<p>Enhance your actuator experience with Actuator Connect™</p> <ul style="list-style-type: none"> <li>- Easy connection with Bluetooth® or a USB cable*</li> <li>- Flexibility in the development phase</li> <li>- Utilize data to learn about the actuator performance</li> </ul> <p>* Cable must be purchased separately (item no. 0367996)</p>	 <p>Download your free version at <a href="http://www.linak.com">www.linak.com</a></p>
<i>Power supply</i>		
Brown	<p>24 or 48 VDC + (VCC) Connect brown to positive 24 V ± 10 % - default current limit 13 A 48 V ± 10 % - default current limit 7.5 A</p>	<p>The actuator has an integrated h-bridge, and it is therefore important not to change the power supply polarity on the brown and blue wires. Power supply GND (-) is electrically connected to the housing</p> <p>If the temperature drops below 0 °C, all default current limits will automatically increase to 26 A for 24 V and 15 A for 48 V</p>
Blue	<p>24 or 48 VDC - (GND) Connect blue to negative</p>	
<i>Digital or analogue input</i>		
Red	<p><u>Features available:</u></p> <ul style="list-style-type: none"> <li>- Standard run - outwards</li> <li>- Impulse run - outwards or both directions (one wire)</li> <li>- Servo (+)</li> <li>- Proportional (+)</li> </ul>	<p><u>Standard run:</u> On/off voltages: &gt; 67 % of <math>V_{IN}</math> = ON and &lt; 33 % of <math>V_{IN}</math> = OFF Input current: 10 mA</p>
Black	<p><u>Features available:</u></p> <ul style="list-style-type: none"> <li>- Standard run - inwards</li> <li>- Impulse run - inwards</li> <li>- Servo (-)</li> <li>- Proportional (-)</li> </ul>	
<i>Digital output</i>		
Green	<p><u>Features available:</u></p> <ul style="list-style-type: none"> <li>- End stop reached (outwards)*</li> <li>- End stop zone reached (outwards)*</li> <li>- Actuator running*</li> <li>- Constantly high</li> <li>- Single hall XOR</li> <li>- Dual hall (A)</li> </ul>	<p><u>Digital outputs*:</u> The digital outputs are either active high or active low, depending on the preferred signal type.</p> <ul style="list-style-type: none"> <li>- Output voltage min. <math>V_{IN} - 2 V</math></li> <li>- Source current max. 100 mA</li> </ul>
Yellow	<p><u>Features available:</u></p> <ul style="list-style-type: none"> <li>- End stop reached (inwards)*</li> <li>- End stop zone reached (inwards)*</li> <li>- Actuator running*</li> <li>- Constantly high</li> <li>- Single hall XOR</li> <li>- Dual hall (B)</li> </ul>	

<i>Analogue output or digital input</i>		
Orange	<u>Features available:</u> - Analogue feedback (+) - Predefined position 1 - Run condition	
Light blue	<u>Features available:</u> - Analogue feedback (-) - Predefined position 2	
<i>Fixed wires</i>		
Violet	Parallel communication Violet wires must be connected together	The parallel drive function will support up to 8 actuators running simultaneously. It is possible to run parallel with a single power supply or run each actuator with separate power supplies. Please note: they must have the same potential and the power supply GND must be connected together (blue wires).
White	Service interface	The white wire is reserved for a service interface (USB to PC) and has no functionality during operation.
Grey	Bluetooth® antenna	The grey wire is used to strengthen the Bluetooth signal, allowing a stable wireless connection and has no functionality during operation.



- Current cut-offs should not be used as stop function! This might damage the actuator. Current cut-offs should only be used in emergencies!
- Current cut-off limits are not proportional with the load curves of the actuator. This means that the current cut-offs cannot be used as load indicator.
- There are tolerances on the spindle, nut, gear wheels etc. and these tolerances will have an influence on the current consumption for the specific actuator.

# Chapter 3

## Troubleshooting

Symptom	Possible cause	Action
<b>Motor runs but spindle does not move</b>	Gearing system or spindle damaged	Please contact LINAK
<b>No motor sound or movement of piston rod</b>	The actuator is not properly connected to the power supply	Check the connection to the power supply or the external control unit (if any)
	Customer fuse burned	Check the fuse
	Cable damaged	Change the cable
	For IC Advanced only: Wrongly connected	For IC Advanced only: <b>Please make sure that the power supply polarity is properly connected, otherwise you might damage the actuator</b> Check the wire connection on the internal control unit
<b>Excessive power consumption</b>	Misalignment or overload in the application	Align or reduce the load
		Try to run the actuator without load
<b>Actuator cannot lift full load or motor runs too slowly</b>	Misalignment or overload in the application	Align or reduce the load
		Try to run the actuator without load
	Insufficient power supply	Check the power supply
	For IC Advanced only: Internal current limit reached Actuator speed is too low	For IC Advanced only: Connect the actuator to BusLink and check the existing parameters



## Troubleshooting

Symptom	Possible cause	Action
<b>No signal or incorrect feedback output</b>	Cable damaged	Change the cable
	Wrongly connected	Check the wiring
	Signal is constantly high/low	Run the actuator to fully extended and retracted positions
	Feedback output overloaded	Reduce the load according to your chosen feedback type
	<u>For IC Advanced only:</u> Incorrect feedback output/level	<u>For IC Advanced only:</u> Connect the actuator to BusLink and check for correct feedback option
<b>Actuator runs in smaller steps</b>	Insufficient power supply	Check the power supply
	Load is higher than specified	Reduce the load
	<u>For IC Advanced only:</u> Internal safety procedure activated	<u>For IC Advanced only:</u> Connect the actuator to BusLink and check the following: - Reason for last stop (page 62) - Current cut-off levels in both directions
<b>Actuator cannot hold the chosen load</b>	Load is higher than specified	Reduce the load



For further assistance, please contact your local LINAK supplier.

## Troubleshooting for Parallel

Symptom	Possible cause	Action
<b>Actuators do not move</b>	The actuators are not properly connected to the power supply	<p>Check the connection to the power supply or the external control unit (if any)</p> <p><b>Please make sure that the power supply polarity is properly connected, otherwise you might damage the actuator</b></p> <p>Please see non-critical info below</p> 
	Wrong number of actuators in the system	Check if the number of actuators in the system match the number that was ordered
	Communication wires are not properly connected	Check the parallel communication wires for all actuators
	Signals run in/run out are not properly connected	Check the wire connection on the internal control unit
	Position lost	<p>Disconnect all cables, connect the actuator(s) to BusLink one at a time and check the following:</p> <ul style="list-style-type: none"> <li>- Reason for last stop (page 62)</li> </ul>
		After everything is connected, put power on all actuators at the same time. Then wait 10 seconds before the Run In/Run Out signals are activated
		If this does not work, initiate the Parallel manual service mode (page 56)
<b>Actuators cannot lift full load</b>	Insufficient power supply	Check the power supply while the actuator is running
	Overload in application	Reduce the load
		<p>Connect actuator(s) to BusLink one at a time and check the following:</p> <ul style="list-style-type: none"> <li>- Type of chosen Parallel system</li> <li>- Reason for last stop (page 60)</li> <li>- Current cut-off levels in both directions</li> </ul> <p>Please see non-critical info below</p> 
		After everything is connected, put power on all actuators at the same time. Then wait 10 seconds before the Run In/Run Out signals are activated



### Only for Non-critical Parallel:

Even if all actuators are not connected, the connected actuators will run after re-powering.  
More information on page 54

## Troubleshooting for Parallel

Symptom	Possible cause	Action
Actuators run in smaller steps before stop	Insufficient power supply	Check the power supply while the actuator is running
		Connect the actuator(s) to BusLink one at a time and check the following: - Reason for last stop (page 62) - Current cut-off levels in both directions
		After everything is connected, put power on all actuators at the same time. Then wait 10 seconds before the Run In/Run Out signals are activated
Signal cable damaged or removed under operation	All actuators stop at the same position	The signal and power cables MUST be re-connected to all actuators. <b>Ensure that no actuator is missing in the system. Otherwise, the system will not work, not even after re-powering</b> Please see non-critical info below  
		After everything is connected, put power on all actuators at the same time. Then wait 10 seconds before the Run In/Run Out signals are activated



# Chapter 4

## Specifications

Motor:	Permanent magnet motor 12, 24, 36 or 48 V *
Cable:	Motor: 2 x 14 AWG PVC cable Control: 6 x 20 AWG PVC cable **
Gear ratio:	6 different gear ratios available in steel (500 N, 1,700/2,600 N, 4,500 N, and 6,800 N)
Slip clutch:	Mechanical overload protection through an integrated slip clutch
Brake:	Integrated brake ensures a high self-locking ability. The brake is deactivated when the actuator is powered to obtain a high efficiency
Hand crank:	As a standard feature the actuator can be operated manually
Housing:	The housing is made of casted aluminium, coated for outdoor use and in harsh conditions
Spindle part:	Outer tube: Extruded aluminium anodised Inner tube: Stainless steel AISI304/SS2333 Acme spindle: Trapezoidal spindle with high efficiency
Temperature range:	- 30 °C to +65 °C      For IECEx/ATEX: - 25 °C to +65 °C - 22 °F to +149 °F      - 13 °F to +149 °F Full performance +5 °C to +40 °C
End play:	2 mm maximum
Weather protection:	Rated IP66 for outdoor use. Furthermore, the actuator can be washed down with a high-pressure cleaner (IP69K)

## Usage

- Duty cycle at 600 mm stroke is max. 20% (4 min. drive and 16 min. rest)  
Duty cycle at 601-999 mm stroke is max. 15% (3 min. drive and 17 min. rest)  
Duty cycle at 6800 N with 8 mm pitch is max. 5%
- Storage temperature: -55 °C to +105 °C
- Noise level: 73 dB (A) measuring method DS/EN ISO 3743-1 actuator not loaded

- **Safety device regarding functional failure:**

Safety nut

The LA36 has a built-in safety nut in push as an option. Actuators with safety nut in push can only function when used in push applications. The safety nut comes into operation should the main nut fail. Afterwards it is only possible to drive the actuator into the innermost position. Thereafter, the actuator will not function any more and must be sent for service

Mechanical endstop

LA36 is equipped with mechanical endstop

- \* Modbus actuators only 24 V - please see the Modbus installation guide:

<http://www.linak.com/techline/?id3=2363>

- \*\* Special control cables for the Modbus actuator - please see the Modbus installation guide:

<http://www.linak.com/techline/?id3=2363>

# Actuator dimensions

## TECHLINE® LA36:

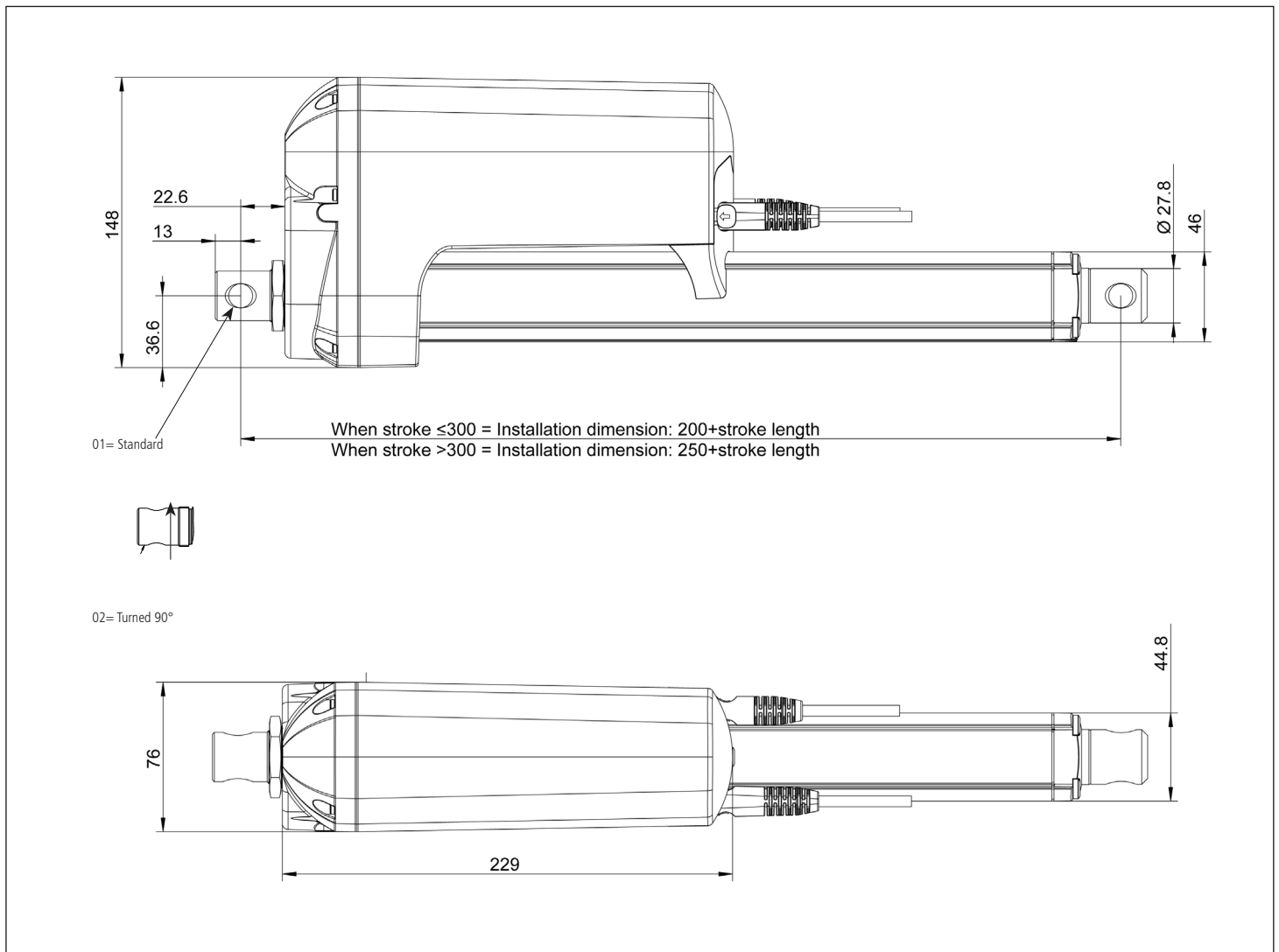

### Keep a clearance when mounting a bracket



When mounting a custom bracket on the moving part of the actuator, please observe the minimum clearance between bracket and cylinder top, when fully retracted, to avoid jamming and destruction of actuator drive train.

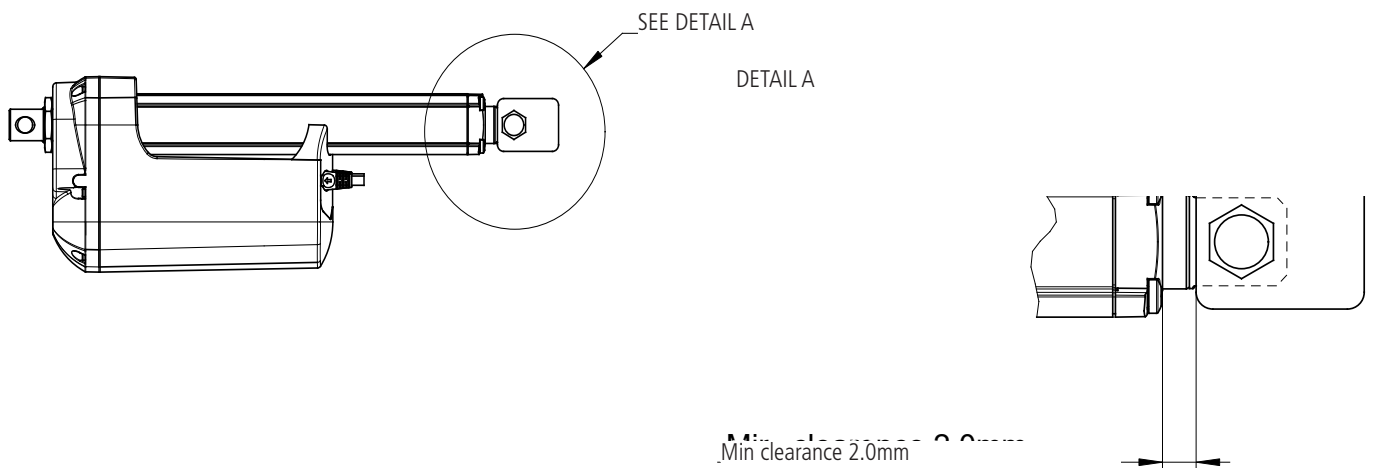

## Built-in dimensions

Piston rod	"0" /from the surface		"1" / to the centre of the hole		"2A" / to the centre of the hole	
Back fixture	Stroke <=300 Stroke > 300		Stroke <=300 Stroke > 300		Stroke <=300 Stroke > 300	
"0" / from the surface	189	239	194	244	194	244
"1" and "2" / to the centre of the hole	195	245	200	250	200	250
"4" / to the centre of the hole	195	245	200	250	200	250
"5" / from the surface	180	230	185	235	185	235
"6" / from the surface	180	230	185	235	185	235
"A" and "B" / to the centre of the hole	195	245	200	250	200	250
"C" and "D" / to the centre of the hole	195	245	200	250	200	250

Piston rod	"4" /from the surface		"5" / to the centre of the hole	
Back fixture	Stroke <=300 Stroke > 300		Stroke <=300 Stroke > 300	
"0" / from the surface	181	231	194	244
"1" and "2" / to the centre of the hole	187	237	200	250
"4" / to the centre of the hole	187	237	200	250
"5" / from the surface	172	222	185	235
"6" / from the surface	172*	222*	185	235
"A" and "B" / to the centre of the hole	187	237	200	250
"C" and "D" / to the centre of the hole	187	237	200	250

\* These built-in dimensions are measured according to the illustration below.

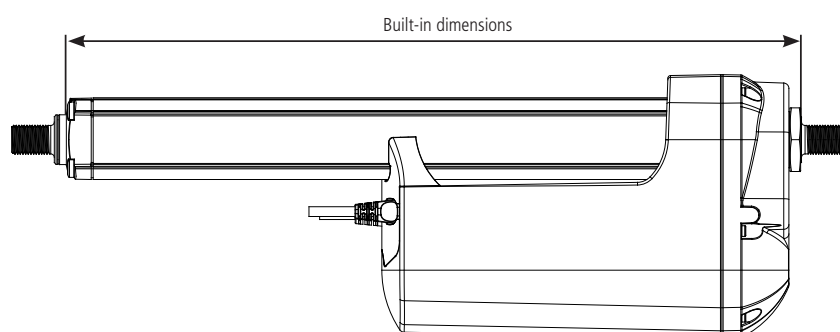

## Manual Hand Crank

The manual hand crank can be used in the case of power failure.



6 mm Allen key

The cover over the Allen key socket must be unscrewed before the Allen key can be inserted and the hand crank operated.

**Hand Crank Torque:** 6 - 8 Nm

**Hand Crank rpm:** Max. 65

**Piston rod movement per turn, app.:**

	8 mm	12 mm	16 mm	20 mm
Gear A	-	11 mm	14 mm	18 mm
Gear B	-	6 mm	8 mm	10 mm
Gear C	3 mm	4 mm	5 mm	7 mm
Gear F	-	-	-	27 mm



- The power supply has to be disconnected during manual operation
- If the actuator is operated as a Hand crank, it must only be operated by hand, otherwise there is a potential risk of overloading and hereby damaging the actuator.

## Speed and current curves 24 V motor

The values below are typical values and made with a stable power supply and an ambient temperature of 20 °C.

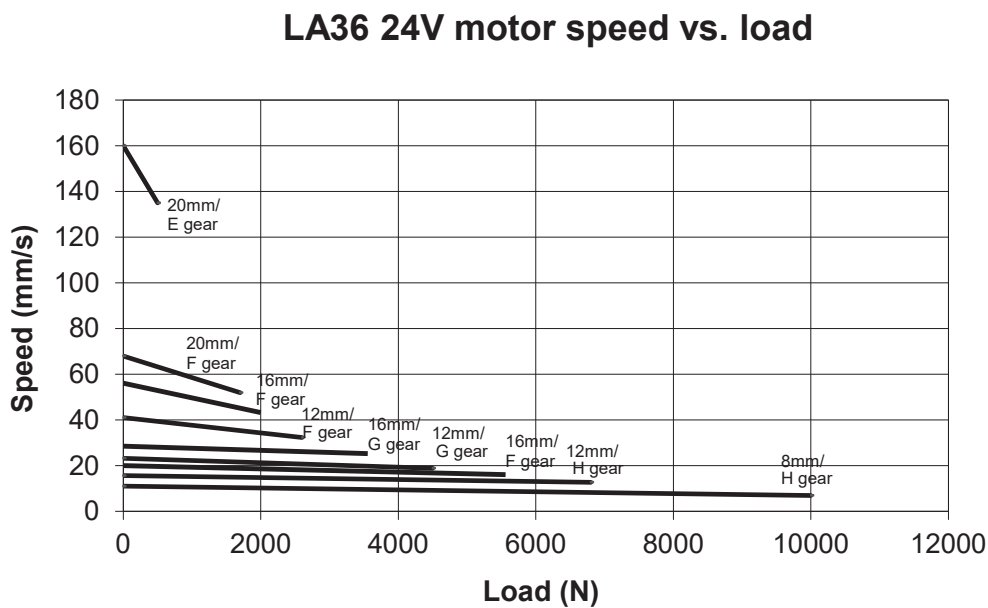
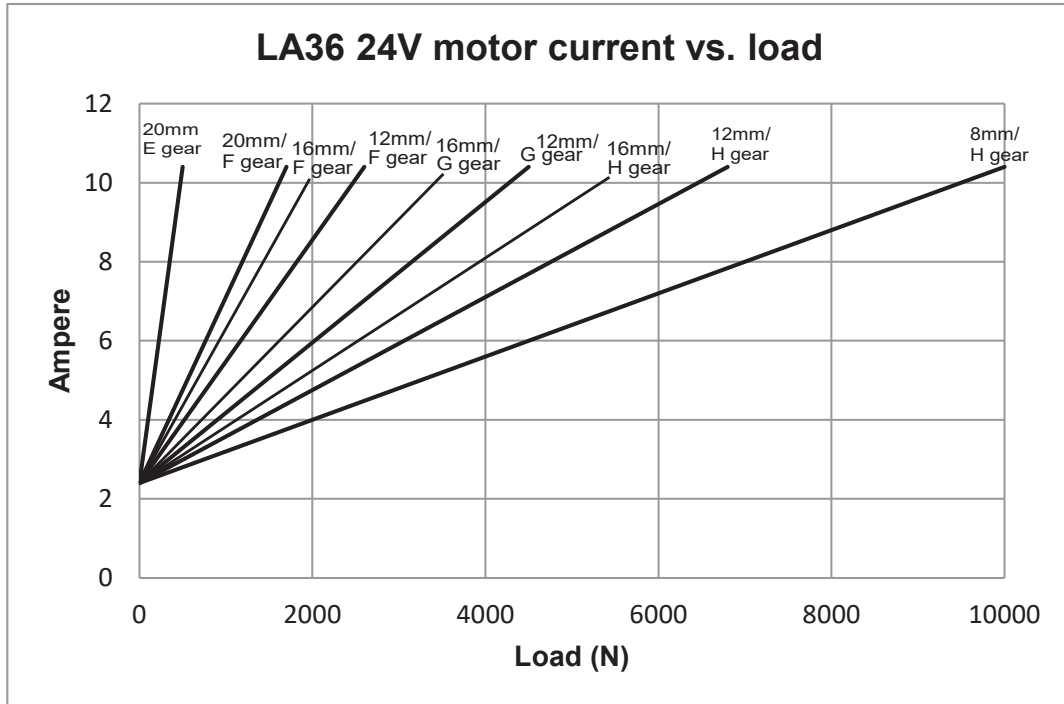

When ordering LA36F

When purchasing the LA36 actuator with fast gear and slide for the end-stop function, the customer has been informed that there is an increased risk that the activation arm for end-stop can be damaged during use, especially if the actuator runs to limit switch without load, both in the inner or outer position. A defective activation arm will inevitably lead to an inoperative end-stop function.



All measurements above describe the spindle pitch (e.g. 20 mm) and the gear type (e.g. E gear) of the actuator.

Speed and current are based on a nominal power supply of 12, 24, 36, 48 VDC.

## Speed and current curves 48 V motor

The values below are typical values and made with a stable power supply and an ambient temperature of 20 °C.

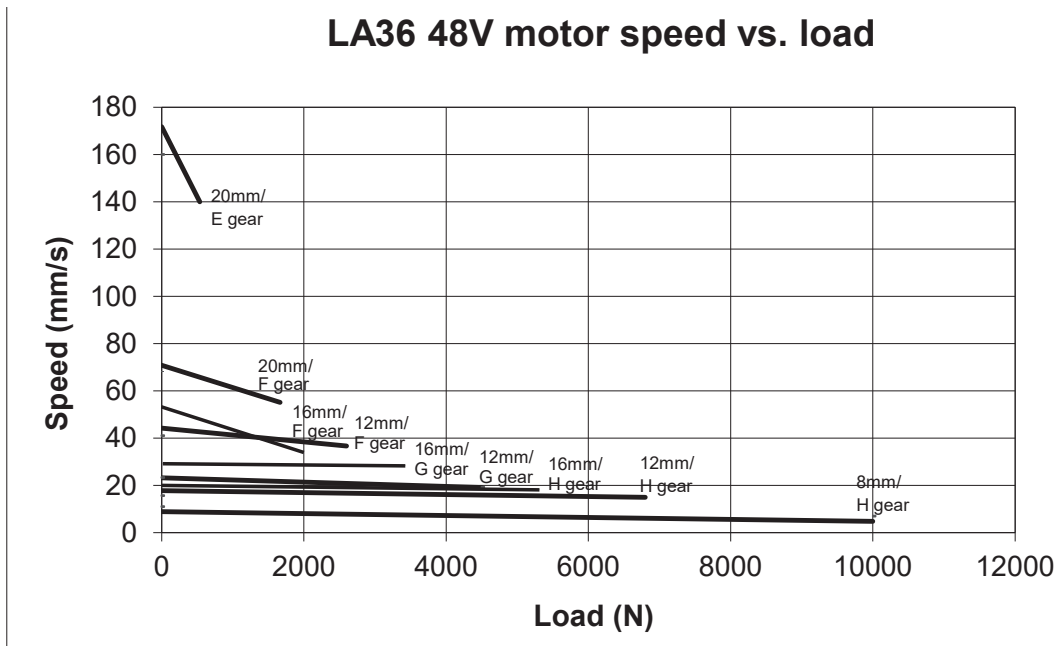
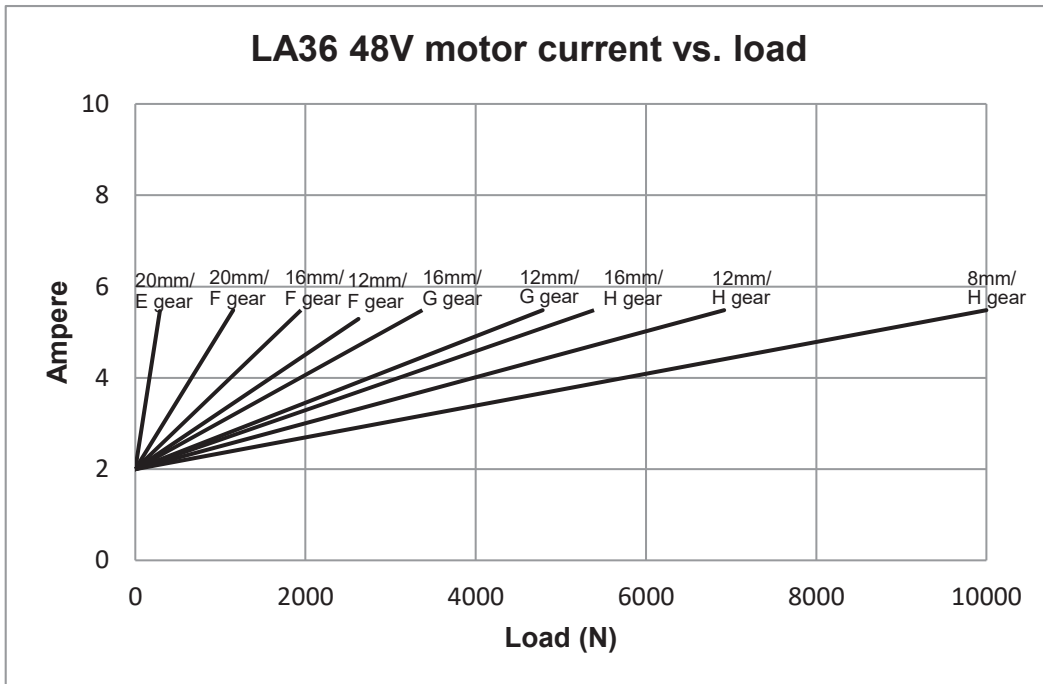

When ordering LA36F

When purchasing the LA36 actuator with fast gear and slide for the end-stop function, the customer has been informed that there is an increased risk that the activation arm for end-stop can be damaged during use, especially if the actuator runs to limit switch without load, both in the inner or outer position. A defective activation arm will inevitably lead to an inoperative end-stop function.



All measurements above describe the spindle pitch (e.g. 20 mm) and the gear type (e.g. E gear) of the actuator.

Speed and current are based on a nominal power supply of 12, 24, 36, 48 VDC.

**LINAK**® 

WE IMPROVE YOUR LIFE  
DESIGNED IN DENMARK  
Type : 36120250A001BA-646G304500X0000  
Item No. : J06292  
Prod. Date : 2015.11.09  
Max Load : Push 4500 N / Pull 4500 N IP66  
Power Rate: 24 V = / Max. 13 A  
Duty Cycle : 20%, Max. 4 min./16 min.  

 NOT TO BE OPENED BY UNAUTHORIZED PERSONNEL  
NE PAS OUVRIR PAR DU PERSONNEL NON AUTORISE

W/O #1234567-0001 MADE BY LINAK A/S DENMARK







 

Connection Diagram                      User Manual

- 1. Type: 36120250A001BA-646G304500X0000**  
Describes the basic functionality of the product
- 2. Item no.: J06292**  
Sales and ordering code
- 3. Prod. Date: YYYY.MM.DD**  
Production date describes when the product has been produced. This date is the reference for warranty claims
- 4. Max Load: Push 4500 N / Pull 4500 N IP66**  
Describes the maximum load that the product can be exposed to in compression and tension.  
This line also contains a reference to the product's IP protection degree
- 5. Power Rate: 24 VDC / Max. 13 Amp**  
Input voltage for the product and maximum current consumption
- 6. Duty Cycle: 20 %, Max. 4 min. / 16 min.**  
The duty cycle defines the maximum period during operation without interruption. After operation, a pause must be observed. It is important that the operator follows the instructions of the duty cycle; otherwise, a possible overload may result in reduced product life/errors
- 7. W/O #1234567-0001**  
The LINAK work order followed by a unique sequential identification number

## Key to symbols

The following symbols are used on the LA36 labels:

Symbol	Norms	Approvals
	WEEE Directive 2002/96/EC	Wheelie bin
	Compliance to all relevant EC directives	CE
	Regulatory Compliance Mark: The Australian safety/EMC regulations	RCM
	China Pollution control mark (also indicates recyclability)	China RoHS legislation
	ISO 7000- 0434A: Caution	
	Operating instructions	



## LA36 - Ordering example

### 36 120 000 A 9 23 B A - 6 1 6 G 3 0300 A C S 0 0 0

<b>Type:</b>	<b>36</b>	= LA36		
<b>Spindle type:</b>	080	= 8 mm		
	<b>120</b>	= 12 mm		
	160	= 16 mm		
	200	= 20 mm		
<b>Stroke length:</b>	<b>200</b>	= mm (example)		
	AXX	= 10xx mm		
	BXX	= 11xx mm	(In steps of 5 mm at strokes > 999 mm)	
	C00	= 1200 mm		
<b>Safety nut:</b>	0	= None		
	<b>A</b>	= Safety nut		
<b>Feedback:</b>	0	= None		
	A	= Analogue feedback output (single ended)		
	<b>9</b>	= Analogue feedback output (differential)		
	F	= PWM		
	H	= Dual Hall		
	K	= Single Hall (XOR)		
	L	= Potential free end stop signals		
	P	= Potentiometer (Only with the platform: Standard)		
	Z	= Hall and potentiometer		
X	= Special			
<b>Platform:</b>	00	= Standard (without limit switches)	01	= Standard (with limit switches)
LINAK interfaces:	13	= IC Basic	<b>23</b>	= IC Advanced
	33	= IC Parallel		
	A3	= I/O Basic	C3	= I/O Customized
	F3	= I/O Full		
Industrial/mobile interfaces:	04	= Modbus	06	= LIN bus (switch)
	16	= LIN bus (zero point)	07	= CAN SAE J1939 (switch)
	17	= CAN SAE J1939 (zero point)	08	= CANopen (switch)
	18	= CANopen (zero point)	XX	= Special
<b>Motor:</b>	A	= 12 VDC Normal	1	= 12 VDC With dummy clutch
	<b>B</b>	= 24 VDC Normal	2	= 24 VDC With dummy clutch
	C	= 36 VDC Normal	3	= 36 VDC With dummy clutch
	J	= 48 VDC Normal	4	= 48 VDC With dummy clutch
	X	= Special		
<b>Housing:</b> IP66 dynamic IP69K static	<b>A</b>	= Standard housing	6	= Reinforced housing
	6	= IECEx / ATEX approved housing	9	= Harsh environment housing*
<b>Reed:</b>	-	= Without magnet		
	+	= With magnet (for an externally mounted reed limit switch)		
<b>Colour:</b>	<b>6</b>	= Dark olivish grey NCS S7000-N*		
	X	= Special		
<b>Back fixture:</b>	<b>1</b>	= 0 degrees	3	= Ball eye
	2	= 90 degrees	4	= Outer thread
	5	= Inner thread	6	= Rotated (30° Interval)
	A	= 30 degrees	B	= 60 degrees
	C	= 120 degrees	D	= 150 degrees
	X	= Special		
<b>Piston rod eye:</b>	1	= With slot	2	= Solid
	4	= Outer thread	5	= Inner thread
	<b>6</b>	= Ball eye	X	= Special

\* The harsh environment housing is black

<b>Gearing:</b>	E	= Gear ratio 1:7 (F-gear)	F	= Gear ratio 1:18 (A-gear)	
	G	= Gear ratio 1:31 (B-gear)	H	= Gear ratio 1:46 (C-gear)	
<b>Brake:</b>	1	= Push	2	= Pull	
	3	= Push / Pull			
<b>Installation dimension:</b>	0300	= mm (example)			
	XXXX	= mm			
<b>End stop signals*:</b>	A	= A_HIGH / A_HIGH (default)	N	= LOW / LOW (none)	
	B	= A_LOW / A_HIGH	C	= A_HIGH / A_LOW	
	D	= A_LOW / A_LOW	E	= LOW / A_HIGH	
	F	= HIGH / A_HIGH	G	= LOW / A_LOW	
	H	= HIGH / A_LOW	J	= A_HIGH / LOW	
	K	= A_LOW / LOW	L	= A_HIGH / HIGH	
	M	= A_LOW / HIGH	O	= HIGH / LOW	
	P	= LOW / HIGH	Q	= HIGH / HIGH	
	<b>Connector:</b>	0	= None	C	= Flying leads
		7	= AMP super seal (moulded)	9	= Deutsch DT (moulded)
		H	= AMP	J	= Deutsch DT
		K	= AMP super seal	U	= Power cable UL1203 US
X		= Special			
<b>Cable:</b>	0	= None	A	= 90° angled connectors	
	S	= Straight	Y	= Y-Cable	
	X	= Special			
<b>Parallel mode:</b>	0	= Non-critical parallel	2-8	= Critical parallel (# of actuators in the system)	
<b>Software configuration:</b>	0	= Standard	X	= Special Configuration	
<b>Not used:</b>	0				

\* A\_High is active high and A\_LOW is active low. HIGH is constantly high and LOW is constantly low.

# Chapter 5

## Maintenance

- The actuator must be cleaned at regular intervals to remove dust and dirt and inspected for mechanical damages or wear.
- Inspect attachment points, wires, piston rod, cabinet, and plug, as well as check that the actuator functions correctly.
- To ensure that the pregreased inner tube remains lubricated, the actuator must only be washed down when the piston rod is fully retracted.
- The actuator is a closed unit and therefore requires no internal maintenance.
- In order to maintain a proper performance of the spherical eyes and to increase the resistance against environmental wear, we strongly recommend that the spherical eyes (ball bearings) mounted on actuators from LINAK are greased with anticorrosive grease or similar.

## Repair

Only an authorised LINAK® service centre should repair LINAK actuator systems. Systems to be repaired under warranty must be sent to an authorised LINAK service centre.

In order to avoid the risk of malfunction, all actuator repairs must only be carried out by an authorised LINAK Service shop or repairer, as special tools and parts must be used.

If a system is opened by unauthorised personnel there is a risk that it may malfunction at a later date.

## Main groups of disposal

LINAK's products may be disposed of, possibly by dividing them into different waste groups for recycling or combustion.

We recommend that our product is disassembled as much as possible at the disposal and that you try to recycle it.

## Warranty

There is an 18 months' warranty on TECHLINE products against manufacturing faults calculated from the production date of the individual products (see label). LINAK's warranty is only valid in so far as the equipment has been used and maintained correctly and has not been tampered with. Furthermore, the actuator must not be exposed to violent treatment. In the event of this, the warranty will be ineffective/invalid. For further details, please see standard terms of sale and delivery for LINAK A/S.

### Note:

Only an authorised LINAK® service centre should repair LINAK actuator systems. Systems to be repaired under warranty must be sent to an authorised LINAK service centre.

In order to avoid the risk of malfunction, all actuator repairs must only be carried out by an authorised LINAK Service shop or repairer, as special tools and parts must be used.

If a system is opened by unauthorised personnel there is a risk that it may malfunction at a later date.

The actuator is not to be opened by unauthorised personnel. In case the actuator is opened, the warranty will be invalid.

Product	Metal scrap	Cable scrap	Electronic scrap	Plastic recycling or combustion
LA36	X	X	X	X



## DECLARATION OF CONFORMITY

LINAK A/S  
Smedevænget 8

DK - 6430 Nordborg

hereby declares that LINAK Actuators:

36xxxxx0xxxxxx, 36xxxxx1xxxxxx, 36xxxxx2xxxxxx, 36xxxxx5xxxxxx

(The 'X' s in the product description can either be a character or a number, thereby defining the variation of the product)

complies with the EMC Directive 2014/30/EU according to following standards:

EN 55016-2-1:2009, EN 55016-2-3:2010+A1+AC, EN 55022:2011+AC Class B, EN 55025:2008  
EN 61000-4-2:2009, ISO 10605:2008, EN 61000-4-3:2006+A1, ISO 11452-2:2004, EN 61000-4-5:2006,  
ISO 7637-2:2004

complies with the ATEX Directive 2014/34/EU according to following standards:

EN 60079-0:2012, EN 60079-31:2014

complies with the RoHS2 Directive 2011/65/EU according to the standard:

EN 50581:2012

Additional information:

The system does also comply with the standard:

EN 55025:2008 Vehicles, boats and internal combustion engines - Radio disturbance characteristics - Limits and methods of measurement for the protection of on-board receivers: Radiated disturbance

Nordborg, 2016-05-11



**LINAK A/S**

John Kling, B.Sc.E.E.

Certification and Regulatory Affairs

Authorized to compile the relevant technical documentation

Original Declaration



## DECLARATION OF CONFORMITY

LINAK A/S  
Smedevænget 8

DK - 6430 Nordborg

hereby declares that

Actuator 36xxxxxADxxxBxx (LA36 BUS)

complies with the EMC Directive: 2014/30/EU according to following standards:  
EN 61000-6-1:2007, EN 61000-6-2:2005, EN 61000-6-3:2007, EN 61000-6-4:2007

complies with RoHS2 Directive 2011/65/EU according to the standard:  
EN 50581:2012

### Additional information:

The system does also comply with the standard:

DS/EN ISO 14982:1998 Agricultural and forestry machines - Electromagnetic compatibility - Test methods and acceptance criteria

DS/EN 13309:2001 Construction machinery - Electromagnetic compatibility of machines with internal power supply

ISO 13766:2006 Earth-moving machinery - Electromagnetic compatibility

and EMC requirements of:

DS/EN 60204-1:2006 Safety of machinery - Electrical equipment of machines - Part 1: General requirements

DS/EN 60204-32:2008 Safety of machinery - Electrical equipment of machines - Part 32: Requirements for hoisting machines

Nordborg, 2014-06-23

**LINAK A/S**

John Kling, B.Sc.E.E.

Certification and Regulatory Affairs

Authorized to compile the relevant technical documentation

Original Declaration



## DECLARATION OF CONFORMITY

LINAK A/S  
Smedevænget 8  
DK - 6430 Nordborg

Hereby declares that

Actuator LA36IC (36xxxxx7xxxxxxx, 36xxxxx8xxxxxxx,  
36xxxxx9xxxxxxx, 36xxxxxBxxxxxxx)  
LA36IC (36xxxxxxxx03xxxxxxxxxxxxxxxxxxx)

complies with the EMC Directive 2014/30/EU according to following harmonized standards:

EN 61000-4-2:2009, EN 61000-4-3:2006+A1+A2, EN 61000-4-4:2012, EN 61000-4-5:2014, EN 61000-4-6:2014, EN 61000-4-8:2010, EN 55016-2-3:2010+A1, EN 55016-2-1:2014, EN 55025:2008

complies with RoHS2 Directive 2011/65/EU according to the standard:  
EN 50581:2012

Additional information:

The device does comply with the standards:  
EN 61000-6-1:2007, Electromagnetic compatibility (EMC) - Part 6-1: Generic standards - Immunity for residential, commercial and light-industrial environments  
EN 61000-6-3:2007, Electromagnetic compatibility (EMC) - Part 6-3: Generic standards - Emission standard for residential, commercial and light-industrial environments  
EN 61000-6-2:2005, Electromagnetic compatibility (EMC) - Part 6-2: Generic standards - Immunity for industrial environments  
EN 61000-6-4:2007, Electromagnetic compatibility (EMC) - Part 6-4: Generic standards - Emission standard for industrial environments

The device does also comply with the standards:  
ISO 10605:2008, Road vehicles -- Test methods for electrical disturbances from electrostatic discharge  
ISO 11452-4:2005, Road vehicles -- Component test methods for electrical disturbances from narrowband radiated electromagnetic energy -- Part 4: Harness excitation methods  
ISO 11452-2:2004, Road vehicles -- Component test methods for electrical disturbances from narrowband radiated electromagnetic energy -- Part 2: Absorber-lined shielded enclosure  
ISO 7637-2:2004, Road vehicles -- Electrical disturbances from conduction and coupling -- Part 2: Electrical transient conduction along supply lines only

Nordborg, 2014-11-06

**LINAK A/S**  
John Kling, B.Sc.E.E.  
Certification and Regulatory Affairs  
Authorized to compile the relevant technical documentation

Original declaration



## DECLARATION OF CONFORMITY

LINAK A/S  
Smedevænget 8  
DK - 6430 Nordborg

Hereby declares that

Actuator LA36CAN series  
36xxxxCDxxx1xx, 36xxxxCDxxx2xx, 36xxxxCDxxxAxx, 36xxxxCDxxxBxx  
(The 'X' s in the product description can either be a character or a number, thereby defining the variation of the product)

complies with the EMC Directive 2014/30/EU according to following standards:  
EN 61000-4-2:2009, EN 61000-4-3:2006+A1+A2, EN 61000-4-4:2012, EN 61000-4-5:2014, EN 61000-4-6:2014, EN 61000-4-8:2010, EN 55016-2-3:2010+A1, EN 55016-2-1:2014, EN 55025:2008

complies with RoHS2 Directive 2011/65/EU according to the standard:  
EN 50581:2012

Additional information:

The device does comply with the harmonized standards:  
EN 61000-6-1:2007, Electromagnetic compatibility (EMC) - Part 6-1: Generic standards - Immunity for residential, commercial and light-industrial environments  
EN 61000-6-3:2007, Electromagnetic compatibility (EMC) - Part 6-3: Generic standards - Emission standard for residential, commercial and light-industrial environments  
EN 61000-6-2:2005, Electromagnetic compatibility (EMC) - Part 6-2: Generic standards - Immunity for industrial environments  
EN 61000-6-4:2007, Electromagnetic compatibility (EMC) - Part 6-4: Generic standards - Emission standard for industrial environments

The device does also comply with the standards:  
ISO 10605:2008, Road vehicles -- Test methods for electrical disturbances from electrostatic discharge  
ISO 11452-4:2005, Road vehicles -- Component test methods for electrical disturbances from narrowband radiated electromagnetic energy -- Part 4: Harness excitation methods  
ISO 11452-2:2004, Road vehicles -- Component test methods for electrical disturbances from narrowband radiated electromagnetic energy -- Part 2: Absorber-lined shielded enclosure  
ISO 7637-2:2004, Road vehicles -- Electrical disturbances from conduction and coupling -- Part 2: Electrical transient conduction along supply lines only

Nordborg, 2016-09-08

**LINAK A/S**  
John Kling, B.Sc.E.E.  
Regulatory Affairs Manager  
Authorized to compile the relevant technical documentation

Original declaration

**DECLARATION OF INCORPORATION OF PARTLY COMPLETED MACHINERY**

**LINAK A/S**  
Smedevænget 8  
DK - 6430 Nordborg

Herewith declares that LINAK TECHLINE ® products  
as characterized by the following models and types:

Linear Actuators      LA12, LA14, LA22, LA23, LA25, LA30, LA35, LA36, LA37

comply with the following parts of the Machinery Directive 2006/42/EC, ANNEX I, *Essential health and safety requirements relating to the design and construction of machinery*:

1.5.1 Electricity supply

The relevant technical documentation is compiled in accordance with part B of Annex VII and that this documentation or part hereof will be transmitted by post or electronically to a reasoned request by the national authorities.

**This partly completed machinery must not be put into service until the final machinery into which it is to be incorporated has been declared in conformity with the provisions of the Machinery Directive 2006/42/EC where appropriate.**

Nordborg, 2014-10-20



**LINAK A/S**  
John Kling, B.Sc.E.E.  
Certification and Regulatory Affairs  
Authorized to compile the relevant technical documentation

Original Declaration



# Chapter 6

## IECEX/ATEX

The IECEX/ATEX certified LA36 (optional) is designed for installation in dust filled atmospheres such as grain handling facilities, cement plants, saw mills or other dusty surroundings. Please note that the IECEX/ATEX approval is only for dust, and NOT for gas.

The IECEX/ATEX versions are suitable for applications in Group IIIC, Category 2D. Zone 21 and 22.



### Warnings

If the following is **not** complied with, the IECEX/ATEX certification will **not** be valid:

- Actuator specifications must be complied with
- If the actuator has no built-in current cut-off, one must be mounted
- Only IECEX/ATEX approved cables are to be used \*
- The power supply/signal cables for the actuator must be terminated in a safe location or alternatively by use of an Ex terminal box certified for special conditions for safe use
- **When mounting or if changing cables in IECE/ATEX approved applications, all applied standards must be respected to maintain the approval.**
- Afterwards it is crucial that the tightness is verified before the actuator is powered up.

### Operation of the device is only valid if:

- The product is used under the conditions described in the installation - and operation instruction
- Ambient operating temperature -25°C to +65°C depending on duty cycle
- Atmospheric conditions: Pressure 80 kPa (0.8 bar) to 110 kPa (1.1 bar); and air with normal oxygen content, typically 21% v/v
- Since the signal and power cables are not UV resistant they need to be shielded against UV light, e.g. daylight or light from luminaries
- The connection between the actuator and the rest of the machine/device shall be conductive, and furthermore the application shall be grounded in order to remove any Electro Static Discharge. This counts for both of the actuator's fixation points (Back Fixture and Piston Rod Eye)
- Safety and operation instructions are accessible and followed
- Not to be opened in areas with dust, and never by unauthorized personnel
- The production of IECEX/ATEX actuators require quality management systems and auditing. Therefore, only LINAK A/S is allowed to produce, modify or repair actuators in order to sustain the approval. No changes are to be made on the actuator after delivery

This manual is part of the equipment. The manufacturer keeps the right to modify specifications without advanced notice. Keep this manual for later use.

* LA36 IECEX/ATEX cable item no.	Length (mm) outside the actuator
0367114 - 5000	Customised length - up to 5m
0367115 - 5000	Customised length - up to 5m

### General indication of risk:

Installation of the device shall be performed by trained staff only, familiar with the safety requirements and risks. Check all relevant safety regulations and technical indications for the specific installation place.

Prevent failures and protect persons against injuries and the device against damage.

The person responsible for the system must secure that:

- Safety and operation instructions are accessible and followed
- Local safety regulations and standards are obeyed
- Performance data and installation specifications are regarded
- Safety devices are installed and recommended maintenance is performed
- National regulations for disposal of electrical equipment are obeyed

### Maintenance and repair

- Repairs on the device must be carried out by LINAK authorized persons only
- Only perform mounting described in this manual

During maintenance regard all safety regulations and internal operation instructions.

## Mounting of ATEX cables

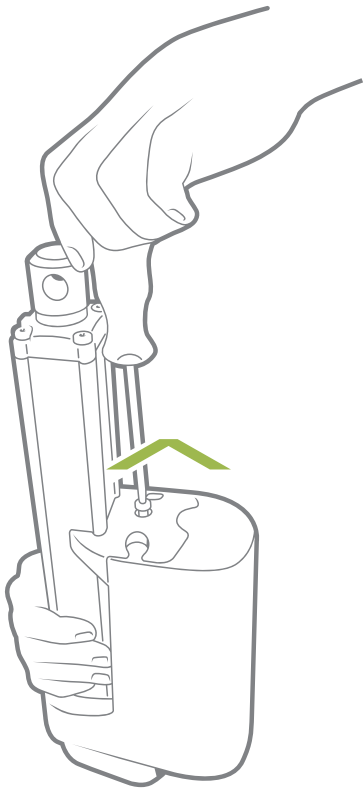

1. Unscrew the cover and remove the two blind plugs.

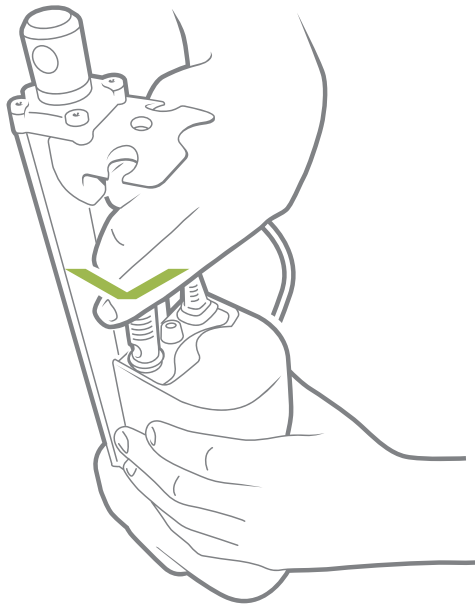

2. Plug in the power cable and/or the signal cable.

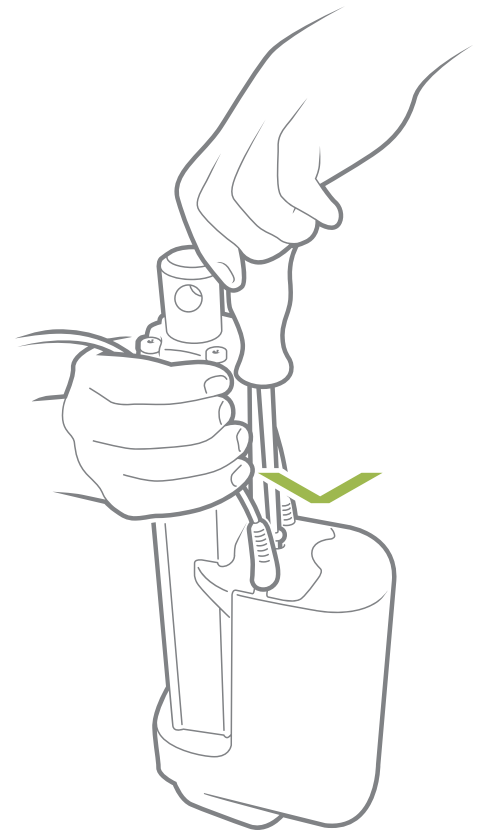

3. Slide the cover onto the actuator.

The torque of the cover screw is approx.  $3.5 \pm 0.3$  Nm

TORX 25IP



When changing the cables on a LINAK actuator, it is important that this is done carefully, in order to protect the plugs and pins. Before the new cable is mounted, we recommend that the socket is greased with vaseline, to keep the high IP protection and ensure an easy mounting. Please be sure that the plug is in the right location and fully pressed in before the cable lid is mounted.

Please note that if the cables are mounted and dismantled more than 3 times the plugs can be damaged. Therefore, we recommend that such cables are discarded and replaced.

Also note that the cables should not be used for carrying the actuator.

We recommend to take some precaution and design the wire connection in a way, where the cable end is kept inside a closed, protected area to guarantee the high IP protection.



# IECEX Certificate of Conformity

## INTERNATIONAL ELECTROTECHNICAL COMMISSION IEC Certification Scheme for Explosive Atmospheres

for rules and details of the IECEx Scheme visit [www.iecex.com](http://www.iecex.com)

Certificate No.: **IECEX TUN 14.0021X** issue No.: **0** Certificate history:

Status: **Current**

Date of Issue: **2015-10-13** Page 1 of 4

Applicant: **Linak A/S**  
Smedevænget 8, Guderup  
6430 Nordborg  
Denmark

Electrical Apparatus: **Actuator type LA 36**  
Optional accessory:

Type of Protection: **Protection by enclosure "tb"**

Marking: **EX tb IIIC T135 °C Db**

Approved for issue on behalf of the IECEx  
Certification Body:

Andreas Meyer

Position:

Head of the Certification Body

Signature:  
(for printed version)

Date:

**2015-10-13**

1. This certificate and schedule may only be reproduced in full.
2. This certificate is not transferable and remains the property of the issuing body.
3. The Status and authenticity of this certificate may be verified by visiting the [Official IECEx Website](http://www.iecex.com).

Certificate issued by:

**TÜV NORD CERT GmbH**  
Hanover Office  
Am TÜV 1  
30519 Hannover  
Germany

