

6

5

4

3

2

1

REVISION RECORD			
LTR	ECO NO:	APPROVED:	DATE:

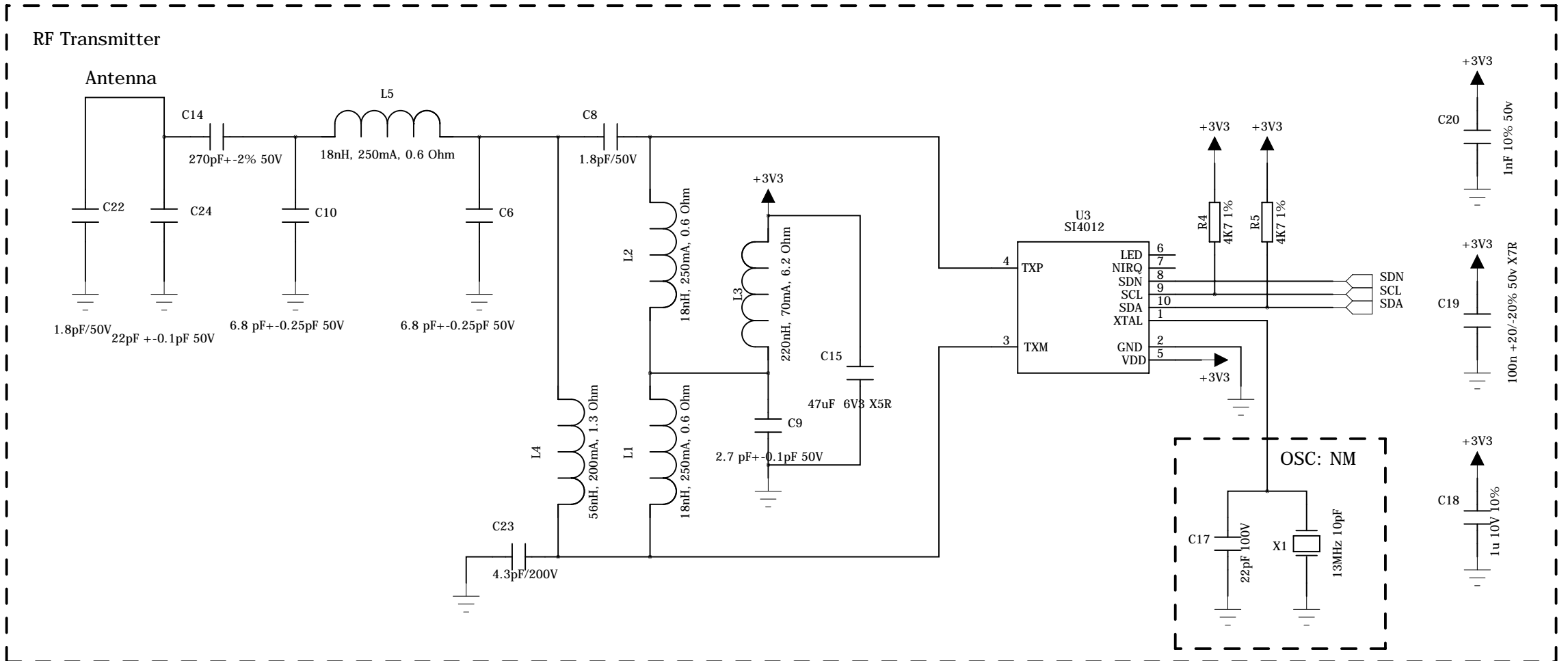
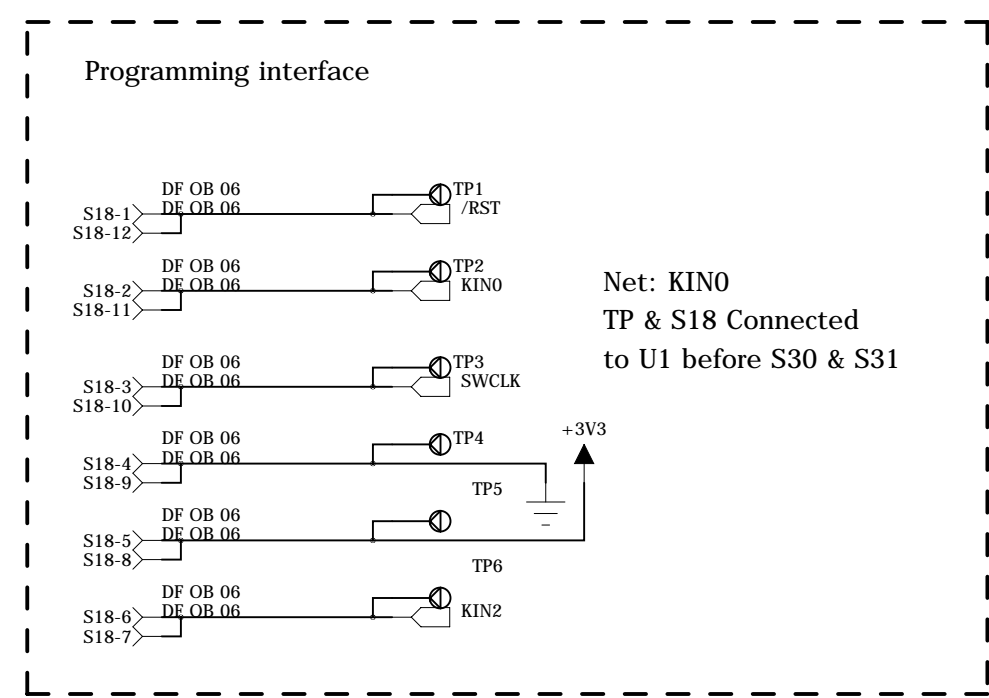
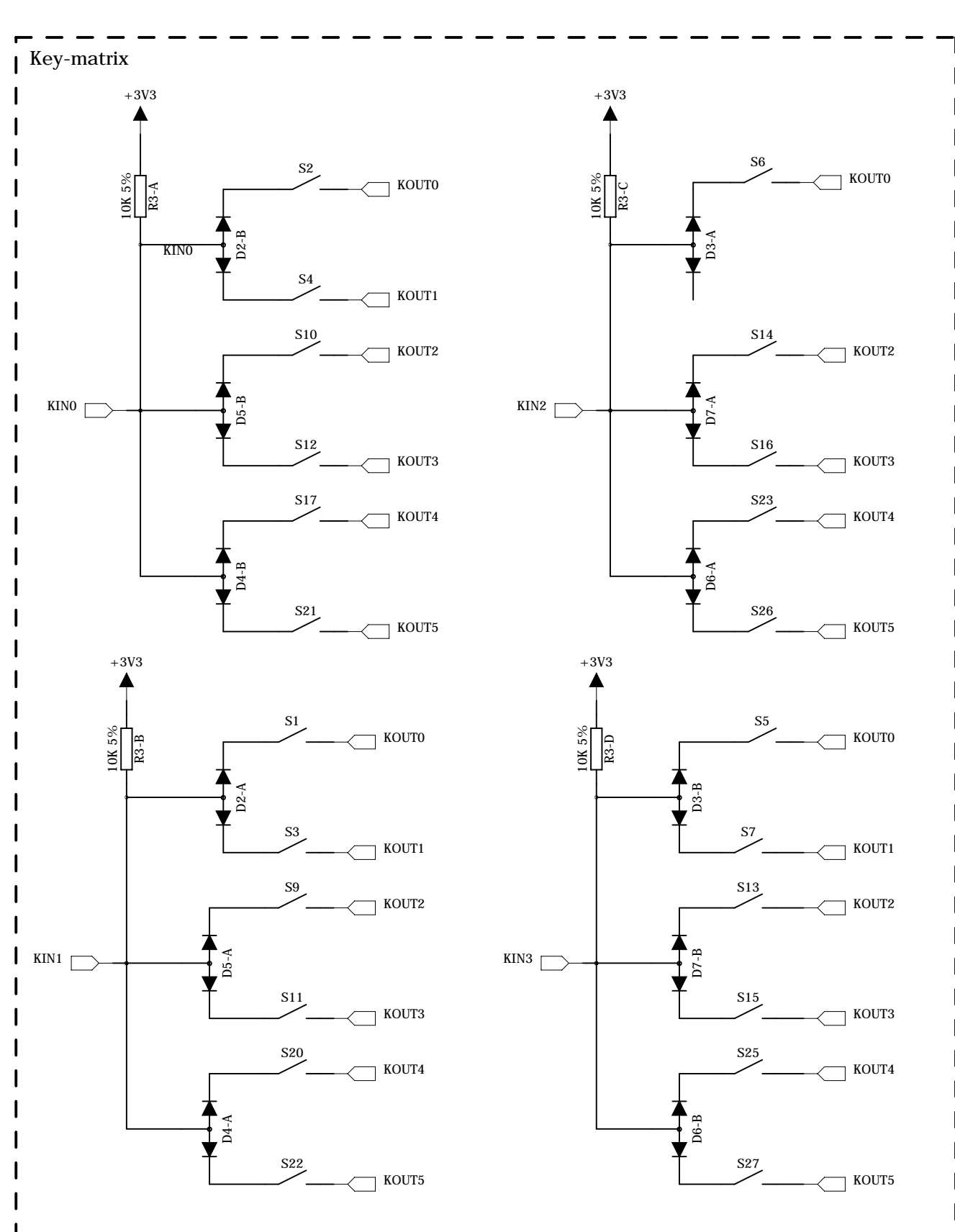
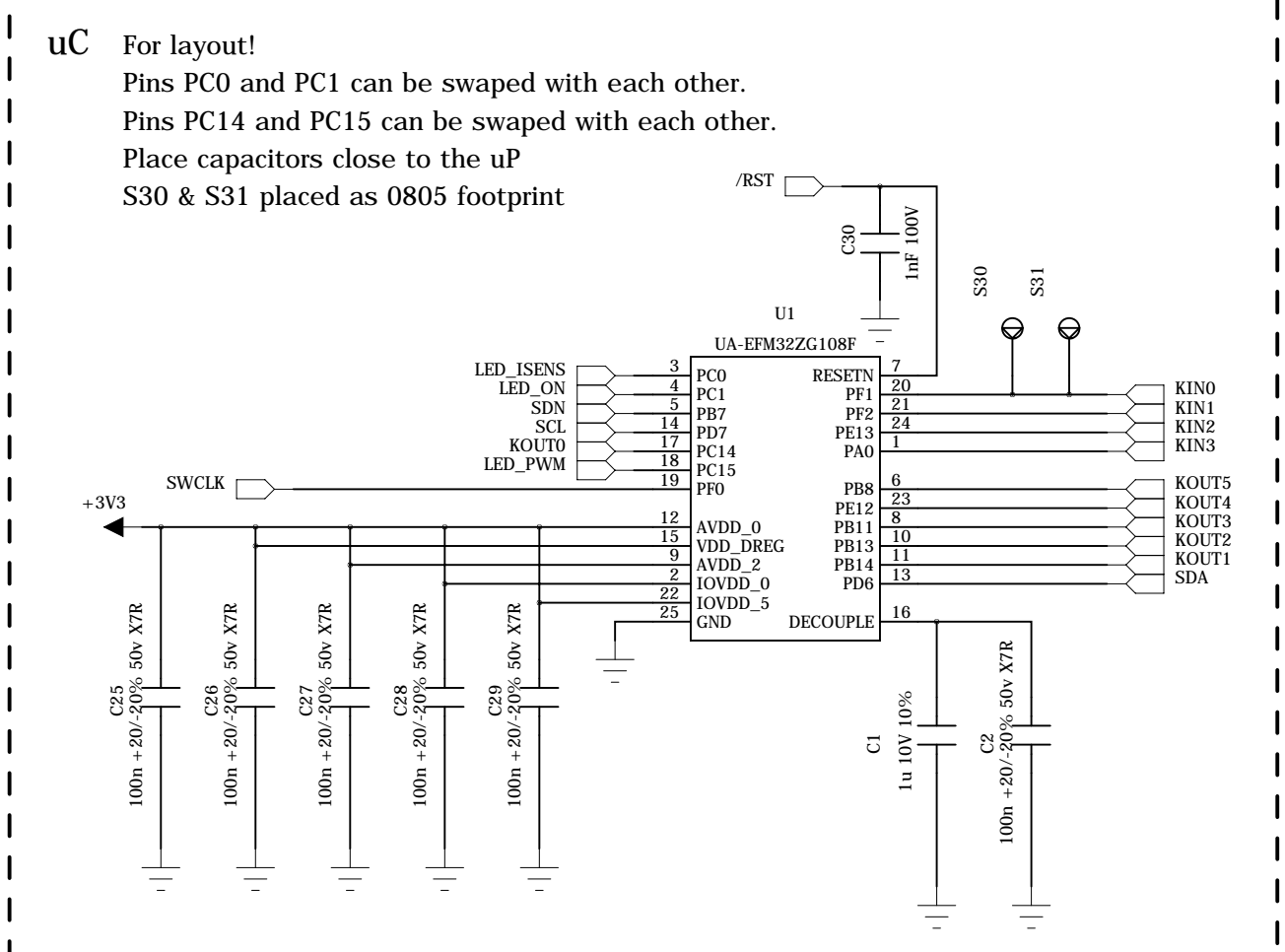
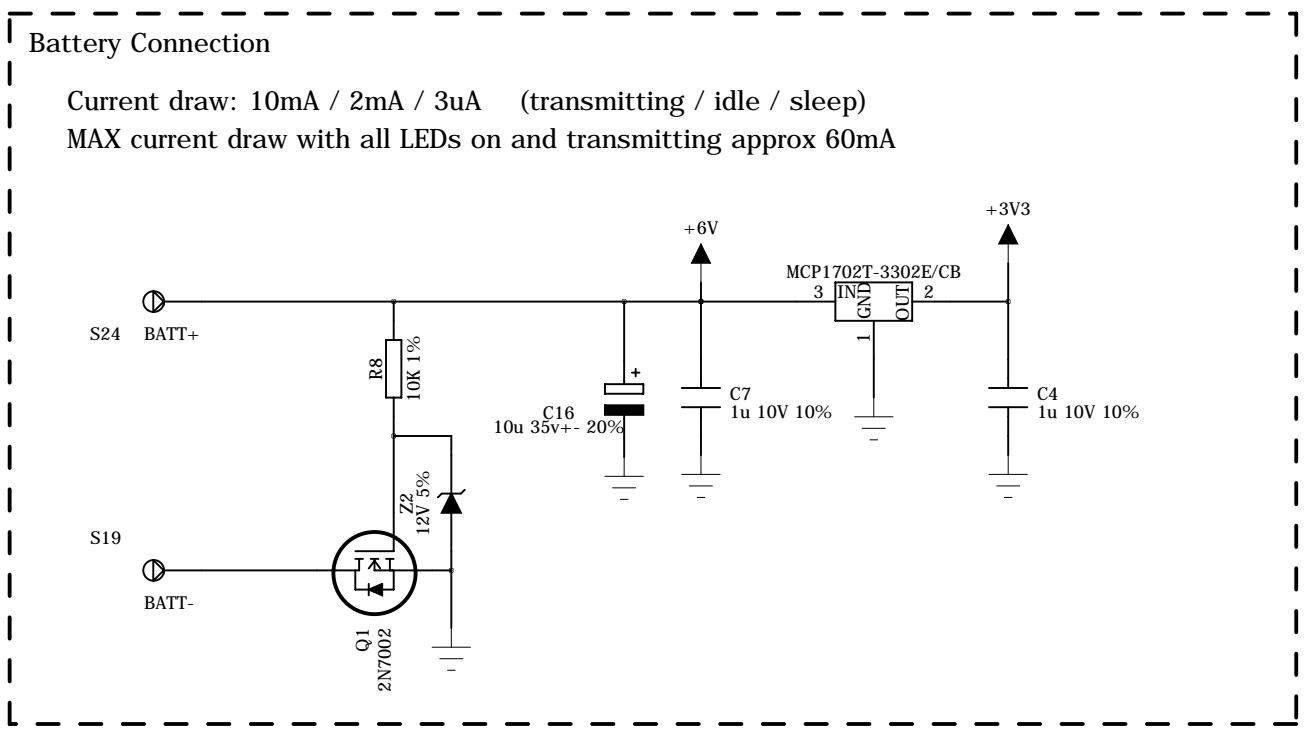

COMPANY:		LINAK A/S	
TITLE:		HC20RFS	
DRAWN:	HSA	DATED:	2014-02-24
CHECKED:		DATED:	
QUALITY CONTROL:		DATED:	
RELEASED:		DATED:	
CODE:	SIZE:	DRAWING NO:	
		10907483-C	
SCALE:		SHEET: OF	

6

5

4

3

2

1

REVISION RECORD			
LTR	ECO NO:	APPROVED:	DATE:

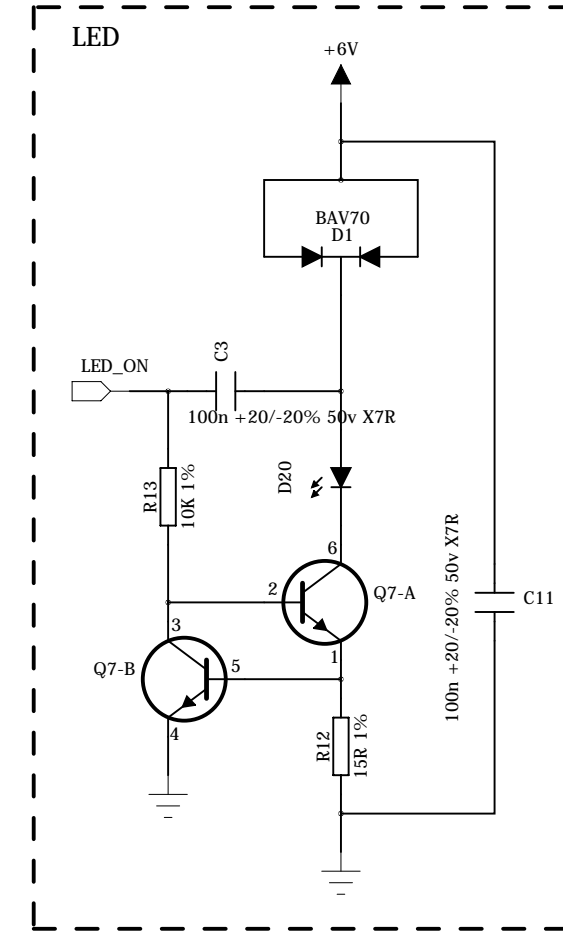
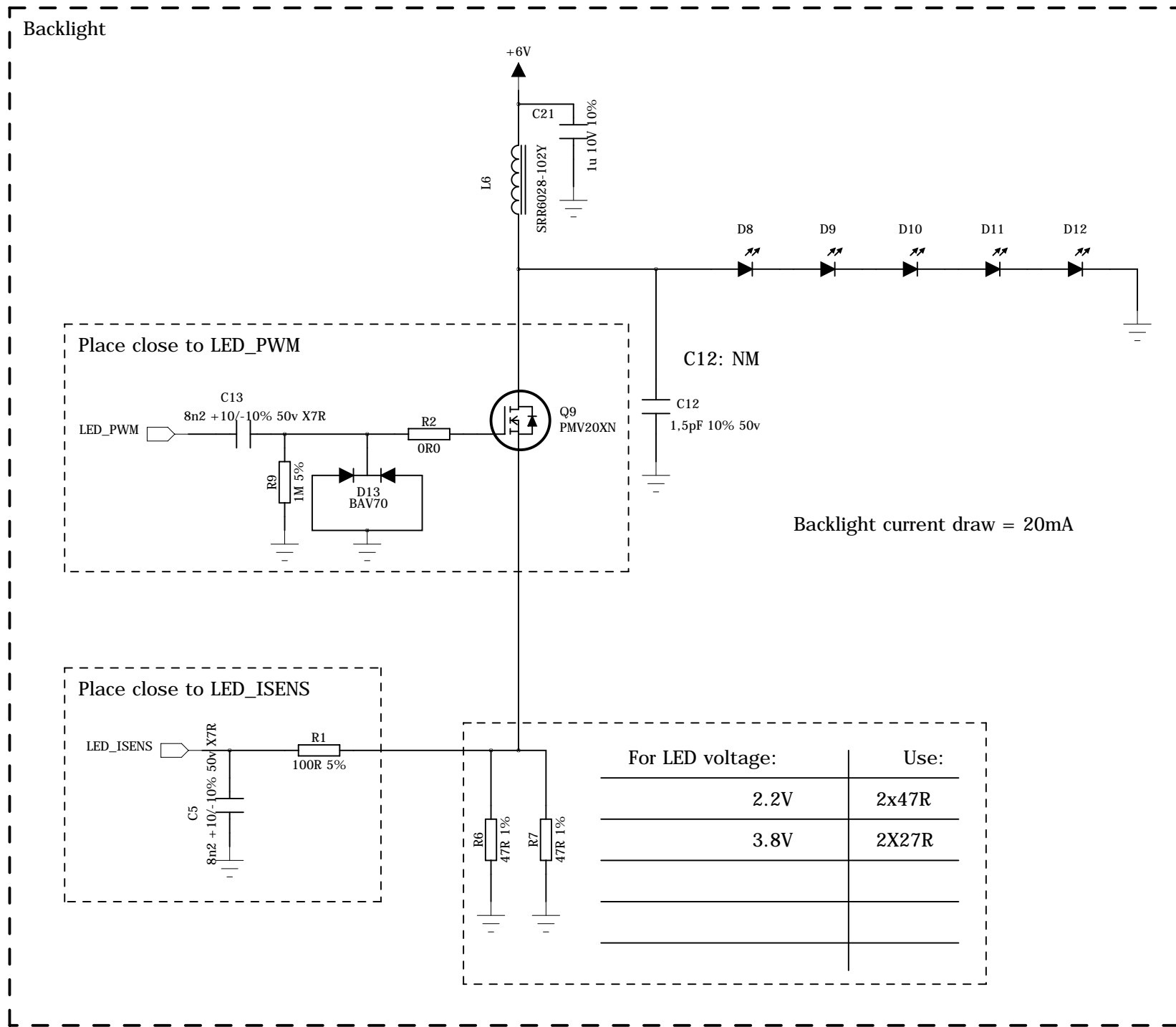

For LED voltage:	Use:
2.2V	2x47R
3.8V	2X27R

COMPANY:		LINAK A/S	
TITLE:		HC20RFS	
CODE:	SIZE:	DRAWING NO:	
		10907483-C	
SCALE:		SHEET: OF	

DRAWN:	DATED:
HSA	2014-02-24
CHECKED:	DATED:
QUALITY CONTROL:	DATED:
RELEASED:	DATED:

D

C

B

A

D

C

B

A