

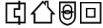

Designed in Denmark
DK - 6430 Nordborg

Item : CB6404+10019
Date : 2016.10.12
U In : 230 V~. 50/60Hz
I In : Max. 1A
IPX4
Int. : 10%, Max. 2 min. / 18 min.



NOT TO BE OPENED BY UNAUTHORIZED PERSONNEL
NE PAS OUVRIIR PAR DU PERSONNEL NON AUTORISÉ

W/O #1234567-0001 ASSEMBLED IN CHINA

The control box CB6 has been specially developed for use together with LA27/LA40 actuator in the care and rehab industry.

The control box is designed to be mounted on the actuator LA27/LA40 as with the CB9 and LA31 system.

The CB6 control box has a LED power ON indicator, detachable mains cable and strain relief for all cables.

The control box CB6 communicates with the LA27/LA40 actuator by means of the built-in end stop signal switches in the actuator. Due to the signal switches the power to the motor will be cut off in the control box and not in the actuator.

Usage:

- Duty cycle: 2/18; 2 minutes continuous use followed by 18 minutes not in use
- CB6 is approved according to EN60601-1 / UL60601-1
- The CB6 can only be combined with LA27/LA40 and HB30 / HB70 / HL70 / HB80 and HL80.



Recommendations

- Be aware of the handset configuration (e.g. CH1, 2, 3 should be CH1, 3, 4).
- Same cables variants as for CB9 CARELINE and CB12.

Connecting the system:

- Do not connect the mains cable until all actuators have been connected to the control box.
- Start by connecting the handset to the control box. The connection at the control box is marked with "HB".
- Connect the different actuators to the different channels on the control box. Each channel is marked with a number (e.g. "1", "2", "3"....).
- Check that all plugs are well connected and firm pushed into the connection plug.
Due to the fact that LINAK control boxes are designed for a high IP degree, a firm force can be required.
- CONNECT the mains and turn on the power!
- Finally, connect the battery (BA18) with special T-cable or normal battery cable depending on the specified system.
- The actuators can now be operated by pushing a button on the handset. Use only one button at a time.

If the control box is equipped with special software, an initialising process might be necessary. This process is described in the software specification.

CB6 system diagram

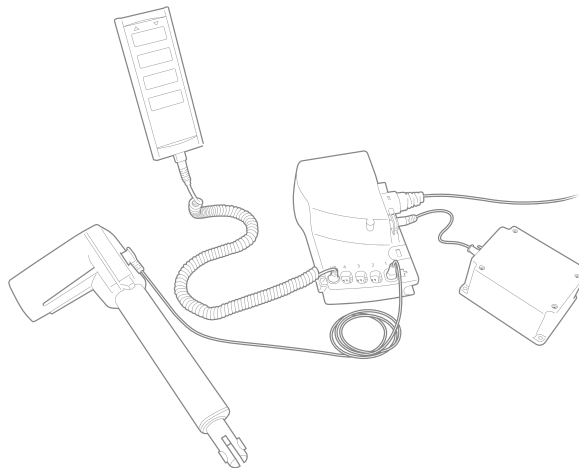

Attention should be paid to the following:

- Control boxes must only be connected to the mains voltage specified on the label.
- The control box must be connected in such a way that the cables are not trapped, exposed to tension or sharp objects, when the application is moved in different directions.



WE IMPROVE YOUR LIFE
DESIGNED IN DENMARK

Item : CB6S654+U2009 W/O #1234567-0001
Date : 2015.01.07
U In : 230 V~, 50/60 Hz
I In : Max. 2 A

Int. : 10%, max. 2 min. / 18 min.
S.V. P/N.: Testsoftware Ver. 1.2 IPX6 OBMe
"CONTACT LINAK FOR APPLICATION ADVICE BEFORE INSTALLING"
"CABLE LOCK MUST ALWAYS BE MOUNTED WHEN IN USE"
NOT TO BE OPENED BY UNAUTHORIZED PERSONNEL
NE PAS OUVRIR PAR DU PERSONNEL NON AUTORISÉ



ASSEMBLED IN CHINA



WE IMPROVE YOUR LIFE
DESIGNED IN DENMARK

Item : CB6S674+H3409 W/O #1234567-0001
Date : 2015.01.07
U In : 100-240 V~, 50/60 Hz
I In : Max. 5 A

Int. : 10%, max. 2 min. / 18 min.
IPX6 OBMe SMPS
"CONTACT LINAK FOR APPLICATION ADVICE BEFORE INSTALLING"
"CABLE LOCK MUST ALWAYS BE MOUNTED WHEN IN USE"
NOT TO BE OPENED BY UNAUTHORIZED PERSONNEL
NE PAS OUVRIR PAR DU PERSONNEL NON AUTORISÉ



ASSEMBLED IN CHINA

The CB6 OBMe is a powerful control box with switch mode power supply typically used for applications like hospital beds, couches/tables for treatment and examination and other medical applications. The universal input voltage makes the control box adaptable to the world-wide market irrespective of the input voltage.

Approvals:

CB6 OBMe is approved according to UL60601-1 and EN60601-1.

Possible combinations.

CB6 OBMe is meant for use with:

LA27 std. motor (cable type 'B'),
LA27 std. motor (cable type "A" = encoded) with / without Hall
LA31 std. / fast motor with / without Hall,
LA34 std. / small / fast motor with / without Hall (fast motor not max. load),
LA44 std. / fast motor with / without Hall (fast motor not max. load),
BL1 (only with +35% transformer type) with / without Hall,
HB7x, HL7x, HB8x, FSE/FSL, FS2, MJB, DJB, ACC, ACC, ACC.

CB6 OBMe – with transformer has been approved for CLASS I operation incl. CLASS I cables (without pigtail for earth).

CB6 OBMe – with SMPS is not approved for CLASS I operation, basically because of the design of the housing. However the PCB contains 2 x fuses (phase, neutral) as required for CLASS I operation.

If a mains cable with pig tail is applied CLASS I is obtained – however the CB label will indicate CLASS II! At the end of the day the OEM user applying for an application approval must clarify if such a solution is accepted by the used testhouse.



Battery Operation:

- If the battery voltage is at 'low level' a battery alarm beeps constantly by activating the HB/ACX. Low level means that battery charging is necessary to maintain the best possible lifetime. Low level battery limit corresponds to approx. 19 V (+/- 5%).
- If the battery voltage is at 'critical level' the battery alarm function shuts down all operation immediately. If trying to operate the system anyway, the battery could become deeply drained or the actuator system could be damaged. When at critical battery level there is a risk that the processor will incorrectly monitor end of stroke. Crashing the actuator could be a result. Critical level limit corresponds to approx. 17.5 V (+/- 5%).
- If battery back-up is applied it only commences battery charging when it is connected to the mains.
- A battery stored at 25° C has to be recharged every 6 - 7 months.
- Prior to first use of LINAK batteries, please make sure that they are charged for 24 hours in order to reach proper function and prolong the lifetime of the batteries.
- The longest lifetime is obtained when the battery is fully charged.

If Backlight supported HB is used:

- When CB6 OBMe is powered by mains voltage:
 - If an HB button is activated the backlight illuminates fully. When the HB button is released the light is dimmed again after approx. 10 - 15 sec. Backlight turns completely off after 2 min.
 - Exception: While charging the HB backlight will stay on dimmed until charging is finished.
- When CB6 OBMe is powered by battery:
 - If a HB button is activated the backlight illuminates fully. When the HB button is released the light is dimmed again after approx. 10 - 15 sec. Backlight turns completely off after 2 min.

1st Failure safe monitoring

Is made in two ways on the OBMe platform. It may be difficult to observe the LED status (hardware) if CB6 OBMe is placed under a bed, therefore it is now monitored by software as well.

- CB6 OBMe is equipped with a 1st Failure safe indication controlled by HW (power request). At normal operation (no failure observed) the power LED turns yellow when a HB button is activated.

If the LED has turned yellow AND the HB has NOT been activated, it indicates that a failure has occurred (1st Failure).

NOTE: Even though the LED illuminates yellow before the HB is activated it is possible to operate the CB6, however the 1st. Failure is somehow still in the CB and must be removed to prevent a further failure causing a hazardous failure to happen.

- To meet the safety requirements the device must have a dual switch safety concept. Further information about OpenBus™ safety concepts please contact your local LINAK.
- The safety function must be monitored and this monitoring is implemented in the SW. In case of a failure (fatal error) any further operation of any channels are prevented. At a fatal error the CB6 OBMe responds with the following information:
- Failure indication:
 - ▲ all ACO LED's are blinking
 - ▲ The CB6 OBMe buzzer beeps shortly if a handset is activated
 - ▲ The error can be reset by activating H0 and H1 OR H10 and H11 on a handset.

Compatibility – CB6 OBMe:

- CB6 OBMe supports both digital and analog encoded signals.

4. CB6P2 (MEDLINE® CARELINE®)



The CB6P2 platform is introduced to obtain a powerful and optimised solution to customers looking for existing analogue input systems. It is based on OpenBus™ technology, but to meet existing analogue systems it has an analogue input similar to HB40 and therefore OpenBus™ accessories cannot be connected.

Combination Overview

CB6P2 is meant for use with:

- LA27 std. motor with Hall (cable type 'A')
- LA27 std. motor (cable type 'B'),
- LA31 std. / fast motor with / without Hall,
- LA34 std. / small / fast motor with / without Hall (fast motor not max. load),
- LA40 std. motor with / without Hall
- LA44 std. / fast motor with / without Hall (fast motor not max. load),
- BL1 (only with 270W transformer type) with / without Hall, HB7x, HL7x, HB8x, ACL/ACM/ACP (HB40-like)



Recommendations

Battery Operation:

- If the battery voltage is at 'low level', a battery alarm beeps constantly when the HB/ACx is activated. (Low level means that battery charging is necessary to maintain the best possible life time. Low level battery limit corresponds to approx. 19 V (+/- 5%).
- If the battery voltage is at 'critical level' the battery alarm function shuts down all operation immediately. Critical level limit corresponds to approx. 17.5 V (+/- 5%).
- If battery back-up is applied it only commences battery charging when it is connected to the mains.
- A battery stored at 25° C has to be recharged every 6-7 months.
- Prior to first use of LINAK batteries, please make sure that they are charged for 24 hours in order to reach proper function and prolong the lifetime of the batteries.
- The longest lifetime is obtained when the battery is fully charged.



Designed in Denmark
DK - 6430 Nordborg

Item : CB65634+Z2009
Date : 2016.10.12 W/O #1234567-0001
U In : 230 V~, 50/60 Hz
I In : Max. 2 A

Int. : 10%, max. 2 min. / 18 min.
S.W. P/N.: 78212 Ver. 1.00 IPX6 OBF
"CONTACT LINAK FOR APPLICATION ADVICE BEFORE INSTALLING"
"CABLE LOCK MUST ALWAYS BE MOUNTED WHEN IN USE"

NOT TO BE OPENED BY UNAUTHORIZED PERSONNEL
NE PAS OUVRIR PAR DU PERSONNEL NON AUTORISE

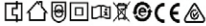

ASSEMBLED IN CHINA

CB65 is part of the LINAK OpenBus™ product range - that provides more flexible solutions no matter which actuator concept is preferred.

Mounting of CB65 – article no. 9271233

Apart from LA27 and LA40, it is not possible to mount CB65 onto LINAK actuators. In such case you need a CB6 mounting bracket which can be welded or likewise to the application.

This bracket is shown below:

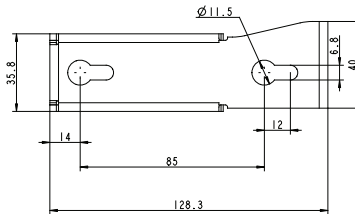
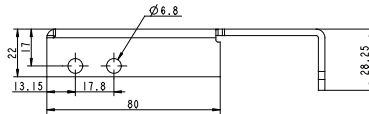
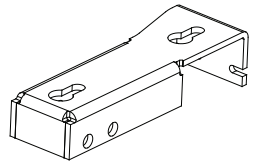
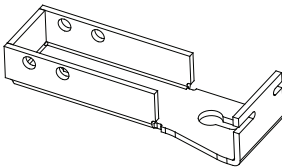

Precautions:

Thermal protection:

OBF only

The CB is equipped with a thermal protection to avoid thermal overload of the FET transistors used to control the actuators.

When triggering the thermal protection all movement of the actuators will stop and the buzzer will sound for 5 seconds constantly. The 5 second alarm will be reinitiated each time the handset/ACP or similar is activated until the CB is cooled down enough to allow a movement again

The thermal monitoring system monitors a temperature rise and not an absolute temperature. The monitoring system has been designed to operate up to an ambient temperature of 40 degrees. If the CB is exposed to a temperature higher than 40 degrees for several hours while powered it will adapt to this temperature. In this case there is a risk of damaging the FET transistors without triggering the thermal protection.

At first power up, after programming a new SW into the CB, the 'temperature reference value', used by the thermal monitoring system, will be automatically initialized. If this is done in a cold area the temperature reference value will be set accordingly and a too early temperature warning could occur (warning signal is temperature hoot = constant beep)!

After the first power up, the temperature reference value will adapt over time to the surrounding temperature and the adaptation routine happens every 5 hours (provided the CB is unused and connected to mains). The 5 hour counter (used by the temperature adaptation routine) will be reinitiated every time a handset/control panel is activated.

We therefore recommend that the CB is resting for min. 5 hours to adapt temperature wise to a 'normal operating' temperature, i.e. in the environment for intended use.



Recommendations

NOTE - HOT PLUGGING

Removing or adding any OpenBus cables is not allowed when the CB is powered by mains supply!

If needed anyway, follow the below procedure:

1. Remove mains and wait 5 sec.
2. Mount or dismount the required cables

If this procedure is NOT followed, it may result in a damaged OpenBus driver circuit.

The risk of a damaged circuit increases if the accessory has a high start current (in rush current).

OBF - hot-plugging protected from January 2016.



Precautions:

BATTERY OPERATION:

OBL and OBF:

- If the battery voltage is at 'low level' a battery alarm beeps constantly (Low level means that battery charging is necessary to maintain the best possible lifetime. Low level battery limit corresponds to approx. 19 V (+/- 5%).
- If the battery voltage is at 'critical level' the battery alarm function shuts down all operation immediately. (If trying to operate the system anyway, the battery could become deeply drained or the actuator system could be damaged. When at critical battery level there is a risk that the processor will incorrectly monitor end of stroke. Crashing the actuator could be a result. Critical level limit corresponds to approx. 17,5 V (+/- 5%).
- The CB6S with battery back-up only commences battery charging when it is connected to the mains.
- A battery stored at 25° C has to be recharged every 6-7 months.
- Prior to first use of LINAK batteries, please make sure that they are charged 24 for hours in order to reach proper function and prolong the lifetime of the batteries.
- The longest lifetime is obtained when the battery is fully charged.

IF BACKLIGHT SUPPORTED HB IS USED:

- When CB6S is powered by mains voltage:
 - At no operation of the HB the backlight in the HB is dimmed.
 - If a HB button is activated the backlight illuminates fully.When the HB button is released the light is dimmed again after approx. 10-15 sec.
- When CB6S is powered by battery:
 - At no operation of the HB there is no backlight in the HB.
 - If a HB button is activated the backlight illuminates fully.When the HB button is released the backlight turns off.

OBF

- More information about "OpenBus SW guidance", please contact your local LINAK.

Mounting of LA27/LA40 on OBF:

- It is not recommended to mount LA27/LA40 on OBF because of the big toroidal transformer used.

6. CB7 (HOMELINE®)

LINAK®
 WE IMPROVE YOUR LIFE
 DESIGNED IN DENMARK
 Item : CB70081011-0000
 Date : 2014.06.20 S.O.6145789
 U in : 24 V~ ±10 %, 50-60 Hz
 I in : Max. 5 A

Op. : Int. 10 %, Max. 2 min. / 18 min.
 NOT TO BE OPENED BY UNAUTHORIZED PERSONNEL
 NE PAS A OUVRIER PAR PERSONNEL NON-AUTORISE

P.0.2114579-0001 MADE BY LINAK A/S DENMARK

Compared to other LINAK control boxes the CB7 is very small and compact in design.

The CB7 is designed to slide onto an LA31 actuator for easy fitting e.g. in a recliner application where "mounting" space is limited.

The control box function is divided in two parts. The actual control box CB7, which slides onto the LA31 actuator and a separate external power supply transformer box TR6 or TR7, which can be wall mounted or placed on the floor moulding next to the mains.

The control box is only fitted with low voltage electronic components and the connection between the CB7 and transformer is via a 24 V power cable.

7. CB8A (MEDLINE® CARELINE® TECHLINE®)

LINAK®
 WE IMPROVE YOUR LIFE
 DESIGNED IN DENMARK
 Item : CB8002A44-00
 Date : 2016.01.09
 W/O # 1234567-0001
 MADE BY LINAK A/S DENMARK

Op. : 5% Max 3 min / 57 min

NOT TO BE OPENED BY UNAUTHORIZED PERSONNEL
 NE PAS OUVRIER PAR DU PERSONNEL NON-AUTORISE

CAUTION : NE PAS OUVRIER PAR DU PERSONNEL NON-AUTORISE

The CB8A is a battery powered control box operating up to 3 actuators individually. One of these channels can be used either as an external emergency stop device or for battery charging.

Simple design and high quality construction make the CB8A an ideal control box choice for mains-free operation of beds, chairs, tables and many other mobile applications.

Usage:

- Duty cycle: Max. 10% or 2 min. in use followed by 18 min. not in use
- Ambient temperatures: + 5° to +4 0° C
- Approvals: IEC60601-1:2005 3rd edition approved ANSI/AAMI, ES60601-1:2005 3rd edition approved.



Warning

In order to avoid injury, the emergency stop should be activated in (all) transport situations.



Recommendations

- Note: max. accumulated power consumption is 10 Amp.
- The measurement is individual for each channel, but if the total current consumption reaches 10 Amp, the CB cuts off the current. The CB and the actuator are therefore protected via a common measurement.
- External Charger CH01 has to be ordered separately. By use of charger CH01 it is possible to activate the actuators when charging. However, this is not recommended as it can damage the control box or the charger CH01.
- Battery kit BA0801 has to be ordered separately for versions M, G, H, Q, R (2 channel) and version M (3 channel).
- An external emergency stop device (NC) or short-circuiting connection must be mounted from channel 3 of CB800XXXXN-X0 before connection to allow proper function and battery charging.
- When using the CB8A with emergency stop button, the stop button must be released before charging batteries.
- Acoustic alarm sounds when batteries are low and recharging should be started. The alarm level corresponds to approx. 17-18 VDC.
- If the CB800XXXXN-X0 option is chosen, An external emergency stop device (NC) or short-circuiting connection must be mounted in channel 3, before connection to allow proper function and battery charging.
- If the option N for CH3 is chosen, the external emergency stop has to be placed on channel 3, otherwise the CB8A will not work.

Important: Individual current cut-off:

The current to each actuator is monitored and when this reaches a specified value, the current to that actuator is cut-off.

As the actuators do not have the same current consumption the cut-off values must also be different. Therefore it must be specified which actuator is to be connected to which channel:

CURRENT CUT-OFF (A)
2 A (2.35 +/- 0.35 Amp)
3 A (3.00 +/- 0.35 Amp)
4 A (4.00 +/- 0.50 Amp)
5 A (5.35 +/- 0.50 Amp)
6 A (5.90 +/- 0.70 Amp)

Values in brackets show tolerances.

8. CB8-T (MEDLINE® CARELINE® TECHLINE®)

LINAK® 

WE IMPROVE YOUR LIFE
DESIGNED IN DENMARK
Item : CB8002T22-0017
Date : 2016.01.09
W/O # 1234567-0001
MADE BY LINAK A/S DENMARK

U In : 230 V~ / 50 Hz
I In : Max. 0.63A
IPX5
Op. : 5%, max. 1 min. / 19 min.

120690

CAUTION : NOT TO BE OPENED BY UNAUTHORIZED PERSONNEL
NE PAS OUVRIER PAR DU PERSONNEL NON AUTORISE



The CB8-T is developed for use with LINAK A/S' actuators and handsets. The control box can operate up to 2 actuators individually.

The simple compact design combined with high quality makes the control box ideal for use with beds, chairs, tables and many other applications.

Important: Individual current cut-off:

The current to each actuator is monitored and when this reaches a specified value, the current to that actuator is cut-off.

As the actuators do not have the same current consumption the cut-off values must also be different. Therefore it must be specified which actuator is to be connected to which channel:

CURRENT CUT-OFF (A)
2 A (2.35 +/- 0.35 Amp.)
3 A (3.00 +/- 0.35 Amp.)
4 A (4.00 +/- 0.50 Amp.)
5 A (5.35 +/- 0.50 Amp.)
6 A (5.90 +/- 0.70 Amp.)

Values in brackets show tolerances.

9. CB9 (HOMELINE®)

LINAK® 

WE IMPROVE YOUR LIFE
DESIGNED IN DENMARK
Item : CB9000AK4+00000
Date : 2016.01.09
U In : 230V ~, 50/60 Hz
I In : Max. 1.5A

Int. : 10%, Max. 2 min./18 min.



NOT TO BE OPENED BY UNAUTHORIZED PERSONNEL
NE PAS OUVRIER PAR DU PERSONNEL NON AUTORISE

W/O #1234567-0001 MADE BY LINAK A/S DENMARK

The CB9 has been developed for Home use. The CB9 and the LA31 can be fully integrated, which saves mounting and wiring or be installed separately.

The HOMELINE CB9 series is available as either analogue (Ax) or μ -processor based (Px) types.

10. CB9 (MEDLINE® CARELINE®)

LINAK® 

WE IMPROVE YOUR LIFE
DESIGNED IN DENMARK
Item : CB9140AK4+00010
Date : 2016.01.09
U In : 230V ~, 50/60Hz
I In : Max. 1.5A
IPX4
Int. : 10%, Max. 2 min./18 min.



NOT TO BE OPENED BY UNAUTHORIZED PERSONNEL
NE PAS OUVRIER PAR DU PERSONNEL NON AUTORISE

W/O #1234567-0001 MADE BY LINAK A/S DENMARK

The CARELINE® CB9 has been developed for use together with LA31/LA31R, LA34/LA34R* in the Care & Rehab industry. CB9 and LA31 can be fully integrated which saves mounting and wiring or be installed separately.

Exchangeable mains cables, Electronic Overload Protection (EOP), EAS, earth connection (Class 1) and exchangeable mains fuse makes CB9 a good choice for the simple hospital and care beds.

Usage:

- Duty cycle: Max. 10% or 2 min. continuous use followed by 18 min. not in use
- Ambient temperature: + 5° to + 40°C
- Compatible with up to 4 actuators, type LA31/LA31R and LA34/LA34R, via 4-pole DIN sockets
- Compatible with BA18
- Medically approved according to EN 60601-1/UL 60601-1



Recommendations

LA34 fast motor is not compatible with any standard versions of CB9, due to high current consumption. For use of LA34 standard motor and small motor always use a CB9 with EAS.

Additionally, actuators with reed switch may not be connected to AC, AJ, AK, AF, AL or AM types because of a conflict between the CB-signal wires and the reed wires !

CB9 is equipped with a green LED for indication of mains power connected.

- When th CB9 is connected to mains, the LED is green.
- Connected only to battery, the LED is off.



The cables are locked in position with a locking mechanism.



The locking mechanism is showhere (not in position)

CB9 mounted on actuator, LA31.

CB9 for mounting on application.
Shows the two holes used for mounting

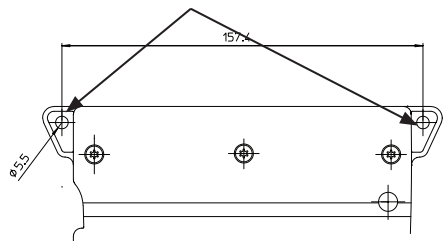

CB9 can be mounted and fixed together with LA31 with one screw.

11. CB9 CARELINE Basic (MEDLINE® CARELINE®)



WE IMPROVE YOUR LIFE
DESIGNED IN DENMARK
Item : CB9000PM4-N0000
Date : 2014.06.20 S.O.6145789
U In : 230V ~, 50/60 Hz
I In : Max. 1.5A

Int. : 10%, Max. 2 min./18 min.



NOT TO BE OPENED BY UNAUTHORIZED PERSONNEL
NE PAS OUVRIER PAR PERSONNEL NON-AUTORISÉ

P.O.2114579-0001 MADE BY LINAK A/S DENMARK

The CARELINE® Basic CB9 has been developed for use together with LA31 and LA34 in the Care & Rehab industry. CB9 and LA31 can be fully integrated thus saving mounting and wiring or they can be installed separately. Exchangeable mains cables, Electronic Overload Protection (EOP) and earth connection (Class 1) mains fuse makes CB9 a good choice for simple hospital and care beds. The CARELINE® Basic CB9 series is only available as an analogue (Ax) type.

Microprocessor:

With LINAK software packages the Px types are aimed at applications where parallel drive and/or memory functions are required. Please consult the ordering example for a detailed description of the article number.

Internal battery charger:

Compatible with BA18.

If anything other than a LINAK® charger is used, it must conform to the following specifications:

Charging voltage: 27.6 VDC ± 2% Charging current: < 300 mA.

EOP:

AC and AF: Means common measurement on CH1, CH2, CH3 and CH4. If the total current exceeds 5A all channels will be cut off.

AJ and AL: Means a common current measurement on CH1+2. The current will be cut off when the total current on both channels reaches approx. 3.4A and 7A on CH3+4.

Note: CH1+2 = LA31 connection and CH3+4 = LA31/LA34 connection.

AK and AM: Means common measurement on CH1, CH2, CH3 and CH4. If the total current exceeds 7A all channels will be cut off.

AS: Means an individual current measurement on CH1, CH2, CH3 and CH4. The current will be cut off only when the current on one channel reaches approx. 4A.

Max. current available from the CB9 transformer is approx. 7A.

Px: Means Electronic Overload Protection via a pulse measurement.

Usage:

- Duty cycle: Max. 10% or 2 min. continuous use followed by 18 min. not in use
- Ambient temperature: + 5° to + 40°C
- Compatible with up to 4 actuators, type LA31/LA31R and LA34/LA34R, via 4-pole DIN sockets
- Compatible with BA18
- Medically approved according to EN 60601-1/UL 60601-1 3rd Edition



Recommendations

The LA34 fast motor is not compatible with any standard versions of the CB9, due to high current consumption. For use of the LA34 standard motor and small motor always use a CB9 with EAS.

Additionally, actuators with reed switch may not be connected to AC, AJ, AK, AF, AL or AM types because of a conflict between the CB- signal wires and the reed wires !

12. CB12 (MEDLINE® CARELINE®)



Designed in Denmark
DK - 6430 Nordborg

Item : CB12E0003A0032A
Date : 2017.10.09
U In : 230 V ~, 50/60 Hz
I In : Max. 1.4 A IPX6
Int. : 10 %, Max. 2 min./18 min.



NOT TO BE OPENED BY UNAUTHORIZED PERSONNEL
NE PAS OUVRIER PAR DU PERSONNEL NON-AUTORISÉ

W/O #1234567-0001 MADE IN DENMARK

The CB12 product range features two standard versions, which are ideal for a vast number of medical and industrial applications.

In general the CB12 is a transformer operated control unit, which can control up to 4 actuators. The control box feature a range of built-in safety devices, increased current cut-off, EAS (Electronic Arc Suppression), and other options such as battery backup, earth outlet, wet alarm etc.

CB12 with battery backup

The CB12 with battery backup has an acoustic alarm, which sounds when the batteries are low, approx. 17 - 18V. To charge the batteries on a CB12 with internal batteries, just connect the CB12 to mains. With external batteries, connect the external batteries to an external charger.

External battery charger

If anything other than a LINAK® charger is used, it must conform to the following specifications:

Charging voltage: 27.6 VDC ± 2%

Charging current: < 300 mA.



Warning

In order to avoid injury, a system with control(s) or accessories, a CB12 with battery backup and actuators assembled, must always be disassembled in transport and service situations.

13. CB14 (MEDLINE® CARELINE® TECHLINE®)



WE IMPROVE YOUR LIFE

DESIGNED IN DENMARK

Item : CB14M0364AA140F 075044

Date : 2014.06.20 S.O.6145789

U In : 120 V~, 60 Hz

I In : Max. 3.5 A

IPX1

Int. : Int. 10 %, Max. 2 min. / 18 min.

S.W. P/N.: 0076362 Ver. 2.00



NOT TO BE OPENED BY UNAUTHORIZED PERSONNEL
NE PAS À OUVRIR PAR PERSONNEL NON-AUTORISÉ



P.O.2114579-0001 MADE BY LINAK A/S DENMARK

The CB14 with microprocessor is developed for systems with a need to run up to five actuators or two actuators / lifting columns in parallel and / or with memory function.

The effective toroidal transformer and the many features such as battery backup, earth outlet, wet alarm makes the control box suitable for a variety of applications.

CB14 with battery backup

The CB14 with battery backup has an acoustic alarm, which sounds when the batteries are low, approx. 17-18V. To charge the batteries on a CB14 with internal batteries, just connect the CB14 to mains. With external batteries, connect the external batteries to an external charger.

Memory position on CB14

When storing the memory position on CB14 the actuators must be run to the wanted position and the "store" button (S) must be pushed. Hereafter, the selected memory button (1, 2, or 3) must be activated within 2 seconds.

Microprocessor

All control boxes with a microprocessor must be initialized before start-up. A description of the initialisation procedure can be obtained from your LINAK dealer. If an actuator is replaced, the microprocessor always has to be initialised before use (actuators with reed/hall).

If re-programmed, please ensure that the correct software is used.

External battery charger

If anything other than a LINAK® charger is used, it must conform to the following specifications: Charging voltage: 27.6 VDC ± 2% Charging current: < 300 mA.



Warning

In order to avoid injury, a system with control(s) or accessories, a CB14 with battery backup and actuators assembled, must always be disassembled in transport and service situations.

14. CB16 (MEDLINE® CARELINE®)



WE IMPROVE YOUR LIFE

DESIGNED IN DENMARK

Item : CB16605+000020J

Date : 2016.01.09

W/O # 1234567 - 0001

MADE BY LINAK A/S DENMARK

U In : 230V~ 50/60 Hz / I In: Max. 2 A

Int. : 10% Max. 2 min / 18 min.

S.W.0078300 Ver.1.2 IPX6



CAUTION: NOT TO BE OPENED BY UNAUTHORIZED PERSONNEL

NE PAS À OUVRIR PAR DU PERSONNEL NON-AUTORISÉ



CB16 is part of the LINAK® OpenBus™ product range. It is a powerful control box with either traditional transformer solution or Switch Mode Power Supply. The universal Switch Mode Power Supply makes the control box adaptable to the worldwide market irrespective of the input voltage.

Usage:

- Approvals: CB160BF/OBL is approved according to IEC60601-1:2005 3rd ed., ANSI / AAMI ES60601-1:2005, 3rd edition, CAN / CSA-22.2 No 60601-1:2008.
- Compatibility: LA27 (no feedback/encoded feedback), LA31, LA34, LA43, LA44, BL1, and BL4
- Duty cycle: 10%, 2 minutes continuous use followed by 18 minutes not in use
- Usage temperature: 5°C to 40°C
- Storage temperature: - 10°C to 50°C



Recommendations

NOTE - HOT PLUGGING

Removing or adding any OpenBus cables are not allowed when the CB is powered by mains supply!

If needed anyway follow the below procedure:

1. Remove mains and wait 5 sec.
2. Mount or dismount the required cables

If this procedure is NOT followed it may result in a damaged OpenBus driver circuit.

The risk of a damaged circuit increases if the accessory has a high start current (in rush current).

NOTE - Use of internal mains signal in software or on OpenBus

Please note when using the internal mains signal on control boxes with SMPS that the mains signal may take up to 6 seconds before disappearing after mains has been removed.

Battery operation:

BATTERY LEVELS

Battery High: > 20 V - normal

Battery Medium: 18-20 V - alarm

Battery Low: < 18 V - critical

- If the battery voltage is at 'Medium level' a battery alarm beeps as long as a key is activated. (Medium level means that battery charging is necessary to maintain the best possible lifetime).
- If the battery voltage is at 'Low level', the battery alarm function shuts down all movement immediately. The OpenBus is still active for approx. 15 seconds. (If trying to operate the system anyway, the battery could get deep drained or the actuator system could get damaged. When at low battery level (which is critical), there is a risk that the processor will incorrectly monitor the end of stroke. Crashing the actuator could be a result).
- The CB16 with battery back-up only commences battery charging when it is connected to the mains.
- For more information about the batteries, please contact LINAK.

Before startup of CB16OBF

Due to the microprocessor in CB16OBF the control box has to be initialised before startup. Initialisation will in most cases be possible pressing H0 and H1 or H10 and H11 on a handset.

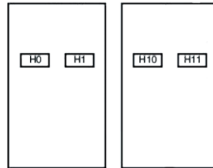

Initialisation depends upon the software description so please obtain a description of the initialisation procedure from your local LINAK dealer.

- If an actuator is replaced, the microprocessor always has to be initialised before use (actuators with reed / hall).
- If re-programmed please ensure that the correct software is used.



Precautions

If backlight supported HB is used:

- When CB16 OBL or OBF is powered by mains voltage:
 - At no operation of the HB the backlight in the HB is dimmed.
 - If an HB button is activated the backlight illuminates fully.
 - When the HB button is released the light is dimmed again after approx. 10-15 sec.
- When CB16 OBL or OBF is powered by battery:
 - At no operation of the HB there is no backlight in the HB.
 - If an HB button is activated the backlight illuminates fully.
 - When the HB button is released the backlight turns off.

1st failure safe monitoring:

- Failure indication:
 - all ACO LED's are blinking
 - The CB16 buzzer is shortly beeping if a handset is activated
 - The error can be reset by activating H0 and H1 OR H10 and H11 on a handset.

Compatibility – CB16 OBL:

- Using actuators with feedback on CB16 OBL are not supported. If used anyway it will not work properly. The reason is that feedback signals (e.g. Hall signals) is positioned at the same PINS as analogue stop signals - when using no feedback.

CB16OBF SMPS - Actuator combinations and/or customized software

- Due to the high power from the CB16OBF SMPS, it is highly recommended to validate the system to guarantee the lifetime of connected actuators. Especially when using customized software and/or actuator combinations which do not comply with the LINAK compatibility list - for further questions please contact your local LINAK contact.

15. CB20 (MEDLINE® CARELINE®)



WE IMPROVE YOUR LIFE
DESIGNED IN DENMARK
Item : CP2000000AA01009
Date : 2016.01.14
U In : 230 V~, 50/60 Hz
I In : 3 A
IPX4
Int. : Int. 10% Max. 2 min./18min.



CB20 is a platform which offers a unique safety concept, logging off service data and it is possible to connect a variety of accessories to the control box.

The CB20 consists of 3 modules :

CP20 = Control Power CU20 = Control Unit BA20 = Battery.



For recommendations on maintenance and storage of the BA20 battery packs, please refer to chapter 5.

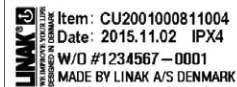

U In : ONLY LINAK CP20

Op. : 10%, max. 2 min / 18 min.

NOT TO BE OPENED BY UNAUTHORIZED PERSONNEL
NE PAS OUVRIER PAR DU PERSONNEL NON-AUTORISE



Usage:

- Compatible with specific versions of LA23, LA27C, LA31, LA34, LA40, LA43, LA44 and BL1
- Duty cycle: 10% - max. 2 min. continuous use followed by 18 min. not in use
- Ambient temperature: + 5° to + 40°C
- Approvals: IEC60601-1:2005 3rd ed., ANSI / AAMI ES60601-1:2005, 3rd edition, CAN/CSA-22.2 No 60601-1:2008 approved

Please be aware:

CB20 is delivered in 3 separate units - CU20 + CP20 + BA20. The units are not assembled at LINAK A/S.

Microprocessor

All control boxes with a microprocessor must be initialized before start-up. A description of the initialization procedure can be obtained from your LINAK dealer. If an actuator is replaced, the microprocessor always has to be initialized before use (actuators with reed/hall). If re-programmed, please ensure that the correct software is used.

External battery charger

If anything other than a LINAK® charger is used, it must conform to the following specifications: Charging voltage: 28.0 VDC ± 2% Charging current: < 300 mA.



Recommendations

- Please note mains cable must be ordered separately

HOT PLUGGING

Removing or adding any OpenBus™ cables are not allowed when the CB is powered by mains supply! If necessary anyway follow the below procedure:

1. Remove mains and wait 5 sec.
2. Mount or dismount the required cables

If this procedure is NOT followed it may result in a damaged OpenBus™ driver circuit. The risk of a damaged circuit increases if the accessory has a high start current (in rush current).

- Please note mains cable must be ordered separately.

Battery running:

- If battery capacity is under 50% a "bip" sound is given for 2 seconds, when a handset key is pressed.
- If the system is activated and the mains plug is pulled out, the system will stop. In the opposite case, if the system is running using battery power and the mains plug is then plugged in, the system will continue running.
- The charging indicator can blink if the system operates with a high load causing the voltage to drop and because of this the batteries will start to charge.
- The CB20 with battery back-up only commences battery charging when it is connected to the mains.
- A running battery must be charged for at least 12 hours before use.
- For recommendations on charging cycles and first use of the BA20 battery pack, please refer to chapter 5.

16. CBR1 (MEDLINE® CARELINE® HOMELINE®)



The CBR1 has been developed for use together with the RA40 Rotary actuator. The CBR1 can be installed in the same profile as the RA40 Rotary actuator thus saving mounting and wiring.

LINAK Designed in Denmark
DK - 6430 Nordborg

Type : CO4+09411X09000

Item : CO41



Date : 2016.07.12

U In : 100-240 V~, 50/60 Hz

I In : Max. 3.9 A

IPX6 Washable

Int. : 10%, max. 2 min. / 18 min.



W/O #-00001 ASSEMBLED IN CHINA

The LINAK control box CO41 offers a consolidated range of unprecedented features – all utilising standardised technology, interfaces and compatibility.

The CO41 for LINAK actuators is intended for the control of, for example, hospital bed movement.

Equipped with 120W SMPS, excellent and well thought-out cable management as well as multiple easy mounting options, this control box opens up a wide range of application possibilities for the provident hospital and care products manufacturer.

Features:

- Duty cycle: 10 % - 2/18 min. on/off continuous use.
Maximum power is 120 W for 80 seconds and 60 W for 40 seconds at 25 °C.

LED indicator

CO41 is equipped with a green LED for indication of mains power connected.

When the CO41 is connected to mains, the LED is green. Connected only to battery, the LED is off.

Connected to MAINS

LED colour	Indication of operation
Green	On mains, <u>not</u> activated by hand or foot control. The system is working ok and is ready for normal operation.
Yellow	On mains, <u>not</u> activated by hand or foot control. The system is defective and should not be operated.
Yellow	On mains, <u>activated</u> by hand or foot control. The system is working.

Not connected to mains but with BATTERY back-up

LED colour	Indication of operation
Orange	On battery, <u>activated</u> by hand or foot control. The system is working.
No LED	On battery, <u>not</u> activated by hand or foot control. or CO41 not connected to mains.

Acoustic signal functionality:

The buzzer will make a warning, when a button on the hand control is pressed, and the battery capacity is low.

The buzzer can also be activated by the control box to signal other conditions. This must be specified in the control box software.

CO41 - mounted on frame:

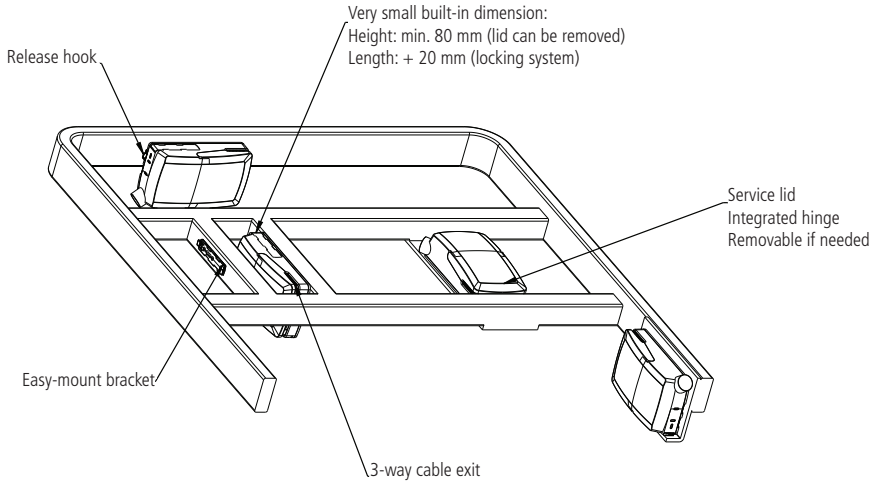

Mounting bracket (frame flat)
- article No. 1015W1001:

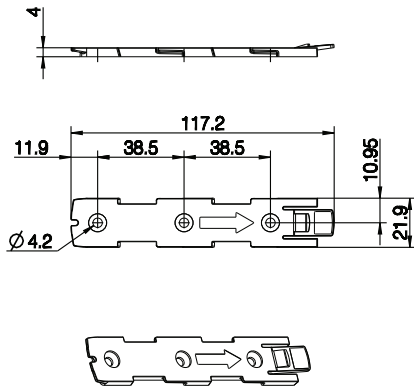

Mounting bracket (frame flat) w/M4 nuts
- article No. 1015W1009:

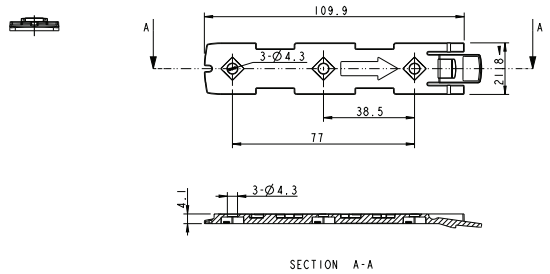

Mounting instructions (Example CO41 with LA40)

When mounting the control box onto the actuator (1)

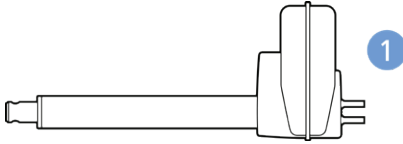

Simply slide on the bracket until you hear a clear click (2)

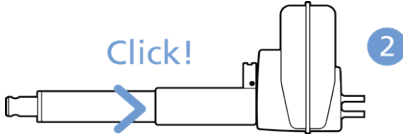

Slide on the control box until you hear a click and the box is mounted (3)

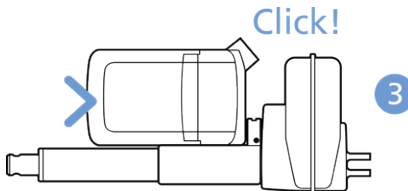

It is recommended that the CO41 is mounted in a position that allows water to escape.

Recommended torque: 0.6 Nm +/-0.1

The bracket can be mounted to the bed frame or any other application by following one of the following mounting procedures:

- 1) M6 nut to be placed in bracket and fixed with M6 bolt from the rear side.
- 2) M5 machine screw with flat washer to be fixed through bracket with nut on the rear side.
- 3) Self-tapping screw to be placed through bracket and onto the frame.

Mounting of cables and cable lock:

CO41 has a uniquely designed cable lid. The lid also works as an integrated cable lock when closed.

- 1) Mount cable plugs in control box
- 2) Close lid until lock snaps into place (see arrows)

To allow free access to the cables, the lid has a rest position when completely opened.

It is possible to remove the lid by lifting it a few degrees and pulling it away from the housing under tight mounting conditions.

See illustrations:

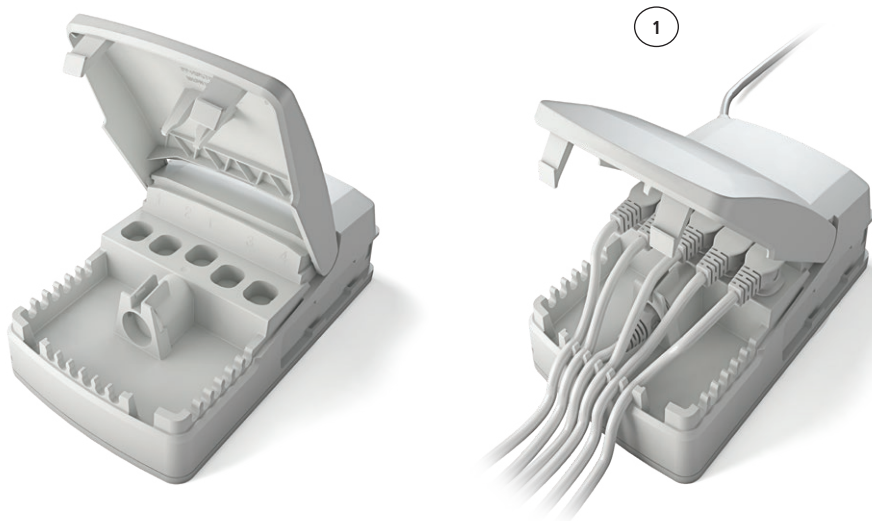

Cable management:

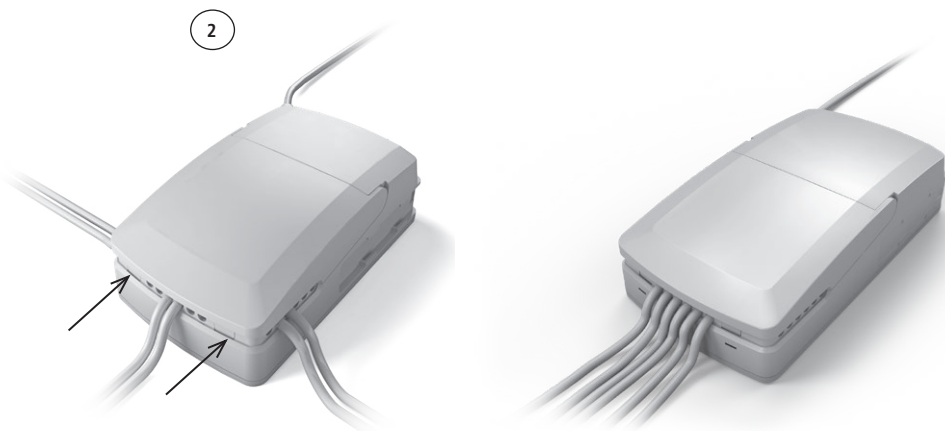



Recommendations

- To avoid that hand control cables short-circuit, LINAK recommends to use an OpenBus system (CO41).
- When the system is overloaded, LINAK recommends to use quick release actuators in the application. These will allow functions to be lowered manually in case of a CO41 malfunction due to misuse/abuse.
- If the customer has other essential performance than “*no unintended movement*”, he must consider this in his own risk analysis. LINAK disclaims any liability.
- If the actuator or the control cable is removed from the control box, the cable lock must be applied. To ensure movement in this case, LINAK recommends to use quick release actuators in the application.
- If the cable is damaged by pulling, LINAK recommends to make a safe cabling. If movement is an essential performance, LINAK recommends to apply quick release actuators, for example, to ensure movement.
- If the thermal protection is activated due to current overload when operating multiple actuators and/or excessive duty cycle, the operation must be kept within the specification. If movement is an essential performance, LINAK recommends to apply quick release actuators, for example, to ensure movement.
- Sales must request a review of the products according to current cut-off limits.

Motor cable

Always use 6-wire cables.

Please note that angled motor cable plugs are required for connection to the control box.

Because of the half-bridge technology used in CO41 there is an interdependence between each half-bridge, CH1 + 2 and CH3 + 4. Half-bridge connected channels cannot run simultaneously in opposite directions. E.g. running a trend function using CH3 and CH4 will not be possible.



Warnings

- Use EPR or ensure that the user takes care not to squeeze the mains cable.
- Always check correct assembly after mounting and service to ensure that the cable lock is mounted. (Connectors are usually removed during cleaning)
- Always use approved chemicals with the housing as the plastic may show corrosion caused by some chemicals. As a result water may accumulate/gather in housing.
- Take special precautions concerning 3rd party interfacing. Please contact LINAK for further information.
- Make a review of all product specifications before system set-up if the current cut-off limit is higher than the maximum allowed current cut-off for the actuator.
- To avoid cable interruption and actuator defects make a proper cable installation and inspect regularly for wear and damage. Defective parts must be replaced.
- After service inspection, the application must be tested for correct functionality before it is put into operation to avoid actuator plugs being mixed during service. Operators must not be inside entrapment area.
- To avoid electrical failure or system disturbance inspect regularly for wear and damage. Defective parts must be replaced.
- Make a proper cable installation to avoid short-circuit cables for handset/controls. Regular inspection must be made for wear and damage. Defective parts must be replaced.

LINAK Designed in Denmark
DK - 6430 Nordborg

Type : CO6+09421T09000

Item : CO61



Date : 2016.07.12

U In : 100-240 V~, 50/60 Hz

I In : Max. 3.9 A

IPX6 Washable

Int. : 10%, max. 2 min. / 18 min.



W/O #-00001 ASSEMBLED IN CHINA

The LINAK control box CO61 offers a consolidated range of unprecedented features – all utilising standardised technology, interfaces and compatibility.

The CO61 for LINAK actuators is intended for the control of, for example, hospital bed movement. Equipped with 200W SMPS, excellent and well thought-out cable management as well as multiple easy mounting options, this control box opens up a wide range of application possibilities for the provident hospital and care products manufacturer.

Features:

- Duty cycle: 10 % - 2/18 min. on/off continuous use.
Maximum power is 200 W for 80 seconds and 100 W for 40 seconds at 25° C.

LED indicator

CO61 is equipped with a green LED for indication of mains power connected.

When the CO61 is connected to mains, the LED is green. Connected only to battery, the LED is off.

Connected to MAINS

LED colour	Indication of operation
Green	On mains, <u>not</u> activated by hand or foot control. The system is working ok and is ready for normal operation.
Yellow	On mains, <u>not</u> activated by hand or foot control. The system is defective and should not be operated.
Yellow	On mains, activated by hand or foot control. The system is working.

Not connected to mains but with BATTERY back-up

LED colour	Indication of operation
Orange	On battery, activated by hand or foot control. The system is working.
No LED	On battery, <u>not</u> activated by hand or foot control. or CO61 not connected to mains.

Acoustic signal functionality:

The buzzer will make a warning, when a button on the hand control is pressed, and the battery capacity is low.

The buzzer can also be activated by the control box to signal other conditions. This must be specified in the control box software.

CO61 - mounted on frame:

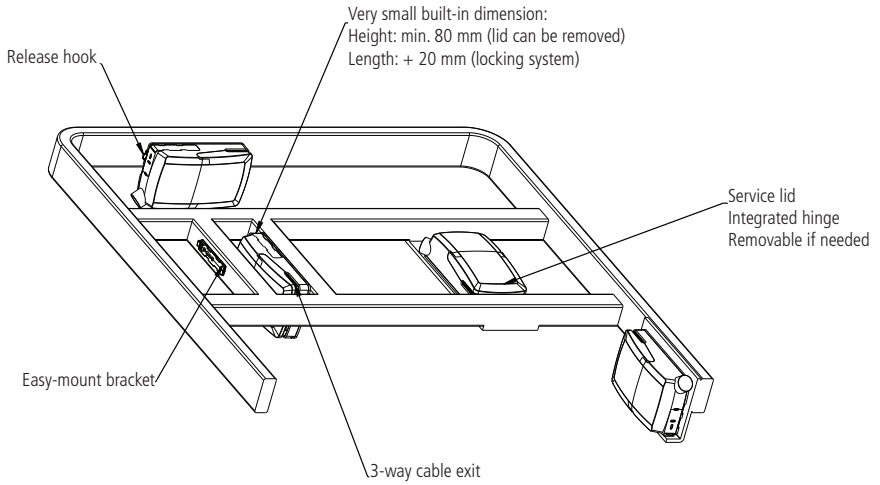

Mounting bracket (frame flat)
- article No. 1015W1001:

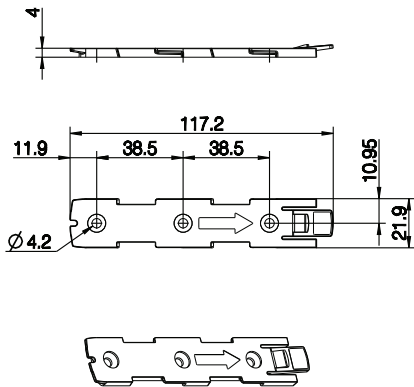

Mounting bracket (frame flat) w/M4 nuts
- article No. 1015W1009:

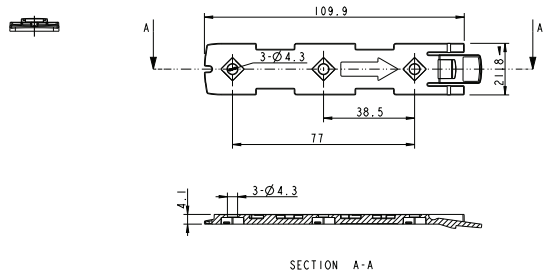

Mounting instructions (Example CO61 with LA40)

When mounting the control box onto the actuator (1)

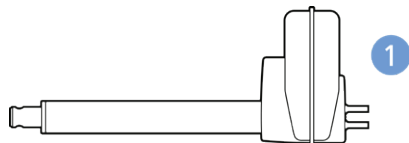

Simply slide on the bracket until you hear a clear click (2)



Slide on the control box until you hear a click and the box is mounted (3)

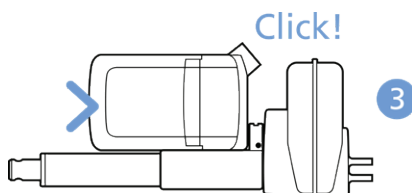

It is recommended that the CO61 is mounted in a position that allows water to escape.

Recommended torque: 0.6 Nm +/-0.1

The bracket can be mounted to the bed frame or any other application by following one of the following mounting procedures:

- 1) M6 nut to be placed in bracket and fixed with M6 bolt from the rear side.
- 2) M5 machine screw with flat washer to be fixed through bracket with nut on the rear side.
- 3) Self-tapping screw to be placed through bracket and onto the frame.

Mounting of cables and cable lock:

CO61 has a uniquely designed cable lid. The lid also works as an integrated cable lock when closed.

- 1) Mount cable plugs in control box
- 2) Close lid until lock snaps into place (see arrows)

To allow free access to the cables, the lid has a rest position when completely opened.

It is possible to remove the lid by lifting it a few degrees and pulling it away from the housing under tight mounting conditions.

See illustrations:

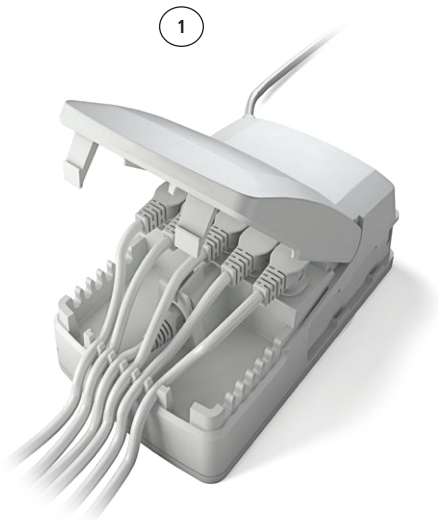

Cable management:

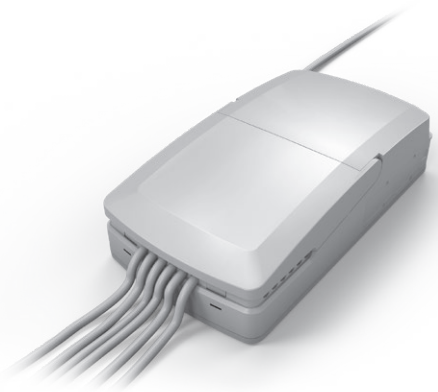
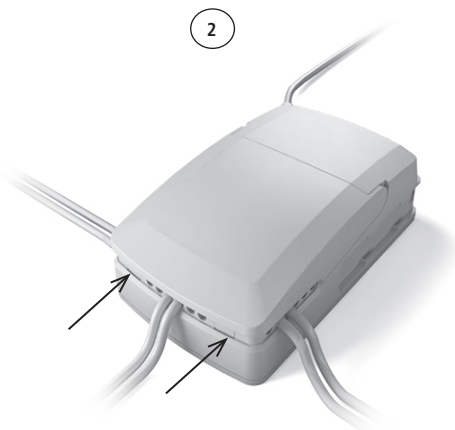



Recommendations

- To avoid that hand control cables short-circuit, LINAK recommends to use an OpenBus system (CO61).
- When the system is overloaded, LINAK recommends to use quick release actuators in the application. These will allow functions to be lowered manually in case of a CO61 malfunction due to misuse/abuse.
- If the customer has other essential performance than “*no unintended movement*”, he must consider this in his own risk analysis. LINAK disclaims any liability.
- If the actuator or the control cable is removed from the control box, the cable lock must be applied. To ensure movement in this case, LINAK recommends to use quick release actuators in the application.
- If the cable is damaged by pulling, LINAK recommends to make a safe cabling. If movement is an essential performance, LINAK recommends to apply quick release actuators, for example, to ensure movement.
- If the thermal protection is activated due to current overload when operating multiple actuators and/or excessive duty cycle, the operation must be kept within the specification. If movement is an essential performance, LINAK recommends to apply quick release actuators, for example, to ensure movement.
- Sales must request a review of the products according to current cut-off limits.

Motor cable

Always use 6-wire cables.

Please note that angled motor cable plugs are required for connection to the control box.



Warnings

- Use EPR or ensure that the user takes care not to squeeze the mains cable.
- Always check correct assembly after mounting and service to ensure that the cable lock is mounted. (Connectors are usually removed during cleaning)
- Always use approved chemicals with the housing as the plastic may show corrosion caused by some chemicals.
As a result water may accumulate/gather in housing.
- Take special precautions concerning 3rd party interfacing. Please contact LINAK for further information.
- Make a review of all product specifications before system set-up if the current cut-off limit is higher than the maximum allowed current cut-off for the actuator.
- To avoid cable interruption and actuator defects make a proper cable installation and inspect regularly for wear and damage. Defective parts must be replaced.
- After service inspection, the application must be tested for correct functionality before it is put into operation to avoid actuator plugs being mixed during service. Operators must not be inside entrapment area.
- To avoid electrical failure or system disturbance inspect regularly for wear and damage. Defective parts must be replaced.
- Make a proper cable installation to avoid short-circuit cables for handset/controls. Regular inspection must be made for wear and damage. Defective parts must be replaced.
- Do not mount the actuator with the spindle facing downwards to avoid that the actuator slips off the bracket with mounted control box. The bracket can come loose when exposed to shock or hard vibration, for instance when passing doorsteps. Regular inspection must be made to ensure proper fixation of control box and bracket on actuator.



Designed in Denmark
DK - 6430 Nordborg

Type : CO7+19431X29000

Item : CO71



Date : 2016.07.12

U In : 100-240 V~, 50/60 Hz

I In : Max. 3.9 A

IPX6 Washable

Int. : 10%, max. 2 min. / 18 min.



W/O #-00001 ASSEMBLED IN CHINA

The LINAK control box CO71 offers a consolidated range of unprecedented features – all utilising standardised technology, interfaces and compatibility.

The CO71 for LINAK actuators is intended for the control of, for example, hospital bed movement.

Equipped with 350W SMPS, excellent and well thought-out cable management as well as multiple easy mounting options, this control box opens up a wide range of application possibilities for the provident hospital and care products manufacturer.

Features:

- Duty cycle: 10 % - 2/18 min. on/off continuous use.
Maximum power is 350 W for 80 seconds and 175 W for 40 seconds at 25 °C.

LED indicator



CO71 is equipped with a green LED for indication of mains power connected.

When the CO71 is connected to mains, the LED is green. Connected only to battery, the LED is off.

Connected to MAINS	
LED colour	Indication of operation
Green	On mains, <u>not</u> activated by hand or foot control. The system is working ok and is ready for normal operation.
Yellow	On mains, <u>not</u> activated by hand or foot control. The system is defective and should not be operated.
Yellow	On mains, <u>activated</u> by hand or foot control. The system is working.

Not connected to mains but with BATTERY back-up	
LED colour	Indication of operation
Orange	On battery, <u>activated</u> by hand or foot control. The system is working.
No LED	On battery, <u>not</u> activated by hand or foot control. or CO71 not connected to mains.

Acoustic signal functionality:

The buzzer will make a warning, when a button on the hand control is pressed, and the battery capacity is low.

The buzzer can also be activated by the control box to signal other conditions. This must be specified in the control box software.

CO71 - mounted on frame:

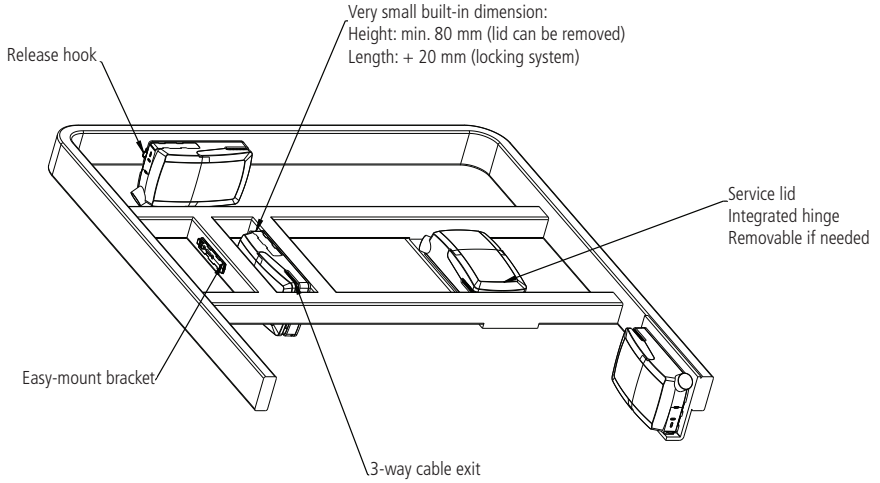

Mounting bracket (frame flat)
- article No. 1015W1001:

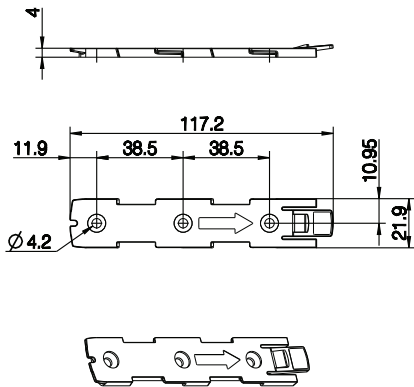

Mounting bracket (frame flat) w/M4 nuts
- article No. 1015W1009:

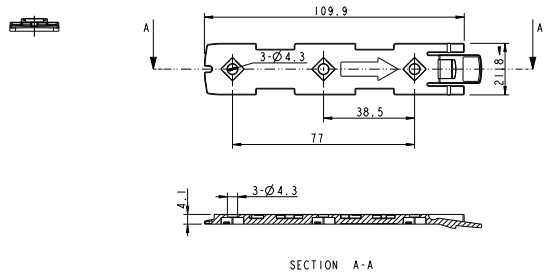

Mounting instructions (Example CO71 with LA40)

When mounting the control box onto the actuator (1)

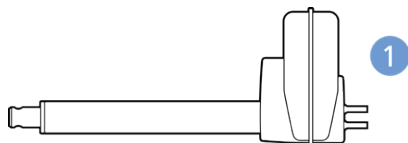

Simply slide on the bracket until you hear a clear click (2)



Slide on the control box until you hear a click and the box is mounted (3)

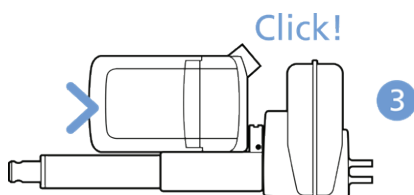

It is recommended that the CO71 is mounted in a position that allows water to escape.

Recommended torque: 0.6 Nm +/-0.1

The bracket can be mounted to the bed frame or any other application by following one of the following mounting procedures:

- 1) M6 nut to be placed in bracket and fixed with M6 bolt from the rear side.
- 2) M5 machine screw with flat washer to be fixed through bracket with nut on the rear side.
- 3) Self-tapping screw to be placed through bracket and onto the frame.

Mounting of cables and cable lock:

C071 has a uniquely designed cable lid. The lid also works as an integrated cable lock when closed.

- 1) Mount cable plugs in control box
- 2) Close lid until lock snaps into place (see arrows)

To allow free access to the cables, the lid has a rest position when completely opened. It is possible to remove the lid by lifting it a few degrees and pulling it away from the housing under tight mounting conditions.

See illustrations:

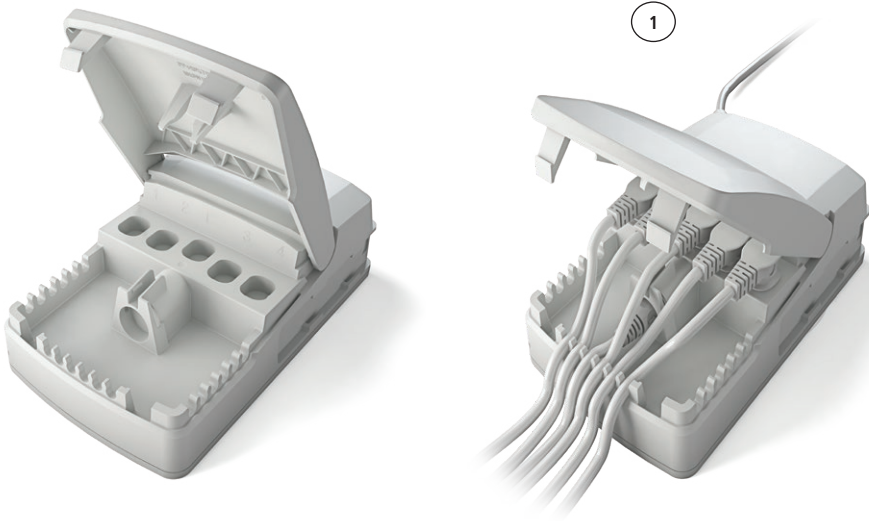

Cable management:

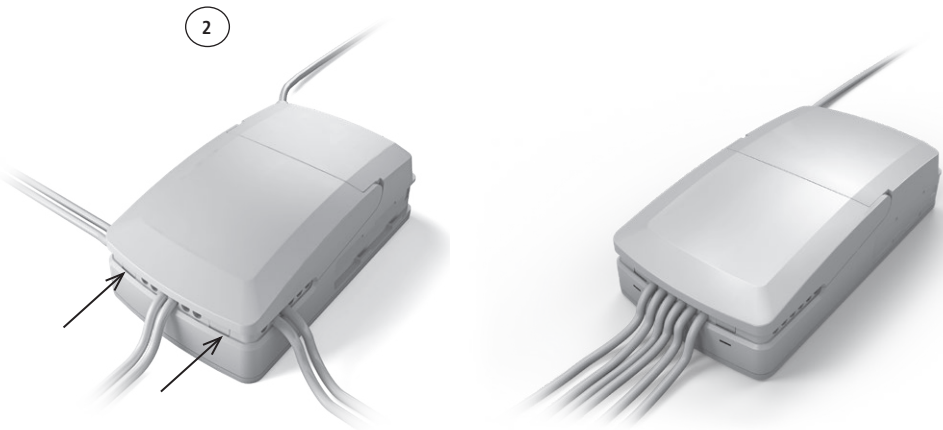



Recommendations

- To avoid that hand control cables short-circuit, LINAK recommends to use an OpenBus™ system (CO71).
- When the system is overloaded, LINAK recommends to use quick release actuators in the application. These will allow functions to be lowered manually in case of a CO71 malfunction due to misuse/abuse.
- If the customer has other essential performance than “no unintended movement”, he must consider this in his own risk analysis. LINAK disclaims any liability.
- If the actuator or the control cable is removed from the control box, the cable lock must be applied. To ensure movement in this case, LINAK recommends to use quick release actuators in the application.
- If the cable is damaged by pulling, LINAK recommends to make a safe cabling. If movement is an essential performance, LINAK recommends to apply quick release actuators, for example, to ensure movement.
- If the thermal protection is activated due to current overload when operating multiple actuators and/or excessive duty cycle, the operation must be kept within the specification. If movement is an essential performance, LINAK recommends to apply quick release actuators, for example, to ensure movement.
- Sales must request a review of the products according to current cut-off limits.

Motor cable

Always use 6-wire cables.

Please note that angled motor cable plugs are required for connection to the control box.



Warnings

- Use EPR or ensure that the user takes care not to squeeze the mains cable.
- Always check correct assembly after mounting and service to ensure that the cable lock is mounted. (Connectors are usually removed during cleaning)
- Always use approved chemicals with the housing as the plastic may show corrosion caused by some chemicals. As a result water may accumulate/gather in housing.
- Take special precautions concerning 3rd party interfacing. Please contact LINAK for further information.
- Make a review of all product specifications before system set-up if the current cut-off limit is higher than the maximum allowed current cut-off for the actuator.
- To avoid cable interruption and actuator defects make a proper cable installation and inspect regularly for wear and damage. Defective parts must be replaced.
- After service inspection, the application must be tested for correct functionality before it is put into operation to avoid actuator plugs being mixed during service. Operators must not be inside entrapment area.
- To avoid electrical failure or system disturbance inspect regularly for wear and damage. Defective parts must be replaced.
- Make a proper cable installation to avoid short-circuit cables for handset/controls. Regular inspection must be made for wear and damage. Defective parts must be replaced.
- Loss of mains: If the power supply is switched off for a short time (between 1 and approx. 1.5 seconds), the control box will only start up again if a key is pressed. This is only relevant for OpenBus™ systems that run continually
- Do not mount the actuator with the spindle facing downwards to avoid that the actuator slips off the bracket with mounted control box. The bracket can come loose when exposed to shock or hard vibration, for instance when passing doorsteps. Regular inspection must be made to ensure proper fixation of control box and bracket on actuator.

- **IC Statement:**
This device contains licence-exempt transmitter(s)/receiver(s) that comply with Innovation, Science and Economic Development Canada's licence-exempt RSS(s). Operation is subject to the following two conditions:
(1) This device may not cause interference.
(2) This device must accept any interference, including interference that may cause undesired operation of the device.

L'émetteur/récepteur exempt de licence contenu dans le présent appareil est conforme aux CNR d'Innovation, Sciences et Développement économique Canada applicables aux appareils radio exempts de licence. L'exploitation est autorisée aux deux conditions suivantes :

- (1) L'appareil ne doit pas produire de brouillage;
- (2) L'appareil doit accepter tout brouillage radioélectrique subi, même si le brouillage est susceptible d'en compromettre le fonctionnement.

- **FCC ID Statement:**
NOTE: This equipment has been tested and found to comply with the limits for a Class B digital device, pursuant to part 15 of the FCC Rules. These limits are designed to provide reasonable protection against harmful interference in a residential installation. This equipment generates uses and can radiate radio frequency energy and, if not installed and used in accordance with the instructions, may cause harmful interference to radio communications. However, there is no guarantee that interference will not occur in a particular installation. If this equipment does cause harmful interference to radio or television reception, which can be determined by turning the equipment off and on, the user is encouraged to try to correct the interference by one or more of the following measures:
- Reorient or relocate the receiving antenna.
- Increase the separation between the equipment and receiver.
- Connect the equipment into an outlet on a circuit different from that to which the receiver is connected.
- Consult the dealer or an experienced radio/TV technician for help

Changes or modifications not expressly approved by the party responsible for compliance could void the user's authority to operate the equipment.

This device complies with Part 15 of the FCC Rules. Operation is subject to the following two conditions: (1) This device may not cause harmful interference, and (2) this device must accept any interference received, including interference that may cause undesired operation.

6. Information on specific controls

1. ACC (MEDLINE® CARELINE®)



The ACC (Attendant Control Compact) is fitted to advanced hospital and patient care beds for use where patient positioning must be carefully controlled by medical staff.

2. ACK (MEDLINE® CARELINE®)

With the OpenBus™ system it is possible to use keypads as attendant control or hand controls integrated in the bed side rails.

Features and Options:

- Straight cables: 1250, 1800 or 2500 mm
- The standard ACK colour is grey (RAL 7035)

Usage:

- Operation temperature: +5 °C to +40 °C
- Storage temperature: -10 °C to +50 °C
- Compatibility: LINAK OpenBus™ control boxes

For LINAK Standard ACK's, the following is applicable:

- Adhesive for the standard ACK is 3M 468MP
- For information re. suitable and unsuitable surfaces, please see 3M's webpage
- Standard recommendation for curing time is 72 hours
- The customer is responsible for correct mounting on suitable surfaces

For datasheets and additional informations regarding the adhesives: www.3M.com

For Customised ACK's, the following is applicable:

Dependant on the customer's own design, installation, application and test it is possible to improve the IP protection class by the use of a special ACK introducing an extra sealing ring to avoid ingress. Mounting and curing times depend on the customer application.



Recommendations

- The customer responsibility includes making a proper design of the cable strain relief inside the side rail panel.
- The customer should consider and ensure to use the correct flammability classification when defining and specifying the housing. According to IEC 60601-1. Minimum HB plastic.
- The customer should consider the existence of vibrations when defining and specifying the housing, i.e. we recommend the customer to carry out a vibration test on the final product.
- The customer must ensure a proper IP rating/test
- The customer must ensure proper drop testing according to IEC60601-2-52 §201.15.3.4.1. In this clause there is an additional reference to IEC60601-2-31:2008.
- The customer is responsible for correct mounting of the PCBA. Among other things, it means
 - ensuring proper and safe mounting of the PCBA into ex. the side rail
 - ensuring proper and correct mounting between key pad connection tails and the ACK PCBA
 - ensuring proper and correct mounting of the key pad
 - the customer should consider proper precautions against ESD (Electrostatic discharge).
- When handling ESDS (Electrostatic Discharge Sensitive) devices – e.g. during transport, storage, handling, production or mounting in an application - exposure to harmful ESD must be avoided.
- Consider proper creepage and clearance measures to fulfil IEC 60601. With One MOPP (One Means Of Patient Protection / Secondary side of the actuator system) requirements are:
 - creepage distance = 2 mm / air clearance = 1 mm (Working voltage V d.c. up to and including)
- It is not recommended to dismount the keypad after mounting because it gives a high risk of failing key press.

3. ACL (MEDLINE® CARELINE®)

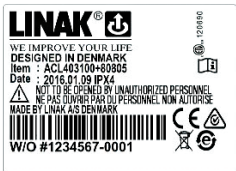

The ACL (Attendant Control Lock) box is a one turn button box fitted to hospital and care beds for use where the patient positioning must be carefully controlled by the medical staff.

The ACL disconnects all functions on some handsets.

4. ACM (MEDLINE® CARELINE®)



The ACM (Mini Attendant Control) box is fitted to hospital and care beds for use where patient positioning must be carefully controlled by the medical staff.

The compact design and simple operation makes it easy for the nursing staff to retain direct control over critical positioning functions whilst giving the patient a limited degree of adjustment.

The ACM must be mounted correctly on a flat surface to ensure IP degree. A short circuit in the cable can cause movement. To possibly avoid this risk, choose a OpenBus system.

5. ACO (MEDLINE® CARELINE®)



The ACO (Attendant Control OpenBus™) is a cost optimised and compact unit with up to 15 buttons that can be used as Handset keys or lock-outs. The lock-out function can be made visible by using yellow LED's. The ACO is compatible with control boxes that use an OpenBus interface i.e. CB6S, CB16 and CB20.

Usage:

- Compatible with OpenBus™ e.g. CB20, CB6S and CB16.
- Ambient temperature: +5° to + 40°C
- Approvals: IEC 60601-1 Edition 3.1 (2012)
IEC 60601-1-6:2010 + A1:2013,
ANSI/AAMI ES60601-1: A1:2012, C1:2009(R) 2012 and A2:2010(R)2012,
CAN/CSA-C22.2 NO. 60601-1:14
- Current consumption: 15 mA (Standard versions with 5 no. LEDs (5 LEDs x 2 mA = 10 mA)
+ microprocessor 5 mA, total = 15 mA)

In order to comply with the norm, the ACO must hang vertically from its hook during the washing process.



Recommendations

- Always use Locking ring and cables with O-rings.
- Locking ring and cables with O-rings must be fitted to ensure IP degree.
- If other front covers than standards are requested, the customer must design them.

N.B.

- Cables are inclusive an O-ring.

6. ACOM (MEDLINE® CARELINE®)



ACOM is the obvious control for hospital and nursing home beds where patient positioning needs careful control by medical staff. ACOM is an OpenBus™ control.

Usage:

- Operation temperature: +5 °C to + 40 °C
- Storage temperature: -10 °C to + 50 °C
- Relative humidity: 20 % to 80 % at +30° C, non-condensing
- Atmospheric pressure: 700 to 1060 hPa
- Approvals: IEC 60601-1 Edition 3.1 (2012), IEC 60601-1-6:2010 + A1:2013
- Compatibility: Compatible with LINAK OpenBus control boxes, CO-generation



Recommendations

- Clean the hand control regularly to ensure good hygiene standards.
- When a defective ACOM is replaced, check that the new ACOM has exactly the same specification and functionality.
- Do not submerge the hand control in water.
- Unless otherwise specified or agreed with LINAK, the hand control is only intended to be used for LINAK systems.
- When changing hand controls for OpenBus systems, the power must be switched off.
- It is recommended to check the hand control and cable for damage and holes caused by violent handling before washing the application or at least once a year.
- It is recommended to have a parking place for the hand control on the application where the customer ensures that the hand control does not fall off.



Warnings:

- Do not sit or lie on the hand control as this can cause unintended movement of the application.

7. ACP (MEDLINE® CARELINE®)



The ACP (Attendant Control Panel) controller is fitted to advanced hospital and patient care beds for use where patient positioning must be carefully controlled by medical staff.

The ACP allows nursing staff to retain direct control over critical positioning functions while giving the patient a limited degree of adjustment.

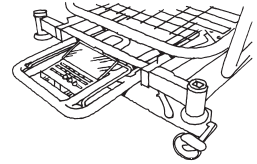

It is recommended to clean all surfaces, also surfaces covered by lids and the inside of the lids.
(In the event that the ACP is cleaned in wash tunnels; be aware that surfaces covered by lids and the inside of lids will not be cleaned)

8. ACT (MEDLINE® CARELINE®)

The Attendant Control Touch (ACT) for the hospital and care segment is a control panel with an intuitive, graphical three-level user interface:

1. Care mode for caregivers and relatives (bed operation)
2. Extended care mode for caregivers (locking function, settings etc.)
3. Service mode for technicians (advanced settings)

Usage:

- Operation temperature: +5°C to + 40°C
- Storage temperature: -10°C to + 50°C
- Relative humidity: 20% to 80%
- Atmospheric pressure: 700 to 1060 hPa
- Approvals: IEC60601-1:2005 3rd edition
ANSI/AAMI ES60601-1:2005 3rd edition
CAN/CSA-22.2 No 60601-1:2008
- Compatibility: All OpenBus™ control boxes except CB60BL

Mounting instructions:

The ACT must be mounted on the bed, for example on the footboard - illustration of the fitting is shown below.

The ACT must be supported on the back of the housing when fastening it to the mounting plate and not only supported on the edge of the housing front side.

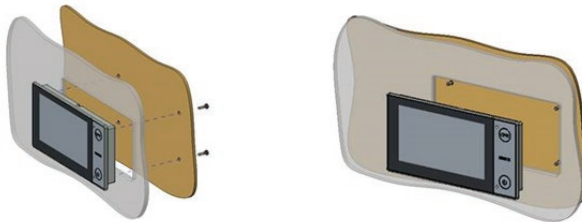

When mounting:

- LINAK recommends to use a self-tapping screw, BN84229, 50x12.
- Please observe that the 1.5 [Nm] screw torque limit is not exceeded.
- Please be aware that the screw holes in the ACT are only 11 mm deep. Use appropriate screws.
- Please ensure that the mounting leaves space (2 mm) between the ACT and the back of the housing. This to avoid that water is trapped. The space is only necessary where the membrane is placed on the ACT.
- If upward cable exit is used, mount a ferrite core to the cable (see section "Ferrite core").

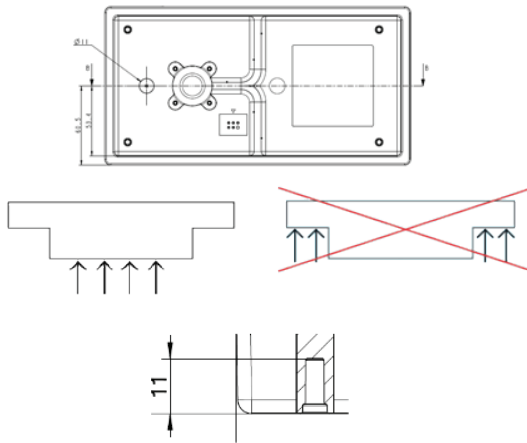

The recommended screw type is self-tapping BN84229 50 x 12.

A grounding cable (article no.: 1009W7004) will be supplied together with the ACT and must be connected to the OpenBus™ system and the other end to the bed frame to decouple electrical fields.

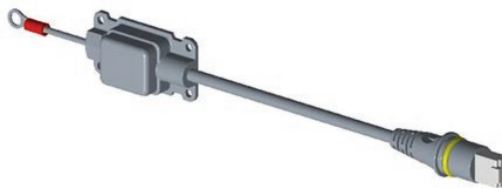

Ferrite core :

If upward cable exit is used, a ferrite core needs to be added as close as possible to the ACT.

Ferrite core specification:

At the mentioned frequencies, the impedance must be as stated in the table:

Frequency (MHz)	10	25	100	250
Impedance (Ω)	95	156	260	270

Ferrite core graphic characteristics:

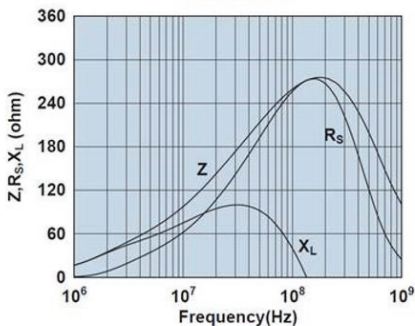

Impedance, reactance, resistance vs. frequency



Technical recommendations:

- Always use the cable locking mechanism and an O ring.
- Prepare a system/bit overview as the unit may conflict with other OpenBus™ accessories such as HB, ACP etc.
- Avoid large metal parts in the vicinity of the RFID reader (approx. 50 mm).
- When designing the application, be aware of the ACT position in the application to avoid impact to the front glass.
- Allow for a power consumption of max. 200 mA on both V-Bus and Vpermanent when designing a system.
- Use a LINAK magnet or a magnet with a minimum strength of 15 mT measured at a distance of 10 mm.
- Do not bend the cable more than the minimum bending radius of 10 mm when mounting the ACT in side rails or similar where the cable is repeatedly bent.
- Before first start-up, be aware not to place any magnetic devices or RFID tags in front of the company logo until the ACT goes into sleep mode to avoid calibration disturbance. (see start-up description under Functionality).
- Be aware that magnetic jewellery or magnets in general can activate care mode and lead to unintended use. LINAK recommends to use RFID tags.



Warnings:

- The application manufacturer must write an end-user manual based on the LINAK user manual which also includes relevant warnings, information on how to carry out regular inspection and a functionality description. End-users must be trained in all functions.
- Regular system inspections for wear or damage must be made.
- Mains and battery power must be disconnected before servicing.
- The magnet key cannot wake up a system in power-down mode or a system running on battery. The system will wake up when activating a key and the magnet key can then unlock the system.

9. DPH Medical (MEDLINE® CARELINE®)

The DPH is a small two button panel for adjustment of different functions. The DPH fits into a MJB with a modular plug and thereby compatible with OpenBus.

Usage:

- Ambient temperature: +5° to +40°
- DPH is compatible with the OpenBox control boxes via Modular Junction Boxes MJB5061101-00 as follows:

Control Boxes:	CB6S OBL, CB6S OBM, CB6S OBF, CB16 OBL, CB16 OBF, CB20
Modular Junction Box:	MJB5061101-00
- DPH1K10-210007 combined with MJB5061101-00 creates the OpenBus codes:

Up Arrow:	H0
Down Arrow:	H1
- Wrong mounting is not an issue with the MJB5061101-00 and the modular jack plug of the DPH cable. The plug will only fit into the correct ports of the MJB.

LINAK®  

WE IMPROVE YOUR LIFE
DESIGNED IN DENMARK

Item : FPP60XX02 + 12000
Date : 2016.01.09 IPX6

NOT TO BE OPENED BY UNAUTHORIZED PERSONNEL
NE PAS OUVRIR PAR DU PERSONNEL NON AUTORISÉ

MADE BY LINAK A/S DENMARK

W/O #1234567 - 0001

The FPP is for use with a variety of different bed types and is therefore compatible with control boxes that use an OpenBus™ interface i.e. CB6S, CB16 and CB20.

Usage:

- Ambient temperature: +5° to +40°
- Approvals: LINAK and UL International DEMKO A/S are currently in the process of certifying FPP re. UL60601 and EN60601-1.
- Current consumption: 15 mA (Standard versions with 5 no. LED's (5 LED's x 2 mA = 10 mA) + microprocessor 5 mA, total = 15 mA)



Recommendations

- The application manufacturer must insure a proper installation of the FPP in the application. The installation must be convenient for the end-user.
- To ensure proper activation, the lock above the housing must be properly locked by turning it clockwise.
- The application manufacturer must ensure the correct torque to the slotted set screw at the bracket, to ensure a stable positioning of the FPP.
- The application manufacturer must consider the bracket location for the FPP: If the FPP is mounted at a moveable part, it will move and might touch the patient or parts of the application. If mounted at a fixed part, the patient might move out of range to reach the FPP or he might even be hit by the FPP.
- The end-user must not apply a torque to the FPP housing exceeding 8 Nm between the flexible arm and the panel.
- The end-user must not bend the FPP arm to a radius smaller than 105 mm.
- The FPP must not be used as a handle at any time when moving the application.
- The end-user must be informed that the FPP must not be used for other purposes (e.g. table, handle) than intended, i.e. as a Flexible Patient Panel (FPP).
- The end-user must ensure the FPP does not hit items or persons when the application is moved.

Mounting instructions:

The FPP is intended for mounting at the head end of a bed so the patient is able to see and operate it with an easy push of a button. After use it can be moved a short distance away with an easy movement.

The FPP comes with a cable attached. The bottom part of the arm is prepared for mounting inside a bracket - fitting the diameter of the arm.

The bracket is not supplied by LINAK but must be designed and made by the customer. It must fit the dimensions shown. A suggestion to a design is illustrated on below pictures as well as the dimensions of the parts for fixation.

Dimensions Illustration:

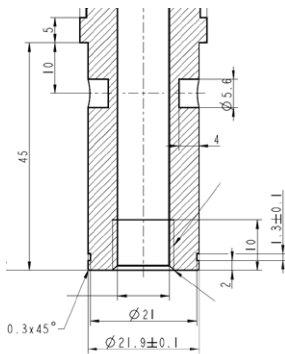

Possible bracket design.

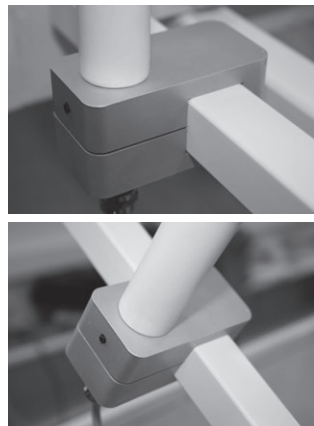

The FPP must be mounted in such a manner that it is secured against rotation. For this purpose the bracket end of the arm has 4 x drilled holes - one of the 4 holes must be secured via the bracket with a slotted set screw with cone point (pointed screw).

Otherwise it may slide away from the user when operated.

As illustrated from the pictures below the panel itself can be moved and angled in a number of positions. The arm can also be bent to move it closer to or move it further away from the user.



The lock function

Between the arm and the panel there is a lock/unlock function, (a hose type connection). It enables the user to turn the panel into a preferred position.

Locking of the Panel:

Turn the panel to a preferred position. With one hand on the panel turn the hose clockwise with the other hand. The Panel is fully locked when the panel cannot be turned.

Unlocking of the Panel:

With one hand on the panel turn the hose counter clockwise with the other hand until the panel can be moved freely.

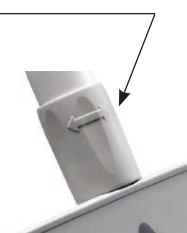

11. FS (MEDLINE® CARELINE® TECHLINE®)



The Foot Switch is a modular system, developed for use together with some of LINAK control boxes. The LINAK Foot Switch is designed for control of physiotherapeutic beds, hospital beds, dentist chairs, gynaecologist chairs, computer workstations, and working desks etc. It can also be used as a "stand alone" item for industrial applications.

Footswitch

Consist of: FS (a pedal unit) and FSE (electronics unit), which can activate one or more actuators. The module system can max. consist of two pedal units, a FSR (right pedal), a FSL (left pedal), and one electronics box.

12. FS2 (MEDLINE® CARELINE®)



The FS2 Foot Switch is developed for use together with some of LINAK control boxes and especially designed for mounting on a support plate.

The Foot Switch is available in a single and a double version.

The double version can be used on a bed where one Foot Switch will be mounted on each side of the bed frame, thus enabling operation from both sides.

13. FS3 (MEDLINE® CARELINE®)

Floor adaptor



Bed adaptor

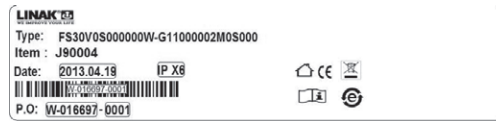

The Foot Switch FS3 is an ergonomically designed modular system, developed for use together with LINAK control boxes and IC actuators with Intelligent Control. The LINAK® Foot Switch is designed for easy and improved control of e.g. hospital beds and couches and has been developed in cooperation with end users. The Foot Switch is therefore very user- and cleaning-friendly and has an aesthetic design.

The FS3 is a robust foot control which is available both as a single and double version as well as a floor and bed model. When mounting the double version on a bed, the Foot Switch will be placed on each side of the bed frame to enable easy operation from both sides. It is also possible to have the double floor version for medical applications, e.g. couches, in order to achieve the opportunity to control different motions of the application. The FS3 is furthermore available in an analogue version and a digital OpenBus™ version.

Usage:

- Usage temperature: + 5° C to + 40° C
- Storage temperature: -10° C to + 50° C
- Relative humidity: 20% to 80% at +30°C
- Atmospheric pressure: 700 to 1060 hPa
- Compatibility: LA27CS, LA43 IC, LA44 IC, analogue control boxes and OpenBus™ control boxes
- Approvals: IEC60601-1:2005 3rd edition, ANSI / AAMI ES60601-1:2005 3rd edition and CAN / CSA-22.2 No 60601-1:2008

Mounting of the FS3 bed model:

To mount the FS3 bed model, you have to use the bolt and the nut which have already been fitted to the FS3 bed model (see picture below).

Bolt and nut for mounting

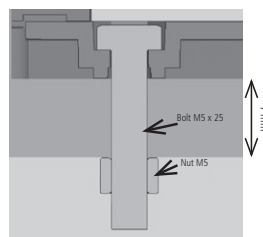
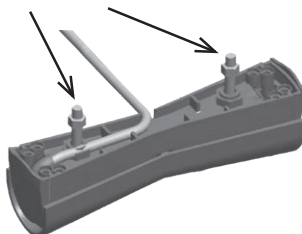

...to be continued