



Linear Actuators and Electronics User manual

Contents

Preface	5
Valid for	6
Important information	7
Lithium ion batteries	10
General assembly instructions	11
Declaration of incorporation of partly completed machinery	12
1. System description	13
Electrostatic discharge (ESD).....	14
Fundamental actuator construction	14
Warranty and service life	14
IP Protection degree	15
IPX6 Washable - Description of washing test	16
Cable Wash	17
Maintenance	18
Environmental conditions	18
Insulation class	19
Key to symbols	19
ETL-marking	20
Mounting	20
Connecting the system	21
JUMBO system (special information)	22
Batteries	24
2. Information on start-up, de-installation and operation	26
Troubleshooting Actuators / Lifting columns	27
Troubleshooting Electronics	27
3. Information on specific actuators	28
LA22	28
LA23 DESKLINE®	28
LA23 MEDLINE® CARELINE® TECHLINE®	29
LA23 IC	34
LA27	38
LA28	39
LA28 Compact	40
LA29	40
LA30	41
LA31	42
LA32	44
LA34	45
LA40 HOMELINE®	47
LA40 MEDLINE® CARELINE®	48
LA43	50
LA43 IC	52
LA44	54
LA44 IC	56
4. Information on specific columns	57
BB3	57
BL1	57
BL4	61
LC2	64
LP2	64
LP3	65

5. Information on specific control boxes	66
General information	66
CA30 / CA40	67
CB6	71
CB6 OBMe	72
CB6P2	73
CB6S	74
CB7	76
CB8A	76
CB8-T	77
CB9 HOMELINE®	77
CB9 MEDLINE® CARELINE®	77
CB9 CARELINE® BASIC	79
CB12	79
CB14	80
CB16	80
CB20	82
CBR1	82
CO41	83
CO61	88
CO71	93
6. Information on specific controls	98
ACC	98
ACK	98
ACL	98
ACM	99
ACO	99
ACOM	99
ACP	100
ACT	100
DPH Medical	102
FPP	103
FS	105
FS2	105
FS3	105
HB20	106
HB30	107
HB40	108
HB50	109
HB60	109
HB70	109
HB80	110
HD80	111
HD80 JUMBO	112
HL70	112
HL80	113
IRO	114
LS	114
LSD	114
7. Information on specific JUMBO	115
BAJ1 / BAJ2	115
BAJL Li-Ion	115
CBJ1 / CBJ2	117
CBJ-Care	119
CBJ-Home	122
COBO	123
COBO20	124
CH01	125
CHJ2	125
MBJ1/2/3	125

8. Information on specific accessories	126
General information	126
BA18	126
BA19 lead acid	126
BA21	128
CCS	129
CS16	132
DJB	132
EBC	132
Massage Motor Medical	133
MJB	133
MJB8	134
Simulator tool	135
SLS	136
SMPS30	136
Under Bed Light 2	138
WET Sheet	138
9. Repair and disposal	139
Main groups of disposal	140
Practical information	143
Drawings	145
Addresses	152

Preface

Dear User,

We are delighted that you have chosen a product from LINAK®.

LINAK systems are high-tech products based on many years of experience in the manufacture and development of actuators, electric control boxes, controls and chargers.

This User Manual does not address the end-user. It is intended as a source of information for the manufacturer of the equipment or system only, and it will tell you how to install, use and maintain your LINAK electronics. It is the responsibility of the manufacturer of the end-use product to provide a User Manual where relevant safety information from this manual is passed on to the end-user.

We are sure that your LINAK system will give you many years of problem-free operation.

Before our products leave the factory they undergo full function and quality testing. Should you nevertheless experience problems with your systems, you are always welcome to contact your local dealer.

LINAK subsidiaries and some distributors situated all over the world have authorised service centres, which are always ready to help you.

LINAK provides a warranty on all its products.

This warranty, however, is subject to correct use in accordance with the specifications, maintenance being done correctly and any repairs being carried out at a service centre, which is authorised to repair LINAK products.

Changes in installation and use of LINAK systems can affect their operation and durability. The products are not to be opened by unauthorised personnel.

The User Manual has been written based on our present technical knowledge. We are constantly working on updating the information and we therefore reserve the right to carry out technical modifications.

LINAK A/S

Valid for

This User Manual is valid for the following products:
(See the first 3 - 5 characters on the label)

Actuators:	LA22, LA23 DESKLINE®, LA23 MEDLINE® CARELINE® TECHLINE®, LA23 IC, LA27, LA28, LA28 Compact, LA29, LA30, LA31, LA32, LA34, LA40 HOMELINE®, LA40 MEDLINE® CARELINE®, LA43, LA43 IC, LA44, LA44 IC
Columns:	BB3, BL1, BL4, LC2, LP2, LP3
Control boxes:	CA30, CA40, CB6, CB6 OBMe, CB6P2, CB6S, CB7, CB8A, CB8-T, CB9 HOMELINE®, CB9 MEDLINE® CARELINE®, CB9 CARELINE® Basic, CB12, CB14, CB16, CB20, CBR1, CO41, CO61, CO71
Controls:	ACC, ACK, ACL, ACM, ACO, ACOM, ACP, ACT, DPH Medical, FPP, FS, FS2, FS3, HB20, HB30, HB40, HB50, HB60, HB70, HB80, HD80, HD80 JUMBO, HL70, HL80, IRO, LS, LSD
JUMBO systems:	BAJ1/2, BAJL Li-ion, CBJ1/2, CBJ-Care, CBJ-Home, COBO, COBO20, CH01, CHJ2, MBJ1/2/3
Accessories:	BA18, BA19 lead acid, BA21, CCS, CS16, DJB, EBC, Massage Motor Medical, MJB, MJB8, Simulator tool, SLS, SMP530, Under Bed Light 2, WET Sheet

Important information

Description of the various signs used in this manual.



Warning

Failure to comply with these instructions may result in accidents involving serious personal injury.



Failing to follow these instructions can result in the product being damaged or destroyed.

Please read the following safety information carefully.

It is important for everyone who is to connect, install or use the systems to have the necessary information and access to this User Manual.

Please be advised that LINAK has taken precautions to ensure the safety of the actuator system. It is the responsibility of the manufacturer/OEM to get the overall approval for the complete application.

LINAK recommends that the actuators should be used in push applications, rather than pull applications.

LINAK actuators are **not** to be used for repeated dynamic push-to-pull movements. This cause extra strain to the actuator and can give safety considerations, the consequence being possible damage to the actuator, e.g.:

- Piston rod eye/back fixture cracks due to fatigue.
- Extra play as parts are deformed.
- Noise as internal parts are moving due to the shifting force direction.

Therefore, if repeated dynamic push-to-pull movements are essential for the application, perform tests to validate the performance.

Moreover, consider strengthening the actuator (e.g. using a steel piston rod eye) – contact LINAK A/S if in doubt.

If the actuator is used for push in an application where personal injury can occur (e.g. patient hoists), a special safety nut must be used.

In general the LA12 actuator is not to be used in push/pull situations.

LINAK® actuators and electronics generally fall outside the IEC 60601-1:2005 definition of applied parts and are not marked as such (IEC 60417-5840).

However assessing the risk, whether actuators and electronics unintentionally can come into contact with the patient, determines that they are subject to the requirements for applied parts. All the relevant requirements and tests of the standard are carried out as part of the IEC CB-Scheme assessment.

RF transmitter properties:

Some LINAK products emit RF-power by intention for the means of communication.

Frequency band of transmission: 2400MHz – 2485MHz.

Type: BLUETOOTH Low Energy BLE 4.2

Modulation: GFSK

Maximum Effective Radiated Power (ERP): 10dBm

Output ratings:

Nominal values:

On the marking plate on LINAK Control Boxes, Battery Boxes and Power Supplies, we may state the nominal output voltage at a certain load for a certain product.

Depending on product and load, this value may vary significantly due to construction.

E.g.: For a product with a nominal output voltage of 24VDC, the expected output voltage may vary depending on product and load within a range from approximately 20VDC to approximately 50VDC due to construction.

When combining LINAK Control Boxes, Battery Boxes and Power Supplies with other LINAK components, compatibility is ensured.

When combining LINAK Control Boxes, Battery Boxes or Power Supplies with third party products, special precautions may be taken.

Relative or absolute positioning for the PLC connection

Relative positioning - By means of a magnetic disc and a hall sensor in the PLC-actuator, it is possible to have encoder pulses with an accuracy down to 0.5 mm per pulse. This signal can be connected directly to the PLC's standard digital input.

Absolute positioning - As an alternative the user can have a 0-10V analogue signal from a potentiometer integrated in the PLC-actuator (max. stroke 100 mm). This signal can be connected directly to an analogue PLC input.

Classification:

The equipment is not suitable for use in the presence of a flammable anesthetic mixture with air or with oxygen or nitrous oxide.



Warning

Electromagnetic compatibility - general

LINAK Actuator Systems bear the CE marking as an attestation of compliance With the EMC Directive 2014/30/EU; the systems are designed to meet all requirements of applicable standards and have been tested to meet requirements of IEC 60601-1-2:2014.

Emission:

LINAK Actuator Systems are CISPR 11, Group 1, Class B products, unless stated otherwise in the relevant section of this document.

Immunity:

Test levels are according to Professional Healthcare Facility Environment.

Electromagnetic phenomena are evaluated on a system level, with the actuator either connected to a LINAK Control Box and accessories or to some customer-built electronic control circuitry.



Warning

Electromagnetic compatibility – third party components

Use of accessories, transducers and cables other than those specified or provided by the manufacturer of the Actuator System could result in increased electromagnetic emissions or decreased electromagnetic immunity of the Actuator System and result in improper operation.



Warning

Electromagnetic compatibility – interference with other equipment, general

Use of the Actuator System adjacent to or stacked with other equipment should be avoided as it could result in improper operation.

If such use is necessary, the Actuator System and the other equipment should be observed to verify that they are operating normally.

If the user notes unusual behavior of the Actuator System, in particular if such behavior is intermittent and associated with the standing right next to mobile phones, microwaves and radio broadcast masts, this could be an indication of electromagnetic interference.

If such behavior occurs, try to move the Actuator System further away from the interfering equipment.



Warning

Electromagnetic compatibility – interference with other equipment, RF communications

Portable RF communications equipment (including peripherals such as antenna cables and external antennas) should be used no closer than 30 cm (12 inches) to any part of the Actuator System, including cables specified by the manufacturer. Otherwise, degradation of the performance of this equipment could result.



Warning

If the actuator or lifting column is used for pull in an application where personal injury can occur, the following is valid:

It is the application manufacturer's responsibility to incorporate a suitable safety arrangement, which will prevent personal injury from occurring, if the actuator should fail.



Residual risk

Some of the products contains software based components. LINAK has done various possible efforts to assure that the software is free of errors and that the software has been developed according to the rules of IEC 60601-1-4 (software in Medical products). That involves risk analysis which shows a small residual risk for unwanted/unintended mow of actuators under specific conditions.

According to the above rules it must be informed and if necessary considered in the risk analysis of the final application - More details to residual risk can be provided by LINAK if necessary.



Warning

Note that during construction of applications, in which the actuator is to be fitted, there must be no possibility of personal injury, for example the squeezing of fingers or arms.



Warning

The plastic parts in the system cannot tolerate cutting oil.



Warning

Assure free space for movement of application in both directions to avoid blockade



Warning

Uninstructed personell must not operate the application or the actuator



Warning

In the event of blockage by an obstacle when application is moving inwards, removing the obstacle will cause the load to drop until spindle hits the nut



Warning

Do not turn outer tube



Warning

Do not use chemicals, and inspect yearly for damage and wear.



Warning

Do not expose LINAK Actuator System Components to high intensity ultraviolet radiation disinfection lamps. This may damage enclosure, supporting parts and cables.



Warnings

LINAK's actuators and electronics are not constructed for use within the following fields:

- Planes and other aircrafts
- Explosive environments
- Nuclear power generation



Warning

LINAK recommends that the actuators should be used in push applications, rather than pull applications.

If the actuator is used for push in an application where personal injury can occur (e.g. patient hoists), a special safety nut must be used. Except for the LA34 which can be used for both push or pull applications, if mounted with safety nuts in both directions.



Warning

- If faults are observed, the products must be replaced.
- Never spray directly on the products with a highpressure cleaner.



Warning

A LINAK control box, actuator and accessory component must, in the final application, be placed where it is not imposed to any impact. This is to prevent damage by accidentally being struck by an object in the hand of a passer-by or by a broomstick or a mop handle during cleaning the floor. On a medical bed e.g. this might be underneath the mattress support platform. If necessary to mitigate this risk, additional protection might be required.



Warning

Do not shorten the battery, other loads than self-discharge flatten the battery and cause formation of lead sulphate, which, if left in this state for too long, will irreversibly damage the battery. Avoid bad impact on individuals and environment.



Warnings

Prevent foreign objects or persons from unintentionally activating a footswitch or a hand control at any time e.g. during normal use or maintenance.

A hand control could be activated by squeezing e.g. between the mattress and the bed frame/rails or when it hangs on an application that is activated by moving another application into it or by moving the application into something else, e.g. a wall, furniture, another application etc.



Warning

Handle batteries carefully.



LINAK battery packs may emit flammable gases. So do not bring fire or a heated object close to the battery pack, and never use the battery near a spark, fuses and/or equipment that emits sparks. Further, do not store the battery in a closed environment or incorporate it into a closed structure of an enclosure. Doing so can cause an explosion, fire, equipment damage and bodily injury.



Do not connect the positive terminal and the negative terminal of the LINAK battery packs with a wire or other metals. Be careful with tools and do not wear jewelry when handling batteries. Short-circuiting the terminals of the battery can cause burn injuries, damage to the storage battery or trigger explosions.



Never connect the LINAK battery packs directly to a power supply socket or an automobile's cigarette lighter without using a charger as a medium. Connecting the battery directly can cause the battery to leak fluid, generate heat, explode, cause fires or bodily burns and injuries.



LINAK battery packs contain toxic substances. If the battery's internal fluid leaks out and gets onto your skin or clothing, make sure it is washed off with clean water. Additionally, if the fluid gets in your eyes, wash them with clean water immediately, and see a doctor. If battery fluid gets into your eyes, it can cause a loss of eyesight and when it gets on your skin, it can cause a burn on your skin.



Do not use or store LINAK battery packs where the surrounding temperature exceed 50°C, such as inside a hot automobile, in direct sunlight, or in front of a stove or a source of intense heat. Doing so can shorten battery life, lower its performance level, cause the battery to leak fluid, explode, cause fire, be damaged or deformed.



Do not use a LINAK cord set for other devices than LINAK control boxes or LINAK power supplies.



For actuators without plugs, which are not connected to a LINAK control box, the mains supply or the actuator must always be equipped with an arrangement that switches off the actuator at the end-stop, for example, LS or LSD limit switch. If there is a risk of overloading the actuator, the mains supply must be equipped with a safety device against overloading (for example a CS16-PCB). If these precautions are not observed, the actuator can be damaged.



The LINAK products cannot tolerate the influence of strong solvents, basic or alkaline liquids.



Non-LINAK handsets

LINAK handsets are designed specially for LINAK control boxes, and they are designed to be highly reliable and flexible. If the customer still wishes to use his own handset, it is important to contact a LINAK sales person to find out the requirements with regard to the switches in the handset. Poor switches can destroy the control box.



The duty cycle printed on the label of the control box must always be noted. If this is exceeded, there is a risk of the control box being overheated and damaged. Unless otherwise specified on the label, the duty cycle is max. 10% : max. 2 min. in use followed by 18 min. not in use.

Lithium ion batteries

Li-ion batteries are moving in the direction of minimising the physical size and at the same time, increasing the capacity. This gives a very size-effective battery but with a high concentration of energy within a small physical size. It also increases the risk of thermal runaway (see note below) due to internal short circuits.

The general use of Li-ion batteries have increased and the inherent risk of thermal runaway has led to stricter rules within the transport industry, specifically air transport with tightened restrictions placed on the quantity transported, handling, and storage of specific products moving via air.

The OEMs and consumers have to recognise that although safe to use, there will always remain a very small risk of thermal runaway on a Li-ion cell. The size of that risk could be as little as 1PPM or even less.

LINAK currently bases our Li-ion battery design on industry proven cell types that have a proven history (e.g. electric cars). The use of well-proven cell technology reduces the risk of thermal runaway, but it does not eliminate it. LINAK has completed activities to reduce this risk and the complete battery package is UL approved.

An external, internationally recognised expert has also reviewed the design to ensure that it is according to latest recommendations. Further to that, we only use cells from well-recognised manufacturers.

LINAK recommends that when using Li-ion batteries, the customer should do a proper risk analysis on their application. The risk analysis must also focus on not mounting these products where they can be in direct contact with flammable materials.

LINAK Li-ion have no more risk of thermal runaway compared to other Li-ion cells from well-recognised manufacturers within the market. Therefore, it is clear that LINAK cannot take responsibility for any failures that occur due to a failure that is inherent in the nature of Li-ion batteries.

If any of the Li-ion batteries built into LINAK products are found to be defective under warranty, LINAK will provide a new product to the OEM. LINAK explicitly disclaims all other remedies. LINAK shall not in any event be liable under any circumstances for any special indirect punitive incidental or consequential damages or losses arising from any incident related to the inherent risk of thermal runaway in the Li-ion cell and any use of LINAK products. Moreover, LINAK explicitly disclaims lost profits, failure to realise expected savings, any claim against our customer by a third party, or any other commercial or economic losses of any kind, even if LINAK has been advised of the possibility of such damages or losses.

Note: *'Thermal runaway' is overheating of a cell and it could lead to a small fire and smoke from the cell.*

Transportation

The lithium ion batteries must be packed and transported according to applicable regulations. Always ask your local transportation provider how to handle the transportation of lithium ion batteries.

Please see the general assembly instructions on page 11 and the mounting section on page 24 for detailed information.

General assembly instructions

Please read the following safety information carefully. Ensure that all staff who are to connect, mount, or use the actuator are in possession of the necessary information and that they have access to this assembly instruction.

Persons who do not have the necessary experience or knowledge of the product/products must not use the product/products. Besides, persons with reduced physical or mental abilities must not use the product/products, unless they are under surveillance or they have been thoroughly instructed in the use of the apparatus by a person who is responsible for the safety of these persons. Moreover, children must be under surveillance to ensure that they do not play with the product.



Warnings

Failure to comply with these instructions may result in accidents involving serious personal injury. It is important for everyone who is to connect, install, or use the systems to have the necessary information and access to the User Manual on www.linak.com.

- If there is visible damage on the product it must not be installed.
- If the control box/TWINDRIVE makes unusual noises or smells, switch off the mains voltage immediately.
- The products must only be used in an environment that corresponds to their IP protection.
- The cleaners and disinfectants must not be highly alkaline or acidic (pH value 6-8).
- Irrespective of the load the duty cycle stated in the data sheets, must NOT be exceeded.
- The DESKLINE® systems can only be used in push applications.
- The control box/TWINDRIVE must only be connected to the voltage stated on the label.
- System not specified for pull must only be used in push applications.
- Fastening screws and bolts must be correct tightened.
- Do not open the closing device on the TWINDRIVE during operation.
- Specifications on the label must under no circumstances be exceeded.
- NOT TO BE OPENED BY UNAUTHORIZED PERSONNEL.
- Do only use the actuator within specified working limits.
- Note that during construction of applications, in which the actuator is to be fitted, there must be no possibility of personal injury, for example the squeezing of fingers or arms.
- If irregularities are observed, the actuator must be replaced.
- If the actuator is used for pull in an application where personal injury can occur, the following is valid: It is the application manufacturer's responsibility to incorporate a suitable safety arrangement, which will prevent personal injury from occurring, if the actuator should fail.
- MEDLINE and CARELINE products are rated to operate at an altitude ≤ 2000 m.



Failing to follow these instructions can result in the actuator suffering damage or being ruined.

- Before you start mounting/dismounting, ensure that the following points are observed:
 - The actuator is not in operation.
 - The mains current supply is switched off and the plug has been pulled out.
 - The actuator is free from loads that could be released during this work.
- Before you put the actuator into operation, check the following:
 - The actuator is correctly mounted as indicated in the relevant user instructions.
 - The equipment can be freely moved over the actuator's whole working area.
 - The actuator is connected to a mains electricity supply/transformer with the correct voltage and which is dimensioned and adapted to the actuator in question.
 - Ensure that the voltage applied matches to the voltage specified on the actuator label.
 - Ensure that the connection bolts can withstand the wear.
 - Ensure that the connection bolts are secured safely.
- During operation
 - Listen for unusual sounds and watch out for uneven running. Stop the actuator immediately if anything unusual is observed.
 - Do not side load the actuator.
 - Use only the actuator within the specified working limits.
 - Do not step or kick on the actuator.
- When the equipment is not in use
 - Switch off the mains supply or pull out the plug in order to prevent unintentional operation.
 - Check regularly the actuator and joints for extraordinary wear.
- Note:
 - If the actuator is operated as a hand crank, it must be operated by hand, otherwise there is a risk of overloading the actuator and hereby damage the actuator.
- Note:
 - When changing the cables on a LINAK actuator, it is important that this is done carefully, in order to protect the plugs and pins. Please be sure that the plug is in the right location and fully pressed in before the cable lid is mounted.

DECLARATION OF INCORPORATION OF PARTLY COMPLETED MACHINERY

LINAK A/S
Smedevænget 8
DK - 6430 Nordborg

Herewith declares that **LINAK DESKLINE®** products as characterised by the following models and types:

Control Boxes	CBD6S
Linear Actuators	DB5, DB6, DB7, DB9, DB12, DB14, DB16, LA23, LA31
Lifting Columns	DL1A, DL2, DL4S, DL5, DL6, DL7, DL8, DL9, DL10, DL11, DL12, DL14, DL15, DL16, DL17, DL19, BASE1
Desk Panels	DPA, DPB, DPH, DPF, DPG1K, DPG1M, DPG1B, DPG1C, DPT, DP1, DP1CS, DP1K, DP1V, DP1U
RF Controls	HB10RF, HB20RF, RFT, RFRL
Accessories	BA001, SLS, Kick & Click

Herewith declares that **LINAK HOMELINE®** products as characterised by the following models and types:

Control Boxes	CB9H, CBH Advanced, CBH Basic
Linear Actuators	LA27, LA28, LA29, LA31 HOMELINE, LA40 HOMELINE
Dual Actuators	TD3, TD4
Controls	HB10, HB10 Wireless, HB20, HB40, HB60, HC05 Wireless, HC10, HC10 Wireless, HC20 Wireless, HC30 Wireless
Accessories	Bluetooth® Adapter, DC CONNECTOR, LED Lightbox, LED Light Rail, Lightplug001, Massage Motor, SMPS001, SMPS002, SMPS006

Herewith declares that **LINAK MEDLINE® & CARELINE®** products as characterised by the following models and types:

Control Boxes	CA30, CA40, CB6, CB6S, CB6OBMe, CB6P2, CB8, CB9, CB12, CB14, CB16, CB20, CBJ, CBJ-Care, CBJ-Home, CO61
Linear Actuators	LA12, LA22, LA23, LA27, LA28, LA29, LA30, LA31 CARELINE, LA32, LA34, LA40, LA43, LA43IC, LA44, LA44IC
Lifting Columns	BL1, LP2, LP3, LC2
Controls	ACC, ACK, ACO, ACL, ACM, ACP, ACT, DP, DPH, FS, FS3, FPP, HB20, HB30, HB40, HB50, HB70, HB80, HD80, HL70, HL80, IRO
Accessories	BA18, BA19, BA21, BAJ, BAJL, CH01, CHJ2, COBO, DJB, EBC, IRO, MJB, SMPS19, SMPS30, Scale, SCO SLS, Massage Motor, UBL22

Herewith declares that **LINAK TECHLINE®** products as characterised by the following models and types:

Linear Actuators	LA12, LA14, LA22, LA23, LA25, LA30, LA33, LA35, LA36, LA37
Power Supply	SMPS-T160

comply with the following parts of the Machinery Directive 2006/42/EC, ANNEX I, Essential health and safety requirements relating to the design and construction of machinery:

1.5.1 Electricity supply

The relevant technical documentation is compiled in accordance with part B of Annex VII and that this documentation or part hereof will be transmitted by post or electronically to a reasoned request by the national authorities.

This partly completed machinery must not be put into service until the final machinery into which it is to be incorporated has been declared in conformity with the provisions of the Machinery Directive 2006/42/EC where appropriate.

Nordborg, 2017-12-08



LINAK A/S
John Kling, B.Sc.E.E.
Certification and Regulatory Affairs
Authorized to compile the relevant technical documentation

1. System description:

Usage/type of applications:

LINAK actuators, lifting columns and electronics have been developed for use in all places where a linear movement is required.

LINAK's products can, for example, be used for:

- Adjustment of beds
- Adjustment of furniture
- Adjustment of table heights and angles
- Patient hoists within the care and hospital sector
- Adjustment of industrial processing machines
- Adjustment of agricultural machines
- Adjustment of ventilation systems
- Adjustment of dentist chairs/gynaecological chairs
- Etc.

The principles of a LINAK system are as follows:

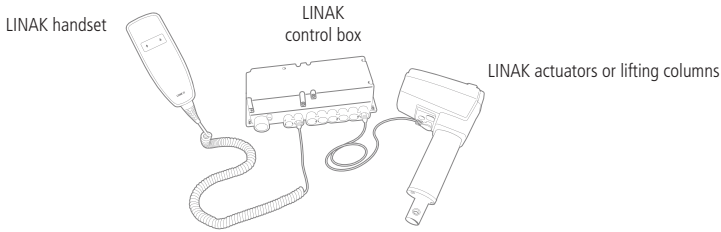

Attention should be paid to the following:

- Control boxes must only be connected to the mains voltage specified on the label. All DIN, jack, or minifit plugs from the CB6S/CB12/CB14/CB16/CB20 IPX6 Washable should be locked by using a LINAK locking mechanism.
- The control box must be connected in such a way that the cables are not trapped, exposed to tension or sharp objects when the application is moved in different directions.
- All Control boxes with mains supply should be connected to the mains before they are able to work.
- On an Openbus system the maximum power consumption is max 200 mA on 8V and on 40 V lines for all connected units.
- On an Openbus system the maximum connected number of unit are 12 version 1.0" and for version 1.1 the max numbers are 20.

Prior to first use of LINAK batteries, please make sure that they are being charged 24 hours in order to reach proper function and prolong the lifetime of the batteries.

If the customer uses a non-LINAK battery, it is important to check that the current is not reversed (plus and minus swapped over) This applies to both control boxes, which always run off battery and control boxes with battery backup. Contact your nearest LINAK dealer for specification of type, size etc.

The control current in the handset cable must not exceed 100 mA.

The control box is the heart of the system and connects the various outlying units (actuators, lifting columns, handsets and attendant controls). Control boxes differ widely in complexity. The simplest are only able to convert control signals from the handset into operating voltage for the actuator. The most advanced are microprocessor controlled and have advanced functions such as, parallel running of several actuators and other complex correlations. Most LINAK control boxes provide an Electronic Overload Protection (EOP), designed to protect the actuator (excl. LA12, LA29, LA31, LA34), against overload by disconnecting the current when the actuator is fully extended or retracted. If an LA12, LA29, LA31, LA34 actuator is used, the built-in limit switches stop the actuator when fully extended or retracted, and the control box only disconnects when the maximum current is exceeded. Please contact LINAK for further details on specific systems.

The actuator is the unit, which converts the operating voltage from the control box into a linear movement.

The principle of the LINAK actuator's mode of operation is that a low voltage DC motor (5), via a gear system (12), rotates a threaded spindle, onto which a nut is fitted. As this nut cannot rotate, since the piston rod (2) is restrained, the piston rod will move forwards or backwards, when the threaded spindle rotates.

On the basis of motor type, gearing, and the threaded spindle's pitch, the actuator's thrust and speed are determined.

The handset is the unit to be used when you want the LINAK® system to perform a movement. It determines whether the control box will make the actuator move in or out. There are many variants of LINAK handsets.

The Attendant Control (ACC, ACK, ACL, ACM, ACP, ACO) is an accessory used when nursing staff want to restrict the patients adjustment options of a bed. It is often used in conjunction with a handset and disables selected functions on the handset. It can also have control functions with the same function as those on the handset.

For safety reasons, open function activation of ACP and ACO (ACC, ACK) requires activation of two buttons.



Recommendation

It is recommended to have options like quick release, manual lowering or similar built into the system, in case of power loss or system failure, if movement of the system is critical. After service it is recommended to test the system for correct functionality before it is put back into operation.

Electrostatic discharge (ESD)

LINAK considers ESD to be an important issue and years of experience have shown that equipment designed to meet the 8kV level specified in the Standards such as IEC 60601-1-2, EN50082-2 are insufficient to protect electronic equipment in certain environments.

LINAK handles all Electro Static Discharge Sensitive devices (ESDS) according to EN61340

1. Handling and Mounting of ESDS devices.

- Handling of sensitive components only takes place in an ESD Protected Area (EPA) under protected and controlled conditions.
- Wrist straps and/or conductive footwear (personal grounding) are always used when handling ESDS devices.
- Sensitive devices are protected outside the EPA by the use of ESD protective packaging.

2. Responsibility LINAK/Customer.

- ESDS devices must under no circumstances, during transport, storage, handling, production or mounting in an application, be exposed to harmful ESD.
- LINAK can only guarantee the lifetime of ESDS devices if they are handled in the same way from production at LINAK A/S until they are mounted in the manufacturers application. It is therefore important that the ESDS devices are not removed from the ESD protected packaging before they are within the EPA area at the customers premises.

Please refer to EN61340 for further information:

EN61340-5-1, Electrostatics - Protection of electronic devices from electrostatic phenomena - General requirements

EN61340-5-2, Electrostatics - Protection of electronic devices from electrostatic phenomena - User guide

Fundamental actuator construction

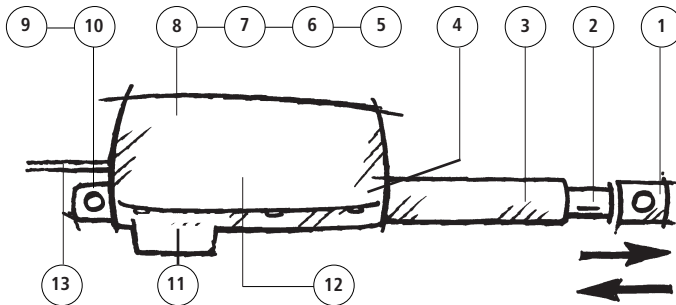

1. Piston rod eye

2. Piston rod

3. Location of mechanical splines

4. Location of brake

5. Motor

6. Motor with optical switch

7. Motor with potentiometer

8. Motor with reed-switch

9. Back fixture

10. Back fixture with electrical splines

11. Quick release mechanism

12. Transmission between motor and spindle

13. Cable for connection to 12/24/36V DC by means of plug via control box

Warranty and service life

The LINAK® warranty covers manufacturing defects in the products, starting from the date of manufacture. There is 36 months' warranty on the HOMELINE® products, 60 months' for MEDLINE® and CARELINE® products, and 18 months' for the TECHLINE® products. There is 12 months' warranty on batteries. The warranty is limited to the value of the LINAK product.

LINAK's guarantee is only valid so far as the products have been used and maintained correctly and has not been tampered with. Furthermore, the products must not be exposed to violent treatment. In the event of this, the warranty will be ineffective / invalid. LINAK's warranty is only valid if the system is unopened and has been used correctly.

All LINAK products are designed to have an optimum service life as a matter of course, but the expected service life in a specific application is very dependent on how the products are used.

IP Protection degree

The products can be cleaned as follows according to their IP protection, which is stated on the product label.

The IP code specifies the degrees of protection provided by the enclosures. For most products only the protection against ingress of water (second characteristic numeral) is specified, ingress of solid foreign objects or dust (first characteristic numeral) is not specified and therefore replaced by the letter X in the code. For some special industrial products both the first and second characteristic numerals are specified. This is a demand from the marked and will only be specified if tested and approved.

IP protection	Cleaning instructions
IPX0	Clean with a damp cloth
IPX1	Clean with a damp cloth
IPX2	Clean with a damp cloth
IPX3	Clean with a damp cloth
IPX4	Clean with a damp cloth
IPX5	Wash with a brush and water, but not water under pressure
IPX6	Wash with a brush and water. The water can be under pressure, but the system must not be hosed down directly with a highpressure cleaner. Max. 20°C
IPX6 Washable according to IEC 60601-2-52	Clean by the use of wash tunnels according to IEC 60601-2-52

To avoid degreasing of the piston rod, the actuator should be retracted to minimum stroke and without load before washing.



Warning

The systems must not be sprayed directly with a highpressure cleaner.



Warning

Interconnecting cables must remain plugged in during cleaning to prevent the ingress of water.



Warning

Cleaning with a steam cleaner is not permitted.

IPX6 Washable - Description of washing test

LINAK washable products are frequently put through a fully regulated washing test.

LINAK understanding of the word washable is that the products conform to this test and none other.

Reference: The Norm EN 60601-2-52, which includes special demands to fundamental safety and relevant functional characteristics for hospital beds.
The demands for the washing process are described in the German "*Maschinelle Dekontamination*" from the organization AK-BWA.

Description: At LINAK the washing test takes place in an instrument washing machine, which is fitted and programmed in such a way that it duplicates the process used in a typical hospital installation for the cleaning of beds and other medical equipment.
During the test the products are exposed to both thermal and chemical effects.
To avoid degreasing of the piston rod, the actuator should be retracted to minimum stroke and without load before washing.

Preparation: As plastic materials to a larger or lesser degree change characteristics and shape with time and climatical exposure, an aging of the products is carried out first. The conditions for aging are 65 °C +/- 2°C in normal dry air for 10 days followed by a minimum of 16 hours at room temperature before the washing process starts.

Procedure: Aging for 10 days at 65°C.
Rest for a minimum of 16 hours.
The washing process proceeds in the following way:

- Wash with Alkaline detergent for 2 min. with 70 °C warm water in the tank
- Rinse with neutral rinsing product for 20 sec. with 85 °C warm water in the tank
- Drying and cooling for 10 min. in open air at normal room temperature approx. 20 °C
- The washing process is repeated 50 times

Washing machine: Only flat squirt nozzles are allowed. An approved setup could be:
Water Pressure 3 Bar, water volume 5,61 L/min, Dispersion angle 120 degree, flat squirt nozzle.

Washable products and mounting: The products used in washable applications should be specified as such in the specification phase. The washable components must be mounted according to this guideline to guarantee washability:

The components should be mounted with the plug inserts facing downwards, or situated so that they are protected from direct impact from the water nozzles. The cables should be guided in such a manner, that there is no apparent strain to the interface between the cable and its connection (for instance between cable and control box).

It is furthermore also recommended that the control box is situated as far away from the water nozzles as possible. For instance in the center of the bed frame. Industrial high pressure cleaning is NOT allowed.

It is the application manufacture's responsibility to ensure washability of the application. LINAK can be contacted for technical support if needed.

Water: Degree of hardness not more than 5° dH and no demineralized water.

Detergents: LINAK recommend the following products:

- Sekumatic FDR or FRE from Ecolab
- Neodisher Dekonta from Dr. Weigert
- Thermosept NDR from Schülke or similar with a pH-value of 5-8 and in a concentration of 0.5%

Rinsing aids: LINAK recommend the following products:

- Sekumatic FKN from Ecolab
- Neodisher BP or TN from Dr. Weigert
- Thermosept BSK from Schülke or similar with a pH-value of 5-8 and in a concentration of 0.2%.

Demands to products:

- They must not contain caustic solutions
- They must not change the surface structure or adhesive properties of the plastic
- Must not break down grease.

LINAK washing profile according to EN60601-2-52

LINAK washing machine

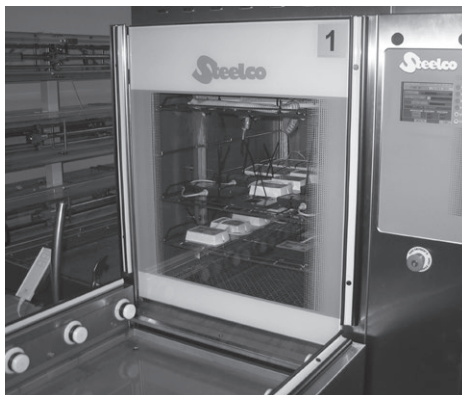
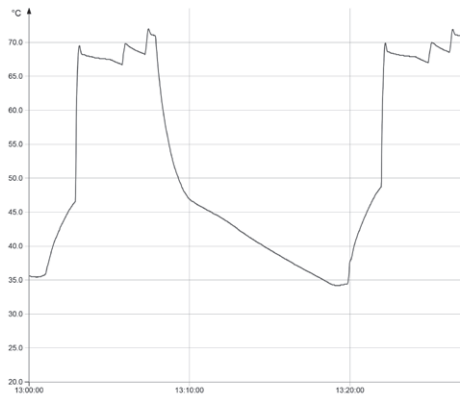

Cable Wash

Before the washing procedure starts!

In order to maintain the flexibility of the cables, it is important that the cable is placed in such a way that the cable's own weight does not strain the coil during the washing process.

This can be done by placing the cable ON the bed or another form of support for the cable.

Please see the examples in the below pictures

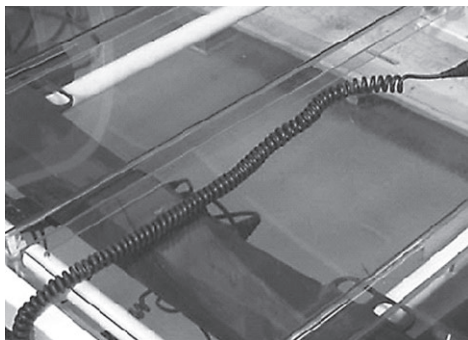

Maintenance

Valid for all LINAK products

- The LINAK products must be cleaned at regular intervals to remove dust and dirt and inspected for mechanical damage, wear and breaks, - worn out parts must be replaced.
- Inspection/maintenance intervals shall be defined by the equipment manufacturer
- The LINAK products are closed units and require no internal maintenance.
- Only type IPX6 is waterproof and type IPX6 Washable tolerates being washed in tunnels.
- The LINAK products must be IPX6 Washable when cleaning in wash tunnels. Make sure that the plugs are correctly fitted with O-rings before washing.
- **O-rings:** When individual parts are replaced in a LINAK IPX6 or IPX6 Washable system, the O-rings on all parts, must be replaced at the same time. On control boxes with a replaceable mains fuse, the O-ring in the fuse cover must be replaced every time the cover has been removed. The O-rings must be greased in water free vaseline when replacing them. Make sure that the counterpart - the socket - is clean and undamaged.

Valid for all LINAK actuators and lifting columns

- Actuators/lifting columns must be inspected at attachment points, wires, piston rod, cabinet, and plugs, as well as checking that the actuator/lifting columns function correctly.
- To ensure that the pregreased inner tube remain lubricated the actuator must only be washed down when the piston rod is fully retracted.

Valid for all LINAK control boxes and handsets

- Electronics must be inspected at attachment points, wires, cabinet, and plugs.
- Inspect the connections, cables, cabinet, and plugs, and check for correct functioning (does not apply to battery versions).
- With the exception of the CS16 the control box is sealed and maintenance free.
- Inspect at regular intervals that the ventilation aperture on the external battery is positioned correctly and is intact throughout its length, approx. 20 mm., **see figure 1.**

Environmental conditions

Storage and transport	
Operating	
Temperature Relative humidity Atmospheric pressure	5°C to 40°C 20% to 90% @ 30°C – not condensing 800 to 1060 hPa (Rated to operate at an altitude ≤ 2000 m)
Storage	
Temperature Relative humidity Atmospheric pressure	-10°C to +50°C 20% to 90% @ 30°C – not condensing 800 to 1060 hPa (Rated to operate at an altitude ≤ 2000 m)
Transport	
Temperature Relative humidity Atmospheric pressure	-10°C to +50°C 20% to 90% @ 30°C – not condensing 800 to 1060 hPa (Rated to operate at an altitude ≤ 2000 m)
<p>If the actuator is assembled in the application and is exposed to push or pull during transportation, the actuator can be damaged.</p> <p>Do not drop an actuator or otherwise damage the housing during disassembly or transportation.</p> <p>We do not recommend using an actuator which has been damaged.</p>	

Valid where nothing otherwise is stated under the specific products in a later section.

Insulation class

LINAK control boxes are available in insulation class 1 and insulation class 2.

Class 1 means with earth connection

Class 2 means without earth connection

When measuring the resistance in the earth connection in LINAK Control Boxes (class 1), it is recommended to use equipment, delivering a test current of no less than 5A. The resulting voltage will correspond to the resistance in the earth connection. Test currents below 5A, would yield no exact measurements.



If the application is insulation dielectric strength tested by applying a test voltage from the terminals of the mains connection to any accessible metal parts (e.g. 4 kV for 240 V rated medical equipment), corona discharge or a momentary flashover might occur within the actuator. This is not considered as an insulation breakdown.

However to avoid to overstress different types and levels of insulation, the control box and the actuator must be tested individually (disconnected) with the respective dielectric strength test voltages (e.g. 4 kV for a 240 V rated control box and 500 V for the actuator). This principle is in accordance with IEC 60601-1:2005, cl. 8.8.3.

Key to symbols

The following symbols are used on the label on the LINAK products.

	IEC 60417-5172: Class II equipment		Recycle		China Pollution control mark (also indicates recyclability)
	Product with a thermofuse		UL Listing Mark		ZERO standby power
	IEC 60417-5957: For indoor use only		UL Listing Mark for Canada		Regulatory Compliance Mark: The Australian Safety/EMC Regulations
	IEC 60417-5222: Safety isolating transformer, general		UL Listing Mark for Canada and the United States		Protection against contact/ foreign matter (first character) and water (second character) as per EN60529
	IEC 60417-5840: Patient part of type B		UL Listing Mark		Alternating Current
	Patient part of type BF		UL Listing Mark		Direct current
	Earth		AS 3108 Australian approval mark		Lock function
	IEC 60417-5019: Protective earth; protective ground		Various		Release function
	IEC 60417-5002: Positioning of cell		TÜV Rheinland - LGA tested		Charge indicator
	ISO 7000-0434A: Caution, consult accompanying document		Recognised Component Mark		Safety switch/enable button
	ISO 7000-1641 Operating instructions		Canadian Recognised - Component Mark		Reduced ETL Recognized Component mark for Canada and United States.
	Electronics scrap		Recognised Component Mark for Canada and the United States		X: The mark is always accompanied by a Control Number of 6 or 7 figures.
	Electronics scrap		PSE-Mark		For complete description, see ETL-marking on next page.
			Compliance to all relevant EC directives		

ETL-marking

Due to space limitations, the complete ETL-marking demands are not represented on the marking plates.

The full ETL Recognized Component markings are shown here.



C/N 120690
Conforms to ANSI/AAMI Std. E560601-1
Cert. to CSA Std. C22.2 No. 60601-1



C/N 4008004
Conforms to ANSI/AAMI Std. E560601-1
Cert. to CSA Std. C22.2 No. 60601-1



C/N 4008838
Conforms to ANSI/AAMI Std. E560601-1
Cert. to CSA Std. C22.2 No. 60601-1



C/N 9901916
Conforms to ANSI/AAMI Std. E560601-1
Cert. to CSA Std. C22.2 No. 60601-1



C/N 4008005
Conforms to ANSI/AAMI Std. E560601-1
Cert. to CSA Std. C22.2 No. 60601-1



C/N 4008671
Conforms to ANSI/AAMI Std. E560601-1
Cert. to CSA Std. C22.2 No. 60601-1



C/N 4008003
Conforms to ANSI/AAMI Std. E560601-1
Cert. to CSA Std. C22.2 No. 60601-1



C/N 4008623
Conforms to ANSI/AAMI Std. E560601-1
Cert. to CSA Std. C22.2 No. 60601-1



C/N 4009507
Conforms to ANSI/AAMI Std. E560601-1
Cert. to CSA Std. C22.2 No. 60601-1

Mounting

Actuator:

Do not use any other screws for the mounting brackets than those recommended by LINAK. If longer screws are used they will come into contact with the inner parts of the actuator. This will result in an irregular operation or even damage the actuator.

During mounting, the actuator must always be:

- Fixed, to protect it against torque and bending. **See Figure 2.**
- Fixed, so that it is restrained, but free to move on its mountings. **See Figure 3.**
- Fixed in brackets, which can take up the torque reaction. **See Figure 3.**
- Mounted at right angles, so that the right angle requirement is observed. **See Figure 4.**
- Mounted with correct bolt dimension.
- Mounted with bolts and nuts made of high quality steel grade (e.g. 10.8). No thread on bolt inside back fixture or piston rod eye.
- Bolts and nuts must be protected from being able to fall out.
- Inspect the actuator for damage before mounting. Damaged actuator must not be mounted. Watch e.g. for damaged packaging.
- Do not use a too high torque when mounting the bolts for back fixture or piston rod eye

Control boxes:

- The mounting screws on the control box must be tightened with a maximum torque of 1 Nm
- The mounting surface to which the control box is attached should have a surface evenness better than ± 0.5 mm.
- Systems must not be installed/deinstalled while in operation.
- Control boxes with a wet alarm must be mounted as shown on figure 5.
- Nuts and bolts must be made of steel.
- Nuts and bolts must be tightened securely.
- Control boxes with earth connection (Class 1), here the nut must be tightened with a torque of 1-1,2 Nm.

The correct bolt size for securing the CB8, CB12, CB14, CB16, CB20 and CUDM, is $\varnothing 5$ mm and the ACP box is M5.



Cables:

It is important to remove the transport plastic bag before using the cable. Cables need to be fixed to the application or to be placed in such a way that users cannot stumble and injure themselves.

Accessories:

The mounting screws on the accessories must be tightened with a maximum torque of 1 Nm. IRO can be mounted with a higher torque, up to 2 Nm.

- The mounting surface to which the accessory is attached should have a surface evenness better than ± 0.5 mm.
- Systems must not be installed/de-installed while in operation.
- Nuts and bolts must be made of steel.
- Nuts and bolts must be tightened securely. The correct bolt size for securing the DJB, IRO, MJB, SLS and SMPS30 is M4 and the BA18 is M5.
- Mounting 0964135-C (UBL) must be with M3 bolt and a maximum torque of 0,25 Nm.

Controls:

The mounting screws on the controls must be tightened with a maximum torque of 1 Nm.

- The mounting surface to which the accessory is attached should have a surface evenness better than ± 0.5 mm.
- Systems must not be installed/de-installed while in operation.
- Nuts and bolts must be made of steel.
- Nuts and bolts must be tightened securely.

The correct bolt size for securing the ACC and ACL is M4, for ACP is it M5 and for the ACM is it M6.

For further instructions regarding mounting, see the data sheet for the individual product or in chapter 5, 6 or 8 in this manual.

Connecting the system

Do not connect the mains cable until all actuators and handsets have been connected to the control box.

Start by connecting the handset to the control box. The connection in the control box is marked with "HB".

Connect the different actuators to the different channels on the control box. Each channel is marked with a number (e.g. "1", "2", "3".....).

Check that all plugs are well connected and firm pushed into the connection plug. Due to the fact that LINAK control boxes are designed for a high IP degree a firm force can be required.

Connect the mains cable.

The actuators can now be operated by pushing a button on the handset. Use only one button at the time.

If the control box is equipped with a special software an initializing process might be necessary. This process is described in the software specification.

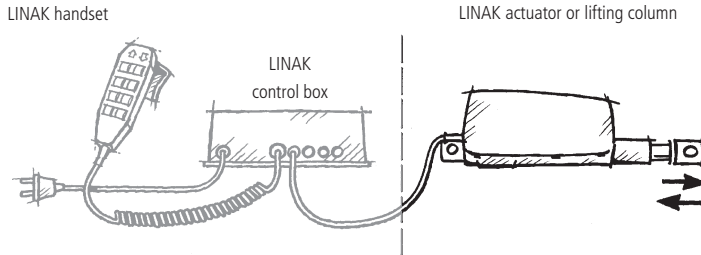

Attention should be paid to the following:

- Control boxes must only be connected to the mains voltage specified on the label. All DIN, jack or minifit plugs from the CB6S/CB12/CB14/CB16/CB20 IPX6 Washable should be locked by using a LINAK locking mechanism.
- The control box must be connected in such a way that the cables are not trapped, exposed to tension or sharp objects when the application is moved in different directions.
- All Control boxes with mains supply should be connected to the mains before they are able to work.

Prior to first use of LINAK batteries, please make sure that they are being charged 24 hours in order to reach proper function and prolong the lifetime of the batteries.

If the customer uses a non-LINAK battery, it is important to check that the current is not reversed (plus and minus swapped over) This applies to both control boxes, which always run off battery and control boxes with battery backup. Contact your nearest LINAK dealer for specification of type, size etc. The control current in the handset cable must not exceed 100 mA.

Any non-detachable power supply cord with mains plug is considered as the disconnecting device.

Charging is only allowed in dry environment, and appliance inlet must be thoroughly dried before connecting to mains.

All types of actuators may only be connected according to the label, where the voltages 12, 24, or 36 VDC are indicated.

- a) Actuators with jack plugs may only be connected to LINAK control boxes
- b) Actuators without plugs are connected as shown in **Figures 6.1 - 6.12**.

For actuators operating without a control box, the mains supply of the actuator must be equipped with an arrangement, which switches off the actuator at end-stop (e.g. LS or LSD limit switch). If there is a risk of overloading the actuator, the mains supply must be equipped with a safety device against overloading (e.g. a CS16 PCB). If this requirement is not observed, the actuator may be damaged.

Actuators with internal control PCBs are not first failure safe if used in a system combination without power request (power for actuator switched ON only when handset key active).

JUMBO™ system (special information)

The LINAK JUMBO system is specially developed for patient lifts, offering various combinations of actuators and control boxes.

Connecting the system:

Mount the mounting bracket (MBJ) to the application. Mount control box and battery (and charger (CHJ2) if equipped).

If it is a JUMBO Home system mount the control box on the application (no mounting bracket is needed).

Only vertical mounting allowed (connectors facing downwards).

Connect the handset to the control box. The connection in the control box is marked with "HB".

Connect the actuators to the control box. Each channel is marked with a number (e.g. "1", "2"). Channel "1" has always to be used for the High / Low (Lifting) function.

The actuators can now be operated by pushing a button on the handset. Use only one button at the time.

Example of JUMBO patient lift system

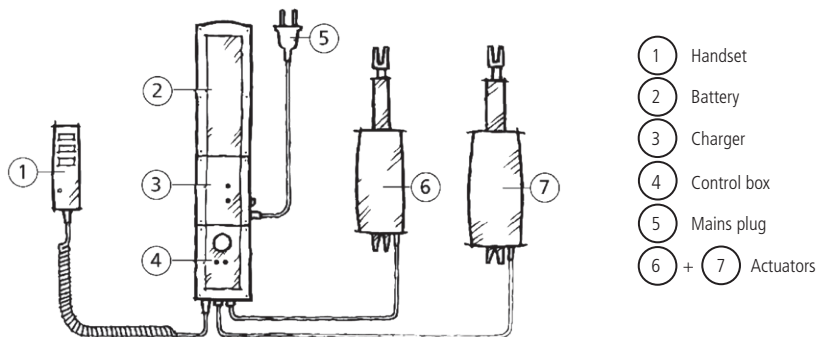

System components:

Actuators	types LA28, LA32, LA34, LA44
Control Box	types CBJ1/CBJ2, CBJC
Batteries	types BAJ1, BAJ2, BAJL
Handsets	types HB5, HB7, HB8
Battery Charger	type CH01

Configuration of the JUMBO System

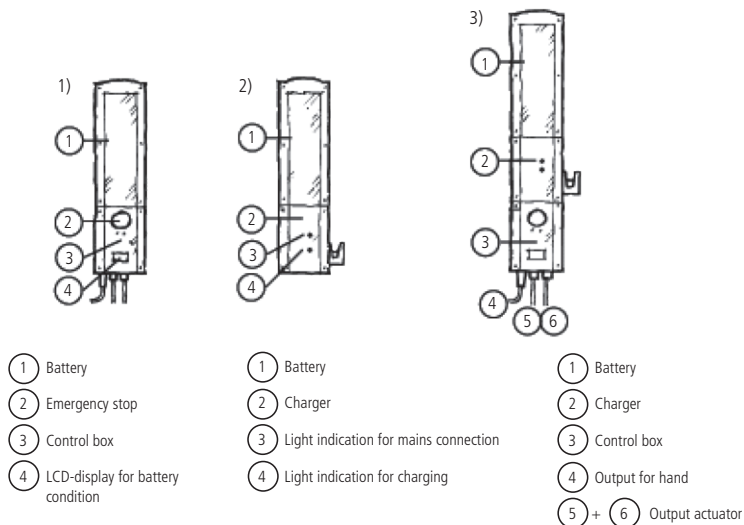

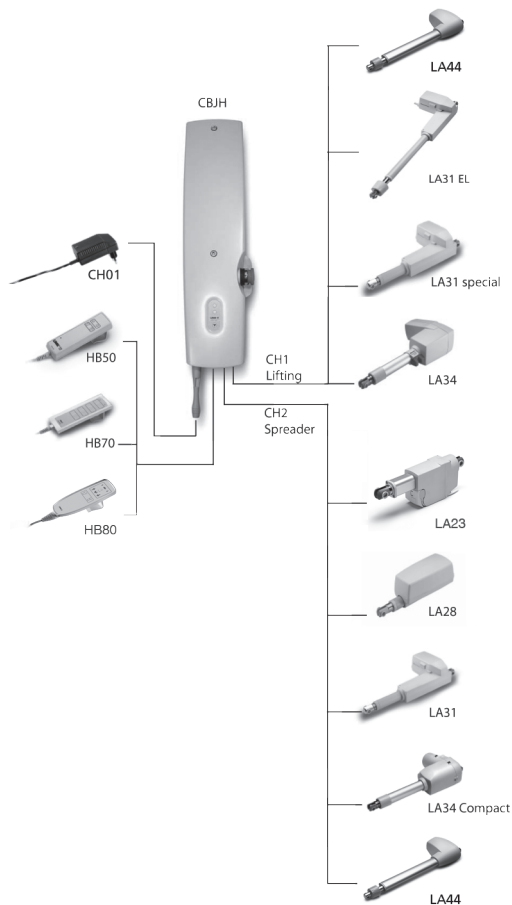

Batteries

Lithium ion batteries



Warnings

- When using BAJL and JUMBO control boxes, loss of power might happen due to the battery deep discharge protection. This will only happen in case of continuous battery use despite warnings. In this event, there may be no warning and the application may not be able to move when expected.
- In his risk analysis, the customer must take into consideration how to assure alternative means to make movement, e.g. quick release or manual lowering.
- The combination of CBJ1 or CBJ2 with BAJL might not be able to complete a full cycle after low battery warning.
- Do not open the battery housing as damaging the cell or circuitry may develop excessive heat.
- If product caution is not clearly visible at low light intensity, read the product label instructions symbol. A warning must be included in the application manufacturer's manual for the medical device.
- The application manufacturer must test the application and ensure that intentional and unintended operations do not exceed the battery specification limits. The application manufacturer must assure other means of movement, e.g. quick release or manual lowering.
- Defective or damaged li-ion batteries are not allowed for transportation.
- For safety reasons, please adhere to the indicated charging and operation temperature.
- In case the battery is too hot, disconnect it and evacuate the room and wait for 2 hours before taking further steps.
- Mounting instructions must be followed in order to avoid exposing batteries to water.
- Recharging of battery must take place every 6 months.
- Disposal of the battery takes place in accordance with local regulations.



Recommendations:

- Do not exceed the storage temperature as it will shorten the product life and performance.
- Allow the battery to settle to room temperature before use.
- Do not exceed the duty cycle (see product label) as it will shorten the product life, reduce performance and eventually activate excess temperature protection.
- Lithium ion batteries are not intended for use in outdoor applications and indoor pool environments.
- If the battery is completely discharged, then recharge the battery before storage.
- Always use correct LINAK charger.



DO NOT:

- Heat or burn the batteries.
- Short circuit the batteries.
- Expose the batteries to high impact / excessive force.
- Crush or puncture the batteries.
- Use batteries with signs of damage or corrosion.
- Charge or store the batteries near combustible material.
- Expose the batteries to water or other liquids.
- Overcharge or fully discharge the batteries.

For detailed information on specific use of batteries, please see the product information in chapter 5.

Safety feature

Lithium ion batteries contain several mechanisms to protect itself from being damaged due to excessive use.

In case of overheating, the device will activate a thermal protection. No power output will be available until the temperature is back again within normal operating range.

Overheating may occur by extensive use at high temperature or when exceeding the duty cycle. (see product label)

Lead acid batteries

Maintenance of batteries

Prior to first use of LINAK batteries, please make sure that they are being charged at least 24 hours and longer if possible in order to reach proper function and prolong the lifetime of the batteries.



Warnings

- Please observe the following maintenance, replacement, and disposal requirements to ensure a safe and reliable operation.
- The batteries are to be replaced after 4 years at the latest. Perhaps earlier, dependent on the pattern of use. Frequent and high-powered discharges reduce the battery life. For an optimum lifetime the product must be connected to the mains voltage as often as possible. It is recommended that the batteries are to be charged at least every 6 months - otherwise will the batteries have reduced capacity due to self-discharge. It is recommended to test the battery function at least once every year.

Replacement of batteries

The batteries must only be replaced by the same type of batteries or mechanical and electrical equivalent types. The batteries must be new or maintained by means of charging at least every 6 months. The batteries, which make a set, must be supplied with identical production codes. Mismatching of production codes may lead to a severely reduced lifetime expectancy.

Before mounting ensure that the battery set is correctly connected, compare with the drawing in the battery room, and check that no connectors are loose.



Warnings

- From the factory, the battery room is hermetically separated from the electronics room. When replacing the batteries this separation must not be damaged or modified as this may allow penetration of battery gas into the electronics room with risk of explosion.
- When replacing batteries in waterproof products (IPX5 and IPX6) precautions must be taken that the sealing material (silicone ring or joint filler) is not damaged and that it is correctly placed in the groove. Hereafter the screws in the cover are to be fastened with approx. 1 Nm. If the seal is damaged it must be replaced by a new silicone string (LINAK article no. 0008004 for a roll of 100 meters).

Disposal

The batteries, which are lead-acid batteries, can be returned to LINAK or disposed in the same way as car batteries.



Warnings

- The battery room is supplied with ventilation that ensures correct and necessary airing of the battery room. This airing must not be blocked or covered as a positive pressure may occur with risk of explosion.
- If the product has been exposed to mechanical overload (lost on the floor, collision/squeezing in the application or a powerful stroke) the product must be sent to an authorised workshop for control of the hermetic separation between the battery and electronics rooms.

2. Information on start-up, de-installation and operation

Before installation, de-installation, or troubleshooting:

- Stop the actuator/lifting column.
 - Switch off the power supply or pull out the mains plug and pull out the plug to the actuator/lifting column.
 - Relieve the actuator/lifting column of any loads, which may be released during the work.
- Prior to first use of LINAK batteries, please make sure that they are being charged 24 hours in order to reach proper function and prolong the lifetime of the batteries.

Before start-up:

- Make sure that the system has been installed as instructed in the User Manual.
- The individual parts (actuator/lifting column/handsets etc.) must be connected before the control box is connected to the mains.
- Make sure that the voltage of the mains to be connected to the product or the system is the one stated on the label.
- Make sure that the actuator/lifting column is connected to a mains electricity supply/transformer with the correct voltage and which is dimensioned and adapted for the actuator in question.
- The equipment can be freely moved over the actuator/lifting column's whole working area.
- Check correct function after mounting.
- The actuator/lifting column must not be loaded in excess of the values indicated in the specifications on the product label.
- The duty cycle noted on the product label must always be noted. Otherwise there is a risk of damaging the products.
Exceeding the duty cycle will result in a dramatic reduction of the life time of the system.
Unless specified otherwise on the product label the duty cycle is max. 10% : Max. 2 minutes in use followed by 18 minutes not in use.
- The actuator/lifting column system may only be used in an environment corresponding to the system's IP-rating.
LINAK products are marked with the actual IP-rating on the label.
- If any individual parts are suspected to be damages, do not install the parts, but return them for inspection/service.

During operation:

- Listen for unusual sounds and watch out for uneven running. Stop the actuator/lifting column immediately if anything unusual is observed.
- If the control box makes unusual noises or smells, switch off the mains voltage immediately and the external battery, if any.
- Take care that the cables are not damaged.
- Unplug the mains cable on mobile equipment before it is moved.

Troubleshooting Actuators / Lifting columns

Symptom	Possible cause	Action
No motor sound or movement of piston rod	- The actuator is not connected to the control box - Blown fuse in the control box - Cable damaged	- Connect the actuator to the control box - Fuse must be changed - Send actuator for repair
Excessive electricity consumption		- Send actuator for repair
Motor runs but spindle does not move	- Gear wheel or spindle damaged	- Send actuator for repair
Actuator cannot lift full load	- Clutch is worn - Motor is damaged	- Send actuator for repair
Motor sound but no movement of piston rod		- Send actuator for repair
No signal from Reed or Hall switch		- Send actuator for repair
Motor runs and quick release does not function or is noisy	- Declutching arm turns less than approx. 75°	- Adjust cable
Piston rod will only move inwards and not outwards	- Safety nut has operated	- Send actuator for repair
Motor runs too slowly or does not give full force	- Insufficient power supply - Voltage drop in cable	- Increase power supply - Thicker cable

Troubleshooting Electronics

Symptom	Possible cause	Action
Power indicator does not light up	- Not connected to mains	- Connect to mains
	- The fuse has blown	- Replace fuse, if the system is prepared for external fuse replacement, or send the system for repair
	- Defective power cable	- On control boxes with exchangeable power cable change the cable. - On control boxes with fixed cable send it for repair
	- Control box defective	- Send control box for repair
Power indicator lights up, but actuator does not run	- Actuator plug not pushed into control box properly	- Push actuator plug into control box properly
Relays in control box are heard clicking	- Actuator defective	- Replace actuator - Control box defective - Replace the control box
Power indicator lights up, but actuator does not run	- Control box defective	- Send control box for repair
No relay noise is heard from control box Not valid for CB20/CB6S OBF/CB16 OBF	- Handset defective	- Send handset for repair
Control box completely dead on battery and no relay clicking is heard	- Battery completely flat	- Charge battery
	- Battery defective	- Replace battery
Actuator does not run on battery, but relay clicking is heard	- Actuator plug not properly pushed into control box	- Push actuator plug properly into control box
	- Actuator defective	- Replace actuator
	- Control box defective	- Replace control box
Control box okay apart from one direction on one channel	- Handset defective	- Send handset for repair
	- Control box defective	- Send control box for repair

3. Information on specific actuators

1. LA22 (MEDLINE® CARELINE® TECHLINE®)

Item No. : 22D000-06052410
 Prod. Date : 2009.07.01 S.O.7654321
 Max Load : Push 350 IPX1
 Power Rate : 24 V= / Max.3.3 A
 Duty Cycle : Max. 10%

NOT TO BE OPENED BY UNAUTHORIZED PERSONNEL

P.O.123456-0001 MADE BY LINAK A/S DENMARK

The LA22 is an in-line actuator specially designed with a small overall dimension for easy use in industrial, agricultural, and rehabilitation products.

Thanks to its small outer dimensions and linear design, the LA22 is well suited for applications where installation space is limited, such as on wheelchairs.

2. LA23 (DESKLINE®)

DESIGNED IN DENMARK
 Item No. : 2362002000050B4
 Prod. Date : 2014.06.20 S.O.6151450
 Max Load : Push/Pull 1500 N IPX4
 Power Rate : 24 V= / Max. 2.3 A
 Duty Cycle : 10%, Max. 2 min. / 18 min.

NOT TO BE OPENED BY UNAUTHORIZED PERSONNEL
 NE PAS A OUVRIER PAR PERSONNEL NON-AUTORISE

P.O.2140274-0001 MADE BY LINAK A/S DENMARK

The LA23 is a small and strong push actuator (up to 2500 N). The LA23 can be used in various applications where size is important. The LA23 is e.g. ideal for adding tilt-function to a desk, so the table top can tilt or for adjustment in handicap kitchens.

Some of the benefits the LA23 offers you are:

- Compact design
- High lifting force
- Exchangeable cables

Usage:

- Duty cycle: 10%, 2 minutes continuous use followed by 18 minutes not in use
- Usage temperature: +5° - +40° normal operating temp.
-30° - +50° according to test conditions: ISO 7176-9
- Storage temperature: -45°C to +70°C (according to ISO 7176-9)
- Compatibility: DESKLINE Control boxes.
SLS must be ignored Up + Down in the CBD4, when configured for LA23 and in the CBD6S with old actuators.
- Approved according to EN60335-1 with CBD6S
- Fire category: Enclosure UL94-V0
- Cycles: The LA23 Life cycle test has been performed with a stabilised power supply (10% duty cycle) on a 200 mm stroke actuator at max. load at 5000 cycles



Warnings

- Do not sideload the actuator.
- Only use the actuator within specified working limits.
- When mounting the LA23 in the application ensure that the bolts can withstand the wear and that they are secured safely.
- If an actuator with stroke length below 50 mm is used, and the electrical end-stop switch fails, please be aware that the distance before reaching the mechanical end-stop will be prolonged. The extra distance will be 50 mm minus actual stroke length.
I.e. If an actuator with 20 mm stroke length is used and the switch fails, it will travel an additional 30 mm before reaching the mechanical end-stop.
- Instruction concerning the turning of the piston rod eye
When mounting and taking into use, it is not permitted to make excessive turns of the piston rod eye. In cases where the eye is not positioned correctly, it is permitted to first screw the eye down to its bottom position, at a maximum torque of 2 Nm (1), and thereafter a maximum half turn outwards again (2).





Recommendations:

- Do not place load on the actuator housing and do prevent impact or blows, or any other form of stress to the housing.
- Ensure that the cable lock is mounted correctly.
- Ensure that the duty cycle and the usage temperatures for LA23 actuators is respected.
- Ensure that the cable cannot be squeezed, pulled or subjected to any other stress.
- The LA23 is not suitable for use in outdoor applications where it can be exposed to sun and rain.
If outdoor use cannot be avoided, it is very important that the LA23 is mounted in a position where it is well shielded. It is up to the customer to provide the shielding. Furthermore, it will be good practice to ensure that the actuator is fully retracted in the "normal" position. The reason is that there will be a vacuum inside the actuator if it is extended which over time can lead to water entering the actuator.

The item numbers for ordering the Cable Lock are:

- Item number: 0231007 (light grey) for one cable lock (1 piece).
- Item number: 0231037 (black) for one cable lock (1 piece).

Below you see an instruction in how to mount and remove the cable lock from LA23.

a) Mount a cable lock:

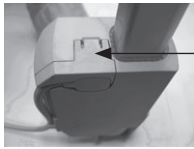

Push down until the cable lock clicks into place.

b) Cable lock removal



Step 1:
Insert e.g. a screwdriver at a 45° angle as illustrated.



Step 2:
Turn the screwdriver to release the cable lock.



Step 3:
Now the cable lock can be removed by hand.

Note: When a cable lock has been removed, it is recommended to replace it with a new.

3. LA23 (MEDLINE® CARELINE® TECHLINE®)



WE IMPROVE YOUR LIFE
DESIGNED IN DENMARK
 Item No. : 236200200050B4
 Prod. Date : 2014.06.20 S.O.8151450
 Max Load : Push/Pull 1500 N IPX4
 Power Rate : 24 V= / Max. 2.3 A
 Duty Cycle : 10%, Max. 2 min. / 18 min.

c/n 120690

NOT TO BE OPENED BY UNAUTHORIZED PERSONNEL
 NE PAS A OUVRIR PAR PERSONNEL NON - AUTORISE



P.O.2140274-0001 MADE BY LINAK A/S DENMARK



The LA23 is a small and strong push/pull actuator (up to 2500N). The LA23 can be used in various applications where size is important.

Some of the benefits the LA23 offers you are:

- Compact design
- High lifting force
- Exchangeable cables

Usage:

- Duty cycle: 10%, 2 minutes continuous use followed by 18 minutes not in use
- Usage temperature: +5° - +40° normal operating temp.
-30° - +50° according to test conditions: ISO 7176-9
- Storage temperature: - 45°C to + 70°C (according to ISO 7176-9)
- Compatibility: CB20, CB16, CB6S, CBJ 1/2, CBJC, CBJH, CBD4, CBD5 & CBD6*, CA30, CA40, CO61, and SMPS-T160 (for combination possibilities, please see the User Manual for SMPS-T160 on our website)
* SLS must be ignored Up + Down in the CBD4, CBD5 or CBD6 when configured for LA23
* Only the 3, 6 & 12 mm versions can be configured in the CBD4, CBD5 or CBD6
* Only tested for single use.
- Approvals: IEC60601-1:2005 3rd ed., ANSI / AAMI ES60601-1:2005, 3rd edition LA23 in combination with CBD4, 5 & 6 has no approvals
- Fire category: Enclosure UL94-V0



Warnings

- Do not sideload the actuator.
- Only use the actuator within specified working limits.
- Always use steel backfixture for LA23 over 1500N and for pull loads.
- The B and G 24V motors must only be used with their respective control box types.
 - Motor type A: 12V motor must be used with CBD4, CBD5 and CBD6
 - Motor type B: 24V motor which must be used with JUMBO; CBJ1/2, CBJC and CBJH or generally in applications which are mainly driven with battery
 - Motor type G: 24V motor which must be used with OpenBus™ control boxes; CB20, CB16, CB6S, CA30, CA40, CO61
- If an actuator with stroke length below 50 mm is used, and the electrical end-stop switch fails, please be aware that the distance before reaching the mechanical end-stop will be prolonged. The extra distance will be 50 mm minus actual stroke length. I.e. If an actuator with 20 mm stroke length is used and the switch fails, it will travel an additional 30 mm before reaching the mechanical end-stop. Please make sure that the application can withstand this in a safe way.
- Instruction concerning the turning of the piston rod eye. When mounting and taking into use, it is not permitted to make excessive turns of the piston rod eye. In cases where the eye is not positioned correctly, it is permitted to first screw the eye down to its bottom position, at a maximum torque of 2 Nm (1), and thereafter a maximum half turn outwards again (2).
- When mounting the LA23 in the application ensure that the bolts can withstand the wear and that they are secured safely.



Recommendations

- Do not place load on the actuator housing and do prevent impact or blows, or any other form of stress to the housing.
- Ensure that the cable lock is mounted correct.
- Ensure that the duty cycle and the usage temperatures for LA23 actuators is respected
- Ensure that the cable cannot be squeezed, pulled or subjected to any other stress.
- If a cable lock has been removed it is recommended to check if it is has been damaged during removal. If so it is recommended to replace with a new one.
- Before mounting a cable, ensure that the cable, cable plug or o-ring is not damaged. If damage is observed, the cable must be replaced with a new one.
- The B and G 24V motors must only be used with their respective control box types.
- Not acceptable: B motor with OpenBus™ control boxes!
Reason: The actuator will be too strong, it will run too fast, be noisy and only have a short lifetime. The actuator will not live up to what we promise.
- Not acceptable: G motor with 24V supply!
Reason: The actuator will be too weak, this means it will only run slowly, not be able to lift as much in the cold and under low current conditions. The actuator will not live up to what we promise.
- The LA23 is not suitable for use in outdoor applications where it can be exposed to sun and rain.
If outdoor use cannot be avoided, it is very important that the LA23 is mounted in a position where it is well shielded. It is up to the customer to provide the shielding.
Furthermore, it will be good practice to ensure that the actuator is fully retracted in the "normal" position. The reason is that there will be a vacuum inside the actuator if it is extended which over time can lead to water entering the actuator.

The item numbers for ordering the Cable Lock are:

- Item number: 0231007 (light grey) for one cable lock (1 piece).
- Item number: 0231037 (black) for one cable lock (1 piece).

Below you see an instruction in how to mount and remove the cable lock from LA23.

a) Mount a cable lock:



Push down until the cable lock clicks into place.

b) Cable lock removal



Step 1:
Insert e.g. a screwdriver at a 45° angle as illustrated.



Step 2:
Turn the screwdriver to release the cable lock.



Step 3:
Now the cable lock can be removed by hand.

Note: When a cable lock has been removed, it is recommended to replace it with a new.

Connection diagrams:

Standard electrical end stop - no positioning

23XXXXXX00XXXXX

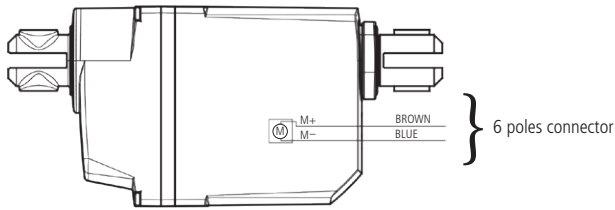

Standard electrical end stop and potential free end stop - no positioning

23XXXXXX01XXXXX

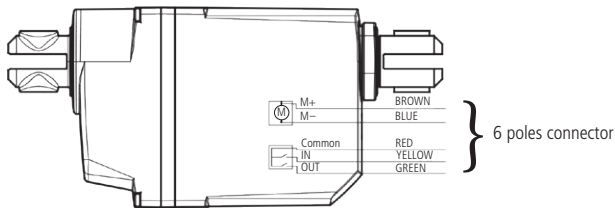

Dual Hall digital positioning

23XXXXXX02XXXXX

Dual Hall PNP positioning

23XXXXXX03XXXXX

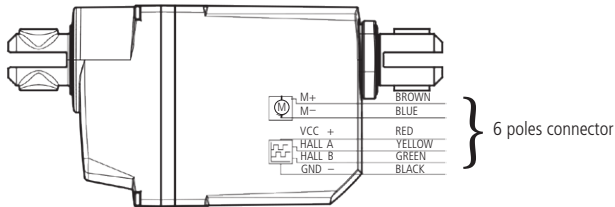

Note: Connection colours only fit with "open end" cables.



Note: If reversed driving is wanted this has to be done by using different cables.

Hall Potentiometer feedback and potential free end stop
 23XXXXXX2XXXXXX

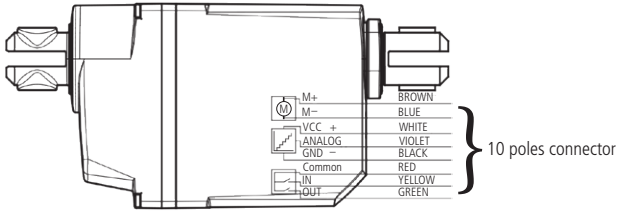

Hall Potentiometer feedback
 23XXXXXX1XXXXXX

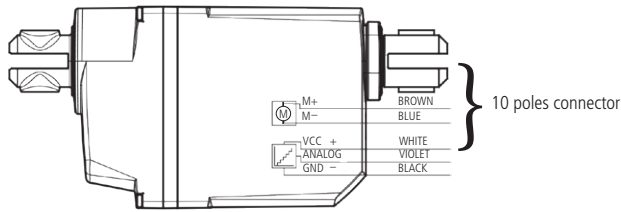

Hall PWM position feedback and potential free end stop
 23XXXXXX4XXXXXX

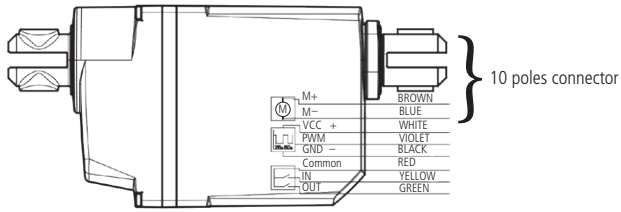

Note: Connection colours only fit with "open end" cables.

Hall PWM position feedback
23XXXXXX3XXXXXX

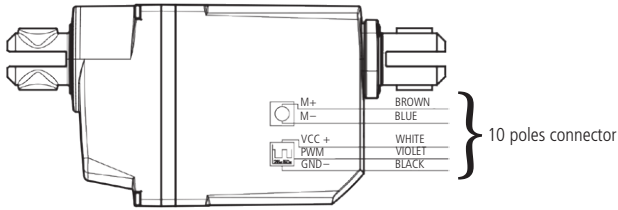

Standard Integrated Control
23XXXXXX5XXXXXX

Integrated Control with Hall Potentiometer position feedback
23XXXXXX6XXXXXX

Integrated Control with Hall PWM position feedback
23XXXXXX7XXXXXX

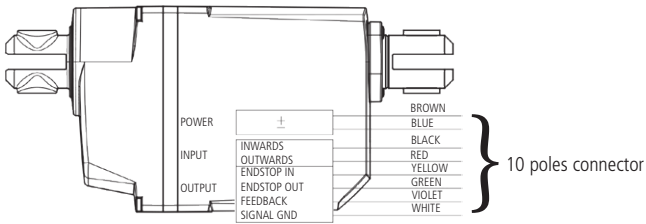

Drawing no.: 0239010-A



LA23 with integrated control is not approved according to IEC60601-1:2005 3rd ed., ANSI / AAMI ES60601-1:2005, 3rd edition.







Note: Connection colours only fit with "open-end" cables.

LINAK® 

WE IMPROVE YOUR LIFE

DESIGNED IN DENMARK
 Item No. : 2362002000050B4
 Prod. Date : 2014.06.20 S.O.6151450
 Max Load : Push/Pull 1500 N IPX4
 Power Rate: 24 V= / Max. 2.3 A
 Duty Cycle : 10%, Max. 2 min. / 18 min.

NOT TO BE OPENED BY UNAUTHORIZED PERSONNEL
 NE PAS A OUVRIER PAR PERSONNEL NON-AUTORISE

P.O.2140274-0001 MADE BY LINAK A/S DENMARK

CIN 12 0690

The LA23 is a small and strong push/pull actuator (up to 2500N). LA23 can be used in various applications where size is important. The actuator does have build in electrical limit switches and ground nut.

Usage:

- Duty cycle: 10%, 2 minutes continuous use followed by 18 minutes not in use
- Usage temperature: -30°C to +55°C (according to ISO 7176-9)
- Storage temperature: -45°C to +70°C (according to ISO 7176-9)
- Fire category: Enclosure UL94-V0



Warnings

- All LA23 IC (Integrated Controls) versions are not compliant for Medical use.
- Do not sideload the actuator.
- Only use the actuator within specified working limits.
- Always use steel backfixture for LA23 over 1500N and for pull loads.
- When mounting the LA23 in the application ensure that the bolts can withstand the wear and that they are secured safely.
- Motor type A: 12V motor
Motor type B: 24V motor.
- If an actuator with stroke length below 50 mm is used, and the electrical end-stop switch fails, please be aware that the distance before reaching the mechanical end-stop will be prolonged. The extra distance will be 50 mm minus actual stroke length. I.e. If an actuator with 20 mm stroke length is used and the switch fails, it will travel an additional 30 mm before reaching the mechanical end-stop.
- Instruction concerning the turning of the piston rod eye. When mounting and taking into use, it is not permitted to make excessive turns of the piston rod eye. In cases where the eye is not positioned correctly, it is permitted to first screw the eye down to its bottom position, at a maximum torque of 2 Nm (1), and thereafter a maximum half turn outwards again (2).



Recommendations

- Do not place load on the actuator housing and do prevent impact or blows, or any other form of stress to the housing.
- Ensure that the cable lock is mounted correctly.
- Ensure that the duty cycle and the usage temperatures for LA23 actuators is respected.
- Ensure that the cable cannot be squeezed, pulled or subjected to any other stress.

The item numbers for ordering the Cable Lock are:

- Item number: 0231007 (light grey) for one cable lock (1 piece).
- Item number: 0231037 (black) for one cable lock (1 piece). Below you see an instruction in how to mount and remove the cable lock from LA23.

a) Mount a cable lock:



Push down until the cable lock clicks into place.

b) Cable lock removal



Step 1:
Insert e.g. a screwdriver at a 45° angle as illustrated.



Step 2:
Turn the screwdriver to release the cable lock.



Step 3:
Now the cable lock can be removed by hand.

Note: When a cable lock has been removed, it is recommended to replace it with a new.

Connection diagrams:

Standard electrical end stop - no positioning

23XXXXXX00XXXXX

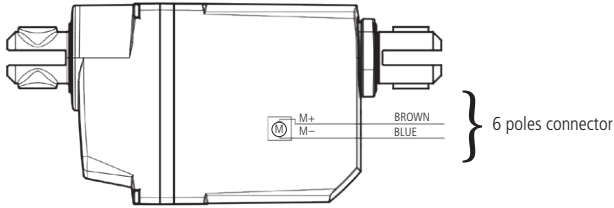

Standard electrical end stop and potential free end stop - no positioning

23XXXXXX01XXXXX

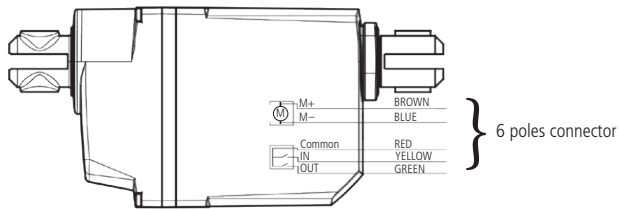

Dual Hall digital positioning

23XXXXXX02XXXXX

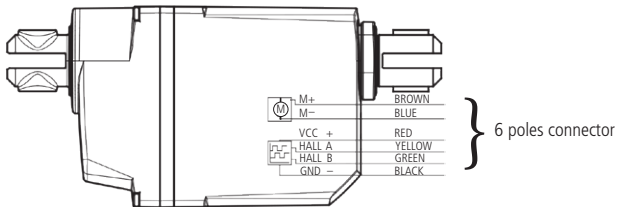

Dual Hall PNP positioning

23XXXXXX03XXXXX



Note: Connection colours only fit with "open end" cables.



Note: If reversed driving is wanted this has to be done by using different cables.

Hall Potentiometer feedback and potential free end stop
 23XXXXXX2XXXXXX

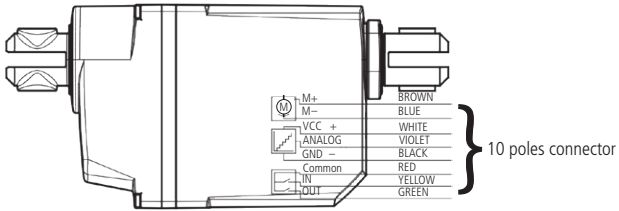

Hall Potentiometer feedback
 23XXXXXX1XXXXXX

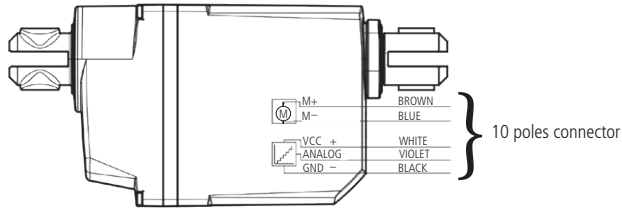

Hall PWM position feedback and potential free end stop
 23XXXXXX4XXXXXX

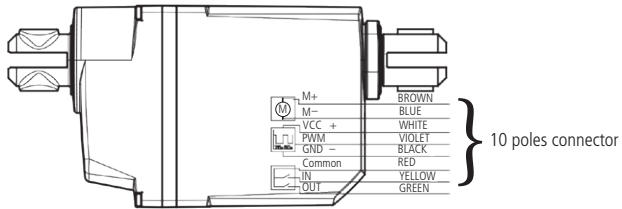

Note: Connection colours only fit with "open end" cables.

Hall PWM position feedback
23XXXXXX3XXXXXX

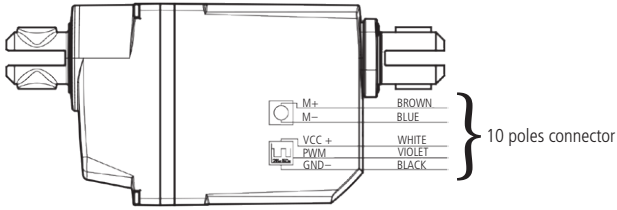

Standard Integrated Control
23XXXXXX5XXXXXX

Integrated Control with Hall Potentiometer position feedback
23XXXXXX6XXXXXX

Integrated Control with Hall PWM position feedback
23XXXXXX7XXXXXX

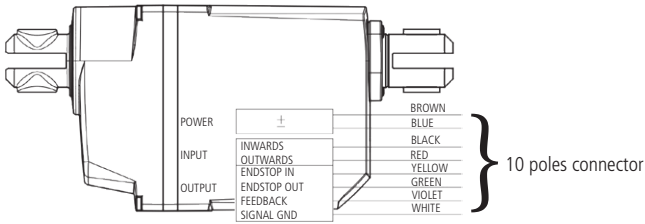

Drawing no.: 0239010-A



LA23 with integrated control is not approved according to IEC60601-1:2005 3rd ed., ANSI / AAMI ES60601-1:2005, 3rd edition.



Note: Connection colours only fit with "openend" cables.



LINAK®
WE IMPROVE YOUR LIFE

Item No. : 273100A01405040
 Prod. Date : 2009.03.18 S.O.7654321
 Max Load : Push 1500 N IPX4
 Power Rate: 24 V= / Max. 3.5 A
 Duty Cycle : Max. 10%

NOT TO BE OPENED BY UNAUTHORIZED PERSONNEL

P.O.123456-0001 MADE BY LINAK A/S DENMARK

The LA27 actuator is a powerful actuator designed for applications such as furniture and care beds.

Built-in end-stop circuit (CS27)

In the LA27/CS27 the actuator is switched off at the end position. There is no overload protection.

- The LA27CS27 has no IP classification and is connected to a HB71 or HB72. The power supply is the TR6 or TR7.

It is important that the supply voltage 24 VDC is connected correctly (see **Figure 6.7**) otherwise the CS-circuit may be destroyed.

Mechanical spline:

The splines function so that the actuator can only push, not pull. During pull in the actuator, the inner tube is lifted off the thread bush, and the actuator can therefore never pull a load, only push.

Functional test of mechanical splines:

When the piston rod is at the innermost position, it must be possible to pull it out manually to its full travel length and to press it in again without much resistance and without using the motor. If this is not possible, contact your nearest LINAK dealer.

Quick Release:

The LA27 with QR is designed to be used as a part of the backrest function in a Care/Hospital bed. The QR function allows a patient to be lowered manually to a flat position very quickly (CPR) in case of an emergency.

Functional test of QR:

To test a LA27QR it is necessary to have the actuator built into an application. The release cable has to be provided and mounted by the customer.

The necessary force on the cable required to operate the Quick Release is approx. 20 kg. The necessary force on the actuator to operate the quick release is approx. 50 kg. When operating the QR, it is recommended that the QR is activated all the way down.

Usage:

- Duty cycle: 2/18; 2 minutes continuous use followed by 18 minutes not in use
- Duty cycle: Max 5% or 1 min. continuous use followed by 19 minutes not in use - with 8000 N version.
- Lifetime limited to only 3000 cycles according to EN1970 - with 8000 N version
- Ambient temperature: +5° to +40°C (the actuator must also be at this temp.)
- Approvals: LA27 is approved according to the 3rd edition of IEC 60601-1, ANSI/AAMI ES 60601-1 and CAN/CSA C-22.2 No. 60601-1

NOTE: re. LA27 with 6.000N specification (274x3xxx1xxx0xZ; Z = A or B with worm shaft*) for OpenBus™: I.e. to use such combination a preceding test MUST be carried out.

This combination reduces the self-lock ability because of lower friction from the worm shaft which has a rolled axle. The worm shaft is however needed because of the OpenBus™ output power.

The problem related to an application:

The self-lock ability may be reduced in cases where the load curve is 6.000 N in both minimum and maximum stroke length.



Warnings

- The actuator must not be used in pull applications when the quick release is activated, as the risk of personal injury can arise.
- Do only use the actuator within specified working limits.
- Do not sideload the actuator.



Recommendations

- LA27 is not meant to have CB6S OBL/OBF mounted on the actuator. The CB6S OBL/OBF must be mounted separately using a bracket.
- LA27 must have a minimum installation dimension of 320 mm if control box CB6 is to be mounted on the actuator.
- The cable for the LA27 is not part of the actuator therefore it must be ordered separately.
- Piston rod eye: The distance from the centre of the eye, to the end of the actuator.
- Change between push and pull not allowed
- Inspect actuator once a year, for wear and jarring sound.
- We recommend using a safety nut in medical applications
- Do not expose actuators without all cables fitted to water/cleaning.
- No thread on bolt inside back fixture.

Note:

For CB6 the current will be cut off when the total current on all channels reaches approx. 5.1 to 5.4 Amp. This means that when two LA27's running simultaneously are connected to a CB6 they will not be able to lift the max. load mentioned under technical specifications.



Item No. : 281100+00100000
 Prod. Date : 2009.07.01 S.O.7654321

Max Load : Push 2000 IPX1
 Power Rate : 24 V $\overline{=}$ / Max.2.3 A

Duty Cycle : Max. 10%, Max. 2 min. / 18 min.

NOT TO BE OPENED BY UNAUTHORIZED PERSONNEL



P.O.123456-0001 MADE BY LINAK A/S DENMARK



The LA28 is primarily a system actuator. The actuator is very quiet and powerful designed for use in the furniture, rehabilitation, and hospital bed line of businesses.

The actuator is also ideal for use in agricultural machinery and for a wide range of industrial applications.

Reed-switch:

Reed-switch gives a number of pulses for each rotation of the motor. These pulses are used to calculate the piston rod's position as well as to control several actuators running in parallel.

Your nearest LINAK dealer can inform the number of pulses per stroke length.

Regarding Reed-switch connection, **Figure 6.8** (LA28R)

Built-in end-stop circuit (CS28/CS28S)

In the LA28 actuator, with built-in CS28 A-, B- or C-PCB, the actuator is switched off at the end position or when overloaded.

LA28 actuator with:

- The CS28 A is standard IPX1 and is connected to a HB41 handset with a telephone plug.
- The CS28 B is standard IPX5 and is connected to a HB41 handset with a DIN plug. CS32 B is also available in IPX6.
- The CS28 C is standard IPX1 and is connected to an external contact or control. **See figure 6.7.**

Mechanical spline:

The splines function so that the actuator can only push, not pull. During pull in the actuator, the inner tube is lifted off the thread bush, and the actuator can therefore never pull a load, only push.

Functional test of mechanical splines:

When the piston rod is at the innermost position, it must be possible to pull it out manually to its full travel length and to press it in again without much resistance and without using the motor. If this is not possible, contact your nearest LINAK dealer.



Warning

Do only use the actuator within specified working limits.

Usage:

- Duty cycle: Max. 10 % or max. 2 min. continuous use followed by 18 min. not in use.
- Ambient temperatures: + 5° to + 40°C
- Compatibility: CB8, CB12, CB14, and CBJ
- Approvals: IEC60601-1:2005 3rd edition, ANSI / AAMI ES60601-1:2005, 3rd edition and CAN / CSA-22.2 No 60601-1:2008 approved



Recommendations

- LINAK control boxes are designed so that they will short-circuit the motor terminals of the actuator(s), when the actuator(s) are not running. This solution gives the actuator(s) a higher self-locking ability. If the actuator(s) are not connected to a LINAK control box, the terminals of the motor must be short-circuited to enable self-locking of the actuator.
- The maximum load in pull is 2000 N.
- Min. stroke length for the LA28 with splines is 80 mm
- The current supply to LINAK actuators must be cut off in case of overload and when the actuators reach end position.
- Ambient operating temperature is 22°C.
- LA28 Compact cannot be used in pull applications, unless fitted with an aluminium back fixture.

Further information:

Noise level:

- LA28: dB(A) 45; measuring method DS/EN ISO 3743-1, actuator not loaded
- LA28S: dB(A) 54; measuring method DS/EN ISO 3743-1, actuator not loaded

Material:

- The piston rod eyes are "crimped" in place and cannot be unscrewed.

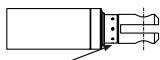

"Crimped" piston rod eye

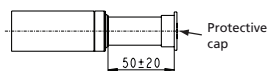

Piston rod without eye (are not tested)

6. LA28 Compact (MEDLINE® CARELINE® TECHLINE®)



WE IMPROVE YOUR LIFE

DESIGNED IN DENMARK

Item No. : 28110A-00100030
 Prod. Date : 2014.06.17 S.O.7654321
 Max Load : Push 2000 N IPX0
 Power Rate: 24 V = / Max. 2.3 A
 Duty Cycle : 10%, Max. 2 min. / 18 min.

NOT TO BE OPENED BY UNAUTHORIZED PERSONNEL
 NE PAS A OUVRIER PAR PERSONNEL NON-AUTORISE



P.O.12345678-0001 MADE BY LINAK A/S DENMARK

The LA28 Compact is a small and powerful actuator designed for use in system solutions for healthcare equipment or industrial applications. Ideal applications are for example wheelchairs, treatment chairs, patient lifts or beds.

Usage:

- Duty cycle: Max 10 % or max. 2 min. continuous use followed by 18 min. not in use.
- Ambient temperatures: + 5° to + 40°C
- Compatibility: CB8, CB12, CB14 and CBJ
- Approvals: IEC 60601-1:2005, 3rd edition, ANSI / AAMI ES60601-1:2005, 3rd edition and CAN / CSA-22.2 No 60601-1:2008 approved



Recommendations

- *LINAK control boxes are designed so that they will short-circuit the motor terminals of the actuator(s), when the actuator(s) are not running. This solution gives the actuator(s) a higher self-locking ability. If the actuator(s) are not connected to a LINAK control box, the terminals of the motor must be short-circuited to enable selflocking of the actuator.
- Min. stroke length for LA28 with splines is 80 mm
- The current supply to LINAK actuators must be cut off in case of overload and when the actuators reach end position.
- Ambient operating temperature is 22°C.
- LA28 Compact cannot be used in pull applications, unless fitted with an aluminium back fixture.

Further information:

Noise level:

- LA28: dB(A) 45; measuring method DS/EN ISO 3743-1, actuator not loaded
- LA28S: dB(A) 54; measuring method DS/EN ISO 3743-1, actuator not loaded

Material:

- The piston rod eyes are "crimped" in place and cannot be screwed loose.

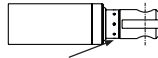

"Crimped" piston rod eye

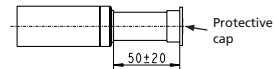

Piston rod without eye (are not tested)

7. LA29 (HOMELINE®)



WE IMPROVE YOUR LIFE

Item No. : 296100-0115005A
 Prod. Date : 2009.03.18 S.O.7654321
 Max Load : Push 1000 N
 Power Rate: 24 V = / Max. 3.5 A
 Duty Cycle : 10%, Max. 2 min. / 18 min.

NOT TO BE OPENED BY UNAUTHORIZED PERSONNEL



P.O.123456-0001 MADE BY LINAK A/S DENMARK

The LA29 actuator is a HOMELINE® actuator specially made for domestic applications. The actuator has a very short installation dimension as the distance between the two fixing points is small when the actuator is retracted and at the same time independent of the stroke length. This feature makes the actuator ideal as a lifting actuator for self-lifting recliners.

Another special feature here is the flexible back fixture, which can adapt misalignments in e.g. a recliner application.

The LA29 is compatible with various HOMELINE® control boxes.

Reed switch:

The Reed switch gives a number of pulses for each rotation of the motor. These pulses are used to calculate the position as well as to control several actuators running in parallel.

Your nearest LINAK dealer can inform the number of pulses per stroke length.

Regarding Reed-switch connection, **see Figure 6.10**.

Hall

The Hall principle is very similar to the Reed principle. A Hall sensor is based on a magnet that rotates. Two hall sensors are placed close to the magnet field. The control box (CB20/CB65 OBF/CB16 OBF/CBD4/CBD5) can detect whenever the magnetic field changes direction.

The two Hall sensors are placed close to each other, but with a small displacement. This distance leads to a timing difference between the two pulses. Whichever one of them comes first indicates the direction of movement. Therefore, there will be no error summary (as with the reed switch) Hall is therefore a very precise system. Hall is not suitable for use in quick release actuators - **see figure 10**.

Built-in end-stop circuit

The end-stop switch is part of the actuator construction. Each time the actuator reaches end-stop position the switch is activated and the current is cut off.



Warning

Do only use the actuator within specified working limits.



Designed in Denmark

DK - 6430 Nordborg

Item No. : 3011P0-00100504

Prod. Date : 2016.09.27

Max Load : Push 3000 N IPX0

Power Rate: 12 V = / Max. 16.5 A

Duty Cycle : 10%, Max. 2 min./18 min.

NOT TO BE OPENED BY UNAUTHORIZED PERSONNEL

NE PAS OUVRIR PAR DU PERSONNEL NON AUTORISÉ

W/O #2775610-0001 MADE BY LINAK A/S DENMARK



The LA30 is a powerful actuator yet small enough to fit most applications.

The actuator can be supplied with options such as built-in potentiometer for servo operation or an extra powerful motor for increased speed and strength (S-motor).

In addition to industrial and agricultural applications, the actuator is also ideal for positioning satellite dishes.

Reed-switch:

The Reed-switch gives a number of pulses for each rotation of the motor. These pulses are used to calculate the piston rod's position as well as to control several actuators running in parallel.

Your nearest LINAK dealer can inform the number of pulses per stroke length.

Regarding Reed-switch connection, see **Figure 6.10**.

Mechanical spline:

The splines function so that the actuator can only push, not pull.

During pull in the actuator, the inner tube is lifted off the thread bush, and the actuator can therefore never pull a load, only push. See **Figure 8**.

Functional test of mechanical splines:

When the piston rod is at the innermost position, it must be possible to pull it out manually to its full travel length and to press it in again without much resistance and without using the motor. If this is not possible, contact your nearest LINAK dealer.



Warning

Do only use the actuator within specified working limits.

Usage:

- Duty cycle: 10%, 2 minutes continuous use followed by 18 minutes not in use
- Ambient temperature: + 5° to + 40°C
- Storage temperature: - 40° to + 70°C
- Compatibility: CB8, CB12,
- Should the LA30 be used with a non LINAK control unit, please ask the nearest LINAK representative for further details



Recommendations

LINAK control boxes are designed so that they will short-circuit the motor terminals (poles) of the actuator(s), when the actuator(s) are not running. This solution gives the actuator(s) a higher self-locking ability. If the actuator(s) are not connected to a LINAK control box the terminals of the motor must be short-circuited to achieve the self-locking ability of the actuator.

Improved self-locking ability

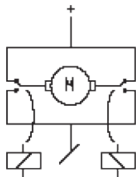

The H-bridge ensures that the motor is shorted when the relays are inactive. This is necessary to improve the self-locking of the actuator.



When using the LA30 with stereo jack plug be aware of the reversed direction of travel as standard.



The current supply to LINAK actuators must be cut off in case of overload when the actuators reach end position.

Various other information:

Noise levels:

LA30: dB(A) 50; LA30S: dB (A) 55; LA30L: dB(A) 48.

Measuring method DS/EN ISO 3743-1, actuator not loaded.

LINAK®

WE IMPROVE YOUR LIFE

DESIGNED IN DENMARK

Item No. : 311100+2015004E

Prod. Date : 2014.06.20 S.O.6415420

Max Load : Push 6000 N IPX4

Power Rate : 24 V = / Max. 4.3 A

Duty Cycle : 10%, Max. 2 min./18 min.

NOT TO BE OPENED BY UNAUTHORIZED PERSONNEL

NE PAS A OUVRIER PAR PERSONNEL NON-AUTORISE

CE, RoHS, and other compliance logos

P.O.2140274-0001 MADE BY LINAK A/S DENMARK

The LA31 is a compact, quiet and powerful actuator designed for a variety of applications in the MEDLINE® & CARELINE® segment, such as hospital beds, couches and nursing home beds.

The standard LA31 actuator features known parts such as piston rod eye with slot, and comes in different variations with e.g. fast motor, hall positioning and emergency lowering. The LA31 actuator has exchangeable cables and is ideal in combination with OpenBus™ control boxes.

The LA31 actuator has an ingress protection of IPX6 and is available in version with up to 6000N in push and 4000N in pull.

Usage

- Duty cycle: Max 10% or 2 minutes continuous use followed by 18 minutes not in use.
- Ambient temperature: + 5° to + 40°C
- The MEDLINE® & CARELINE® system has full compliance with EN 60601-1



Recommendations

- **LA31 with brake.** An LA31 brake in a push application brakes actively when the actuator moves in an inward direction. The same applies to an actuator mounted with a brake in a pull direction. It brakes in an outward direction. Under this condition the standard motor uses up to 4 Amp. and the fast motor uses up to 6 Amp. (Measured after 5 cycles at normal room temperature).
Therefore if the LA31 with brake is used together with a CB7 it is important that the current cut-off limit of the control box is higher than the used Amp. i.e. not lower than 4 Amp.
LA31 with brake cannot be combined with CB9/CB7 with emergency lowering. For all LA31 actuators with brake self-locking ability up to max. load it is only possible in one direction: push or pull.
- The LA31 actuator must not be exposed to more than 4000 N in pull. In applications where misalignments may occur the normal back fixture can take max. 1500 N in pull whereas the flexible back fixture can take up to 4000 N in pull.
The actuator must be mounted at right angles (90°) to it is fixing/load (max. 1.5° deviation)
- LA31 actuators with protection class IPX6 must be mounted with the screw holes mounted facing downwards.
To ensure that any water remaining from cleaning / washing is not collected in the screw holes.
- LA31 with internal quick release types A and B is not designed for use in pull.
- The necessary release force on an actuator with 5mm pitch is 75 kg for 6 mm pitch = 50 kg.
- LA31 with quick release is always with brake (push).
- The flexible back fixtures (05 or 06) must be standard when the LA31 is equipped with quick release.
- When operating the QR function of QR types A and B, the QR must be activated all the way down. Otherwise the QR will no longer function.
- The release cable has to be provided by the customer.
- The design of the release cable has to be as specified.
- It is important to observe the max. active (the moving part of the cable) cable length of 12 mm. Do not pull more than this length otherwise the QR will be damaged!
- The force required to operate the Quick Release is approx. 5 kg.
- When more than the recommended 5 kg force is used to activate the QR, more friction will be created in the internal actuator/QR mechanism.
This means that a greater load will be required to ensure successful operation.
- The QR cover is supplied attached to the actuator but not mounted.
- LA31 with external quick release, types I, K, L, and M can maximum pull 200N.
- The necessary release force on an actuator with 5mm pitch is 75 kg for 6 mm pitch = 50 kg.
- It is not possible to combine splines with the external quick release.
- LA31 with quick release is always with brake (push).
- The flexible back fixtures (05 or 06) must be standard when the LA31 is equipped with quick release.

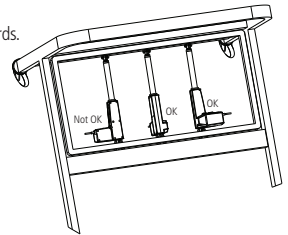

If electrical end stop fails to function the actuator will continue to retract or extend until mechanical end stop is reached.

The application of the customer must be able to obtain or withstand an actuator with failing electrical end stop.

Minimum length of actuator reaching mechanical end stop: nominal BID - 7 mm.

Maximum length of actuator reaching mechanical end stop: nominal BID + nominal SL + increase + 7 mm.



Warning

- If an LA31 is used in an application where there are repeated dynamic (push/pull) movements in the area 2000 – 4000 N, then it is necessary to contact LINAK A/S in order to make a correct specification of the actuator. Repeated push/pull movements cause extra strain to the actuator and can give safety considerations, the consequence being possible damage to the actuator.
- The LA31 actuator must not be exposed to more than 4000 N in pull. In applications where misalignments may occur, the normal back fixture can take max. 1500 N in pull, whereas the flexible back fixture can take up to 4000 N in pull.



LA31 actuators for patient hoists are marked with a label to ensure the user is aware that it is not permitted to handle the patient hoist by pulling the actuator or otherwise expose it to side forces.

LA31 with mechanical end stop - a first failure safe option:

In many applications our customers have approvals according to EN 60601-1.

The typical applications can be beds, massage couches etc.

In the norm, EN 60601-1, it is mentioned that the application must be first failure safe.

The manufacturer is responsible for making a risk analysis in order to check this. If a risk is identified it is the manufacturer of the application who makes sure that the risk is eliminated.

Normally the result of this risk analysis will state that the end stop switch in the LA31 would be questioned: Is this switch first failure safe?

The answer to this will be: No, a switch cannot be first failure safe. - In practical life we have discovered only very few defect switches.

Ask the customer: - What was the result of your risk analysis when you achieved the EN 60601-1 approval on your application?

There are several ways that an application can be made first failure safe:

- Use a mechanical stop in the application
- Use of a mechanical end stop in LA31 - is a possible option.
- Use an SLS (safety limit switch) in connection with the actuator.
- As a special solution we can offer LA31 with mechanical end stop with the same installation dimension as a standard LA31.

Contact LINAK A/S for further information if you need this solution.

LA31 with manual lowering

The purpose of the ML (Manual Lowering) is in case of a power failure, to be able to mechanically lower a patient by turning the ML part in the clockwise direction until the actuator is fully lowered.



Recommendations:

- An addition of 35mm to installation dimension compared to standard (with spline)
- Only for push applications
- Use spline actuators
- Cannot be retro fitted



WE IMPROVE YOUR LIFE

DESIGNED IN DENMARK

Item No. : 32K500-00150412

Prod. Date : 2014.06.20 S.O.6125402

Max Load : Push 6000 N IPX5

Power Rate: 24 V = / Max. 5.3 A

Duty Cycle : 10%, Max. 2 min./18 min.

NOT TO BE OPENED BY UNAUTHORIZED PERSONNEL

NE PAS A OUVRIR PAR PERSONNEL NON-AUTORISE

CE, RoHS, and other regulatory symbols.

P.O.2140274-0001 MADE BY LINAK A/S DENMARK

The LA32 actuator is a powerful actuator that can be supplied with a ball screw spindle to give outstanding performance. The ideal choice for a wide range of applications including adjustment of hospital beds.

The LA32 actuator has many special options including a safety nut, splines, quick release (F) and an optional protection up to IPX6 standard.

Reed-switch:

The Reed-switch gives a number of pulses for each rotation of the motor. These pulses are used to calculate the piston rod's position as well as to control several actuators running in parallel.

Your nearest LINAK dealer can inform the number of pulses per stroke length.

Regarding Reed-switch connection, see Figure 6.10.

Usage:

- Duty cycle: Max. 10% or 2 minutes continuous use followed by 18 min. not in use
- Ambient temperature + 5° to + 40° C
- For use with LINAK control boxes CB8, CB12, CB14 and CS16 PCB or internal CS32 PCB
- Should the LA32 be used with a non LINAK control unit, please ask the nearest LINAK representative for further details
- Approvals: IEC 60601-1:2005, 3rd edition, ANSI / AAMI ES60601-1:2005, 3rd edition and CAN / CSA-22.2 No 60601-1:2008 approved



Recommendations

- As there is friction in the spindle/gear system, a load of 800 N is necessary to start the lowering function with the LA32F. The actuator will use up to 3.5 Amp. in inward direction unloaded due to a brake system that is fitted as standard on all types of the LA32F.
- Release of the QR is only possible with a Bowden cable release force 25–60 N.
- The piston rod eyes are "crimped" in place and cannot be screwed loose.

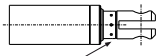

"Crimped" piston rod eye

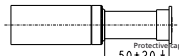

Piston rod without eye

- Piston rods without eyes have not been tested
- LA32 with quick release and freewheeling function must not be sold to new products



Maximum load in pull = 2000N



LA32 actuators for patient hoists are marked with a label to ensure the user is aware that it is not permitted to handle the patient hoist by pulling the actuator or otherwise expose it to side forces.

Freewheeling of piston rod

All LA32 actuators with freewheeling as well as with quick release have the designation W on the label.

The function causes the following:

- The piston rod can be pulled out with a thrust of approx. 300 N and it remains in the new position without declutching.
- The actuator cannot pull, but only push.

Functional test:

It must be possible to pull the piston rod out with a thrust of approx. 300 N and it must remain in the new position without releasing. If this is not possible, contact your nearest LINAK dealer.

Built-in end-stop circuit (CS32)

In the LA32 actuators, with built-in CS32 A-, B- or C-PCB, the actuator is switched off at the end position or when overloaded.

LA32 actuator with:

- The CS32 A is standard IPX1 and is connected to a HB41 handset with a telephone plug.
- The CS32 B is standard IPX5 and is connected to a HB41 handset with a DIN plug. CS32 B is also available in IPX6.
- The CS32 C is standard IPX1 and is connected to an external contact or control. See Figure 6.7.

Mechanical spline:

The splines function so that the actuator can only push, not pull. During pull in the actuator, the inner tube is lifted off the thread bush, and the actuator can therefore never pull a load, only push. **See figure 8.**

Functional test of mechanical splines:

When the piston rod is at the innermost position, it must be possible to pull it out manually to its full travel length and to press it in again without much resistance and without using the motor. If this is not possible, contact your nearest LINAK dealer.

Electrical splines:

In the rear fixture on the actuator, a microswitch is fitted, which turns off the motor, if the actuator is exposed to pull forces.

Functional test of electrical splines

When the actuator is correctly fixed/mounted, the inward movement of the piston must stop, when the actuator is pulled or the movement is blocked, so that the back fixture is not put under undue stress/tension. For mounting, see **Figure 7.**

Quick release

When the quick release arm, **see Figure 9,** is turned counter clockwise approx. 75° and fixed here, the piston rod is released and can now be pressed in to its innermost position or pulled out to its outermost position. When the quick release arm is released, the arm turns back and the actuator functions normally again. The cable must not be tight.



Warning

- If the actuator does not work as described above, the risk of injury due to squeezing can arise. Therefore, the actuator must immediately be sent for service at the nearest, authorised LINAK workshop.
- The actuator must not be used in pull applications when the quick release is activated, as the risk of personal injury can arise.
- Do only use the actuator within specified working limits.

11. LA34 (MEDLINE® CARELINE®)

WE IMPROVE YOUR LIFE
DESIGNED IN DENMARK
Item No. : 34420K-301502A0
Prod. Date : 2014.06.20 S.O.6125402 File E175209
Max Load : Push 3000 N
Power Rate: 24 V= / Max. 4 A
Duty Cycle : 10 %, Max. 2 min./18 min. IPX4

NOT TO BE OPENED BY UNAUTHORIZED PERSONNEL
NE PAS A OUVRIER PAR PERSONNEL NON-AUTORISE

P.O.2140274-0001 MADE BY LINAK A/S DENMARK

LA34 is a technological state-of-the-art actuator that, due to its innovative construction can push up to 10,000 N at a speed of 5 mm/sec. and with a current consumption of approx. 7 Amp. The strong LA34 actuator is made in a low weight composite material.

Its compact design, the outstanding performance and a wide range of safety options makes LA34 the right choice for a variety of medical and industrial applications.

Reed-switch:

The Reed-switch gives a number of pulses for each rotation of the motor. These pulses are used to calculate the piston rod's position as well as to control several actuators running in parallel.

Your nearest LINAK dealer can inform the number of pulses per stroke length. Regarding Reed-switch connection, **see Figure 6.10.**

Options:

- Mechanical spline: When using the actuator in a vertical position, the force needed to activate the mechanical spline is maximum 60 N + the weight of the application. To reengage the spline function, a force of maximum 60N is needed. Same installation dim. as standard actuator.
- A modified Bowden cable holder is available (as a special article), with better cable alignment and improved guidance of the cables.
- Electric spline: When using the actuator in a vertical position, the force needed to activate the electric spline is maximum 100 N + the weight of the application. To reengage the spline function, a force of maximum 100 N is needed.

Usage:

- Duty cycle: 2/18 – 2 minutes continuous use followed by 18 minutes not in use
- Ambient temperature: + 5° to + 40° C
- Compatibility: CB9 with EAS, CB12 with EAS, CB14*, CB18, CB20 and CBJ, CB6 OBL/ F, CB16 OBL/ F, (* = only possible with customized software)
- Approvals: IEC60601-1:2005 3rd edition, ANSI / AAMI ES60601-1:2005 3rd edition, and CAN / CSA-22.2 No 60601-1:2008 for LA34 24V zinc and composite versions.



Recommendations

- Power supply without current cut-off can cause serious damage to the actuator if mechanical stop is encountered or the actuator movement is blocked in another way.
- LINAK control boxes are designed so that they will short-circuit the motor terminals (poles) of the actuator(s) when the actuator(s) are not running. This solution gives the actuator(s) a higher self-locking ability. If the actuator(s) are not connected to a LINAK control box the terminals of the motor must be short-circuited to achieve the self-locking ability of the actuator.



Warning

An LA34 actuator is not designed for repeated dynamic push-to-pull movements. This causes extra strain to the actuator and can give safety considerations, the consequence being possible damage to the actuator. Therefore, if repeated dynamic push-to-pull movements are essential for the application, perform tests to validate the performance and use a steel piston rod eye (contact LINAK A/S).



LA34 actuators for patient hoists are marked with a label to ensure the user is aware that it is not permitted to handle the patient hoist by pulling the actuator or otherwise expose it to side forces.



Tests show that uneven running can occur when retracting the LA34 composite actuator with a low load below 500N. This has no impact on the safety of the actuator and is caused by internal frictions.

If the LA34 actuator is used in connection with a non-LINAK power supply the system must be equipped with current trip cut-off.

Adjustment of the installation dimension N

As standard the installation dimension on the LA34 actuator can be manually adjusted by +4/-0 mm (not possible for mechanical splines).

The adjustment of the installation dimension must only be made without use of tools only, or hand). It is not allowed to use tools to adjust the installation dimension of the LA34 actuator as there is a risk that the inner tube may be unscrewed.

Hall

The Hall principle is very similar to the Reed principle. It is a control box, which based on Hall signals, can decide whether the actuator runs out or in. Hall, however, can detect whether the actuator runs in or out. The number of pulses is like Reed. Hall and Reed are placed opposite the potentiometer on the actuator's worm wheel. Therefore, it is not suitable for use in quick release /free wheeling actuators. **see figure 10.**

Potentiometer

The potentiometer function is mechanically attached to the spindle and registers the number of spindle revolutions. The signal from the potentiometer is measured in Ohm, where the lowest value is measured when the actuator has been run into inward switch stop. The potentiometer is a 10-turn and therefore it is dependent on the stroke length/spindle pitch. **see figure 6.5**

Mechanical spline:

The splines function so that the actuator can only push, not pull. During pull in the actuator, the inner tube is lifted off the thread bush, and the actuator can therefore never pull a load, only push. See **Figure 8.**

Functional test of mechanical splines:

When the piston rod is at the innermost position, it must be possible to pull it out manually to its full travel length and to press it in again. When used in a vertical position the force needed to activate the mechanical spline is maximum 60N + the weight of the application. To reengage the spline function, a force of maximum 60 N is needed. If this is not possible, contact your nearest LINAK dealer.

Electrical splines:

In the rear fixture on the actuator, a microswitch is fitted, which turns off the motor, if the actuator is exposed to pull forces.

Functional test of electrical splines

It is important that the actuator is correctly fixed with regard to the section on page 11. For mounting, see **Figure 7.**

When the actuator is correctly fixed/mounted, the inward movement of the piston must stop, when the actuator is pulled or the movement is blocked, so that the back fixture is not put under undue stress/tension.

Quick Release

LA34 (34xxxF/H) is equipped with a function which permits operation of the actuator should the power source fail. Condition for functioning: the actuator must be loaded in push direction (LA34xxxF) or pull direction (LA34xxxH).



Warning

- If the actuator does not work as described above, the risk of injury due to squeezing can arise. Therefore, the actuator must be sent immediately for service at the nearest, authorised LINAK workshop.
- The actuator must not be used in pull applications when the Quick Release is activated, as the risk of personal injury can arise.
- Do only use the actuator within specified working limits.

Activation of Quick Release

Pull the release handle in the direction of the piston rod eye (outwards), the harder you pull the button the quicker the actuator runs down.

When releasing the button the emergency lowering stops immediately. The emergency lowering is activated as long as the load on the actuator is above 100-150 kg. The actuator is ready for normal use when the emergency lowering is finished.

Safety device regarding functional failure of the nut (Safety nut):

The LA34 has a built-in safety nut in push as standard and is available with a safety nut in pull as an option. Actuators with safety nut in push can only function when used in push applications. The safety nut comes into operation should the main nut fail.

Afterwards it is only possible to drive the actuator into the innermost position. Safety nut in pull is for pull applications and works the opposite way as described above. Thereafter, the actuator will not function any more and must be sent for service.

Built-in end-stop circuit

In the actuators mentioned the end-stop switch is part of the actuator construction. Each time the actuator reaches end-stop position, the switch is activated and the current is cut off.

LINAK® 

 WE IMPROVE YOUR LIFE
 DESIGNED IN DENMARK

Type : 400401000A000B26+32CB127522002

Item No. : J08477

Prod. Date : 2014.12.18

Max Load : Push 8000-5500 N IPX6

Power Rate: 24 V= / Max. 6.4 A

Duty Cycle : 10%, Max. 2 min. / 18 min.

 NOT TO BE OPENED BY UNAUTHORIZED PERSONNEL
 NE PAS OUVRIR PAR DU PERSONNEL NON AUTORISE

W/O #1234567-0001 MADE BY LINAK A/S DENMARK

The LA40 is a low noise and powerful actuator which is available in a 1500N, 4000N, 6000N and an 8000N version. Based on the extensive knowledge and experience from previous actuator families, LINAK has developed new gear and braking principles that improve the efficiency of the new LA40. These innovative solutions are covered by several patents.

Usage:

- Duty cycle: 10 %, 2 minutes continuous use, followed by 18 minutes not in use
- Usage temperature: 5 °C to 40 °C
- Compatibility: CBHA220A software 30002001 version 1.08
In combination with TD4 software version 30002001, Version 1.21
- Relative humidity: 20 % to 90 % @ 30 °C - not condensing
- Atmospheric pressure: 700 to 1060 hPa
- Approvals: Will be approved according to EN60335-1



Please note that extension of the built-in dimension may reduce the safety factor.



If electrical endstop fails to function the actuator will continue to retract or extend until mechanical endstop is reached. The application of the customer must be able to obtain or withstand an actuator with failing electrical endstop.
 Minimum length of actuator reaching mechanical endstop: BID - 7 mm.
 Maximum length of actuator reaching mechanical endstop: BID + SL + 7 mm.

Recommendations

- Power supply without current cut-off can cause serious damage to the actuator if a mechanical stop is encountered or the actuator movement is blocked in another way.
- Connection bolts must be dimensioned so that they have the necessary strength and tolerance in order to obtain the minimum safety factor according to the requirements of the authorities.
- The actuator must not be subject to a side load, as this can cause bending/collapse of the actuator. The actuator must never be used as a handle.
- The actuator must not be subject to off-centre loading, as this can cause bending/ collapse of the actuator.
- The actuator must not be subject to impact, or any form of stress to the casing.
- The actuator must not be subject to overload, as this can reduce the lifetime of the actuator and in the worst case cause damage to the actuator.
- The actuator must never be used in dynamic pull applications, as this can cause collapse.
- Only use the actuator within the specifications.
- Connection bolts and brackets are to be inspected in connection with service, and must be replaced if there are signs of wear.
- Ensure that the cable lock is mounted correctly.
- Ensure that the duty cycle and the usage temperatures for LA40 actuators are respected.
- Ensure that the cable cannot be squeezed, pulled or subjected to any other stress.
- The LA40 is not suitable for use in outdoor applications where it can be exposed to sun and rain.

Warning

- The installation of spline actuators is recommended by LINAK where possible to avoid the squeezing of body parts.
- End of life issue: defective switches - endstop:
If the electrical endstop switch for outward operation fails, it may cause a prolonged actuator stroke and in addition the customer application may collapse. To avoid this, the manufacturer must take this into account when designing and making a risk analysis.

Instruction concerning the turning of the piston rod eye

When mounting and taking into use, it is not permitted to turn the piston rod eye several times. In cases where the eye is not positioned correctly, the eye must be screwed to its bottom position (1) and then maximum half a turn outwards again (2).

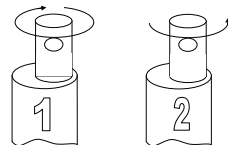
Mounting bracket instructions

To avoid damage to the actuator, it is important that the actuator drives to the application endstop position and continues to operate in the groove until it activates the electric actuator endstop.

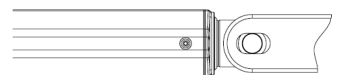





LINAK® 

WE IMPROVE YOUR LIFE
DESIGNED IN DENMARK

Type : 400401000A000B26+32CB127522002
Item No. : J08477
Prod. Date : 2014.12.18
Max Load : Push 8000-5500 N IPX6
Power Rate : 24 V $\overline{=}$ / Max. 6.4 A
Duty Cycle : 10%, Max. 2 min. / 18 min.

 NOT TO BE OPENED BY UNAUTHORIZED PERSONNEL
NE PAS OUVRIIR PAR DU PERSONNEL NON AUTORISE

 W/O #1234567-0001 MADE BY LINAK A/S DENMARK

The LA40 is a low noise and powerful actuator which is available in a 1500N, 4000N, 6000N and an 8000N version. Based on the extensive knowledge and experience from previous actuator families, LINAK has developed new gear and braking principles that improve the efficiency of the new LA40. These innovative solutions are covered by several patents.

Usage:

- Duty cycle: 10 %, 2 minutes continuous use, followed by 18 minutes not in use
- Usage temperature: 5 °C to 40 °C
- Storage temperature: -10 °C to 50 °C
- Relative humidity: 20 % to 90 % @ 30 °C - not condensing
- Atmospheric pressure: 700 to 1060 hPa
- Approvals: IEC60601-1, 3rd edition, ANSI, AAMI ES60601-1:2008, 3rd edition, and CAN / CSA 22.2 No 60601-1:2008, ND (National Deciation, AU/NZ)



If electrical endstop fails to function the actuator will continue to retract or extend until mechanical endstop is reached. The application of the customer must be able to obtain or withstand an actuator with failing electrical endstop. Minimum length of actuator reaching mechanical endstop: BID - 7 mm. Maximum length of actuator reaching mechanical endstop: BID + SL + 7 mm.



Recommendations

- Power supply without current cut-off can cause serious damage to the actuator if a mechanical stop is encountered or the actuator movement is blocked in another way.
- Connection bolts must be dimensioned so that they have the necessary strength and tolerance in order to obtain the minimum safety factor according to the requirements of the authorities.
- The actuator must not be subject to a side load, as this can cause bending/collapse of the actuator. The actuator must never be used as a handle.
- The actuator must not be subject to off centre loading, as this can cause bending/collapse of the actuator.
- The actuator must not be subject to impact, or any form of stress to the casing.
- The actuator must not be subject to overload, as this can reduce the lifetime of the actuator and in the worst case cause damage to the actuator.
- The actuator must never be used in dynamic pull applications, as this can cause collapse.
- Only use the actuator within the specifications.
- Connection bolts and brackets are to be inspected in connection with service, and must be replaced if there are signs of wear.
- Ensure that the cable lock is mounted correctly.
- Ensure that the duty cycle and the usage temperatures for LA40 actuators is respected.
- Ensure that the cable cannot be squeezed, pulled or subjected to any other stress.
- The LA40 is not suitable for use in outdoor applications where it can be exposed to sun and rain.
- LA40 with mechanical endstop - a first failure safe option:

In many applications customers have approvals in accordance with EN 60601-1. The typical applications are beds, massage couches etc.

The norm EN 60601-1 states that the application must be first failure safe.

The manufacturer has the responsibility of carrying out a risk analysis in order to check this. If a risk is identified, the application manufacturer must ensure that this risk is eliminated. A switch cannot be first failure safe.



Warning

- If the actuator does not work as described above, the risk of injury due to squeezing can arise. Therefore, the actuator must immediately be sent for service at the nearest, authorised LINAK workshop.
- The installation of spline actuators is recommended by LINAK where possible to avoid the squeezing of body parts.
- Activation of a quick release can lead to a risk of squeezing body parts. Installation of a damper may reduce this risk.
- A quick release can accidentally be activated during mounting or maintenance. To avoid this, operators must be warned before service/mounting.
- End of life issue: defective switches - endstop:

If the electrical endstop switch for outward operation fails, it may cause a prolonged actuator stroke and in addition the customer application may collapse. To avoid this, the manufacturer must take this into account when designing and making a risk analysis.

Instruction concerning the turning of the piston rod eye

When mounting and taking into use, it is not permitted to turn the piston rod eye several times. In cases where the eye is not positioned correctly, the eye must be screwed to its bottom position (1) and then maximum half a turn outwards again (2).

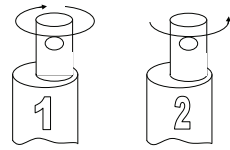

Mounting bracket instructions

To avoid damage to the actuator, it is important that the actuator drives to the application endstop position and continues to operate in the groove until it activates the electric actuator endstop.

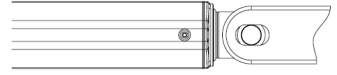

To avoid accumulated water inside the quick release lid (see illustration to the right) it is recommended not to mount the LA40 quick release actuator with the lid in downward position.

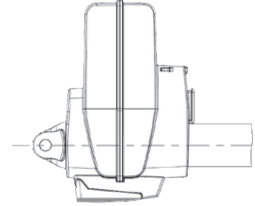

Mounting of the quick release cable:

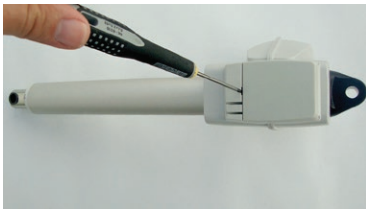

Open the quick release lid using a flat-head screwdriver. Push and twist in release hole.



Mount the cable in one of the assigned cable mounting holes. For dual release grips, use both holes. Place cable collar in groove.

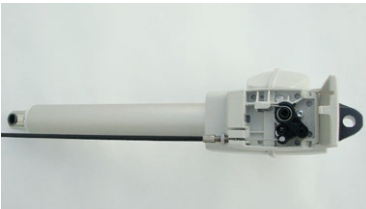

Adjust the cable with nut and make sure that the quick release is functional.

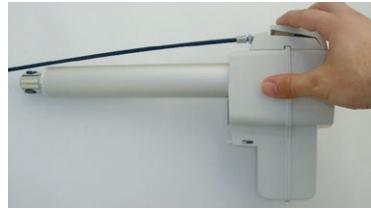

After closing the lid, the quick release is ready to be used.

Force required to operate the quick release is approximately:

- 35 N at 750 N load
- 60 N at 4000 N load

Travel of cable:

- travel until quick release approx. 15 mm
- maximum travel to endstop approx. 23 mm

The customer application design must ensure that the quick release cable cannot be pulled the full travel-to-end-stop with excessive pull force. This is to protect the quick release unit.

When operating the quick release function, the quick release must be activated all the way down and not stopped halfway.

LINAK **Designed in Denmark**
DK - 6430 Nordborg

Type : 43040390A000B4-212J106842D0100

Item No. : J15273

Prod. Date : 2016.12.14

Max Load : 8000 N IPX4

Power Rate: 24 V= / Max. 8 A

Duty Cycle : 10%, Max. 2 min./18 min.

NOT TO BE OPENED BY UNAUTHORIZED PERSONNEL
NE PAS OUVRIIR PAR DU PERSONNEL NON AUTORISE

W/O #-0001



The LA43 is available in a powerful 8,000N version, ensuring safe patient handling. With the LA43 actuator, LINAK offers a product, which with its wide range of safety options, low noise level, and outstanding performance is the right choice for medical applications such as patient lifts, beds, dental chairs etc.

Usage:

- Duty cycle: 10%, 2 minutes continuous use followed by 18 minutes not in use
- Usage temperature: +5°C to +40°C
- Storage temperature: - 10°C to + 50°C
- Compatibility: CBJ1/2, CBJ-Home, CBJ-Care, CB6S, CB16, CB20
- Approvals: IEC60601-1:2005 3rd edition

**Recommendations**

- The actuator is not suitable for outdoor applications
- Power supply without current cut-off can cause serious damage to the actuator if a mechanical stop is encountered or the actuator movement is blocked in another way.
- If there is a risk of "pull forces" in the application, the actuator must be equipped with electrical spline to avoid damage in pull.
- If the actuator is operated without load (e.g. loose on a table) the electrical spline can activate and the actuator cannot run in an inwards direction. Push the back fixture and the actuator can be operated again.
- Connection bolts must be dimensioned so that they have the necessary strength in order to obtain the minimum safety factor according to the requirements of the authorities.
- The actuator must not be subject to a side load, as this can cause bending. It is also for this reason that the actuator should not be used as a handle, e.g pulling a patient hoist sideways.
- The actuator must not be subject to off centre loading, as this can damage the actuator.
- The actuator must not be subject to impact, or any form of stress to the casing.
- The actuator must not be subject to overload, as this can reduce the lifetime of the actuator and in the worst case cause damage to the actuator.
- The actuator must not be used in pull applications, as this can cause collapse.
- Only use the actuator within the specified working limits.
- It is recommended that the actuator is serviced according to the relevant national norms for the applications in which the actuator is used.
- Connection bolts and brackets are to be inspected in connection with service, and must be replaced if there are signs of wear.
- The safety function: Electrical Spline, should be checked in connection with service. The function is checked by applying a straight pull, of max. 100 N, to the back fixture. The actuator must not be able to run in an inward direction. Hereafter press the back fixture against the housing and the actuator can run in an inward direction.
- The actuator should be cleaned regularly, in order to maintain a good hygiene.
- The application must be tested for correct functionality before putting it back into operation.
- Do not step or kick on the actuator as it may damage the housing or the motor.

Patient Lifts and Stand Aids:

- Long installation dimension: Must always be used for patient lifts.
- Do not hold the inner or outer tube while the actuator is running. There can be a risk of squeezing between the Manual Lowering unit and the outer tube.
- Do always use the electrical spline function for patient lifts



LA43 actuators for patient hoists are marked with a label to ensure the user is aware that it is not permitted to handle the patient hoist by pulling the actuator or otherwise expose it to side forces.

**Warnings**

It is not allowed to use tools to adjust the installation dimension of the LA43 actuator as there is a risk that the inner tube may be unscrewed.

Self-locking ability

- LINAK control boxes are designed so that they will short-circuit the motor terminals (poles) of the actuator(s), when the actuator(s) are not running. This solution gives the actuator(s) a higher self-locking ability. If the actuator(s) are not connected to a LINAK control box, the terminals of the motor must be short-circuited to achieve the self-locking ability of the actuator.



Manual lowering:

The following pictures illustrate the manual lowering procedure.

Fig. 1. Manual Lowering

In case of a power failure it is possible to mechanically lower a patient placed in a patient hoist. When turning the manual lowering handle clockwise the actuator can be moved fully inwards.

Fitting the plug/smart cable lock

The following pictures illustrate how to fit the plug connection using the smart cable lock manual lowering procedure.



Fig. 1

Step 1:

Insert the cable in the socket. Make sure the O-ring on the cable is fully inserted..



Fig. 2

Step 2:

Attach the cable lock. Make sure the inclined surface is facing upwards.

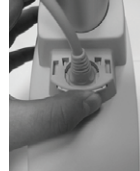

Fig. 3

Step 3:

Push the cable lock inside the slot. If necessary, the cable can be pushed down at the same time to ease the cable lock mounting.

LINAK 

Designed in Denmark

DK - 6430 Nordborg

Type : 43040205A050B6-2120103802D0210

Item No. : J14972

Prod. Date : 2016.12.14

Max Load : 8000 N IPX6

Duty Cycle : 10%, Max. 2 min./18 min.

 NOT TO BE OPENED BY UNAUTHORIZED PERSONNEL
 NE PAS OUVRIR PAR DU PERSONNEL NON AUTHORISE

W/O #-00001

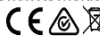
 ULus 120690

Software :02013513 Ver:1.00

The LA43 Intelligent Control (IC) enables a simple system consisting of 1 or 2 actuators, a Switch Mode Power Supply and a hand control or a footswitch. The system is for example an advantage when there is no space for a control box.

Usage:

- Duty cycle: 10%, 2 minutes continuous use followed by 18 minutes not in use
- Usage temperature: + 5° C to + 40° C
- Storage temperature: -10° C to + 50° C
- Compatibility: SMPS30
- Approvals: IEC60601-1:2005 3rd edition

**Recommendations**

- The actuator is not suitable for outdoor applications
- If there is a risk of "pull forces" in the application, the actuator must be equipped with electrical spline to avoid damage in pull.
- If the actuator is operated without load (e.g. loose on a table) the electrical spline can activate and the actuator cannot run in an inwards direction. Push the back fixture and the actuator can be operated again.
- Connection bolts must be dimensioned so that they have the necessary strength in order to obtain the minimum safety factor according to the requirements of the authorities.
- The actuator must not be subject to a side load, as this can cause bending. It is also for this reason that the actuator should not be used as a handle, e.g. pulling a patient hoist sideways.
- The actuator must not be subject to off centre loading, as this can damage the actuator.
- The actuator must not be subject to impact, or any form of stress to the casing.
- The actuator must not be subject to overload, as this can reduce the lifetime of the actuator and in the worst case cause damage to the actuator.
- The actuator must not be used in pull applications, as this can cause collapse.
- Only use the actuator within the specified working limits.
- It is recommended that the actuator is serviced according to the relevant national norms for the applications in which the actuator is used.
- Connection bolts and brackets are to be inspected in connection with service, and must be replaced if there are signs of wear.
The safety function: Electrical Spline, should be checked in connection with service.
The function is checked by applying a straight pull of max. 100 N to the piston rod.
The actuator must not be able to run in an inward direction.
Hereafter press the piston rod and the actuator can run in an inward direction.
- The actuator should be cleaned regularly, in order to maintain a good hygiene.
- The application must be tested for correct functionality before putting it back into operation.
- Do not step or kick on the actuator as it may damage the housing or the motor.

Safety concept:

The user is a part of the safety concept. A light on the SMPS30 is green when a button on the handset is not activated. When a switch is activated the light changes to orange. Orange indicates that power request is on.

When the light is orange and a button is not activated there is a fault on the system. And the user must call for service.

Cable connections:

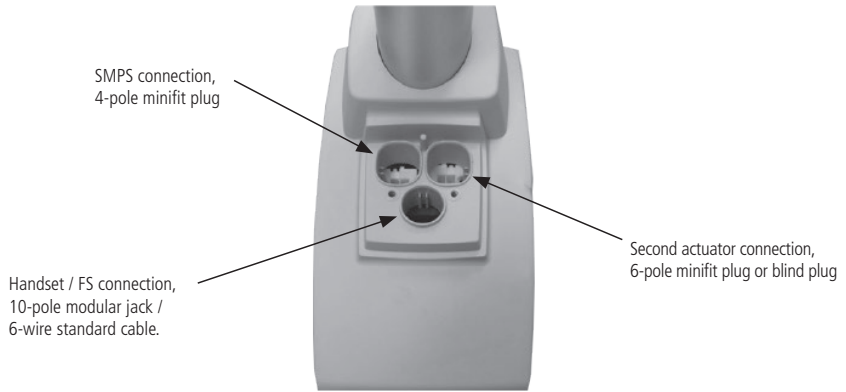
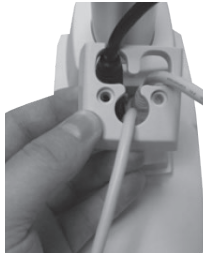

Fig. 1



Fig. 2



Step 1:

Insert the cables in the sockets.

Make sure the O-rings on the cables are fully inserted.

Step 2:

Insert the cables into the cable lock.

Make sure that the correct cables are placed in the corresponding holes.

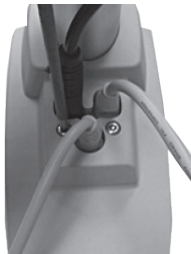

Fig. 3

Step 3:

Attach the cable lock and secure it with screws.

The tightening torque should be 0.4 Nm.

Cable connection and cable lock:

Tighten the two screws with approx. 0.4 Nm torque to secure the cable lock. Cable lock and screws to be ordered separately.



WE IMPROVE YOUR LIFE

DESIGNED IN DENMARK

Item No. : 442104+5L3001A0

Prod. Date : 2014.06.20 S.O.6412569 

Max Load : Push 12000 N

Power Rate : 24 V= / Max. 9.5 A

Duty Cycle : 10 %, Max. 2 min. / 18 min. IPX4

NOT TO BE OPENED BY UNAUTHORIZED PERSONNEL

NE PAS A OUVRIER PAR PERSONNEL NON-AUTORISE



P.O.2114579-0001 MADE BY LINAK A/S DENMARK

The LA44 is available in powerful 10,000 N and 12,000 N versions, ensuring safe patient handling.

With the LA44 actuator, LINAK offers a product, which with its wide range of safety options, low noise level, and outstanding performance is the right choice for medical applications such as patient lifts, beds, dental chairs etc.

Usage:

- **Electrical spline functionality:** Electrical spline; can be combined with manual lowering. The Electrical-spline switch is mounted inside LA44. It activates on a pulling movement of the slightly moveable back fixture. When using the actuator in a vertical position, the force needed to activate the electric spline is maximum 100 N + the weight of the application. To reengage the spline function, a force of maximum 100 N is needed.
- **Mechanical spline functionality:** When using the actuator in a vertical position, the force needed to activate the mechanical spline is maximum 60 N + the weight of the application. To reengage the spline function, a force of maximum 60 N is needed. 10%, 2 minutes continuous use followed by 18 minutes not in use
- **Duty cycle:** 10%, 2 minutes continuous use followed by 18 minutes not in use
- **Usage temperature:** 5°C to 40°C
- **Storage temperature:** - 10°C to + 50°C
- **Compatibility:** CBJ1/2, CBJ-Home, CBJ-Care, CB6s, CB16, CB20
- **Approvals:** IEC60601-1:2005 3rd edition, ANSI, AAMI ES60601-1:2005, 3rd edition, and CAN / CSA 22.2 No 60601-1:2008.



Recommendations:

- The actuator is not suitable for outdoor applications
- Power supply without current cut-off can cause serious damage to the actuator if a mechanical stop is encountered or the actuator movement is blocked in another way.
- If there is a risk of "pull forces" in the application, the actuator must be equipped with mechanical or electrical spline to avoid damage in pull.
- If the actuator is operated without load (e.g. loose on a table) the electrical spline can activate and the actuator cannot run in an inwards direction. Push the back fixture and the actuator can be operated again.
- Connection bolts must be dimensioned so that they have the necessary strength in order to obtain the minimum safety factor according to the requirements of the authorities.
- The actuator must not be subject to a side load, as this can cause bending. It is also for this reason that the actuator should not be used as a handle, e.g. pulling a patient hoist sideways.
- The actuator must not be subject to off centre loading, as this can damage the actuator.
- The actuator must not be subject to impact, or any form of stress to the casing.
- The actuator must not be subject to overload, as this can reduce the lifetime of the actuator and in the worst case cause damage to the actuator.
- The actuator must not be used in pull applications, as this can cause collapse.
- Only use the actuator within the specified working limits.
- It is recommended that the actuator is serviced according to the relevant national norms for the applications in which the actuator is used.
- Connection bolts and brackets are to be inspected in connection with service, and must be replaced if there are signs of wear.
- The safety function: Electrical Spline, should be checked in connection with service.
The function is checked by applying a straight pull, of max. 100 N, to the back fixture. The actuator must not be able to run in an inward direction. Hereafter press the back fixture against the housing and the actuator can run in an inward direction.
- The actuator should be cleaned regularly, in order to maintain a good hygiene.



LA44 actuators for patient hoists are marked with a label to ensure the user is aware that it is not permitted to handle the patient hoist by pulling the actuator or otherwise expose it to side forces.

Self-locking ability.

- LINAK control boxes are designed so that they will short-circuit the motor terminals (poles) of the actuator(s), when the actuator(s) are not running. This solution gives the actuator(s) a higher self-locking ability. If the actuator(s) are not connected to a LINAK control box, the terminals of the motor must be short-circuited to achieve the selflocking ability of the actuator.

Manual lowering:

The following pictures illustrate a) The manual lowering procedure and b) How to fit and remove the plug connection using the "Smart cable lock"



Fig. 1. Manual Lowering

In case of a power failure it is possible to mechanically lower a patient placed in a patient hoist. When turning the manual lowering handle clockwise the actuator can be moved fully inwards.

Fitting the plug/smart cable lock

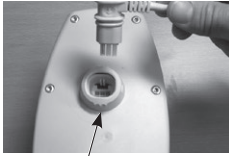

Fig. 1

Step 1: The three flanges in this position indicate that the "smart cable locking" device is in the unlocked position.



Fig. 2

Step 2: Position and press the cable plug into the socket.

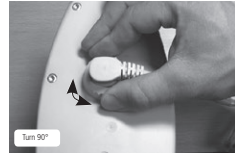
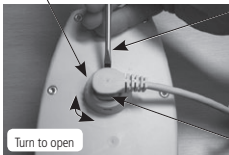

Fig. 3

Step 3: Hold around the lock flanges and turn the lock either clockwise or anticlockwise. The cable is fully locked when turned 90°.

Unlocking the plug/smart cable lock

Flanges in locked position



Press here with tool

Fig. 1

No tap on this side

Using a tool, release the lock (must be from the side shown) by pushing the tap (through the small slot in the side of the lock).

At the same time, turn the lock 90° in either direction to release the plug connection.



WE IMPROVE YOUR LIFE

DESIGNED IN DENMARK

Item No. : 442200+1L3001AG

Prod. Date : 2014.06.20 S.O.6178941

Max Load : Push 12000 N

Power Rate: 24 V= / Max. 9.5 A

Duty Cycle : 10 %, Max. 2 min. / 18 min. IPX4

NOT TO BE OPENED BY UNAUTHORIZED PERSONNEL

NE PAS A OUVRIER PAR PERSONNEL NON-AUTORISÉ



P.O.2114579-0001 MADE BY LINAK A/S DENMARK



The LA44 Intelligent Control (IC) enables a simple system consisting of 1 or 2 actuators, a Switch Mode Power Supply and a hand control or footswitch.

The system is for example an advantage when there is no space for a control box.

Usage:

- Duty cycle: 10%, 2 minutes continuous use followed by 18 minutes not in use
- Usage temperature: + 5° C to + 40° C
- Storage temperature: -10° C to + 50° C
- Compatibility: SMPS30
- Approvals: IEC60601-1:2005 3rd edition, ANSI / AAMI ES60601-1:2005 3rd edition pending

Cable connections:

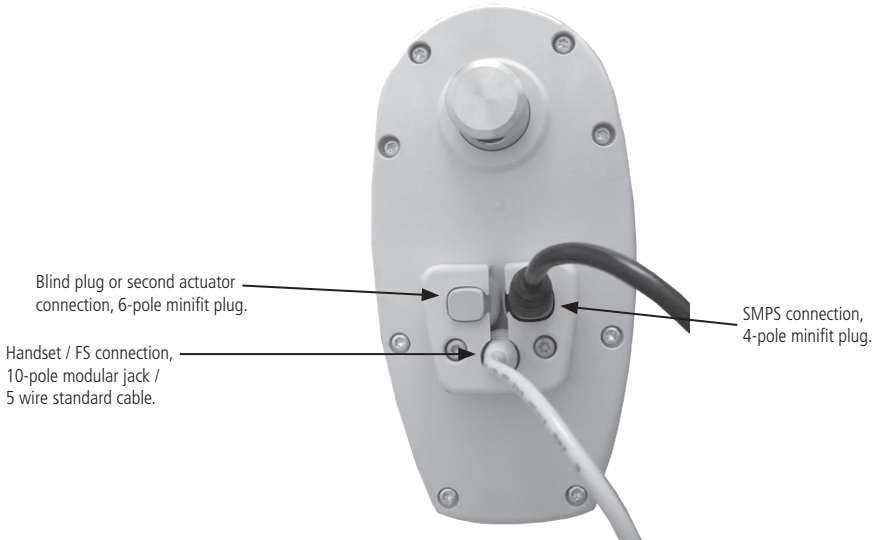

Cable connection and cable lock

Tighten the two screws with approx. 1.5 Nm torque, to secure the cable lock.

Precautions, Recommendations and Warnings - please see LA44 user manual

4. Information on specific columns

1. BB3 (MEDLINE® CARELINE®)



WE IMPROVE YOUR LIFE

DESIGNED IN DENMARK

Item No. : BB3610A03400345

Prod. Date : 2014.06.20 S.O.6145789

Max Load : Push 1600 N IPX0

Power Rate: 24 V= / Max. 3.5 A

Duty Cycle : 10 %, Max. 2 min./18 min.

NOT TO BE OPENED BY UNAUTHORIZED PERSONNEL
NE PAS A OUVRIR PAR PERSONNEL NON-AUTORISE



P.O.2114579-0001 MADE BY LINAK A/S DENMARK



The BB3 3-part telescopic actuator is the ideal choice for vertical lift of beds where design and easy integration in the customer's guidance ensures optimum freedom of design.

The BB3 is a 3-part telescopic actuator designed to meet EN 1970 for care beds, which demands an adjustment range from 350 mm up to 750 mm.

Reed-switch:

The Reed-switch gives a number of pulses for each rotation of the motor. These pulses are used to calculate the piston rod's position as well as to control several actuators running in parallel.

Your nearest LINAK dealer can inform you of the number of pulses per stroke length.

Regarding reed-switch connection, see **Figure 6.10**.

- The columns must be securely mounted before operation, no rotation must be possible
- The motor housing must be mounted uppermost.



Warning

Do only use the column within specified working limits.

2. BL1 (MEDLINE® CARELINE® TECHLINE®)



WE IMPROVE YOUR LIFE

DESIGNED IN DENMARK

Item No. : BL1411A01400A

Prod. Date : 2014.06.20 S.O.6148789

Max Load : Push 2000N IPX6

Power Rate: 24V= / Max. 4.4 A

Duty Cycle : 10%, max. 2 min./18 min.

NOT TO BE OPENED BY UNAUTHORIZED PERSONNEL
NE PAS A OUVRIR PAR PERSONNEL NON-AUTORISE



P.O.2114579-0001 MADE BY LINAK A/S DENMARK



CIN 120690



The BL1 is a 3-part lifting column designed to be used for example in Hospital beds, Nursing Home beds, Treatment chairs, Couches and Dental chairs.

The lifting column is compact and has a long stroke length. The 3-part guidance enables an overlap between the individual profiles, which ensures a high degree of stability.

The lifting column has an open spindle actuator with a chain drive inside which is practically noiseless.

Usage:

- Duty cycle: 10%, 2 minutes continuous use followed by 18 minutes not in use
- Usage temperature: +5°C to +40°C
- Storage temperature: Max 50°C
- Compatibility: CB6 OBL, CB6 OBF, CB16 and CB20
- Approvals: IEC60601-1:2005 3rd ed., ANSI / AAMI ES60601-1:2005, 3rd edition, CAN / CSA-22.2 No 60601-1:2008



Important:

If the actuator(s) are not connected to a LINAK control box, the terminals of the motor must be short circuited to guarantee the self-locking ability of the actuator.



Recommendations

- Please follow the important BL1 mounting guidelines.
- Max. storage temperatures: +50°C.
- BL1 is for use in push applications, cable outlet from smallest profile (top) or biggest profile (bottom). See top and bottom plate dimensions.
- When washing according to IPX6 parameters, it is not allowed to splash water directly onto the plastic frames between the profiles. Direct splashing is only permitted on the aluminium profiles.



Warnings

- BL1 is heavy (9.8 kg) To avoid personal injury, DO NOT DROP !
- Do not adjust anything during movement, can cause personal injury !
- LINAK recommends using a safety nut in medical applications !
- A broken chain causes a drop of half the length of actual stroke. Therefore do not overload !
- The BL1 is designed for use in push applications, dynamic "Pull forces" can result in damage to the column and cause collapse of the application.
- Do not loosen any screws on the BL1, this can cause collapse of the column !
- LINAK recommends making regular measurement of Class 1 protective ground conductivity in the application to avoid a disconnected grounding cable. Worn out or defect parts must be replaced.

BL1 end plate kit without cable through:

Top plate dimensions:

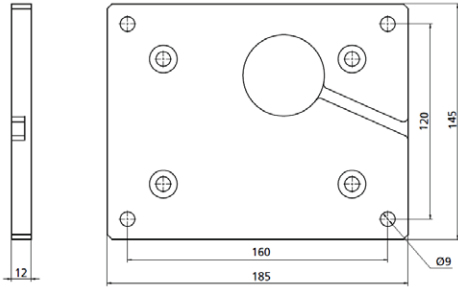

Bottom plate dimensions:

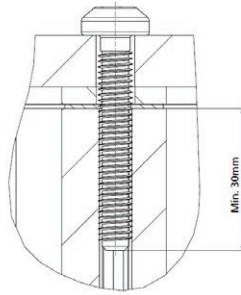
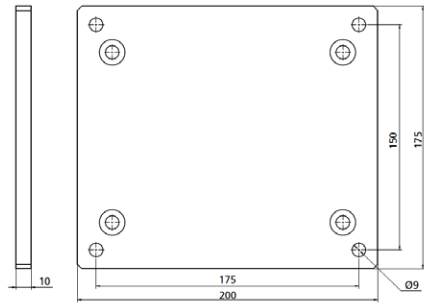

BL1 end plate kit with cable through:

Top plate dimensions:

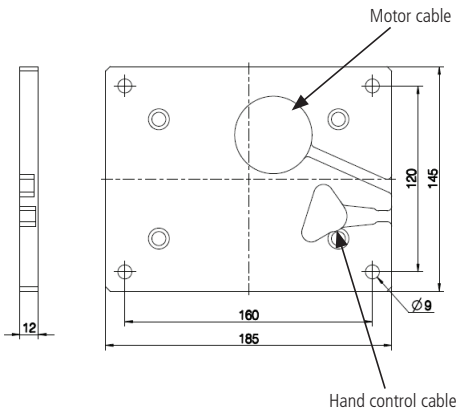

Bottom plate dimensions:

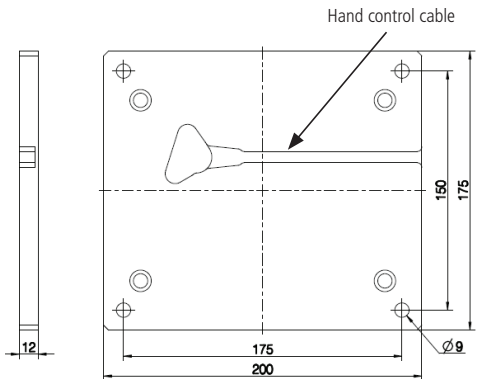

Please notice the thickness of the bottom plate is 12 mm. The thickness of the bottom plate without connections is 10 mm.

Mounting of BL1 with cable through:

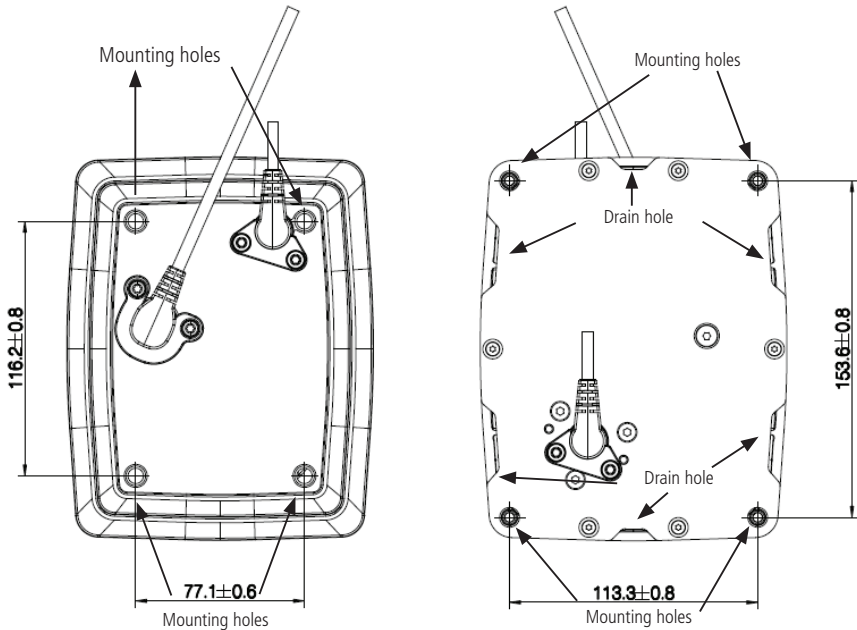

Drawing no.: 0807001-1



The mounting plate in the application must cover the entire top plate of the BL1 and be strong enough to carry the load.



Remember to secure the cable mounted in the top of the column to the application, so that it cannot be pulled out of the column.

We recommend to use LINAK Cable:

- Lock kit for BL1 with motor cable: 0808040
- Lock kit for BL1 with hand control cable through: 0808046

Use only the screws included in the kit. Screw torque: 2.7 Nm.



Electro Static Discharges!

There is no electrical connection through the length of the BL1 column. Therefore, to avoid ESD issues, consider external potential alignment between the top and bottom of the bed frame.

To connect for further earth wiring in the application, use an appropriate $\varnothing 8\text{mm}$ cable shoe under one of the 8 mm screws at both the top plate and the bottom plate.







Remember to mount the blind plugs in the top plate if the motor cable is connected from the bottom plate to ensure the IPX6 protection.



WE IMPROVE YOUR LIFE
DESIGNED IN DENMARK
Type : BL46XRA03400A
Item No. : BL40007-00
Prod. Date : 2012.07.13 S.O.7654321
Max Load : Push 1600 N IPX6
Power Rate: 24 V =

Duty Cycle : Max. 10%, Max 2 min./ 18 min.
NOT TO BE OPENED BY UNAUTHORIZED PERSONNEL

P.O.1234567-0001 MADE BY LINAK A/S DENMARK

The BL4 is a 4-part lifting column specially designed for hospital and care beds; the BL4 can of course be used for other applications where a compact lifting column with a long stroke length is needed.

The lifting column is based on the BB3 actuator, which is practically noiseless. The specifications comply with the demands to the lifting functions in beds as to load, speed and stroke length.

Reed-switch:

Reed-switch gives a number of pulses for each rotation of the motor. These pulses are used to calculate the piston rod's position as well as to control several actuators running in parallel.

Usage:

- Duty cycle: up to 10% or max. 2/18 min.
- Ambient temperatures: + 5° to + 40° C
- Compatibility: CB9AF, AL, AM, CB12H (special version), CB14 and OpenBus™ control boxes e.g. CB20

Technical specification:

Load in push :	Max. 1500 N See label
Load in pull (dynamic):	0N
Load in pull (static) :	Max. 600 N
Bending moment (static) :	Max. 500 Nm
Bending moment (dynamic) :	Max. 250 Nm
Duty cycle:	10% Max. 2 min./18 min. See label
Protection classes:	IPX4, IPX6 and IPX6 Washable
Usage temperature:	+5°C to +40°C
Storage temperature:	Max. 50°C

Your nearest LINAK dealer can inform the number of pulses per stroke length.

Regarding Reed-switch connection, **see Figure 6.10.**

- There are mounting holes in the endplates and motor housing
- The columns must be securely mounted before operation, no rotation must be possible
- The motor housing must be mounted uppermost
- The mounting bracket tension must be adjusted correctly



Warnings

- Do only use the column within specified working limits.
- The BL4 is heavy (8.2 kg) To avoid personal injury, DO NOT DROP!
- Do not adjust anything during movement, can cause personal injury!
- The BL4 is designed for use in push applications, dynamic "Pull forces" can result in damage to the column and cause collapse of the application.
- Do not loosen any screws on the BL4, this can cause collapse of the column!
- IPX6 washable versions must not be dismantled and then rebuilt again without the motor housing being changed in order to ensure the washability.
- There must be at least 4 hours between each washing cycle to allow the BL4 to resume normal temperature.



Recommendations

- Max. storage temperatures: +50°C.
- BL4 is for use in push applications only and only mounted with the motor housing uppermost.
- Actuators using "buffer" end-stop principle are not compatible with BL4 and CB9 systems.
- If the column is driven in end-position (end-stop switches in the actuator will be activated) and if the handset is kept activated you will in some cases, depending on the column load, see that the actuator starts and stops as long as the handset is activated.

Recommendations with washable versions:

- IPX6 Washable versions must not be dismantled and then be rebuilt again without the motor housing being changed in order to ensure the washability.
- There must be at least 4 hours between each washing cycle to allow the BL4 to resume normal temperature.

BL4 Mounting guidelines:



- The BL4 must always be mounted vertically before operation and always vertical with the motor housing uppermost. (Otherwise, the internal end-stop switch system can break due to rotation).
- Both the motor housing and the bottom tube (the one with the largest diameter) must be secured in the application in such a way that no rotation can occur.
- It is recommended to monitor the current consumption in order to determine the necessary tensioning force for the mounting bracket. If the current consumption rises the BL4 has been tightened too much.

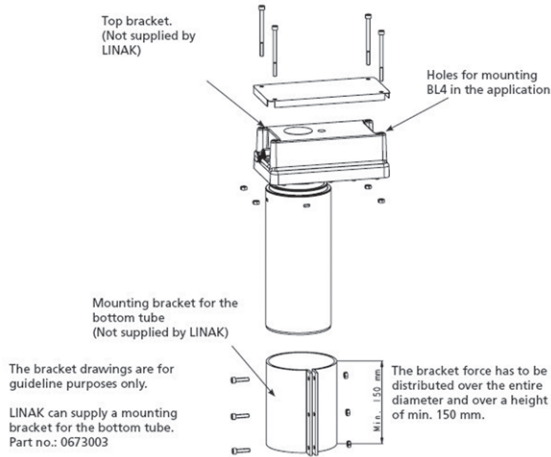

- The mounting plate in the application must cover the entire top plate of the BL1 and be strong enough to carry the load.
- It is recommended that all 4 holes in the motor housing are used to fasten the BL4 to the application.
- The screws must provide a secure fixing e.g. as with self-locking.
- Remember to secure the cable to the housing with a cable tie. Use the fixing eye next to the connector socket.

• Electro Static Discharges!

Be aware that there is no electrical connection through the length of the BL4 column. Therefore, to avoid ESD issues, consider external potential alignment between the top and bottom of the bed frame.

When mounting more than one BL4 you need to consider the fixation:

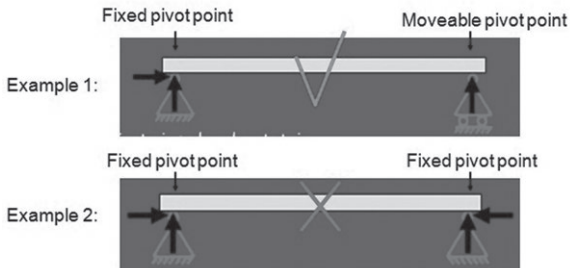

The reason why it is important only to fix one column is that the columns will not move exactly in parallel – even if you have positioning such as hall.

If more than one column is fixed, it can lead to dangerous situations.

If you have trend/antitrend function in your application you need to mount one or more of the BL4s with a slider.

Having sliders prevents the column from bending like illustrated below.

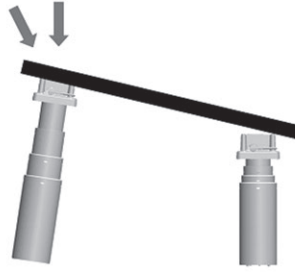
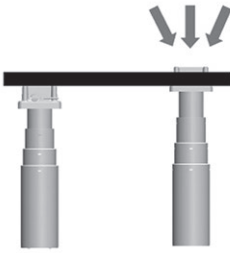

LINAK mounting bracket part no.: 0673003-A

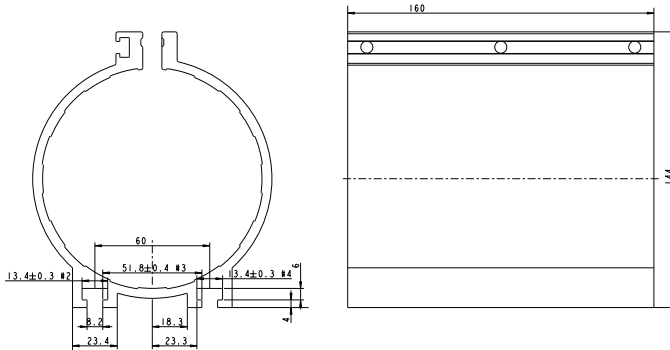

Mounting guidelines for the BL4 bracket, supplied by LINAK, part no. 0673003:

Mounting the bracket in the application:

- The bracket must be mounted to an even abutting plate in the application by using the 2 slits.
- In each slit at least 3 bolts must be mounted. Type M8 8.8.
- Tightening moment must be 22.7 - 26.1 Nm.
- The 3 bolts must be placed in the same height as the 3 holes.

Mounting of the BL4 into the bracket:

- The BL4 must be fitted in the bracket after mounting the bracket to the application.
- 3 bolts and nuts must be mounted in the 3 holes. Type M6 8.8
- Tightening moment must be 10.3 ± 0.3 Nm



The mounting points must be re-tightened at least once a year with the above specified moments.

4. LC2 (MEDLINE® CARELINE® TECHLINE®)

LINAK WE IMPROVE YOUR LIFE	"CAUTION: NOT TO BE OPENED BY UNAUTHORIZED PERSONNEL" WARNING: Improper use of an actuator may cause injury or damage. Contact LINAK for application advice before installing.
ITEM NO : LC22-U001-00	MADE BY LINAK A/S DENMARK
INSTALL : 807	
PROD. DATE : 2009.03.18 P.O. 123456-0001	
MAX. LOAD : Push 1500 N	
POWER RATING : 24 V _{DC} / Max. 4.6 Amp	
DUTY CYCLE : 10 % Max. 2 min. / 18 min.	



The LC2 column is an update of the LP2 programme. It has an improved "twisting" stability and end-stop switches as standard.
The column is designed to be used in a vertical position and only for lifting purposes. It is not possible to use the column in any kind of "pull" application.

Depending on the application, the LC2 can be operated either as a single column or several columns in a parallel system by choosing a control box with microprocessor.



It is designed to provide vertical lifting (push only) where simultaneous bending and torsion moments may occur.



Warning

Do only use the column within specified working limits.

5. LP2 (DESKLINE® MEDLINE® CARELINE® TECHLINE®)

LINAK 
WE IMPROVE YOUR LIFE
DESIGNED IN DENMARK
Item No. : LP22AR000300505
Prod. Date : 2014.06.20 S.O.6154781
Max Load : Push 2600 N
Power Rate : 24 V _{DC} / Max. 4.5 A
Duty Cycle : 10% Max. 2 min./18min.
NOT TO BE OPENED BY UNAUTHORIZED PERSONNEL NE PAS A OUVRIER PAR PERSONNEL NON - AUTORISE

P.O.2114579-0001 MADE BY LINAK A/S DENMARK



The LP2 range of vertical lifting columns is ideal where vertical positioning of substantial loads is required.

The design allows the LP2 range to be built in a complete motion control system simply by adding a suitable LINAK control box and handset.

Advanced design and high quality construction allows the column to be operated either as single or parallel with up to a maximum of four units and/or with a memory function.

The LP2 lifting column is the ideal choice for duties such as height adjustment on computer workstations, work benches, or a wide selection of other duties.

- There are mounting holes in the end plates.
- The largest profile must be mounted uppermost.



Warning

Do only use the column within specified working limits.



Warning

Ensure a safe connection between column and application



Warning

Side mounting bracket screws: use the correct torque on the side mounting bracket screws.



Warning

The column can not be used in pull



Warning

Max. bending: LP22 = 550 Nm
LP25 = 1000 Nm



WE IMPROVE YOUR LIFE

DESIGNED IN DENMARK

Item No. : LP36AROM0600550

Prod. Date : 2014.06.20 S.O.614528

Max Load : Push 2400 N

Power Rate: 24 V \approx / Max. 8 A

Duty Cycle : 10%, Max. 2 min./18 min.

NOT TO BE OPENED BY UNAUTHORIZED PERSONNEL

NE PAS A OUVRIR PAR PERSONNEL NON-AUTORISE



P.O.2114579-0001 MADE BY LINAK A/S DENMARK

The LP3 is developed for vertical lifts and can resist a bending moment by virtue of the effective telescopic system.

The lifting column is designed for applications where a small installation dimension is requested without compromising the lifting capacity.

The LP3 is characterised by having a lower installation dimension proportional to the stroke length compared to the LP2. The LP3 can also attain a higher speed than the LP2.

The telescopic column is compatible with LINAK's control boxes and can run individually; as 2 x LP3 parallel and/or with memory.

The LP3 is the perfect choice for height adjustment on dental, gynaecologist, and wheelchairs as well as for operating, office and working benches etc.



The column can only be loaded with the maximum bending moment over the first 80% of the stroke. The maximum bending moment will be reduced to 50%.



The column must be mounted with the largest profile uppermost!

- There are mounting holes in the end plates.
- The largest profile must be mounted uppermost.



Warning

Do only use the column within specified working limits.



Warning

Ensure a safe connection between column and application



Warning

Side mounting bracket screws: use the correct torque on the side mounting bracket screws.



Warning

The column can not be used in pull



Warning

Max. bending: LP3 = 375 Nm

5. Information on specific control boxes

Please be aware if the control box is not visible after mounting, all information regarding limitation of use shall be marked on the end product.

Output voltage

On control boxes connected to the mains the voltage of the actuator output is dependent on load, and the no-load voltage can reach 50 V. Control boxes connected to a battery can reach a voltage of 30 V during charging and no load.

For all control boxes with battery

Prior to first use of LINAK batteries, please make sure that they are being charged 24 hours in order to reach proper function and prolong the lifetime of the batteries.



Warning

Please observe the following maintenance, replacement, and disposal requirements to ensure a safe and reliable operation.

Maintenance of batteries

The batteries are to be replaced after 4 years at the latest. Perhaps earlier, dependent on the pattern of use. Frequent and high-powered discharges reduce the battery life. For an optimum lifetime the product must be connected to the mains voltage as often as possible. It is recommended that the batteries are to be charged at least every 3rd month - otherwise will the batteries have reduced capacity due to self-discharge. It is recommended to test the battery function at least once every year.

Replacement of batteries

The batteries must only be replaced by the same type of batteries or mechanical and electrical equivalent types. The batteries must be new or maintained by means of charging at least every 3rd month. The batteries, which make a set, must be supplied with identical production codes. Mismatching of production codes may lead to a severely reduced life time expectancy.

Before mounting ensure that the battery set is correctly connected, compare with the drawing in the battery room, and check that no connectors are loose.



Warnings

From the factory the battery room is hermetically separated from the electronics room. When replacing the batteries this separation must not be damaged or modified as this may allow penetration of battery gas into the electronics room with risk of explosion.

When replacing batteries in waterproof products (IPX5 and IPX6) precautions must be taken that the sealing material (silicone ring or joint filler) is not damaged and that it is correctly placed in the groove. Hereafter the screws in the cover are to be fastened with approx. 1 Nm. If the seal is damaged it must be replaced by a new silicone string (LINAK article no. 0008004 for a roll of 100 metres).

Disposal

The batteries, which are lead-acid batteries, can be returned to LINAK or disposed in the same way as car batteries.



Warnings

The battery room is supplied with ventilation that ensures correct and necessary airing of the battery room. This airing must not be blocked or covered as a positive pressure may occur with risk of explosion.

If the product has been exposed to mechanical overload (lost on the floor, collision/squeezing in the application or a powerful stroke) the product must be sent to an authorised workshop for control of the hermetic separation between the battery and electronics rooms.

Using control boxes with speed control

The common way of carrying out a speed control of the actuators is by using PWM, switching the motor on/off at a high frequency.

In rare cases, while switching the motor on/off, we have experienced that the coupling between the actuators and application frame and ground is too high, thus generating a slight current noise which exceeds the allowable EMC limits. The current in question is extremely low and is in no way related to any personal or patient risk.

The coupling is defined by the mechanical layout of the application, and no real guidelines can be given. Using plastic bushings or similar can improve the application.

If an application faces this issue, it can easily be solved by connecting ground of the CB box to the application frame-, through a cable with built in serial connection of a resistor and a capacitor.

The EMC test defined in IEC60601-1-2, applicable for all medical products, will show if this is an issue concerning the specific applications.

If you need more information or have any issues on this subject, please contact your LINAK A/S Sales contact.

Design criteria when using a customized CB

When using a customized CB together with a LINAK actuator, the interface connection between the CB vs. Actuator as well as the purpose of the actuator (with or without feedback) must be considered.

Actuators with feedback

E.g. potentiometer solutions have certain technological characteristics due to the design that might cause quality issues if used outside the specification range.

The connection interface

The connection interface is not only the compatibility of the plug types used, e.g. male mini-fit to female mini-fit plug type.

It is also considering the contact transition, i.e. the cable as well as the cable connector, the connecting plug, the material surface of the plug PIN, the soldering of the PCB plug connector etc.

When however using a LINAK Actuator with feedback AND having a bad connection interface towards a Customized CB – LINAK only guarantees the feedback voltage to be within 500 mV (+/- 250 mV).

1. CA30/CA40 (MEDLINE® CARELINE®)

LINAK 

Designed in Denmark
DK - 6430 Nordborg

Type : CA3+09211N09000

Item : J11331



Date : 2016.10.31

U In : 100-240 V~, 50/60 Hz

I In : Max. 2.5 A

IPX6 Washable

Int. : 10%, max. 2 min. / 18 min.



W/O #1234567-0001 ASSEMBLED IN CHINA

U In : 100 V~, 50/60 Hz 200VA
U Out : 30V=4A
Int.: 4A, 80s / 2A, 40s / 0A, 18 min.
LINAK K.K.
UL-US

LINAK 

Designed in Denmark
DK - 6430 Nordborg

Type : CA4+09411N09000

Item : J11332



Date : 2016.10.31

U In : 100-240 V~, 50/60 Hz

I In : Max. 2.5 A

IPX6 Washable

Int. : 10%, max. 2 min. / 18 min.



W/O #1234567-0001 ASSEMBLED IN CHINA

U In : 100 V~, 50/60 Hz 200VA
U Out : 30V=4A
Int.: 4A, 80s / 2A, 40s / 0A, 18 min.
LINAK K.K.
UL-US

The control boxes CA30 and CA40 are developed as part of a new control box platform for the care and rehab industry.

The control boxes can be mounted separately on the application by means of unique slide-on brackets, but also on several actuator models using a specially designed actuator bracket.

Usage:

- Duty cycle: 10 % - 2/18 min. on/off continuous use.
Maximum power is 120 W for 80 seconds and 60 W for 40 seconds at 25° C

LED indicator

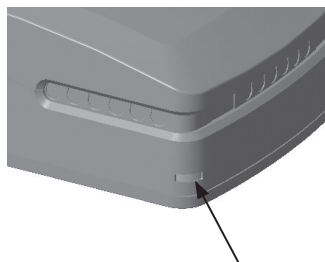

CA30/CA40 is equipped with a three-colour LED for indication of mains or battery operation.

Connected to MAINS	
LED colour	Indication of operation
Green	On mains, <u>not</u> activated by hand or foot control. The system is working ok and is ready for normal operation
Yellow	On mains, <u>not</u> activated by hand or foot control. The system is defective and should not be operated.
Yellow	On mains, activated by hand or foot control. The system is working.

Not connected to mains but with BATTERY back-up	
LED colour	Indication of operation
Orange	On battery, activated by hand or foot control. The system is working
No LED	On battery, <u>not</u> activated by hand or foot control. or CA30/CA40 not connected to mains

Mounting instructions (Example CA30-CA40 with LA40)

When mounting the control box onto the actuator (1)

Simply slide on the bracket until you hear a clear click (2)

Slide on the control box until you hear a click and the box is mounted (3)

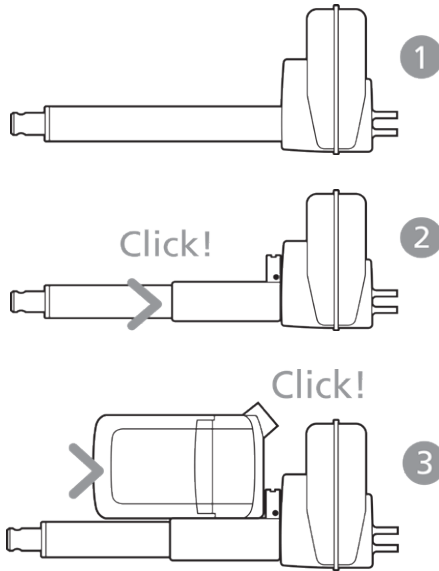

CA30-CA40 - mounted on frame:

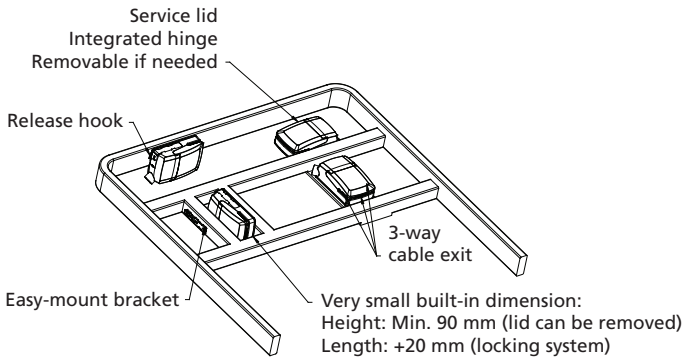

Mounting bracket (frame flat)

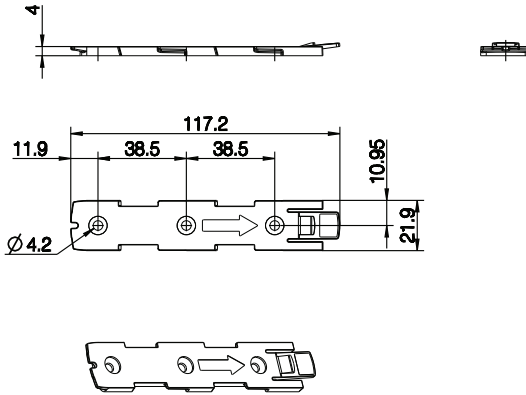

It is recommended that the CA30/CA40 is mounted in a position that allows water to escape.

Recommended torque: 0.6 Nm \pm 0.1

The bracket can be mounted to the bed frame or any other application by means of one of the following mounting procedures:

- 1) M6 nut to be placed in bracket and fixed with M6 bolt from the rear side.
- 2) M5 machine screw with flat washer to be fixed through bracket with nut on the rear side.
- 3) Self-tapping screw to be placed through bracket and onto the frame.

Mounting bracket (frame flat) w/M4 nuts

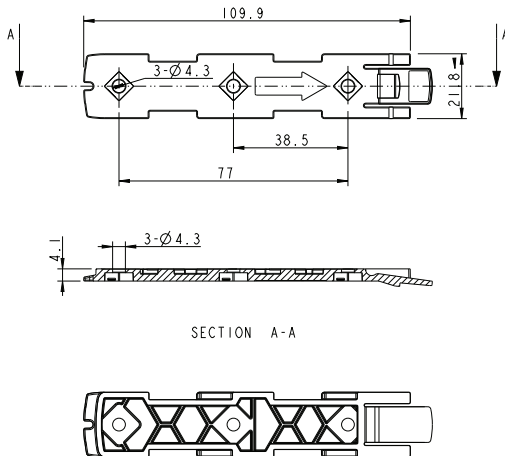

It is recommended to mount the CA30/CA40 in a position that allows water to escape.

Recommended torque: 0.6 Nm \pm 0.1

The bracket can be mounted to the bed frame or any other application by means of one of the following mounting procedures:

- 1) M6 nut to be placed in bracket and fixed with M6 bolt from the rear side.
- 2) M5 machine screw with flat washer to be fixed through bracket with nut on the rear side.
- 3) Self-tapping screw to be placed through bracket and onto the frame.

Mounting of cables and cable lock:

The control boxes CA30/CA40 have a uniquely designed cable lid. The lid also works as an integrated cable lock when closed.

- 1) Mount cable plugs in control box
- 2) Close lid until lock snaps into place (see arrows)

To allow free access to the cables, the lid has a rest position when completely opened.

It is possible to remove the lid by lifting it a few degrees and pulling it away from the housing under tight mounting conditions.

See illustrations:

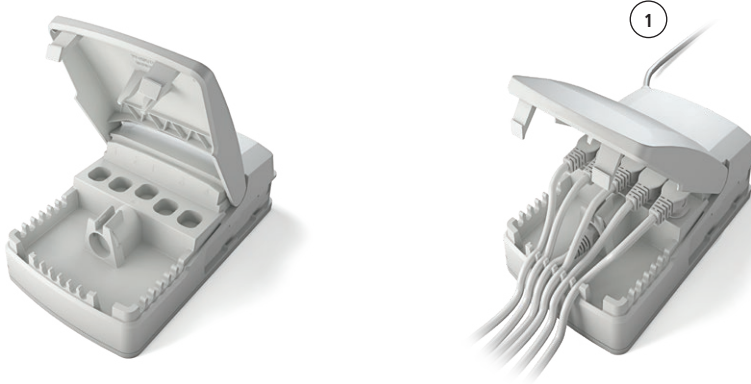

Cable management:

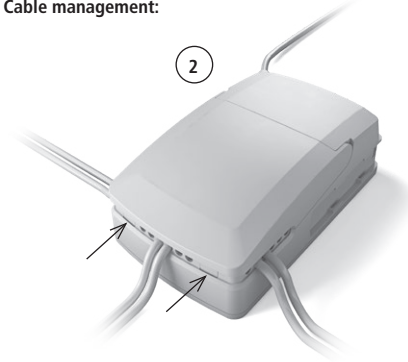

Recommendations

- Note that the common current limit on CA30-CA40 is 8 A and may cause overload on certain actuator types.
- Be aware that the channel configuration has been changed compared to existing analogue control boxes.
- To avoid unintended movement like trend or antitrend, LINAK recommends the application manufacturer to instruct the end user to avoid that multiple keys are pressed simultaneously.

Battery Operation

CA30 and CA40 are only compatible with batteries with built-in charger, BA19 or BA21.

EOP- electronic overload protection

Remark - common/individual current measurement.

As default, the current cut-off is set to 8 A per channel. The total current cut-off default setting is 8 A. If more channels run at the same time, 8 A are distributed equally.



Warnings

- Due to the half-bridge technology, pressing multiple keys simultaneously might cause an unintended trend or antitrend movement (application environment 4).