



# TEST REPORT

**Job No.** : GPEM2401000017EC  
**Test Report No.** : F690501-RF-EMC002248  
**Applicant** : AAMP of Florida, Inc dba AAMP Global  
**Product Name** : Dashcam  
**Model Name** : SDC-2CH2KQHD  
**Standards** : FCC Part 15 Subpart B, Class B  
**FCC ID** : XBDDCH3FG  
**Date of Receipt** : January 5, 2024  
**Date of Test** : March 15, 2024  
**Date of Issue** : March 27, 2024  
**Test Result** : Complied

- 1) This test report does not assure KOLAS accreditation.
- 2) The results of this test report are effective only to the items tested.
- 3) The SGS Korea is not responsible for the sampling, the results of this test report apply to the sample as received.

	Tested by (Name, signature)	Approved by (Name, signature)
Affirmation	DoHyeon Lee 	Paul Kang 

## SGS Korea Co., Ltd. Gunpo Laboratory

4, LS-ro 182beon-gil, Gunpo-si, Gyeonggi-do, 15807, KOREA

**Remarks :**

This document is issued by the Company subject to its General Conditions of Service printed overleaf, available on request or accessible at <http://www.sgs.com/en/Terms-and-Conditions.aspx> and, for electronic format documents, subject to Terms and Conditions for Electronic Documents at [www.sgs.com/terms\\_e-document.htm](http://www.sgs.com/terms_e-document.htm).

The results shown in this test report refer only to the sample(s) tested unless otherwise stated. This Test Report cannot be reproduced, except in full.

# Contents

1. <i>Test Laboratory</i> .....	4
1.1 General information.....	4
2. <i>General Information of E.U.T.</i> .....	5
2.1 Applicant Information .....	5
2.2 General Information of E.U.T. ....	5
2.3 Configurations of E.U.T .....	5
3. <i>E.U.T. Operation and Test Configuration</i> .....	6
3.1 Peripheral Equipments .....	6
3.2 Cable List.....	6
3.3 Operating Modes and Conditions .....	6
3.4 Test System Layout .....	6
3.5 Modifications to the test items during testing .....	7
4. <i>Test Results</i> .....	8
4.1 Summary .....	8
4.2 Note .....	8
5. <i>Emission Test</i> .....	9
5.1 Test Method and Limits .....	9
5.2 Test Limits.....	9
5.3 <i>Radiated Emission</i> .....	10
5.3.1 Test Equipments .....	10
5.3.2 Environment Conditions .....	10
5.3.3 Test Result.....	11
<i>Appendix A: Measurement Uncertainty</i> .....	15

## ***Revision History***

<b>Revision</b>	<b>Report Number</b>	<b>Description</b>
0	F690501-RF-EMC002248	Initial

---

## 1. Test Laboratory

### 1.1 General information

Name	SGS Korea Co., Ltd.	
- Branch Site	4, LS-ro 182beon-gil, Gunposi, Gyeonggi-do, Republic of Korea Tel. 82 31 428 5700 Fax. 82 31 427 5370	
- Branch Site-3	35, Giheungdanji-ro 121beon-gil, Giheung-gu, Yongin-si, Gyeonggi-do, Republic of Korea Tel. 82 31 548 0710 Fax. 82 31 548 0719	
- Branch Site-4	12, Dongtansandan 10-gil, Hwaseong-si, Gyeonggi-do, 18487, Republic of Korea Tel. 82 31 8007 5302 Fax. 82 31 427 2370	
Website	<a href="http://www.sgsgroup.kr/ee">http://www.sgsgroup.kr/ee</a>	

SGS Korea Co., Ltd. has been accredited by the agencies listed in the following table;

Accreditation	Accreditation bodies	Accreditation No.
KC	MSIT- RRA	
FCC	FCC (MRA)	KR0150
IC	IC (MRA)	
Vietnam-MIC	Vietnam-MIC	
Japan EMI	VCCI	C-14102, T-11153, R-13662, G-20037
KOLAS	KATS - KOLAS	Testing No.123
CBTL	IECEE	TL 146
SDPPI	SDPPI	-

## 2. General Information of E.U.T.

### 2.1 Applicant Information

Applicant	AAMP of Florida, Inc dba AAMP Global
Applicant Address	15500 Lightwave Dr , Ste 202 Clearwater, FL 33760, USA
Manufacturer	BG T&A Co.
Manufacturer Address	L&C TOWER 5,6F, 153-18, LS-ro, Gunpo-si, Gyeonggi-do, Republic of Korea

### 2.2 General Information of E.U.T.

Classification	Description
Product Name	Dashcam
Model Name	SDC-2CH2KQHD
Alt. Model Name	DC-H3-FG
Model Differences	Basic model and alternative model are the same, only the seller (packaging, accessories) is different.
Serial No.	-
EMI Classification	Class B
Internal Clock Frequency	24 MHz (Wi-Fi Frequency : 2 412 ~ 2 472 MHz)
Rated Power	12 ~ 24 Vd.c.
Tested Power	12 Vd.c., 24 Vd.c.
H/W Version	Revision A.
S/W Version	Revision 1.4
Port	2CH Input Port (for Rear Dash Cam), 2CH Input Port (for Front Dash Cam), DC IN Power Port, Memory Card Slot
Components	Main (Front) Dash Cam, Front Dash Cam Bracket with Adhesive, Rear Dash Cam with Adhesive, Hardwire Harness, Cigarette Lighter Adapter Harness, microSD Card
Function	Dash Cam

### 2.3 Configurations of E.U.T

Description	Model	Serial No.	Manufacturer	Note
Main Board	DC-H3-FG(REV.E)	-	-	-
Rear Dash cam Board	DC-H3-FG-REAR(REV.C)	-	-	-
GPS Board	DC-H3-FG-GPS(REV.D)	-	-	-
microSD Card	-	-	-	-
Cigar jack	-	-	-	-

### 3. E.U.T. Operation and Test Configuration

#### 3.1 Peripheral Equipments

Description	Model	Serial No.	Manufacturer	Note.
Car Battery	-	-	-	-
Mobile Phone	SM-S911N	R3CW2062SRH	SAMSUNG	-

#### 3.2 Cable List

Name	Start		END		Cable Spec.		Used core
	I/O Port	Name	I/O Port	Name	Length (m)	Shield	
EUT (Front Dash cam)	DC IN	EUT (Cigar jack)	DC OUT		4.0	Unshield	-
	2CH Input Port (for rear camera)	EUT (Rear Dash cam)	2CH Input Port (for front camera)		7.0	Unshield	-
	-	Mobile Phone	-		-	-	-
	-	RF STATION	-		-	-	-
EUT (Cigar jack)	DC IN	Car Battery	DC OUT		1.0	Unshield	-

#### 3.3 Operating Modes and Conditions

Operating mode	Operating condition
01 WLAN 2.412 GHz +GNSS(GPS)+Dash Cam	GPS signal receiving status and Front & Rear Dash Cam View Test and Communication status with Mobile Phone

#### 3.4 Test System Layout

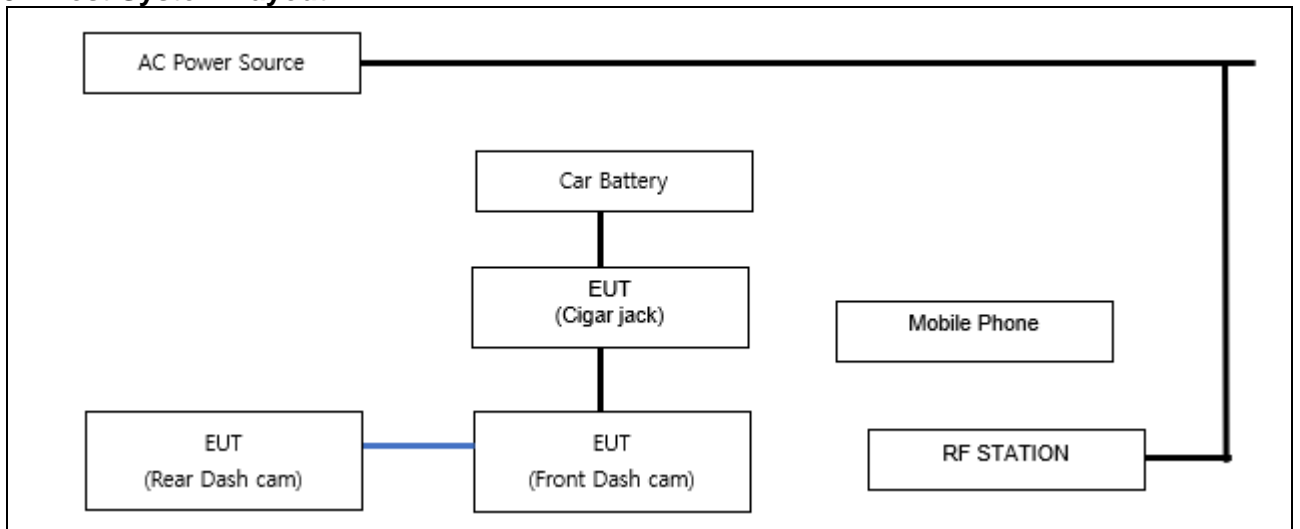

**3.5 Modifications to the test items during testing**

---

- No modifications done during testing
  - Modification done during testing (see details below)
- 

No.	Description of modification (if any)
1	
2	

---

## 4. Test Results

### 4.1 Summary

Test Items	Standards	Test Results
Conducted Emission	FCC Part 15 Subpart B Section 15.107 ANSI C63.4a:2017	N/A
Radiated Emission	FCC Part 15 Subpart B Section 15.109 ANSI C63.4a:2017	Complied

### 4.2 Note

- 1 Test Methods of all test items are performed according to the basic standard in subclause 4.1.
- 2



# Emission Test

## 5.1 Test Method and Limits

Test Items	Measuring Frequency Range	RBW	Measuring Distance
Conducted Emission	0.15 MHz - 30 MHz	9 kHz	-
Radiated Emission	30 MHz - 1 GHz	120 kHz	10 m or 3 m
	Above 1 GHz	1 MHz	3 m

## 5.2 Test Limits

Frequency Range	Limits(dB $\mu$ V)		Class
	Quasi-peak	CISPR-Average	
0.15 MHz - 0.5 MHz	79	66	Class A
0.5 MHz - 30 MHz	73	60	
0.15 MHz - 0.5 MHz	66 to 56 <sup>Note1</sup>	56 to 46 <sup>Note1</sup>	Class B
0.5 MHz - 5 MHz	56	46	
5 MHz - 30 MHz	60	50	

[Table 2.1 Conducted Emission Limits]

Frequency Range	Limits(dB $\mu$ V/m)		Class
	Quasi-peak		
30 MHz - 88 MHz	39.0		Class A (10 m method)
88 MHz - 216 MHz	43.5		
216 MHz - 960 MHz	46.4		
960 MHz - 1 GHz	49.5		Class B (3 m method)
30 MHz - 88 MHz	40.0		
88 MHz - 216 MHz	43.5		
216 MHz - 960 MHz	46.0		
960 MHz - 1 GHz	54.0		

[Table 2.2 Radiated Emission Limits below 1 GHz\_ For FCC Part 15 Subpart B]

Frequency Range	Limits(dB $\mu$ V)		Class
	Quasi-peak	CISPR-Average	
Above 1 GHz	79.5	59.5	Class A
	74.0	54.0	Class B

[Table 2.3 Radiated Emission Limits Above 1 GHz\_ For FCC Part 15 Subpart B <sup>Note2</sup>]

Note 1. The lower limit shall apply at the transition frequencies. The limit decreases linearly with the logarithm of that frequency.  
 Note 2. The limits of class A equipment is extrapolated using an extrapolation factor of 20 dB/decade because it was measured at 3 m distance not 10 m distance.

### 5.3 Radiated Emission

#### 5.3.1 Test Equipments

Equipment	Model	Manufacturer	Serial No	Cal Due. Date
EMI TEST RECEIVER	ESU40	R&S	100075	2025-01-17
Hybrid ANTENNA	VULB 9163	SCHWARZBECK	9163-396	2024-03-22
Double Ridged Horn Antenna	HF907	R&S	100208	2025-03-04
PREAMPLIFIER	AM-1431	MITEQ	1336160	2024-05-23
AMPLIFIER	SCU 18	R&S	10070	2024-08-23

Note. Measuring software is below

- Branch Site : ELECTRA(V5.01.0) from R&S
- Branch Site-3 : EMC32(V10.40.10) from R&S
- Branch Site-4 : EMC32(V10.40.10) from R&S

#### 5.3.2 Environment Conditions

Test Site	10 m SEMI-ANECHOIC CHAMBER in Branch site-3
Temperature	(Minimum 20.8, Maximum 21.5) °C
Humidity	(Minimum 31.0, Maximum 32.0) % R.H.
Atmospheric Pressure	(Minimum 101.0, Maximum 101.0) kPa
Test Date	2024-03-15

### 5.3.3 Test Result

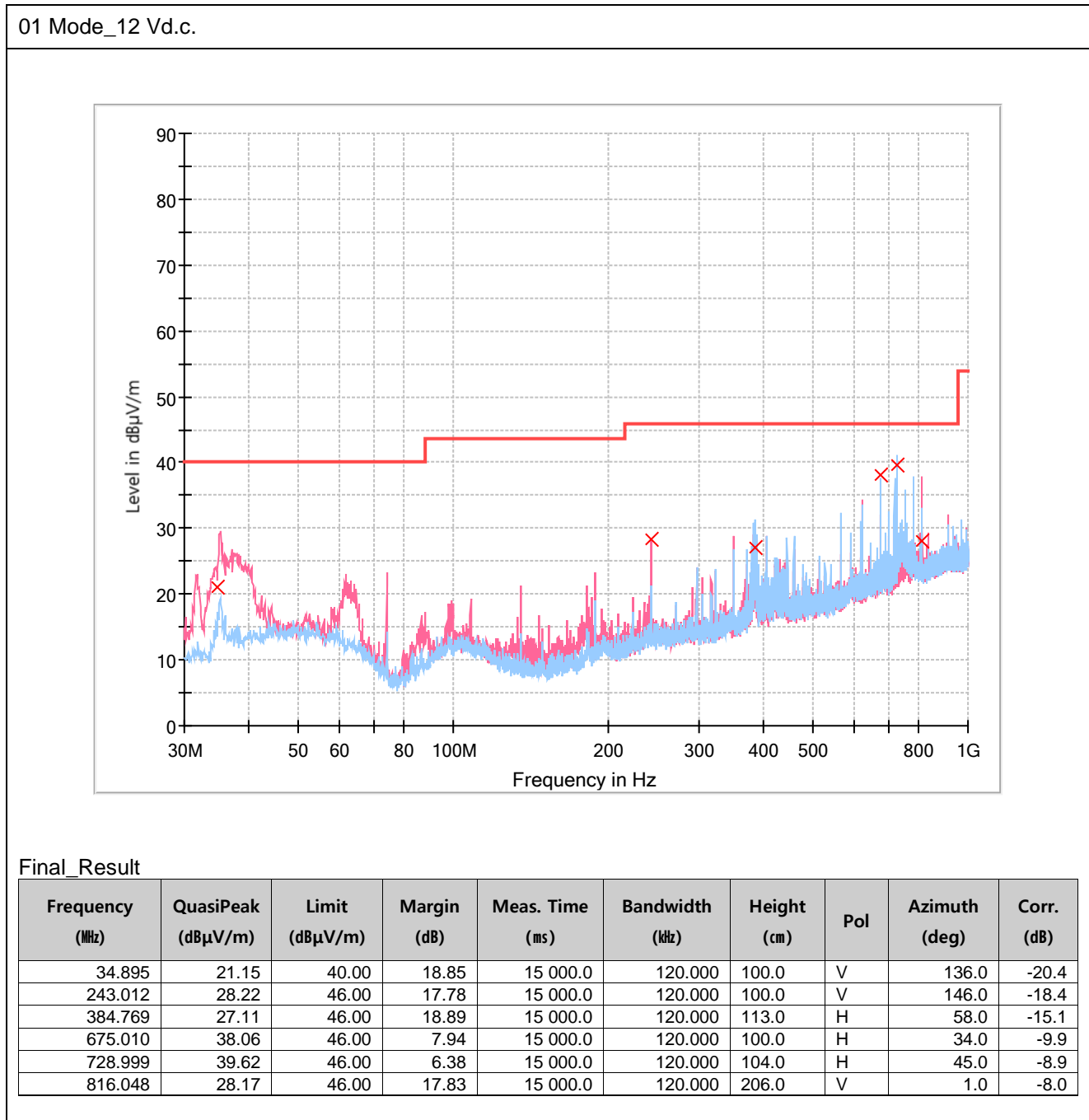

01 Mode\_24 Vd.c.

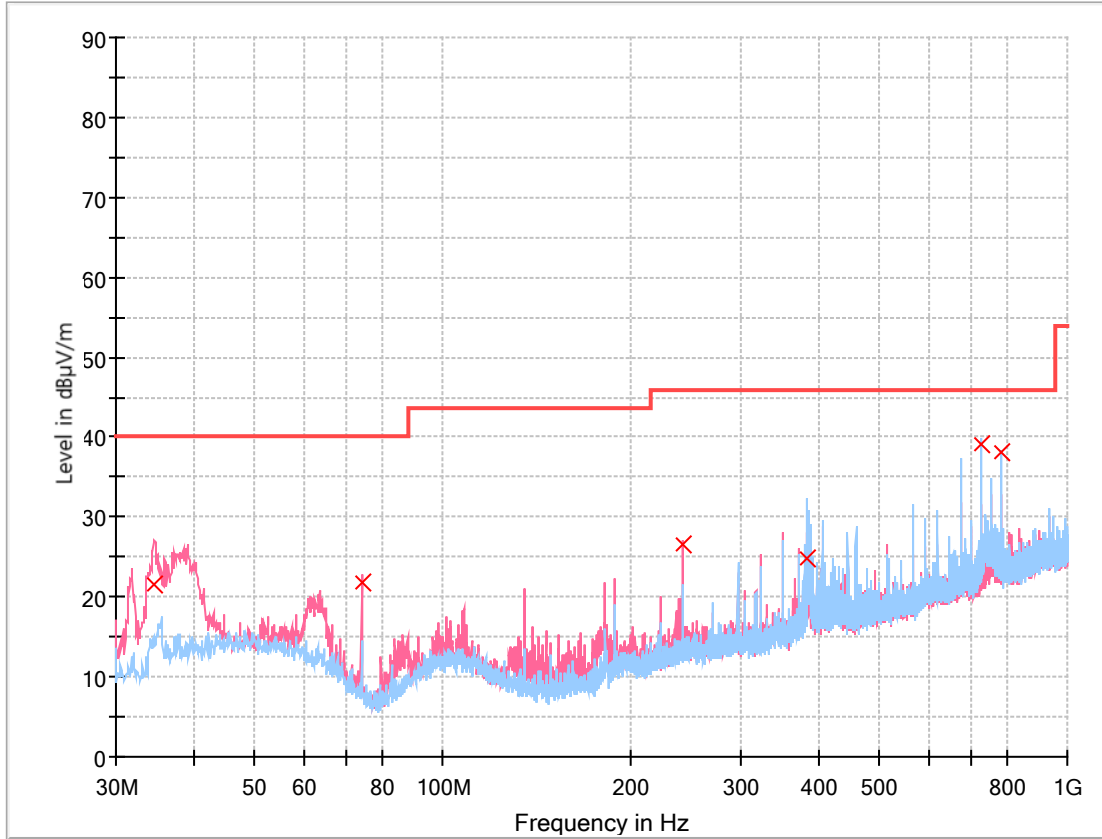

Final\_Result

Frequency (MHz)	QuasiPeak (dBµV/m)	Limit (dBµV/m)	Margin (dB)	Meas. Time (ms)	Bandwidth (kHz)	Height (cm)	Pol	Azimuth (deg)	Corr. (dB)
34.559	21.67	40.00	18.33	15 000.0	120.000	106.0	V	275.0	-20.6
74.272	21.84	40.00	18.16	15 000.0	120.000	155.0	V	59.0	-23.7
243.012	26.63	46.00	19.37	15 000.0	120.000	100.0	V	8.0	-18.4
382.423	24.94	46.00	21.06	15 000.0	120.000	125.0	H	62.0	-15.1
728.999	39.20	46.00	6.80	15 000.0	120.000	103.0	H	49.0	-8.9
783.028	38.15	46.00	7.85	15 000.0	120.000	104.0	H	196.0	-8.4

Note. Measurement Uncertainty: See Appendix A

- POL H = Horizontal
- POL V = Vertical
- Margin = Limit – Quasi Peak
- Corr. = Antenna Factor + Cable loss – Amplifier Gain

01 Mode\_12 Vd.c.

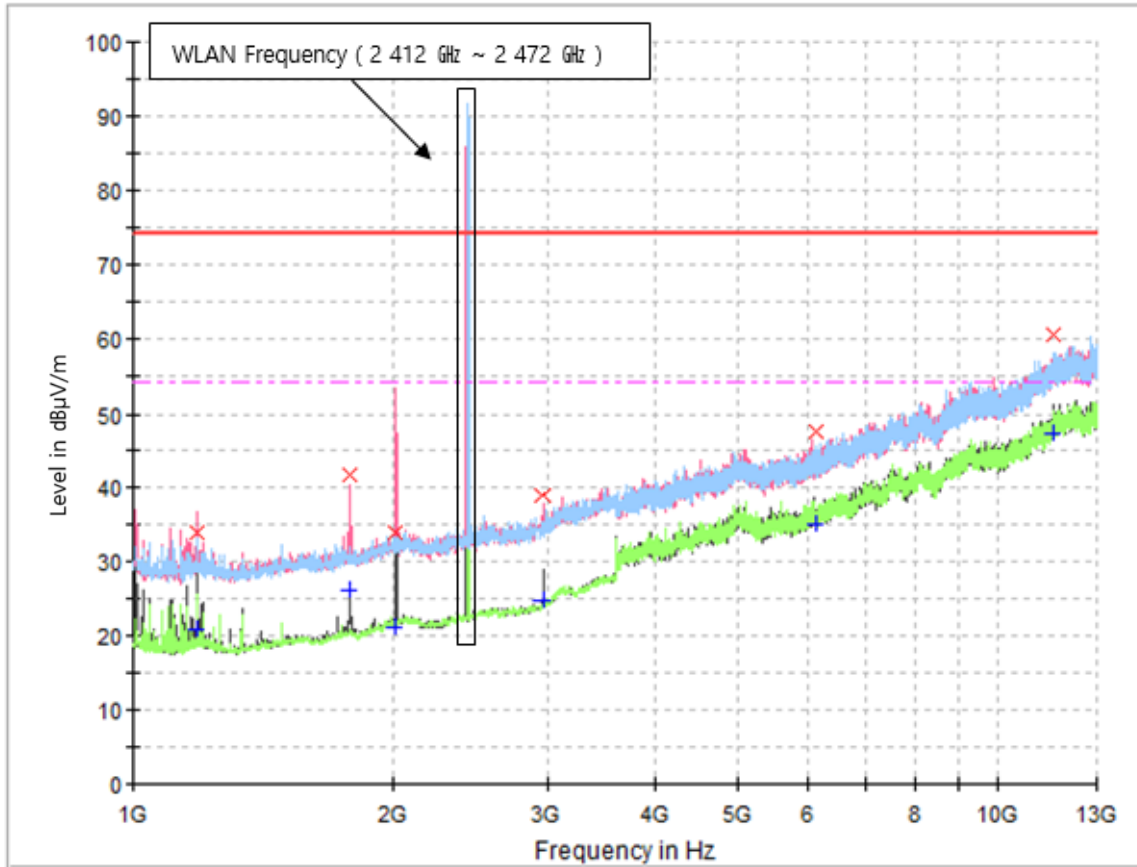

Final\_Result

Frequency (MHz)	MaxPeak (dBµV/m)	CAverage (dBµV/m)	Limit (dBµV/m)	Margin (dB)	Meas. Time(ms)	Bandwidth (kHz)	Height (cm)	Pol	Azimuth (deg)	Corr. (dB)
1 187.200	---	21.01	54.00	32.99	15 000.0	1 000.000	100.0	V	356.0	-14.6
1 187.200	33.94	---	74.00	40.06	15 000.0	1 000.000	100.0	V	356.0	-14.6
1 781.200	41.89	---	74.00	32.11	15 000.0	1 000.000	100.0	V	356.0	-11.0
1 781.200	---	26.12	54.00	27.88	15 000.0	1 000.000	100.0	V	356.0	-11.0
2 015.200	---	21.27	54.00	32.73	15 000.0	1 000.000	100.0	V	64.0	-8.6
2 015.200	33.98	---	74.00	40.02	15 000.0	1 000.000	100.0	V	64.0	-8.6
2 970.400	---	24.86	54.00	29.14	15 000.0	1 000.000	100.0	V	0.0	-4.8
2 970.400	38.92	---	74.00	35.08	15 000.0	1 000.000	100.0	V	0.0	-4.8
6 158.800	---	35.23	54.00	18.77	15 000.0	1 000.000	100.0	H	347.0	6.9
6 158.800	47.55	---	74.00	26.45	15 000.0	1 000.000	100.0	H	347.0	6.9
11 586.400	---	47.49	54.00	6.51	15 000.0	1 000.000	100.0	H	187.0	18.5
11 586.400	60.48	---	74.00	13.52	15 000.0	1 000.000	100.0	H	187.0	18.5

01 Mode\_24 Vd.c.

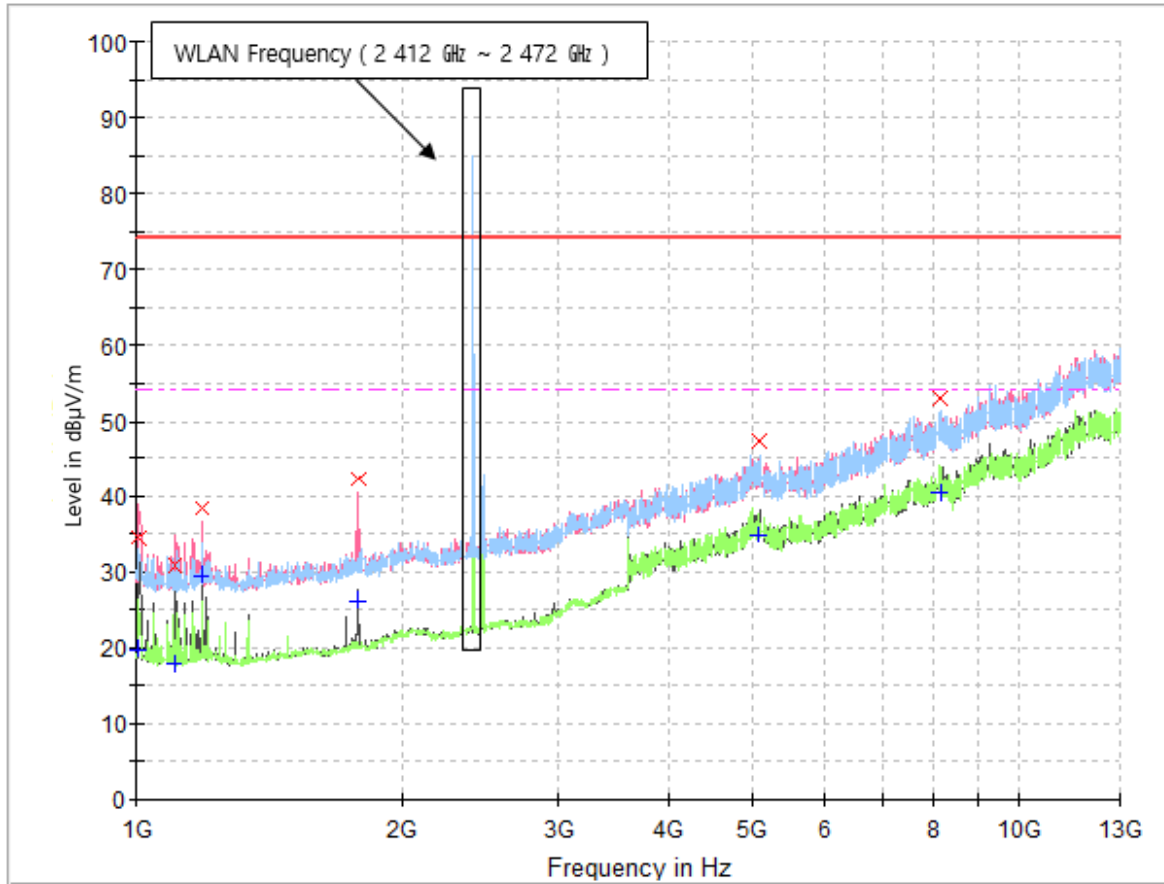

Final\_Result

Frequency (MHz)	MaxPeak (dBµV/m)	CAverage (dBµV/m)	Limit (dBµV/m)	Margin (dB)	Meas. Time(ms)	Bandwidth (kHz)	Height (cm)	Pol	Azimuth (deg)	Corr. (dB)
1 007.200	---	19.78	54.00	34.22	15 000.0	1 000.000	100.0	V	0.0	-14.4
1 007.200	34.48	---	74.00	39.52	15 000.0	1 000.000	100.0	V	0.0	-14.4
1 103.200	31.04	---	74.00	42.96	15 000.0	1 000.000	100.0	V	14.0	-14.4
1 103.200	---	17.86	54.00	36.14	15 000.0	1 000.000	100.0	V	14.0	-14.4
1 188.400	---	29.39	54.00	24.61	15 000.0	1 000.000	100.0	V	166.0	-14.6
1 188.400	38.32	---	74.00	35.68	15 000.0	1 000.000	100.0	V	166.0	-14.6
1 781.200	---	26.19	54.00	27.81	15 000.0	1 000.000	100.0	V	0.0	-11.0
1 781.200	42.45	---	74.00	31.55	15 000.0	1 000.000	100.0	V	0.0	-11.0
5 072.800	---	34.69	54.00	19.31	15 000.0	1 000.000	100.0	V	262.0	5.5
5 072.800	47.41	---	74.00	26.59	15 000.0	1 000.000	100.0	V	262.0	5.5
8 155.600	52.91	---	74.00	21.09	15 000.0	1 000.000	100.0	V	54.0	11.4
8 155.600	---	40.26	54.00	13.74	15 000.0	1 000.000	100.0	V	54.0	11.4

Note. Measurement Uncertainty: See Appendix A

- AF = Antenna Factor
  - POL H = Horizontal
  - H = Height
  - Corr. = AF + CL - AMP
  - CL = Cable Loss
  - POL V = Vertical
  - Margin = Limit - Result
  - AMP = Amplifier Gain
  - A = Angle
- \*\* The value of 'Level' includes 'Corr.'.

Ex) In case

$$\text{Freq ; } 100 \text{ MHz, level ; } 30 \text{ dB}(\mu\text{V/m}), \text{ AF ; } 10 \text{ dB/m, CL ; } 4 \text{ dB, Amp ; } 25 \text{ dB}$$

$$\text{Result} = \text{Level} + \text{AF} + \text{CL} - \text{Amp} = 30 + 10 + 4 - 25 = 19$$

$$\text{Margin} = \text{Limit} - \text{Result} = 43.5 - 19 = 24.5$$

## Appendix A: Measurement Uncertainty

Test Method		Measurement Uncertainty	
Conducted Emission	ENV216	3.1 dB	(The confidential level is 95 %, $k=2$ )
	ESH2-Z5	2.8 dB	(The confidential level is 95 %, $k=2$ )
	ESH3-Z6	3.0 dB	(The confidential level is 95 %, $k=2$ )
Conducted Emission - Signal	ISN T800	5.3 dB	(The confidential level is 95 %, $k=2$ )
	ISNT8-Cat6	5.4 dB	(The confidential level is 95 %, $k=2$ )
	ISN S751	7.1 dB	(The confidential level is 95 %, $k=2$ )
Disturbance Voltage at Antenna Terminal		2.2 dB (The confidential level is 95 %, $k=2$ )	
Radiated Emission	9 kHz - 30 MHz	Horizontal	3.6 dB (The confidential level is 95 %, $k=2$ )
		Vertical	3.6 dB (The confidential level is 95 %, $k=2$ )
	30 MHz - 1 000 MHz	Horizontal	4.6 dB (The confidential level is 95 %, $k=2$ )
		Vertical	4.9 dB (The confidential level is 95 %, $k=2$ )
	1 GHz - 18 GHz	Horizontal	3.9 dB (The confidential level is 95 %, $k=2$ )
		Vertical	3.8 dB (The confidential level is 95 %, $k=2$ )

**Table A.1 Measurement Uncertainty of Branch Site**

Test Method		Measurement Uncertainty	
Conducted Emission	ENV216	3.2 dB	(The confidential level is 95 %, $k=2$ )
	ESH3-Z6	3.2 dB	(The confidential level is 95 %, $k=2$ )
	ESH2-Z5	3.0 dB	(The confidential level is 95 %, $k=2$ )
	NNLK8129	3.0 dB	(The confidential level is 95 %, $k=2$ )
Conducted Emission - Signal	ISN T800	5.5 dB	(The confidential level is 95 %, $k=2$ )
	ISN ST08	6.6 dB	(The confidential level is 95 %, $k=2$ )
Radiated Emission	9 kHz - 30 MHz	Horizontal	3.3 dB (The confidential level is 95 %, $k=2$ )
		Vertical	3.3 dB (The confidential level is 95 %, $k=2$ )
	30 MHz - 1 000 MHz	Horizontal	4.3 dB (The confidential level is 95 %, $k=2$ )
		Vertical	4.6 dB (The confidential level is 95 %, $k=2$ )
	1 GHz - 18 GHz	Horizontal	3.9 dB (The confidential level is 95 %, $k=2$ )
		Vertical	4.0 dB (The confidential level is 95 %, $k=2$ )

**Table A.2 Measurement Uncertainty of Branch Site-3**



Test Method		Measurement Uncertainty	
Conducted Emission	ENV216	3.5 dB (The confidential level is 95 %, $k=2$ )	
	ESH2-Z5	3.3 dB (The confidential level is 95 %, $k=2$ )	
	ESH3-Z6	3.3 dB (The confidential level is 95 %, $k=2$ )	
	NNLK8129	3.4 dB (The confidential level is 95 %, $k=2$ )	
Conducted Emission - Signal	ISN T800	5.7 dB (The confidential level is 95 %, $k=2$ )	
	ISN ST08	5.5 dB (The confidential level is 95 %, $k=2$ )	
Radiated Emission	9 kHz - 30 MHz (Triple Loop Ant.)	3.4 dB (The confidential level is 95 %, $k=2$ )	
	9 kHz - 30 MHz (Loop Ant.)	Horizontal	3.8 dB (The confidential level is 95 %, $k=2$ )
		Vertical	3.8 dB (The confidential level is 95 %, $k=2$ )
	30 MHz - 1 000 MHz	Horizontal	4.8 dB (The confidential level is 95 %, $k=2$ )
		Vertical	5.4 dB (The confidential level is 95 %, $k=2$ )
	1 GHz - 18 GHz	Horizontal	4.1 dB (The confidential level is 95 %, $k=2$ )
		Vertical	4.2 dB (The confidential level is 95 %, $k=2$ )

**Table A.3 Measurement Uncertainty of Branch Site-4**

- End of Test Report -