



Test Report No.: RF150319N004-10



FCC TEST REPORT (PART 90R)

Product: LTE Smartphone

Model Name: Smart-Ex 01

FCC ID: XAM500055GR04

Applicant: ecom instruments GmbH

Address: Industriestraße. 2, 97959 Assamstadt, Germany

Manufacturer: ecom instruments GmbH

Address: Industriestraße. 2, 97959 Assamstadt, Germany

Prepared by: Bureau Veritas Shenzhen Co., Ltd. Dongguan Branch

Lab Location: No. 34, Chenwulu Section, Guantai Rd., Houjie Town, Dongguan City, Guangdong 523942, China

TEL: +86 769 8593 5656

FAX: +86 769 8593 1080

E-MAIL: customerservice.dg@cn.bureauveritas.com

Report No.: RF150319N004-10

Received Date: Mar. 19, 2015

Test Date: Mar. 19, 2015 ~ Mar. 22, 2015

Issued Date: Mar. 23, 2015

This report should not be used by the client to claim product certification, approval, or endorsement by A2LA or any government agencies.

Any copying or replication of this report to or for any other person or entity, or use of our name or trademark, is permitted only with our prior written permission. This report sets forth our findings solely with respect to the test samples identified herein. The results set forth in this report are not indicative or representative of the quality or characteristics of the lot from which a test sample was taken or any similar or identical product unless specifically and expressly noted. Our report includes all of the tests requested by you and the results thereof based upon the information that you provided to us. You have 60 days from date of issuance of this report to notify us of any material error or omission caused by our negligence, provided, however, that such notice shall be in writing and shall specifically address the issue you wish to raise. A failure to raise such issue within the prescribed time shall constitute your unqualified acceptance of the completeness of this report, the tests conducted and the correctness of the report contents. Unless specific mention, the uncertainty of measurement has been explicitly taken into account to declare the compliance or non-compliance to the specification.



TABLE OF CONTENTS

RELEASE CONTROL RECORD	4
1 CERTIFICATION.....	5
2 SUMMARY OF TEST RESULTS.....	6
2.1 MEASUREMENT UNCERTAINTY	6
3 GENERAL INFORMATION	8
3.1 GENERAL DESCRIPTION OF EUT	8
3.2 CONFIGURATION OF SYSTEM UNDER TEST	9
3.3 DESCRIPTION OF SUPPORT UNITS.....	10
3.4 TEST ITEM AND TEST CONFIGURATION.....	10
3.5 GENERAL DESCRIPTION OF APPLIED STANDARDS	12
4 TEST TYPES AND RESULTS.....	13
4.1 OUTPUT POWER MEASUREMENT	13
4.1.1 LIMITS OF OUTPUT POWER MEASUREMENT.....	13
4.1.2 TEST PROCEDURES	14
4.1.3 TEST SETUP	15
4.1.4 EUT OPERATING CONDITIONS.....	15
4.1.5 TEST RESULTS	16
4.2 FREQUENCY STABILITY MEASUREMENT	18
4.2.1 LIMITS OF FREQUENCY STABILITY MEASUREMENT.....	18
4.2.2 TEST PROCEDURE.....	18
4.2.3 TEST SETUP.....	19
4.2.4 EUT OPERATING CONDITIONS.....	19
4.2.5 TEST RESULTS	20
4.3 OCCUPIED BANDWIDTH MEASUREMENT	21
4.3.1 LIMITS OF OCCUPIED BANDWIDTH MEASUREMENT	21
4.3.2 TEST SETUP.....	21
4.3.3 TEST PROCEDURES	21
4.3.4 EUT OPERATING CONDITIONS	21
4.4 EMISSION MASK MEASUREMENT	23
4.4.1 LIMITS OF EMISSION MASK MEASUREMENT	23
4.4.2 TEST PROCEDURES	23
4.4.3 TEST SETUP.....	23
4.4.4 EUT OPERATING CONDITIONS.....	23
4.4.5 TEST RESULTS	24
4.5 CONDUCTED SPURIOUS EMISSIONS.....	26
4.5.1 LIMITS OF CONDUCTED SPURIOUS EMISSIONS MEASUREMENT	26
4.5.2 TEST PROCEDURE.....	26
4.5.3 TEST SETUP.....	26
4.5.4 EUT OPERATING CONDITIONS	27
4.5.5 TEST RESULTS	27
4.6 RADIATED EMISSION MEASUREMENT	30
4.6.1 LIMITS OF RADIATED EMISSION MEASUREMENT	30
4.6.2 TEST INSTRUMENTS.....	30
4.6.3 TEST PROCEDURES	31
4.6.4 DEVIATION FROM TEST STANDARD	31
4.6.5 TEST SETUP.....	32



Test Report No.: RF150319N004-10



4.6.6	EUT OPERATING CONDITIONS	32
4.6.7	TEST RESULTS	33
5	INFORMATION ON THE TESTING LABORATORIES	37
6	APPENDIX A – MODIFICATIONS RECORDERS FOR ENGINEERING CHANGES TO THE EUT BY THE LAB	38



Test Report No.: RF150319N004-10

RELEASE CONTROL RECORD

ISSUE NO.	REASON FOR CHANGE	DATE ISSUED
RF150319N004-10	Original release	Mar. 23, 2015



Test Report No.: RF150319N004-10

1 CERTIFICATION

PRODUCT: LTE Smartphone
MODEL NAME: Smart-Ex 01
BRAND NAME: ecom MOBILE SAFETY /Sonim
APPLICANT: ecom instruments GmbH
TESTED DATE: Mar. 19, 2015 ~ Mar. 22, 2015
TEST SAMPLE: Identical Prototype
STANDARDS: **FCC Part 90 Subpart R**
FCC Part 2

The above equipment has been tested by **Bureau Veritas Shenzhen Co., Ltd. Dongguan Branch**, and found compliance with the requirement of the above standards. The test record, data evaluation & Equipment Under Test (EUT) configurations represented herein are true and accurate accounts of the measurements of the sample's EMC characteristics under the conditions specified in this report.

TESTED BY :  , **DATE :** Mar. 23, 2015
Glyn He/ Project Engineer

APPROVED BY :  , **DATE :** Mar. 23, 2015
Sam Tung / Technical Manager

2 SUMMARY OF TEST RESULTS

The EUT has been tested according to the following specifications:

STANDARD SECTION	TEST TYPE AND LIMIT	RESULT	REMARK
2.1046 90.542(a)(7)	Maximum Peak Output Power Limit	PASS	Meet the requirement of limit.
2.1055 90.539	Frequency Stability	PASS	Meet the requirement of limit.
2.1049	Occupied Bandwidth	PASS	Meet the requirement of limit.
90.210(b)	Emission Mask	PASS	Meet the requirement of limit.
2.1051 90.543(e)	Conducted Spurious Emissions	PASS	Meet the requirement of limit.
2.1051 90.543(e)(2)	Emission in the 769–775 MHz and 799–805 MHz band	PASS	Meet the requirement of limit.
2.1053 90.543(e)	Radiated Spurious Emissions	PASS	Meet the requirement of limit. Minimum passing margin is -45.81dB at 2379MHz.
2.1053 90.543(f)	Emissions in the band 1559–1610 MHz	PASS	Meet the requirement of limit. Minimum passing margin is -11.68dB at 1586MHz.

2.1 MEASUREMENT UNCERTAINTY

Where relevant, the following measurement uncertainty levels have been estimated for tests performed on the EUT as specified in CISPR 16-4-2:

MEASUREMENT	FREQUENCY	UNCERTAINTY
Conducted emissions	9kHz~30MHz	2.67dB
Radiated emissions	9KHz ~ 30MHz	2.74dB
	30MHz ~ 1GMHz	4.06dB
	1GHz ~ 18GHz	4.58dB
	18GHz ~ 40GHz	1.94dB

This uncertainty represents an expanded uncertainty expressed at approximately the 95% confidence level using a coverage factor of k=2.



2.2 TEST SITE AND INSTRUMENTS

Equipment	Manufacturer	Model No.	Serial No.	Last Cal.	Next Cal.
EMI Test Receiver	Rohde&Schwarz	ESU 26	100005	May 13,14	May 12,15
GPS Generator+ Antenna	TOJOIN	GNSS-5000A	E1-010119	Aug. 08, 14	Aug. 07, 15
Bilog Antenna	Teseq	CBL 6111D	30643	Jul. 25, 14	Jul. 24, 15
Horn Antenna (1GHz -18GHz)	ETS -Lindgren	3117	00062558	May 30, 14	May 29, 16
Amplifier (9kHz-1GHz)	SONOMA	310D	186955	Mar. 05,15	Mar. 04, 16
Pre-Amplifier (18GHz-40GHz)	EMCI	EMC 184045	980102	Nov. 20,14	Nov. 19,15
Pre-Amplifier (100MHz-26.5GHz)	Agilent	8449B	3008A00409	May 13,14	May 12,15
GPS Generator+ Antenna	TOJOIN	GNSS-5000A	E1-010119	Aug. 08, 14	Aug. 07, 15
3m Semi-anechoic Chamber	ETS-LINDGREN	9m*6m*6m	NSEMC003	Apr. 19,14	Apr. 18,15
Test Software	ADT	ADT_Radiated _V7.6.15.9.2	N/A	N/A	N/A
Spectrum Analyzer (9KHz-25GHz)	Agilent	E7405A	MY45118807	May 13,14	May 12,15
Power Meter	Anritsu	ML2495A	1139001	Feb. 20,15	Feb. 19,16
Power Sensor	Anritsu	MA2411B	1126068	Feb. 20,15	Feb. 19,16
Digital Multimeter	FLUKE	15B	A1220010DG	Oct. 29, 14	Oct. 28, 15
Humid & Temp Programmable Tester	Haida	HD-2257	110807201	Sep.04,14	Sep. 03,15
Oscilloscope	Agilent	DSO9254A	MY51260160	Oct. 17, 14	Oct. 16, 15
Signal Analyzer	Rohde & Schwarz	FSV7	102331	Nov. 05,14	Nov. 04,15
Signal Generator	Agilent	N5183A	MY50140980	Nov. 05,14	Nov. 04,15
ESG Vector Signal Generator	Agilent	E4438C	MY49072505	Mar.13, 15	Mar.12, 16
BLUETOOTH TESTER	Rohde&Schwarz	CBT32	100811	Sep. 04,14	Sep. 03,15

- NOTE:** 1. The calibration interval of the above test instruments is 12 months or 24 months and the calibrations are traceable to CEPREI/CHINA, GRGT/CHINA and NIM/CHINA.
2. The test was performed in Dongguan 966 Chamber.
3. The horn antenna are used only for the measurement of emission frequency above 1GHz if tested.
4. The FCC Site Registration No. is 502831.



3 GENERAL INFORMATION

3.1 GENERAL DESCRIPTION OF EUT

PRODUCT	LTE Smartphone	
MODEL NAME	Smart-Ex 01	
TYPE NUMBER	L16V012AB	
POWER SUPPLY	5.0Vdc (adapter or host equipment) 3.7Vdc (Li-ion battery)	
MODULATION TECHNOLOGY	LTE Band 14, QPSK, 16QAM	
FREQUENCY RANGE	LTE Band 14 (Channel Bandwidth: 5MHz)	790.5MHz ~ 795.5MHz
	LTE Band 14 (Channel Bandwidth: 10MHz)	793MHz
EMISSION DESIGNATOR	LTE Band 14 (Channel Bandwidth: 5MHz)	4M49G7D
	LTE Band 14 (Channel Bandwidth: 10MHz)	8M91W7D
MAX. ERP POWER	LTE Band 14 (Channel Bandwidth: 5MHz)	250mW
	LTE Band 14 (Channel Bandwidth: 10MHz)	241mW
ANTENNA TYPE	Fixed Internal antenna with -1dBi gain	
DATA CABLE	See note 3	
I/O PORTS	Refer to user's manual	

NOTE:

- For a more detailed features description, please refer to the manufacturer's specifications or the user's manual.
- The EUT was powered by the following adapters:

ADAPTER 1	
BRAND:	Sonim
MODEL:	S11C02
INPUT:	AC 100-240V, 450mA
OUTPUT:	DC 5V, 2100mA

- The EUT matched the following USB cable:

USB CABLE	
BRAND:	ecom MOBILE SAFETY
MODEL:	Safety Box SB S01
SIGNAL LINE:	1.1 METER

- For the test results, the EUT had been tested with all conditions. But only the worst case was shown in test report.

3.2 CONFIGURATION OF SYSTEM UNDER TEST

FOR RADIATION EMISSION TEST

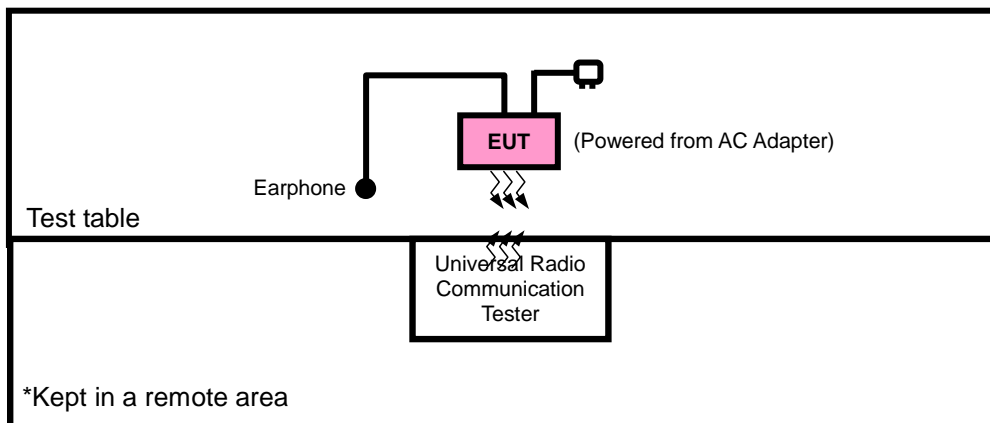

FOR E.I.R.P TEST

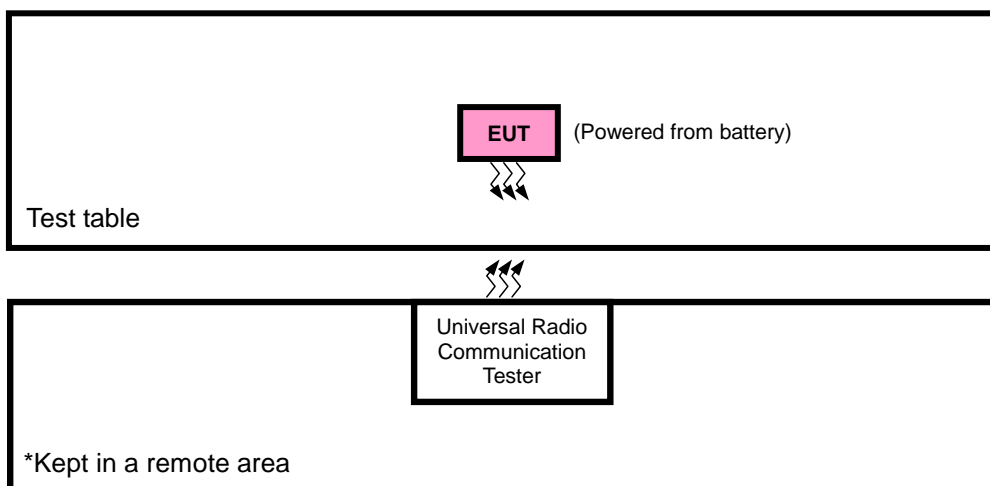



3.3 DESCRIPTION OF SUPPORT UNITS

The EUT has been tested as an independent unit together with other necessary accessories or support units. The following support units or accessories were used to form a representative test configuration during the tests.

NO.	PRODUCT	BRAND	MODEL NO.	SERIAL NO.	FCC ID
1	DC source	LONG WEI	PS-6403D	010934269	N/A
2	PC	HP	A6608CN	3CR83825X3	N/A
3	Earphone	Minami	ME-816B5-E	N/A	N/A

NO.	SIGNAL CABLE DESCRIPTION OF THE ABOVE SUPPORT UNITS
1	DC Line: Unshielded, Detachable 1.0m
2	AC Line: Unshielded, Detachable 1.5m
3	DC Line: Unshielded, Detachable 1.2m

NOTE: All power cords of the above support units are non shielded (1.8m).

3.4 TEST ITEM AND TEST CONFIGURATION

Pre-Scan has been conducted to determine the worst-case mode from all possible combinations between available modulations, data rates, XYZ axis and antenna ports. The worst case was found when positioned on Y-plane for EIRP and X-axis for radiated emission. Following channel(s) was (were) selected for the final test as listed below:

EUT CONFIGURE MODE	DESCRIPTION
A	EUT + Adapter + Earphone with LTE link
B	EUT + Battery + Earphone with LTE link



**BUREAU
VERITAS**

Test Report No.: RF150319N004-10

LTE BAND 14 MODE

EUT CONFIGURE MODE	TEST ITEM	AVAILABLE CHANNEL	TESTED CHANNEL	CHANNEL BANDWIDTH	MODULATION	MODE
-	OUTPUT POWER	23305 to 23355	23305, 23330, 23355	5MHz	QPSK, 16QAM	1 RB / 0 RB Offset
		23330	23330	10MHz	QPSK, 16QAM	1 RB / 0 RB Offset
	E.R.P.	23305 to 23355	23305, 23330, 23355	5MHz	QPSK, 16QAM	1 RB / 0 RB Offset
		23330	23330	10MHz	QPSK, 16QAM	1 RB / 0 RB Offset
-	FREQUENCY STABILITY	23305 to 23355	23330	5MHz	QPSK	1 RB / 12 RB Offset
		23330	23330	10MHz	QPSK	1 RB / 49 RB Offset
-	OCCUPIED BANDWIDTH	23305 to 23355	23305, 23330, 23355	5MHz	QPSK, 16QAM	25 RB / 0 RB Offset
		23330	23330	10MHz	QPSK, 16QAM	50 RB / 0 RB Offset
-	MASK	23305 to 23355	23305, 23330, 23355	5MHz	QPSK, 16QAM	25 RB / 0 RB offset
		23330	23330	10MHz	QPSK, 16QAM	50 RB / 0 RB offset
-	OUT-OF-BAND EMISSION	23305 to 23355	23305	5MHz	QPSK, 16QAM	1 RB / 0 RB Offset 25 RB / 0 RB Offset
			23330	5MHz	QPSK, 16QAM	25 RB / 0 RB Offset
			23355	5MHz	QPSK, 16QAM	1 RB / 24 RB Offset 25 RB / 0 RB Offset
		23330	23330	10MHz	QPSK, 16QAM	1 RB / 0 RB Offset 1 RB / 49 RB Offset 50 RB / 0 RB Offset
-	CONDCUDED EMISSION	23305 to 23355	23330	5MHz	QPSK	1 RB / 0 RB Offset
		23330	23330	10MHz	QPSK	1 RB / 0 RB Offset
-	RADIATED EMISSION	23305 to 23355	23330	5MHz	QPSK	1 RB / 0 RB Offset
		23330	23330	10MHz	QPSK	1 RB / 0 RB Offset

Note: This device was tested under all bandwidths, RB configurations and modulations. The worst case was found in QPSK modulation.

TEST CONDITION:

TEST ITEM	ENVIRONMENTAL CONDITIONS	INPUT POWER	TESTED BY
EIRP	24deg. C, 60%RH	3.7Vdc from Battery	Blue Zheng
FREQUENCY STABILITY	24deg. C, 61%RH	3.7Vdc from Battery	Yuqiang Yin
OCCUPIED BANDWIDTH	24deg. C, 61%RH	3.7Vdc from Battery	Yuqiang Yin
PEAK TO AVERAGE RATIO	24deg. C, 61%RH	3.7Vdc from Battery	Yuqiang Yin
BAND EDGE	24deg. C, 61%RH	3.7Vdc from Battery	Yuqiang Yin
CONDCUDED EMISSION	24deg. C, 61%RH	3.7Vdc from Battery	Yuqiang Yin
RADIATED EMISSION	24deg. C, 60%RH	5Vdc from adapter	Blue Zheng



Test Report No.: RF150319N004-10

3.5 GENERAL DESCRIPTION OF APPLIED STANDARDS

The EUT is a RF product. According to the specifications of the manufacturer, it must comply with the requirements of the following standards:

FCC 47 CFR Part 2

FCC 47 CFR Part 90

ANSI/TIA/EIA-603-C 2004

NOTE: All test items have been performed and recorded as per the above standards.



Test Report No.: RF150319N004-10

4 TEST TYPES AND RESULTS

4.1 OUTPUT POWER MEASUREMENT

4.1.1 LIMITS OF OUTPUT POWER MEASUREMENT

Per FCC Part 90.542(a)(6)(7),

Control stations and mobile stations transmitting in the 793–798 MHz band are limited to 30 watts E.R.P.

Portable stations (hand-held devices) transmitting in the 793–798 MHz band are limited to 3 watts E.R.P.



4.1.2 TEST PROCEDURES

ERP MEASUREMENT:

- a. The EUT was set up for the maximum power with LTE link data modulation. The power was measured with Agilent Spectrum Analyzer. All measurements were done at 1 channel. RWB and VBW is 5MHz for LTE
- b. E.I.R.P power measurement. In the semi-anechoic chamber, EUT placed on the 0.8m height of Turn Table, rotated the table around 360 degrees to search the maximum radiation power and receiver antenna shall be rotated vertical and horizontal polarization and moved height from 1m to 4m to find the maximum polar radiated power. The “Read Value” is the spectrum reading the maximum power value.
- c. The substitution horn antenna is substituted for EUT at the same position and signals generator export the CW signal to the substitution antenna via a TX cable. Rotated the Turn Table and moved receiving antenna to find the maximum radiation power. Adjust output power level of S.G to get a Value of spectrum reading equal to “Read Value” of step a. Record the power level of S.G
- d. EIRP = Output power level of S.G – TX cable loss + Antenna gain of substitution horn
- e. E.R.P = E.I.R.P- 2.15 dB

CONDUCTED POWER MEASUREMENT:

The EUT was set up for the maximum power with CDMA & LTE link data modulation and link up with simulator. Set the EUT to transmit under low, middle and high channel and record the power level shown on simulator.



4.1.3 TEST SETUP

ERP MEASUREMENT:

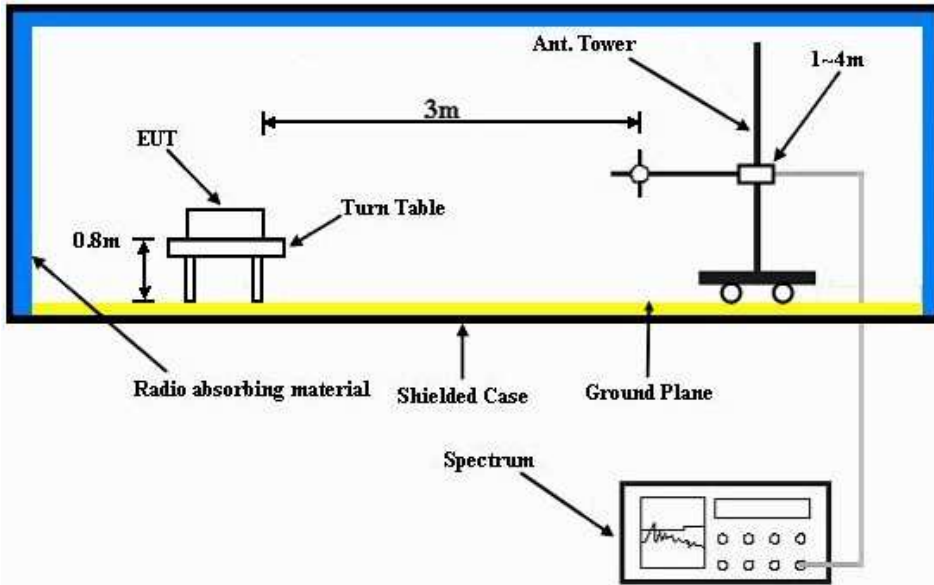

For the actual test configuration, please refer to the attached file (Test Setup Photo).

CONDUCTED POWER MEASUREMENT:

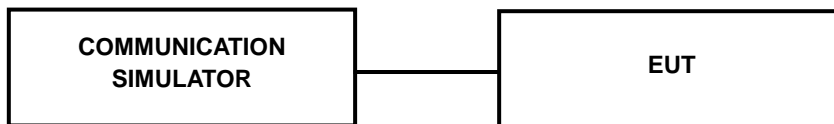

4.1.4 EUT OPERATING CONDITIONS

- 1) Upload test waveform to signal generator and produce test signal to link up with EUT.
- 2) Execute test tool to control EUT transmit at specific modulation, RB size, frequency and output power level continuously.

Note: Test waveform and tool are provided by client.



**BUREAU
VERITAS**

Test Report No.: RF150319N004-10

4.1.5 TEST RESULTS

CONDUCTED OUTPUT POWER (dBm)

Band / BW	Modulation	RB Size	RB Offset	Low CHG 23305	Mid CH 23330	High CH 23355	3GPP MPR (dB)
				Frequency 790.5 MHz	Frequency 793 MHz	Frequency 795.5 MHz	
14/5	QPSK	1	0	22.74	22.76	22.74	0
		1	12	22.65	22.69	22.68	0
		1	24	22.6	22.65	22.62	0
		12	0	21.7	21.71	21.66	1
		12	6	21.64	21.7	21.63	1
		12	13	21.58	21.63	21.5	1
		25	0	21.6	21.68	21.65	1
	16QAM	1	0	21.75	21.78	21.74	1
		1	12	21.7	21.71	21.66	1
		1	24	21.66	21.67	21.59	1
		12	0	20.72	20.73	20.72	2
		12	6	20.7	20.72	20.7	2
		12	13	20.64	20.65	20.61	2
		25	0	20.69	20.7	20.63	2

Band / BW	Modulation	RB Size	RB Offset	Mid CH 23330	3GPP MPR (dB)
				Frequency 793 MHz	
14/10	QPSK	1	0	22.78	0
		1	24	22.71	0
		1	49	22.67	0
		25	0	21.73	1
		25	12	21.72	1
		25	25	21.65	1
		50	0	21.7	1
	16QAM	1	0	21.8	1
		1	24	21.73	1
		1	49	21.69	1
		25	0	20.75	2
		25	12	20.74	2
		25	25	20.67	2
		50	0	20.72	2



BUREAU
VERITAS

Test Report No.: RF150319N004-10

ERP POWER (dBm)

LTE Band 14							
Channel Bandwidth: 5MHz / QPSK							
Plane	Channel	Frequency (MHz)	LVL (dBm)	Correction Factor(dB)	ERP(dBm)	ERP(mW)	Polarization (H/V)
Z	23305	790.5	-8.96	35.09	23.98	250.03	H
	23330	793.0	-8.69	34.43	23.59	228.56	H
	23355	795.5	-8.55	34.61	23.91	246.04	H
	23305	790.5	-13.46	35.9	20.29	106.91	V
	23330	793.0	-13.86	35.61	19.60	91.20	V
	23355	795.5	-13.55	35.47	19.77	94.84	V

LTE Band 14							
Channel Bandwidth: 5MHz / 16QAM							
Plane	Channel	Frequency (MHz)	LVL (dBm)	Correction Factor(dB)	ERP(dBm)	ERP(mW)	Polarization (H/V)
Z	23305	790.5	-8.96	35.09	23.98	250.03	H
	23330	793.0	-8.66	34.43	23.62	230.14	H
	23355	795.5	-8.65	34.61	23.81	240.44	H
	23305	790.5	-13.57	35.9	20.18	104.23	V
	23330	793.0	-13.48	35.61	19.98	99.54	V
	23355	795.5	-13.76	35.47	19.56	90.36	V

LTE Band 14							
Channel Bandwidth: 10MHz / QPSK							
Plane	Channel	Frequency (MHz)	LVL (dBm)	Correction Factor(dB)	ERP(dBm)	ERP(mW)	Polarization (H/V)
Z	23330	793.0	-8.46	34.43	23.82	240.99	H
	23330	793.0	-13.54	35.61	19.92	98.17	V

LTE Band 14							
Channel Bandwidth: 10MHz / 16QAM							
Plane	Channel	Frequency (MHz)	LVL (dBm)	Correction Factor(dB)	ERP(dBm)	ERP(mW)	Polarization (H/V)
Z	23330	793.0	-8.97	34.43	23.31	214.29	H
	23330	793.0	-13.75	35.61	19.71	93.54	V

Bureau Veritas Shenzhen Co., Ltd.
Dongguan Branch

No. 34, Chenwulu Section, Guantai Rd.,
Houjie Town, Dongguan City,
Guangdong 523942, China

Tel: +86 769 8593 5656
Fax: +86 769 8593 1080
Email: customerservice.dg@cn.bureauveritas.com



4.2 FREQUENCY STABILITY MEASUREMENT

4.2.1 LIMITS OF FREQUENCY STABILITY MEASUREMENT

The frequency stability of mobile, portable and control transmitters operating in the wideband segment must be 1.25 parts per million or better when AFC is locked to a base station, and 5 parts per million or better when AFC is not locked.

4.2.2 TEST PROCEDURE

- a. The oven room could control the temperatures and humidity.
- b. Power must be removed when changing from one temperature to another or one voltage to another voltage. Power warm up is at least 15 min and power applied should perform before recording frequency error.
- c. Laptop pc is connected the external power supply to control the DC input power. The various Volts from the minimum to maximum working voltage. Each step shall be record the frequency error rate.
- d. The temperature range step is 10 degrees in this test items. All temperature levels shall be hold the $\pm 0.5^{\circ}\text{C}$ during the measurement testing.
- e. The each temperature step shall be at least 0.5 hours, consider the EUT could be test under the stability condition.

NOTE: The frequency error was recorded frequency error from the communication simulator.

4.2.3 TEST SETUP

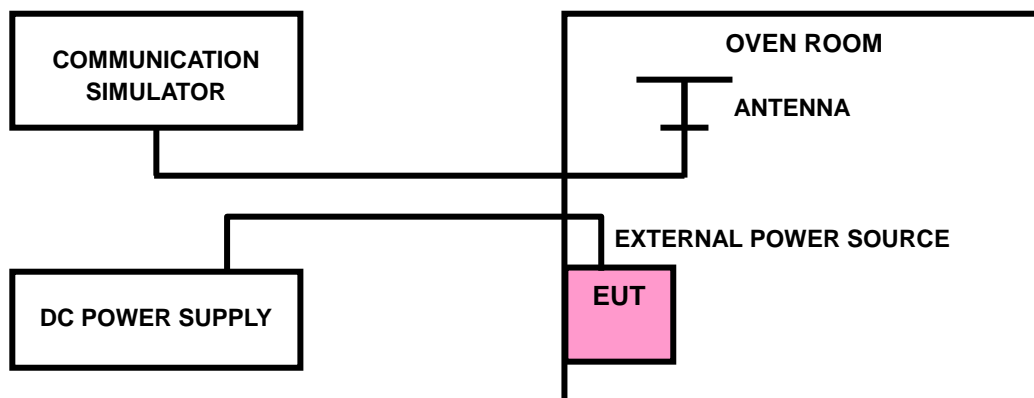

4.2.4 EUT OPERATING CONDITIONS

Same as 4.1.4.



4.2.5 TEST RESULTS

FREQUENCY ERROR vs. VOLTAGE

VOLTAGE (Volts)	FREQUENCY ERROR (ppm)		LIMIT (ppm)
	LTE Band 14		
	5MHz	10MHz	
3.8	0.0006	0.0014	1.25
3.5	-0.0079	-0.0082	1.25
4.35	0.0100	0.0074	1.25

NOTE: The applicant defined the normal working voltage of the battery is from 3.5Vdc to 4.35Vdc.

FREQUENCY ERROR vs. TEMPERATURE

TEMP. (°C)	FREQUENCY ERROR (ppm)		LIMIT (ppm)
	LTE Band 14		
	5MHz	10MHz	
-30	-0.0192	-0.0180	1.25
-20	-0.0167	-0.0130	1.25
-10	-0.0142	-0.0110	1.25
0	-0.0120	-0.0079	1.25
+10	-0.0065	-0.0052	1.25
+20	-0.0030	-0.0030	1.25
+30	-0.0001	0.0007	1.25
+40	0.0032	0.0040	1.25
+50	0.0058	0.0051	1.25
+60	0.0096	0.0077	1.25

4.3 OCCUPIED BANDWIDTH MEASUREMENT

4.3.1 LIMITS OF OCCUPIED BANDWIDTH MEASUREMENT

The width of a frequency band such that, below the lower and above the upper frequency limits, the mean powers emitted are each equal to a specified percentage 0.5 % of the total mean power of a given emission.

4.3.2 TEST SETUP

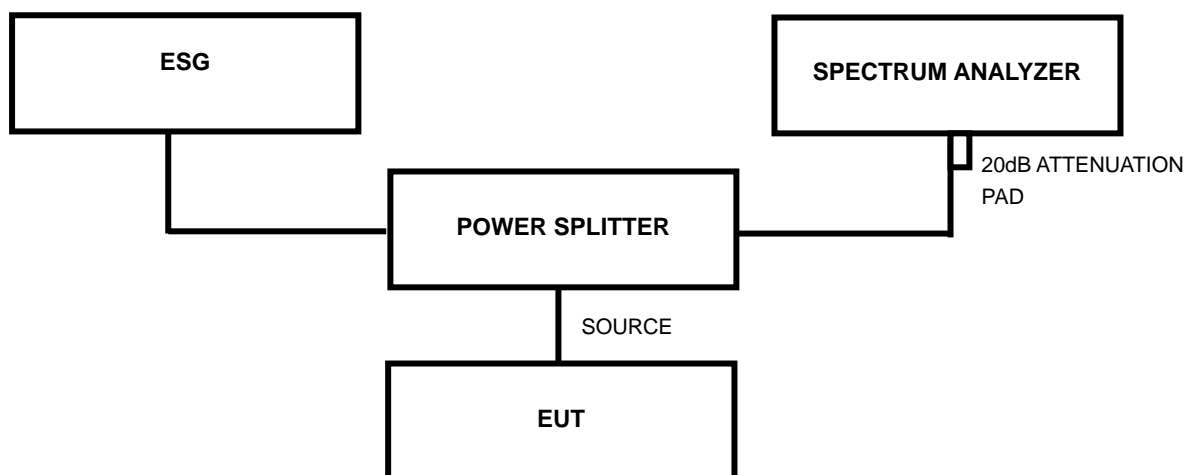

4.3.3 TEST PROCEDURES

- The conducted occupied bandwidth used the power splitter via EUT RF power connector between signal generator and spectrum analyzer.
- Use OBW measurement function of Spectrum analyzer to measure 99 % occupied bandwidth.

4.3.4 EUT OPERATING CONDITIONS

Same as 4.1.4.



BUREAU
VERITAS

Test Report No.: RF150319N004-10

4.3.5 TEST RESULTS

LTE BAND 14							
CHANNEL BANDWIDTH: 5MHz				CHANNEL BANDWIDTH: 10MHz			
CHANNEL	FREQUENCY (MHz)	99% OCCUPIED BANDWIDTH (MHz)		CHANNEL	FREQUENCY (MHz)	99% OCCUPIED BANDWIDTH (MHz)	
		QPSK	16QAM			QPSK	16QAM
23305	790.5	4.49	4.47	23330	793	8.89	8.91
23330	793	4.47	4.47				
23355	795.5	4.47	4.46				

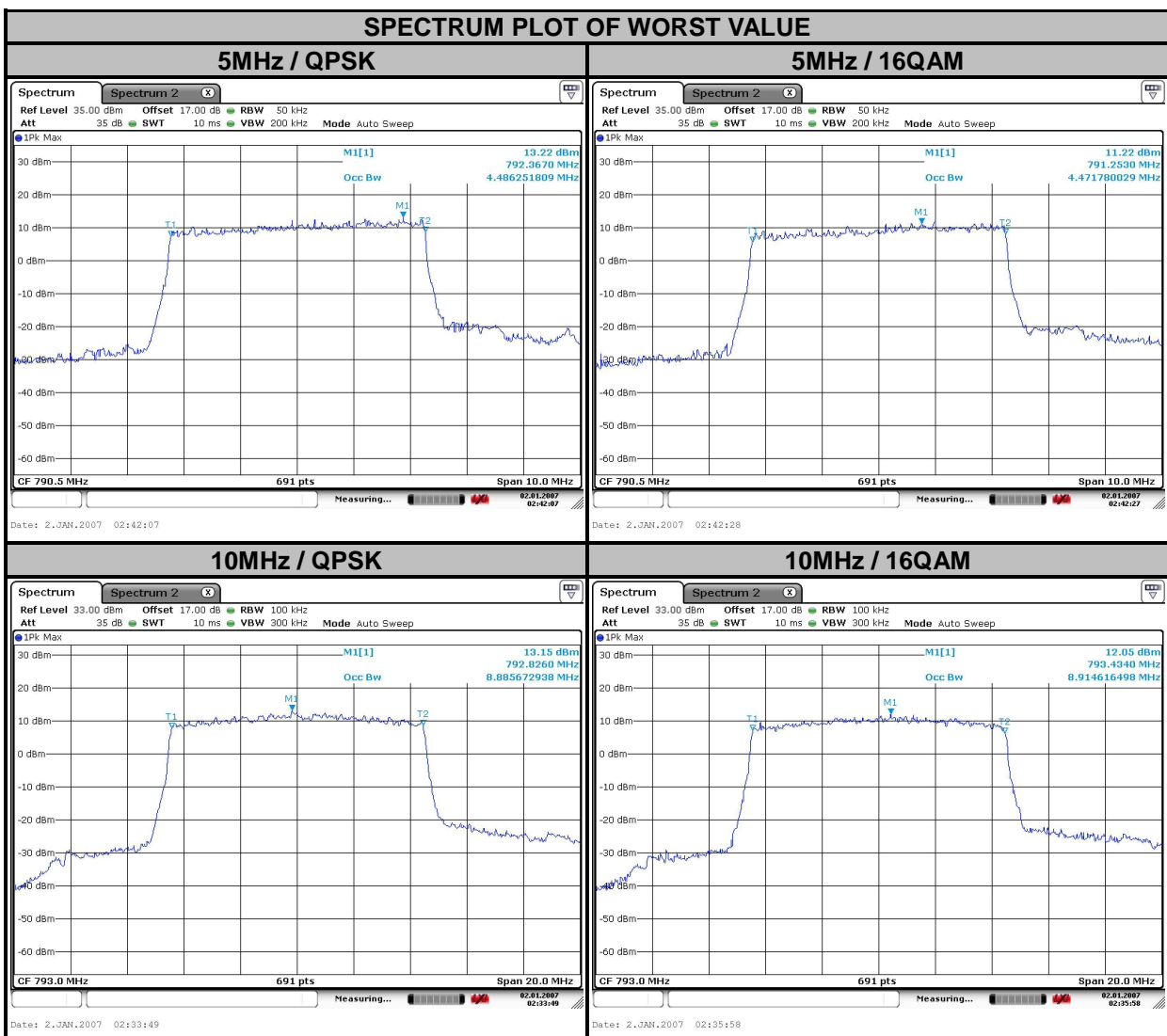



4.4 EMISSION MASK MEASUREMENT

4.4.1 LIMITS OF EMISSION MASK MEASUREMENT

Per 90.210(n), Emission mask shall comply with 90.210(b)

- (1) On any frequency removed from the assigned frequency by more than 50 percent, but not more than 100 percent of the authorized bandwidth: At least 25 dB.
- (2) On any frequency removed from the assigned frequency by more than 100 percent, but not more than 250 percent of the authorized bandwidth: At least 35 dB.
- (3) On any frequency removed from the assigned frequency by more than 250 percent of the authorized bandwidth: At least $43 + 10 \log (P)$ dB

4.4.2 TEST PROCEDURES

1. The power was measured with Agilent Spectrum Analyzer. All measurements were done at 1 channel.
2. The measurement used the power splitter via EUT RF power connector between signal generator and spectrum analyzer.
3. Record the test plot.

4.4.3 TEST SETUP

Same as Item 4.3.3

4.4.4 EUT OPERATING CONDITIONS

Same as 4.1.4.



BUREAU VERITAS

Test Report No.: RF150319N004-10

4.4.5 TEST RESULTS

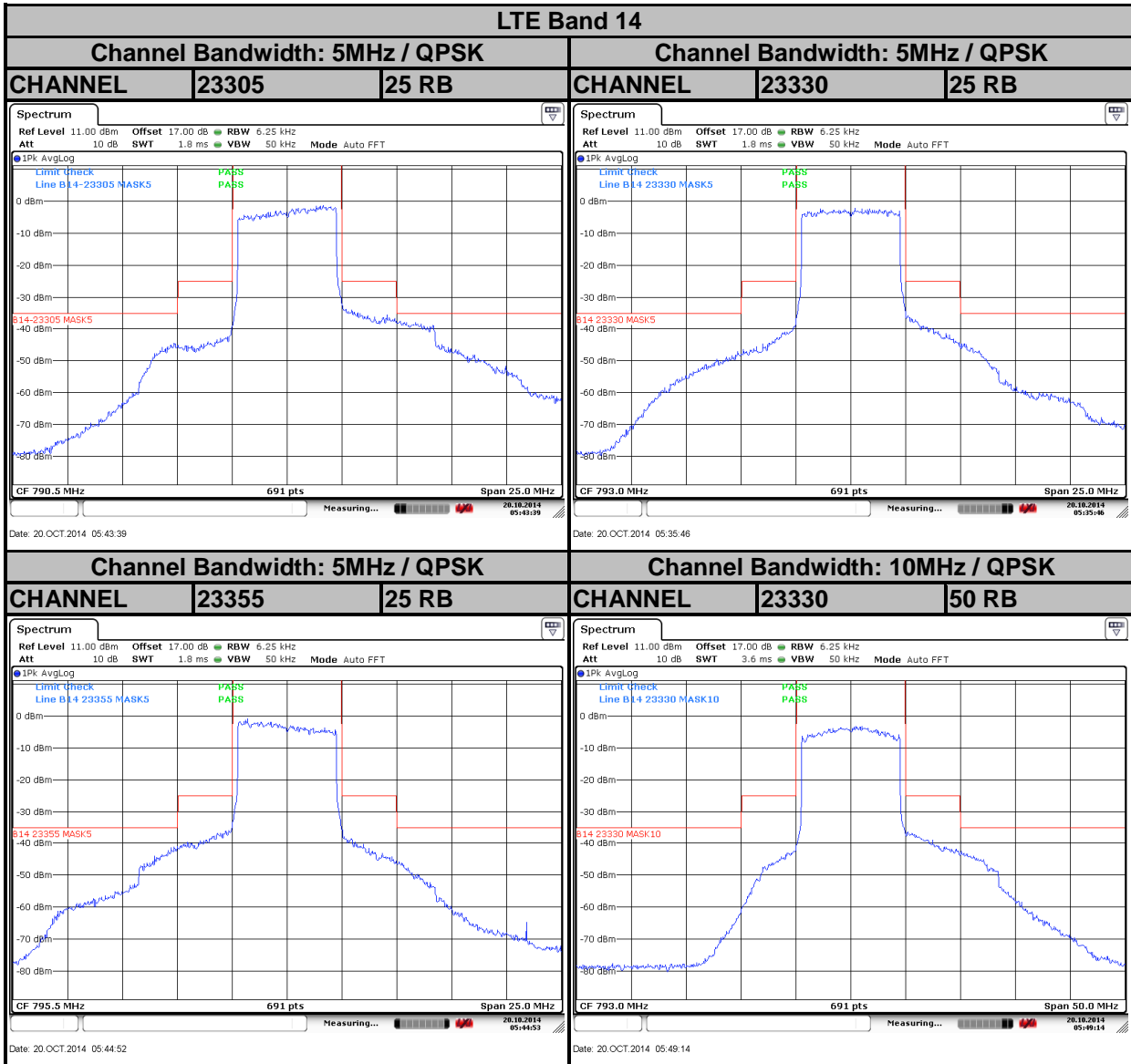

Bureau Veritas Shenzhen Co., Ltd.
Dongguan Branch

No. 34, Chenwulu Section, Guantai Rd.,
Houjie Town, Dongguan City,
Guangdong 523942, China

Tel: +86 769 8593 5656
Fax: +86 769 8593 1080
Email: customerservice.dg@cn.bureauveritas.com



BUREAU VERITAS

Test Report No.: RF150319N004-10

LTE Band 14

Channel Bandwidth: 5MHz / 16QAM

Channel Bandwidth: 5MHz / 16QAM

CHANNEL 23305 25 RB

CHANNEL 23330 25 RB

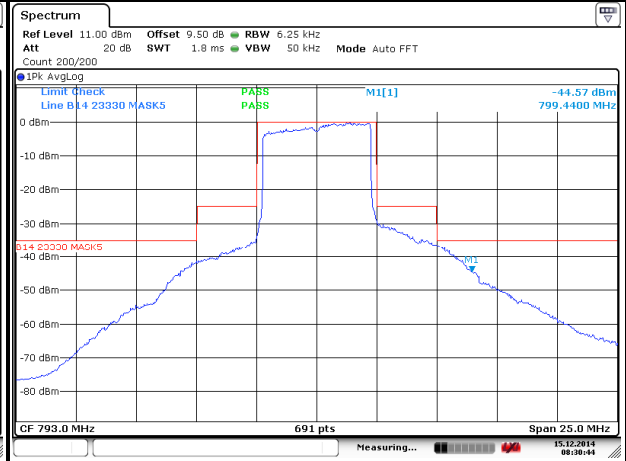
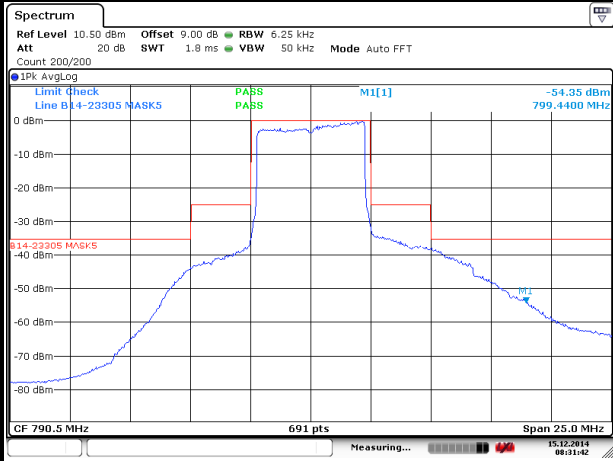

Date: 15.DEC.2014 08:31:41

Date: 15.DEC.2014 08:30:44

Channel Bandwidth: 5MHz / 16QAM

Channel Bandwidth: 10MHz / 16QAM

CHANNEL 23355 25 RB

CHANNEL 23330 50 RB

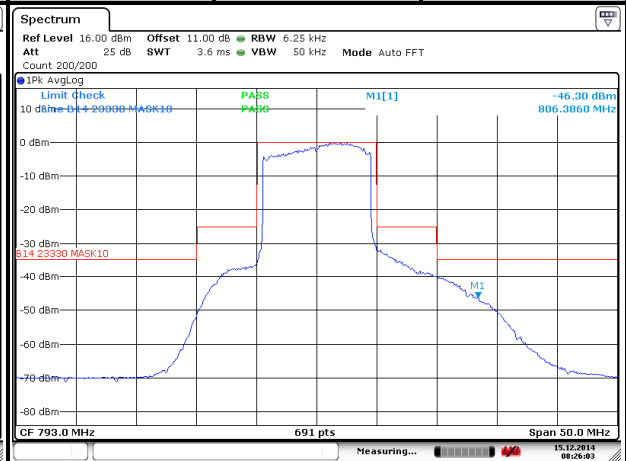
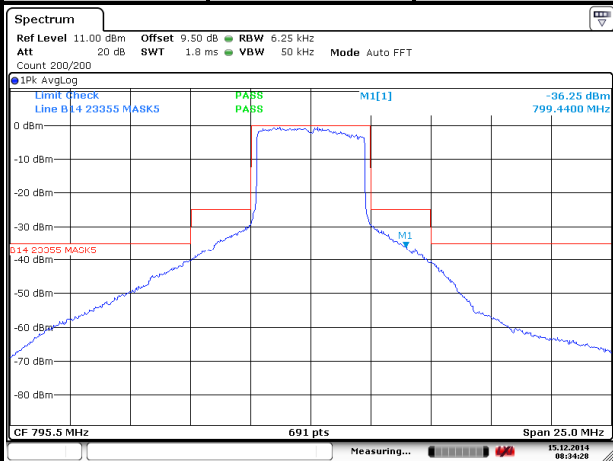

Date: 15.DEC.2014 08:34:28

Date: 15.DEC.2014 08:26:03

Bureau Veritas Shenzhen Co., Ltd.
Dongguan Branch

No. 34, Chenwulu Section, Guantai Rd.,
Houjie Town, Dongguan City,
Guangdong 523942, China

Tel: +86 769 8593 5656
Fax: +86 769 8593 1080
Email: customerservice.dg@cn.bureauveritas.com



4.5 CONDUCTED SPURIOUS EMISSIONS

4.5.1 LIMITS OF CONDUCTED SPURIOUS EMISSIONS MEASUREMENT

Transmitters operating in 758-768 MHz and 788-798 MHz bands must meet the emission limitations in 90.543 (e) of this section.

For operations in the 758–768 MHz and the 793–798 MHz bands, the power of any emission outside the licensee's frequency band(s) of operation shall be attenuated below the transmitter power (P) within the licensed band(s) of operation, measured in watts, in accordance with the following:

- (1) On all frequencies between 769–775 MHz and 799–805 MHz, by a factor not less than $65 + 10 \log (P)$ dB in a 6.25 kHz band segment, for mobile and portable stations.
- (2) On any frequency between 775-788 MHz, above 805 MHz, and below 758 MHz, by at least $43 + 10 \log (P)$ dB

4.5.2 TEST PROCEDURE

- a. The EUT was set up for the maximum peak power with LTE link data modulation. The power was measured with Agilent Spectrum Analyzer. All measurements were done at 1 channel.
- b. The conducted spurious emission used the power splitter via EUT RF power connector between signal generator and spectrum analyzer.
- c. When the spectrum scanned from 769MHz to 805MHz, The spectrum set RB=6.25kHz, VB=50kHz.
- d. When the spectrum scanned from 30MHz to 8GHz, The spectrum set RB=1MHz, VB=3MHz.

4.5.3 TEST SETUP

Same as 4.3.3



4.5.4 EUT OPERATING CONDITIONS

Same as 4.1.4.

4.5.5 TEST RESULTS

Out-Of-Band Emission Measurement

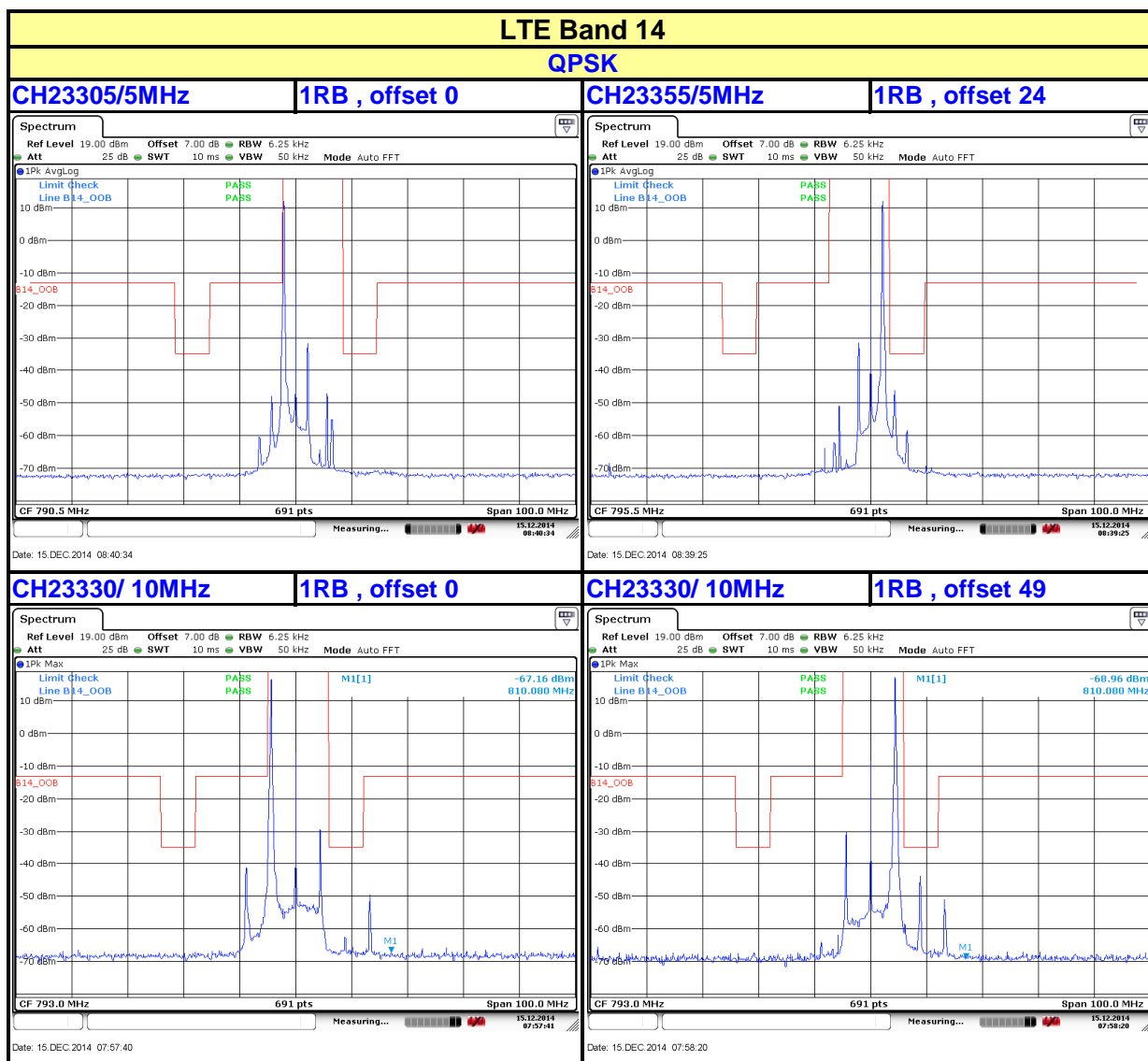



BUREAU VERITAS

Test Report No.: RF150319N004-10

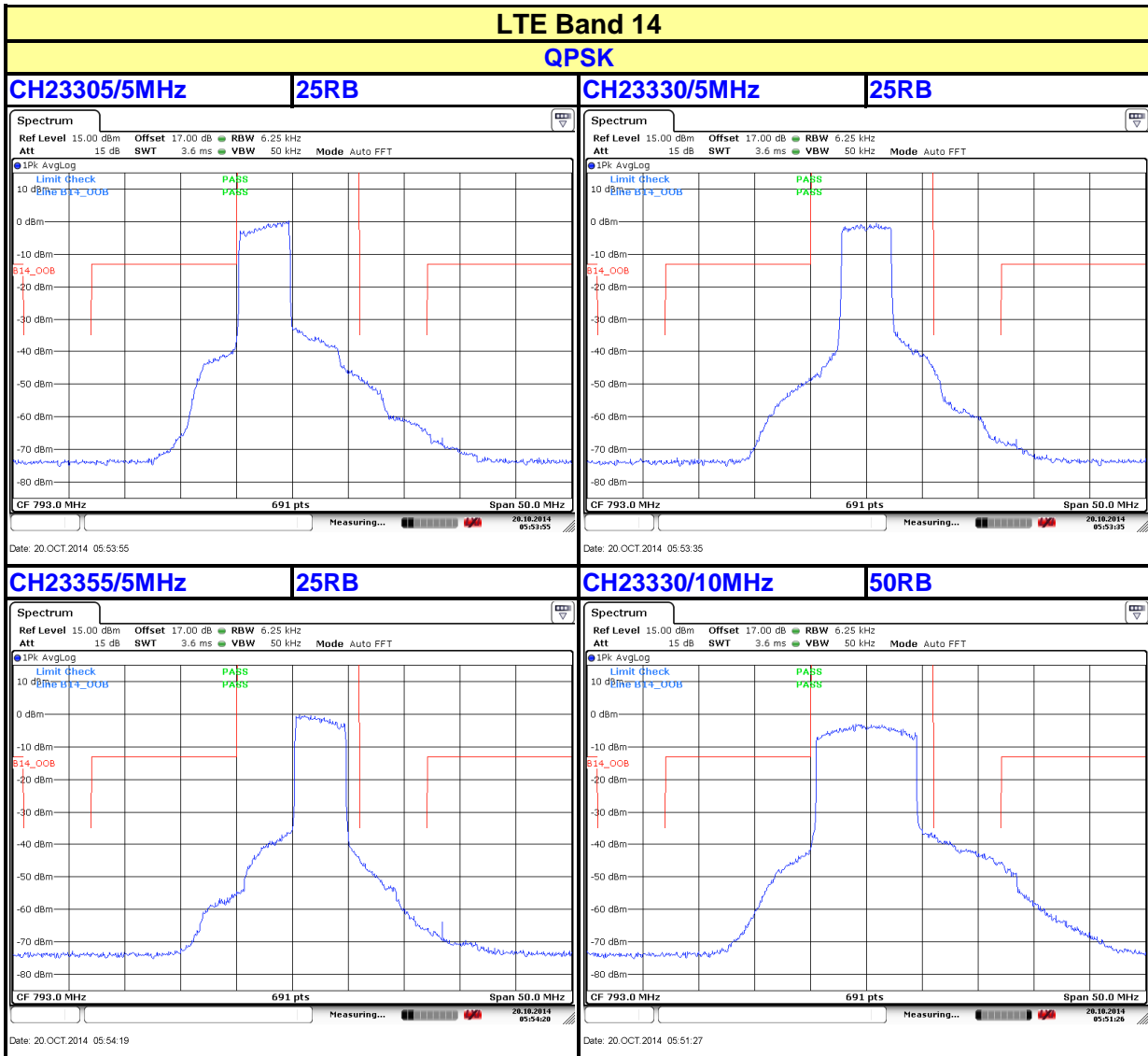

Bureau Veritas Shenzhen Co., Ltd.
Dongguan Branch

No. 34, Chenwulu Section, Guantai Rd.,
Houjie Town, Dongguan City,
Guangdong 523942, China

Tel: +86 769 8593 5656
Fax: +86 769 8593 1080
Email: customerservice.dg@cn.bureauveritas.com



BUREAU VERITAS

Test Report No.: RF150319N004-10

SPURIOUS EMISSION MEASUREMENT

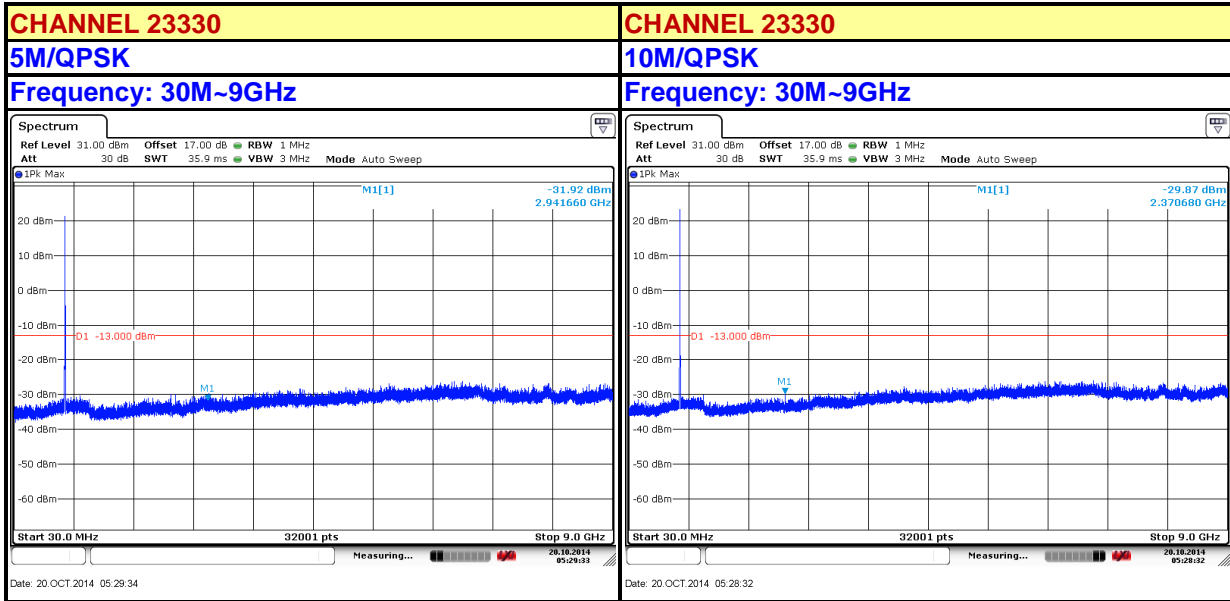

Bureau Veritas Shenzhen Co., Ltd.
Dongguan Branch

No. 34, Chenwulu Section, Guantai Rd.,
Houjie Town, Dongguan City,
Guangdong 523942, China

Tel: +86 769 8593 5656
Fax: +86 769 8593 1080
Email: customerservice.dg@cn.bureauveritas.com



4.6 RADIATED EMISSION MEASUREMENT

4.6.1 LIMITS OF RADIATED EMISSION MEASUREMENT

(1) The power of any emission outside a licensee's frequency block shall be attenuated below the transmitter power (P) by at least $43 + 10 \log_{10}(P)$ dB. The limit of emission equal to -13dBm .

(2) For operations in the 763–775 MHz and 793–805 MHz bands, all emissions including harmonics in the band 1559–1610 MHz shall be limited to -70 dBW/MHz equivalent isotropically radiated power (EIRP) for wideband signals, and -80 dBW EIRP for discrete emissions of less than 700 Hz bandwidth. For the purpose of equipment authorization, a transmitter shall be tested with an antenna that is representative of the type that will be used with the equipment in normal operation.

4.6.2 TEST INSTRUMENTS

Same as 4.1.2.



4.6.3 TEST PROCEDURES

- a. The EUT was placed on the top of a rotating table 0.8 meters above the ground. The table was rotated 360 degrees to determine the position of the highest radiation.
- b. The EUT was set 3 meters away from the receiving antenna, which was mounted on antenna tower and its position at 0.8 m above the ground.
- c. For each suspected emission, the EUT was arranged to its worst case and the rotatable table was turned from 0 degrees to 360 degrees to find the maximum reading and recorded the value.
- d. Repeat step a ~ c for horizontal polarization.

NOTE: The resolution bandwidth of spectrum analyzer is 1 MHz and the video bandwidth is 3 MHz.

4.6.4 DEVIATION FROM TEST STANDARD

No deviation

4.6.5 TEST SETUP

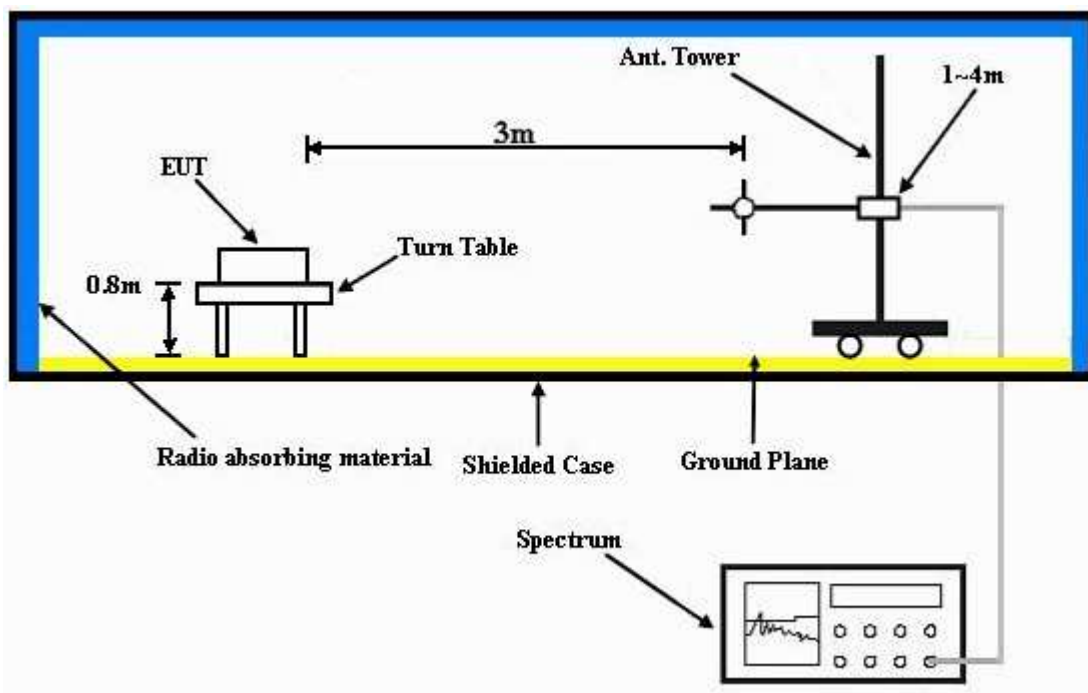

For the actual test configuration, please refer to the attached file (Test Setup Photo).

4.6.6 EUT OPERATING CONDITIONS

Same as 4.1.4.



4.6.7 TEST RESULTS

BELOW 1GHz WORST-CASE DATA : LTE BAND 14

SPURIOUS EMISSION FREQUENCY RANGE	Below 1000MHz	OPERATING CHANNEL	Channel 23330
--	---------------	--------------------------	---------------

SPURIOUS EMISSION LEVEL				
Frequency (MHz)	Antenna Polarization	Level (dBm)	Limit (dBm)	Margin (dB)
33.11	H	-69.71	-13	-56.71
112.39	H	-73.42	-13	-60.42
159.02	H	-72.71	-13	-59.71
266.28	H	-69.51	-13	-56.51
412.4	H	-64.37	-13	-51.37
594.28	H	-60.77	-13	-47.77

NOTE: The emission behavior belongs to narrowband spurious emission.

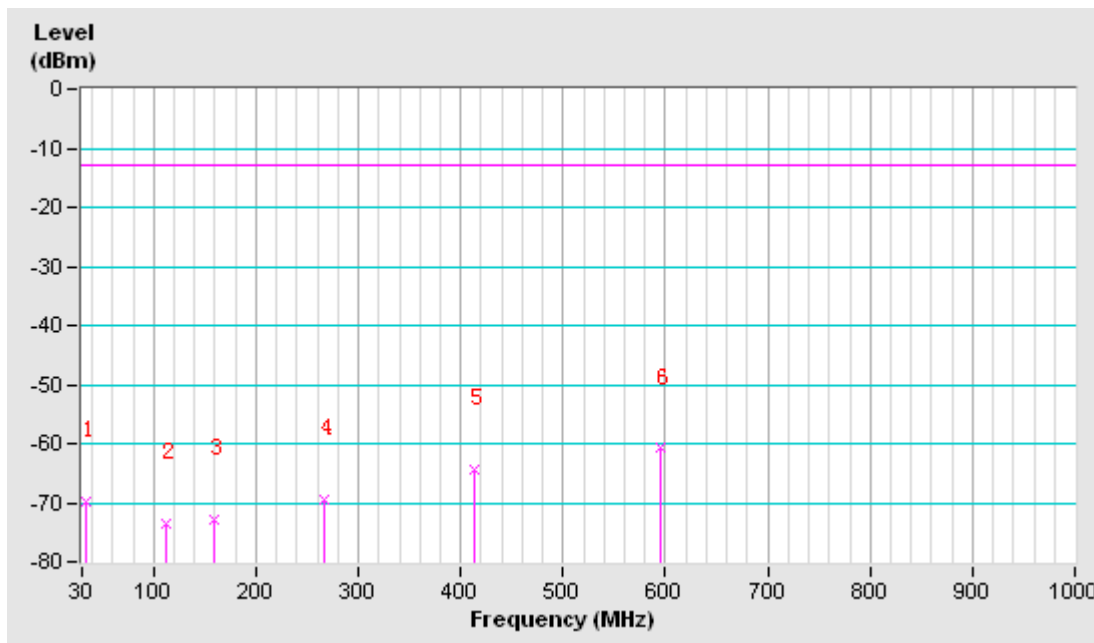



BUREAU VERITAS

Test Report No.: RF150319N004-10

SPURIOUS EMISSION FREQUENCY RANGE	Below 1000MHz	OPERATING CHANNEL	Channel 21100
--	---------------	--------------------------	---------------

SPURIOUS EMISSION LEVEL				
Frequency (MHz)	Antenna Polarization	Level (dBm)	Limit (dBm)	Margin (dB)
30	V	-67.99	-13	-54.99
180.79	V	-72.96	-13	-59.96
266.28	V	-69.79	-13	-56.79
452.82	V	-64.25	-13	-51.25
536.76	V	-62.88	-13	-49.88
693.77	V	-58.51	-13	-45.51

NOTE: The emission behavior belongs to narrowband spurious emission.

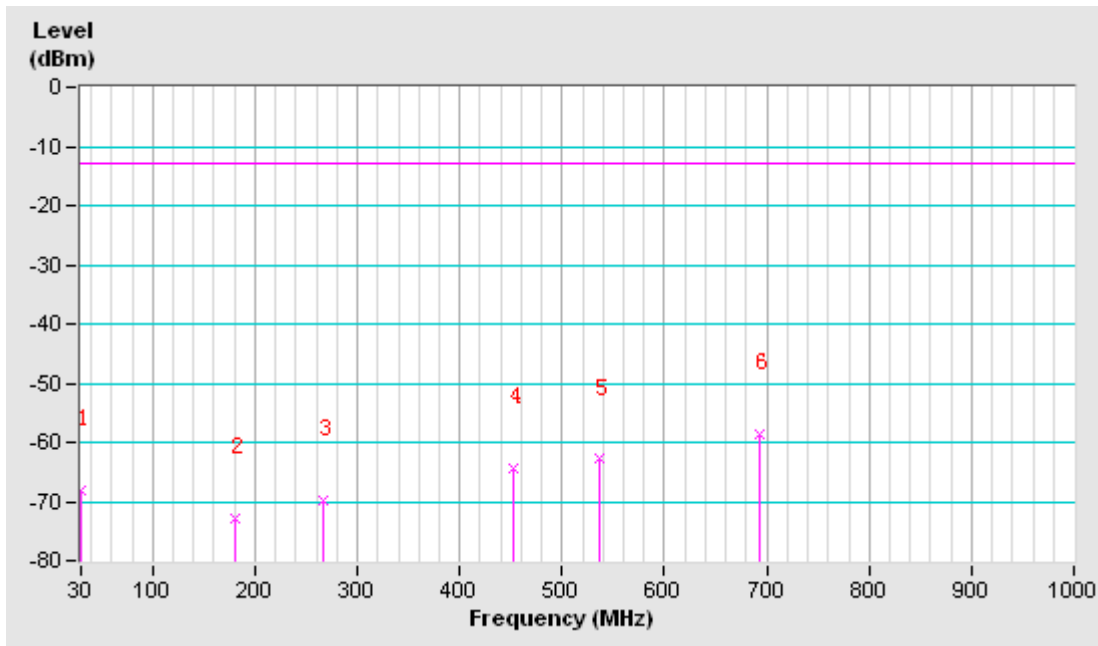



Test Report No.: RF150319N004-10

ABOVE 1GHz

CHANNEL BANDWIDTH: 5MHz / QPSK

MODE	TX channel 23330	FREQUENCY RANGE	Above 1000MHz
ENVIRONMENTAL CONDITIONS	24deg. C, 60%RH	INPUT POWER	DC 5V from adapter
TESTED BY	Blue Zheng		

ANTENNA POLARITY & TEST DISTANCE: HORIZONTAL AT 3 M							
No.	Freq. (MHz)	Reading (dBm)	Limit (dBm)	S.G Power Value (dBm)	Correction Factor (dB)	EIRP (dBm)	Margin (dB)
1	1586	-68.41	-50	-66.09	2.57	-63.52	-13.52
2	2379	-68.55	-13	-61.57	1.83	-59.74	-46.74
ANTENNA POLARITY & TEST DISTANCE: VERTICAL AT 3 M							
No.	Freq. (MHz)	Reading (dBm)	Limit (dBm)	S.G Power Value (dBm)	Correction Factor (dB)	EIRP (dBm)	Margin (dB)
1	1586	-69.82	-50	-64.25	2.57	-61.68	-11.68
2	2379	-69.74	-13	-60.86	1.83	-59.03	-46.03

NOTE: EIRP (dBm) = S.G Power Value (dBm) + Correction Factor (dB).



BUREAU
VERITAS

Test Report No.: RF150319N004-10

CHANNEL BANDWIDTH: 10MHz / QPSK

MODE	TX channel 23330	FREQUENCY RANGE	Above 1000MHz
ENVIRONMENTAL CONDITIONS	24deg. C, 60%RH	INPUT POWER	DC 5V from adapter
TESTED BY	Blue Zheng		

ANTENNA POLARITY & TEST DISTANCE: HORIZONTAL AT 3 M

No.	Freq. (MHz)	Reading (dBm)	Limit (dBm)	S.G Power Value (dBm)	Correction Factor (dB)	EIRP (dBm)	Margin (dB)
1	1586	-68.45	-50	-66.13	2.57	-63.56	-13.56
2	2379	-68.65	-13	-61.67	1.83	-59.84	-46.84

ANTENNA POLARITY & TEST DISTANCE: VERTICAL AT 3 M

No.	Freq. (MHz)	Reading (dBm)	Limit (dBm)	S.G Power Value (dBm)	Correction Factor (dB)	EIRP (dBm)	Margin (dB)
1	1586	-69.91	-50	-64.34	2.57	-61.77	-11.77
2	2379	-69.52	-13	-60.64	1.83	-58.81	-45.81

NOTE: EIRP (dBum) = S.G Power Value (dBm) + Correction Factor (dB).



Test Report No.: RF150319N004-10

5 INFORMATION ON THE TESTING LABORATORIES

We, Bureau Veritas Shenzhen Co., Ltd. Dongguan Branch, were founded in 2002 to provide our best service in EMC, Radio, Telecom and Safety consultation. Our laboratories are accredited and approved according to ISO/IEC 17025.

If you have any comments, please feel free to contact us at the following:

Dongguan EMC/RF Lab:

Tel: +86-769-85935656

Fax: +86-769-85931080

Email: customerservice.dg@cn.bureauveritas.com

Web Site: www.adt.com.tw

The address and road map of all our labs can be found in our web site also.



**BUREAU
VERITAS**

Test Report No.: RF150319N004-10

6 APPENDIX A – MODIFICATIONS RECORDERS FOR ENGINEERING CHANGES TO THE EUT BY THE LAB

No any modifications are made to the EUT by the lab during the test.

---END---