



**BUREAU
VERITAS**

Test Report No.: RF140812N017-5



Test Lab
Cert 2951.01

TEST REPORT



Applicant	ecom instruments GmbH
Address	Industriestraße. 2, 97959 Assamstadt, Germany

Manufacturer or Supplier	ecom instruments GmbH
Address	Industriestraße. 2, 97959 Assamstadt, Germany
Product	LTE Smartphone
Brand Name	ecom MOBILE SAFETY
Model	Ex-Handy 09
FCC ID	XAM500055GR01
Additional Model & Model Difference	N/A
Date of tests	Aug. 12, 2014 ~ Oct. 12, 2014

the tests have been carried out according to the requirements of the following standard:

FCC Part 15, Subpart E, Section 15.407

CONCLUSION: The submitted sample was found to COMPLY with the test requirement

Tested by Yuqiang Yin Project Engineer / EMC Department	Approved by Glyn He Supervisor / EMC Department
	 Date: Oct. 15, 2014

This report is for your exclusive use. Any copying or replication of this report to or for any other person or entity, or use of our name or trademark, is permitted only with our prior written permission. This report sets forth our findings solely with respect to the test samples identified herein. The results set forth in this report are not indicative or representative of the quality or characteristics of the lot from which a test sample was taken or any similar or identical product unless specifically and expressly noted. Our report includes all of the tests requested by you and the results thereof based upon the information that you provided to us. You have 60 days from date of issuance of this report to notify us of any material error or omission caused by our negligence, provided, however, that such notice shall be in writing and shall specifically address the issue you wish to raise. A failure to raise such issue within the prescribed time shall constitute your unqualified acceptance of the completeness of this report, the tests conducted and the correctness of the report contents. Unless specific mention, the uncertainty of measurement has been explicitly taken into account to declare the compliance or non-compliance to the specification



TABLE OF CONTENTS

RELEASE CONTROL RECORD 4

1 SUMMARY OF TEST RESULTS..... 5

2 MEASUREMENT UNCERTAINTY 5

3 GENERAL INFORMATION..... 6

3.1 GENERAL DESCRIPTION OF EUT..... 6

3.2 DESCRIPTION OF TEST MODES..... 8

 3.2.1 TEST MODE APPLICABILITY AND TESTED CHANNEL DETAIL..... 10

3.3 DUTY CYCLE OF TEST SIGNAL 13

3.4 DESCRIPTION OF SUPPORT UNITS..... 13

 3.4.1 CONFIGURATION OF SYSTEM UNDER TEST 15

3.5 GENERAL DESCRIPTION OF APPLIED STANDARDS..... 15

4 TEST TYPES AND RESULTS..... 16

4.1 RADIATED EMISSION AND BANDEDGE MEASUREMENT 16

 4.1.1 LIMITS OF RADIATED EMISSION AND BANDEDGE MEASUREMENT..... 16

 4.1.2 LIMITS OF UNWANTED EMISSION OUT OF THE RESTRICTED BANDS 16

 4.1.3 TEST INSTRUMENTS..... 17

 4.1.4 TEST PROCEDURES 18

 4.1.5 DEVIATION FROM TEST STANDARD 18

 4.1.6 TEST SETUP..... 19

 4.1.7 EUT OPERATING CONDITION 19

 4.1.8 TEST RESULTS 20

4.2 CONDUCTED EMISSION MEASUREMENT..... 55

 4.2.1 LIMITS OF CONDUCTED EMISSION MEASUREMENT 55

 4.2.2 TEST INSTRUMENTS..... 55

 4.2.3 TEST PROCEDURES 55

 4.2.4 DEVIATION FROM TEST STANDARD 56

 4.2.5 TEST SETUP..... 56

 4.2.6 EUT OPERATING CONDITIONS 56

 4.2.7 TEST RESULTS 57

4.3 MAXIMUM CONDUCTED OUTPUT POWER MEASUREMENT 59

 4.3.1 LIMITS OF MAXIMUM CONDUCTED OUTPUT POWER MEASUREMENT 59



4.3.2	TEST SETUP	59
4.3.3	TEST INSTRUMENTS.....	60
4.3.4	TEST PROCEDURE.....	60
4.3.5	DEVIATION FROM TEST STANDARD	60
4.3.6	EUT OPERATING CONDITIONS	61
4.3.7	TEST RESULTS	62
4.4	PEAK POWER SPECTRAL DENSITY MEASUREMENT.....	66
4.4.1	LIMITS OF PEAK POWER SPECTRAL DENSITY MEASUREMENT	66
4.4.2	TEST SETUP.....	66
4.4.3	TEST INSTRUMENTS.....	66
4.4.4	TEST PROCEDURES	66
4.4.5	DEVIATION FROM TEST STANDARD	67
4.4.6	EUT OPERATING CONDITIONS	67
4.4.7	TEST RESULTS	68
4.5	FREQUENCY STABILITY	71
4.5.1	LIMITS OF FREQUENCY STABILITY MEASUREMENT	71
4.5.2	TEST SETUP.....	71
4.5.3	TEST INSTRUMENTS.....	71
4.5.4	TEST PROCEDURE.....	72
4.5.5	DEVIATION FROM TEST STANDARD	72
4.5.6	EUT OPERATING CONDITION	72
4.5.7	TEST RESULTS	73
5	PHOTOGRAPHS OF THE TEST CONFIGURATION	74
6	APPENDIX A – MODIFICATIONS RECORDERS FOR ENGINEERING CHANGES TO THE EUT BY THE LAB.....	75



**BUREAU
VERITAS**

Test Report No.: RF140812N017-5

RELEASE CONTROL RECORD

ISSUE NO.	REASON FOR CHANGE	DATE ISSUED
RF140812N017-5	Original release	Oct. 15, 2014



1 SUMMARY OF TEST RESULTS

The EUT has been tested according to the following specifications:

APPLIED STANDARD: FCC PART 15, SUBPART E (SECTION 15.407)			
STANDARD SECTION	TEST TYPE AND LIMIT	RESULT	REMARK
15.407(b)(5)	AC Power Conducted Emission	PASS	Meet the requirement of limit. Minimum passing margin is -13.30dB at 0.62311MHz.
15.407(b/1/2/3)(b)(5)	Electric Field Strength Spurious Emissions, 30MHz ~ 40000MHz	PASS	Meet the requirement of limit. Minimum passing margin is -3.5dB at 5725MHz.
15.407(a/1/2/3)	Maximum conducted output Power	PASS	Meet the requirement of limit.
15.407(a/1/2/3)	Peak Power Spectral Density	PASS	Meet the requirement of limit.
15.407(g)	Frequency Stability	PASS	Meet the requirement of limit.
15.203	Antenna Requirement	PASS	No antenna connector is used.

2 MEASUREMENT UNCERTAINTY

Where relevant, the following measurement uncertainty levels have been estimated for tests performed on the EUT as specified in CISPR 16-4-2:

MEASUREMENT	FREQUENCY	UNCERTAINTY
Conducted emissions	9kHz~30MHz	2.66dB
Radiated emissions	9KHz ~ 30MHz	2.74dB
	30MHz ~ 1GMHz	3.55dB
	1GHz ~ 18GHz	4.84dB
	18GHz ~ 40GHz	1.94dB

This uncertainty represents an expanded uncertainty expressed at approximately the 95% confidence level using a coverage factor of k = 2.



3 GENERAL INFORMATION

3.1 GENERAL DESCRIPTION OF EUT

EUT	LTE Smartphone
MODEL NO.	Ex-Handy 09
TYPE NUMBER	L12V011BB, L12V011AB, L13V011AB
POWER SUPPLY	5.0Vdc (adapter or host equipment) 3.7Vdc (Li-ion battery)
MODULATION TYPE	64QAM, 16QAM, QPSK, BPSK
MODULATION TECHNOLOGY	OFDM
TRANSFER RATE	802.11a: 54.0/ 48.0/ 36.0/ 24.0/ 18.0/ 12.0/ 9.0/ 6.0Mbps 802.11n: up to MCS7
OPERATING FREQUENCY	5180 ~ 5240MHz, 5260 ~ 5320MHz 5500 ~ 5700MHz, 5745 ~ 5805MHz
NUMBER OF CHANNEL	5180 ~ 5240MHz: 4 for 802.11a, 802.11n (20MHz) 2 for 802.11n (40MHz) 5260 ~ 5320MHz: 4 for 802.11a, 802.11n (20MHz) 2 for 802.11n (40MHz) 5500 ~ 5700MHz: 8 for 802.11a, 802.11n (20MHz) 3 for 802.11n (40MHz) 5745 ~ 5805MHz: 4 for 802.11a, 802.11n (20MHz) 2 for 802.11n (40MHz)
OUTPUT POWER	7.780mW for 5180 ~ 5240MHz 7.852mW for 5260 ~ 5320MHz 8.035mW for 5500 ~ 5700MHz 7.638mW for 5745 ~ 5805MHz
ANTENNA TYPE	5180 ~ 5240MHz: PIFA Antenna with 1.8dBi gain 5260 ~ 5320MHz: PIFA Antenna with 1.8dBi gain 5500 ~ 5700MHz: PIFA Antenna with 1.5dBi gain 5745 ~ 5805MHz: PIFA Antenna with 1.5dBi gain
I/O PORTS	Refer to user's manual
CABLE SUPPLIED	See note 3

NOTE:

- For a more detailed features description, please refer to the manufacturer's specifications or the user's manual.
- The EUT was powered by the following adapter:



ADAPTER	
BRAND:	Sonim
MODEL:	S11C02
INPUT:	AC 100-240V, 450mA
OUTPUT:	DC 5V, 2100mA

3. The EUT matched the following USB cable:

USB CABLE	
BRAND:	ecom MOBILE SAFETY
MODEL:	Safety Box SB S01
SIGNAL LINE:	1.1 METER

4. The EUT incorporates a SISO function. Physically, the EUT provides one completed transmitters and one receivers.

MODULATION MODE	TX FUNCTION
802.11a	1TX/1RX
802.11n (20MHz)	1TX/1RX
802.11n (40MHz)	1TX/1RX

5. For the test results, the EUT had been tested with all conditions. But only the worst case was shown in test report.



3.2 DESCRIPTION OF TEST MODES

FOR 5150 ~ 5250MHz

4 channels are provided for 802.11a, 802.11n (20MHz):

CHANNEL	FREQUENCY	CHANNEL	FREQUENCY
36	5180 MHz	44	5220 MHz
40	5200 MHz	48	5240 MHz

2 channels are provided for 802.11n (40MHz):

CHANNEL	FREQUENCY	CHANNEL	FREQUENCY
38	5190 MHz	46	5230 MHz

FOR 5250 ~ 5350MHz

4 channels are provided for 802.11a, 802.11n (20MHz):

CHANNEL	FREQUENCY	CHANNEL	FREQUENCY
52	5260 MHz	60	5300 MHz
56	5280 MHz	64	5320 MHz

2 channels are provided for 802.11n (40MHz):

CHANNEL	FREQUENCY	CHANNEL	FREQUENCY
54	5270 MHz	62	5310 MHz



FOR 5470 ~ 5725MHz

8 channels are provided for 802.11a, 802.11n (20MHz):

CHANNEL	FREQUENCY	CHANNEL	FREQUENCY
100	5500 MHz	116	5580 MHz
104	5520 MHz	132	5660 MHz
108	5540 MHz	136	5680 MHz
112	5560 MHz	140	5700 MHz

3 channels are provided for 802.11n (40MHz):

CHANNEL	FREQUENCY	CHANNEL	FREQUENCY
102	5510 MHz	134	5670 MHz
110	5550 MHz		

FOR 5725 ~ 5850MHz

4 channels are provided for 802.11a, 802.11n (20MHz):

CHANNEL	FREQUENCY	CHANNEL	FREQUENCY
149	5745MHz	161	5805MHz
153	5765MHz		
157	5785MHz		

2 channels are provided for 802.11n (40MHz):

CHANNEL	FREQUENCY	CHANNEL	FREQUENCY
151	5755MHz	159	5795MHz



3.2.1 TEST MODE APPLICABILITY AND TESTED CHANNEL DETAIL

EUT CONFIGURE MODE	APPLICABLE TO				DESCRIPTION
	RE≥1G	RE<1G	PLC	APCM	
A	√	√	√	-	Powered by Adapter with wifi(5G) link
B	-	-	-	√	Powered by Battery with wifi(5G) link
C	-	-	-	-	Powered by USB with wifi(5G) link

Where **RE≥1G**: Radiated Emission above 1GHz **RE<1G**: Radiated Emission below 1GHz
PLC: Power Line Conducted Emission **APCM**: Antenna Port Conducted Measurement

NOTE:
The EUT had been pre-tested on the positioned of each 3 axis. The worst case was found when positioned on **Y-plane**.
NOTE: "-" means no effect.

RADIATED EMISSION TEST (ABOVE 1GHz):

- Pre-Scan has been conducted to determine the worst-case mode from all possible combinations between available modulations, data rates and antenna ports (if EUT with antenna diversity architecture).
- Following channel(s) was (were) selected for the final test as listed below.

EUT CONFIGURE MODE	MODE	FREQ. BAND (MHz)	AVAILABLE CHANNEL	TESTED CHANNEL	MODULATION TECHNOLOGY	MODULATION TYPE	DATA RATE (Mbps)
A	802.11a	5180-5240	36 to 48	36, 40, 48	OFDM	BPSK	6.0
A	802.11n (20MHz)		36 to 48	36, 40, 48	OFDM	BPSK	MCS0
A	802.11n (40MHz)		38 to 46	38, 46	OFDM	BPSK	MCS0
A	802.11a	5260-5320	52 to 64	52, 60, 64	OFDM	BPSK	6.0
A	802.11n (20MHz)		52 to 64	52, 60, 64	OFDM	BPSK	MCS0
A	802.11n (40MHz)		54 to 62	54, 62	OFDM	BPSK	MCS0
A	802.11a	5500-5700	100 to 140	100, 116, 140	OFDM	BPSK	6.0
A	802.11n (20MHz)		100 to 140	100, 116, 140	OFDM	BPSK	MCS0
A	802.11n (40MHz)		102 to 134	102, 110, 134	OFDM	BPSK	MCS0
A	802.11a	5725-5805	149 to 161	149, 157, 161	OFDM	BPSK	6.0
A	802.11n (20MHz)		149 to 161	149, 157, 161	OFDM	BPSK	MCS0
A	802.11n (40MHz)		151 to 159	151, 159	OFDM	BPSK	MCS0

RADIATED EMISSION TEST (BELOW 1GHz):

- Pre-Scan has been conducted to determine the worst-case mode from all possible combinations between available modulations, data rates and antenna ports (if EUT with antenna diversity architecture).
- Following channel(s) was (were) selected for the final test as listed below.

EUT CONFIGURE MODE	MODE	FREQ. BAND (MHz)	AVAILABLE CHANNEL	TESTED CHANNEL	MODULATION TECHNOLOGY	MODULATION TYPE	DATA RATE (Mbps)
A	802.11a	5180-5320	36 to 64	36	OFDM	BPSK	6.0



POWER LINE CONDUCTED EMISSION TEST:

- Pre-Scan has been conducted to determine the worst-case mode from all possible combinations between available modulations, data rates and antenna ports (if EUT with antenna diversity architecture).
- Following channel(s) was (were) selected for the final test as listed below.

EUT CONFIGURE MODE	MODE	FREQ. BAND (MHz)	AVAILABLE CHANNEL	TESTED CHANNEL	MODULATION TECHNOLOGY	MODULATION TYPE	DATA RATE (Mbps)
A	802.11a	5180-5320	36 to 64	36	OFDM	BPSK	6.0

BANDEDGE MEASUREMENT:

- Pre-Scan has been conducted to determine the worst-case mode from all possible combinations between available modulations, data rates and antenna ports (if EUT with antenna diversity architecture).
- Following channel(s) was (were) selected for the final test as listed below.

EUT CONFIGURE MODE	MODE	FREQ. BAND (MHz)	AVAILABLE CHANNEL	TESTED CHANNEL	MODULATION TECHNOLOGY	MODULATION TYPE	DATA RATE (Mbps)
A	802.11a	5180-5240	36 to 48	36, 48	OFDM	BPSK	6.0
A	802.11n (20MHz)		36 to 48	36, 48	OFDM	BPSK	MCS0
A	802.11n (40MHz)		38 to 46	38, 46	OFDM	BPSK	MCS0
A	802.11a	5260-5320	52 to 64	52, 64	OFDM	BPSK	6.0
A	802.11n (20MHz)		52 to 64	52, 64	OFDM	BPSK	MCS0
A	802.11n (40MHz)		54 to 62	54, 62	OFDM	BPSK	MCS0
A	802.11a	5500-5700	100 to 140	100, 140	OFDM	BPSK	6.0
A	802.11n (20MHz)		100 to 140	100, 140	OFDM	BPSK	MCS0
A	802.11n (40MHz)		102 to 134	102, 134	OFDM	BPSK	MCS0
A	802.11a	5725-5805	149 to 161	149, 161	OFDM	BPSK	6.0
A	802.11n (20MHz)		149 to 161	149, 161	OFDM	BPSK	MCS0
A	802.11n (40MHz)		151 to 159	151, 159	OFDM	BPSK	MCS0

**ANTENNA PORT CONDUCTED MEASUREMENT:**

- This item includes all test value of each mode, but only includes spectrum plot of worst value of each mode.
- Pre-Scan has been conducted to determine the worst-case mode from all possible combinations between available modulations, data rates and antenna ports (if EUT with antenna diversity architecture).
- Following channel(s) was (were) selected for the final test as listed below.

EUT CONFIGURE MODE	MODE	FREQ. BAND (MHz)	AVAILABLE CHANNEL	TESTED CHANNEL	MODULATION TECHNOLOGY	MODULATION TYPE	DATA RATE (Mbps)
B	802.11a	5180-5240	36 to 48	36, 40, 48	OFDM	BPSK	6.0
B	802.11n (20MHz)		36 to 48	36, 40, 48	OFDM	BPSK	MCS0
B	802.11n (40MHz)		38 to 46	38, 46	OFDM	BPSK	MCS0
B	802.11a	5260-5320	52 to 64	52, 60, 64	OFDM	BPSK	6.0
B	802.11n (20MHz)		52 to 64	52, 60, 64	OFDM	BPSK	MCS0
B	802.11n (40MHz)		54 to 62	54, 62	OFDM	BPSK	MCS0
B	802.11a	5500-5700	100 to 140	100, 116, 140	OFDM	BPSK	6.0
B	802.11n (20MHz)		100 to 140	100, 116, 140	OFDM	BPSK	MCS0
B	802.11n (40MHz)		102 to 134	102, 110, 134	OFDM	BPSK	MCS0
B	802.11a	5725-5805	149 to 161	149, 157, 161	OFDM	BPSK	6.0
B	802.11n (20MHz)		149 to 161	149, 157, 161	OFDM	BPSK	MCS0
B	802.11n (40MHz)		151 to 159	151, 159	OFDM	BPSK	MCS0

TEST CONDITION:

APPLICABLE TO	ENVIRONMENTAL CONDITIONS	INPUT POWER	TESTED BY
RE<1G	23deg. C, 62%RH	DC 5V By Adapter	Blue Zheng
RE≥1G	23deg. C, 62%RH	DC 5V By Adapter	Blue Zheng
PLC	24deg. C, 61%RH	DC 5V By Adapter	Yuqiang Yin
APCM	23.5deg. C, 60%RH	DC 3.7V By battery	Yuqiang Yin



3.3 DUTY CYCLE OF TEST SIGNAL

Duty cycle of test signal is < 98%, duty factor shall be considered.

802.11a: Duty cycle = 1.384/1.565 = 0.884, Duty factor = 10 * log(1/0.884) = 0.54

802.11n (20MHz): Duty cycle = 1.297/1.478 = 0.878, Duty factor = 10 * log(1/0.878) = 0.57

802.11n (40MHz): Duty cycle = 0.654/0.836 = 0.782, Duty factor = 10 * log(1/0.782) = 1.07

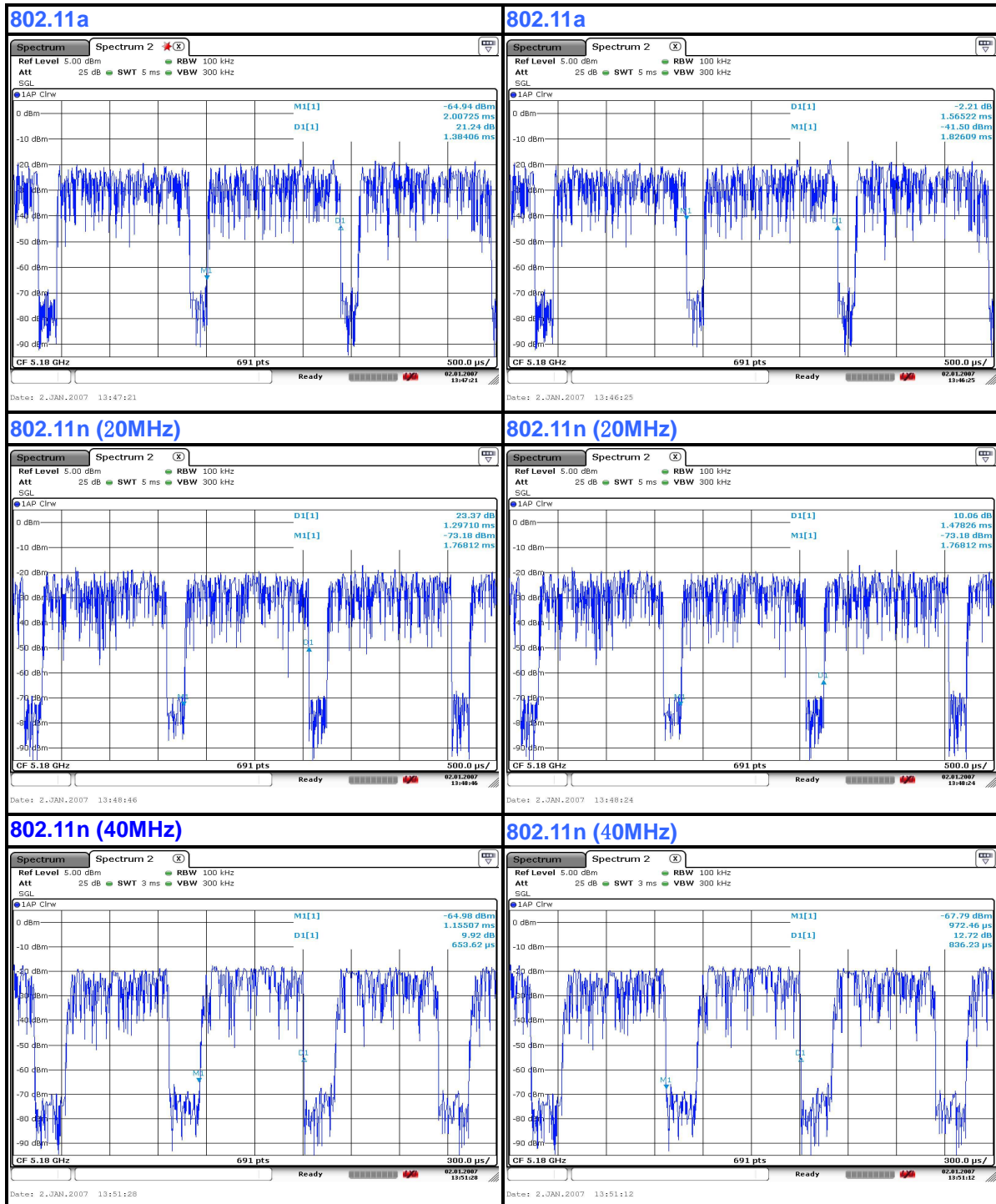



3.4 DESCRIPTION OF SUPPORT UNITS

The EUT has been tested as an independent unit together with other necessary accessories or support units. The following support units or accessories were used to form a representative test configuration during the tests.

NO.	PRODUCT	BRAND	MODEL NO.	SERIAL NO.	FCC ID
1	DC source	LONG WEI	PS-6403D	010934269	N/A
2	PC	HP	A6608CN	3CR83825X3	N/A
3	Earphone	Minami	ME-816B5-E	N/A	N/A

NO.	SIGNAL CABLE DESCRIPTION OF THE ABOVE SUPPORT UNITS
1	DC Line: Unshielded, Detachable 1.0m
2	AC Line: Unshielded, Detachable 1.5m
3	DC Line: Unshielded, Detachable 1.2m

NOTE:

1. All power cords of the above support units are non shielded (1.8m).



3.4.1 CONFIGURATION OF SYSTEM UNDER TEST

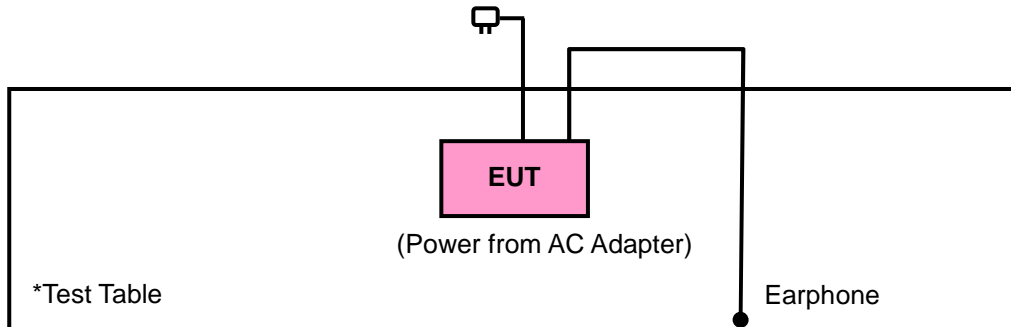

3.5 GENERAL DESCRIPTION OF APPLIED STANDARDS

The EUT is a RF Product. According to the specifications of the manufacturer, it must comply with the requirements of the following standards:

FCC Part 15, Subpart E (15.407)

KDB 905462 _Section 15.407 UNII Test Procedures

ANSI C63.10-2009

All test items have been performed and recorded as per the above standards.

NOTE: The EUT is also considered as a kind of computer peripheral, because the connection to computer is necessary for typical use. It has been verified to comply with the requirements of FCC Part 15, Subpart B, Class B (verification). The test report has been issued separately.



4. TEST TYPES AND RESULTS

4.1 RADIATED EMISSION AND BANDEDGE MEASUREMENT

4.1.1 LIMITS OF RADIATED EMISSION AND BANDEDGE MEASUREMENT

Radiated emissions which fall in the restricted bands must comply with the radiated emission limits specified as below table:

FREQUENCIES (MHz)	FIELD STRENGTH (microvolts/meter)	MEASUREMENT DISTANCE (meters)
0.009 ~ 0.490	2400/F(kHz)	300
0.490 ~ 1.705	24000/F(kHz)	30
1.705 ~ 30.0	30	30
30 ~ 88	100	3
88 ~ 216	150	3
216 ~ 960	200	3
Above 960	500	3

NOTE:

1. The lower limit shall apply at the transition frequencies.
2. Emission level (dBuV/m) = 20 log Emission level (uV/m).
3. For frequencies above 1000MHz, the field strength limits are based on average detector, however, the peak field strength of any emission shall not exceed the maximum permitted average limits, specified above by more than 20dB under any condition of modulation.

4.1.2 LIMITS OF UNWANTED EMISSION OUT OF THE RESTRICTED BANDS

APPLICABLE TO	LIMIT	
	FIELD STRENGTH AT 3m (dBµV/m)	
	PK	AV
	74	54
√	EIRP LIMIT (dBm)	
	PK	PK
	-27	68.3

NOTE: The following formula is used to convert the equipment isotropic radiated power (eirp) to field strength:

$$E = \frac{1000000\sqrt{30P}}{3} \mu\text{V/m, where P is the eirp (Watts).}$$



4.1.3 TEST INSTRUMENTS

Equipment	Manufacturer	Model No.	Serial No.	Last Cal.	Next Cal.
Spectrum Analyzer	Agilent	E4446A	MY46180622	Apr. 29,14	Apr. 28,15
EMI Test Receiver	Rohde&Schwarz	ESVS10	841431/004	May 17,14	May 16,15
Loop antenna (9kHz~30MHz)	Daze	ZN30900A	0708	Dec. 05,13	Dec. 04,14
Bilog Antenna (20MHz -2GHz)	Teseq	CBL 6111D	27089	Jul. 27, 14	Jul. 26, 15
Horn Antenna (1GHz -18GHz)	ETS -Lindgren	3117	00062558	May 30,14	May 29,16
Horn Antenna (18GHz-40GHz)	SCHWARZBECK	BBHA 9170	BBHA9170242	Feb. 13,14	Feb. 12,17
Pre-Amplifier (9kHz~1GHz)	SONOMA	310D	186955	Mar. 05,14	Mar. 04,15
Signal Amplifier	Agilent	8447D	2944A10488	Jun. 25,14	Jun. 24,15
Pre-Amplifier (100MHz-26.5GHz)	Agilent	8449B	3008A00409	May 13,14	May 12,15
Pre-Amplifier (18GHz-40GHz)	EMCI	EMC 184045	980102	Nov. 04,13	Nov. 03,14
3m Semi-anechoic Chamber	ETS-LINDGREN	9m*6m*6m	NSEMC003	Jul. 27,14	Jul. 26, 15
Test Software	ADT	ADT_Radiated _V7.6.15.9.2	N/A	N/A	N/A

NOTE:

1. The calibration interval of the above test instruments is 12 months and the calibrations are traceable to CEPREI/CHINA, GRGT/CHINA and NIM/CHINA.
2. The test was performed in 966 Chamber.
3. The FCC Site Registration No. is 502831.



4.1.4 TEST PROCEDURES

- a. The EUT was placed on the top of a rotating table 0.8 meters above the ground at a 3 meter semi-anechoic chamber. The table was rotated 360 degrees to determine the position of the highest radiation.
- b. The EUT was set 3 meters away from the interference-receiving antenna, which was mounted on the top of a variable-height antenna tower.
- c. The antenna is a broadband antenna, and its height is varied from one meter to four meters above the ground to determine the maximum value of the field strength. Both horizontal and vertical polarizations of the antenna are set to make the measurement.
- d. For each suspected emission, the EUT was arranged to its worst case and then the antenna was tuned to heights from 1 meter to 4 meters and the rotatable table was turned from 0 degrees to 360 degrees to find the maximum reading.
- e. The test-receiver system was set to Peak Detect Function and Specified Bandwidth with Maximum Hold Mode.
- f. If the emission level of the EUT in peak mode was 10dB lower than the limit specified, then testing could be stopped and the peak values of the EUT would be reported. Otherwise the emissions that did not have 10dB margin would be re-tested one by one using peak, quasi-peak or average method as specified and then reported in a data sheet.

NOTE:

1. The resolution bandwidth and video bandwidth of test receiver/spectrum analyzer is 120kHz for Peak detection (PK) and Quasi-peak detection (QP) at frequency below 1GHz.
2. The resolution bandwidth of test receiver/spectrum analyzer is 1MHz and video bandwidth is 3MHz for Peak detection at frequency above 1GHz.
3. The resolution bandwidth of test receiver/spectrum analyzer is 1MHz and the video bandwidth is 10Hz for Average detection (AV) at frequency above 1GHz.
4. All modes of operation were investigated and the worst-case emissions are reported.

4.1.5 DEVIATION FROM TEST STANDARD

No deviation.



4.1.6 TEST SETUP

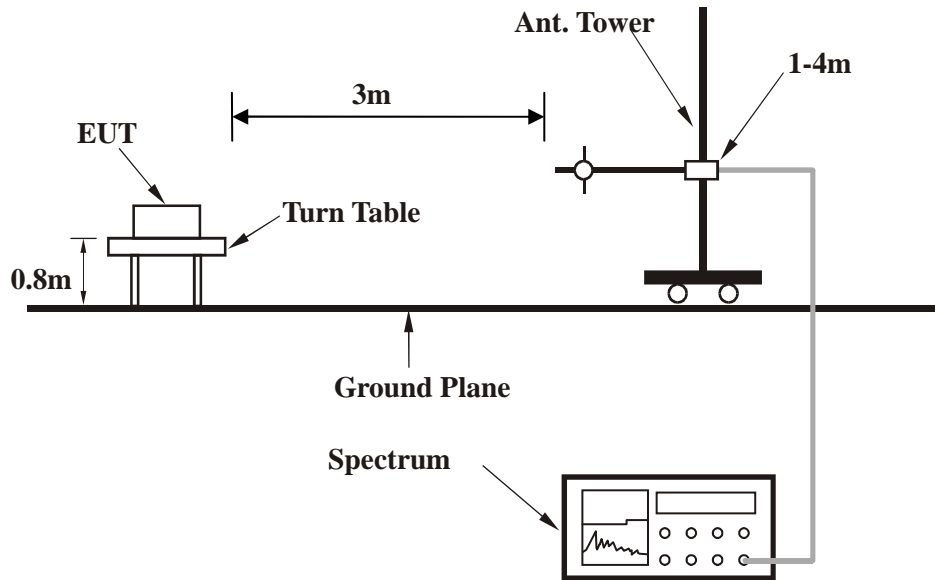

For the actual test configuration, please refer to the attached file (Test Setup Photo).

4.1.7 EUT OPERATING CONDITION

- Set the EUT under full load condition and placed them on a testing table.
- Set the transmitter part of EUT under transmission condition continuously at specific channel frequency.
- The necessary accessories enable the EUT in full functions.



4.1.8 TEST RESULTS

BELOW 1GHz WORST-CASE DATA:

802.11a

CHANNEL	Channel 36	DETECTOR FUNCTION	Quasi-Peak (QP)
FREQUENCY RANGE	30MHz ~ 1GHz		

ANTENNA POLARITY & TEST DISTANCE: HORIZONTAL AT 3 M								
NO.	FREQ. (MHz)	EMISSION LEVEL (dBuV/m)	LIMIT (dBuV/m)	MARGIN (dB)	ANTENNA HEIGHT (m)	TABLE ANGLE (Degree)	RAW VALUE (dBuV)	CORRECTION FACTOR (dB/m)
1	30.00	14.0 QP	40.0	-26.0	1.00 H	0	-5.64	19.65
2	135.08	16.8 QP	43.5	-26.7	1.00 H	0	3.11	13.69
3	180.35	13.0 QP	43.5	-30.5	1.00 H	0	1.46	11.55
4	345.25	32.4 QP	46.0	-13.6	1.00 H	0	14.40	18.03
5	416.38	36.2 QP	46.0	-9.8	1.00 H	0	15.78	20.42
6	460.03	32.7 QP	46.0	-13.3	1.00 H	0	11.81	20.88

REMARKS:

1. Emission level (dBuV/m) = Raw Value (dBuV) + Correction Factor (dB/m).
2. Correction Factor (dB/m) = Antenna Factor (dB/m) + Cable Factor (dB).
3. The other emission levels were very low against the limit.
4. Margin value = Emission level – Limit value.

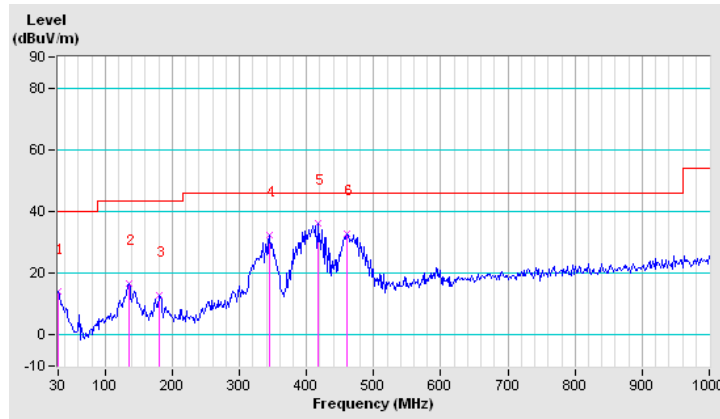



CHANNEL	Channel 36	DETECTOR FUNCTION	Quasi-Peak (QP)
FREQUENCY RANGE	30MHz ~ 1GHz		

ANTENNA POLARITY & TEST DISTANCE: VERTICAL AT 3 M								
NO.	FREQ. (MHz)	EMISSION LEVEL (dBuV/m)	LIMIT (dBuV/m)	MARGIN (dB)	ANTENNA HEIGHT (m)	TABLE ANGLE (Degree)	RAW VALUE (dBuV)	CORRECTION FACTOR (dB/m)
1	30.00	34.7 QP	40.0	-5.3	1.00 V	0	15.09	19.65
2	135.08	20.5 QP	43.5	-23.0	1.00 V	0	6.80	13.69
3	173.88	18.7 QP	43.5	-24.9	1.00 V	0	7.22	11.43
4	345.25	34.0 QP	46.0	-12.0	1.00 V	0	15.98	18.03
5	416.38	41.9 QP	46.0	-4.1	1.00 V	0	21.47	20.42
6	586.13	28.5 QP	46.0	-17.5	1.00 V	0	4.53	23.94

REMARKS:

1. Emission level (dBuV/m) = Raw Value (dBuV) + Correction Factor (dB/m).
2. Correction Factor (dB/m) = Antenna Factor (dB/m) + Cable Factor (dB).
3. The other emission levels were very low against the limit.
4. Margin value = Emission level – Limit value.

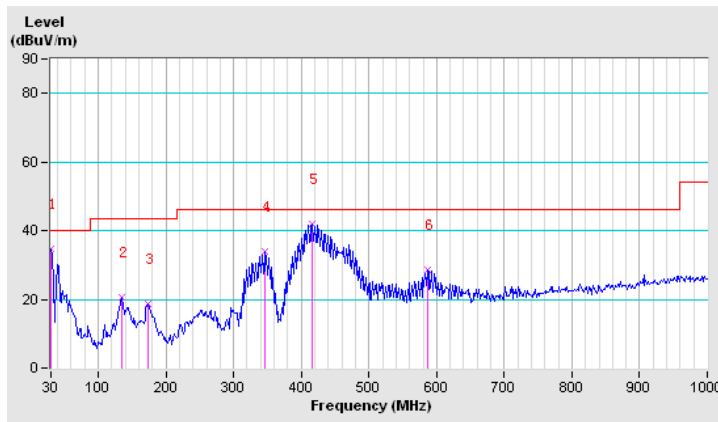



ABOVE 1GHz WORST-CASE DATA: Band 1

802.11a

CHANNEL	TX Channel 36	DETECTOR FUNCTION	Peak (PK)
FREQUENCY RANGE	1GHz ~ 40GHz		Average (AV)

ANTENNA POLARITY & TEST DISTANCE: HORIZONTAL AT 3 M								
NO.	FREQ. (MHz)	EMISSION LEVEL (dBuV/m)	LIMIT (dBuV/m)	MARGIN (dB)	ANTENNA HEIGHT (m)	TABLE ANGLE (Degree)	RAW VALUE (dBuV)	CORRECTION FACTOR (dB/m)
1	5150.00	52.3 PK	74.0	-21.7	1.21 H	252	12.32	39.98
2	5150.00	40.2 AV	54.0	-13.8	1.21 H	252	0.22	39.98
3	*5180.00	95.6 PK			1.21 H	252	55.56	40.04
4	*5180.00	78.8 AV			1.21 H	252	38.76	40.04
5	#10360.00	52.8 PK	74.0	-21.2	1.00 H	360	6.36	46.44
6	#10360.00	39.7 AV	54.0	-14.3	1.00 H	360	-6.74	46.44
ANTENNA POLARITY & TEST DISTANCE: VERTICAL AT 3 M								
NO.	FREQ. (MHz)	EMISSION LEVEL (dBuV/m)	LIMIT (dBuV/m)	MARGIN (dB)	ANTENNA HEIGHT (m)	TABLE ANGLE (Degree)	RAW VALUE (dBuV)	CORRECTION FACTOR (dB/m)
1	5150.00	56.3 PK	74.0	-17.7	1.25 V	90	16.32	39.98
2	5150.00	41.0 AV	54.0	-13.0	1.25 V	90	1.02	39.98
3	*5180.00	105.1 PK			1.25 V	90	65.06	40.04
4	*5180.00	87.0 AV			1.25 V	90	46.96	40.04
5	#10360.00	53.7 PK	74.0	-20.3	1.00 V	0	7.26	46.44
6	#10360.00	39.3 AV	54.0	-14.7	1.00 V	0	-7.14	46.44

REMARKS:

1. Emission level (dBuV/m) = Raw Value (dBuV) + Correction Factor (dB/m).
2. Correction Factor (dB/m) = Antenna Factor (dB/m) + Cable Factor (dB).
3. The other emission levels were very low against the limit.
4. Margin value = Emission level – Limit value.
5. " * ": Fundamental frequency.
6. " # ": The radiated frequency is out of the restricted band.



CHANNEL	TX Channel 44	DETECTOR FUNCTION	Peak (PK)
FREQUENCY RANGE	1GHz ~ 40GHz		Average (AV)

ANTENNA POLARITY & TEST DISTANCE: HORIZONTAL AT 3 M

NO.	FREQ. (MHz)	EMISSION LEVEL (dBuV/m)	LIMIT (dBuV/m)	MARGIN (dB)	ANTENNA HEIGHT (m)	TABLE ANGLE (Degree)	RAW VALUE (dBuV)	CORRECTION FACTOR (dB/m)
1	*5220.00	96.3 PK			1.20 H	251	56.19	40.11
2	*5220.00	79.5 AV			1.20 H	251	39.39	40.11
3	#10440.00	51.6 PK	74.0	-22.4	1.00 H	175	4.99	46.61
4	#10440.00	38.8 AV	54.0	-15.2	1.00 H	175	-7.81	46.61

ANTENNA POLARITY & TEST DISTANCE: VERTICAL AT 3 M

NO.	FREQ. (MHz)	EMISSION LEVEL (dBuV/m)	LIMIT (dBuV/m)	MARGIN (dB)	ANTENNA HEIGHT (m)	TABLE ANGLE (Degree)	RAW VALUE (dBuV)	CORRECTION FACTOR (dB/m)
1	*5220.00	105.5 PK			1.26 V	89	65.39	40.11
2	*5220.00	88.2 AV			1.26 V	89	48.09	40.11
3	#10440.00	52.5 PK	74.0	-21.5	1.00 V	231	5.89	46.61
4	#10440.00	38.9 AV	54.0	-15.1	1.00 V	231	-7.71	46.61

REMARKS:

1. Emission level (dBuV/m) = Raw Value (dBuV) + Correction Factor (dB/m).
2. Correction Factor (dB/m) = Antenna Factor (dB/m) + Cable Factor (dB).
3. The other emission levels were very low against the limit.
4. Margin value = Emission level – Limit value.
5. " * ": Fundamental frequency.
6. " # ": The radiated frequency is out of the restricted band.



CHANNEL	TX Channel 48	DETECTOR FUNCTION	Peak (PK)
FREQUENCY RANGE	1GHz ~ 40GHz		Average (AV)

ANTENNA POLARITY & TEST DISTANCE: HORIZONTAL AT 3 M								
NO.	FREQ. (MHz)	EMISSION LEVEL (dBuV/m)	LIMIT (dBuV/m)	MARGIN (dB)	ANTENNA HEIGHT (m)	TABLE ANGLE (Degree)	RAW VALUE (dBuV)	CORRECTION FACTOR (dB/m)
1	*5240.00	96.5 PK			1.35 H	249	56.36	40.14
2	*5240.00	79.3 AV			1.35 H	249	39.16	40.14
3	#10480.00	53.0 PK	74.0	-21.0	1.21 H	177	6.31	46.69
4	#10480.00	38.2 AV	54.0	-15.8	1.21 H	177	-8.49	46.69
ANTENNA POLARITY & TEST DISTANCE: VERTICAL AT 3 M								
NO.	FREQ. (MHz)	EMISSION LEVEL (dBuV/m)	LIMIT (dBuV/m)	MARGIN (dB)	ANTENNA HEIGHT (m)	TABLE ANGLE (Degree)	RAW VALUE (dBuV)	CORRECTION FACTOR (dB/m)
1	*5240.00	105.7 PK			1.24 V	77	65.56	40.14
2	*5240.00	88.6 AV			1.24 V	77	48.46	40.14
3	#10480.00	52.2 PK	74.0	-21.8	1.31 V	215	5.51	46.69
4	#10480.00	38.7 AV	54.0	-15.3	1.31 V	215	-7.99	46.69

REMARKS:

1. Emission level (dBuV/m) = Raw Value (dBuV) + Correction Factor (dB/m).
2. Correction Factor (dB/m) = Antenna Factor (dB/m) + Cable Factor (dB).
3. The other emission levels were very low against the limit.
4. Margin value = Emission level – Limit value.
5. " * ": Fundamental frequency.
6. " # ": The radiated frequency is out of the restricted band.



802.11n (20MHz)

CHANNEL	TX Channel 36	DETECTOR FUNCTION	Peak (PK)
FREQUENCY RANGE	1GHz ~ 40GHz		Average (AV)

ANTENNA POLARITY & TEST DISTANCE: HORIZONTAL AT 3 M								
NO.	FREQ. (MHz)	EMISSION LEVEL (dBuV/m)	LIMIT (dBuV/m)	MARGIN (dB)	ANTENNA HEIGHT (m)	TABLE ANGLE (Degree)	RAW VALUE (dBuV)	CORRECTION FACTOR (dB/m)
1	5150.00	52.0 PK	74.0	-22.0	1.23 H	252	12.02	39.98
2	5150.00	40.2 AV	54.0	-13.8	1.23 H	252	0.22	39.98
3	*5180.00	94.1 PK			1.23 H	252	54.06	40.04
4	*5180.00	78.0 AV			1.23 H	252	37.96	40.04
5	#10360.00	53.0 PK	74.0	-21.0	1.25 H	244	6.56	46.44
6	#10360.00	40.0 AV	54.0	-14.0	1.25 H	244	-6.44	46.44
ANTENNA POLARITY & TEST DISTANCE: VERTICAL AT 3 M								
NO.	FREQ. (MHz)	EMISSION LEVEL (dBuV/m)	LIMIT (dBuV/m)	MARGIN (dB)	ANTENNA HEIGHT (m)	TABLE ANGLE (Degree)	RAW VALUE (dBuV)	CORRECTION FACTOR (dB/m)
1	5150.00	58.1 PK	74.0	-15.9	1.14 V	89	18.12	39.98
2	5150.00	42.7 AV	54.0	-11.3	1.14 V	89	2.72	39.98
3	*5180.00	105.9 PK			1.14 V	89	65.86	40.04
4	*5180.00	87.6 AV			1.14 V	89	47.56	40.04
5	#10360.00	53.5 PK	74.0	-20.5	1.20 V	78	7.06	46.44
6	#10360.00	39.9 AV	54.0	-14.1	1.20 V	78	-6.54	46.44

REMARKS:

1. Emission level (dBuV/m) = Raw Value (dBuV) + Correction Factor (dB/m).
2. Correction Factor (dB/m) = Antenna Factor (dB/m) + Cable Factor (dB).
3. The other emission levels were very low against the limit.
4. Margin value = Emission level – Limit value.
5. " * ": Fundamental frequency.
6. " # ": The radiated frequency is out of the restricted band.



CHANNEL	TX Channel 44	DETECTOR FUNCTION	Peak (PK)
FREQUENCY RANGE	1GHz ~ 40GHz		Average (AV)

ANTENNA POLARITY & TEST DISTANCE: HORIZONTAL AT 3 M

NO.	FREQ. (MHz)	EMISSION LEVEL (dBuV/m)	LIMIT (dBuV/m)	MARGIN (dB)	ANTENNA HEIGHT (m)	TABLE ANGLE (Degree)	RAW VALUE (dBuV)	CORRECTION FACTOR (dB/m)
1	*5220.00	95.1 PK			1.20 H	250	54.99	40.11
2	*5220.00	78.1 AV			1.20 H	250	37.99	40.11
3	#10440.00	51.9 PK	74.0	-22.1	1.25 H	268	5.29	46.61
4	#10440.00	38.5 AV	54.0	-15.5	1.25 H	268	-8.11	46.61

ANTENNA POLARITY & TEST DISTANCE: VERTICAL AT 3 M

NO.	FREQ. (MHz)	EMISSION LEVEL (dBuV/m)	LIMIT (dBuV/m)	MARGIN (dB)	ANTENNA HEIGHT (m)	TABLE ANGLE (Degree)	RAW VALUE (dBuV)	CORRECTION FACTOR (dB/m)
1	*5220.00	103.3 PK			1.14 V	90	63.19	40.11
2	*5220.00	85.1 AV			1.14 V	90	44.99	40.11
3	#10440.00	51.7 PK	74.0	-22.3	1.17 V	109	5.09	46.61
4	#10440.00	38.1 AV	54.0	-15.9	1.17 V	109	-8.51	46.61

REMARKS:

1. Emission level (dBuV/m) = Raw Value (dBuV) + Correction Factor (dB/m).
2. Correction Factor (dB/m) = Antenna Factor (dB/m) + Cable Factor (dB).
3. The other emission levels were very low against the limit.
4. Margin value = Emission level – Limit value.
5. " * ": Fundamental frequency.
6. " # ": The radiated frequency is out of the restricted band.



CHANNEL	TX Channel 48	DETECTOR FUNCTION	Peak (PK)
FREQUENCY RANGE	1GHz ~ 40GHz		Average (AV)

ANTENNA POLARITY & TEST DISTANCE: HORIZONTAL AT 3 M

NO.	FREQ. (MHz)	EMISSION LEVEL (dBuV/m)	LIMIT (dBuV/m)	MARGIN (dB)	ANTENNA HEIGHT (m)	TABLE ANGLE (Degree)	RAW VALUE (dBuV)	CORRECTION FACTOR (dB/m)
1	*5240.00	94.3 PK			1.22 H	251	54.16	40.14
2	*5240.00	76.8 AV			1.22 H	251	36.66	40.14
3	#10480.00	51.5 PK	74.0	-22.5	1.23 H	266	4.81	46.69
4	#10480.00	37.7 AV	54.0	-16.3	1.23 H	266	-8.99	46.69

ANTENNA POLARITY & TEST DISTANCE: VERTICAL AT 3 M

NO.	FREQ. (MHz)	EMISSION LEVEL (dBuV/m)	LIMIT (dBuV/m)	MARGIN (dB)	ANTENNA HEIGHT (m)	TABLE ANGLE (Degree)	RAW VALUE (dBuV)	CORRECTION FACTOR (dB/m)
1	*5240.00	102.9 PK			1.22 V	81	62.76	40.14
2	*5240.00	85.5 AV			1.22 V	81	45.36	40.14
3	#10480.00	51.8 PK	74.0	-22.2	1.28 V	105	5.11	46.69
4	#10480.00	37.4 AV	54.0	-16.6	1.28 V	105	-9.29	46.69

REMARKS:

1. Emission level (dBuV/m) = Raw Value (dBuV) + Correction Factor (dB/m).
2. Correction Factor (dB/m) = Antenna Factor (dB/m) + Cable Factor (dB).
3. The other emission levels were very low against the limit.
4. Margin value = Emission level – Limit value.
5. " * ": Fundamental frequency.
6. " # ": The radiated frequency is out of the restricted band.



802.11n (40MHz)

CHANNEL	TX Channel 38	DETECTOR FUNCTION	Peak (PK)
FREQUENCY RANGE	1GHz ~ 40GHz		Average (AV)

ANTENNA POLARITY & TEST DISTANCE: HORIZONTAL AT 3 M								
NO.	FREQ. (MHz)	EMISSION LEVEL (dBuV/m)	LIMIT (dBuV/m)	MARGIN (dB)	ANTENNA HEIGHT (m)	TABLE ANGLE (Degree)	RAW VALUE (dBuV)	CORRECTION FACTOR (dB/m)
1	5150.00	57.7 PK	74.0	-16.3	1.23 H	256	17.72	39.98
2	5150.00	41.4 AV	54.0	-12.6	1.23 H	256	1.42	39.98
3	*5190.00	92.0 PK			1.23 H	256	51.95	40.05
4	*5190.00	70.4 AV			1.23 H	256	30.35	40.05
5	#10380.00	52.4 PK	74.0	-21.6	1.18 H	276	5.92	46.48
6	#10380.00	38.5 AV	54.0	-15.5	1.18 H	276	-7.98	46.48
ANTENNA POLARITY & TEST DISTANCE: VERTICAL AT 3 M								
NO.	FREQ. (MHz)	EMISSION LEVEL (dBuV/m)	LIMIT (dBuV/m)	MARGIN (dB)	ANTENNA HEIGHT (m)	TABLE ANGLE (Degree)	RAW VALUE (dBuV)	CORRECTION FACTOR (dB/m)
1	5150.00	66.1 PK	74.0	-7.9	1.15 V	91	26.12	39.98
2	5150.00	47.4 AV	54.0	-6.6	1.15 V	91	7.42	39.98
3	*5190.00	102.4 PK			1.15 V	91	62.35	40.05
4	*5190.00	78.4 AV			1.15 V	91	38.35	40.05
5	#10380.00	53.0 PK	74.0	-21.0	1.10 V	78	6.52	46.48
6	#10380.00	38.6 AV	54.0	-15.4	1.10 V	78	-7.88	46.48

REMARKS:

1. Emission level (dBuV/m) = Raw Value (dBuV) + Correction Factor (dB/m).
2. Correction Factor (dB/m) = Antenna Factor (dB/m) + Cable Factor (dB).
3. The other emission levels were very low against the limit.
4. Margin value = Emission level – Limit value.
5. " * ": Fundamental frequency.
6. " # ": The radiated frequency is out of the restricted band.



CHANNEL	TX Channel 46	DETECTOR FUNCTION	Peak (PK)
FREQUENCY RANGE	1GHz ~ 40GHz		Average (AV)

ANTENNA POLARITY & TEST DISTANCE: HORIZONTAL AT 3 M								
NO.	FREQ. (MHz)	EMISSION LEVEL (dBuV/m)	LIMIT (dBuV/m)	MARGIN (dB)	ANTENNA HEIGHT (m)	TABLE ANGLE (Degree)	RAW VALUE (dBuV)	CORRECTION FACTOR (dB/m)
1	*5230.00	91.8 PK			1.34 H	246	51.68	40.12
2	*5230.00	70.8 AV			1.34 H	246	30.68	40.12
3	#10460.00	52.0 PK	74.0	-22.0	1.22 H	288	5.35	46.65
4	#10460.00	37.6 AV	54.0	-16.4	1.22 H	288	-9.05	46.65
ANTENNA POLARITY & TEST DISTANCE: VERTICAL AT 3 M								
NO.	FREQ. (MHz)	EMISSION LEVEL (dBuV/m)	LIMIT (dBuV/m)	MARGIN (dB)	ANTENNA HEIGHT (m)	TABLE ANGLE (Degree)	RAW VALUE (dBuV)	CORRECTION FACTOR (dB/m)
1	*5230.00	101.9 PK			1.04 V	136	61.78	40.12
2	*5230.00	78.5 AV			1.04 V	136	38.38	40.12
3	#10460.00	51.2 PK	74.0	-22.8	1.08 V	155	4.55	46.65
4	#10460.00	37.5 AV	54.0	-16.5	1.08 V	155	-9.15	46.65

REMARKS:

1. Emission level (dBuV/m) = Raw Value (dBuV) + Correction Factor (dB/m).
2. Correction Factor (dB/m) = Antenna Factor (dB/m) + Cable Factor (dB).
3. The other emission levels were very low against the limit.
4. Margin value = Emission level – Limit value.
5. " * ": Fundamental frequency.
6. " # ": The radiated frequency is out of the restricted band.



ABOVE 1GHz WORST-CASE DATA: Band 2

802.11a

CHANNEL	TX Channel 52	DETECTOR FUNCTION	Peak (PK)
FREQUENCY RANGE	1GHz ~ 40GHz		Average (AV)

ANTENNA POLARITY & TEST DISTANCE: HORIZONTAL AT 3 M

NO.	FREQ. (MHz)	EMISSION LEVEL (dBuV/m)	LIMIT (dBuV/m)	MARGIN (dB)	ANTENNA HEIGHT (m)	TABLE ANGLE (Degree)	RAW VALUE (dBuV)	CORRECTION FACTOR (dB/m)
1	*5260.00	94.7 PK			1.21 H	247	54.52	40.18
2	*5260.00	78.3 AV			1.21 H	247	38.12	40.18
3	#10520.00	52.3 PK	74.0	-21.7	1.25 H	279	5.55	46.75
4	#10520.00	38.6 AV	54.0	-15.4	1.25 H	279	-8.15	46.75

ANTENNA POLARITY & TEST DISTANCE: VERTICAL AT 3 M

NO.	FREQ. (MHz)	EMISSION LEVEL (dBuV/m)	LIMIT (dBuV/m)	MARGIN (dB)	ANTENNA HEIGHT (m)	TABLE ANGLE (Degree)	RAW VALUE (dBuV)	CORRECTION FACTOR (dB/m)
1	*5260.00	102.8 PK			1.23 V	91	62.62	40.18
2	*5260.00	84.8 AV			1.23 V	91	44.62	40.18
3	#10520.00	51.6 PK	74.0	-22.4	1.25 V	113	4.85	46.75
4	#10520.00	38.6 AV	54.0	-15.4	1.25 V	113	-8.15	46.75

REMARKS:

1. Emission level (dBuV/m) = Raw Value (dBuV) + Correction Factor (dB/m).
2. Correction Factor (dB/m) = Antenna Factor (dB/m) + Cable Factor (dB).
3. The other emission levels were very low against the limit.
4. Margin value = Emission level – Limit value.
5. " * ": Fundamental frequency.
6. " # ": The radiated frequency is out of the restricted band.



CHANNEL	TX Channel 60	DETECTOR FUNCTION	Peak (PK)
FREQUENCY RANGE	1GHz ~ 40GHz		Average (AV)

ANTENNA POLARITY & TEST DISTANCE: HORIZONTAL AT 3 M								
NO.	FREQ. (MHz)	EMISSION LEVEL (dBuV/m)	LIMIT (dBuV/m)	MARGIN (dB)	ANTENNA HEIGHT (m)	TABLE ANGLE (Degree)	RAW VALUE (dBuV)	CORRECTION FACTOR (dB/m)
1	*5300.00	93.1 PK			1.32 H	246	52.85	40.25
2	*5300.00	77.5 AV			1.32 H	246	37.25	40.25
3	10600.00	52.7 PK	74.0	-21.3	1.14 H	288	5.86	46.84
4	10600.00	37.6 AV	54.0	-16.4	1.14 H	288	-9.24	46.84
ANTENNA POLARITY & TEST DISTANCE: VERTICAL AT 3 M								
NO.	FREQ. (MHz)	EMISSION LEVEL (dBuV/m)	LIMIT (dBuV/m)	MARGIN (dB)	ANTENNA HEIGHT (m)	TABLE ANGLE (Degree)	RAW VALUE (dBuV)	CORRECTION FACTOR (dB/m)
1	*5300.00	102.3 PK			1.23 V	94	62.05	40.25
2	*5300.00	85.4 AV			1.23 V	94	45.15	40.25
3	10600.00	53.1 PK	74.0	-20.9	1.33 V	101	6.26	46.84
4	10600.00	38.2 AV	54.0	-15.8	1.33 V	101	-8.64	46.84

REMARKS:

1. Emission level (dBuV/m) = Raw Value (dBuV) + Correction Factor (dB/m).
2. Correction Factor (dB/m) = Antenna Factor (dB/m) + Cable Factor (dB).
3. The other emission levels were very low against the limit.
4. Margin value = Emission level – Limit value.
5. " * ": Fundamental frequency.



CHANNEL	TX Channel 64	DETECTOR FUNCTION	Peak (PK)
FREQUENCY RANGE	1GHz ~ 40GHz		Average (AV)

ANTENNA POLARITY & TEST DISTANCE: HORIZONTAL AT 3 M								
NO.	FREQ. (MHz)	EMISSION LEVEL (dBuV/m)	LIMIT (dBuV/m)	MARGIN (dB)	ANTENNA HEIGHT (m)	TABLE ANGLE (Degree)	RAW VALUE (dBuV)	CORRECTION FACTOR (dB/m)
1	*5320.00	94.3 PK			1.20 H	253	54.02	40.28
2	*5320.00	77.8 AV			1.20 H	253	37.52	40.28
3	5350.00	53.1 PK	74.0	-20.9	1.20 H	253	12.76	40.34
4	5350.00	41.2 AV	54.0	-12.8	1.20 H	253	0.86	40.34
5	10640.00	51.3 PK	74.0	-22.7	1.24 H	268	4.42	46.88
6	10640.00	38.4 AV	54.0	-15.6	1.24 H	268	-8.48	46.88
ANTENNA POLARITY & TEST DISTANCE: VERTICAL AT 3 M								
NO.	FREQ. (MHz)	EMISSION LEVEL (dBuV/m)	LIMIT (dBuV/m)	MARGIN (dB)	ANTENNA HEIGHT (m)	TABLE ANGLE (Degree)	RAW VALUE (dBuV)	CORRECTION FACTOR (dB/m)
1	*5320.00	104.6 PK			1.23 V	91	64.32	40.28
2	*5320.00	86.4 AV			1.23 V	91	46.12	40.28
3	5350.00	55.8 PK	74.0	-18.2	1.23 V	91	15.46	40.34
4	5350.00	42.2 AV	54.0	-11.8	1.23 V	91	1.86	40.34
5	10640.00	51.8 PK	74.0	-22.2	1.00 V	360	4.92	46.88
6	10640.00	38.5 AV	54.0	-15.5	1.00 V	360	-8.38	46.88

REMARKS:

1. Emission level (dBuV/m) = Raw Value (dBuV) + Correction Factor (dB/m).
2. Correction Factor (dB/m) = Antenna Factor (dB/m) + Cable Factor (dB).
3. The other emission levels were very low against the limit.
4. Margin value = Emission level – Limit value.
5. " * ": Fundamental frequency.



802.11n (20MHz)

CHANNEL	TX Channel 52	DETECTOR FUNCTION	Peak (PK)
FREQUENCY RANGE	1GHz ~ 40GHz		Average (AV)

ANTENNA POLARITY & TEST DISTANCE: HORIZONTAL AT 3 M								
NO.	FREQ. (MHz)	EMISSION LEVEL (dBuV/m)	LIMIT (dBuV/m)	MARGIN (dB)	ANTENNA HEIGHT (m)	TABLE ANGLE (Degree)	RAW VALUE (dBuV)	CORRECTION FACTOR (dB/m)
1	*5260.00	93.6 PK			1.09 H	260	53.42	40.18
2	*5260.00	77.1 AV			1.09 H	260	36.92	40.18
3	#10520.00	52.4 PK	74.0	-21.6	1.18 H	289	5.65	46.75
4	#10520.00	38.5 AV	54.0	-15.5	1.18 H	289	-8.25	46.75

ANTENNA POLARITY & TEST DISTANCE: VERTICAL AT 3 M								
NO.	FREQ. (MHz)	EMISSION LEVEL (dBuV/m)	LIMIT (dBuV/m)	MARGIN (dB)	ANTENNA HEIGHT (m)	TABLE ANGLE (Degree)	RAW VALUE (dBuV)	CORRECTION FACTOR (dB/m)
1	*5260.00	104.7 PK			1.25 V	95	64.52	40.18
2	*5260.00	86.7 AV			1.25 V	95	46.52	40.18
3	#10520.00	52.1 PK	74.0	-21.9	1.21 V	90	5.35	46.75
4	#10520.00	38.2 AV	54.0	-15.8	1.21 V	90	-8.55	46.75

REMARKS:

1. Emission level (dBuV/m) = Raw Value (dBuV) + Correction Factor (dB/m).
2. Correction Factor (dB/m) = Antenna Factor (dB/m) + Cable Factor (dB).
3. The other emission levels were very low against the limit.
4. Margin value = Emission level – Limit value.
5. " * ": Fundamental frequency.
6. " # ": The radiated frequency is out of the restricted band.



CHANNEL	TX Channel 60	DETECTOR FUNCTION	Peak (PK)
FREQUENCY RANGE	1GHz ~ 40GHz		Average (AV)

ANTENNA POLARITY & TEST DISTANCE: HORIZONTAL AT 3 M

NO.	FREQ. (MHz)	EMISSION LEVEL (dBuV/m)	LIMIT (dBuV/m)	MARGIN (dB)	ANTENNA HEIGHT (m)	TABLE ANGLE (Degree)	RAW VALUE (dBuV)	CORRECTION FACTOR (dB/m)
1	*5300.00	94.4 PK			1.20 H	256	54.15	40.25
2	*5300.00	77.3 AV			1.20 H	256	37.05	40.25
3	10600.00	51.8 PK	74.0	-22.2	1.23 H	231	4.96	46.84
4	10600.00	37.6 AV	54.0	-16.4	1.23 H	231	-9.24	46.84

ANTENNA POLARITY & TEST DISTANCE: VERTICAL AT 3 M

NO.	FREQ. (MHz)	EMISSION LEVEL (dBuV/m)	LIMIT (dBuV/m)	MARGIN (dB)	ANTENNA HEIGHT (m)	TABLE ANGLE (Degree)	RAW VALUE (dBuV)	CORRECTION FACTOR (dB/m)
1	*5300.00	105.4 PK			1.23 V	94	65.15	40.25
2	*5300.00	86.4 AV			1.23 V	94	46.15	40.25
3	10600.00	52.3 PK	74.0	-21.7	1.14 V	103	5.46	46.84
4	10600.00	37.9 AV	54.0	-16.1	1.14 V	103	-8.94	46.84

REMARKS:

1. Emission level (dBuV/m) = Raw Value (dBuV) + Correction Factor (dB/m).
2. Correction Factor (dB/m) = Antenna Factor (dB/m) + Cable Factor (dB).
3. The other emission levels were very low against the limit.
4. Margin value = Emission level – Limit value.
5. " * ": Fundamental frequency.



CHANNEL	TX Channel 64	DETECTOR FUNCTION	Peak (PK)
FREQUENCY RANGE	1GHz ~ 40GHz		Average (AV)

ANTENNA POLARITY & TEST DISTANCE: HORIZONTAL AT 3 M								
NO.	FREQ. (MHz)	EMISSION LEVEL (dBuV/m)	LIMIT (dBuV/m)	MARGIN (dB)	ANTENNA HEIGHT (m)	TABLE ANGLE (Degree)	RAW VALUE (dBuV)	CORRECTION FACTOR (dB/m)
1	*5320.00	93.9 PK			1.18 H	244	53.62	40.28
2	*5320.00	76.8 AV			1.18 H	244	36.52	40.28
3	5350.00	53.0 PK	74.0	-21.0	1.18 H	244	12.66	40.34
4	5350.00	40.8 AV	54.0	-13.2	1.18 H	244	0.46	40.34
5	10640.00	53.2 PK	74.0	-20.8	1.00 H	360	6.32	46.88
6	10640.00	38.4 AV	54.0	-15.6	1.00 H	360	-8.48	46.88
ANTENNA POLARITY & TEST DISTANCE: VERTICAL AT 3 M								
NO.	FREQ. (MHz)	EMISSION LEVEL (dBuV/m)	LIMIT (dBuV/m)	MARGIN (dB)	ANTENNA HEIGHT (m)	TABLE ANGLE (Degree)	RAW VALUE (dBuV)	CORRECTION FACTOR (dB/m)
1	*5320.00	105.1 PK			1.20 V	96	64.82	40.28
2	*5320.00	86.6 AV			1.20 V	96	46.32	40.28
3	5350.00	58.1 PK	74.0	-15.9	1.20 V	96	17.76	40.34
4	5350.00	42.5 AV	54.0	-11.5	1.20 V	96	2.16	40.34
5	10640.00	52.5 PK	74.0	-21.5	1.00 V	360	5.62	46.88
6	10640.00	37.6 AV	54.0	-16.4	1.00 V	360	-9.28	46.88

REMARKS:

1. Emission level (dBuV/m) = Raw Value (dBuV) + Correction Factor (dB/m).
2. Correction Factor (dB/m) = Antenna Factor (dB/m) + Cable Factor (dB).
3. The other emission levels were very low against the limit.
4. Margin value = Emission level – Limit value.
5. " * ": Fundamental frequency.



802.11n (40MHz)

CHANNEL	TX Channel 54	DETECTOR FUNCTION	Peak (PK)
FREQUENCY RANGE	1GHz ~ 40GHz		Average (AV)

ANTENNA POLARITY & TEST DISTANCE: HORIZONTAL AT 3 M								
NO.	FREQ. (MHz)	EMISSION LEVEL (dBuV/m)	LIMIT (dBuV/m)	MARGIN (dB)	ANTENNA HEIGHT (m)	TABLE ANGLE (Degree)	RAW VALUE (dBuV)	CORRECTION FACTOR (dB/m)
1	*5270.00	92.1 PK			1.22 H	255	51.90	40.20
2	*5270.00	70.7 AV			1.22 H	255	30.50	40.20
3	#10540.00	52.6 PK	74.0	-21.4	1.27 H	251	5.83	46.77
4	#10540.00	36.8 AV	54.0	-17.2	1.27 H	251	-9.97	46.77

ANTENNA POLARITY & TEST DISTANCE: VERTICAL AT 3 M								
NO.	FREQ. (MHz)	EMISSION LEVEL (dBuV/m)	LIMIT (dBuV/m)	MARGIN (dB)	ANTENNA HEIGHT (m)	TABLE ANGLE (Degree)	RAW VALUE (dBuV)	CORRECTION FACTOR (dB/m)
1	*5270.00	101.6 PK			1.21 V	70	61.40	40.20
2	*5270.00	78.2 AV			1.21 V	70	38.00	40.20
3	#10540.00	51.4 PK	74.0	-22.6	1.14 V	125	4.63	46.77
4	#10540.00	36.8 AV	54.0	-17.2	1.14 V	125	-9.97	46.77

REMARKS:

1. Emission level (dBuV/m) = Raw Value (dBuV) + Correction Factor (dB/m).
2. Correction Factor (dB/m) = Antenna Factor (dB/m) + Cable Factor (dB).
3. The other emission levels were very low against the limit.
4. Margin value = Emission level – Limit value.
5. " * ": Fundamental frequency.
6. " # ": The radiated frequency is out of the restricted band.



CHANNEL	TX Channel 62	DETECTOR FUNCTION	Peak (PK)
FREQUENCY RANGE	1GHz ~ 40GHz		Average (AV)

ANTENNA POLARITY & TEST DISTANCE: HORIZONTAL AT 3 M								
NO.	FREQ. (MHz)	EMISSION LEVEL (dBuV/m)	LIMIT (dBuV/m)	MARGIN (dB)	ANTENNA HEIGHT (m)	TABLE ANGLE (Degree)	RAW VALUE (dBuV)	CORRECTION FACTOR (dB/m)
1	*5310.00	91.0 PK			1.19 H	249	50.73	40.27
2	*5310.00	70.2 AV			1.19 H	249	29.93	40.27
3	5350.00	55.0 PK	74.0	-19.0	1.19 H	249	14.66	40.34
4	5350.00	41.9 AV	54.0	-12.1	1.19 H	249	1.56	40.34
5	10620.00	53.6 PK	74.0	-20.4	1.14 H	211	6.74	46.86
6	10620.00	38.9 AV	54.0	-15.1	1.14 H	211	-7.96	46.86
ANTENNA POLARITY & TEST DISTANCE: VERTICAL AT 3 M								
NO.	FREQ. (MHz)	EMISSION LEVEL (dBuV/m)	LIMIT (dBuV/m)	MARGIN (dB)	ANTENNA HEIGHT (m)	TABLE ANGLE (Degree)	RAW VALUE (dBuV)	CORRECTION FACTOR (dB/m)
1	*5310.00	102.1 PK			1.22 V	92	61.83	40.27
2	*5310.00	78.6 AV			1.22 V	92	38.33	40.27
3	5350.00	65.9 PK	74.0	-8.1	1.22 V	92	25.56	40.34
4	5350.00	46.8 AV	54.0	-7.2	1.22 V	92	6.46	40.34
5	10620.00	54.2 PK	74.0	-19.8	1.20 V	100	7.34	46.86
6	10620.00	39.1 AV	54.0	-14.9	1.20 V	100	-7.76	46.86

REMARKS:

1. Emission level (dBuV/m) = Raw Value (dBuV) + Correction Factor (dB/m).
2. Correction Factor (dB/m) = Antenna Factor (dB/m) + Cable Factor (dB).
3. The other emission levels were very low against the limit.
4. Margin value = Emission level – Limit value.
5. " * ": Fundamental frequency.



ABOVE 1GHz WORST-CASE DATA: Band 3

802.11a

CHANNEL	TX Channel 100	DETECTOR FUNCTION	Peak (PK)
FREQUENCY RANGE	1GHz ~ 40GHz		Average (AV)

ANTENNA POLARITY & TEST DISTANCE: HORIZONTAL AT 3 M								
NO.	FREQ. (MHz)	EMISSION LEVEL (dBuV/m)	LIMIT (dBuV/m)	MARGIN (dB)	ANTENNA HEIGHT (m)	TABLE ANGLE (Degree)	RAW VALUE (dBuV)	CORRECTION FACTOR (dB/m)
1	5460.00	53.0 PK	74.0	-21.0	1.29 H	260	12.47	40.53
2	5460.00	41.5 AV	54.0	-12.5	1.29 H	260	0.97	40.53
3	#5470.00	54.8 PK	68.3	-13.5	1.29 H	260	14.25	40.55
4	*5500.00	90.6 PK			1.29 H	260	50.00	40.60
5	*5500.00	74.9 AV			1.29 H	260	34.30	40.60
6	11000.00	52.9 PK	74.0	-21.1	1.00 H	360	5.64	47.26
7	11000.00	38.9 AV	54.0	-15.1	1.00 H	360	-8.36	47.26

ANTENNA POLARITY & TEST DISTANCE: VERTICAL AT 3 M								
NO.	FREQ. (MHz)	EMISSION LEVEL (dBuV/m)	LIMIT (dBuV/m)	MARGIN (dB)	ANTENNA HEIGHT (m)	TABLE ANGLE (Degree)	RAW VALUE (dBuV)	CORRECTION FACTOR (dB/m)
1	5460.00	54.7 PK	74.0	-19.3	1.28 V	71	14.17	40.53
2	5460.00	41.4 AV	54.0	-12.6	1.28 V	71	0.87	40.53
3	#5470.00	56.2 PK	68.3	-12.1	1.28 V	71	15.65	40.55
4	*5500.00	102.1 PK			1.28 V	71	61.50	40.60
5	*5500.00	85.1 AV			1.28 V	71	44.50	40.60
6	11000.00	52.4 PK	74.0	-21.6	1.00 V	0	5.14	47.26
7	11000.00	37.9 AV	54.0	-16.1	1.00 V	0	-9.36	47.26

REMARKS:

1. Emission level (dBuV/m) = Raw Value (dBuV) + Correction Factor (dB/m).
2. Correction Factor (dB/m) = Antenna Factor (dB/m) + Cable Factor (dB).
3. The other emission levels were very low against the limit.
4. Margin value = Emission level – Limit value.
5. " * ": Fundamental frequency.
6. " # ": The radiated frequency is out of the restricted band.



CHANNEL	TX Channel 116	DETECTOR FUNCTION	Peak (PK)
FREQUENCY RANGE	1GHz ~ 40GHz		Average (AV)

ANTENNA POLARITY & TEST DISTANCE: HORIZONTAL AT 3 M

NO.	FREQ. (MHz)	EMISSION LEVEL (dBuV/m)	LIMIT (dBuV/m)	MARGIN (dB)	ANTENNA HEIGHT (m)	TABLE ANGLE (Degree)	RAW VALUE (dBuV)	CORRECTION FACTOR (dB/m)
1	*5580.00	91.9 PK			1.28 H	258	51.09	40.81
2	*5580.00	75.5 AV			1.28 H	258	34.69	40.81
3	11160.00	52.8 PK	74.0	-21.2	1.21 H	255	5.41	47.39
4	11160.00	38.2 AV	54.0	-15.8	1.21 H	255	-9.19	47.39

ANTENNA POLARITY & TEST DISTANCE: VERTICAL AT 3 M

NO.	FREQ. (MHz)	EMISSION LEVEL (dBuV/m)	LIMIT (dBuV/m)	MARGIN (dB)	ANTENNA HEIGHT (m)	TABLE ANGLE (Degree)	RAW VALUE (dBuV)	CORRECTION FACTOR (dB/m)
1	*5580.00	103.7 PK			1.26 V	74	62.89	40.81
2	*5580.00	87.0 AV			1.26 V	74	46.19	40.81
3	11160.00	53.4 PK	74.0	-20.6	1.22 V	121	6.01	47.39
4	11160.00	39.2 AV	54.0	-14.8	1.22 V	121	-8.19	47.39

REMARKS:

1. Emission level (dBuV/m) = Raw Value (dBuV) + Correction Factor (dB/m).
2. Correction Factor (dB/m) = Antenna Factor (dB/m) + Cable Factor (dB).
3. The other emission levels were very low against the limit.
4. Margin value = Emission level – Limit value.
5. " * ": Fundamental frequency.



CHANNEL	TX Channel 140	DETECTOR FUNCTION	Peak (PK)
FREQUENCY RANGE	1GHz ~ 40GHz		Average (AV)

ANTENNA POLARITY & TEST DISTANCE: HORIZONTAL AT 3 M								
NO.	FREQ. (MHz)	EMISSION LEVEL (dBuV/m)	LIMIT (dBuV/m)	MARGIN (dB)	ANTENNA HEIGHT (m)	TABLE ANGLE (Degree)	RAW VALUE (dBuV)	CORRECTION FACTOR (dB/m)
1	*5700.00	91.8 PK			1.24 H	270	50.67	41.13
2	*5700.00	75.0 AV			1.24 H	270	33.87	41.13
3	#5725.00	54.8 PK	68.3	-13.5	1.24 H	270	13.61	41.19
4	11400.00	54.4 PK	74.0	-19.6	1.31 H	278	6.80	47.60
5	11400.00	40.1 AV	54.0	-13.9	1.31 H	278	-7.50	47.60
ANTENNA POLARITY & TEST DISTANCE: VERTICAL AT 3 M								
NO.	FREQ. (MHz)	EMISSION LEVEL (dBuV/m)	LIMIT (dBuV/m)	MARGIN (dB)	ANTENNA HEIGHT (m)	TABLE ANGLE (Degree)	RAW VALUE (dBuV)	CORRECTION FACTOR (dB/m)
1	*5700.00	106.2 PK			1.21 V	72	65.07	41.13
2	*5700.00	89.0 AV			1.21 V	72	47.87	41.13
3	#5725.00	62.3 PK	68.3	-6.0	1.21 V	72	21.11	41.19
4	11400.00	53.2 PK	74.0	-20.8	1.16 V	67	5.60	47.60
5	11400.00	38.8 AV	54.0	-15.2	1.16 V	67	-8.80	47.60

REMARKS:

1. Emission level (dBuV/m) = Raw Value (dBuV) + Correction Factor (dB/m).
2. Correction Factor (dB/m) = Antenna Factor (dB/m) + Cable Factor (dB).
3. The other emission levels were very low against the limit.
4. Margin value = Emission level – Limit value.
5. " * ": Fundamental frequency.
6. " # ": The radiated frequency is out of the restricted band.



802.11n (20MHz)

CHANNEL	TX Channel 100	DETECTOR FUNCTION	Peak (PK)
FREQUENCY RANGE	1GHz ~ 40GHz		Average (AV)

ANTENNA POLARITY & TEST DISTANCE: HORIZONTAL AT 3 M								
NO.	FREQ. (MHz)	EMISSION LEVEL (dBuV/m)	LIMIT (dBuV/m)	MARGIN (dB)	ANTENNA HEIGHT (m)	TABLE ANGLE (Degree)	RAW VALUE (dBuV)	CORRECTION FACTOR (dB/m)
1	5460.00	53.1 PK	74.0	-20.9	1.15 H	261	12.57	40.53
2	5460.00	41.0 AV	54.0	-13.0	1.15 H	261	0.47	40.53
3	#5470.00	53.8 PK	68.3	-14.5	1.15 H	261	13.25	40.55
4	*5500.00	90.1 PK			1.15 H	261	49.50	40.60
5	*5500.00	73.4 AV			1.15 H	261	32.80	40.60
6	11000.00	53.1 PK	74.0	-20.9	1.26 H	294	5.84	47.26
7	11000.00	38.1 AV	54.0	-15.9	1.26 H	294	-9.16	47.26

ANTENNA POLARITY & TEST DISTANCE: VERTICAL AT 3 M								
NO.	FREQ. (MHz)	EMISSION LEVEL (dBuV/m)	LIMIT (dBuV/m)	MARGIN (dB)	ANTENNA HEIGHT (m)	TABLE ANGLE (Degree)	RAW VALUE (dBuV)	CORRECTION FACTOR (dB/m)
1	5460.00	54.5 PK	74.0	-19.5	1.19 V	91	13.97	40.53
2	5460.00	41.8 AV	54.0	-12.2	1.19 V	91	1.27	40.53
3	#5470.00	57.9 PK	68.3	-10.4	1.19 V	91	17.35	40.55
4	*5500.00	101.4 PK			1.19 V	91	60.80	40.60
5	*5500.00	84.2 AV			1.19 V	91	43.60	40.60
6	11000.00	53.2 PK	74.0	-20.8	1.24 V	102	5.94	47.26
7	11000.00	38.6 AV	54.0	-15.4	1.24 V	102	-8.66	47.26

REMARKS:

1. Emission level (dBuV/m) = Raw Value (dBuV) + Correction Factor (dB/m).
2. Correction Factor (dB/m) = Antenna Factor (dB/m) + Cable Factor (dB).
3. The other emission levels were very low against the limit.
4. Margin value = Emission level – Limit value.
5. " * ": Fundamental frequency.
6. " # ": The radiated frequency is out of the restricted band.



CHANNEL	TX Channel 116	DETECTOR FUNCTION	Peak (PK)
FREQUENCY RANGE	1GHz ~ 40GHz		Average (AV)

ANTENNA POLARITY & TEST DISTANCE: HORIZONTAL AT 3 M								
NO.	FREQ. (MHz)	EMISSION LEVEL (dBuV/m)	LIMIT (dBuV/m)	MARGIN (dB)	ANTENNA HEIGHT (m)	TABLE ANGLE (Degree)	RAW VALUE (dBuV)	CORRECTION FACTOR (dB/m)
1	*5580.00	91.8 PK			1.29 H	258	50.99	40.81
2	*5580.00	74.7 AV			1.29 H	258	33.89	40.81
3	11160.00	52.8 PK	74.0	-21.2	1.00 H	360	5.41	47.39
4	11160.00	37.6 AV	54.0	-16.4	1.00 H	360	-9.79	47.39
ANTENNA POLARITY & TEST DISTANCE: VERTICAL AT 3 M								
NO.	FREQ. (MHz)	EMISSION LEVEL (dBuV/m)	LIMIT (dBuV/m)	MARGIN (dB)	ANTENNA HEIGHT (m)	TABLE ANGLE (Degree)	RAW VALUE (dBuV)	CORRECTION FACTOR (dB/m)
1	*5580.00	104.2 PK			1.15 V	72	63.39	40.81
2	*5580.00	86.4 AV			1.15 V	72	45.59	40.81
3	11160.00	53.6 PK	74.0	-20.4	1.21 V	62	6.21	47.39
4	11160.00	38.8 AV	54.0	-15.2	1.21 V	62	-8.59	47.39

REMARKS:

1. Emission level (dBuV/m) = Raw Value (dBuV) + Correction Factor (dB/m).
2. Correction Factor (dB/m) = Antenna Factor (dB/m) + Cable Factor (dB).
3. The other emission levels were very low against the limit.
4. Margin value = Emission level – Limit value.
5. " * ": Fundamental frequency.



CHANNEL	TX Channel 140	DETECTOR FUNCTION	Peak (PK)
FREQUENCY RANGE	1GHz ~ 40GHz		Average (AV)

ANTENNA POLARITY & TEST DISTANCE: HORIZONTAL AT 3 M								
NO.	FREQ. (MHz)	EMISSION LEVEL (dBuV/m)	LIMIT (dBuV/m)	MARGIN (dB)	ANTENNA HEIGHT (m)	TABLE ANGLE (Degree)	RAW VALUE (dBuV)	CORRECTION FACTOR (dB/m)
1	*5700.00	91.9 PK			1.23 H	257	50.77	41.13
2	*5700.00	76.1 AV			1.23 H	257	34.97	41.13
3	#5725.00	54.3 PK	68.3	-14.0	1.23 H	257	13.11	41.19
4	11400.00	52.8 PK	74.0	-21.2	1.14 H	289	5.20	47.60
5	11400.00	37.6 AV	54.0	-16.4	1.14 H	289	-10.00	47.60
ANTENNA POLARITY & TEST DISTANCE: VERTICAL AT 3 M								
NO.	FREQ. (MHz)	EMISSION LEVEL (dBuV/m)	LIMIT (dBuV/m)	MARGIN (dB)	ANTENNA HEIGHT (m)	TABLE ANGLE (Degree)	RAW VALUE (dBuV)	CORRECTION FACTOR (dB/m)
1	*5700.00	105.4 PK			1.25 V	72	64.27	41.13
2	*5700.00	87.5 AV			1.25 V	72	46.37	41.13
3	#5725.00	64.8 PK	68.3	-3.5	1.25 V	72	23.61	41.19
4	11400.00	53.1 PK	74.0	-20.9	1.21 V	70	5.50	47.60
5	11400.00	38.4 AV	54.0	-15.6	1.21 V	70	-9.20	47.60

REMARKS:

1. Emission level (dBuV/m) = Raw Value (dBuV) + Correction Factor (dB/m).
2. Correction Factor (dB/m) = Antenna Factor (dB/m) + Cable Factor (dB).
3. The other emission levels were very low against the limit.
4. Margin value = Emission level – Limit value.
5. " * ": Fundamental frequency.
6. " # ": The radiated frequency is out of the restricted band.



802.11n (40MHz)

CHANNEL	TX Channel 102	DETECTOR FUNCTION	Peak (PK)
FREQUENCY RANGE	1GHz ~ 40GHz		Average (AV)

ANTENNA POLARITY & TEST DISTANCE: HORIZONTAL AT 3 M								
NO.	FREQ. (MHz)	EMISSION LEVEL (dBuV/m)	LIMIT (dBuV/m)	MARGIN (dB)	ANTENNA HEIGHT (m)	TABLE ANGLE (Degree)	RAW VALUE (dBuV)	CORRECTION FACTOR (dB/m)
1	5460.00	54.3 PK	74.0	-19.7	1.28 H	261	13.77	40.53
2	5460.00	41.6 AV	54.0	-12.4	1.28 H	261	1.07	40.53
3	#5470.00	54.6 PK	68.3	-13.7	1.28 H	261	14.05	40.55
4	*5510.00	87.5 PK			1.28 H	261	46.87	40.63
5	*5510.00	68.1 AV			1.28 H	261	27.47	40.63
6	11020.00	54.2 PK	74.0	-19.8	1.22 H	255	6.92	47.28
7	11020.00	40.1 AV	54.0	-13.9	1.22 H	255	-7.18	47.28

ANTENNA POLARITY & TEST DISTANCE: VERTICAL AT 3 M								
NO.	FREQ. (MHz)	EMISSION LEVEL (dBuV/m)	LIMIT (dBuV/m)	MARGIN (dB)	ANTENNA HEIGHT (m)	TABLE ANGLE (Degree)	RAW VALUE (dBuV)	CORRECTION FACTOR (dB/m)
1	5460.00	56.3 PK	74.0	-17.7	1.27 V	71	15.77	40.53
2	5460.00	42.5 AV	54.0	-11.5	1.27 V	71	1.97	40.53
3	#5470.00	63.1 PK	68.3	-5.2	1.27 V	71	22.55	40.55
4	*5510.00	100.9 PK			1.27 V	71	60.27	40.63
5	*5510.00	77.7 AV			1.27 V	71	37.07	40.63
6	11020.00	53.4 PK	74.0	-20.6	1.15 V	60	6.12	47.28
7	11020.00	39.7 AV	54.0	-14.3	1.15 V	60	-7.58	47.28

REMARKS:

1. Emission level (dBuV/m) = Raw Value (dBuV) + Correction Factor (dB/m).
2. Correction Factor (dB/m) = Antenna Factor (dB/m) + Cable Factor (dB).
3. The other emission levels were very low against the limit.
4. Margin value = Emission level – Limit value.
5. " * ": Fundamental frequency.
6. " # ": The radiated frequency is out of the restricted band.



CHANNEL	TX Channel 110	DETECTOR FUNCTION	Peak (PK)
FREQUENCY RANGE	1GHz ~ 40GHz		Average (AV)

ANTENNA POLARITY & TEST DISTANCE: HORIZONTAL AT 3 M								
NO.	FREQ. (MHz)	EMISSION LEVEL (dBuV/m)	LIMIT (dBuV/m)	MARGIN (dB)	ANTENNA HEIGHT (m)	TABLE ANGLE (Degree)	RAW VALUE (dBuV)	CORRECTION FACTOR (dB/m)
1	*5550.00	86.7 PK			1.13 H	260	45.97	40.73
2	*5550.00	67.2 AV			1.13 H	260	26.47	40.73
3	11100.00	53.1 PK	74.0	-20.9	1.11 H	244	5.76	47.34
4	11100.00	38.2 AV	54.0	-15.8	1.11 H	244	-9.14	47.34
ANTENNA POLARITY & TEST DISTANCE: VERTICAL AT 3 M								
NO.	FREQ. (MHz)	EMISSION LEVEL (dBuV/m)	LIMIT (dBuV/m)	MARGIN (dB)	ANTENNA HEIGHT (m)	TABLE ANGLE (Degree)	RAW VALUE (dBuV)	CORRECTION FACTOR (dB/m)
1	*5550.00	101.0 PK			1.27 V	70	60.27	40.73
2	*5550.00	78.0 AV			1.27 V	70	37.27	40.73
3	11100.00	53.8 PK	74.0	-20.2	1.22 V	79	6.46	47.34
4	11100.00	39.5 AV	54.0	-14.5	1.22 V	79	-7.84	47.34

REMARKS:

1. Emission level (dBuV/m) = Raw Value (dBuV) + Correction Factor (dB/m).
2. Correction Factor (dB/m) = Antenna Factor (dB/m) + Cable Factor (dB).
3. The other emission levels were very low against the limit.
4. Margin value = Emission level – Limit value.
5. " * ": Fundamental frequency.



CHANNEL	TX Channel 134	DETECTOR FUNCTION	Peak (PK)
FREQUENCY RANGE	1GHz ~ 40GHz		Average (AV)

ANTENNA POLARITY & TEST DISTANCE: HORIZONTAL AT 3 M								
NO.	FREQ. (MHz)	EMISSION LEVEL (dBuV/m)	LIMIT (dBuV/m)	MARGIN (dB)	ANTENNA HEIGHT (m)	TABLE ANGLE (Degree)	RAW VALUE (dBuV)	CORRECTION FACTOR (dB/m)
1	*5670.00	87.4 PK			1.12 H	251	46.35	41.05
2	*5670.00	67.7 AV			1.12 H	251	26.65	41.05
3	#5725.00	54.5 PK	68.3	-13.8	1.12 H	251	13.31	41.19
4	11340.00	54.6 PK	74.0	-19.4	1.08 H	244	7.05	47.55
5	11340.00	40.3 AV	54.0	-13.7	1.08 H	244	-7.25	47.55
ANTENNA POLARITY & TEST DISTANCE: VERTICAL AT 3 M								
NO.	FREQ. (MHz)	EMISSION LEVEL (dBuV/m)	LIMIT (dBuV/m)	MARGIN (dB)	ANTENNA HEIGHT (m)	TABLE ANGLE (Degree)	RAW VALUE (dBuV)	CORRECTION FACTOR (dB/m)
1	*5670.00	102.8 PK			1.24 V	73	61.75	41.05
2	*5670.00	79.1 AV			1.24 V	73	38.05	41.05
3	#5725.00	59.7 PK	68.3	-8.6	1.24 V	73	18.51	41.19
4	11340.00	53.2 PK	74.0	-20.8	1.21 V	89	5.65	47.55
5	11340.00	40.1 AV	54.0	-13.9	1.21 V	89	-7.45	47.55

REMARKS:

1. Emission level (dBuV/m) = Raw Value (dBuV) + Correction Factor (dB/m).
2. Correction Factor (dB/m) = Antenna Factor (dB/m) + Cable Factor (dB).
3. The other emission levels were very low against the limit.
4. Margin value = Emission level – Limit value.
5. " * ": Fundamental frequency.
6. " # ": The radiated frequency is out of the restricted band.



ABOVE 1GHz WORST-CASE DATA: Band 4

802.11a

CHANNEL	TX Channel 149	DETECTOR FUNCTION	Peak (PK)
FREQUENCY RANGE	1GHz ~ 40GHz		Average (AV)

ANTENNA POLARITY & TEST DISTANCE: HORIZONTAL AT 3 M

NO.	FREQ. (MHz)	EMISSION LEVEL (dBuV/m)	LIMIT (dBuV/m)	MARGIN (dB)	ANTENNA HEIGHT (m)	TABLE ANGLE (Degree)	RAW VALUE (dBuV)	CORRECTION FACTOR (dB/m)
1	#5715.00	50.4 PK	68.3	-17.9	1.29 H	162	9.23	41.17
2	#5725.00	53.0 PK	78.3	-25.3	1.29 H	162	11.80	41.19
3	*5745.00	88.0 PK			1.29 H	162	46.78	41.25
4	*5745.00	72.6 AV			1.29 H	162	31.31	41.25
5	11490.00	52.2 PK	74.0	-21.8	1.00 H	240	4.51	47.67
6	11490.00	40.3 AV	54.0	-13.7	1.00 H	240	-7.35	47.67

ANTENNA POLARITY & TEST DISTANCE: VERTICAL AT 3 M

NO.	FREQ. (MHz)	EMISSION LEVEL (dBuV/m)	LIMIT (dBuV/m)	MARGIN (dB)	ANTENNA HEIGHT (m)	TABLE ANGLE (Degree)	RAW VALUE (dBuV)	CORRECTION FACTOR (dB/m)
1	#5715.00	52.3 PK	68.3	-16.0	1.13 V	151	11.13	41.17
2	#5725.00	63.1 PK	78.3	-15.2	1.13 V	151	21.90	41.19
3	*5745.00	99.7 PK			1.13 V	151	58.41	41.25
4	*5745.00	83.2 AV			1.13 V	151	41.96	41.25
5	11490.00	52.8 PK	74.0	-21.3	1.00 V	250	5.08	47.67
6	11490.00	37.9 AV	54.0	-16.1	1.00 V	250	-9.79	47.67

REMARKS:

1. Emission level (dBuV/m) = Raw Value (dBuV) + Correction Factor (dB/m).
2. Correction Factor (dB/m) = Antenna Factor (dB/m) + Cable Factor (dB).
3. The other emission levels were very low against the limit.
4. Margin value = Emission level – Limit value.
5. " * ": Fundamental frequency.
6. " # ": The radiated frequency is out of the restricted band.



CHANNEL	TX Channel 157	DETECTOR FUNCTION	Peak (PK)
FREQUENCY RANGE	1GHz ~ 40GHz		Average (AV)

ANTENNA POLARITY & TEST DISTANCE: HORIZONTAL AT 3 M								
NO.	FREQ. (MHz)	EMISSION LEVEL (dBuV/m)	LIMIT (dBuV/m)	MARGIN (dB)	ANTENNA HEIGHT (m)	TABLE ANGLE (Degree)	RAW VALUE (dBuV)	CORRECTION FACTOR (dB/m)
1	*5785.00	87.7 PK			1.06 H	267	46.30	41.35
2	*5785.00	71.7 AV			1.06 H	267	30.31	41.35
3	11570.00	51.4 PK	74.0	-22.6	1.00 H	24	3.69	47.75
4	11570.00	39.8 AV	54.0	-14.2	1.00 H	24	-7.91	47.75
ANTENNA POLARITY & TEST DISTANCE: VERTICAL AT 3 M								
NO.	FREQ. (MHz)	EMISSION LEVEL (dBuV/m)	LIMIT (dBuV/m)	MARGIN (dB)	ANTENNA HEIGHT (m)	TABLE ANGLE (Degree)	RAW VALUE (dBuV)	CORRECTION FACTOR (dB/m)
1	*5785.00	96.7 PK			1.18 V	240	55.30	41.35
2	*5785.00	82.7 AV			1.18 V	240	41.30	41.35
3	11570.00	51.4 PK	74.0	-22.6	1.00 V	124	3.61	47.75
4	11570.00	40.1 AV	54.0	-14.0	1.00 V	124	-7.70	47.75

REMARKS:

1. Emission level (dBuV/m) = Raw Value (dBuV) + Correction Factor (dB/m).
2. Correction Factor (dB/m) = Antenna Factor (dB/m) + Cable Factor (dB).
3. The other emission levels were very low against the limit.
4. Margin value = Emission level – Limit value.
5. " * ": Fundamental frequency.



CHANNEL	TX Channel 161	DETECTOR FUNCTION	Peak (PK)
FREQUENCY RANGE	1GHz ~ 40GHz		Average (AV)

ANTENNA POLARITY & TEST DISTANCE: HORIZONTAL AT 3 M

NO.	FREQ. (MHz)	EMISSION LEVEL (dBuV/m)	LIMIT (dBuV/m)	MARGIN (dB)	ANTENNA HEIGHT (m)	TABLE ANGLE (Degree)	RAW VALUE (dBuV)	CORRECTION FACTOR (dB/m)
1	*5805.00	89.8 PK			1.28 H	164	48.34	41.41
2	*5805.00	75.5 AV			1.28 H	164	34.13	41.41
3	#5850.00	54.6 PK	78.3	-23.7	1.28 H	164	13.04	41.52
4	#5860.00	54.6 PK	68.3	-13.7	1.28 H	164	13.01	41.55
5	11610.00	52.9 PK	74.0	-21.1	1.12 H	200	5.08	47.79
6	11610.00	39.7 AV	54.0	-14.4	1.12 H	200	-8.14	47.79

ANTENNA POLARITY & TEST DISTANCE: VERTICAL AT 3 M

NO.	FREQ. (MHz)	EMISSION LEVEL (dBuV/m)	LIMIT (dBuV/m)	MARGIN (dB)	ANTENNA HEIGHT (m)	TABLE ANGLE (Degree)	RAW VALUE (dBuV)	CORRECTION FACTOR (dB/m)
1	*5805.00	98.6 PK			1.32 V	234	57.23	41.41
2	*5805.00	85.2 AV			1.32 V	234	43.83	41.41
3	#5850.00	54.5 PK	78.3	-23.8	1.32 V	234	12.96	41.52
4	#5860.00	54.6 PK	68.3	-13.7	1.32 V	234	13.04	41.55
5	11610.00	54.7 PK	74.0	-19.4	1.00 V	57	6.86	47.79
6	11610.00	40.3 AV	54.0	-13.8	1.00 V	57	-7.54	47.79

REMARKS:

1. Emission level (dBuV/m) = Raw Value (dBuV) + Correction Factor (dB/m).
2. Correction Factor (dB/m) = Antenna Factor (dB/m) + Cable Factor (dB).
3. The other emission levels were very low against the limit.
4. Margin value = Emission level – Limit value.
5. " * ": Fundamental frequency.
6. " # ": The radiated frequency is out of the restricted band.



802.11n (20MHz)

CHANNEL	TX Channel 149	DETECTOR FUNCTION	Peak (PK)
FREQUENCY RANGE	1GHz ~ 40GHz		Average (AV)

ANTENNA POLARITY & TEST DISTANCE: HORIZONTAL AT 3 M								
NO.	FREQ. (MHz)	EMISSION LEVEL (dBuV/m)	LIMIT (dBuV/m)	MARGIN (dB)	ANTENNA HEIGHT (m)	TABLE ANGLE (Degree)	RAW VALUE (dBuV)	CORRECTION FACTOR (dB/m)
1	#5715.00	54.0 PK	68.3	-14.3	1.06 H	164	12.80	41.17
2	#5725.00	56.4 PK	78.3	-21.9	1.06 H	164	15.21	41.19
3	*5745.00	90.1 PK			1.06 H	164	48.85	41.25
4	*5745.00	78.3 AV			1.06 H	164	37.00	41.25
5	11490.00	53.1 PK	74.0	-20.9	1.18 H	302	5.44	47.67
6	11490.00	40.1 AV	54.0	-13.9	1.18 H	302	-7.58	47.67
ANTENNA POLARITY & TEST DISTANCE: VERTICAL AT 3 M								
NO.	FREQ. (MHz)	EMISSION LEVEL (dBuV/m)	LIMIT (dBuV/m)	MARGIN (dB)	ANTENNA HEIGHT (m)	TABLE ANGLE (Degree)	RAW VALUE (dBuV)	CORRECTION FACTOR (dB/m)
1	#5715.00	58.9 PK	68.3	-9.4	1.12 V	170	17.73	41.17
2	#5725.00	67.1 PK	78.3	-11.2	1.12 V	170	25.88	41.19
3	*5745.00	99.7 PK			1.12 V	170	58.46	41.25
4	*5745.00	85.6 AV			1.12 V	170	44.39	41.25
5	11490.00	51.7 PK	74.0	-22.3	1.00 V	214	4.01	47.67
6	11490.00	39.7 AV	54.0	-14.4	1.00 V	214	-8.02	47.67

REMARKS:

1. Emission level (dBuV/m) = Raw Value (dBuV) + Correction Factor (dB/m).
2. Correction Factor (dB/m) = Antenna Factor (dB/m) + Cable Factor (dB).
3. The other emission levels were very low against the limit.
4. Margin value = Emission level – Limit value.
5. " * ": Fundamental frequency.
6. " # ": The radiated frequency is out of the restricted band.



CHANNEL	TX Channel 157	DETECTOR FUNCTION	Peak (PK)
FREQUENCY RANGE	1GHz ~ 40GHz		Average (AV)

ANTENNA POLARITY & TEST DISTANCE: HORIZONTAL AT 3 M								
NO.	FREQ. (MHz)	EMISSION LEVEL (dBuV/m)	LIMIT (dBuV/m)	MARGIN (dB)	ANTENNA HEIGHT (m)	TABLE ANGLE (Degree)	RAW VALUE (dBuV)	CORRECTION FACTOR (dB/m)
1	*5785.00	89.4 PK			1.31 H	154	48.09	41.35
2	*5785.00	71.8 AV			1.31 H	154	30.45	41.35
3	11570.00	52.7 PK	74.0	-21.3	1.01 H	265	4.93	47.75
4	11570.00	38.2 AV	54.0	-15.8	1.01 H	265	-9.51	47.75
ANTENNA POLARITY & TEST DISTANCE: VERTICAL AT 3 M								
NO.	FREQ. (MHz)	EMISSION LEVEL (dBuV/m)	LIMIT (dBuV/m)	MARGIN (dB)	ANTENNA HEIGHT (m)	TABLE ANGLE (Degree)	RAW VALUE (dBuV)	CORRECTION FACTOR (dB/m)
1	*5785.00	100.0 PK			1.02 V	181	58.62	41.35
2	*5785.00	81.6 AV			1.02 V	181	40.22	41.35
3	11570.00	54.4 PK	74.0	-19.6	1.00 V	14	6.61	47.75
4	11570.00	41.3 AV	54.0	-12.7	1.00 V	14	-6.48	47.75

REMARKS:

1. Emission level (dBuV/m) = Raw Value (dBuV) + Correction Factor (dB/m).
2. Correction Factor (dB/m) = Antenna Factor (dB/m) + Cable Factor (dB).
3. The other emission levels were very low against the limit.
4. Margin value = Emission level – Limit value.
5. " * ": Fundamental frequency.



CHANNEL	TX Channel 161	DETECTOR FUNCTION	Peak (PK)
FREQUENCY RANGE	1GHz ~ 40GHz		Average (AV)

ANTENNA POLARITY & TEST DISTANCE: HORIZONTAL AT 3 M

NO.	FREQ. (MHz)	EMISSION LEVEL (dBuV/m)	LIMIT (dBuV/m)	MARGIN (dB)	ANTENNA HEIGHT (m)	TABLE ANGLE (Degree)	RAW VALUE (dBuV)	CORRECTION FACTOR (dB/m)
1	*5805.00	88.9 PK			1.25 H	221	47.45	41.41
2	*5805.00	74.7 AV			1.25 H	221	33.24	41.41
3	#5850.00	54.5 PK	78.3	-23.8	1.25 H	221	12.99	41.52
4	#5860.00	55.1 PK	68.3	-13.2	1.25 H	221	13.54	41.55
5	11610.00	51.2 PK	74.0	-22.8	1.20 H	65	3.43	47.79
6	11610.00	39.0 AV	54.0	-15.0	1.20 H	65	-8.83	47.79

ANTENNA POLARITY & TEST DISTANCE: VERTICAL AT 3 M

NO.	FREQ. (MHz)	EMISSION LEVEL (dBuV/m)	LIMIT (dBuV/m)	MARGIN (dB)	ANTENNA HEIGHT (m)	TABLE ANGLE (Degree)	RAW VALUE (dBuV)	CORRECTION FACTOR (dB/m)
1	*5805.00	101.1 PK			1.00 V	151	59.67	41.41
2	*5805.00	84.6 AV			1.00 V	151	43.22	41.41
3	#5850.00	58.5 PK	78.3	-19.8	1.00 V	151	16.96	41.52
4	#5860.00	53.5 PK	68.3	-14.8	1.00 V	151	11.93	41.55
5	11610.00	56.2 PK	74.0	-17.8	1.05 V	176	8.45	47.79
6	11610.00	41.6 AV	54.0	-12.4	1.05 V	176	-6.21	47.79

REMARKS:

1. Emission level (dBuV/m) = Raw Value (dBuV) + Correction Factor (dB/m).
2. Correction Factor (dB/m) = Antenna Factor (dB/m) + Cable Factor (dB).
3. The other emission levels were very low against the limit.
4. Margin value = Emission level – Limit value.
5. " * ": Fundamental frequency.
6. " # ": The radiated frequency is out of the restricted band.



802.11n (40MHz)

CHANNEL	TX Channel 151	DETECTOR FUNCTION	Peak (PK)
FREQUENCY RANGE	1GHz ~ 40GHz		Average (AV)

ANTENNA POLARITY & TEST DISTANCE: HORIZONTAL AT 3 M								
NO.	FREQ. (MHz)	EMISSION LEVEL (dBuV/m)	LIMIT (dBuV/m)	MARGIN (dB)	ANTENNA HEIGHT (m)	TABLE ANGLE (Degree)	RAW VALUE (dBuV)	CORRECTION FACTOR (dB/m)
1	#5715.00	52.5 PK	68.3	-15.8	1.00 H	177	11.35	41.17
2	#5725.00	54.6 PK	78.3	-23.7	1.00 H	177	13.38	41.19
3	*5755.00	85.0 PK			1.00 H	177	43.70	41.27
4	*5755.00	66.5 AV			1.00 H	177	25.27	41.27
5	11510.00	52.0 PK	74.0	-22.1	1.00 H	238	4.26	47.69
6	11510.00	39.5 AV	54.0	-14.6	1.00 H	238	-8.24	47.69
ANTENNA POLARITY & TEST DISTANCE: VERTICAL AT 3 M								
NO.	FREQ. (MHz)	EMISSION LEVEL (dBuV/m)	LIMIT (dBuV/m)	MARGIN (dB)	ANTENNA HEIGHT (m)	TABLE ANGLE (Degree)	RAW VALUE (dBuV)	CORRECTION FACTOR (dB/m)
1	#5715.00	57.5 PK	68.3	-10.8	1.14 V	175	16.36	41.17
2	#5725.00	58.6 PK	78.3	-19.7	1.14 V	175	17.36	41.19
3	*5755.00	93.3 PK			1.14 V	175	52.01	41.27
4	*5755.00	79.5 AV			1.14 V	175	38.25	41.27
5	11510.00	54.3 PK	74.0	-19.8	1.02 V	162	6.56	47.69
6	11510.00	41.9 AV	54.0	-12.2	1.02 V	162	-5.84	47.69

REMARKS:

1. Emission level (dBuV/m) = Raw Value (dBuV) + Correction Factor (dB/m).
2. Correction Factor (dB/m) = Antenna Factor (dB/m) + Cable Factor (dB).
3. The other emission levels were very low against the limit.
4. Margin value = Emission level – Limit value.
5. " * ": Fundamental frequency.
6. " # ": The radiated frequency is out of the restricted band.



CHANNEL	TX Channel 159	DETECTOR FUNCTION	Peak (PK)
FREQUENCY RANGE	1GHz ~ 40GHz		Average (AV)

ANTENNA POLARITY & TEST DISTANCE: HORIZONTAL AT 3 M								
NO.	FREQ. (MHz)	EMISSION LEVEL (dBuV/m)	LIMIT (dBuV/m)	MARGIN (dB)	ANTENNA HEIGHT (m)	TABLE ANGLE (Degree)	RAW VALUE (dBuV)	CORRECTION FACTOR (dB/m)
1	*5795.00	85.7 PK			1.04 H	174	44.28	41.38
2	*5795.00	70.5 AV			1.04 H	174	29.07	41.38
3	#5850.00	44.4 PK	78.3	-33.9	1.04 H	174	2.91	41.52
4	#5860.00	43.3 PK	68.3	-25.0	1.04 H	174	1.78	41.55
5	11590.00	51.1 PK	74.0	-22.9	1.00 H	196	3.36	47.77
6	11590.00	37.5 AV	54.0	-16.5	1.00 H	196	-10.25	47.77
ANTENNA POLARITY & TEST DISTANCE: VERTICAL AT 3 M								
NO.	FREQ. (MHz)	EMISSION LEVEL (dBuV/m)	LIMIT (dBuV/m)	MARGIN (dB)	ANTENNA HEIGHT (m)	TABLE ANGLE (Degree)	RAW VALUE (dBuV)	CORRECTION FACTOR (dB/m)
1	*5795.00	98.8 PK			1.03 V	79	57.43	41.38
2	*5795.00	84.7 AV			1.03 V	79	43.27	41.38
3	#5850.00	56.2 PK	78.3	-22.1	1.03 V	79	14.64	41.52
4	#5860.00	53.3 PK	68.3	-15.0	1.03 V	79	11.73	41.55
5	11590.00	53.2 PK	74.0	-20.8	1.00 V	147	5.47	47.77
6	11590.00	40.8 AV	54.0	-13.3	1.00 V	147	-7.02	47.77

REMARKS:

1. Emission level (dBuV/m) = Raw Value (dBuV) + Correction Factor (dB/m).
2. Correction Factor (dB/m) = Antenna Factor (dB/m) + Cable Factor (dB).
3. The other emission levels were very low against the limit.
4. Margin value = Emission level – Limit value.
5. " * ": Fundamental frequency.
6. " # ": The radiated frequency is out of the restricted band.



4.2 CONDUCTED EMISSION MEASUREMENT

4.2.1 LIMITS OF CONDUCTED EMISSION MEASUREMENT

FREQUENCY OF EMISSION (MHz)	CONDUCTED LIMIT (dBµV)	
	Quasi-peak	Average
0.15 ~ 0.5	66 to 56	56 to 46
0.5 ~ 5	56	46
5 ~ 30	60	50

- NOTE:**
1. The lower limit shall apply at the transition frequencies.
 2. The limit decreases in line with the logarithm of the frequency in the range of 0.15 to 0.50MHz.
 3. All emanations from a class A/B digital device or system, including any network of conductors and apparatus connected thereto, shall not exceed the level of field strengths specified above.

4.2.2 TEST INSTRUMENTS

Equipment	Manufacturer	Model No.	Serial No.	Last Cal.	Next Cal.
EMI Test Receiver	Rohde&Schwarz	ESCI	101418	Mar. 28,14	Mar. 27,15
Artificial Mains Network	Rohde&Schwarz	ENV216	101173	May 14,14	May 13,15
Artificial Mains Network	Rohde&Schwarz	ESH3-Z5	100317	May 14,14	May 13,15
Test software	ADT	ADT_Cond_V7.3.7	N/A	N/A	N/A

- NOTE:**
1. The test was performed in shielded room 553.
 2. The calibration interval of the above test instruments is 12 months. And the calibrations are traceable to CEPREI/CHINA, GRGT/CHINA and NIM/CHINA.

4.2.3 TEST PROCEDURES

- a. The EUT was placed 0.4 meters from the conducting wall of the shielded room with EUT being connected to the power mains through a line impedance stabilization network (LISN). Other support units were connected to the power mains through another LISN. The two LISNs provide 50 ohm/ 50uH of coupling impedance for the measuring instrument.
- b. Both lines of the power mains connected to the EUT were checked for maximum conducted interference.
- c. The frequency range from 150kHz to 30MHz was searched. Emission levels under (Limit - 20dB) was not recorded.

NOTE: All modes of operation were investigated and the worst-case emissions are reported.



4.2.4 DEVIATION FROM TEST STANDARD

No deviation.

4.2.5 TEST SETUP

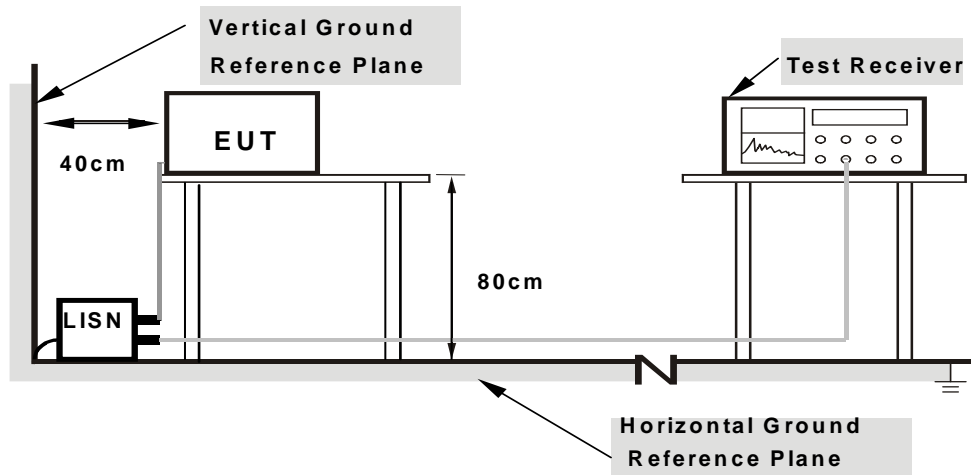

- Note:**
- 1.Support units were connected to second LISN.
 - 2.Both of LISNs (AMN) are 80 cm from EUT and at least 80 from other units and other metal planes

For the actual test configuration, please refer to the attached file (Test Setup Photo).

4.2.6 EUT OPERATING CONDITIONS

Same as 4.1.6.



4.2.7 TEST RESULTS

CONDUCTED WORST-CASE DATA : 802.11a

PHASE	Line	6dB BANDWIDTH	9kHz
CHANNEL	Channel 36		

No	Freq. [MHz]	Corr. Factor (dB)	Reading Value [dB (uV)]		Emission Level [dB (uV)]		Limit [dB (uV)]		Margin (dB)	
			Q.P.	AV.	Q.P.	AV.	Q.P.	AV.	Q.P.	AV.
1	0.16955	10.75	31.04	14.33	41.79	25.08	64.98	54.98	-23.19	-29.90
2	0.20084	10.63	30.67	14.99	41.30	25.62	63.58	53.58	-22.28	-27.96
3	0.53709	10.53	24.91	14.56	35.44	25.09	56.00	46.00	-20.56	-20.91
4	0.62311	10.48	31.48	22.22	41.96	32.70	56.00	46.00	-14.04	-13.30
5	18.42925	10.71	22.65	6.99	33.36	17.70	60.00	50.00	-26.64	-32.30
6	21.61981	10.97	23.92	13.48	34.89	24.45	60.00	50.00	-25.11	-25.55

- REMARKS:**
1. Q.P. and AV. are abbreviations of quasi-peak and average individually.
 2. "-": The Quasi-peak reading value also meets average limit and measurement with the average detector is unnecessary.
 3. The emission levels of other frequencies were very low against the limit.
 4. Margin value = Emission level - Limit value
 5. Correction factor = Insertion loss + Cable loss
 6. Emission Level = Correction Factor + Reading Value.

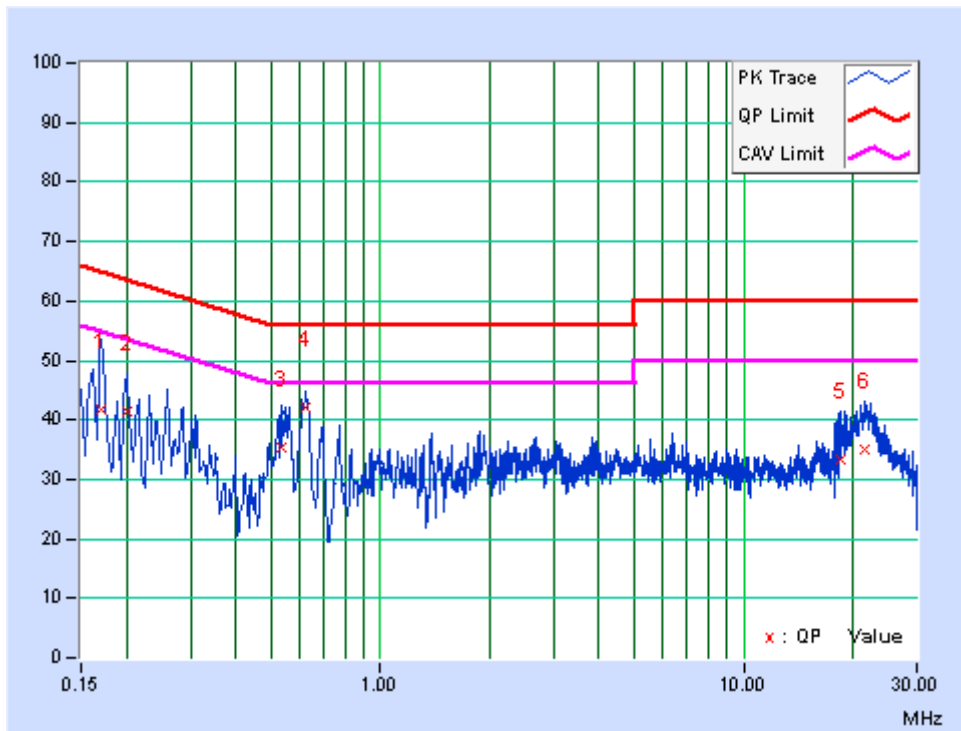



PHASE	Neutral	6dB BANDWIDTH	9kHz
CHANNEL	Channel 36		

No	Freq. [MHz]	Corr. Factor (dB)	Reading Value [dB (uV)]		Emission Level [dB (uV)]		Limit [dB (uV)]		Margin (dB)	
			Q.P.	AV.	Q.P.	AV.	Q.P.	AV.	Q.P.	AV.
1	0.15391	10.62	33.78	15.40	44.40	26.02	65.79	55.79	-21.38	-29.76
2	0.16569	10.60	31.24	11.87	41.84	22.47	65.17	55.17	-23.34	-32.71
3	0.20893	10.52	26.46	10.60	36.98	21.12	63.25	53.25	-26.27	-32.13
4	0.26339	10.52	22.71	8.41	33.23	18.93	61.32	51.32	-28.10	-32.40
5	0.6192	10.45	29.00	16.13	39.45	26.58	56.00	46.00	-16.55	-19.42
6	24.10657	11.05	31.16	15.13	42.21	26.18	60.00	50.00	-17.79	-23.82

- REMARKS:**
1. Q.P. and AV. are abbreviations of quasi-peak and average individually.
 2. "-": The Quasi-peak reading value also meets average limit and measurement with the average detector is unnecessary.
 3. The emission levels of other frequencies were very low against the limit.
 4. Margin value = Emission level - Limit value
 5. Correction factor = Insertion loss + Cable loss
 6. Emission Level = Correction Factor + Reading Value.

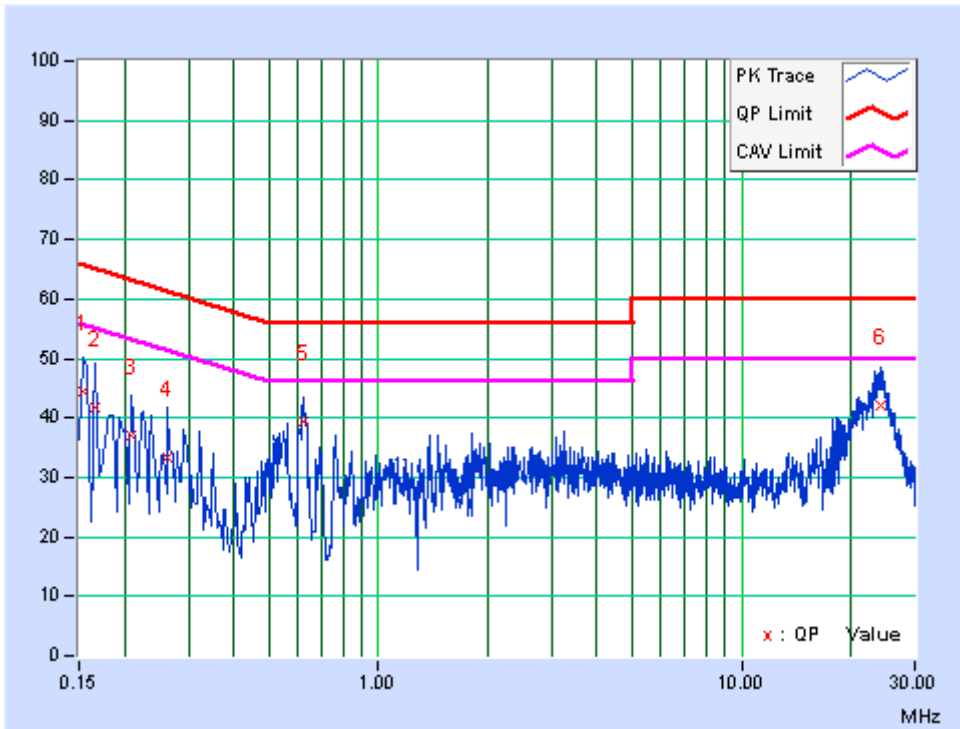



4.3 MAXIMUM CONDUCTED OUTPUT POWER MEASUREMENT

4.3.1 LIMITS OF MAXIMUM CONDUCTED OUTPUT POWER MEASUREMENT

Operation Band	EUT Category		LIMIT
U-NII-1		Outdoor Access Point	1 Watt (30 dBm) (Max. e.i.r.p \cong 125mW(21 dBm) at any elevation angle above 30 degrees as measured from the horizon)
		Fixed point-to-point Access Point	1 Watt (30 dBm)
		Indoor Access Point	1 Watt (30 dBm)
	√	Mobile and Portable client device	250mW (24 dBm)
U-NII-2A	---		250mW (24 dBm) or 11 dBm+10 log B*
U-NII-2C	---		250mW (24 dBm) or 11 dBm+10 log B*
U-NII-3	---		1 Watt (30 dBm)

NOTE: Where B is the 26dB emission bandwidth in MHz.

4.3.1 TEST SETUP

FOR POWER OUTPUT MEASUREMENT

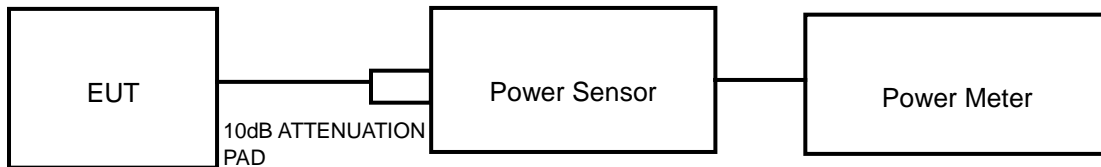

FOR 26dB BANDWIDTH

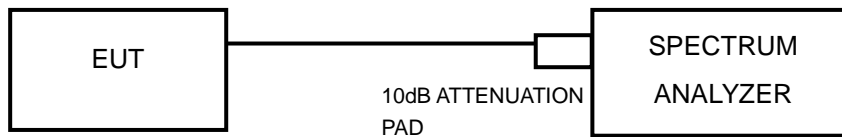



4.3.2 TEST INSTRUMENTS

Refer to section 4.1.3 to get information of above instrument.

4.3.3 TEST PROCEDURE

FOR POWER MEASUREMENT

Method PM is used to perform output power measurement, trigger and gating function of wide band power meter is enabled to measure max output power of TX on burst. Duty factor is not added to measured value.

FOR 26dB BANDWIDTH

- 1) Set RBW = approximately 1% of the emission bandwidth.
- 2) Set the VBW > RBW.
- 3) Detector = Peak.
- 4) Trace mode = max hold.
- 5) Measure the maximum width of the emission that is 26 dB down from the peak of the emission. Compare this with the RBW setting of the analyzer. Readjust RBW and repeat measurement as needed until the RBW/EBW ratio is approximately 1%.

FOR 6dB BANDWIDTH

1. Set RBW = 100 kHz.
2. Set the video bandwidth (VBW) ≥ 3 RBW.
3. Detector = Peak.
4. Trace mode = max hold.
5. Sweep = auto couple.
6. Allow the trace to stabilize.
7. Measure the maximum width of the emission that is constrained by the frequencies associated with the two outermost amplitude points (upper and lower frequencies) that are attenuated by 6 dB relative to the maximum level measured in the fundamental emission.

4.3.4 DEVIATION FROM TEST STANDARD

No deviation.



4.3.5 EUT OPERATING CONDITIONS

The software provided by client to enable the EUT under transmission condition continuously at specific channel frequencies individually.



4.3.6 TEST RESULTS

OUTPUT POWER:

802.11a

CHANNEL	CHANNEL FREQUENCY (MHz)	AVERAGE POWER (mW)	AVERAGE POWER (dBm)	POWER LIMIT (dBm)	PASS/FAIL
36	5180	7.499	8.75	24	PASS
40	5200	7.379	8.68	24	PASS
48	5240	7.674	8.85	24	PASS
52	5260	7.834	8.94	24	PASS
60	5300	7.482	8.74	24	PASS
64	5320	7.691	8.86	24	PASS
100	5500	7.656	8.84	24	PASS
116	5580	7.621	8.82	24	PASS
140	5700	8.035	9.05	24	PASS
149	5745	7.551	8.78	30	PASS
157	5785	7.568	8.79	30	PASS
161	5805	6.622	8.21	30	PASS

802.11n (20MHz)

CHANNEL	CHANNEL FREQUENCY (MHz)	AVERAGE POWER (mW)	AVERAGE POWER (dBm)	POWER LIMIT (dBm)	PASS/FAIL
36	5180	7.674	8.85	24	PASS
40	5200	7.780	8.91	24	PASS
48	5240	7.709	8.87	24	PASS
52	5260	7.379	8.68	24	PASS
60	5300	7.568	8.79	24	PASS
64	5320	7.745	8.89	24	PASS
100	5500	7.603	8.81	24	PASS
116	5580	8.035	9.05	24	PASS
140	5700	7.499	8.75	24	PASS
149	5745	7.638	8.83	30	PASS
157	5785	7.047	8.48	30	PASS
161	5805	6.792	8.32	30	PASS



802.11n (40MHz)

CHANNEL	CHANNEL FREQUENCY (MHz)	AVERAGE POWER (mW)	AVERAGE POWER (dBm)	POWER LIMIT (dBm)	PASS/FAIL
38	5190	7.551	8.78	24	PASS
46	5230	7.278	8.62	24	PASS
54	5270	7.852	8.95	24	PASS
62	5310	7.464	8.73	24	PASS
102	5510	7.603	8.81	24	PASS
110	5550	7.482	8.74	24	PASS
134	5670	7.889	8.97	24	PASS
151	5755	6.839	8.35	30	PASS
159	5795	6.622	8.21	30	PASS



26dB BANDWIDTH & 6dB BANDWIDTH:

802.11a

CHANNEL	CHANNEL FREQUENCY (MHz)	26dBc BANDWIDTH (MHz)	PASS / FAIL
36	5180	20.86	PASS
40	5200	20.28	PASS
48	5240	20.42	PASS
52	5260	20.89	PASS
60	5300	20.19	PASS
64	5320	21.56	PASS
100	5500	20.78	PASS
116	5580	20.34	PASS
132	5660	20.45	PASS
140	5700	20.17	PASS
CHANNEL	CHANNEL FREQUENCY (MHz)	6dBc BANDWIDTH (MHz)	PASS / FAIL
149	5745	16.37	PASS
157	5785	16.39	PASS
161	5805	16.45	PASS

802.11n (20MHz)

CHANNEL	CHANNEL FREQUENCY (MHz)	26dBc BANDWIDTH (MHz)	PASS / FAIL
36	5180	20.95	PASS
40	5200	20.59	PASS
48	5240	21.15	PASS
52	5260	21.01	PASS
60	5300	20.78	PASS
64	5320	20.63	PASS
100	5500	20.94	PASS
116	5580	21.52	PASS
132	5660	21.32	PASS
140	5700	21.08	PASS
CHANNEL	CHANNEL FREQUENCY (MHz)	6dBc BANDWIDTH (MHz)	PASS / FAIL
149	5745	17.63	PASS
157	5785	17.64	PASS
161	5805	17.55	PASS



802.11n (40MHz)

CHANNEL	CHANNEL FREQUENCY (MHz)	26dBc BANDWIDTH (MHz)	PASS / FAIL
38	5190	43.32	PASS
46	5230	42.77	PASS
54	5270	43.59	PASS
62	5310	44.09	PASS
102	5510	43.53	PASS
110	5550	43.58	PASS
134	5670	43.94	PASS
CHANNEL	CHANNEL FREQUENCY (MHz)	6dBc BANDWIDTH (MHz)	PASS / FAIL
151	5755	35.24	PASS
159	5795	35.20	PASS



4.4 PEAK POWER SPECTRAL DENSITY MEASUREMENT

4.4.1 LIMITS OF PEAK POWER SPECTRAL DENSITY MEASUREMENT

Operation Band	EUT Category		LIMIT
U-NII-1		Outdoor Access Point	17dBm/ MHz
		Fixed point-to-point Access Point	
		Indoor Access Point	
	√	Mobile and Portable client device	11dBm/ MHz
U-NII-2A	---		11dBm/ MHz
U-NII-2C	---		11dBm/ MHz
U-NII-3	---		30dBm/ 500kHz

4.4.2 TEST SETUP

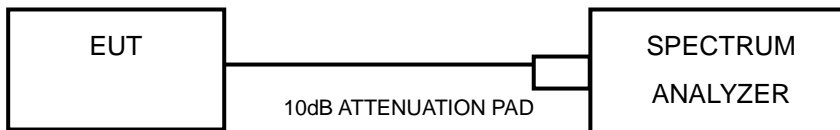

4.4.3 TEST INSTRUMENTS

Refer to section 4.1.3 to get information of above instrument.

4.4.4 TEST PROCEDURES

Using method SA-1

- 1) Set span to encompass the entire emission bandwidth (EBW) of the signal.
- 2) Set RBW = 30 KHz, Set VBW ≥ 1 MHz, Detector = RMS
- 3) Set Channel power measure = 1MHz
- 4) Sweep time = auto, trigger set to “free run”.
- 5) Trace average at least 100 traces in power averaging mode.
- 6) Record the max value



BUREAU Test Report No.: RF140812N017-5
VERITAS

4.4.5 DEVIATION FROM TEST STANDARD

No deviation.

4.4.6 EUT OPERATING CONDITIONS

Same as 4.1.6.



4.4.7 TEST RESULTS

For U-NII-1, U-NII-2A & U-NII-2C:

802.11a

CHANNEL	FREQUENCY (MHz)	PSD w/o Duty Factor (dBm/MHz)	Duty Factor	PSD with Duty Factor (dBm/MHz)	MAXIMUM LIMIT (dBm/MHz)	PASS/FAIL
36	5180	3.81	0.54	4.35	11	PASS
40	5200	3.86	0.54	4.40	11	PASS
48	5240	4.01	0.54	4.55	11	PASS
52	5260	2.79	0.54	3.33	11	PASS
60	5300	3.36	0.54	3.90	11	PASS
64	5320	3.83	0.54	4.37	11	PASS
100	5500	1.61	0.54	2.15	11	PASS
116	5580	2.22	0.54	2.76	11	PASS
132	5660	2.21	0.54	2.75	11	PASS
140	5700	2.35	0.54	2.89	11	PASS

802.11n (20MHz)

CHANNEL	FREQUENCY (MHz)	PSD w/o Duty Factor (dBm/MHz)	Duty Factor	PSD with Duty Factor (dBm/MHz)	MAXIMUM LIMIT (dBm/MHz)	PASS/FAIL
36	5180	2.37	0.57	2.94	11	PASS
40	5200	2.68	0.57	2.25	11	PASS
48	5240	2.20	0.57	2.77	11	PASS
52	5260	2.84	0.57	2.41	11	PASS
60	5300	3.21	0.57	3.78	11	PASS
64	5320	3.08	0.57	3.65	11	PASS
100	5500	1.60	0.57	2.17	11	PASS
116	5580	1.60	0.57	2.17	11	PASS
132	5660	2.05	0.57	2.62	11	PASS
140	5700	2.26	0.57	2.83	11	PASS



802.11n (40MHz)

CHANNEL	FREQUENCY (MHz)	PSD w/o Duty Factor (dBm/MHz)	Duty Factor	PSD with Duty Factor (dBm/MHz)	MAXIMUM LIMIT (dBm/MHz)	PASS/FAIL
38	5190	-0.66	1.07	0.41	11	PASS
46	5230	-0.96	1.07	0.11	11	PASS
54	5270	-9.60	1.07	-8.53	11	PASS
62	5310	0.02	1.07	1.09	11	PASS
102	5510	-0.89	1.07	0.18	11	PASS
110	5550	-1.14	1.07	-0.07	11	PASS
134	5670	-0.65	1.07	0.42	11	PASS



For U-NII-3:

802.11a

CHANNEL	FREQUENCY (MHz)	PSD w/o Duty Factor (dBm/100kHz)	PSD w/o Duty Factor (dBm/500kHz)	Duty Factor	PSD with Duty Factor (dBm/500kHz)	LIMIT (dBm/500kHz)	PASS /FAIL
149	5745	-2.00	4.99	0.54	5.53	30	PASS
157	5785	-1.85	5.14	0.54	5.68	30	PASS
161	5805	-1.63	5.36	0.54	5.9	30	PASS

802.11n (20M)

CHANNEL	FREQUENCY (MHz)	PSD w/o Duty Factor (dBm/100kHz)	PSD w/o Duty Factor (dBm/500kHz)	Duty Factor	PSD with Duty Factor (dBm/500kHz)	LIMIT (dBm/500kHz)	PASS /FAIL
149	5745	-2.20	4.79	0.57	5.36	30	PASS
157	5785	-1.78	5.21	0.57	5.78	30	PASS
161	5805	-1.63	5.36	0.57	5.93	30	PASS

802.11n (40MHz)

CHANNEL	FREQUENCY (MHz)	PSD w/o Duty Factor (dBm/100kHz)	PSD w/o Duty Factor (dBm/500kHz)	Duty Factor	PSD with Duty Factor (dBm/500kHz)	LIMIT (dBm/500kHz)	PASS /FAIL
151	5755	-7.00	-0.01	1.07	1.06	30	PASS
159	5795	-4.81	2.18	1.07	3.25	30	PASS



4.5 FREQUENCY STABILITY

4.5.1 LIMITS OF FREQUENCY STABILITY MEASUREMENT

The frequency of the carrier signal shall be maintained within band of operation

4.5.2 TEST SETUP

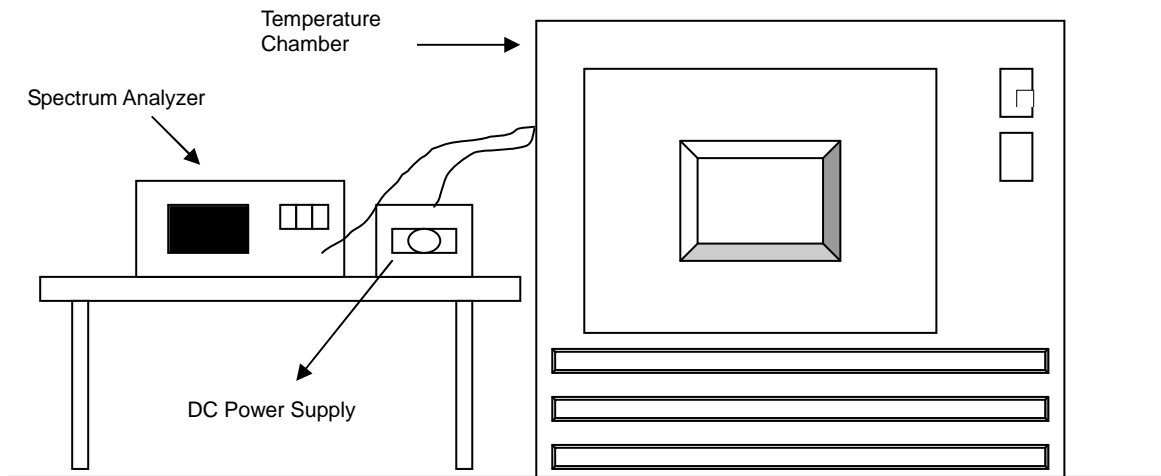

4.5.3 TEST INSTRUMENTS

Refer to section 4.1.3 to get information of above instrument.



4.5.4 TEST PROCEDURE

- a. The EUT was placed inside the environmental test chamber and powered by nominal DC voltage.
- b. Turn the EUT on and couple its output to a spectrum analyzer.
- c. Turn the EUT off and set the chamber to the highest temperature specified.
- d. Allow sufficient time (approximately 30 min) for the temperature of the chamber to stabilize, turn the EUT on and measure the operating frequency after 2, 5, and 10 minutes.
- e. Repeat step 2 and 3 with the temperature chamber set to the lowest temperature.
- f. The test chamber was allowed to stabilize at +20 degree C for a minimum of 30 minutes. The supply voltage was then adjusted on the EUT from 85% to 115% and the frequency record.

4.5.5 DEVIATION FROM TEST STANDARD

No deviation.

4.5.6 EUT OPERATING CONDITION

Set the EUT transmit at un-modulation mode to test frequency stability.



4.5.7 TEST RESULTS

FREQUENCY STABILITY VERSUS TEMP.									
OPERATING FREQUENCY: 5320MHz									
TEMP. (°C)	POWER SUPPLY (Vdc)	0 MINUTE		2 MINUTES		5 MINUTES		10 MINUTE	
		Measured Frequency (MHz)	Frequency Drift (%)	Measured Frequency (MHz)	Frequency Drift (%)	Measured Frequency (MHz)	Frequency Drift (%)	Measured Frequency (MHz)	Frequency Drift (%)
50	3.8	5320.0157	0.0002951	5320.0075	0.0001410	5320.0143	0.0002688	5320.0164	0.0003083
40	3.8	5320.0035	0.0000658	5319.9971	-0.0000545	5320.0042	0.0000789	5319.9985	-0.0000282
30	3.8	5319.9786	-0.0004023	5319.9854	-0.0002744	5319.9773	-0.0004267	5319.9862	-0.0002594
20	3.8	5319.9871	-0.0002425	5319.9812	-0.0003534	5319.9787	-0.0004004	5319.9805	-0.0003665
10	3.8	5319.9772	-0.0004286	5319.9778	-0.0004173	5319.9768	-0.0004361	5319.9743	-0.0004831
0	3.8	5320.0098	0.0001842	5320.0119	0.0002237	5320.0104	0.0001955	5320.0149	0.0002801
-10	3.8	5319.9883	-0.0002199	5319.9909	-0.0001711	5319.9818	-0.0003421	5319.9808	-0.0003609
-20	3.8	5320.0233	0.0004380	5320.0216	0.0004060	5320.0228	0.0004286	5320.0221	0.0004154
-30	3.8	5320.0038	0.0000714	5320.0046	0.0000865	5320.0025	0.0000470	5320.0011	0.0000207

FREQUENCY STABILITY VERSUS VOLTAGE									
OPERATING FREQUENCY: 5320MHz									
TEMP. (°C)	POWER SUPPLY (Vdc)	0 MINUTE		2 MINUTE		5 MINUTE		10 MINUTE	
		Measured Frequency (MHz)	Frequency Drift (%)	Measured Frequency (MHz)	Frequency Drift (%)	Measured Frequency (MHz)	Frequency Drift (%)	Measured Frequency (MHz)	Frequency Drift (%)
20	4.35	5319.9876	-0.0002331	5319.9808	-0.0003609	5319.9783	-0.0004079	5319.9824	-0.0003308
	3.8	5319.9871	-0.0002425	5319.9812	-0.0003534	5319.9787	-0.0004004	5319.9805	-0.0003665
	3.5	5319.9868	-0.0002481	5319.9802	-0.0003722	5319.9776	-0.0004211	5319.9816	-0.0003459



Test Report No.: RF140812N017-5

5. PHOTOGRAPHS OF THE TEST CONFIGURATION

Please refer to the attached file (Test Setup Photo).



Test Report No.: RF140812N017-5

6. APPENDIX A – MODIFICATIONS RECORDERS FOR ENGINEERING CHANGES TO THE EUT BY THE LAB

No modifications were made to the EUT by the lab during the test.

---END---