

FCC Test Report

Product Name : SkyCaddie
Model No. : Touch
FCC ID. : X8F-SCTOUCH

Applicant : SkyHawke Technologies, LLC
Address : 274 Commerce Park Drive, Ridgeland, Mississippi 39157 USA

Date of Receipt : 2014/02/17
Issued Date : 2014/10/16
Report No. : 1490372R-RFUSP01V00-A
Report Version : V1.0



The test results relate only to the samples tested.

The test report shall not be reproduced except in full without the written approval of Quietek Corporation.

Test Report Certification

Issued Date : 2014/10/16

Report No. : 1490372R-RFUSP01V00-A



Product Name : SkyCaddie
 Applicant : SkyHawke Technologies, LLC
 Address : 274 Commerce Park Drive, Ridgeland, Mississippi 39157 USA
 Manufacturer : Holux Technology, Inc.
 Model No. : Touch
 FCC ID. : X8F-SCTOUCH
 EUT Voltage : Mode 1: DC 5V (Power by PC)
 : Mode 2: AC100-240V, 50-60Hz
 : Mode 3: DC 3.7V (Power by Battery)
 Trade Name : SkyCaddie / SkyGolf
 Applicable Standard : FCC CFR Title 47 Part 15 Subpart C Section 15.247: 2013
 Test Result : Complied

The test results relate only to the samples tested.

The test report shall not be reproduced except in full without the written approval of Quietek Corporation.

Documented By : Fonbo Fang
 (Fonbo Fang / Engineering Adm. Assistant)
 Reviewed By : Sabrina Tsai
 (Sabrina Tsai / Engineer)
 Approved By : Roy Wang
 (Roy Wang / Director)

Laboratory Information

We, **Quietek Corporation**, are an independent RF consultancy that was established the whole facility in our laboratories. The test facility has been accredited/accepted (audited or listed) by the following related bodies in compliance with ISO 17025 specified testing scopes:

Taiwan R.O.C.	:	TAF, Accreditation Number: 1313 NCC, Certificate No: NCC-RCB-07
USA	:	FCC, Registration Number: 365520
Canada	:	IC, Submission No: 150981

The related certificate for our laboratories about the test site and management system can be downloaded from Quietek Corporation's Web Site:<http://www.quietek.com/tw/ctg/cts/accreditations.htm>

The address and introduction of Quietek Corporation's laboratories can be founded in our Web site : <http://www.quietek.com/>

If you have any comments, Please don't hesitate to contact us. Our contact information is as below:

HsinChu Testing Laboratory:

No.75-2, 3rd Lin, Wangye Keng, Yonghxing Tsuen, Qionglin Shiang, Hsinchu County 307, Taiwan, R.O.C.
TEL:+886-3-592-8858 / FAX:+886-3-592-8859 E-Mail : service@quietek.com

LinKou Testing Laboratory:

No.5-22, Ruishukeng, Linkou Dist., New Taipei City 24451, Taiwan, R.O.C.
TEL : 886-2-8601-3788 / FAX : 886-2-8601-3789 E-Mail : service@quietek.com

TABLE OF CONTENTS

Description	Page
1. General Information.....	6
1.1. EUT Description	6
1.2. Test Mode	8
1.3. Tested System Details	9
1.4. Configuration of tested System	10
1.5. EUT Exercise Software	11
1.6. Test Facility.....	12
2. Conducted Emission	13
2.1. Test Equipment.....	13
2.2. Test Setup	13
2.3. Limits	14
2.4. Test Procedure	14
2.5. Test Specification.....	14
2.6. Uncertainty	14
2.7. Test Result.....	15
2.8. Test Photo	19
3. Peak Power Output	21
3.1. Test Equipment.....	21
3.2. Test Setup	21
3.3. Test procedures	21
3.4. Limits	21
3.5. Test Specification.....	21
3.6. Test Result.....	22
4. Radiated Emission	28
4.1. Test Equipment.....	28
4.2. Test Setup	28
4.3. Limits	29
4.4. Test Procedure	29
4.5. Test Specification.....	29
4.6. Test Result.....	30
4.7. Test Photo	48
5. RF antenna conducted test	52
5.1. Test Equipment.....	52
5.2. Test Setup	52
5.3. Limits	53
5.4. Test Procedure	53
5.5. Test Specification.....	53
5.6. Test Result.....	54
6. Band Edge.....	84
6.1. Test Equipment.....	84
6.2. Test Setup	84

6.3.	Limits	85
6.4.	Test Procedure	85
6.5.	Test Specification.....	85
6.6.	Test Result.....	86
7.	Number of hopping frequency	102
7.1.	Test Equipment.....	102
7.2.	Test Setup	102
7.3.	Limits	103
7.4.	Test Procedures	103
7.5.	Test Specification.....	103
7.6.	Test Result.....	104
8.	Carrier Frequency Separation	108
8.1.	Test Equipment.....	108
8.2.	Test Setup	108
8.3.	Limits	108
8.4.	Test Procedures	108
8.5.	Test Specification.....	108
8.6.	Test Result.....	109
9.	Occupied Bandwidth	115
9.1.	Test Equipment.....	115
9.2.	Test Setup	115
9.3.	Limits	116
9.4.	Test Procedures	116
9.5.	Test Specification.....	116
9.6.	Test Result.....	117
10.	Dwell Time.....	123
10.1.	Test Equipment.....	123
10.2.	Test Setup	123
10.3.	Limits	124
10.4.	Test Procedures	124
10.5.	Test Specification.....	124
10.6.	Test Result.....	125
Attachement.....		133
	EUT Photograph.....	133

1. General Information

1.1. EUT Description

Product Name	SkyCaddie
Trade Name	SkyCaddie / SkyGolf
Model No.	Touch
Frequency Range/Channel Number	2402~2480MHz / 79 Channels
Type of Modulation	$\pi/4$ -DQPSK, 8-DQPSK
Antenna Type	Chip Antenna
Antenna Gain	0.2dBi

Component	
USB Cable	Shielded, 0.8m
Power Adapter	Saga Power, KSAS0060500100VUU I/P: 100-240V~50/60Hz, 0.18A O/P: 5.0V \equiv 1A

1TX1RX



Working Frequency of Each Channel							
Channel	Frequency	Channel	Frequency	Channel	Frequency	Channel	Frequency
Channel 00	2402 MHz	Channel 20	2422 MHz	Channel 40	2442 MHz	Channel 60	2462 MHz
Channel 01	2403 MHz	Channel 21	2423 MHz	Channel 41	2443 MHz	Channel 61	2463 MHz
Channel 02	2404 MHz	Channel 22	2424 MHz	Channel 42	2444 MHz	Channel 62	2464 MHz
Channel 03	2405 MHz	Channel 23	2425 MHz	Channel 43	2445 MHz	Channel 63	2465 MHz
Channel 04	2406 MHz	Channel 24	2426 MHz	Channel 44	2446 MHz	Channel 64	2466 MHz
Channel 05	2407 MHz	Channel 25	2427 MHz	Channel 45	2447 MHz	Channel 65	2467 MHz
Channel 06	2408 MHz	Channel 26	2428 MHz	Channel 46	2448 MHz	Channel 66	2468 MHz
Channel 07	2409 MHz	Channel 27	2429 MHz	Channel 47	2449 MHz	Channel 67	2469 MHz
Channel 08	2410 MHz	Channel 28	2430 MHz	Channel 48	2450 MHz	Channel 68	2470 MHz
Channel 09	2411 MHz	Channel 29	2431 MHz	Channel 49	2451 MHz	Channel 69	2471 MHz
Channel 10	2412 MHz	Channel 30	2432 MHz	Channel 50	2452 MHz	Channel 70	2472 MHz
Channel 11	2413 MHz	Channel 31	2433 MHz	Channel 51	2453 MHz	Channel 71	2473 MHz
Channel 12	2414 MHz	Channel 32	2434 MHz	Channel 52	2454 MHz	Channel 72	2474 MHz
Channel 13	2415 MHz	Channel 33	2435 MHz	Channel 53	2455 MHz	Channel 73	2475 MHz
Channel 14	2416 MHz	Channel 34	2436 MHz	Channel 54	2456 MHz	Channel 74	2476 MHz
Channel 15	2417 MHz	Channel 35	2437 MHz	Channel 55	2457 MHz	Channel 75	2477 MHz
Channel 16	2418 MHz	Channel 36	2438 MHz	Channel 56	2458 MHz	Channel 76	2478 MHz
Channel 17	2419 MHz	Channel 37	2439 MHz	Channel 57	2459 MHz	Channel 77	2479 MHz
Channel 18	2420 MHz	Channel 38	2440 MHz	Channel 58	2460 MHz	Channel 78	2480 MHz
Channel 19	2421 MHz	Channel 39	2441 MHz	Channel 59	2461 MHz		

Note:

1. This device is a SkyCaddie including a 2.4GHz receiving function, and transmitting function.
2. These test results on a sample of the equipment for the purpose of demonstrating compliance with Part 15 Subpart C Paragraph 15.247 for spread spectrum devices.
3. Regards to the frequency band operation; the lowest , middle and highest frequency of channel were selected to perform the test, and then shown on this report.
4. This device is a composite device in accordance with Part 15 regulations. The function receiving was measured and made a test report that the report number is 1490372R-RFUSP01V00 .

1.2. Test Mode

QuieTek has verified the construction and function in typical operation. All the test modes were carried out with the EUT in transmitting operation, which was shown in this test report and defined as follows:

Pre-Test Mode	
TX	Mode 1: Transmit (Power by PC) Mode 2: Transmit (Power by Adapter) Mode 3: Transmit (Power by Battery)
Final Test Mode	
TX	Mode 1: Transmit (Power by PC) Mode 2: Transmit (Power by Adapter) Mode 3: Transmit (Power by Battery)

Emission	Mode 1	Mode 2	Mode 3
Conducted Emission	No	Yes	Yes
Peak Power Output	Yes	No	No
Radiated Emission	Yes	Yes	Yes
RF antenna conducted test	Yes	No	No
Band Edge	Yes	No	No
Number of hopping Frequency	Yes	No	No
Carrier Frequency Separation	Yes	No	No
Occupied Bandwidth	Yes	No	No
Dwell Time	Yes	No	No

1.3. Tested System Details

The types for all equipments, plus descriptions of all cables used in the tested system (including inserted cards) are:

Test Mode		Mode 1: Transmit (Power by PC)				
Product		Manufacturer	Model No.	Serial No.	FCC ID	Power Cord
1	Notebook PC	HP	HSTNN-146C	8253S1X	DoC	Non-Shielded, 1.8m
2	Fixture	Holux	N/A	N/A	DoC	--
3	Monitor	DELL	U2410f	082WXD-72872-16R-0V7L	DoC	Non-Shielded, 1.8m
4	Microphone & Earphone	Fujiei	SBZ-38	N/A	DoC	--

Test Mode		Mode 2: Transmit (Power by Adapter) Mode 3: Transmit (Power by Battery)				
Product		Manufacturer	Model No.	Serial No.	FCC ID	Power Cord
1	Monitor	DELL	U2410f	082WXD-72872-16R-0W2L	DoC	Non-Shielded, 1.8m
2	Fixture	Holux	N/A	N/A	DoC	--

1.4. Configuration of tested System

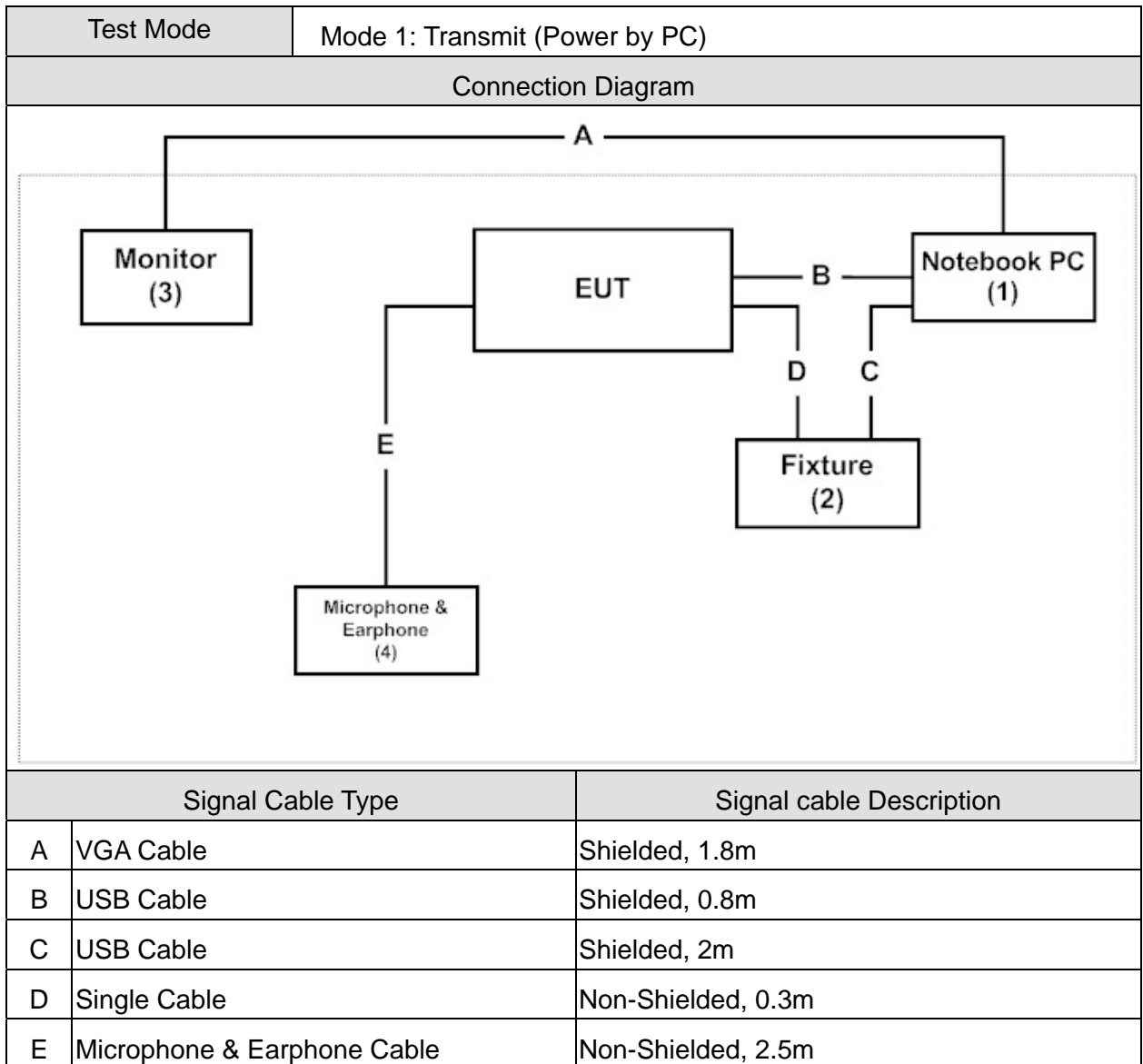

Test Mode	Mode 2: Transmit (Power by Adapter) Mode 3: Transmit (Power by Battery)	
Connection Diagram		
<pre> graph LR EUT[EUT] --- B[B] --- Fixture2[Fixture (2)] Fixture2 --- A[A] --- NotebookPC[Notebook PC (1)] </pre>		
Signal Cable Type		Signal cable Description
A	USB Cable	Shielded, 2m
B	Single Cable	Non-Shielded, 0.3m

1.5. EUT Exercise Software

1	Setup the EUT as shown in Section 1.5
2	Execute the “CSR Blue Suite3” which is installed on the Notebook.
3	Configure the test mode, the test channel to start the continuous Receiver
4	Press “Start TX to start the continuous transmitting
5	Verify that the EUT works properly.

1.6. Test Facility

Ambient conditions in the laboratory:

Items	Test Item	Required (IEC 68-1)	Actual
Temperature (°C)	FCC PART 15 C 15.207 Conducted Emission (FHSS)	15 - 35	23
Humidity (%RH)		25 - 75	50
Barometric pressure (mbar)		860 - 1060	950-1000
Temperature (°C)	FCC PART 15 C 15.247 Peak Power Output (FHSS)	15 - 35	23
Humidity (%RH)		25 - 75	50
Barometric pressure (mbar)		860 - 1060	950-1000
Temperature (°C)	FCC PART 15 C 15.247 Radiated Emission (FHSS)	15 - 35	25
Humidity (%RH)		25 - 75	54
Barometric pressure (mbar)		860 - 1060	950-1000
Temperature (°C)	FCC PART 15 C 15.247 Band Edge (FHSS)	15 - 35	25
Humidity (%RH)		25 - 75	50
Barometric pressure (mbar)		860 - 1060	950-1000
Temperature (°C)	FCC PART 15 C 15.247 Number of hopping Frequency (FHSS)	15 - 35	23
Humidity (%RH)		25 - 75	50
Barometric pressure (mbar)		860 - 1060	950-1000
Temperature (°C)	FCC PART 15 C 15.247 Carrier Frequency Separation (FHSS)	15 - 35	23
Humidity (%RH)		25 - 75	50
Barometric pressure (mbar)		860 - 1060	950-1000
Temperature (°C)	FCC PART 15 C 15.247 Occupied Bandwidth (FHSS)	15 - 35	24
Humidity (%RH)		25 - 75	48
Barometric pressure (mbar)		860 - 1060	950-1000
Temperature (°C)	FCC PART 15 C 15.247 RF antenna conducted test (FHSS)	15 - 35	24
Humidity (%RH)		25 - 75	48
Barometric pressure (mbar)		860 - 1060	950-1000
Temperature (°C)	FCC PART 15 C 15.247 Dwell Time (FHSS)	15 - 35	23
Humidity (%RH)		25 - 75	50
Barometric pressure (mbar)		860 - 1060	950-1000

2. Conducted Emission

2.1. Test Equipment

The following test equipments are used during the test:

Conducted Emission / SR2

Instrument	Manufacturer	Model No.	Serial No	Next Cal. Date
Artificial Mains Network	R&S	ENV4200	848411/010	2015/02/09
LISN	R&S	ENV216	100092	2015/08/24
Test Receiver	R&S	ESCS 30	825442/014	2015/07/13

Note: 1. All equipments that need to calibrate are with calibration period of 1 year.

2.2. Test Setup

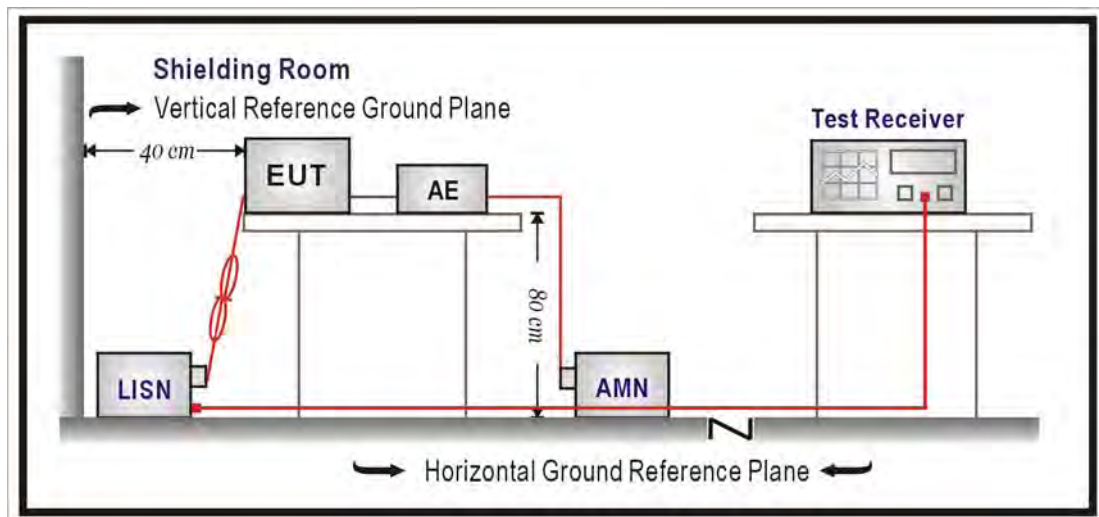

2.3. Limits

FCC Part 15 Subpart C Paragraph 15.207 Limits (dBuV)		
Frequency MHz	QP	AV
0.15 - 0.50	66-56	56-46
0.50 - 5.0	56	46
5.0 - 30	60	50

Remarks: In the above table, the tighter limit applies at the band edges.

2.4. Test Procedure

The EUT and simulators are connected to the main power through a line impedance stabilization network (L.I.S.N.). This provides a 50 ohm /50uH coupling impedance for the measuring equipment. The peripheral devices are also connected to the main power through a LISN that provides a 50ohm /50uH coupling impedance with 50ohm termination. (Please refer to the block diagram of the test setup and photographs.)

Both sides of A.C. line are checked for maximum conducted interference. In order to find the maximum emission, the relative positions of equipment and all of the interface cables must be changed according to ANSI C63.10 on conducted measurement.

Conducted emissions were investigated over the frequency range from 0.15MHz to 30MHz using a receiver bandwidth of 9 kHz.

2.5. Test Specification

According to FCC Part 15 Subpart C Paragraph 15.207: 2013

2.6. Uncertainty

The measurement uncertainty is defined as ± 2.26 dB.

2.7. Test Result

Site : SR2	Time : 2014/10/01 - 10:36
Limit : CISPR_B_00M_QP	Margin : 10
Probe : SR2_LISN(16A)-5_0825 - Line1	Power : AC 120V 60Hz
EUT : SkyCaddie	Note : Mode 1: Transmit (Power by PC)_2441MHz

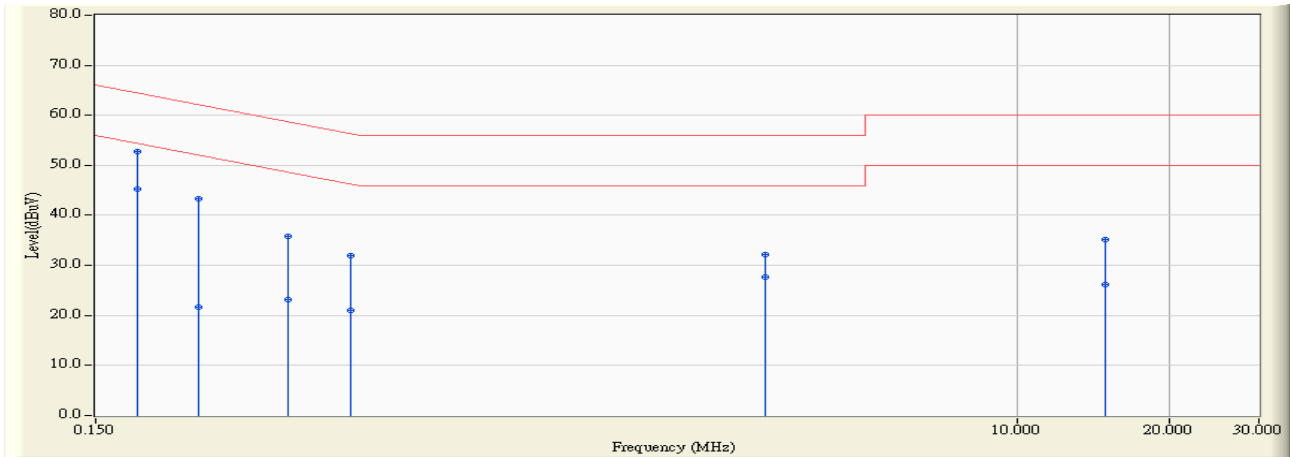

	Frequency (MHz)	Correct Factor (dB)	Reading Level (dBuV)	Measure Level (dBuV)	Margin (dB)	Limit (dBuV)	Detector Type
1	0.181	9.760	43.080	52.840	-11.588	64.428	QUASPEAK
2	* 0.181	9.760	35.590	45.350	-9.078	54.428	AVERAGE
3	0.240	9.758	33.520	43.278	-18.824	62.102	QUASPEAK
4	0.240	9.758	11.980	21.738	-30.364	52.102	AVERAGE
5	0.361	9.752	26.000	35.752	-22.955	58.707	QUASPEAK
6	0.361	9.752	13.510	23.262	-25.445	48.707	AVERAGE
7	0.478	9.751	22.210	31.961	-24.410	56.372	QUASPEAK
8	0.478	9.751	11.180	20.931	-25.440	46.372	AVERAGE
9	3.173	9.915	22.360	32.275	-23.725	56.000	QUASPEAK
10	3.173	9.915	17.820	27.735	-18.265	46.000	AVERAGE
11	14.939	10.234	25.040	35.274	-24.726	60.000	QUASPEAK
12	14.939	10.234	15.850	26.084	-23.916	50.000	AVERAGE

Note:

1. All Reading Levels are Quasi-Peak and average value.
2. " * ", means this data is the worst emission level.
3. Measurement Level = Reading Level + Correct Factor.

Site : SR2	Time : 2014/10/01 - 10:39
Limit : CISPR_B_00M_QP	Margin : 10
Probe : SR2_LISN(16A)-5_0825 - Line2	Power : AC 120V 60Hz
EUT : SkyCaddie	Note : Mode 1: Transmit (Power by PC)_2441MHz

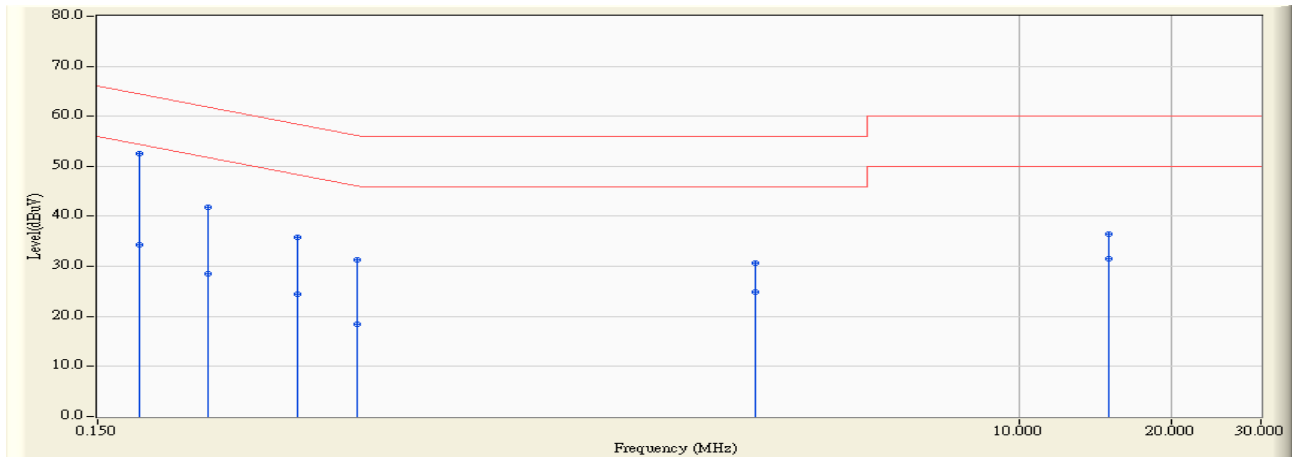

		Frequency (MHz)	Correct Factor (dB)	Reading Level (dBuV)	Measure Level (dBuV)	Margin (dB)	Limit (dBuV)	Detector Type
1	*	0.181	9.810	42.770	52.580	-11.849	64.429	QUASPEAK
2		0.181	9.810	24.600	34.410	-20.019	54.429	AVERAGE
3		0.248	9.812	32.100	41.912	-19.923	61.835	QUASPEAK
4		0.248	9.812	18.760	28.572	-23.263	51.835	AVERAGE
5		0.373	9.819	26.100	35.919	-22.523	58.442	QUASPEAK
6		0.373	9.819	14.710	24.529	-23.913	48.442	AVERAGE
7		0.490	9.820	21.460	31.280	-24.890	56.170	QUASPEAK
8		0.490	9.820	8.620	18.440	-27.730	46.170	AVERAGE
9		3.002	9.973	20.600	30.573	-25.427	56.000	QUASPEAK
10		3.002	9.973	15.000	24.973	-21.027	46.000	AVERAGE
11		15.021	10.375	26.160	36.536	-23.464	60.000	QUASPEAK
12		15.021	10.375	21.170	31.546	-18.454	50.000	AVERAGE

Note:

1. All Reading Levels are Quasi-Peak and average value.
2. " * ", means this data is the worst emission level.
3. Measurement Level = Reading Level + Correct Factor.

Site : SR2	Time : 2014/10/01 - 10:54
Limit : CISPR_B_00M_QP	Margin : 10
Probe : SR2_LISN(16A)-5_0825 - Line1	Power : DC 3.7V (Power by Battery)
EUT : SkyCaddie	Note : Mode 2: Transmit (Power by Adapter)_2441MHz

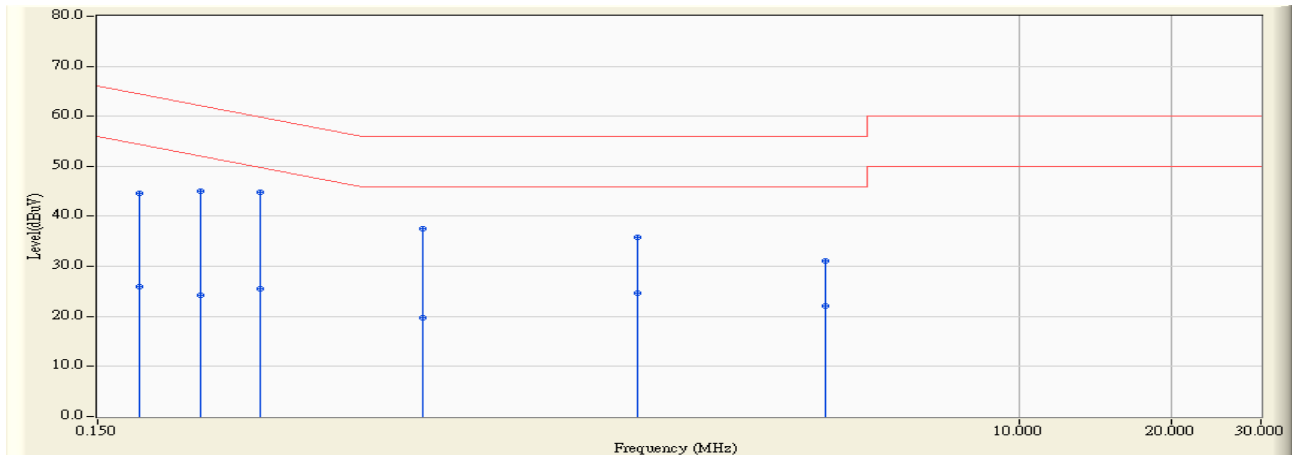

	Frequency (MHz)	Correct Factor (dB)	Reading Level (dBuV)	Measure Level (dBuV)	Margin (dB)	Limit (dBuV)	Detector Type
1	0.181	9.760	34.920	44.680	-19.748	64.428	QUASPEAK
2	0.181	9.760	16.240	26.000	-28.428	54.428	AVERAGE
3	0.240	9.758	35.190	44.948	-17.154	62.102	QUASPEAK
4	0.240	9.758	14.510	24.268	-27.834	52.102	AVERAGE
5	* 0.314	9.754	34.990	44.744	-15.118	59.862	QUASPEAK
6	0.314	9.754	15.850	25.604	-24.258	49.862	AVERAGE
7	0.662	9.786	27.820	37.607	-18.393	56.000	QUASPEAK
8	0.662	9.786	10.020	19.807	-26.193	46.000	AVERAGE
9	1.759	9.868	25.910	35.778	-20.222	56.000	QUASPEAK
10	1.759	9.868	14.740	24.608	-21.392	46.000	AVERAGE
11	4.138	9.952	21.180	31.132	-24.868	56.000	QUASPEAK
12	4.138	9.952	12.180	22.132	-23.868	46.000	AVERAGE

Note:

1. All Reading Levels are Quasi-Peak and average value.
2. " * ", means this data is the worst emission level.
3. Measurement Level = Reading Level + Correct Factor.

Site : SR2	Time : 2014/10/01 - 10:56
Limit : CISPR_B_00M_QP	Margin : 10
Probe : SR2_LISN(16A)-5_0825 - Line2	Power : DC 3.7V (Power by Battery)
EUT : SkyCaddie	Note : Mode 2: Transmit (Power by Adapter)_2441MHz

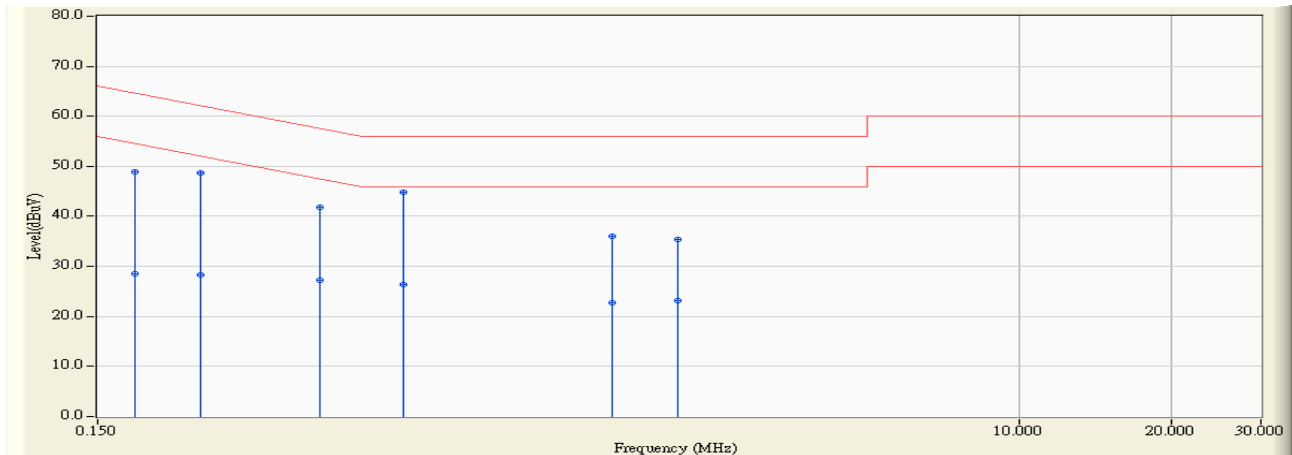

	Frequency (MHz)	Correct Factor (dB)	Reading Level (dBuV)	Measure Level (dBuV)	Margin (dB)	Limit (dBuV)	Detector Type
1	0.177	9.810	39.110	48.920	-15.689	64.609	QUASPEAK
2	0.177	9.810	18.770	28.580	-26.029	54.609	AVERAGE
3	0.240	9.812	38.860	48.672	-13.430	62.102	QUASPEAK
4	0.240	9.812	18.510	28.322	-23.780	52.102	AVERAGE
5	0.412	9.820	32.030	41.850	-15.764	57.614	QUASPEAK
6	0.412	9.820	17.380	27.200	-20.414	47.614	AVERAGE
7	* 0.603	9.840	34.960	44.800	-11.200	56.000	QUASPEAK
8	0.603	9.840	16.620	26.460	-19.540	46.000	AVERAGE
9	1.560	9.926	26.090	36.016	-19.984	56.000	QUASPEAK
10	1.560	9.926	12.740	22.666	-23.334	46.000	AVERAGE
11	2.111	9.935	25.370	35.305	-20.695	56.000	QUASPEAK
12	2.111	9.935	13.300	23.235	-22.765	46.000	AVERAGE

Note:

1. All Reading Levels are Quasi-Peak and average value.
2. " * ", means this data is the worst emission level.
3. Measurement Level = Reading Level + Correct Factor.

3. Peak Power Output

3.1. Test Equipment

The following test equipment is used during the test:

Peak Power Output / SR7

Instrument	Manufacturer	Model No.	Serial No	Next Cal. Date
Spectrum Analyzer	Agilent	N9010A-EXA	US47140172	2015/07/14

Note: All equipment upon which need to calibrated are with calibration period of 1 year.

3.2. Test Setup

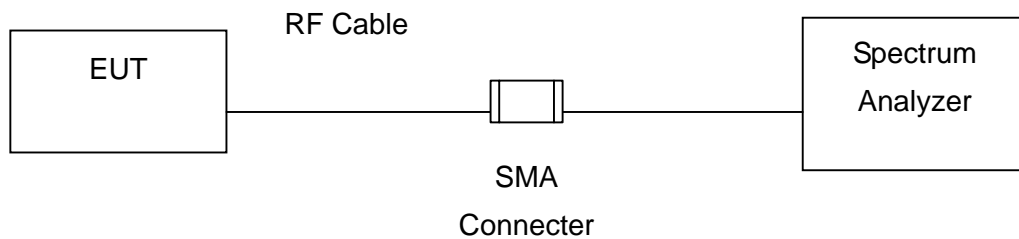

3.3. Test procedures

The EUT was setup according to ANSI C63.10 and tested according to FHSS test procedure of FCC Public Notice DA 00-705 for compliance to FCC 47CFR 15.247 requirements

3.4. Limits

For frequency hopping systems operating in the 902-928 MHz band: 1 Watt for systems employing at least 50 hopping channels; and, 0.25 Watts for systems employing less than 50 hopping channels.

For frequency hopping systems in the 2400-2483.5 MHz band employing at least 75 hopping channels, and all frequency hopping systems in the 5725-5850 MHz band: 1Watt. For all other frequency hopping systems in the 2400-2483.5 MHz band: 0.125 Watt.

3.5. Test Specification

According to FCC Part 15 Subpart C Paragraph 15.247: 2013

3.6. Test Result

Product	SkyCaddie		
Test Item	Peak Power Output		
Test Mode	Mode 1: Transmit (Power by PC)		
Date of Test	2014/06/13	Test Site	SR7

$\pi/4$ -DQPSK

Channel No.	Frequency (MHz)	Measure Level (dBm)	Limit (dBm)	Result
00	2402	-5.400	30	Pass

Channel 00

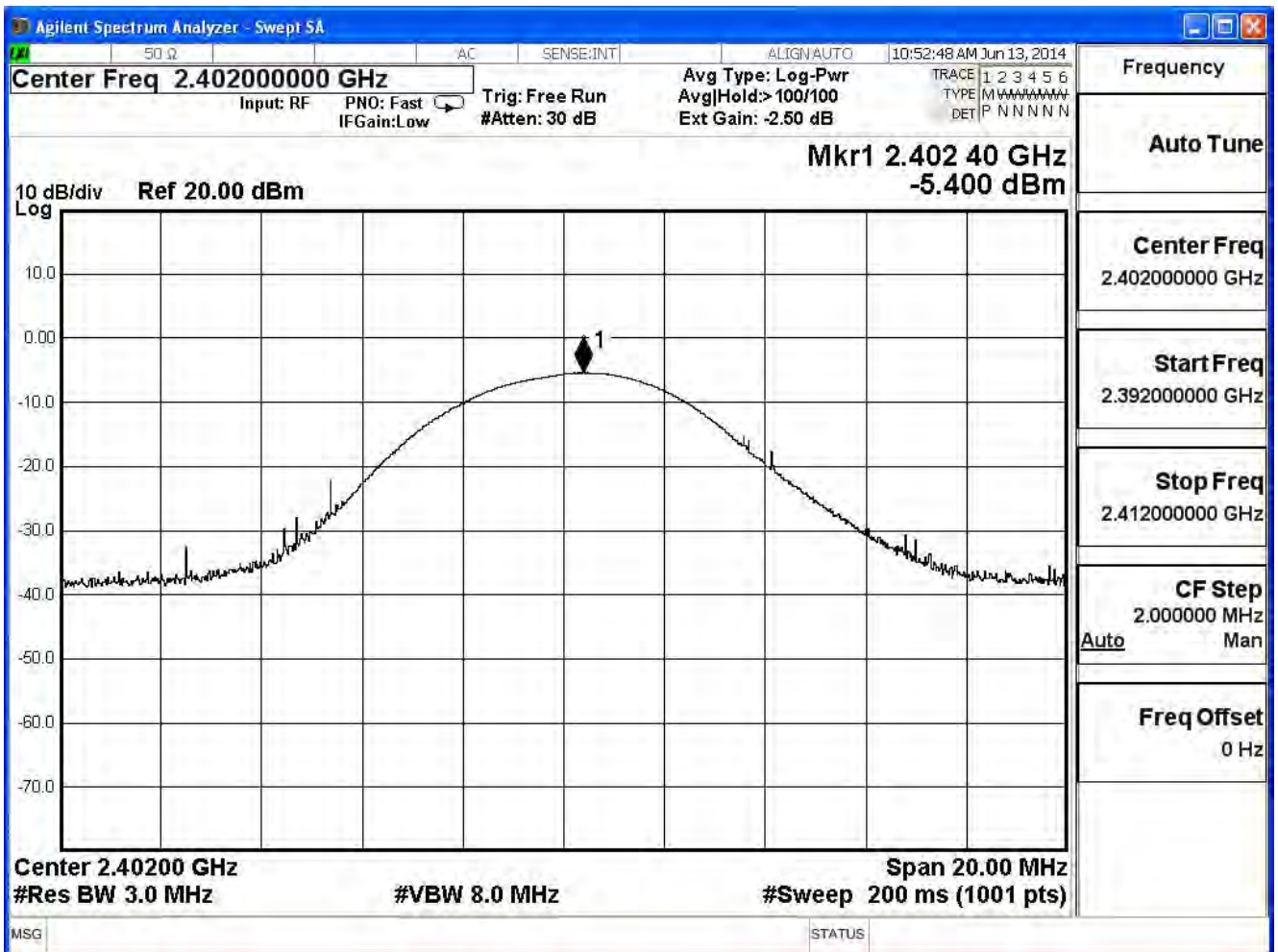

Product	SkyCaddie		
Test Item	Peak Power Output		
Test Mode	Mode 1: Transmit (Power by PC)		
Date of Test	2014/06/13	Test Site	SR7

$\pi/4$ -DQPSK

Channel No.	Frequency (MHz)	Measure Level (dBm)	Limit (dBm)	Result
39	2441	-2.110	30	Pass

Channel 39

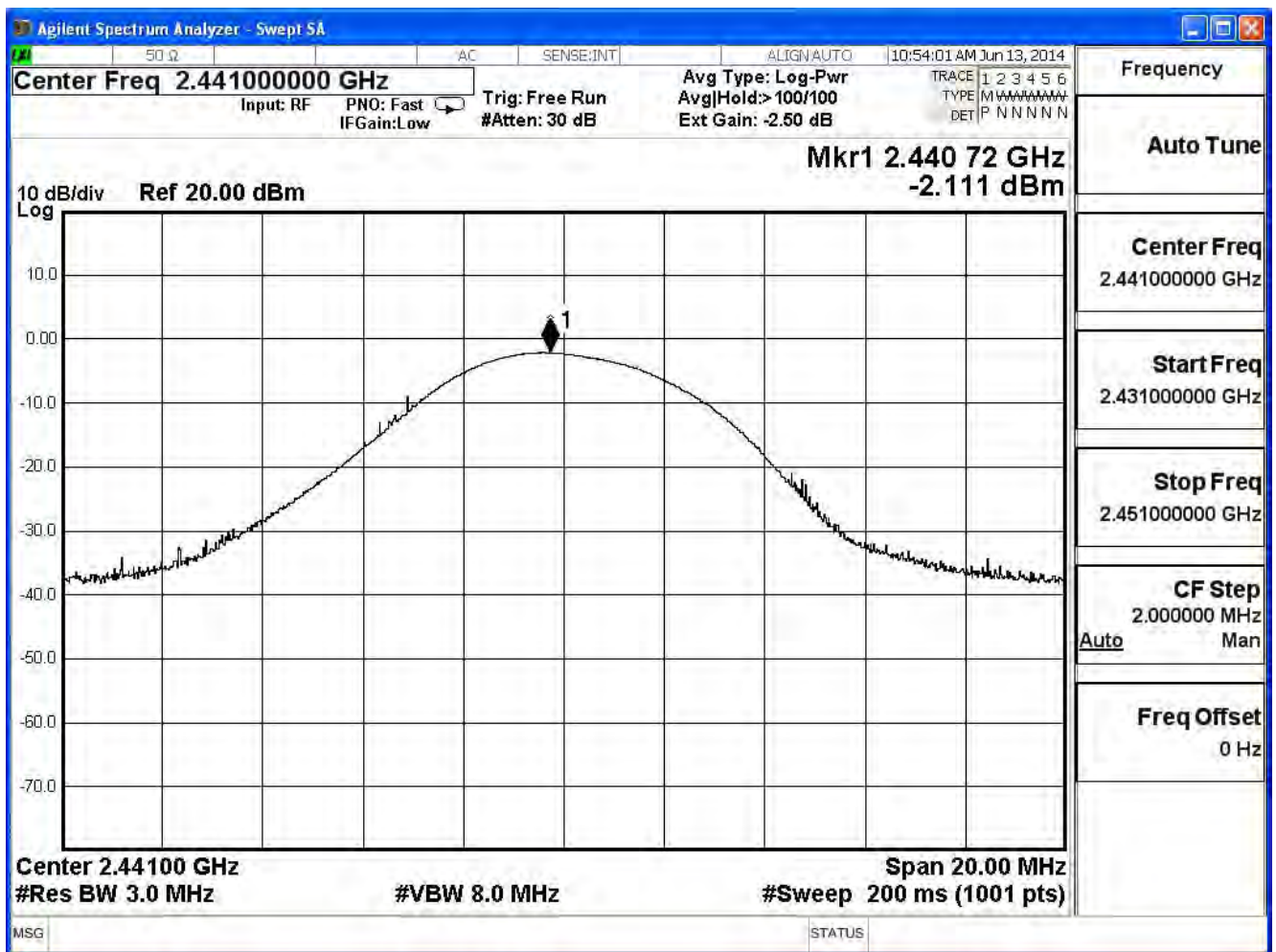

Product	SkyCaddie		
Test Item	Peak Power Output		
Test Mode	Mode 1: Transmit (Power by PC)		
Date of Test	2014/06/13	Test Site	SR7

$\pi/4$ -DQPSK

Channel No.	Frequency (MHz)	Measure Level (dBm)	Limit (dBm)	Result
78	2480	-0.309	30	Pass

Channel 78

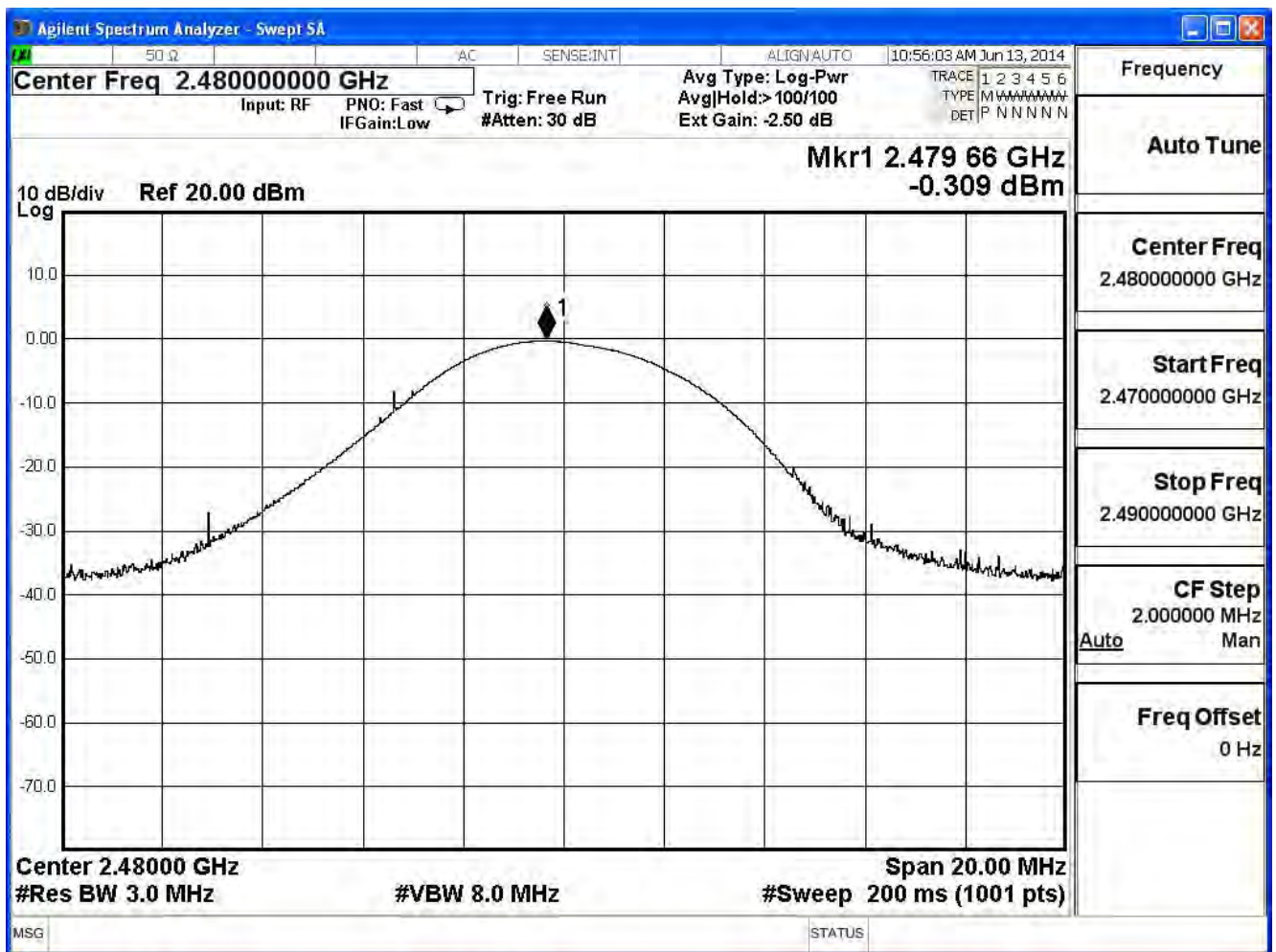

Product	SkyCaddie		
Test Item	Peak Power Output		
Test Mode	Mode 1: Transmit (Power by PC)		
Date of Test	2014/06/13	Test Site	SR7

8-DQPSK

Channel No.	Frequency (MHz)	Measure Level (dBm)	Limit (dBm)	Result
00	2402	-5.407	30	Pass

Channel 00

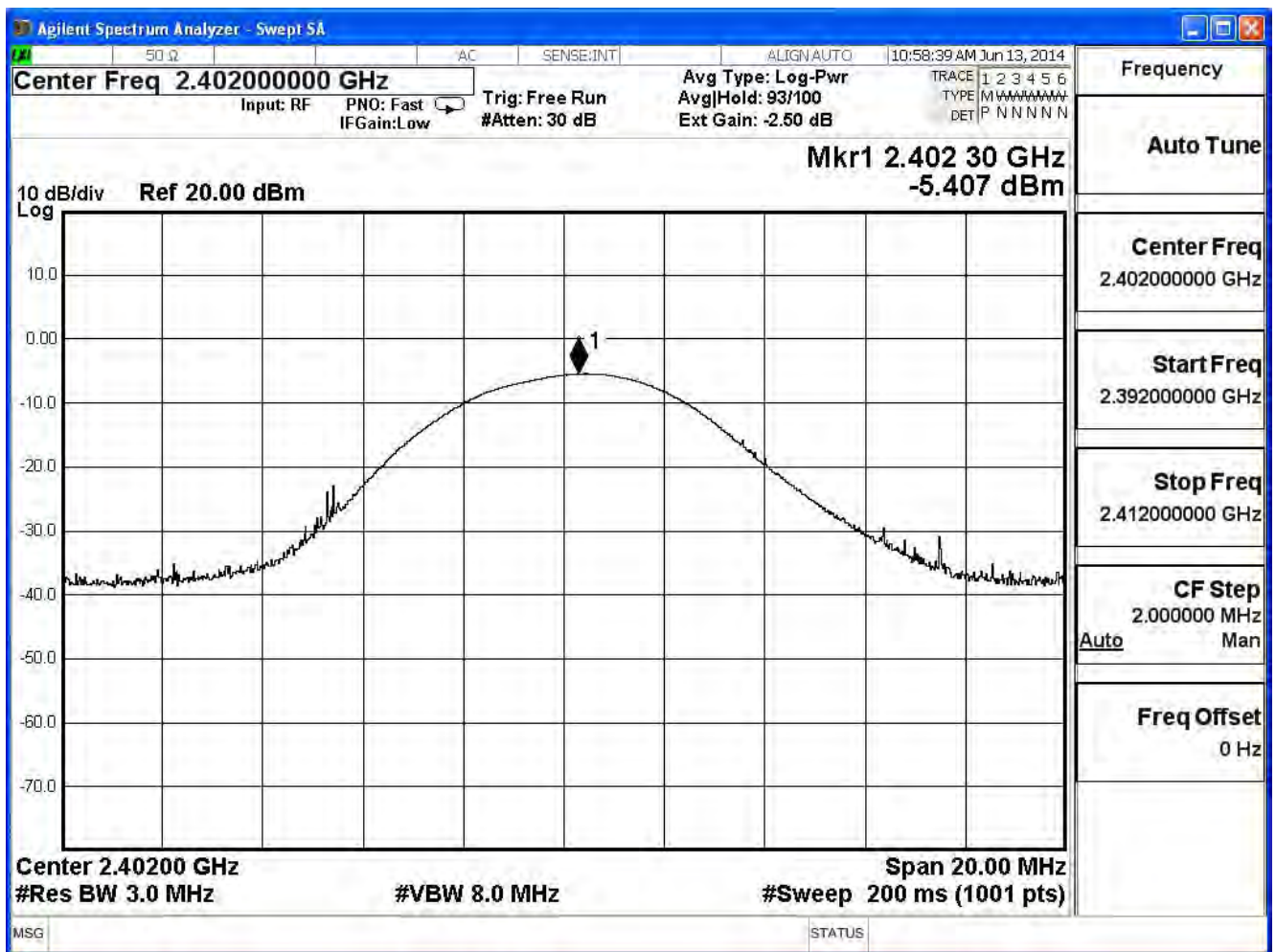

Product	SkyCaddie		
Test Item	Peak Power Output		
Test Mode	Mode 1: Transmit (Power by PC)		
Date of Test	2014/06/13	Test Site	SR7

8-DQPSK

Channel No.	Frequency (MHz)	Measure Level (dBm)	Limit (dBm)	Result
39	2441	-2.138	30	Pass

Channel 39

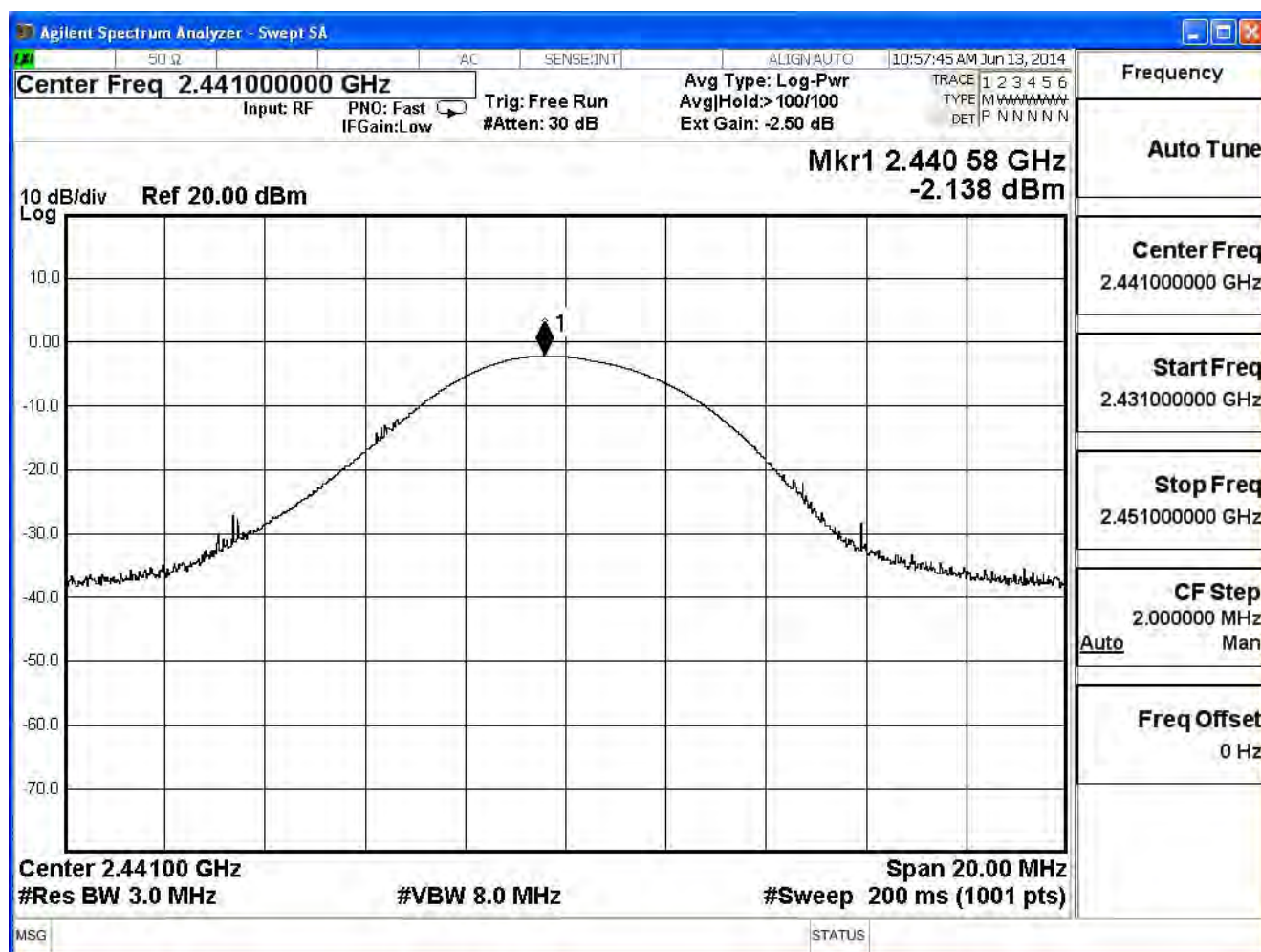

Product	SkyCaddie		
Test Item	Peak Power Output		
Test Mode	Mode 1: Transmit (Power by PC)		
Date of Test	2014/06/13	Test Site	SR7

8-DQPSK

Channel No.	Frequency (MHz)	Measure Level (dBm)	Limit (dBm)	Result
78	2480	-0.264	30	Pass

Channel 78

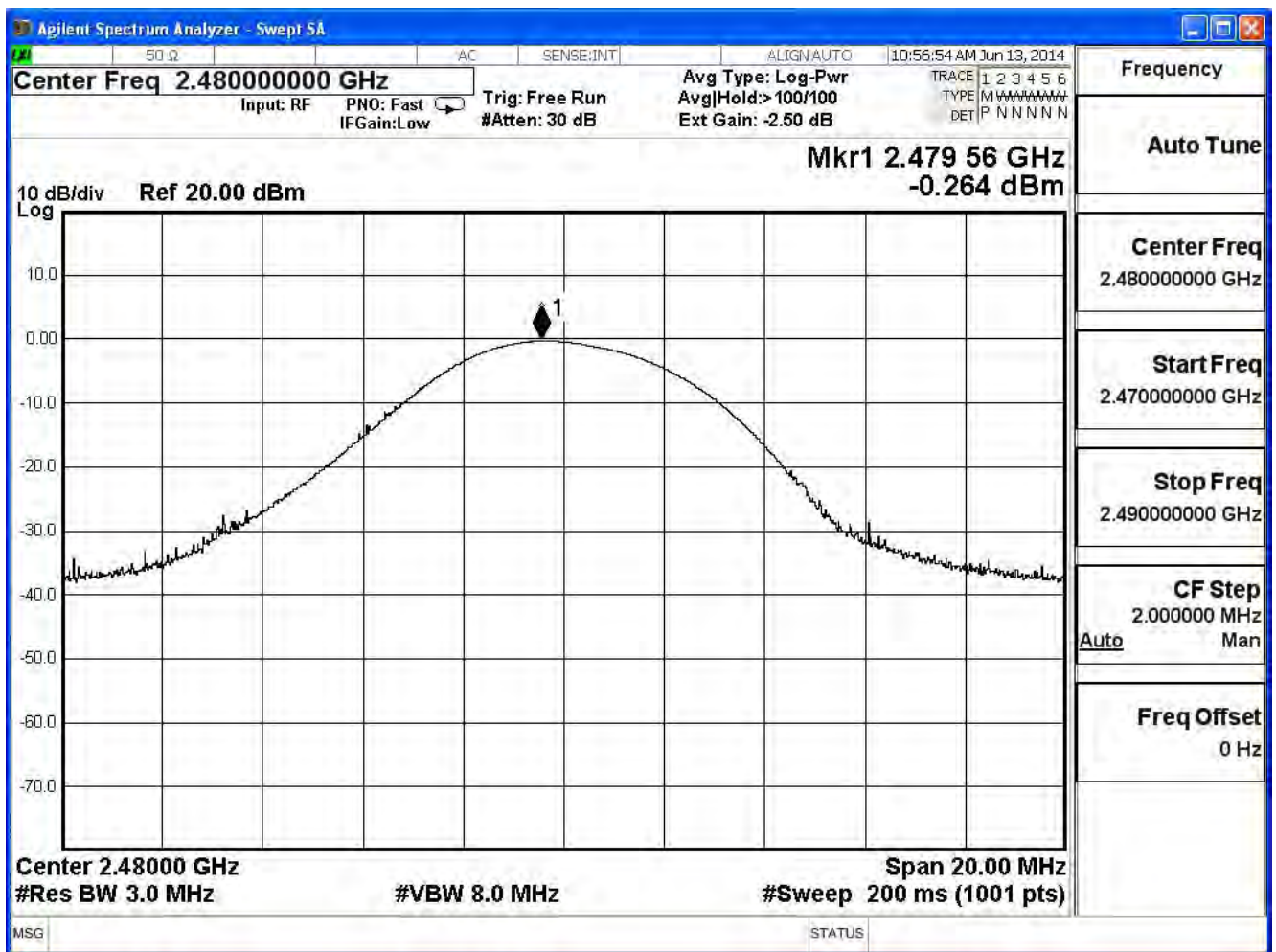

4. Radiated Emission

4.1. Test Equipment

The following test equipments are used during the test:

Radiated Emission / CB1

Instrument	Manufacturer	Model No.	Serial No	Next Cal. Date
Bilog Antenna	SCHAFFNER	CBL6112B	2895(CB1)	2015/08/14
Double Ridged Guide Horn Antenna	Schwarzback	BBHA 9120	D743	2015/02/12
Pre-Amplifier	Quietek	AMF-4D.	888003	2015/06/02
Pre-Amplifier	Quietek	AP-025C	CHM-0706049	2015/02/06
Spectrum Analyzer	Agilent	E4440A	MY46187335	2015/01/12
k Type Cable	Huber Suhner	Sucoflex 102	25623/2	2015/02/10

Note: 1. All equipments that need to calibrate are with calibration period of 1 year.

4.2. Test Setup

Under 1GHz Test Setup:

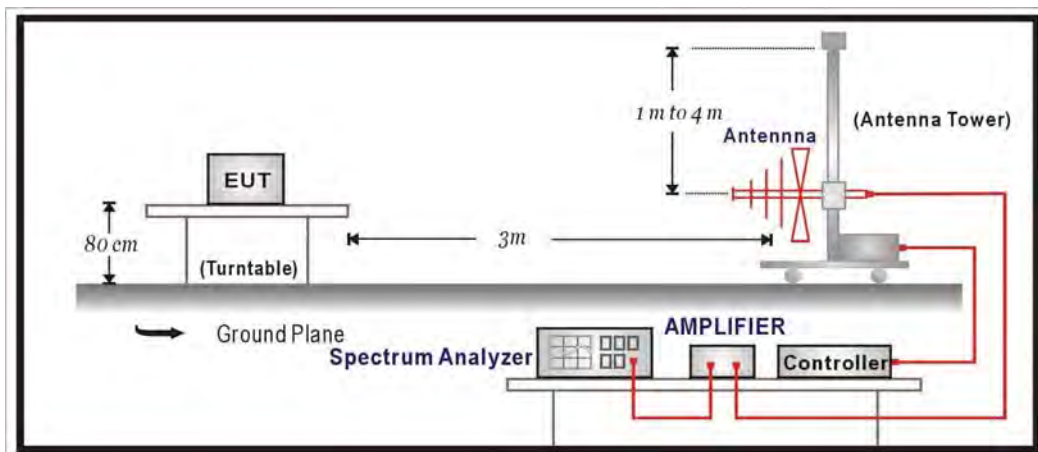

Above 1GHz Test Setup:

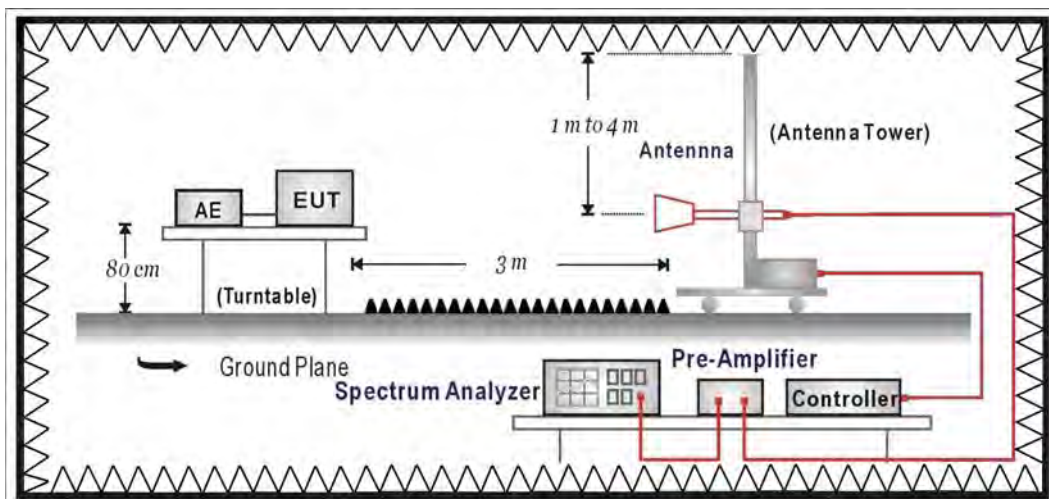

4.3. Limits

Emissions radiated outside of the specified frequency bands, except for harmonics, shall be attenuated by at least 20dB below the level of the fundamental or to the general radiated emission limits in paragraph 15.209, whichever is the lesser attenuation.

FCC Part 15 Subpart C Paragraph 15.209 Limits		
Frequency MHz	uV/m	dBuV/m
30-88	100	40
88-216	150	43.5
216-960	200	46
Above 960	500	54

- Remarks :
1. RF Voltage (dBuV) = 20 log RF Voltage (uV)
 2. In the Above Table, the tighter limit applies at the band edges.
 3. Distance refers to the distance in meters between the measuring instrument antenna and the closed point of any part of the device or system.

4.4. Test Procedure

The EUT was setup according to ANSI C63.10 and tested according to FHSS test procedure of FCC Public Notice DA 00-705 for compliance to FCC 47CFR 15.247 requirements.

The EUT and its simulators are placed on a turn table which is 0.8 meter above ground. The turn table can rotate 360 degrees to determine the position of the maximum emission level. The antenna can move up and down between 1 meter and 4 meters to find out the maximum emission level.

Both horizontal and vertical polarization of the antenna are set on measurement. In order to find the maximum emission, all of the interface cables must be manipulated according to ANSI C63.10 on radiated measurement.

On any frequency or frequencies below or equal to 1000 MHz, the limits shown are based on measuring equipment employing a quasi-peak detector function and on any frequency or frequencies above 1000 MHz the radiated limits shown are based upon the use of measurement instrumentation employing an average detector function. When average radiated emission measurement are included emission measurement below 1000 MHz, there also is a limit on the radio frequency emissions, as measured using instrumentation with a peak detector function, corresponding to 20 dB above the maximum permitted average limit. The bandwidth below 1GHz setting on the field strength meter is 120 kHz and above 1GHz is 1MHz.

4.5. Test Specification

According to FCC Part 15 Subpart C Paragraph 15.247: 2013

4.6. Test Result

30MHz-1GHz Spurious

Site : CB3	Time : 2014/10/15 - 15:30
Limit : FCC_CLASS_B_03M_QP	Margin : 6
Probe : CB3_FCC_EFS_30-1G-1_0901 - HORIZONTAL	Power : DC5V(Power by PC)
EUT : SkyCaddie	Note : Mode 1: Transmit (Power by PC)_ 2441MHz

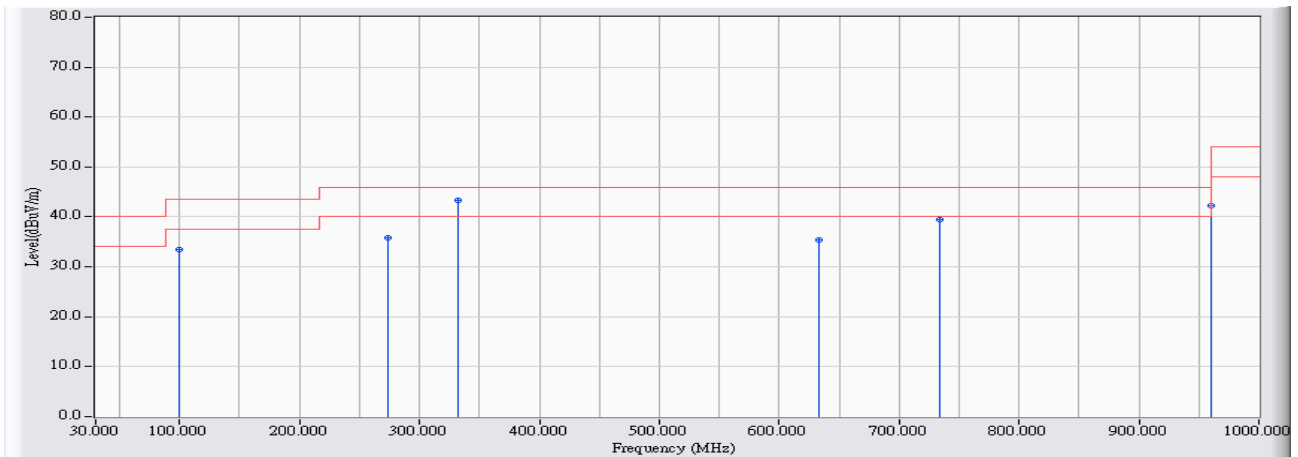

	Frequency (MHz)	Correct Factor (dB)	Reading Level (dBuV)	Measure Level (dBuV/m)	Margin (dB)	Limit (dBuV/m)	Detector Type
1	99.840	-29.634	62.994	33.360	-10.140	43.500	QUASPEAK
2	273.470	-26.869	62.646	35.777	-10.223	46.000	QUASPEAK
3	* 332.155	-25.479	68.823	43.343	-2.657	46.000	QUASPEAK
4	633.340	-20.890	56.181	35.291	-10.709	46.000	QUASPEAK
5	733.250	-20.194	59.604	39.410	-6.590	46.000	QUASPEAK
6	960.230	-17.682	59.849	42.168	-11.832	54.000	QUASPEAK

Note:

1. All Reading Levels are Quasi-Peak value.
2. “ * ”, means this data is the worst emission level.
3. Measurement Level = Reading Level + Correct Factor

Site : CB3	Time : 2014/10/15 - 15:42
Limit : FCC_CLASS_B_03M_QP	Margin : 6
Probe : CB3_FCC_EFS_30-1G-1_0901 - VERTICAL	Power : DC5V(Power by PC)
EUT : SkyCaddie	Note : Mode 1: Transmit (Power by PC)_ 2441MHz

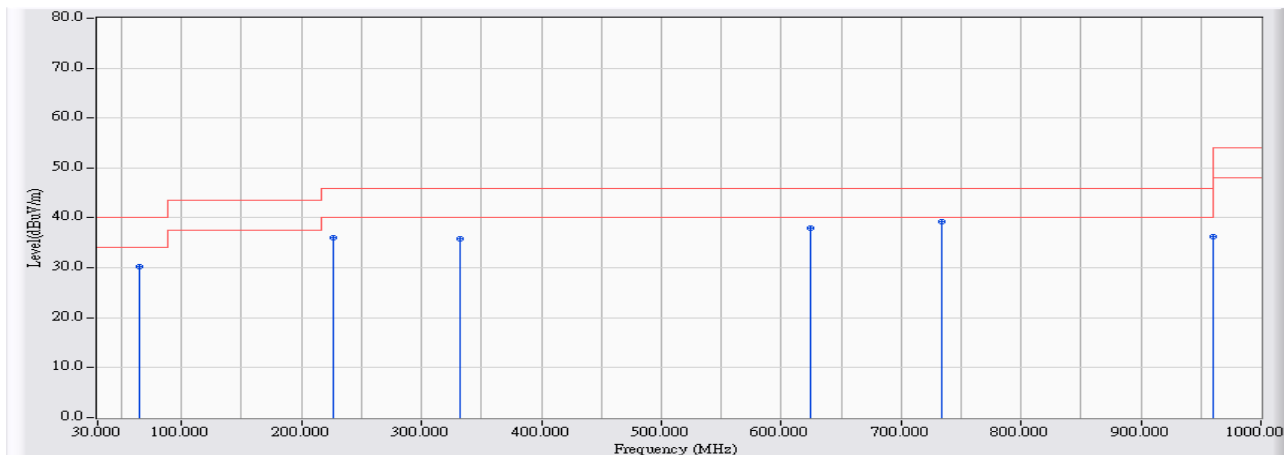

	Frequency (MHz)	Correct Factor (dB)	Reading Level (dBuV)	Measure Level (dBuV/m)	Margin (dB)	Limit (dBuV/m)	Detector Type
1	64.435	-33.757	63.948	30.191	-9.809	40.000	QUASPEAK
2	225.940	-29.210	65.301	36.090	-9.910	46.000	QUASPEAK
3	332.155	-25.479	61.384	35.904	-10.096	46.000	QUASPEAK
4	624.125	-20.862	58.908	38.046	-7.954	46.000	QUASPEAK
5	* 733.250	-20.194	59.505	39.311	-6.689	46.000	QUASPEAK
6	960.230	-17.682	54.011	36.330	-17.670	54.000	QUASPEAK

Note:

1. All Reading Levels are Quasi-Peak value.
2. “ * ”, means this data is the worst emission level.
3. Measurement Level = Reading Level + Correct Factor

Site : CB3	Time : 2014/10/15 - 15:57
Limit : FCC_CLASS_B_03M_QP	Margin : 6
Probe : CB3_FCC_EFS_30-1G-1_0901 - HORIZONTAL	Power : AC 120V / 60Hz
EUT : SkyCaddie	Note : Mode 2: Transmit (Power by Adapter)_2441MHz

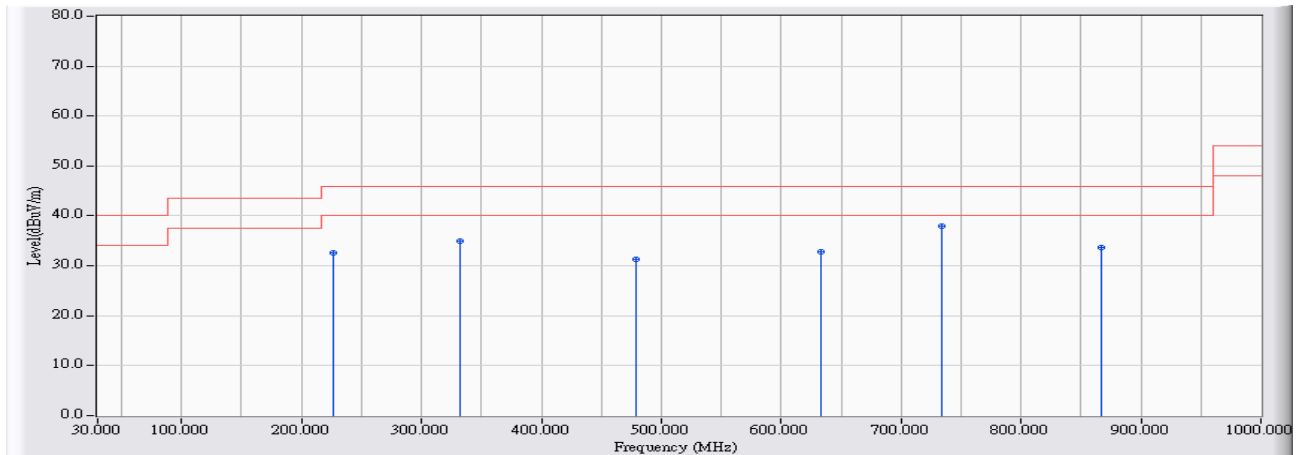

	Frequency (MHz)	Correct Factor (dB)	Reading Level (dBuV)	Measure Level (dBuV/m)	Margin (dB)	Limit (dBuV/m)	Detector Type
1	226.425	-29.174	61.704	32.531	-13.469	46.000	QUASPEAK
2	331.670	-25.493	60.351	34.858	-11.142	46.000	QUASPEAK
3	478.625	-22.535	53.913	31.378	-14.622	46.000	QUASPEAK
4	633.340	-20.890	53.795	32.905	-13.095	46.000	QUASPEAK
5	* 733.250	-20.194	58.107	37.913	-8.087	46.000	QUASPEAK
6	866.625	-18.562	52.336	33.774	-12.226	46.000	QUASPEAK

Note:

1. All Reading Levels are Quasi-Peak value.
2. “ * ”, means this data is the worst emission level.
3. Measurement Level = Reading Level + Correct Factor

Site : CB3	Time : 2014/10/15 - 16:03
Limit : FCC_CLASS_B_03M_QP	Margin : 6
Probe : CB3_FCC_EFS_30-1G-1_0901 - VERTICAL	Power : AC 120V / 60Hz
EUT : SkyCaddie	Note : Mode 2: Transmit (Power by Adapter)_2441MHz

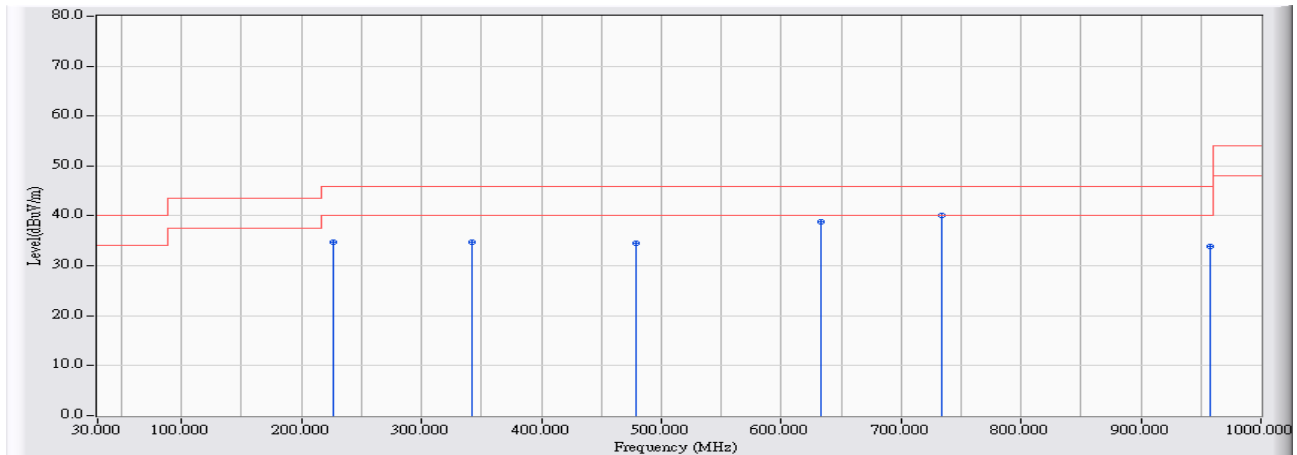

	Frequency (MHz)	Correct Factor (dB)	Reading Level (dBuV)	Measure Level (dBuV/m)	Margin (dB)	Limit (dBuV/m)	Detector Type
1	226.425	-29.174	63.965	34.792	-11.208	46.000	QUASPEAK
2	341.855	-25.220	60.011	34.790	-11.210	46.000	QUASPEAK
3	478.625	-22.535	57.009	34.474	-11.526	46.000	QUASPEAK
4	633.340	-20.890	59.792	38.902	-7.098	46.000	QUASPEAK
5	* 733.250	-20.194	60.242	40.048	-5.952	46.000	QUASPEAK
6	957.320	-17.728	51.718	33.990	-12.010	46.000	QUASPEAK

Note:

1. All Reading Levels are Quasi-Peak value.
2. “ * ”, means this data is the worst emission level.
3. Measurement Level = Reading Level + Correct Factor

Site : CB3	Time : 2014/10/15 - 15:48
Limit : FCC_CLASS_B_03M_QP	Margin : 6
Probe : CB3_FCC_EFS_30-1G-1_0901 - HORIZONTAL	Power : DC 3.7V (Power by Battery)
EUT : SkyCaddie	Note : Mode 3: Transmit (Power by Battery)_2441MHz

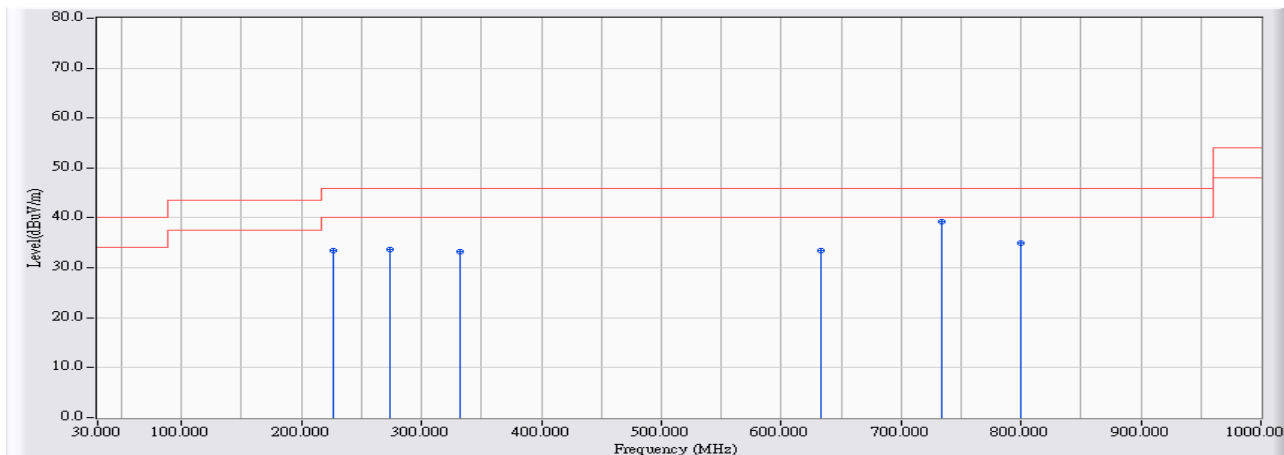

	Frequency (MHz)	Correct Factor (dB)	Reading Level (dBuV)	Measure Level (dBuV/m)	Margin (dB)	Limit (dBuV/m)	Detector Type
1	226.425	-29.174	62.580	33.407	-12.593	46.000	QUASPEAK
2	273.470	-26.869	60.471	33.602	-12.398	46.000	QUASPEAK
3	331.670	-25.493	58.776	33.283	-12.717	46.000	QUASPEAK
4	633.340	-20.890	54.312	33.422	-12.578	46.000	QUASPEAK
5	* 733.250	-20.194	59.490	39.296	-6.704	46.000	QUASPEAK
6	799.695	-18.406	53.443	35.037	-10.963	46.000	QUASPEAK

Note:

1. All Reading Levels are Quasi-Peak value.
2. “ * ”, means this data is the worst emission level.
3. Measurement Level = Reading Level + Correct Factor

Site : CB3	Time : 2014/10/15 - 15:53
Limit : FCC_CLASS_B_03M_QP	Margin : 6
Probe : CB3_FCC_EFS_30-1G-1_0901 - VERTICAL	Power : DC 3.7V (Power by Battery)
EUT : SkyCaddie	Note : Mode 3: Transmit (Power by Battery)_2441MHz

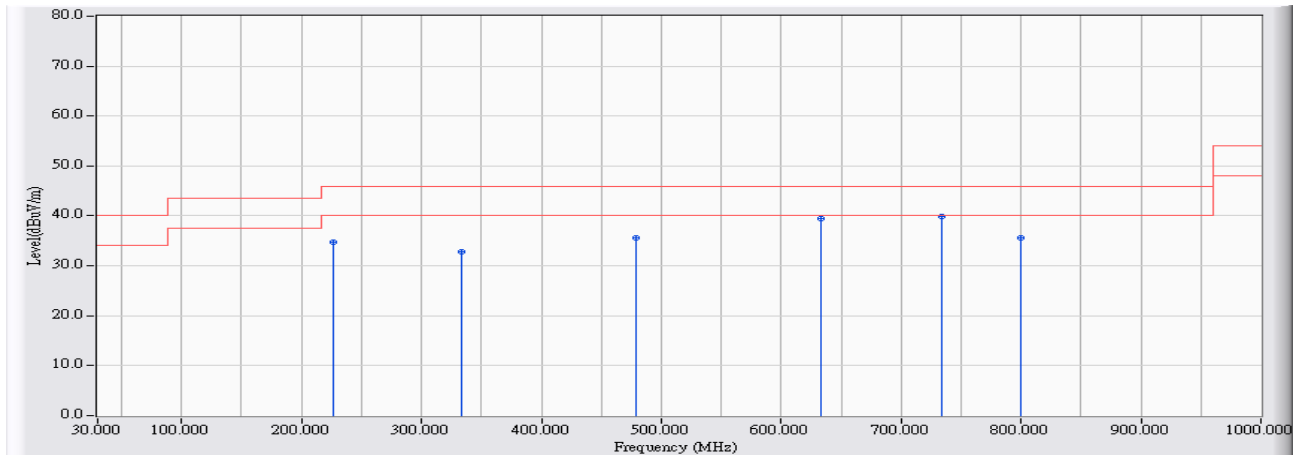

	Frequency (MHz)	Correct Factor (dB)	Reading Level (dBuV)	Measure Level (dBuV/m)	Margin (dB)	Limit (dBuV/m)	Detector Type
1	226.425	-29.174	63.948	34.775	-11.225	46.000	QUASPEAK
2	333.125	-25.453	58.265	32.811	-13.189	46.000	QUASPEAK
3	478.625	-22.535	58.205	35.670	-10.330	46.000	QUASPEAK
4	633.340	-20.890	60.384	39.494	-6.506	46.000	QUASPEAK
5	* 733.250	-20.194	60.018	39.824	-6.176	46.000	QUASPEAK
6	799.695	-18.406	54.116	35.710	-10.290	46.000	QUASPEAK

Note:

1. All Reading Levels are Quasi-Peak value.
2. “ * ”, means this data is the worst emission level.
3. Measurement Level = Reading Level + Correct Factor

Harmonic & Spurious:

Site : CB1	Time : 2014/09/25 - 15:46
Limit : FCC_SpartC_15.247_H_03M_PK	Margin : 6
Probe : CB1_FCC_EFS_1-18G-1_0901 - HORIZONTAL	Power : DC5V(Power by PC)
EUT : SkyCaddie	Note : Mode 1: Transmit (Power by PC)_ $\pi/4$ -DQPSK, 2402MHz

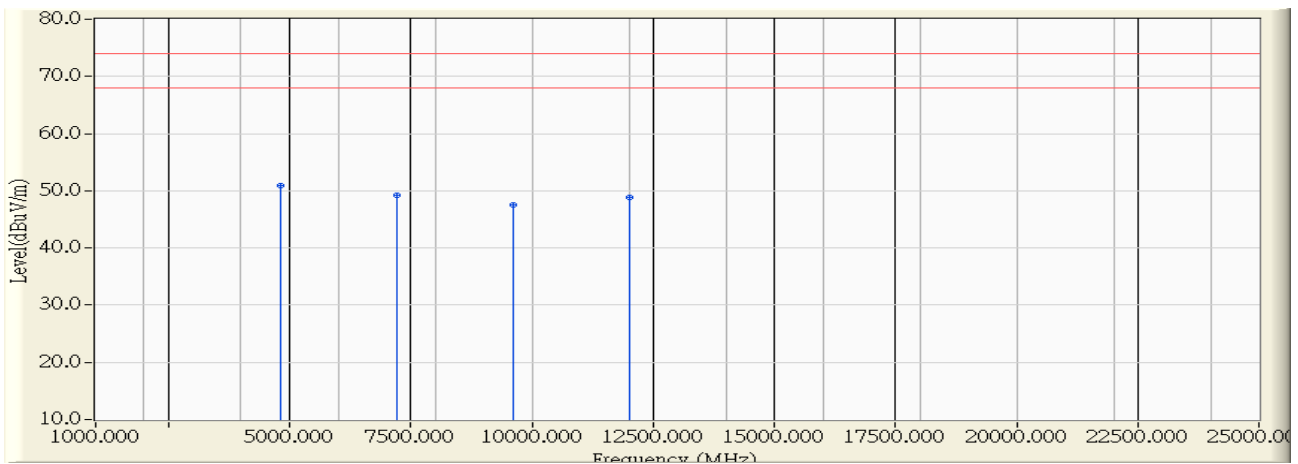

		Frequency (MHz)	Correct Factor (dB)	Reading Level (dBuV)	Measure Level (dBuV/m)	Margin (dB)	Limit (dBuV/m)	Detector Type
1	*	4804.000	-0.582	51.560	50.978	-23.022	74.000	PEAK
2		7206.000	5.454	43.760	49.214	-24.786	74.000	PEAK
3		9608.000	9.187	38.260	47.447	-26.553	74.000	PEAK
4		12010.000	11.122	37.810	48.933	-25.067	74.000	PEAK

Note:

1. All readings above 1GHz are performed with peak and/or average measurements as necessary.
2. Peak measurements: RBW = 1MHz, VBW = 1MHz, Sweep: Auto.
3. Average measurements: RBW = 1MHz, VBW = 10 Hz, Sweep: Auto.
4. “ * ”, means this data is the worst emission level.
5. Measurement Level = Reading Level + Correct Factor.
6. The average measurement was not performed when the peak measured data under the limit of average detection.
7. The Emission above 13GHz were not included is because their levels are too low.

Site : CB1	Time : 2014/09/25 - 15:54
Limit : FCC_SpartC_15.247_H_03M_PK	Margin : 6
Probe : CB1_FCC_EFS_1-18G-1_0901 - VERTICAL	Power : DC5V(Power by PC)
EUT : SkyCaddie	Note : Mode 1: Transmit (Power by PC)_ π/4-DQPSK,2402MHz

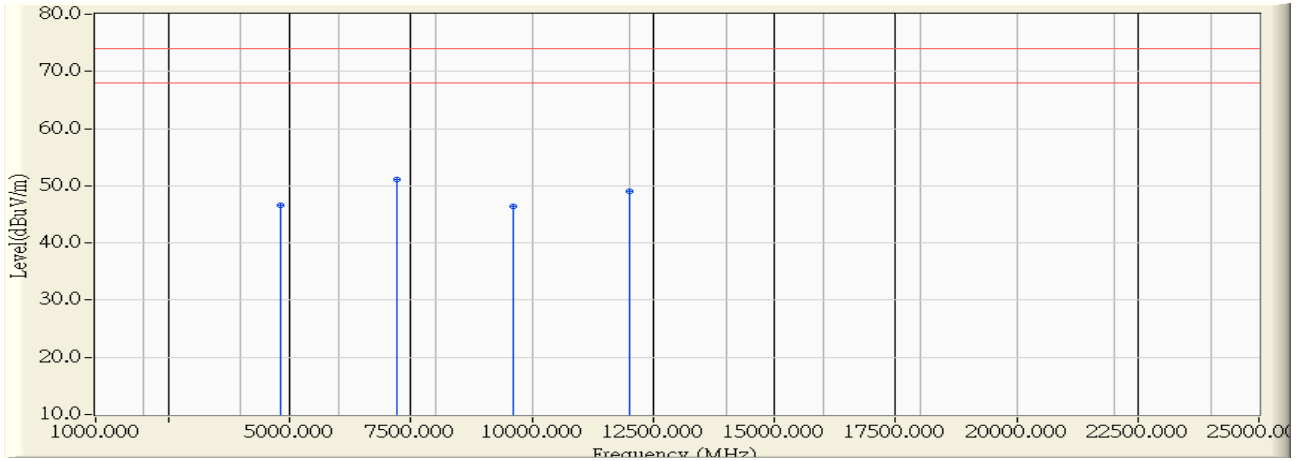

	Frequency (MHz)	Correct Factor (dB)	Reading Level (dBuV)	Measure Level (dBuV/m)	Margin (dB)	Limit (dBuV/m)	Detector Type
1	4804.000	-0.582	47.130	46.548	-27.452	74.000	PEAK
2	* 7206.000	5.454	45.620	51.074	-22.926	74.000	PEAK
3	9608.000	9.187	37.160	46.347	-27.653	74.000	PEAK
4	12010.000	11.122	37.840	48.963	-25.037	74.000	PEAK

Note:

1. All readings above 1GHz are performed with peak and/or average measurements as necessary.
2. Peak measurements: RBW = 1MHz, VBW = 1MHz, Sweep: Auto.
3. Average measurements: RBW = 1MHz, VBW = 10 Hz, Sweep: Auto.
4. “ * ”, means this data is the worst emission level.
5. Measurement Level = Reading Level + Correct Factor.
6. The average measurement was not performed when the peak measured data under the limit of average detection.
7. The Emission above 13GHz were not included is because their levels are too low.

Site : CB1	Time : 2014/10/07 - 03:13
Limit : FCC_SpartC_15.247_H_03M_PK	Margin : 6
Probe : CB1_FCC_EFS_1-18G-1_0901 - HORIZONTAL	Power : AC 120V / 60Hz
EUT : SkyCaddie	Note : Mode 1: Transmit (Power by PC)_ π/4-DQPSK,2441MHz

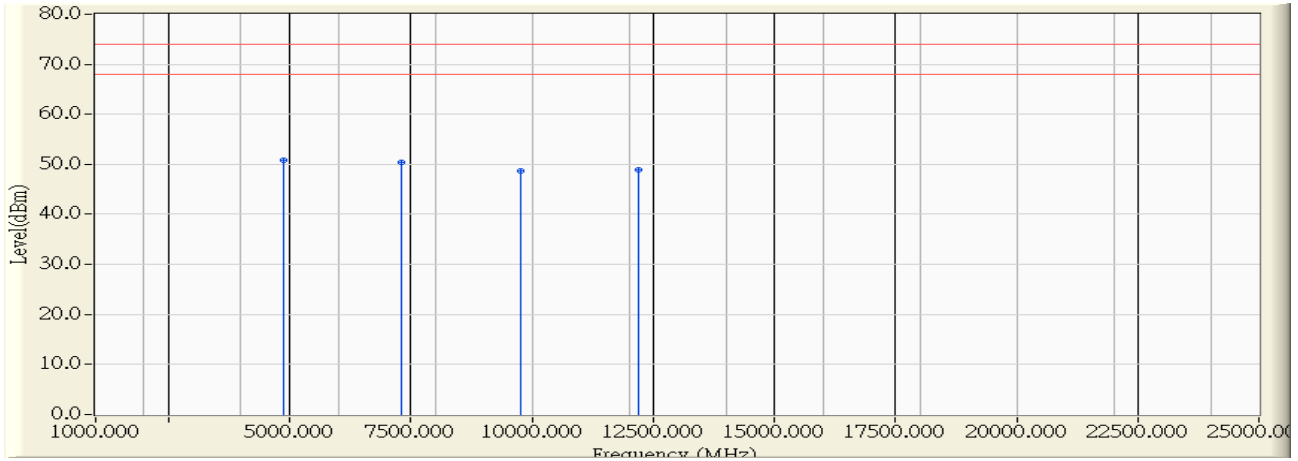

		Frequency (MHz)	Correct Factor (dB)	Reading Level (dBm)	Measure Level (dBm)	Margin (dB)	Limit (dBm)	Detector Type
1	*	4882.000	-0.392	51.280	50.888	-23.112	74.000	PEAK
2		7323.000	5.707	44.730	50.437	-23.563	74.000	PEAK
3		9764.000	10.197	38.480	48.677	-25.323	74.000	PEAK
4		12205.000	11.033	37.960	48.994	-25.006	74.000	PEAK

Note:

1. All readings above 1GHz are performed with peak and/or average measurements as necessary.
2. Peak measurements: RBW = 1MHz, VBW = 1MHz, Sweep: Auto.
3. Average measurements: RBW = 1MHz, VBW = 10 Hz, Sweep: Auto.
4. “ * ”, means this data is the worst emission level.
5. Measurement Level = Reading Level + Correct Factor.
6. The average measurement was not performed when the peak measured data under the limit of average detection.
7. The Emission above 13GHz were not included is because their levels are too low.

Site : CB1	Time : 2014/10/07 - 03:16
Limit : FCC_SpartC_15.247_H_03M_PK	Margin : 6
Probe : CB1_FCC_EFS_1-18G-1_0901 - VERTICAL	Power : AC 120V / 60Hz
EUT : SkyCaddie	Note : Mode 1: Transmit (Power by PC)_ $\pi/4$ -DQPSK, 2441MHz

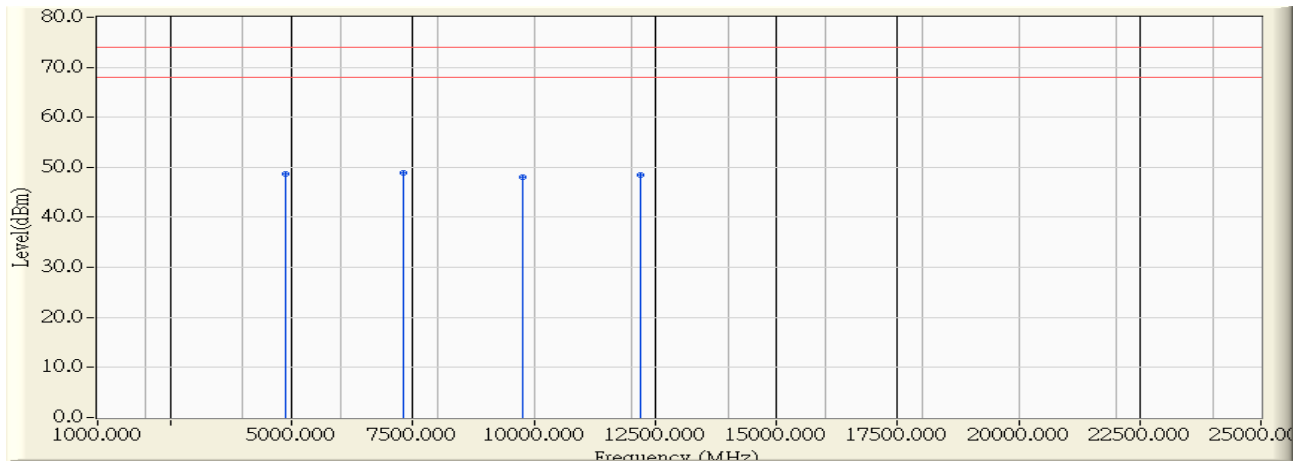

	Frequency (MHz)	Correct Factor (dB)	Reading Level (dBm)	Measure Level (dBm)	Margin (dB)	Limit (dBm)	Detector Type
1	4882.000	-0.392	48.990	48.598	-25.402	74.000	PEAK
2	* 7323.000	5.707	43.200	48.907	-25.093	74.000	PEAK
3	9764.000	10.197	37.940	48.137	-25.863	74.000	PEAK
4	12205.000	11.033	37.360	48.394	-25.606	74.000	PEAK

Note:

1. All readings above 1GHz are performed with peak and/or average measurements as necessary.
2. Peak measurements: RBW = 1MHz, VBW = 1MHz, Sweep: Auto.
3. Average measurements: RBW = 1MHz, VBW = 10 Hz, Sweep: Auto.
4. “ * ”, means this data is the worst emission level.
5. Measurement Level = Reading Level + Correct Factor.
6. The average measurement was not performed when the peak measured data under the limit of average detection.
7. The Emission above 13GHz were not included is because their levels are too low.

Site : CB1	Time : 2014/09/25 - 15:59
Limit : FCC_SpartC_15.247_H_03M_PK	Margin : 6
Probe : CB1_FCC_EFS_1-18G-1_0901 - HORIZONTAL	Power : AC 120V / 60Hz
EUT : SkyCaddie	Note : Mode 1: Transmit (Power by PC)_ $\pi/4$ -DQPSK, 2480MHz

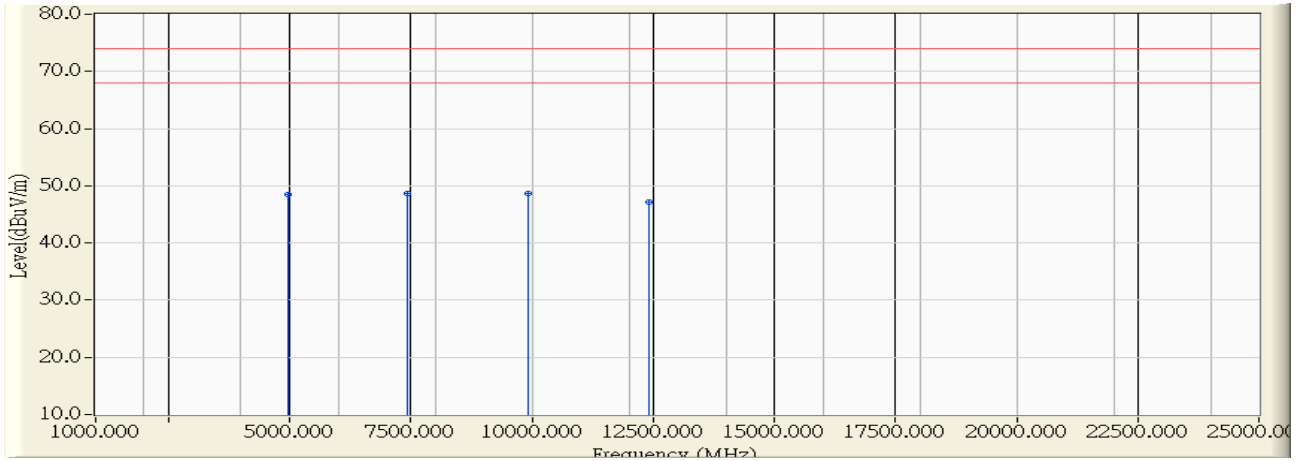

	Frequency (MHz)	Correct Factor (dB)	Reading Level (dBuV)	Measure Level (dBuV/m)	Margin (dB)	Limit (dBuV/m)	Detector Type
1	4960.000	-0.202	48.590	48.388	-25.612	74.000	PEAK
2	7440.000	5.960	42.670	48.630	-25.370	74.000	PEAK
3	* 9920.000	11.207	37.460	48.667	-25.333	74.000	PEAK
4	12400.000	10.944	36.240	47.185	-26.815	74.000	PEAK

Note:

1. All readings above 1GHz are performed with peak and/or average measurements as necessary.
2. Peak measurements: RBW = 1MHz, VBW = 1MHz, Sweep: Auto.
3. Average measurements: RBW = 1MHz, VBW = 10 Hz, Sweep: Auto.
4. “ * ”, means this data is the worst emission level.
5. Measurement Level = Reading Level + Correct Factor.
6. The average measurement was not performed when the peak measured data under the limit of average detection.
7. The Emission above 13GHz were not included is because their levels are too low.

Site : CB1	Time : 2014/09/25 - 16:04
Limit : FCC_SpartC_15.247_H_03M_PK	Margin : 6
Probe : CB1_FCC_EFS_1-18G-1_0901 - VERTICAL	Power : AC 120V / 60Hz
EUT : SkyCaddie	Note : Mode 1: Transmit (Power by PC)_ $\pi/4$ -DQPSK, 2480MHz

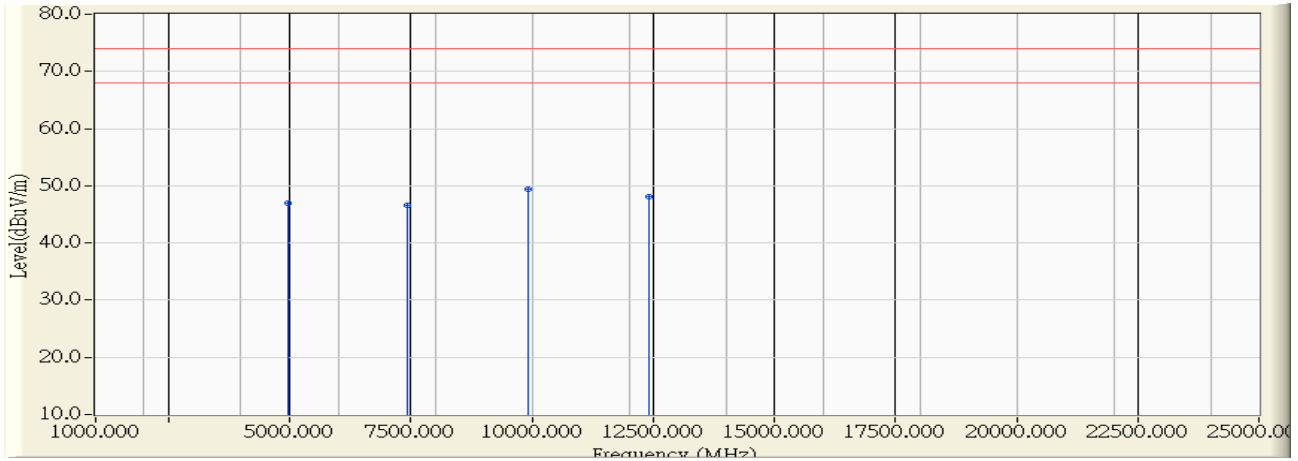

	Frequency (MHz)	Correct Factor (dB)	Reading Level (dBuV)	Measure Level (dBuV/m)	Margin (dB)	Limit (dBuV/m)	Detector Type
1	4960.000	-0.202	47.170	46.968	-27.032	74.000	PEAK
2	7440.000	5.960	40.650	46.610	-27.390	74.000	PEAK
3	* 9920.000	11.207	38.110	49.317	-24.683	74.000	PEAK
4	12400.000	10.944	37.180	48.125	-25.875	74.000	PEAK

Note:

1. All readings above 1GHz are performed with peak and/or average measurements as necessary.
2. Peak measurements: RBW = 1MHz, VBW = 1MHz, Sweep: Auto.
3. Average measurements: RBW = 1MHz, VBW = 10 Hz, Sweep: Auto.
4. “ * ”, means this data is the worst emission level.
5. Measurement Level = Reading Level + Correct Factor.
6. The average measurement was not performed when the peak measured data under the limit of average detection.
7. The Emission above 13GHz were not included is because their levels are too low.

Site : CB1	Time : 2014/09/25 - 16:08
Limit : FCC_SpartC_15.247_H_03M_PK	Margin : 6
Probe : CB1_FCC_EFS_1-18G-1_0901 - HORIZONTAL	Power : AC 120V / 60Hz
EUT : SkyCaddie	Note : Mode 1: Transmit (Power by PC)_ 8-DQPSK,2402MHz

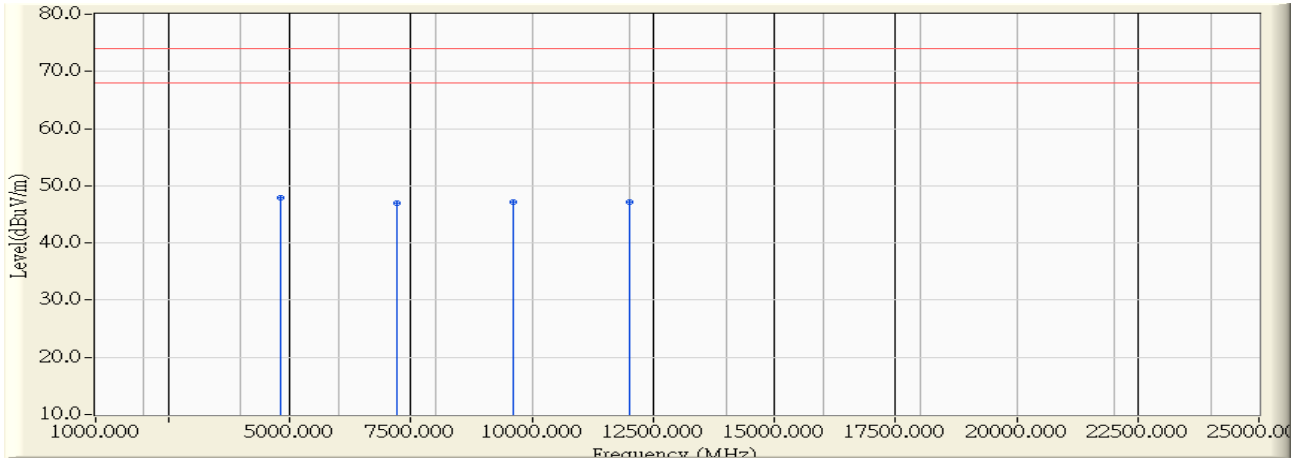

		Frequency (MHz)	Correct Factor (dB)	Reading Level (dBuV)	Measure Level (dBuV/m)	Margin (dB)	Limit (dBuV/m)	Detector Type
1	*	4804.000	-0.582	48.540	47.958	-26.042	74.000	PEAK
2		7206.000	5.454	41.500	46.954	-27.046	74.000	PEAK
3		9608.000	9.187	37.930	47.117	-26.883	74.000	PEAK
4		12010.000	11.122	36.010	47.133	-26.867	74.000	PEAK

Note:

1. All readings above 1GHz are performed with peak and/or average measurements as necessary.
2. Peak measurements: RBW = 1MHz, VBW = 1MHz, Sweep: Auto.
3. Average measurements: RBW = 1MHz, VBW = 10 Hz, Sweep: Auto.
4. “ * ”, means this data is the worst emission level.
5. Measurement Level = Reading Level + Correct Factor.
6. The average measurement was not performed when the peak measured data under the limit of average detection.
7. The Emission above 13GHz were not included is because their levels are too low.

Site : CB1	Time : 2014/09/25 - 16:12
Limit : FCC_SpartC_15.247_H_03M_PK	Margin : 6
Probe : CB1_FCC_EFS_1-18G-1_0901 - VERTICAL	Power : AC 120V / 60Hz
EUT : SkyCaddie	Note : Mode 1: Transmit (Power by PC)_ 8-DQPSK, 2402MHz

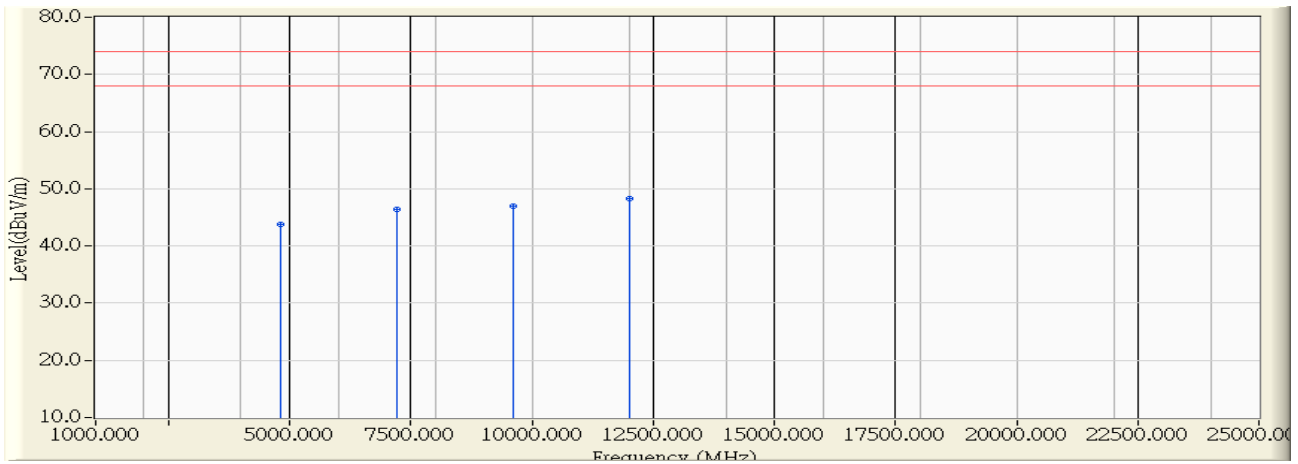

	Frequency (MHz)	Correct Factor (dB)	Reading Level (dBuV)	Measure Level (dBuV/m)	Margin (dB)	Limit (dBuV/m)	Detector Type
1	4804.000	-0.582	44.270	43.688	-30.312	74.000	PEAK
2	7206.000	5.454	40.940	46.394	-27.606	74.000	PEAK
3	9608.000	9.187	37.820	47.007	-26.993	74.000	PEAK
4	* 12010.000	11.122	37.070	48.193	-25.807	74.000	PEAK

Note:

1. All readings above 1GHz are performed with peak and/or average measurements as necessary.
2. Peak measurements: RBW = 1MHz, VBW = 1MHz, Sweep: Auto.
3. Average measurements: RBW = 1MHz, VBW = 10 Hz, Sweep: Auto.
4. “ * ”, means this data is the worst emission level.
5. Measurement Level = Reading Level + Correct Factor.
6. The average measurement was not performed when the peak measured data under the limit of average detection.
7. The Emission above 13GHz were not included is because their levels are too low.

Site : CB1	Time : 2014/10/07 - 03:24
Limit : FCC_SpartC_15.247_H_03M_PK	Margin : 6
Probe : CB1_FCC_EFS_1-18G-1_0901 - HORIZONTAL	Power : AC 120V / 60Hz
EUT : SkyCaddie	Note : Mode 1: Transmit (Power by PC)_ 8-DQPSK, 2441MHz

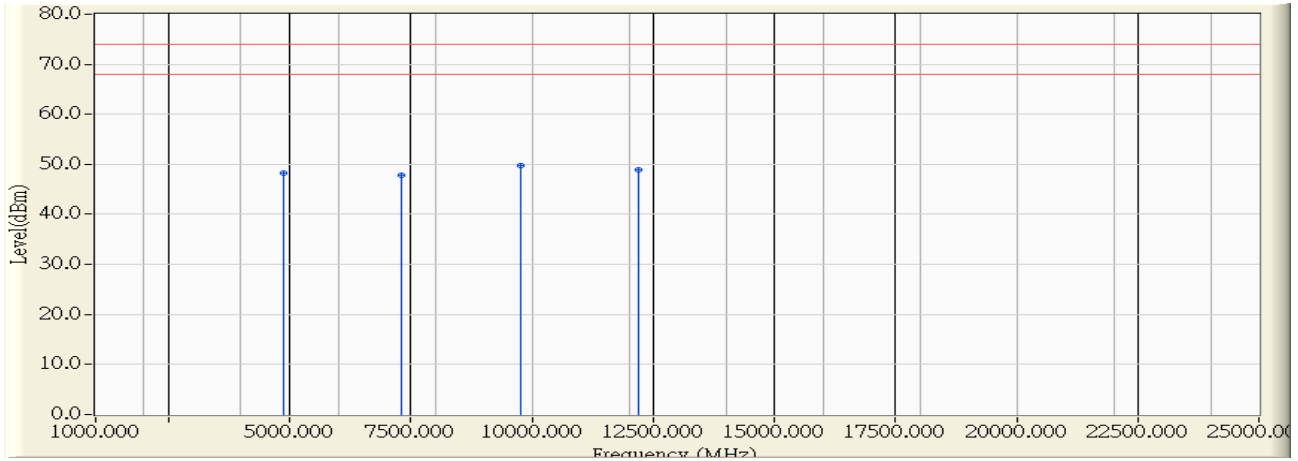

	Frequency (MHz)	Correct Factor (dB)	Reading Level (dBm)	Measure Level (dBm)	Margin (dB)	Limit (dBm)	Detector Type
1	4882.000	-0.392	48.590	48.198	-25.802	74.000	PEAK
2	7322.000	5.705	42.130	47.835	-26.165	74.000	PEAK
3	* 9763.000	10.191	39.560	49.751	-24.249	74.000	PEAK
4	12204.000	11.034	37.800	48.834	-25.166	74.000	PEAK

Note:

1. All readings above 1GHz are performed with peak and/or average measurements as necessary.
2. Peak measurements: RBW = 1MHz, VBW = 1MHz, Sweep: Auto.
3. Average measurements: RBW = 1MHz, VBW = 10 Hz, Sweep: Auto.
4. “ * ”, means this data is the worst emission level.
5. Measurement Level = Reading Level + Correct Factor.
6. The average measurement was not performed when the peak measured data under the limit of average detection.
7. The Emission above 13GHz were not included is because their levels are too low.

Site : CB1	Time : 2014/10/07 - 03:21
Limit : FCC_SpartC_15.247_H_03M_PK	Margin : 6
Probe : CB1_FCC_EFS_1-18G-1_0901 - VERTICAL	Power : AC 120V / 60Hz
EUT : SkyCaddie	Note : Mode 1: Transmit (Power by PC)_ 8-DQPSK,2441MHz

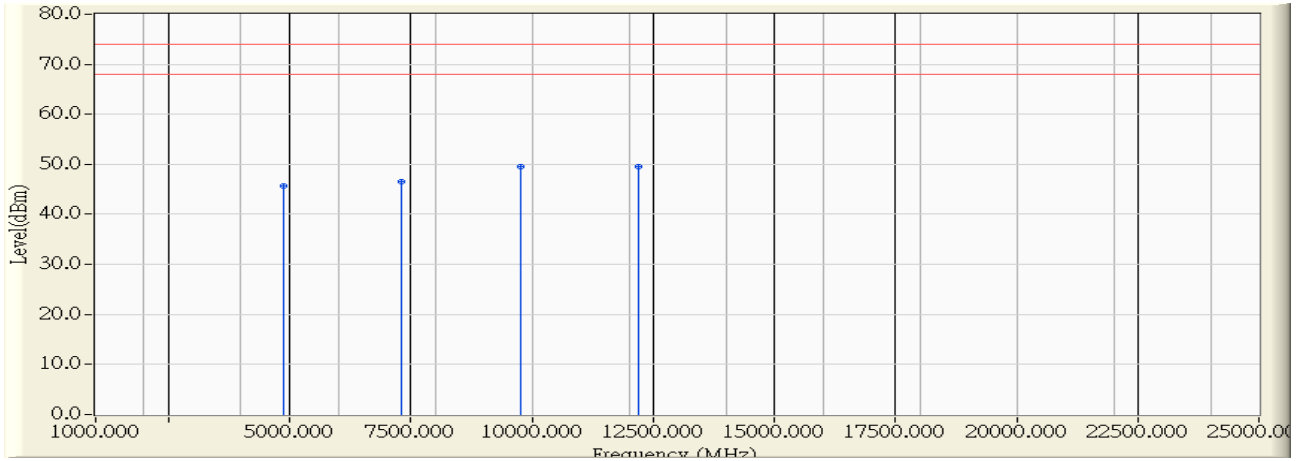

	Frequency (MHz)	Correct Factor (dB)	Reading Level (dBm)	Measure Level (dBm)	Margin (dB)	Limit (dBm)	Detector Type
1	4882.000	-0.392	46.150	45.758	-28.242	74.000	PEAK
2	7323.000	5.707	40.770	46.477	-27.523	74.000	PEAK
3	9764.000	10.197	39.340	49.537	-24.463	74.000	PEAK
4	* 12204.000	11.034	38.550	49.584	-24.416	74.000	PEAK

Note:

1. All readings above 1GHz are performed with peak and/or average measurements as necessary.
2. Peak measurements: RBW = 1MHz, VBW = 1MHz, Sweep: Auto.
3. Average measurements: RBW = 1MHz, VBW = 10 Hz, Sweep: Auto.
4. “ * ”, means this data is the worst emission level.
5. Measurement Level = Reading Level + Correct Factor.
6. The average measurement was not performed when the peak measured data under the limit of average detection.
7. The Emission above 13GHz were not included is because their levels are too low.

Site : CB1	Time : 2014/09/25 - 16:16
Limit : FCC_SpartC_15.247_H_03M_PK	Margin : 6
Probe : CB1_FCC_EFS_1-18G-1_0901 - HORIZONTAL	Power : AC 120V / 60Hz
EUT : SkyCaddie	Note : Mode 1: Transmit (Power by PC)_ 8-DQPSK, 2480MHz

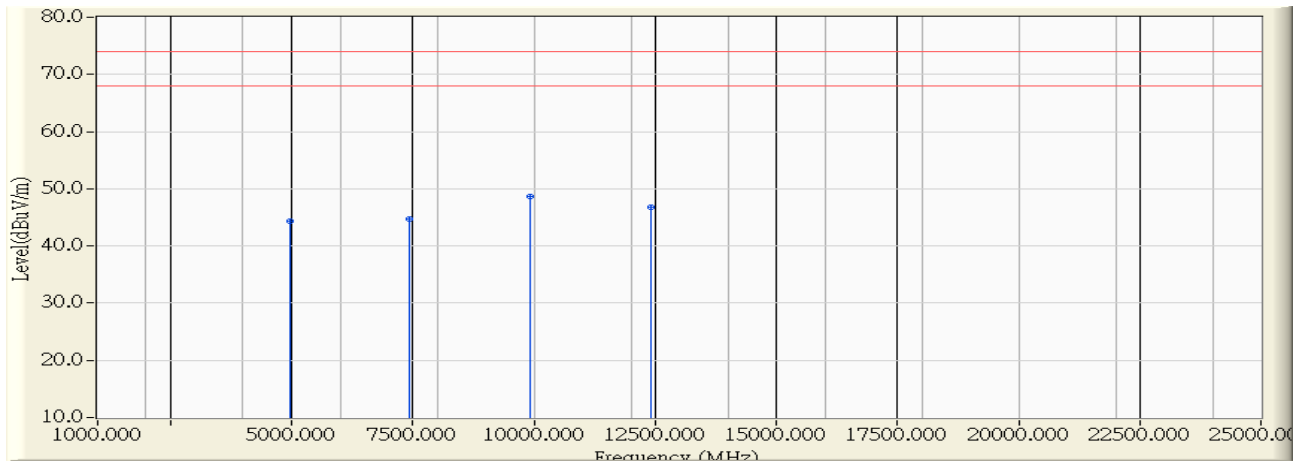

	Frequency (MHz)	Correct Factor (dB)	Reading Level (dBuV)	Measure Level (dBuV/m)	Margin (dB)	Limit (dBuV/m)	Detector Type
1	4960.000	-0.202	44.550	44.348	-29.652	74.000	PEAK
2	7440.000	5.960	38.750	44.710	-29.290	74.000	PEAK
3	* 9920.000	11.207	37.500	48.707	-25.293	74.000	PEAK
4	12400.000	10.944	35.750	46.695	-27.305	74.000	PEAK

Note:

1. All readings above 1GHz are performed with peak and/or average measurements as necessary.
2. Peak measurements: RBW = 1MHz, VBW = 1MHz, Sweep: Auto.
3. Average measurements: RBW = 1MHz, VBW = 10 Hz, Sweep: Auto.
4. “ * ”, means this data is the worst emission level.
5. Measurement Level = Reading Level + Correct Factor.
6. The average measurement was not performed when the peak measured data under the limit of average detection.
7. The Emission above 13GHz were not included is because their levels are too low.

Site : CB1	Time : 2014/09/25 - 16:20
Limit : FCC_SpartC_15.247_H_03M_PK	Margin : 6
Probe : CB1_FCC_EFS_1-18G-1_0901 - VERTICAL	Power : AC 120V / 60Hz
EUT : SkyCaddie	Note : Mode 1: Transmit (Power by PC)_ 8-DQPSK, 2480MHz

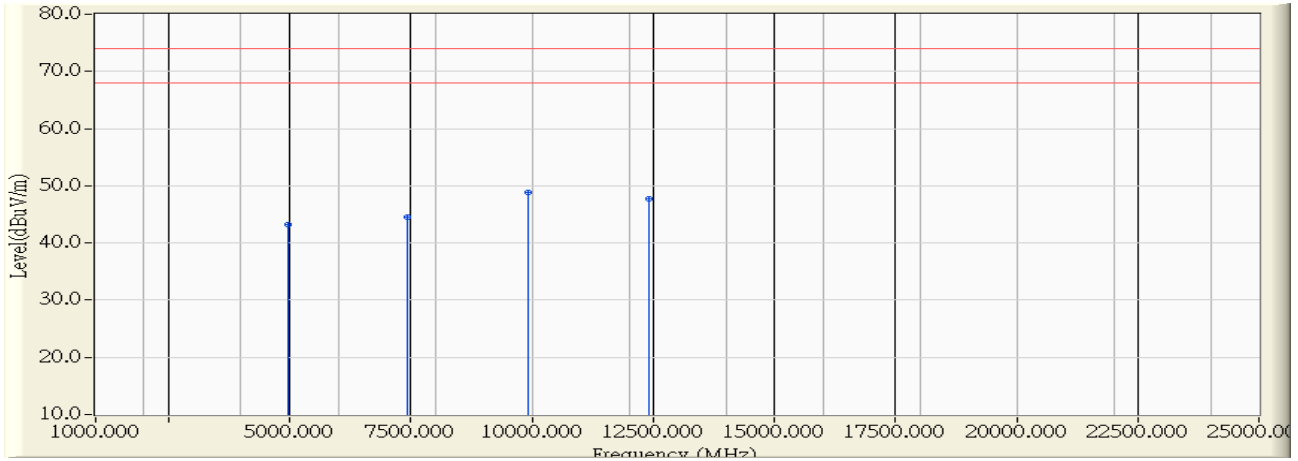

	Frequency (MHz)	Correct Factor (dB)	Reading Level (dBuV)	Measure Level (dBuV/m)	Margin (dB)	Limit (dBuV/m)	Detector Type
1	4960.000	-0.202	43.430	43.228	-30.772	74.000	PEAK
2	7440.000	5.960	38.520	44.480	-29.520	74.000	PEAK
3	* 9920.000	11.207	37.660	48.867	-25.133	74.000	PEAK
4	12400.000	10.944	36.700	47.645	-26.355	74.000	PEAK

Note:

1. All readings above 1GHz are performed with peak and/or average measurements as necessary.
2. Peak measurements: RBW = 1MHz, VBW = 1MHz, Sweep: Auto.
3. Average measurements: RBW = 1MHz, VBW = 10 Hz, Sweep: Auto.
4. “ * ”, means this data is the worst emission level.
5. Measurement Level = Reading Level + Correct Factor.
6. The average measurement was not performed when the peak measured data under the limit of average detection.
7. The Emission above 13GHz were not included is because their levels are too low.

5. RF antenna conducted test

5.1. Test Equipment

The following test equipment is used during the test:

RF antenna conducted test / SR7

Instrument	Manufacturer	Model No.	Serial No	Next Cal. Date
Spectrum Analyzer	Agilent	N9010A-EXA	US47140172	2015/07/14

Note: 1. All equipments that need to calibrate are with calibration period of 1 year.

5.2. Test Setup

RF Conducted Measurement:

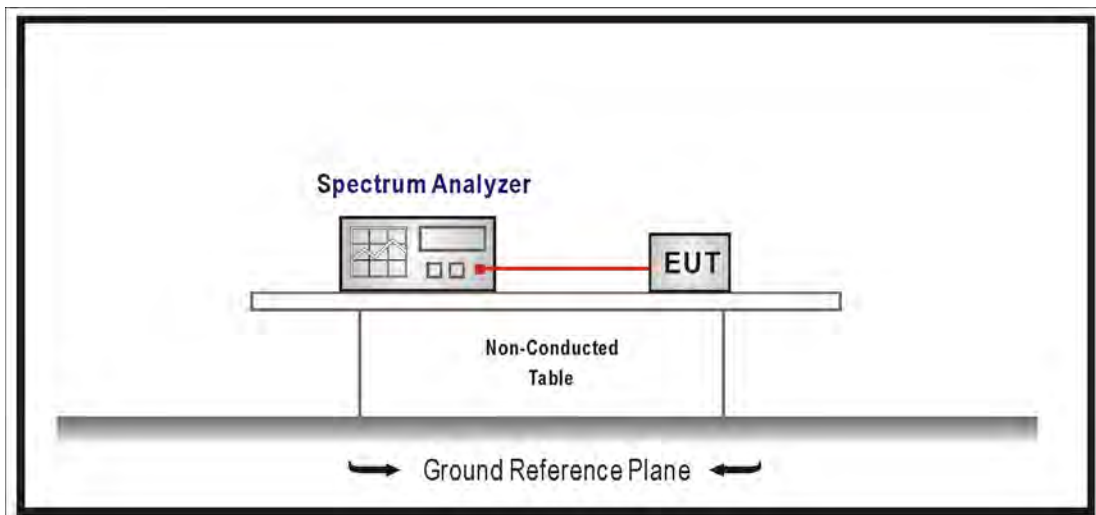

5.3. Limits

In any 100 kHz bandwidth outside the frequency band in which the spread spectrum intentional radiator is operating, the radio frequency power that is produced by the intentional radiator shall be at least 20 dB below that in the 100 kHz bandwidth within the band that contains the highest level of the desired power, based on an RF conducted or radiated measurement. Attenuation below the general limits specified in Section 15.209(a) is not required. In addition, radiated emissions which fall in the restricted bands, as defined in Section 15.205(a), must also comply with the radiated emission limits specified in Section 15.209(a) (see Section 15.205(c)).

5.4. Test Procedure

The EUT was setup according to ANSI C63.10 and tested according to FHSS test procedure of FCC Public Notice DA 00-705 for compliance to FCC 47CFR 15.247 requirements Set RBW = 100 kHz, Set VBW > RBW, scan up through 10th harmonic.

5.5. Test Specification

According to FCC Part 15 Subpart C Paragraph 15.247: 2013

5.6. Test Result

Product	SkyCaddie		
Test Item	RF antenna conducted test		
Test Mode	Mode 1: Transmit (Power by PC)		
Date of Test	2014/02/17	Test Site	SR7

$\pi/4$ -DQPSK

Channel No.	Frequency (MHz)	Measurement Level (dB)	Required Limit (dBc)	Result
00	2402	34.565	≥ 20	Pass

Channel 00

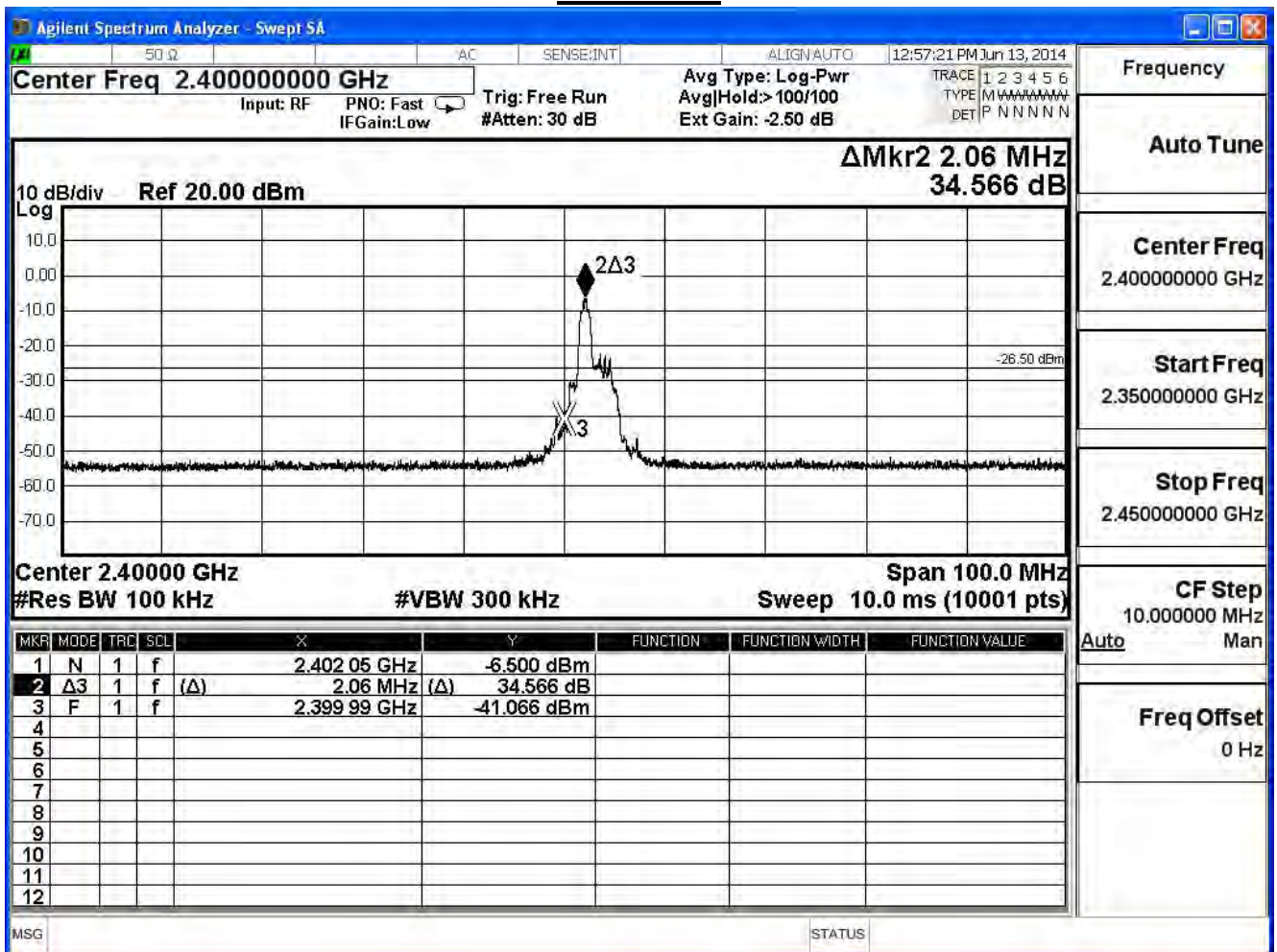

Product	SkyCaddie		
Test Item	RF antenna conducted test		
Test Mode	Mode 1: Transmit (Power by PC)		
Date of Test	2014/02/17	Test Site	SR7

$\pi/4$ -DQPSK

Channel No.	Frequency (MHz)	Measurement Level (dB)	Required Limit (dBc)	Result
39	2441	49.725	≥ 20	Pass

Channel 39

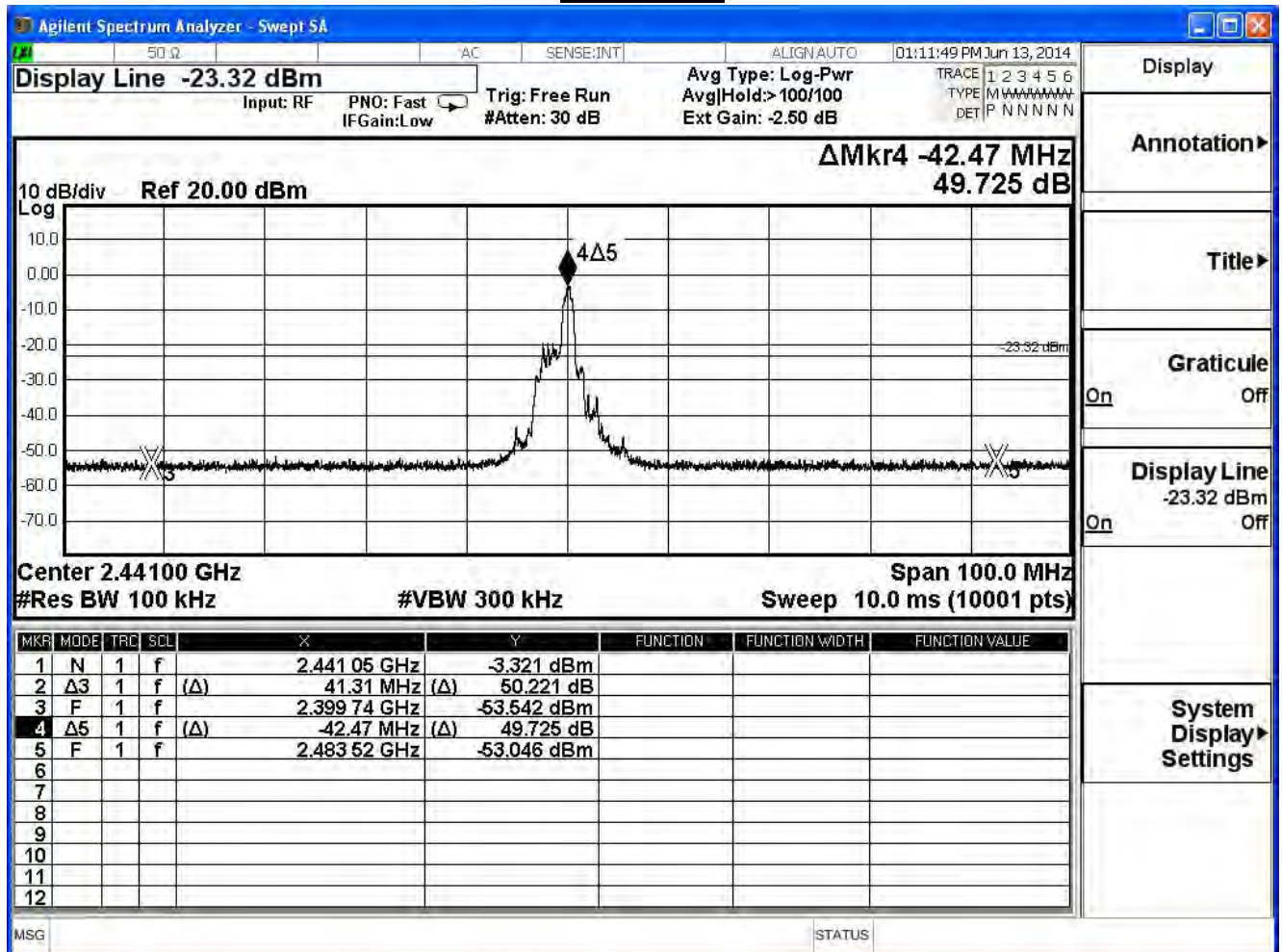

Product	SkyCaddie		
Test Item	RF antenna conducted test		
Test Mode	Mode 1: Transmit (Power by PC)		
Date of Test	2014/02/17	Test Site	SR7

$\pi/4$ -DQPSK

Channel No.	Frequency (MHz)	Measurement Level (dB)	Required Limit (dBc)	Result
78	2480	42.394	≥ 20	Pass

Channel 78

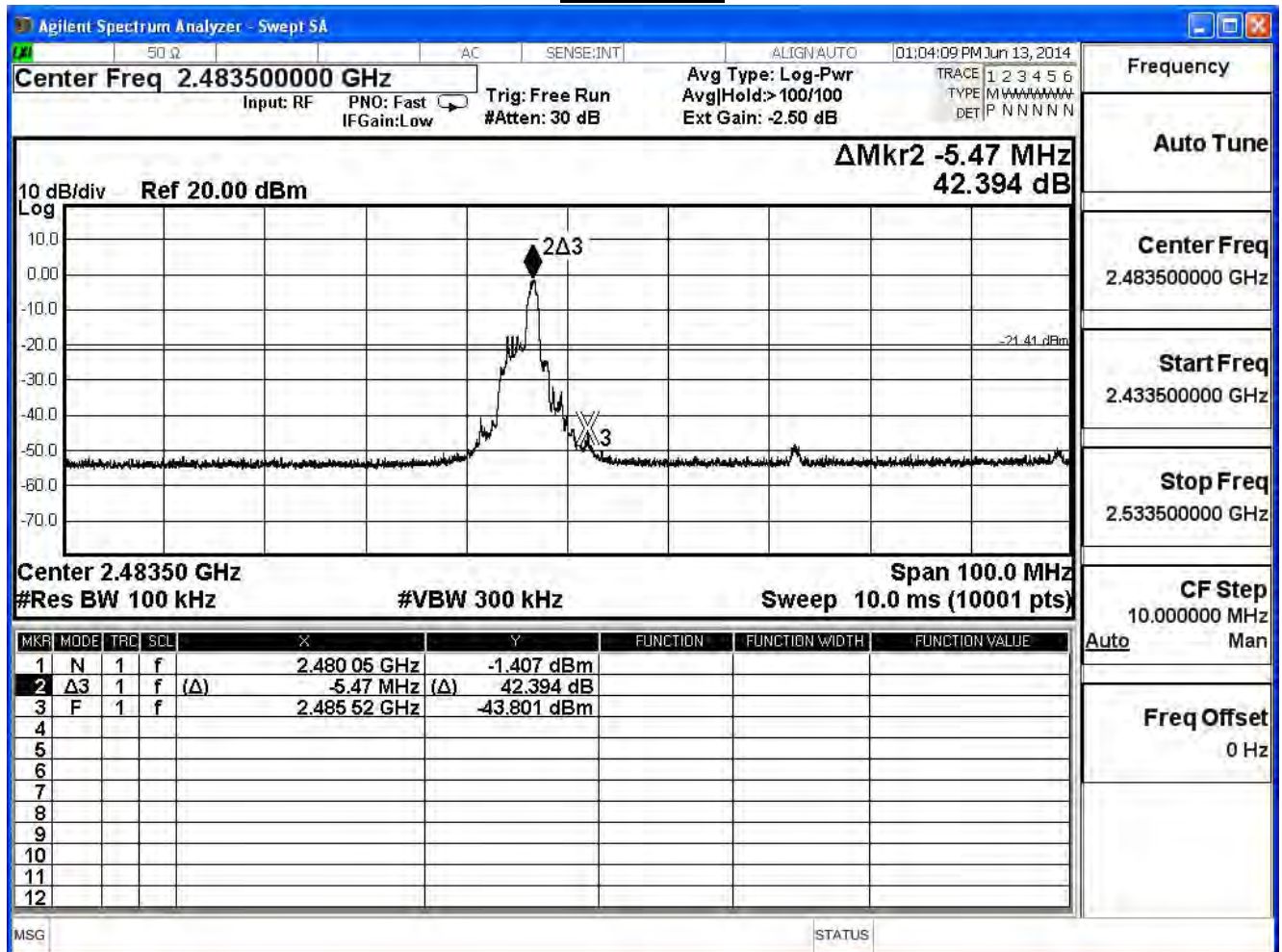

Product	SkyCaddie		
Test Item	RF antenna conducted test		
Test Mode	Mode 1: Transmit (Power by PC)		
Date of Test	2014/02/17	Test Site	SR7

8-DQPSK

Channel No.	Frequency (MHz)	Measurement Level (dB)	Required Limit (dBc)	Result
00	2402	32.792	≥ 20	Pass

Channel 00

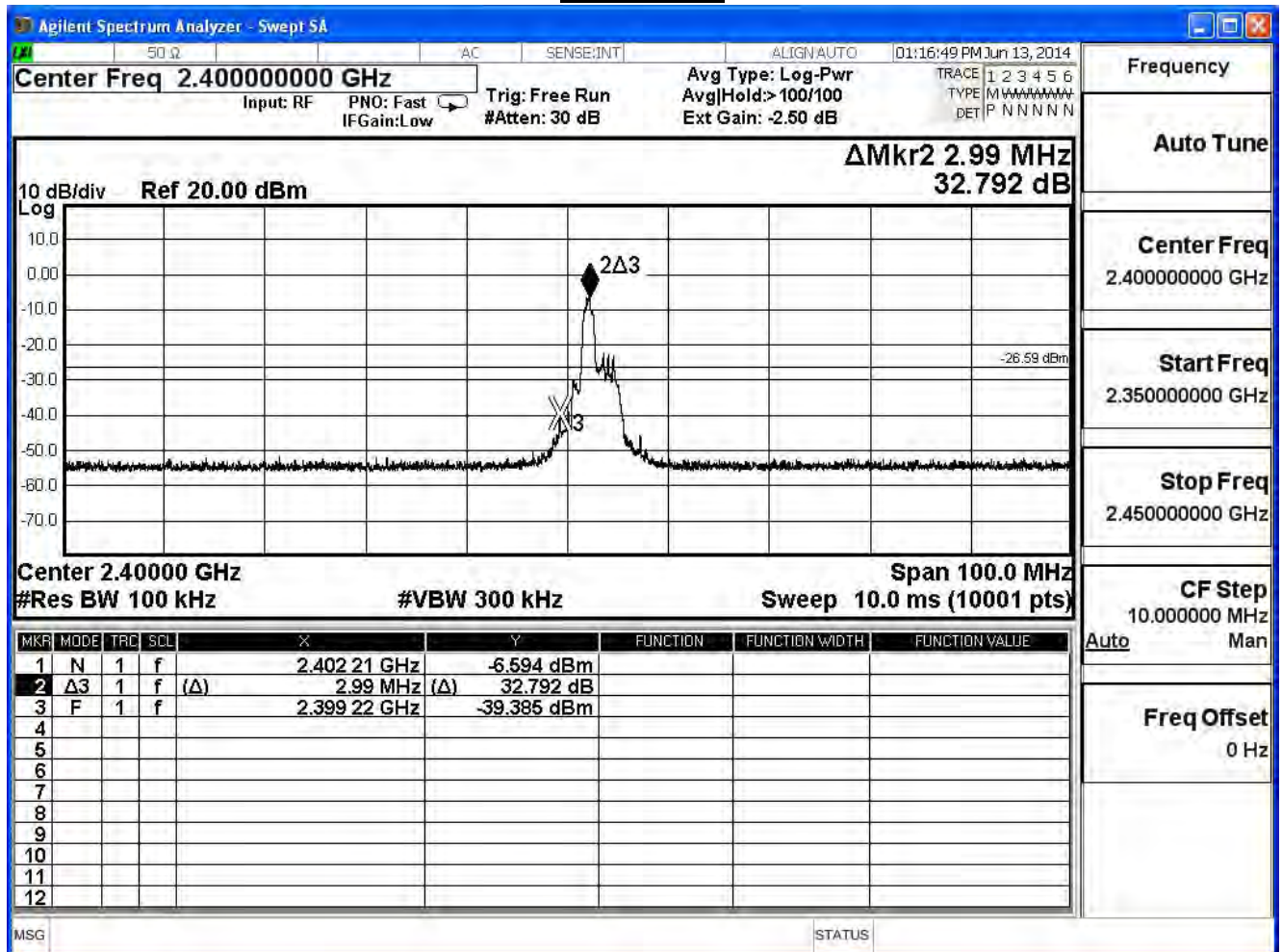

Product	SkyCaddie		
Test Item	RF antenna conducted test		
Test Mode	Mode 1: Transmit (Power by PC)		
Date of Test	2014/02/17	Test Site	SR7

8-DQPSK

Channel No.	Frequency (MHz)	Measurement Level (dB)	Required Limit (dBc)	Result
39	2441	48.929	≥ 20	Pass

Channel 39

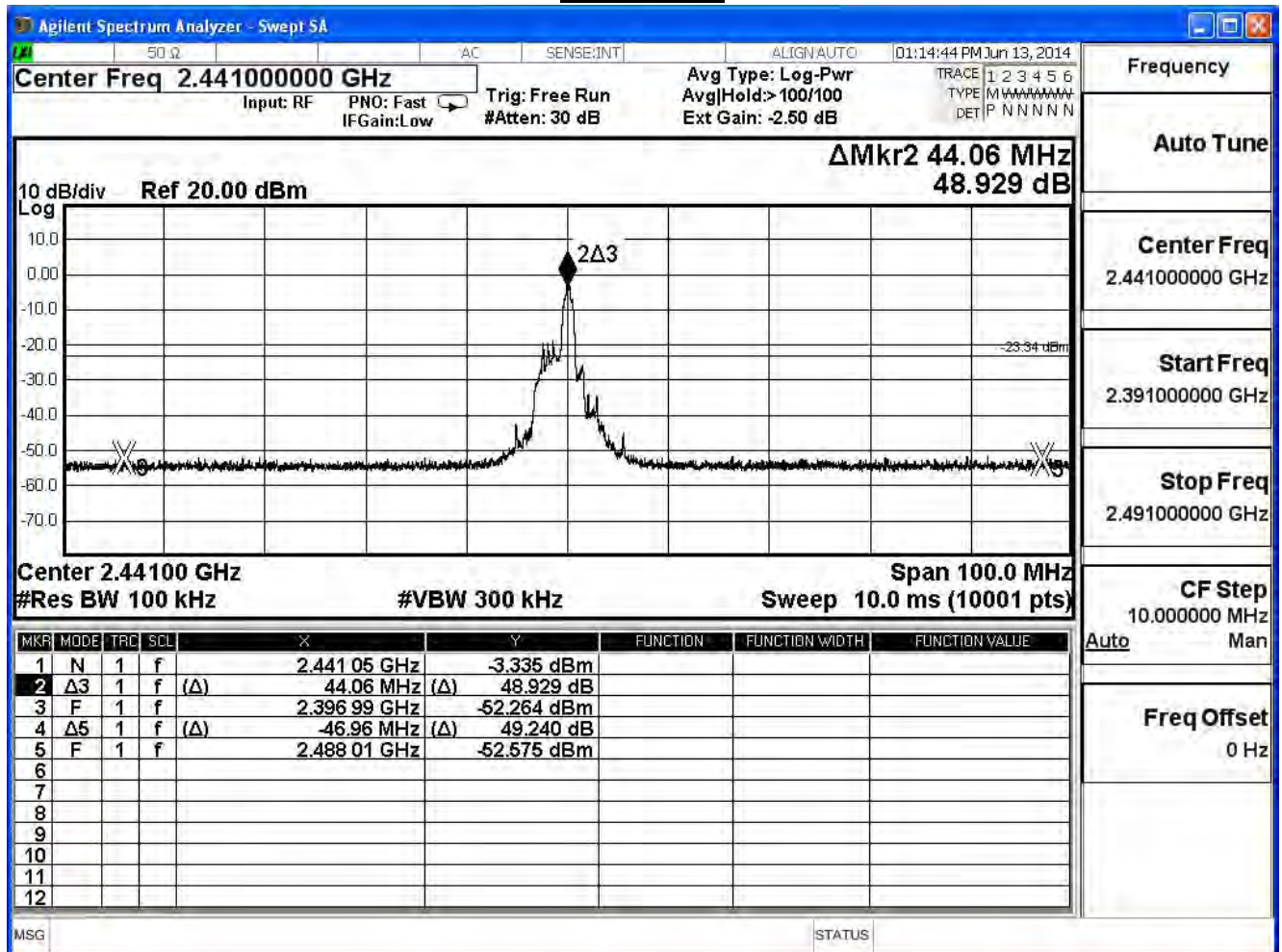

Product	SkyCaddie		
Test Item	RF antenna conducted test		
Test Mode	Mode 1: Transmit (Power by PC)		
Date of Test	2014/02/17	Test Site	SR7

8-DQPSK

Channel No.	Frequency (MHz)	Measurement Level (dB)	Required Limit (dBc)	Result
78	2480	39.531	≥ 20	Pass

Channel 78

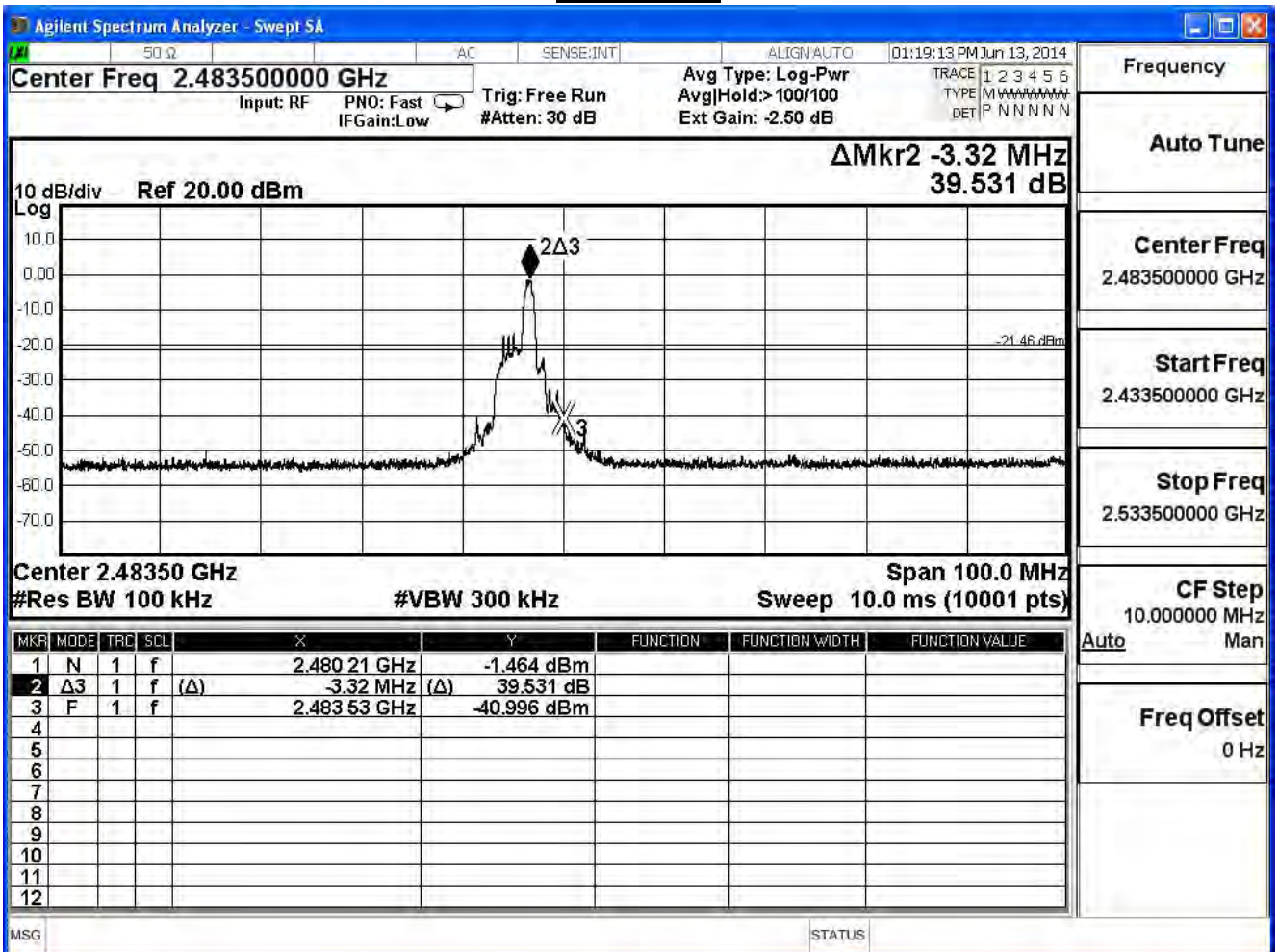

Product	SkyCaddie		
Test Item	RF antenna conducted test		
Test Mode	Mode 1: Transmit (Power by PC)		
Date of Test	2014/02/17	Test Site	SR7

Channel 00 (30MHz-1GHz)- $\pi/4$ -DQPSK

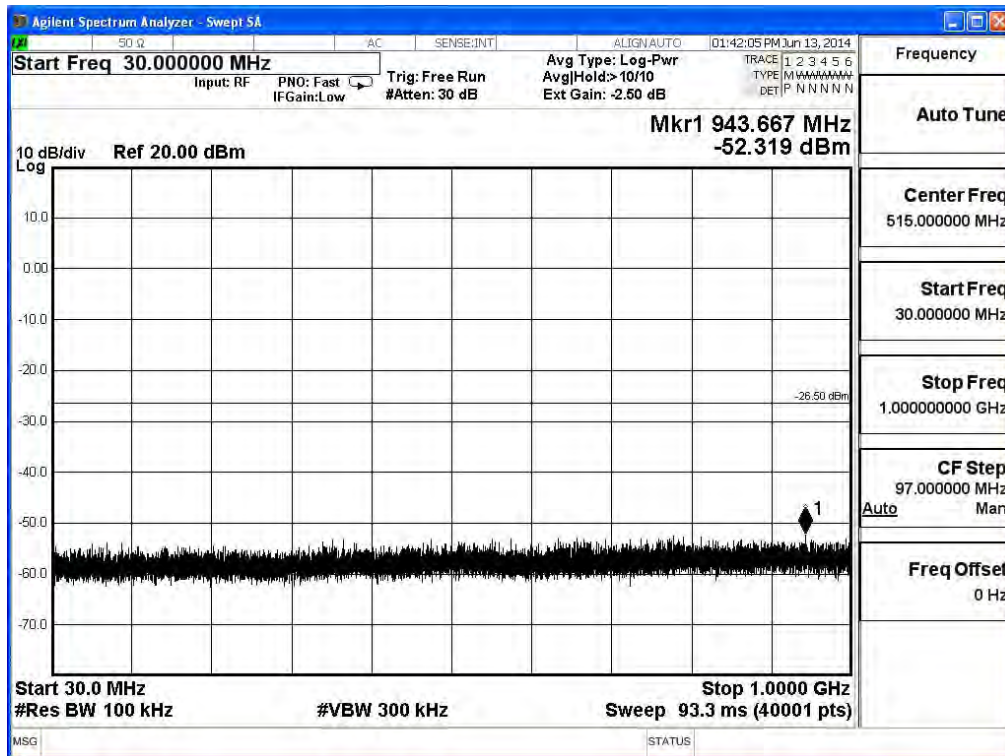

Channel 00 (1GHz-5GHz)- $\pi/4$ -DQPSK

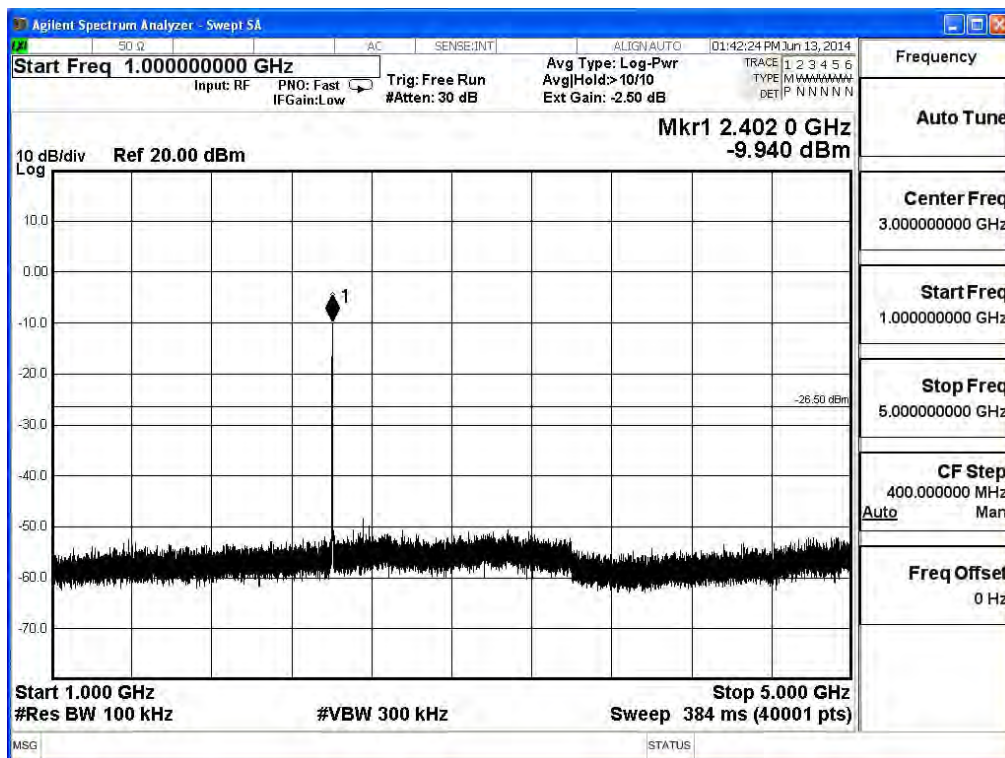

Product	SkyCaddie		
Test Item	RF antenna conducted test		
Test Mode	Mode 1: Transmit (Power by PC)		
Date of Test	2014/02/17	Test Site	SR7

Channel 00 (5GHz-9GHz)- $\pi/4$ -DQPSK

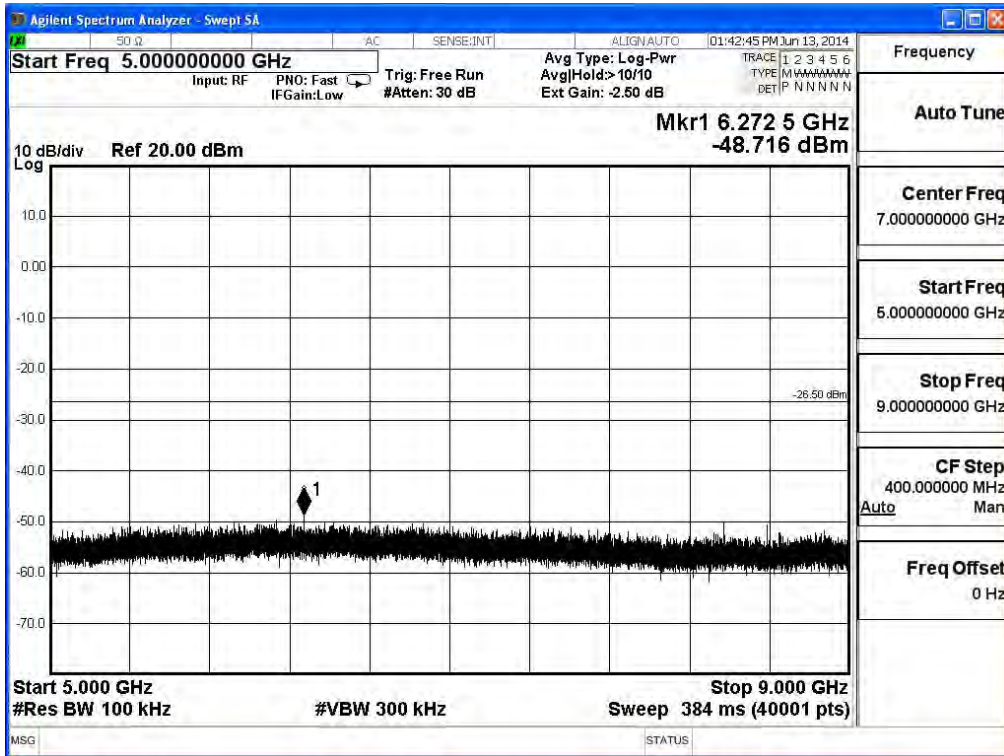

Channel 00 (9GHz~13GHz)- $\pi/4$ -DQPSK

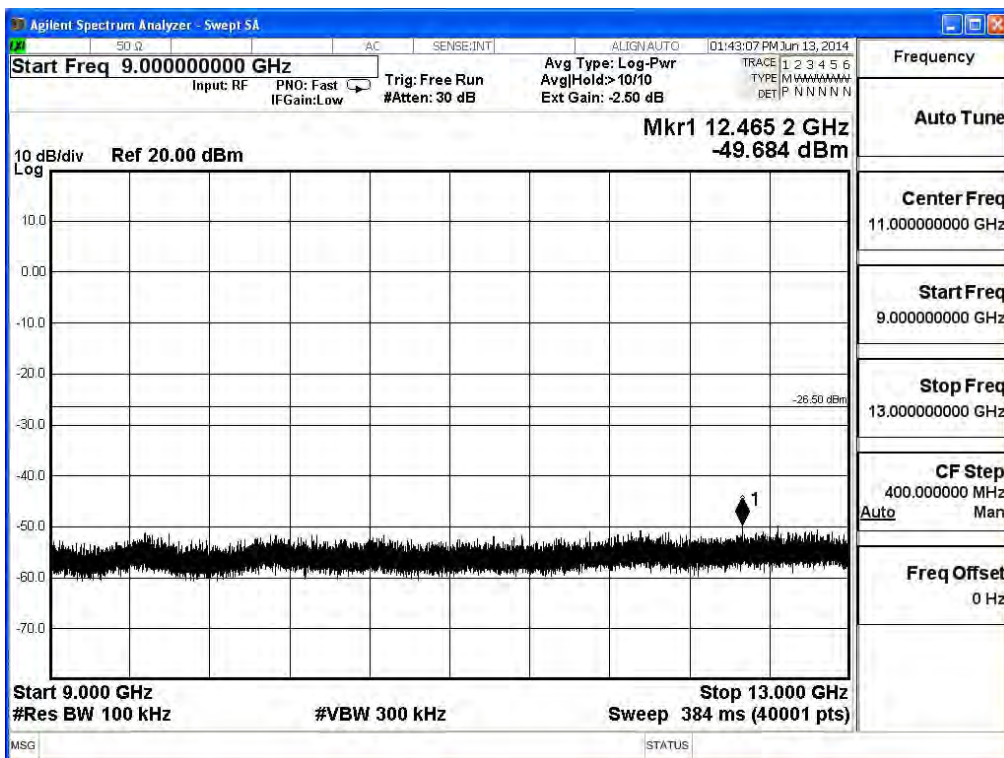

Product	SkyCaddie		
Test Item	RF antenna conducted test		
Test Mode	Mode 1: Transmit (Power by PC)		
Date of Test	2014/02/17	Test Site	SR7

Channel 00 (13GHz-17GHz)- $\pi/4$ -DQPSK

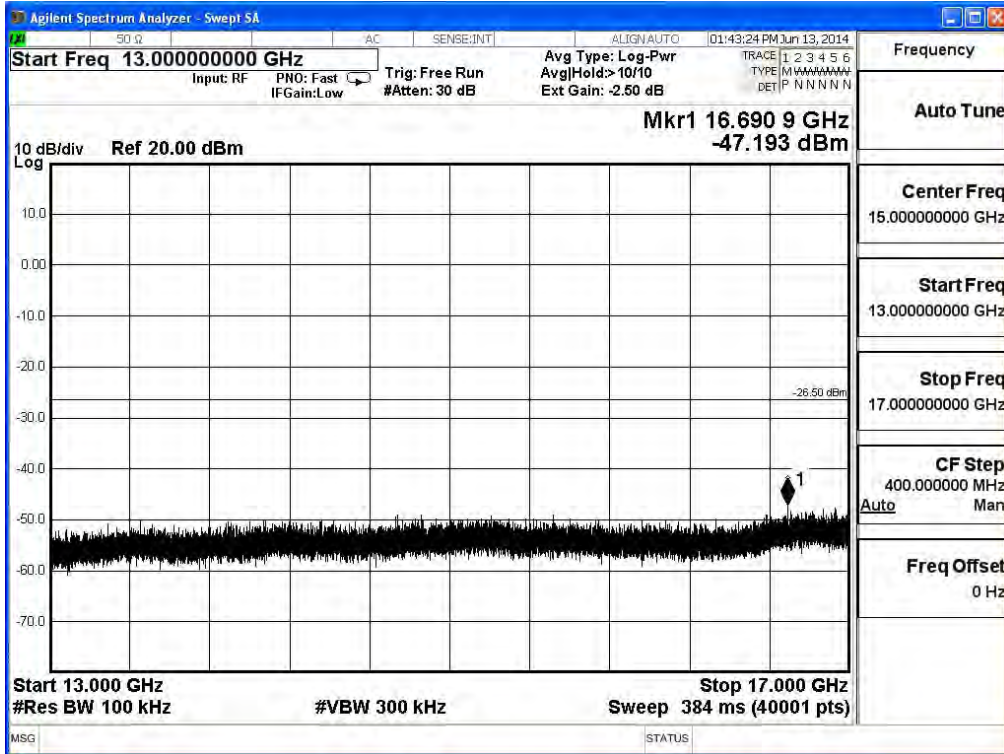

Channel 00 (17GHz~21GHz)- $\pi/4$ -DQPSK

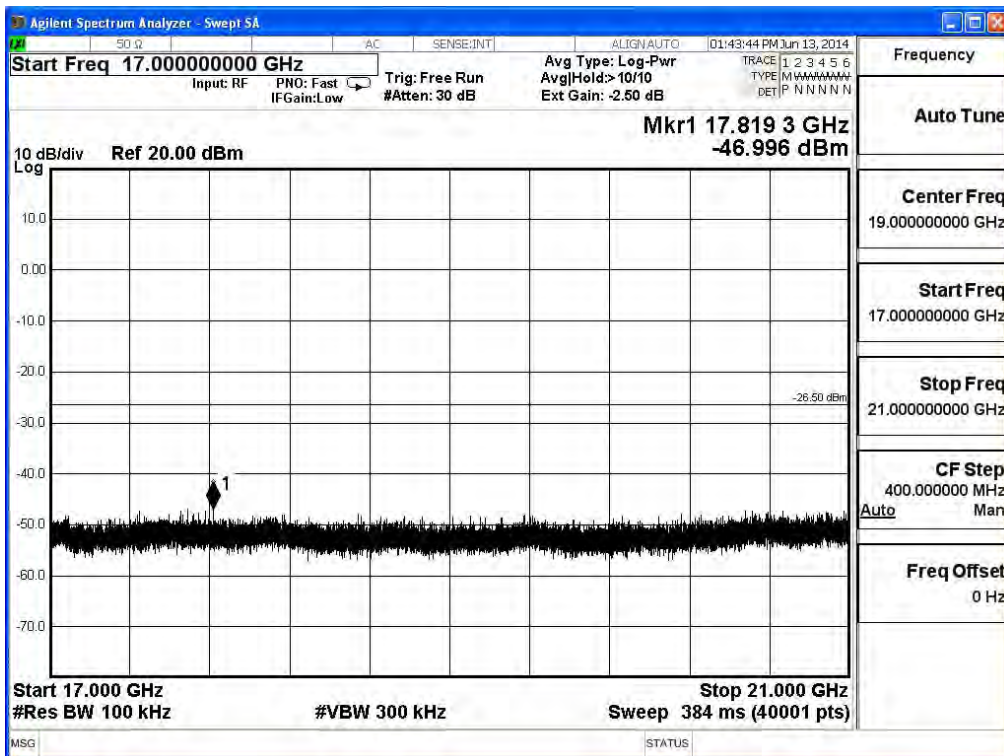

Channel 00 (21GHz~25GHz)- $\pi/4$ -DQPSK

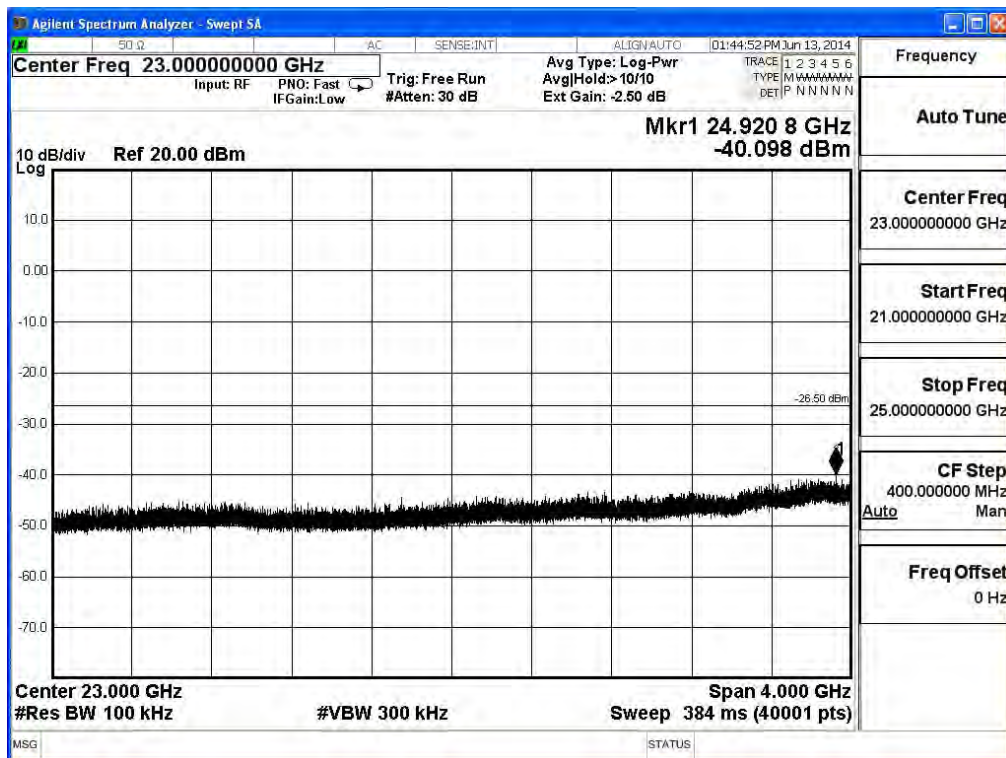

Product	SkyCaddie		
Test Item	RF antenna conducted test		
Test Mode	Mode 1: Transmit (Power by PC)		
Date of Test	2014/02/17	Test Site	SR7

Channel 39 (30MHz-1GHz)- $\pi/4$ -DQPSK

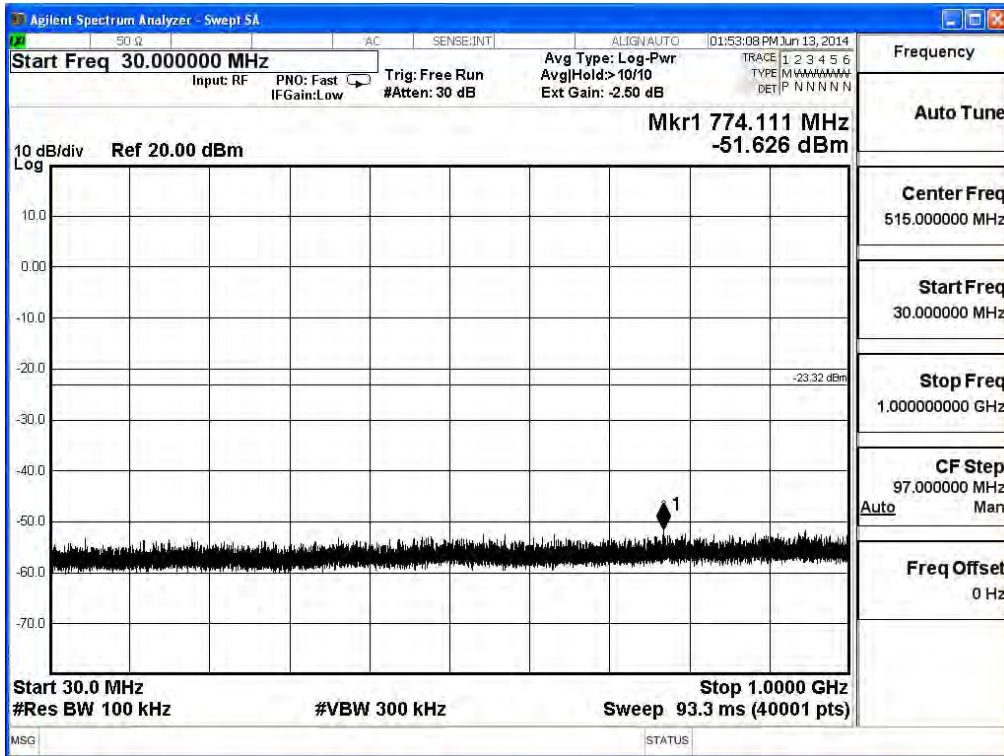

Channel 39 (1GHz~5GHz)- $\pi/4$ -DQPSK

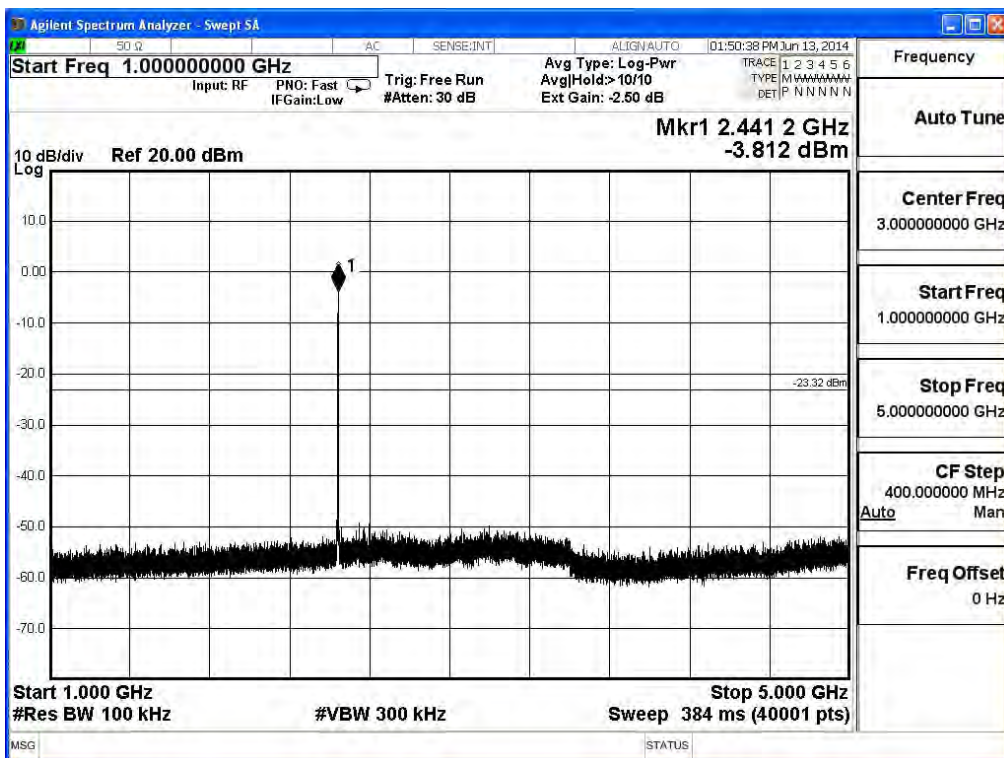

Product	SkyCaddie		
Test Item	RF antenna conducted test		
Test Mode	Mode 1: Transmit (Power by PC)		
Date of Test	2014/02/17	Test Site	SR7

Channel 39 (5GHz-9GHz)- $\pi/4$ -DQPSK

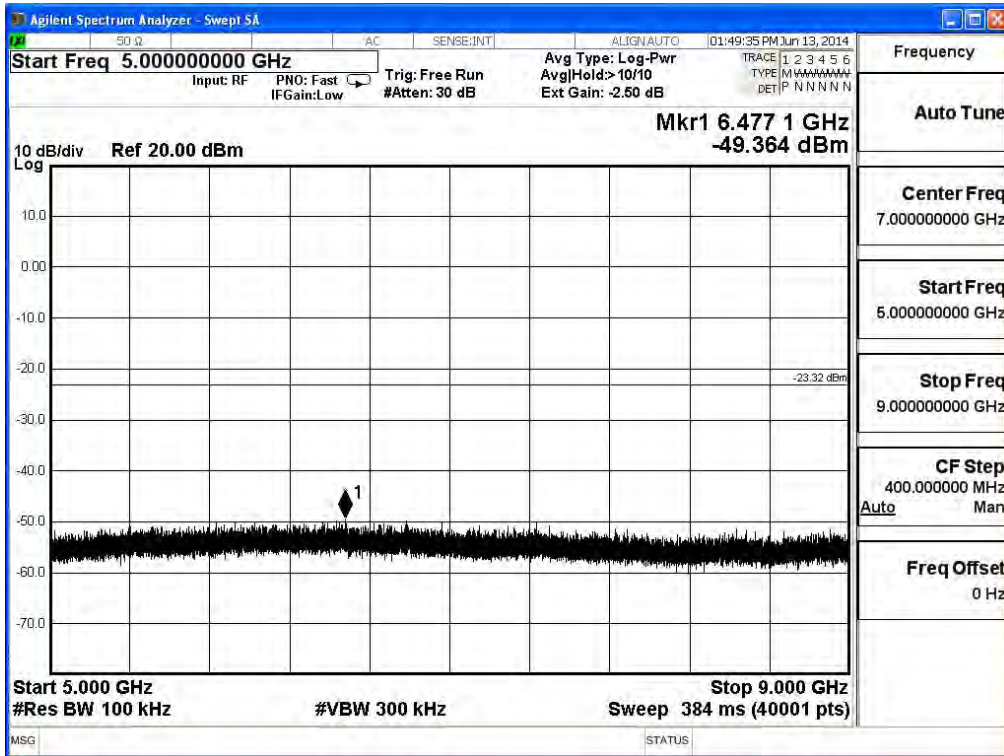

Channel 39 (9GHz~13GHz)- $\pi/4$ -DQPSK

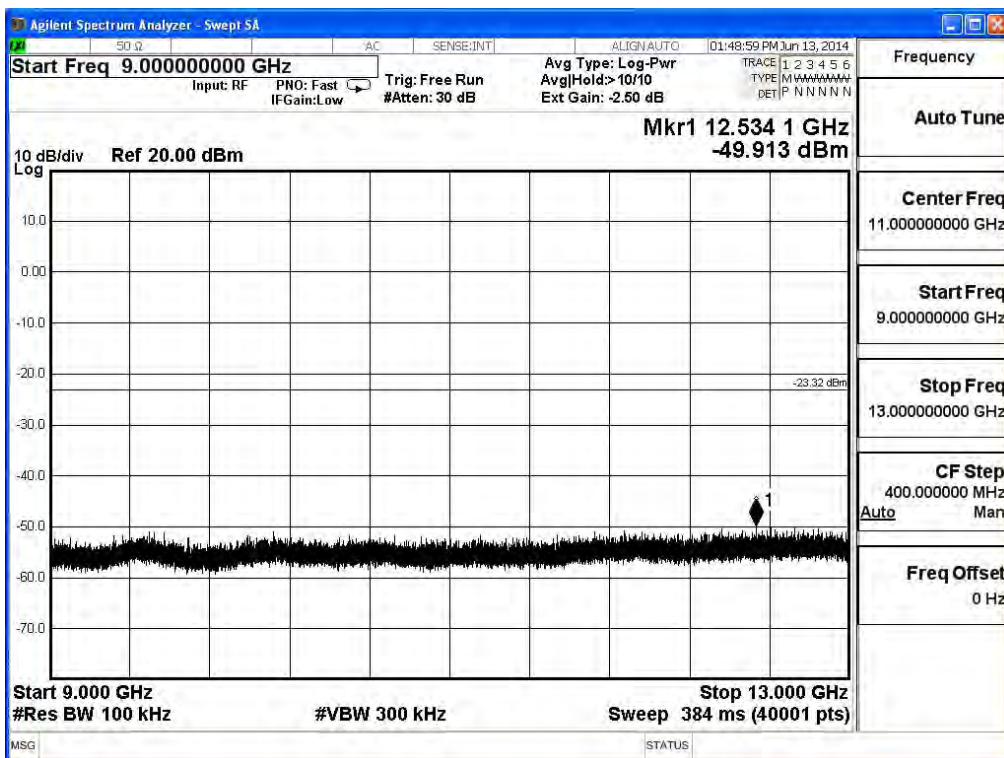

Product	SkyCaddie		
Test Item	RF antenna conducted test		
Test Mode	Mode 1: Transmit (Power by PC)		
Date of Test	2014/02/17	Test Site	SR7

Channel 39 (13GHz-17GHz)- $\pi/4$ -DQPSK

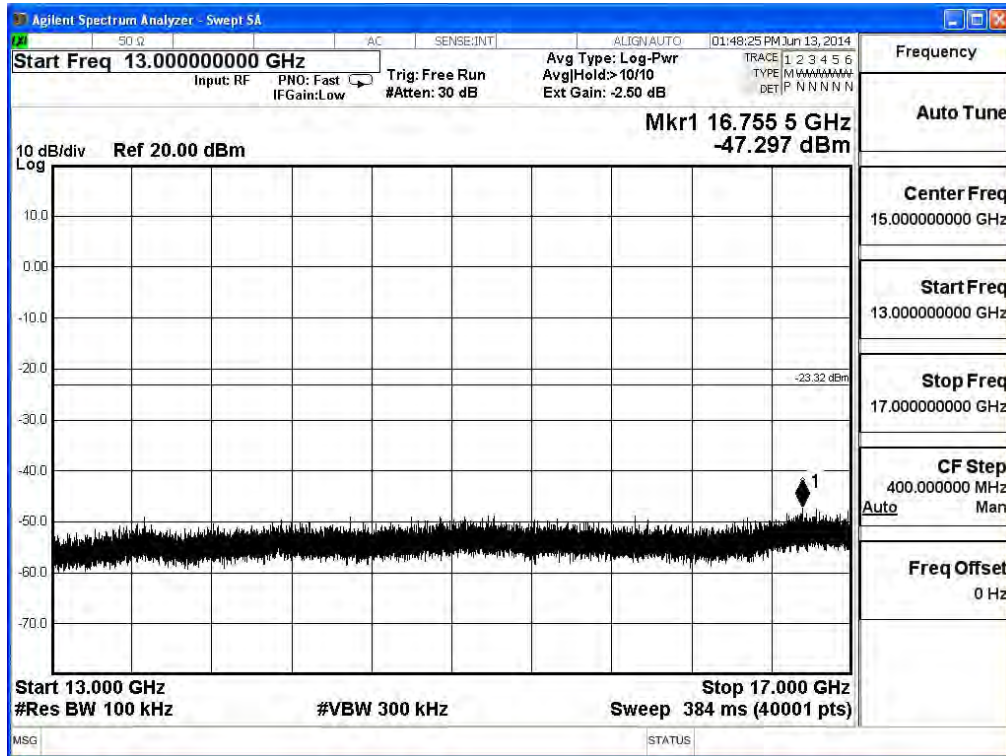

Channel 39 (17GHz~21GHz)- $\pi/4$ -DQPSK

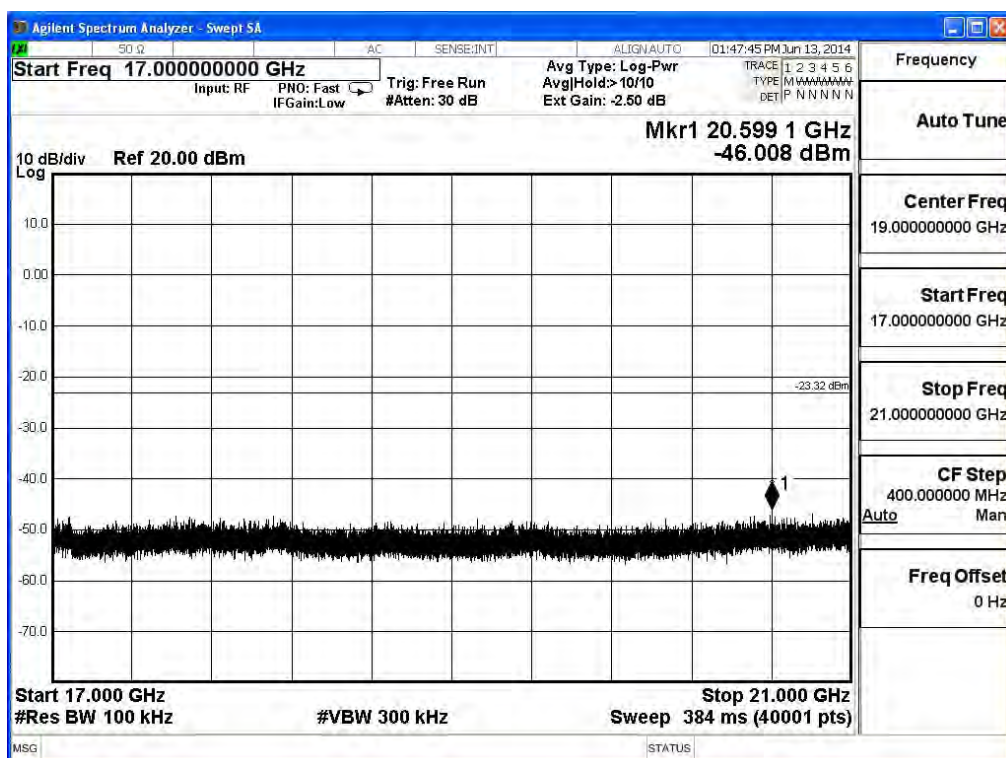

Channel 39 (21GHz~25GHz)- $\pi/4$ -DQPSK

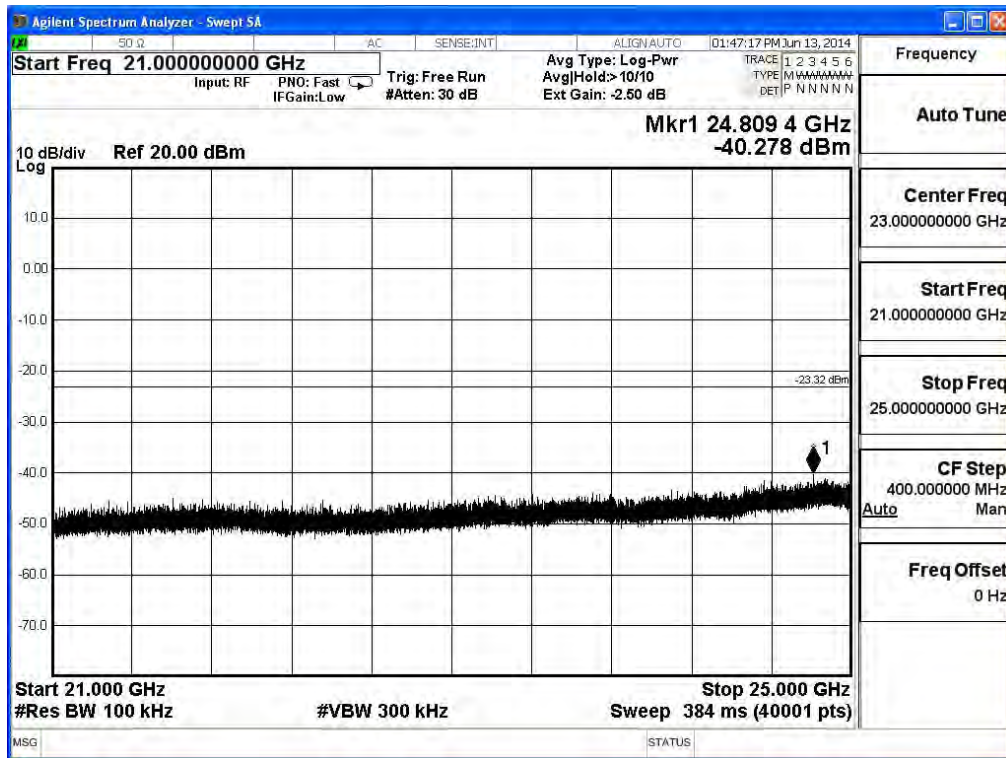

Product	SkyCaddie		
Test Item	RF antenna conducted test		
Test Mode	Mode 1: Transmit (Power by PC)		
Date of Test	2014/02/17	Test Site	SR7

Channel 78 (30MHz-1GHz)- $\pi/4$ -DQPSK

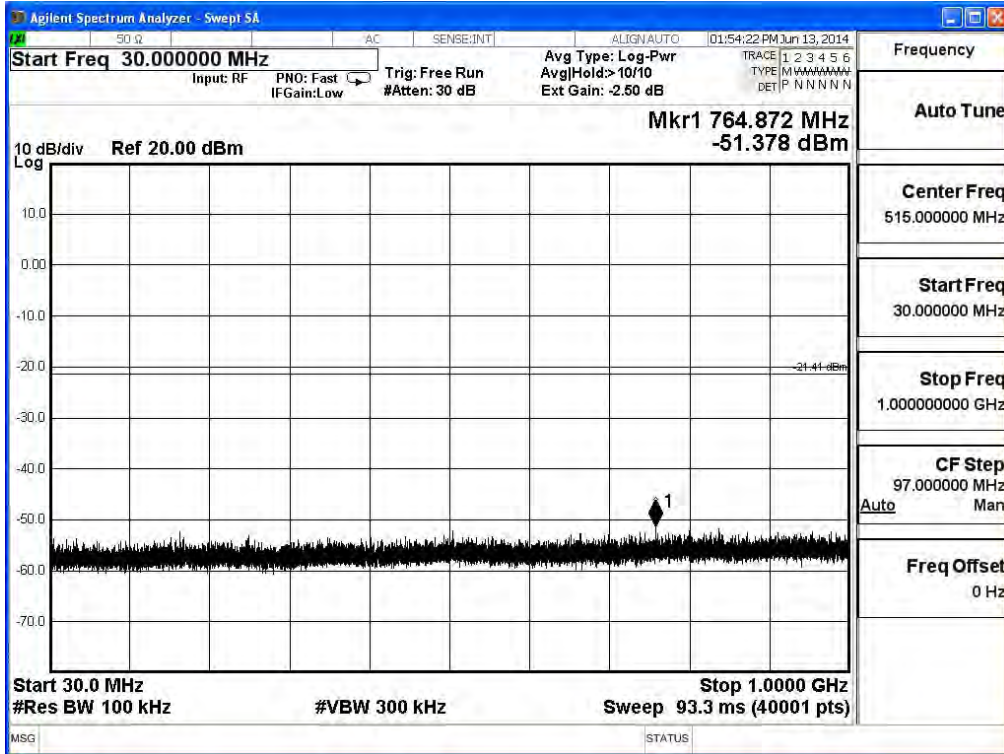

Channel 78 (1GHz~5GHz)- $\pi/4$ -DQPSK

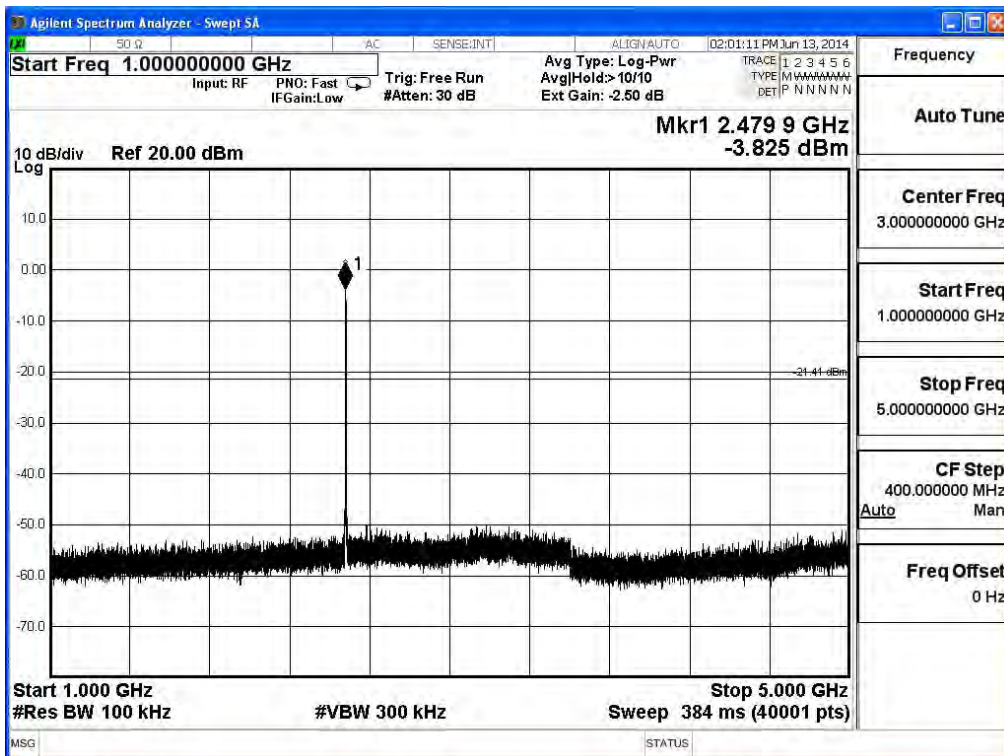

Product	SkyCaddie		
Test Item	RF antenna conducted test		
Test Mode	Mode 1: Transmit (Power by PC)		
Date of Test	2014/02/17	Test Site	SR7

Channel 78 (5GHz-9GHz)- $\pi/4$ -DQPSK

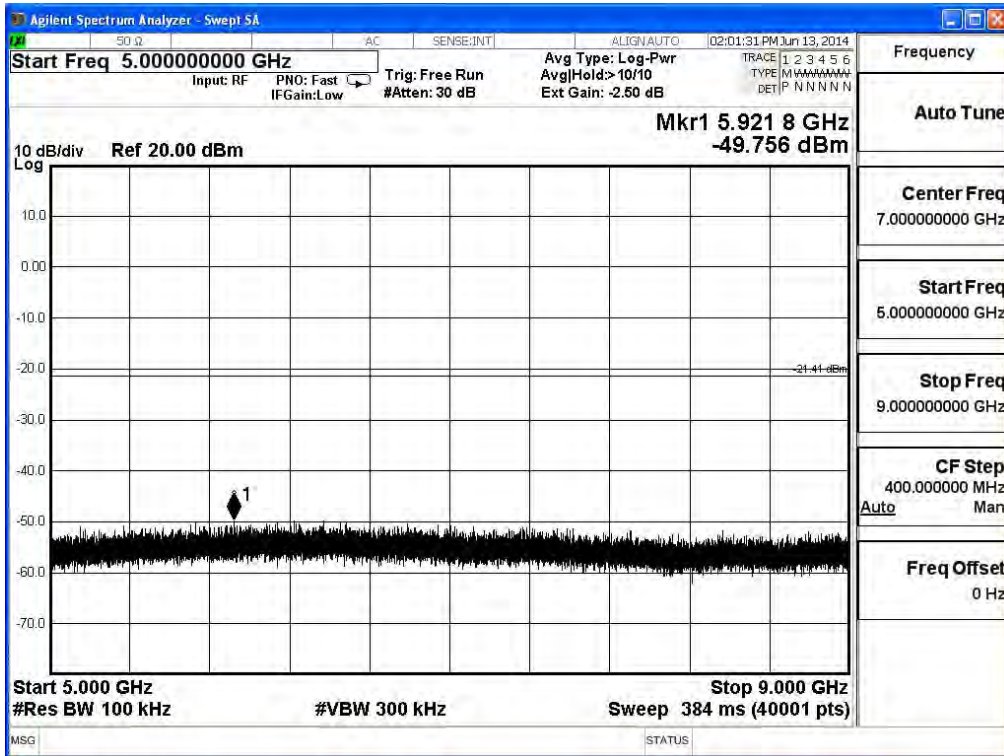

Channel 78 (9GHz~13GHz)- $\pi/4$ -DQPSK

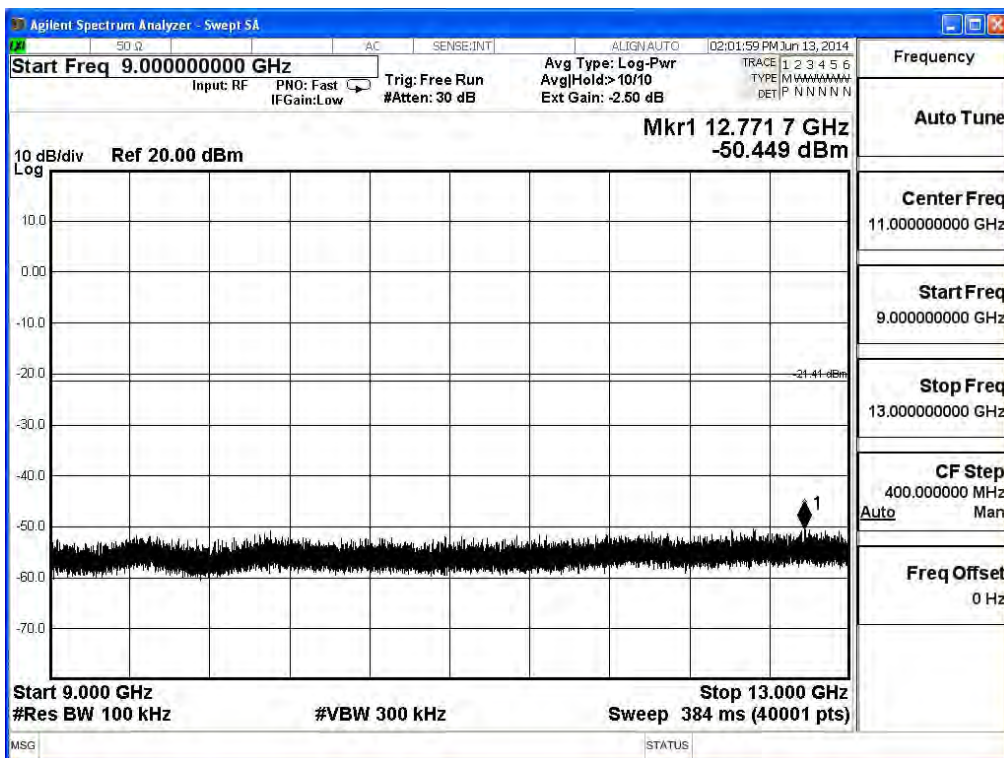

Product	SkyCaddie		
Test Item	RF antenna conducted test		
Test Mode	Mode 1: Transmit (Power by PC)		
Date of Test	2014/02/17	Test Site	SR7

Channel 78 (13GHz-17GHz)- $\pi/4$ -DQPSK

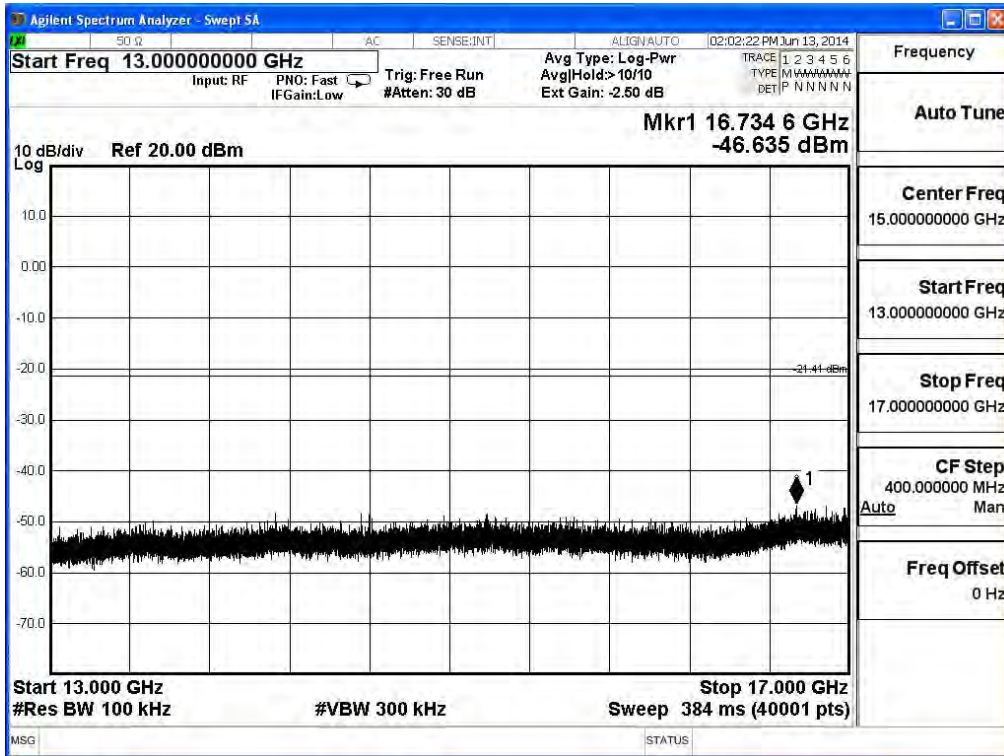

Channel 78 (17GHz~21GHz)- $\pi/4$ -DQPSK

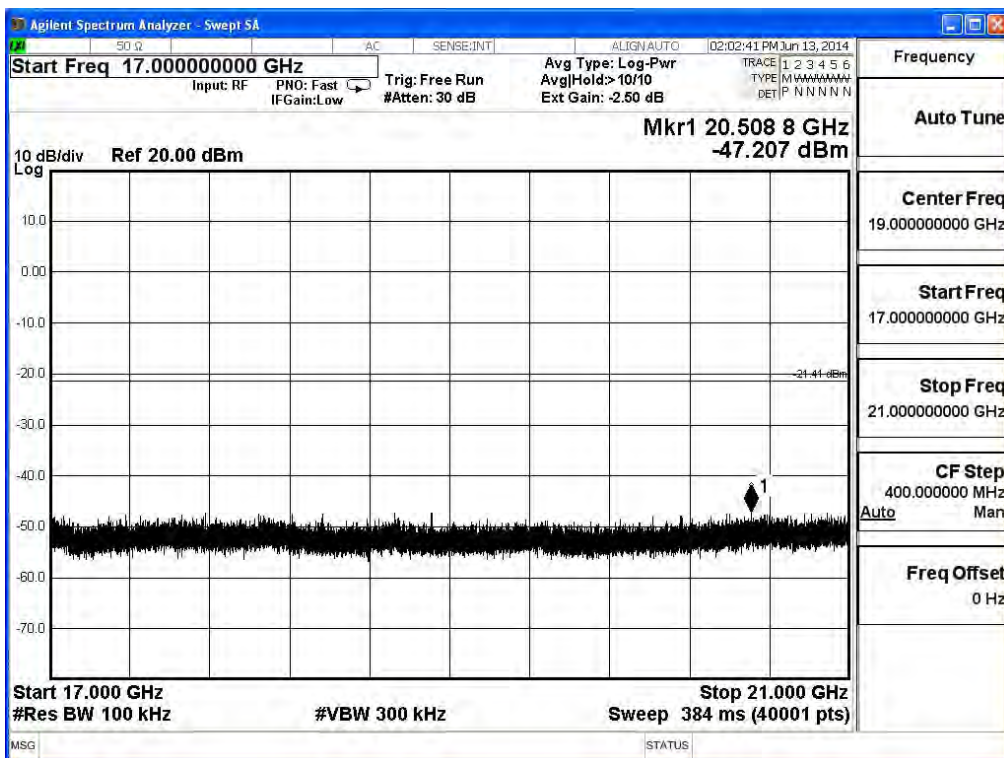

Product	SkyCaddie		
Test Item	RF antenna conducted test		
Test Mode	Mode 1: Transmit (Power by PC)		
Date of Test	2014/02/17	Test Site	SR7

Channel 78 (21GHz-25GHz)- $\pi/4$ -DQPSK

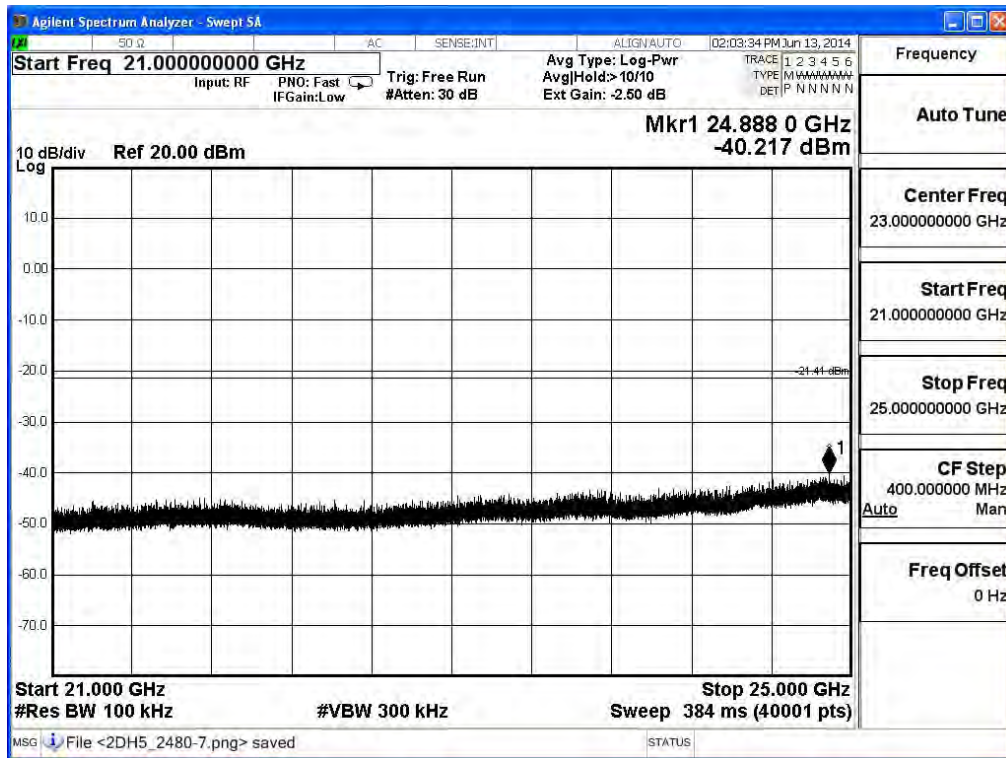

Product	SkyCaddie		
Test Item	RF antenna conducted test		
Test Mode	Mode 1: Transmit (Power by PC)		
Date of Test	2014/02/17	Test Site	SR7

Channel 00 (30MHz-1GHz)- 8-DQPSK

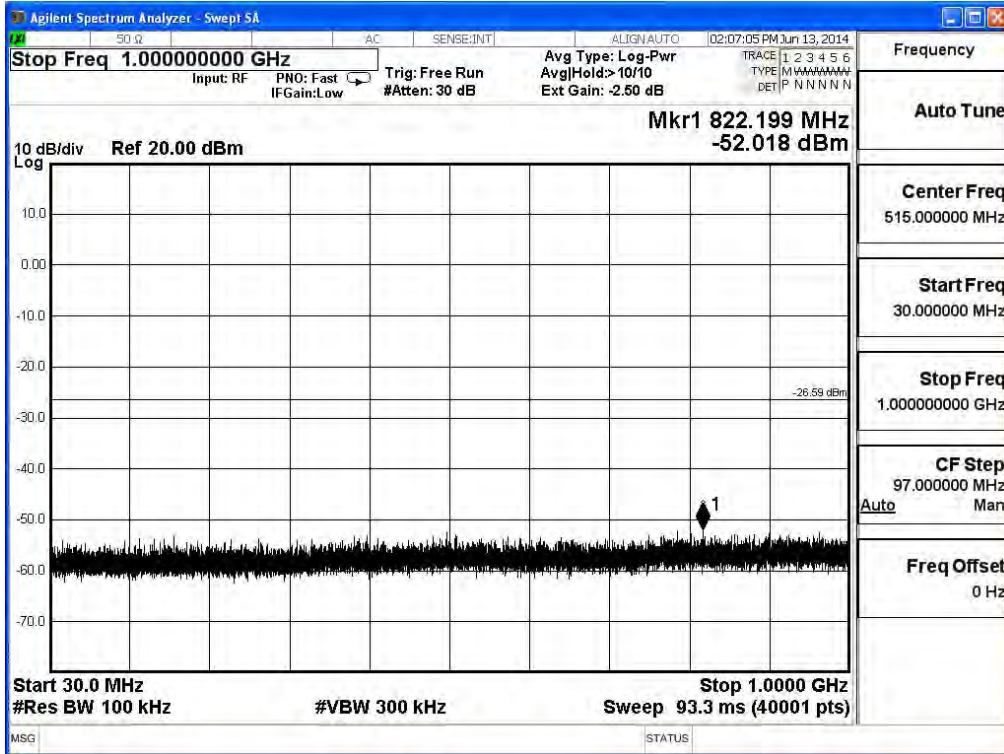

Channel 00 (1GHz~5GHz)- 8-DQPSK

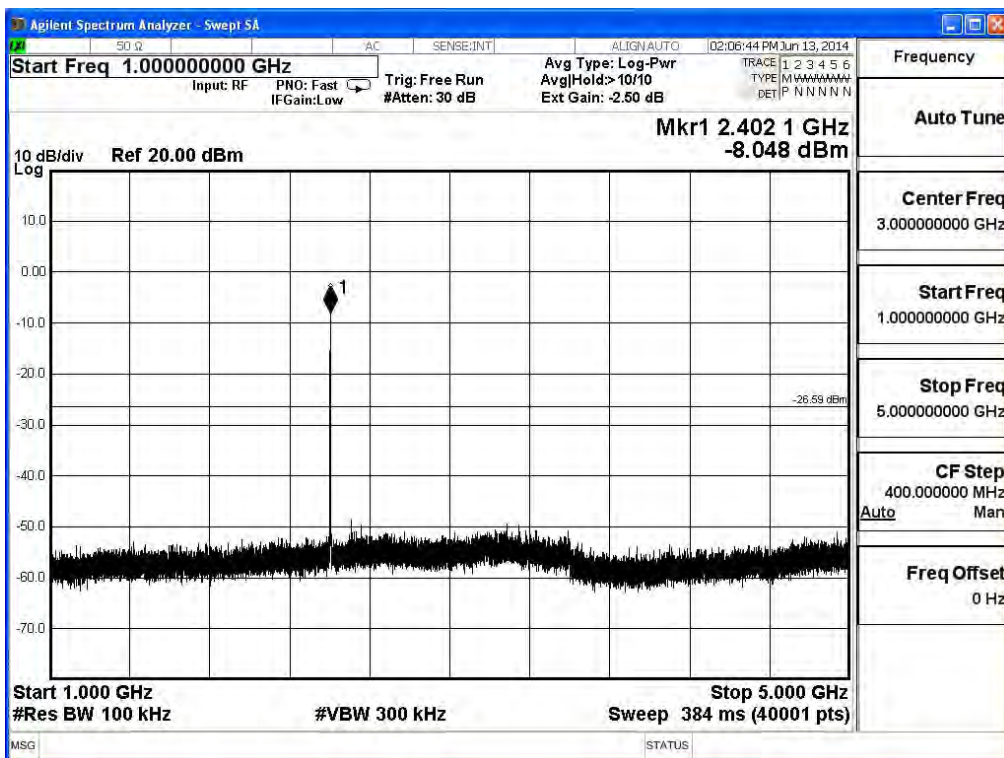

Product	SkyCaddie		
Test Item	RF antenna conducted test		
Test Mode	Mode 1: Transmit (Power by PC)		
Date of Test	2014/02/17	Test Site	SR7

Channel 00 (5GHz-9GHz)- 8-DQPSK

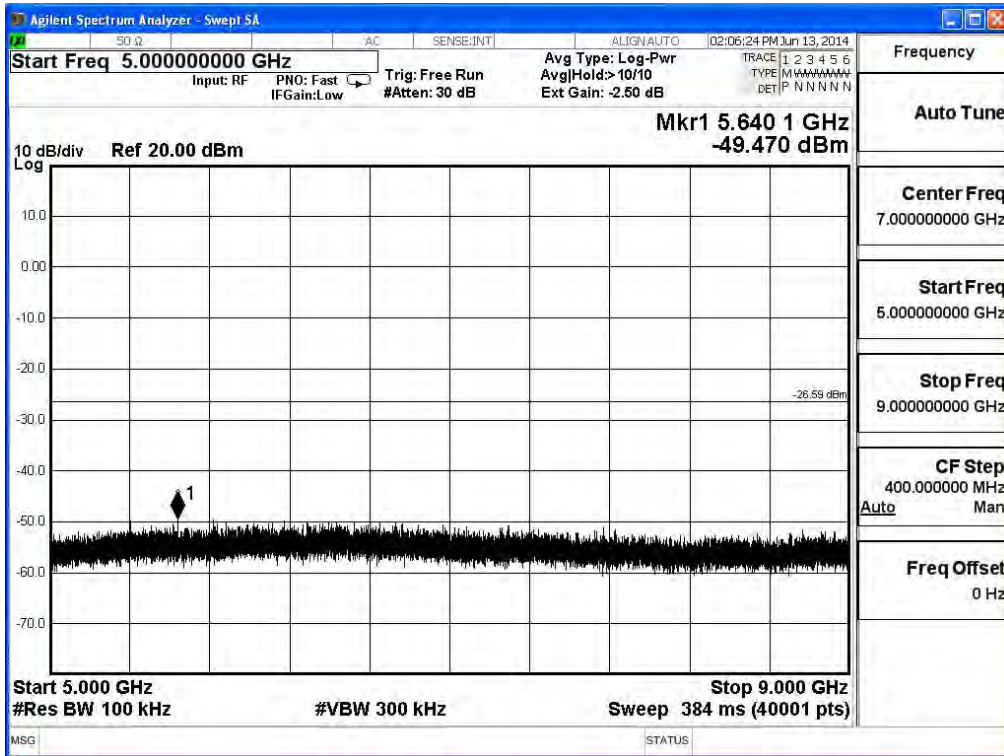

Channel 00 (9GHz~13GHz)- 8-DQPSK

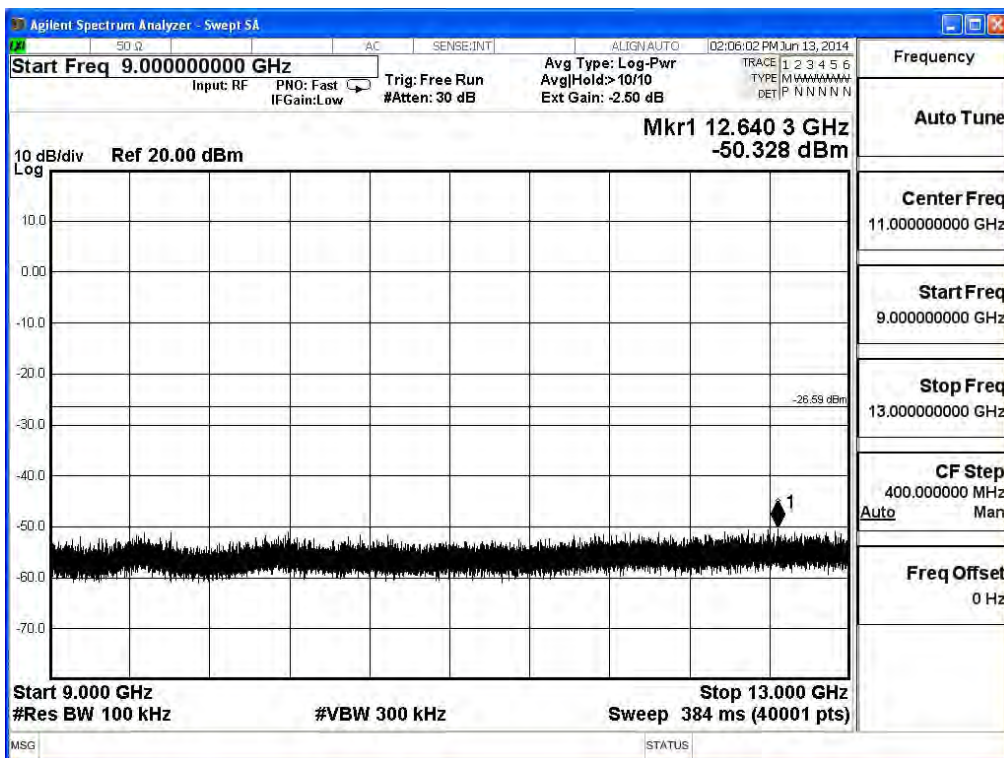

Product	SkyCaddie		
Test Item	RF antenna conducted test		
Test Mode	Mode 1: Transmit (Power by PC)		
Date of Test	2014/02/17	Test Site	SR7

Channel 00 (13GHz-17GHz)- 8-DQPSK

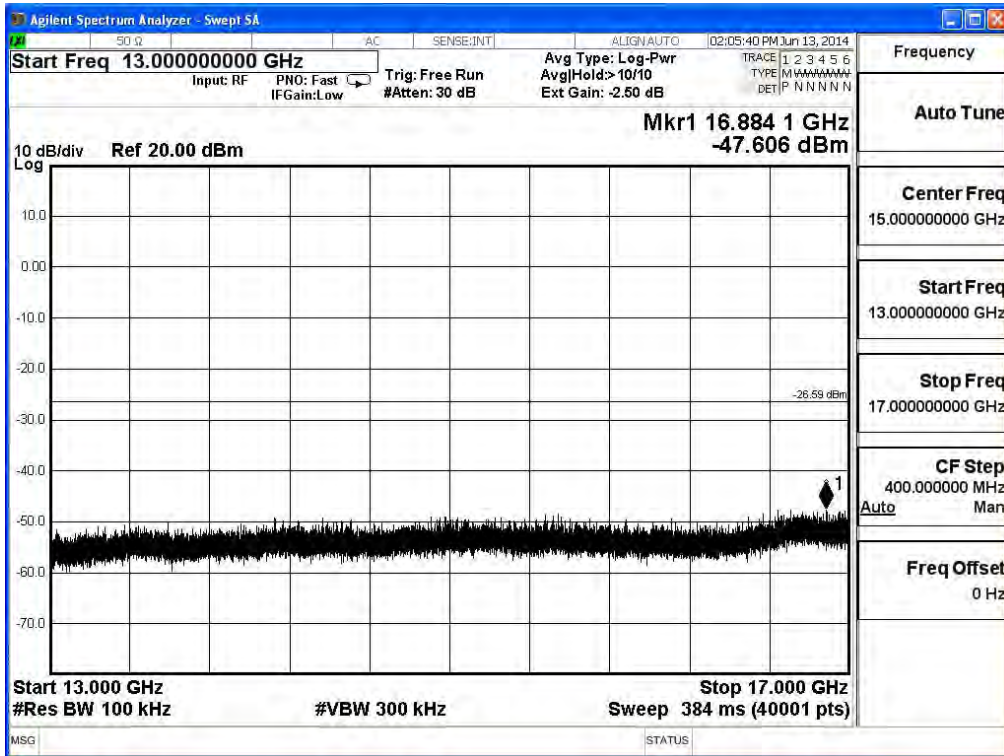

Channel 00 (17GHz~21GHz)- 8-DQPSK

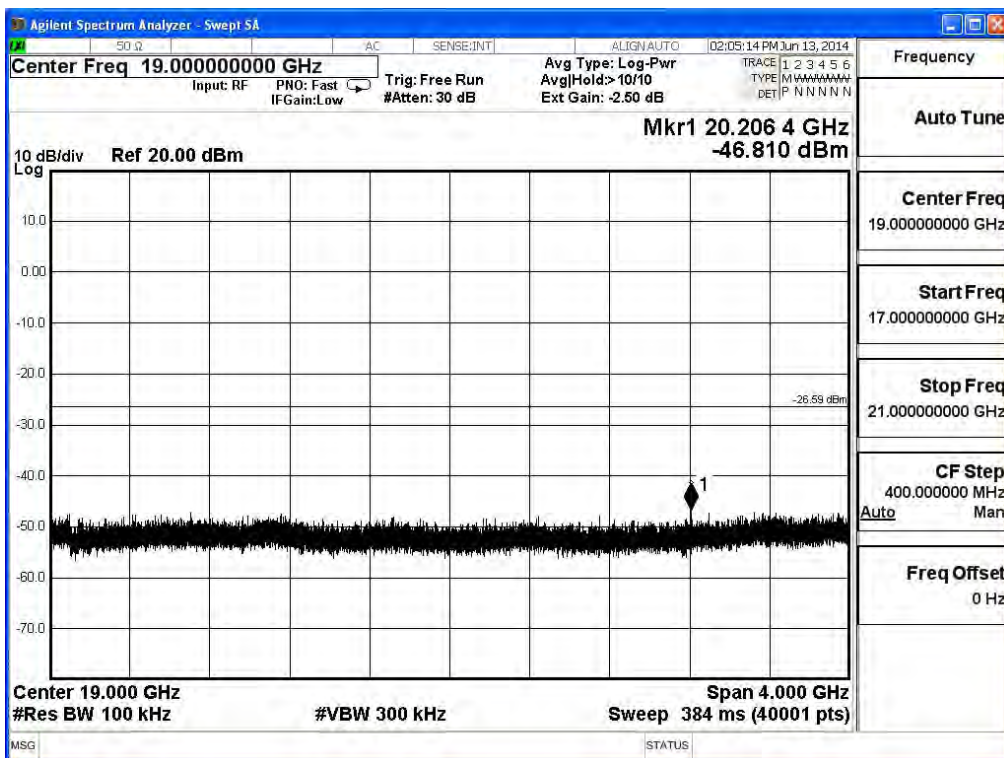

Product	SkyCaddie		
Test Item	RF antenna conducted test		
Test Mode	Mode 1: Transmit (Power by PC)		
Date of Test	2014/02/17	Test Site	SR7

Channel 00 (21GHz-25GHz)- 8-DQPSK

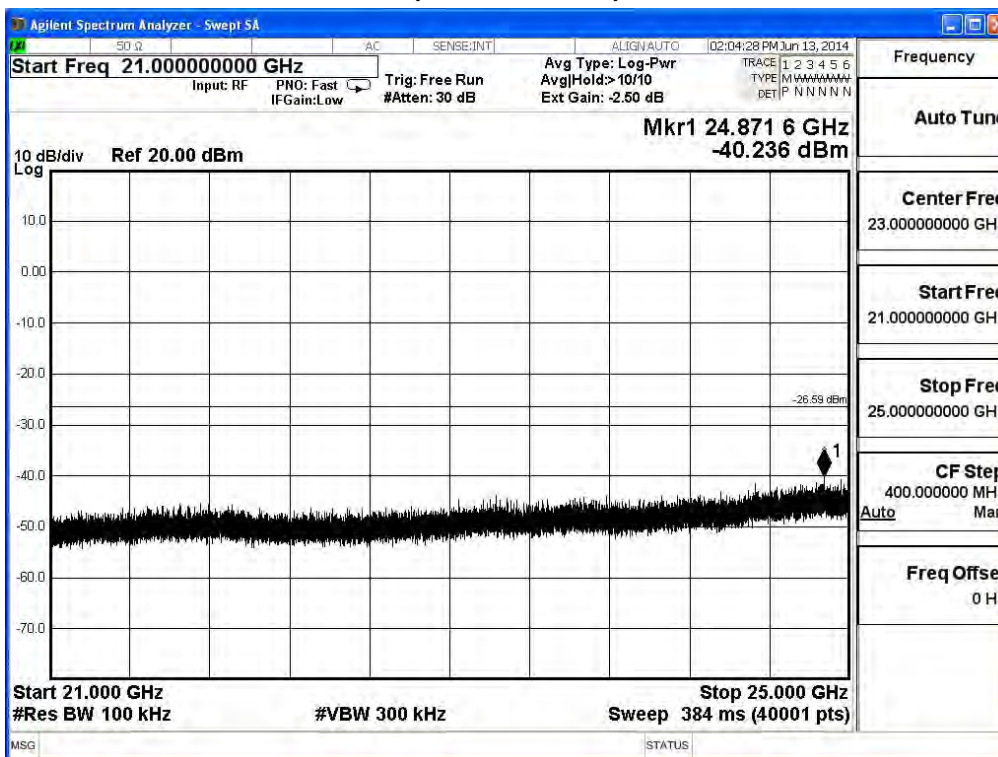

Product	SkyCaddie		
Test Item	RF antenna conducted test		
Test Mode	Mode 1: Transmit (Power by PC)		
Date of Test	2014/02/17	Test Site	SR7

Channel 39 (30MHz-1GHz)- 8-DQPSK

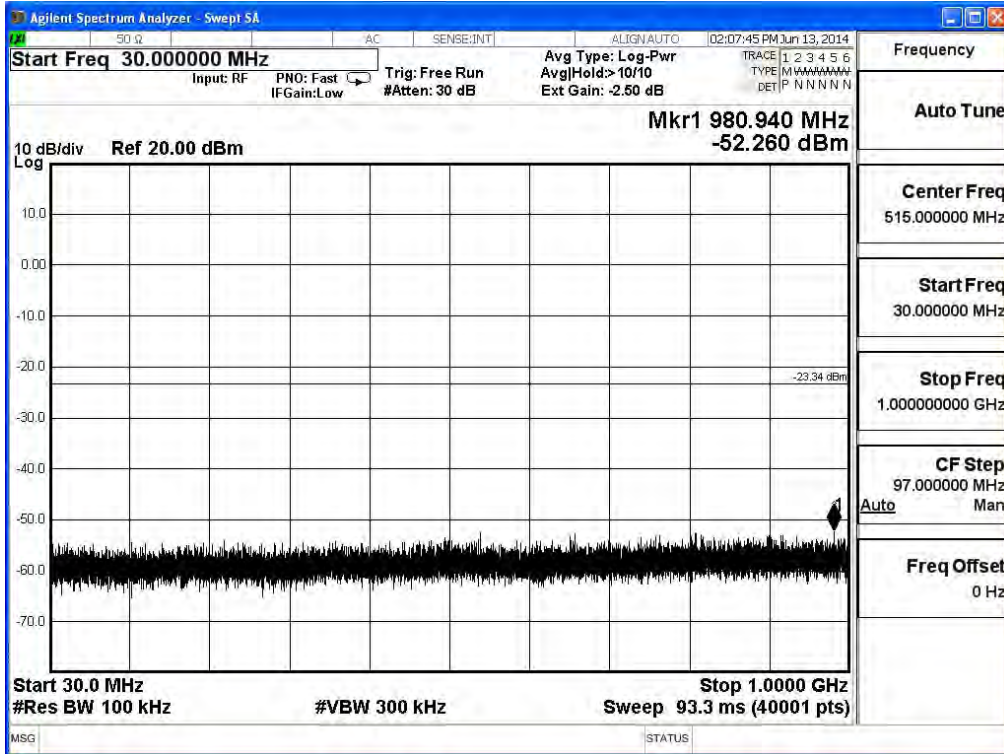

Channel 39 (1GHz~5GHz)- 8-DQPSK

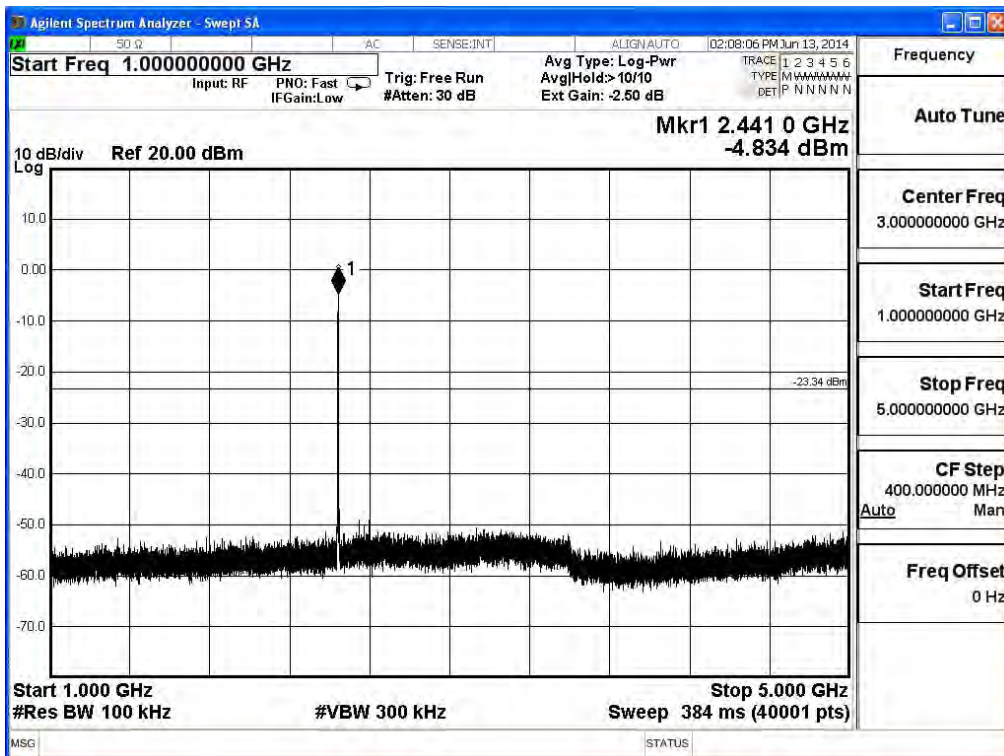

Product	SkyCaddie		
Test Item	RF antenna conducted test		
Test Mode	Mode 1: Transmit (Power by PC)		
Date of Test	2014/02/17	Test Site	SR7

Channel 39 (5GHz-9GHz)- 8-DQPSK

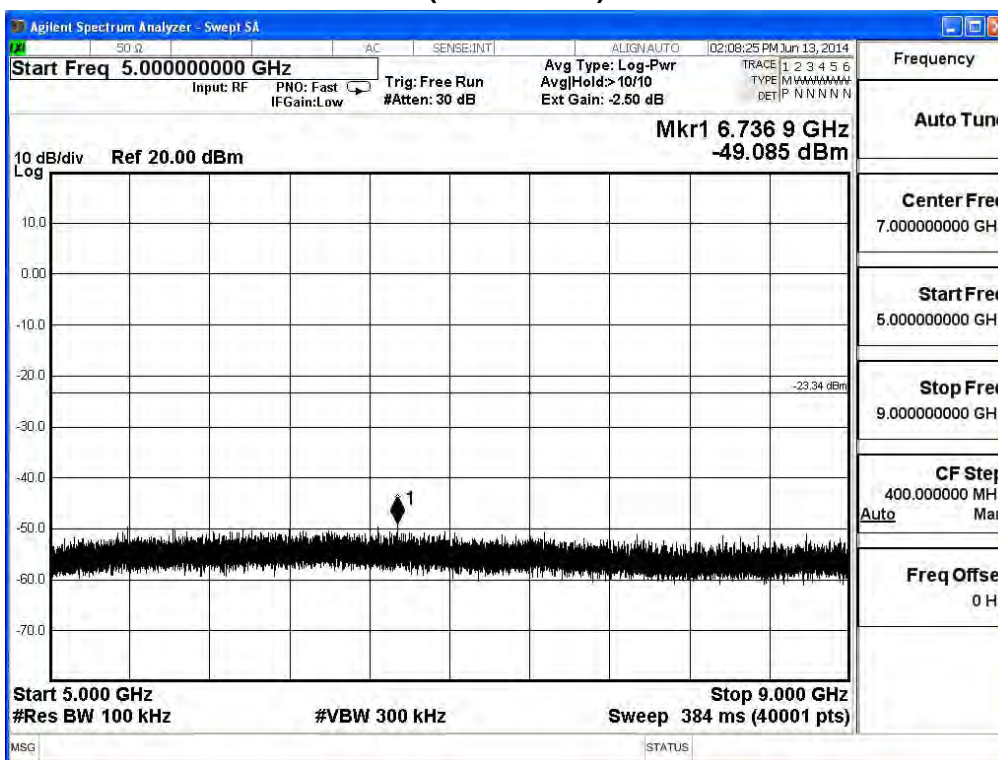

Channel 39 (9GHz~13GHz)- 8-DQPSK

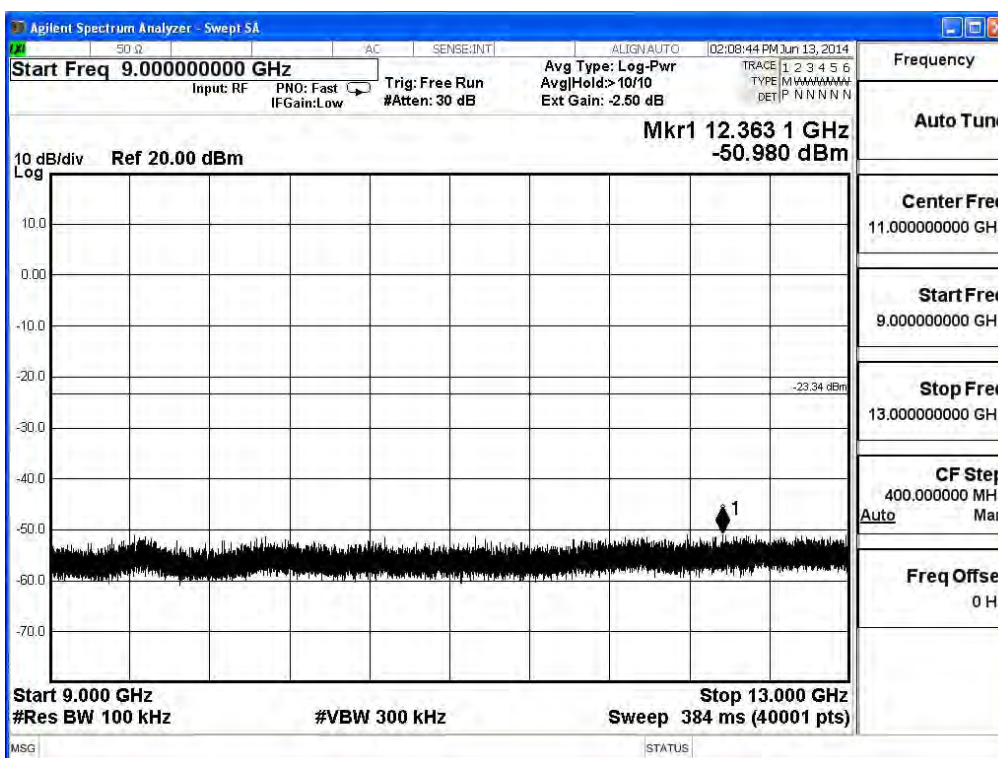

Product	SkyCaddie		
Test Item	RF antenna conducted test		
Test Mode	Mode 1: Transmit (Power by PC)		
Date of Test	2014/02/17	Test Site	SR7

Channel 39 (13GHz-17GHz)- 8-DQPSK

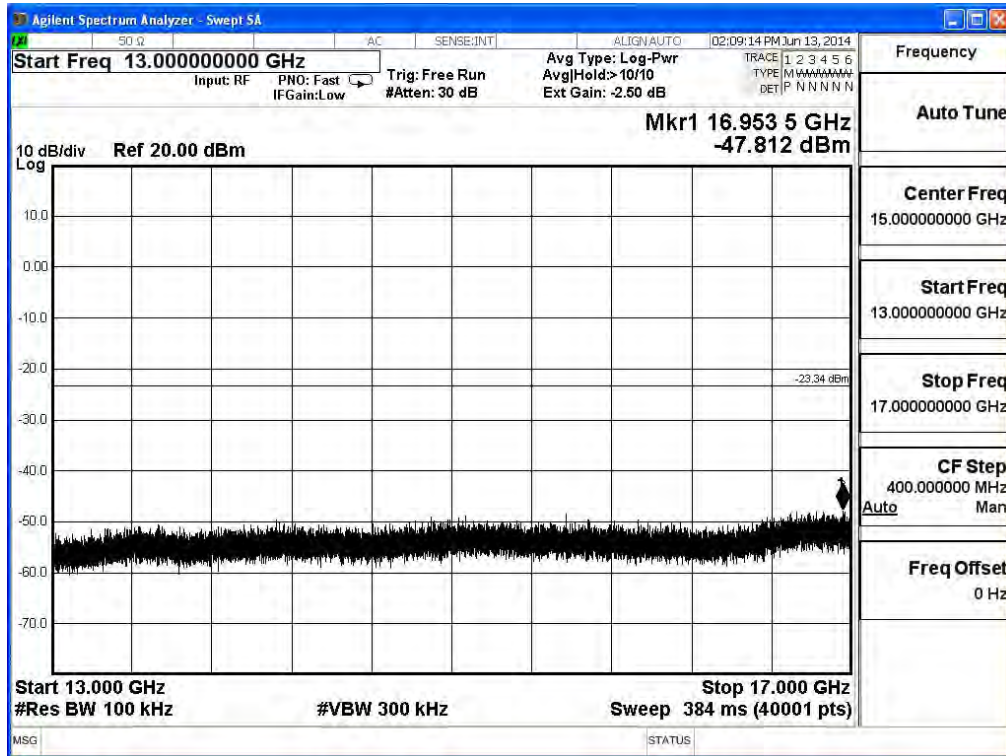

Channel 39 (17GHz~21GHz)- 8-DQPSK

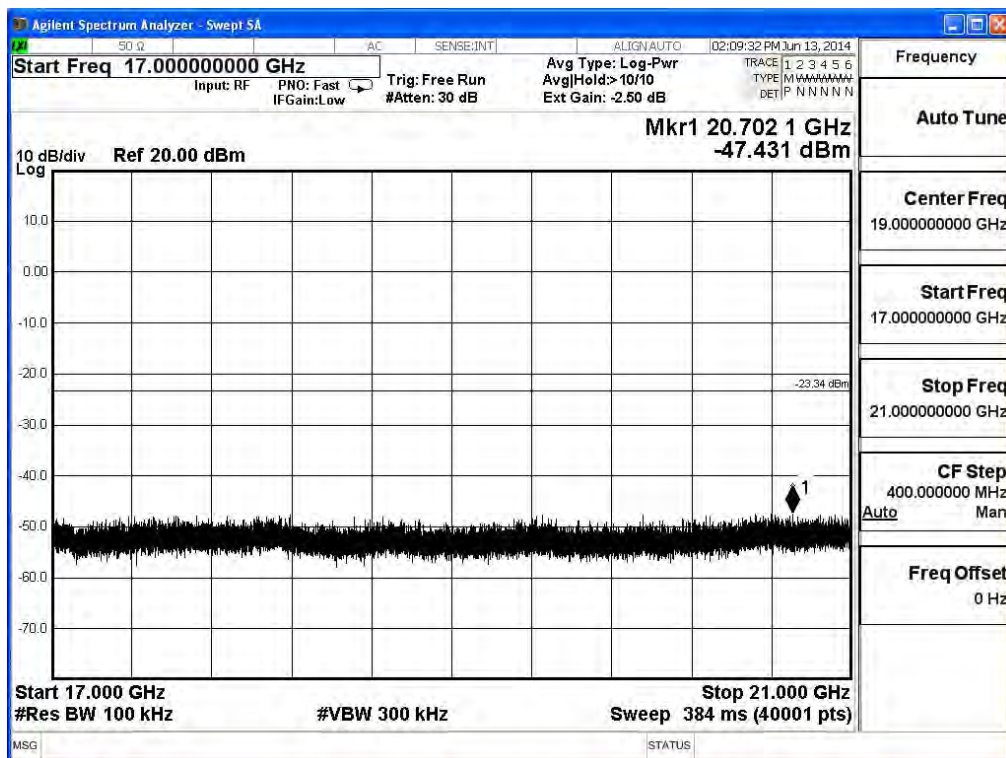

Product	SkyCaddie		
Test Item	RF antenna conducted test		
Test Mode	Mode 1: Transmit (Power by PC)		
Date of Test	2014/02/17	Test Site	SR7

Channel 39 (21GHz-25GHz)- 8-DQPSK

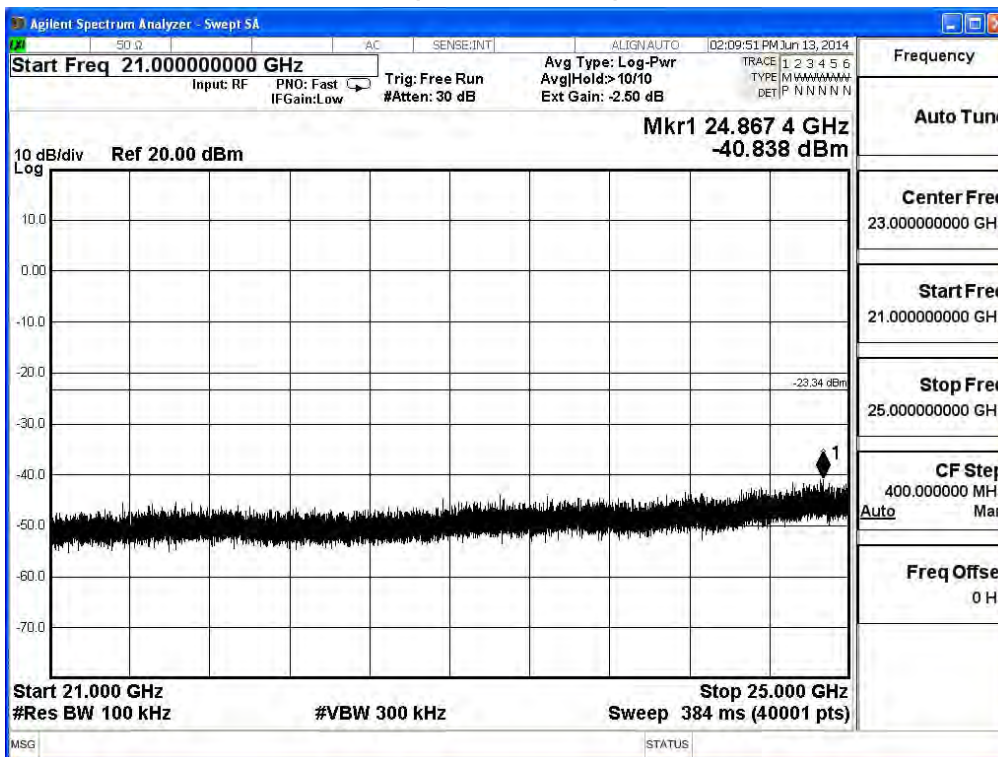

Product	SkyCaddie		
Test Item	RF antenna conducted test		
Test Mode	Mode 1: Transmit (Power by PC)		
Date of Test	2014/02/17	Test Site	SR7

Channel 78 (30MHz-1GHz)- 8-DQPSK

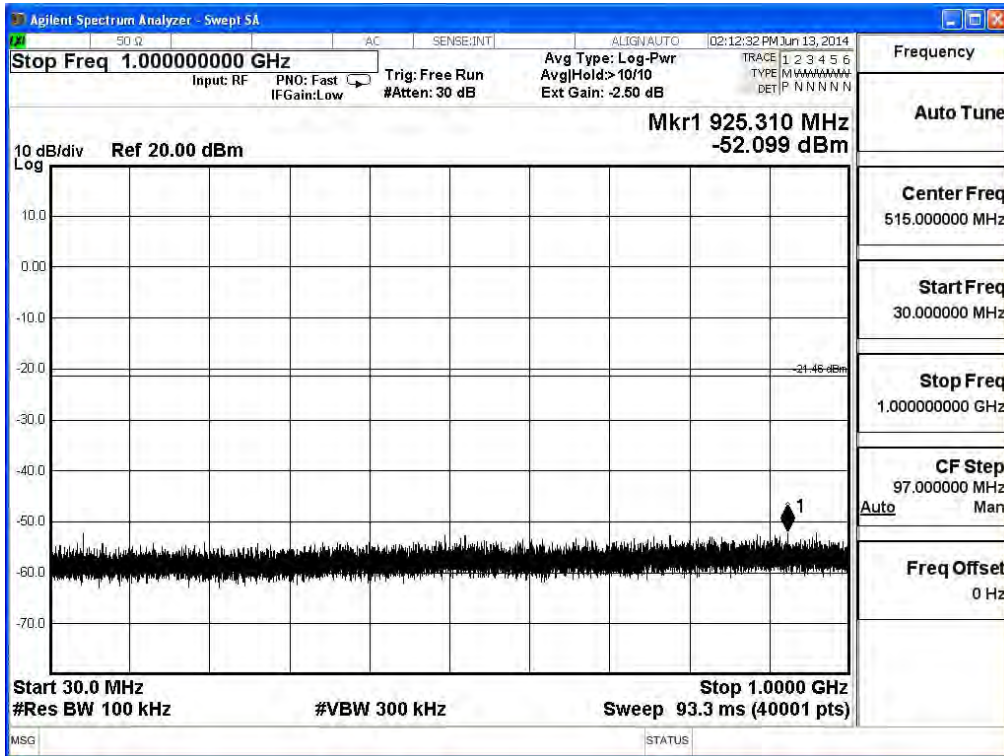

Channel 78 (1GHz~5GHz)- 8-DQPSK

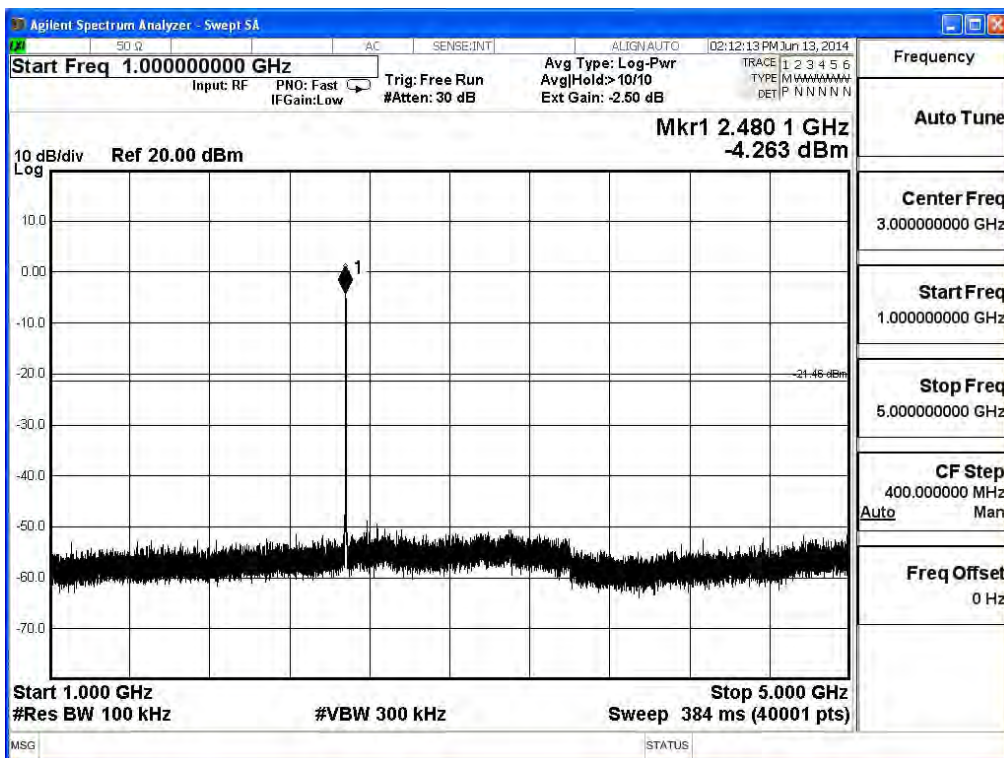

Product	SkyCaddie		
Test Item	RF antenna conducted test		
Test Mode	Mode 1: Transmit (Power by PC)		
Date of Test	2014/02/17	Test Site	SR7

Channel 78 (5GHz-9GHz)- 8-DQPSK

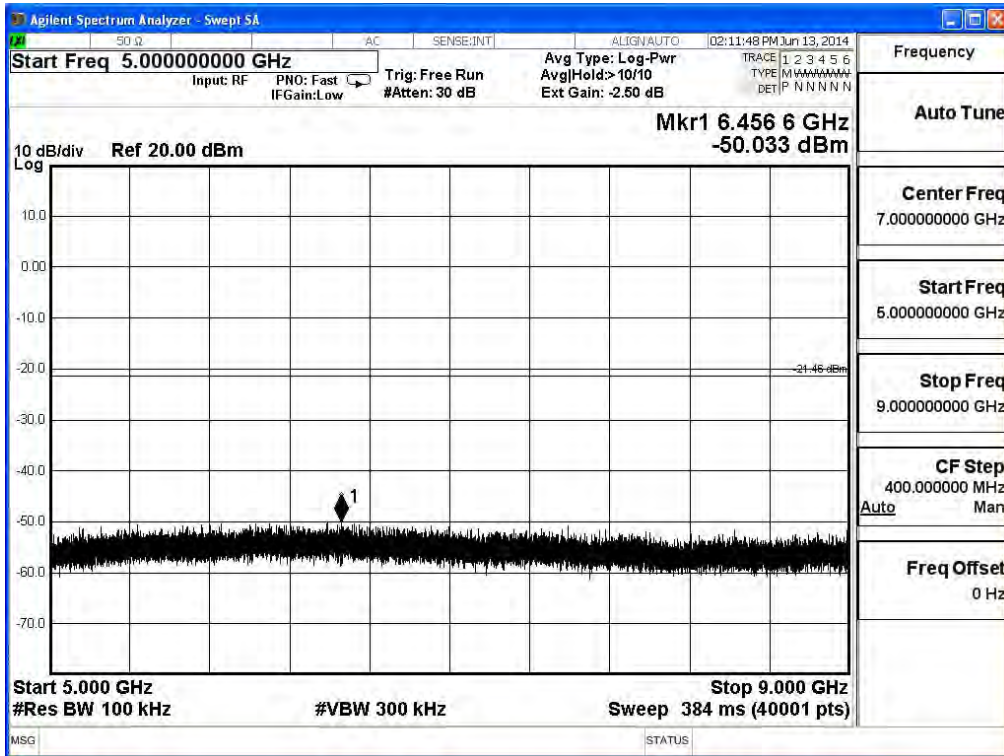

Channel 78 (9GHz~13GHz)- 8-DQPSK

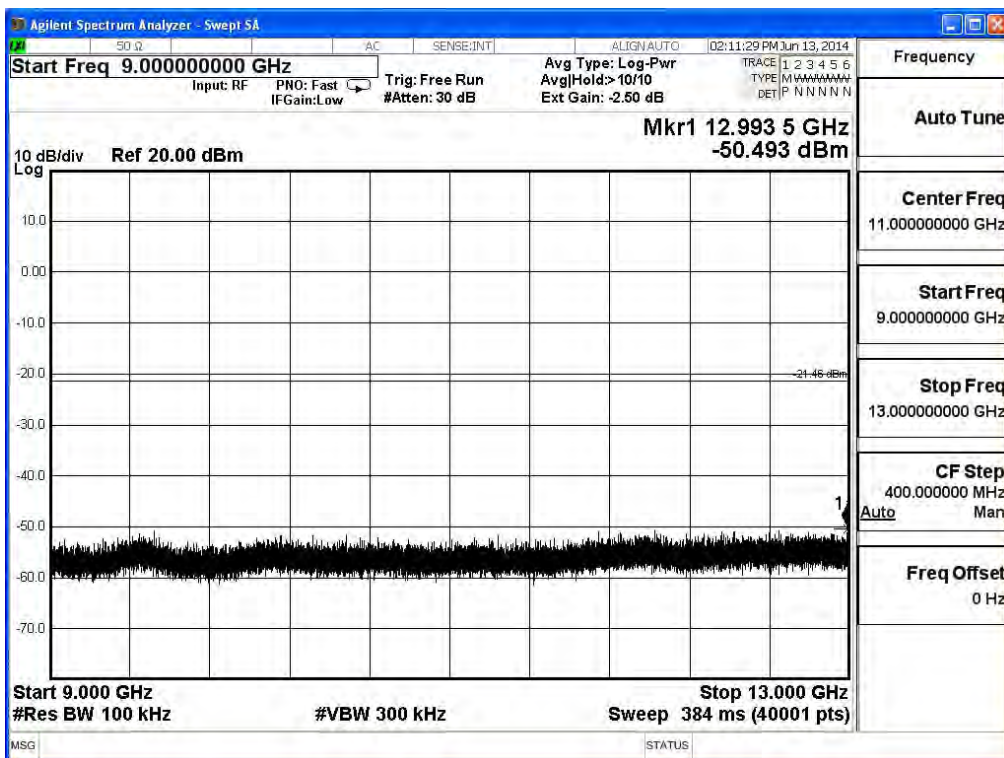

Product	SkyCaddie		
Test Item	RF antenna conducted test		
Test Mode	Mode 1: Transmit (Power by PC)		
Date of Test	2014/02/17	Test Site	SR7

Channel 78 (13GHz-17GHz)- 8-DQPSK

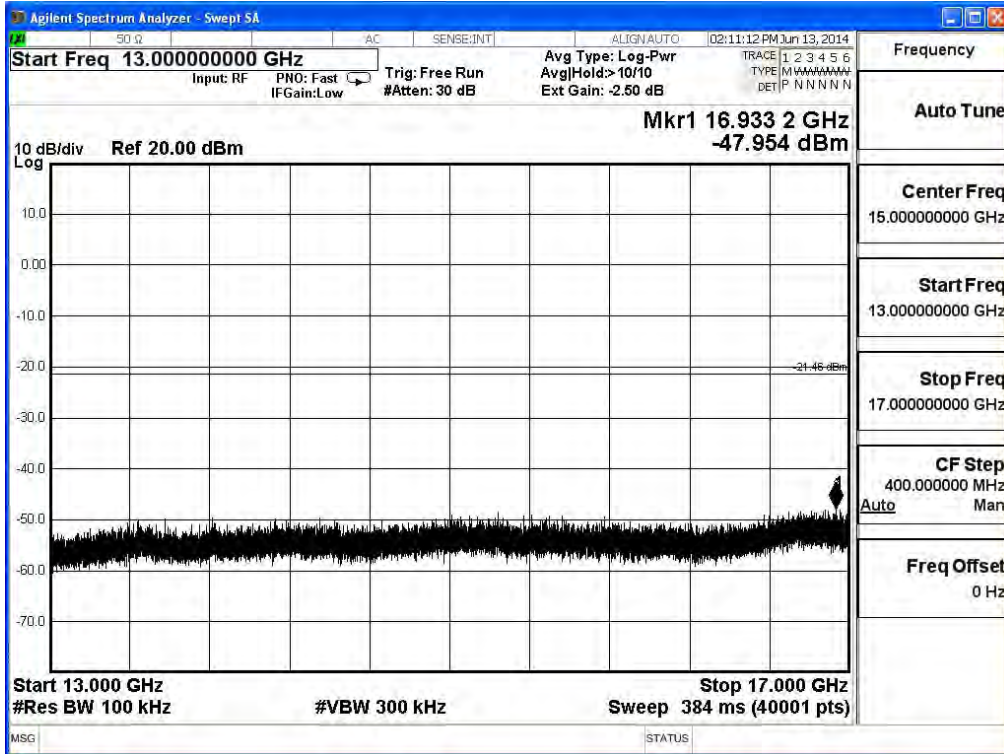

Channel 78 (17GHz~21GHz)- 8-DQPSK

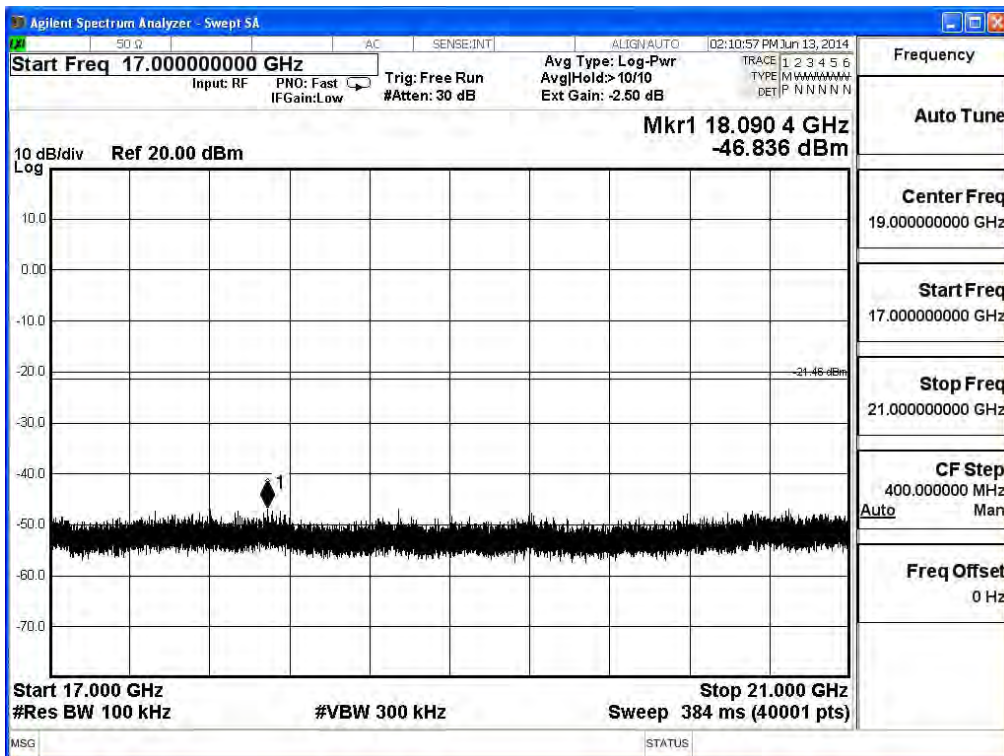

Product	SkyCaddie		
Test Item	RF antenna conducted test		
Test Mode	Mode 1: Transmit (Power by PC)		
Date of Test	2014/02/17	Test Site	SR7

Channel 78 (21GHz-25GHz)- 8-DQPSK

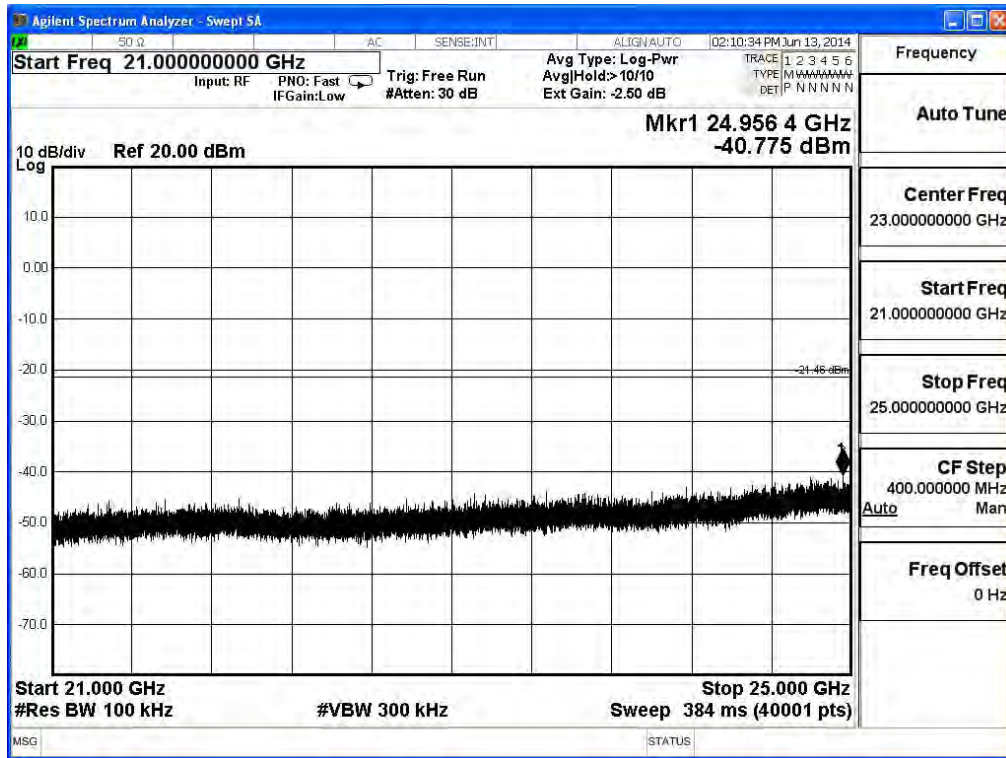

6. Band Edge

6.1. Test Equipment

The following test equipments are used during the test:

Band Edge / CB1

Instrument	Manufacturer	Model No.	Serial No	Next Cal. Date
Double Ridged Guide Horn Antenna	Schwarzback	BBHA 9120	D743	2015/02/12
Spectrum Analyzer	Agilent	E4440A	MY46187335	2015/01/12
k Type Cable	Huber Suhner	Sucoflex 102	25623/2	2015/02/10

Note: 1. All equipments that need to calibrate are with calibration period of 1 year.

6.2. Test Setup

RF Radiated Measurement:

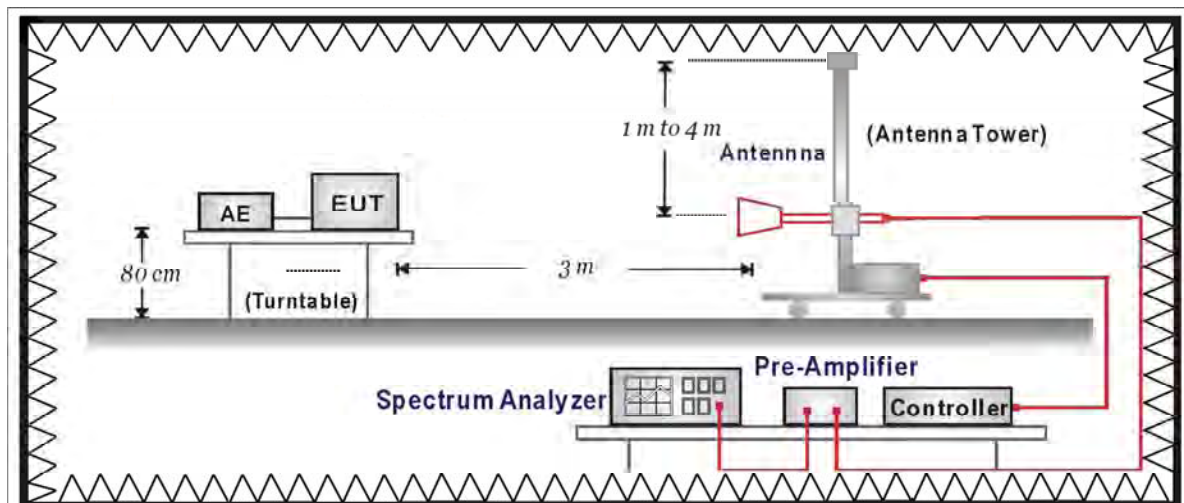

6.3. Limits

Emissions radiated outside of the specified frequency bands, except for harmonics, shall be attenuated by at least 20dB below the level of the fundamental or to the general radiated emission limits in paragraph 15.209, whichever is the lesser attenuation.

6.4. Test Procedure

The EUT was setup according to ANSI C63.10 and tested according to FHSS test procedure of FCC Public Notice DA 00-705 for compliance to FCC 47CFR 15.247 requirements

The EUT and its simulators are placed on a turn table which is 0.8 meter above ground.

The turn table can rotate 360 degrees to determine the position of the maximum emission level. The EUT was positioned such that the distance from antenna to the EUT was 3 meters.

The antenna can move up and down between 1 meter and 4 meters to find out the maximum emission level.

Both horizontal and vertical polarization of the antenna are set on measurement. In order to find the maximum emission, all of the interface cables must be manipulated according to ANSI C63.10 on radiated measurement.

6.5. Test Specification

According to FCC Part 15 Subpart C Paragraph 15.247: 2013

6.6. Test Result

Site : CB1	Time : 2014/09/25 - 16:26
Limit : FCC_SpartC_15.249_H_03M_PK	Margin : 6
Probe : CB1_FCC_EFS_1-18G-1_0901 - HORIZONTAL	Power : AC 120V / 60Hz
EUT : SkyCaddie	Note : Mode 1: Transmit (Power by PC)_2402MHz

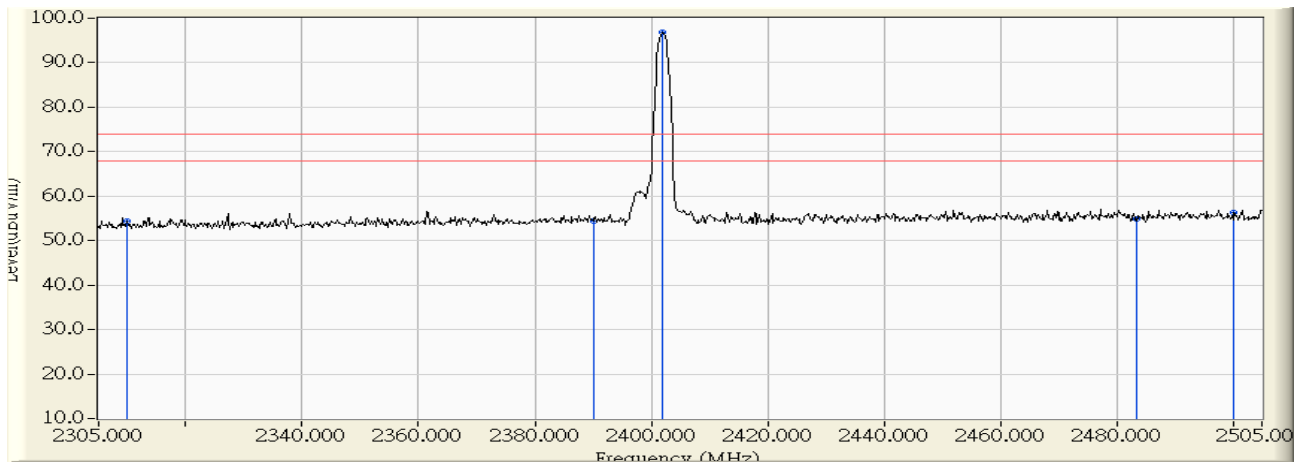

	Frequency (MHz)	Correct Factor (dB)	Reading Level (dBuV)	Measure Level (dBuV/m)	Margin (dB)	Limit (dBuV/m)	Detector Type
1	2310.000	30.411	24.056	54.467	-19.503	73.970	PEAK
2	2390.000	31.241	23.059	54.300	-19.670	73.970	PEAK
3	* 2402.000	31.365	65.387	96.752	22.782	73.970	PEAK
4	2483.500	31.980	22.977	54.956	-19.014	73.970	PEAK
5	2500.000	31.934	24.351	56.286	-17.684	73.970	PEAK

Note:

1. All readings above 1GHz are performed with peak and/or average measurements as necessary.
2. Peak measurements: RBW = 1MHz, VBW = 1MHz, Sweep: Auto.
3. Average measurements: RBW = 1MHz, VBW = 10 Hz, Sweep: Auto.
4. “ * ”, means this data is the worst emission level.
5. Measurement Level = Reading Level + Correct Factor.
6. The average measurement was not performed when the peak measured data under the limit of average detection. If the readings given are average, peak measurement should also be supplied.

Site : CB1	Time : 2014/09/25 - 16:27
Limit : FCC_SpartC_15.249_H_03M_AV	Margin : 6
Probe : CB1_FCC_EFS_1-18G-1_0901 - HORIZONTAL	Power : AC 120V / 60Hz
EUT : SkyCaddie	Note : Mode 1: Transmit (Power by PC)_2402MHz

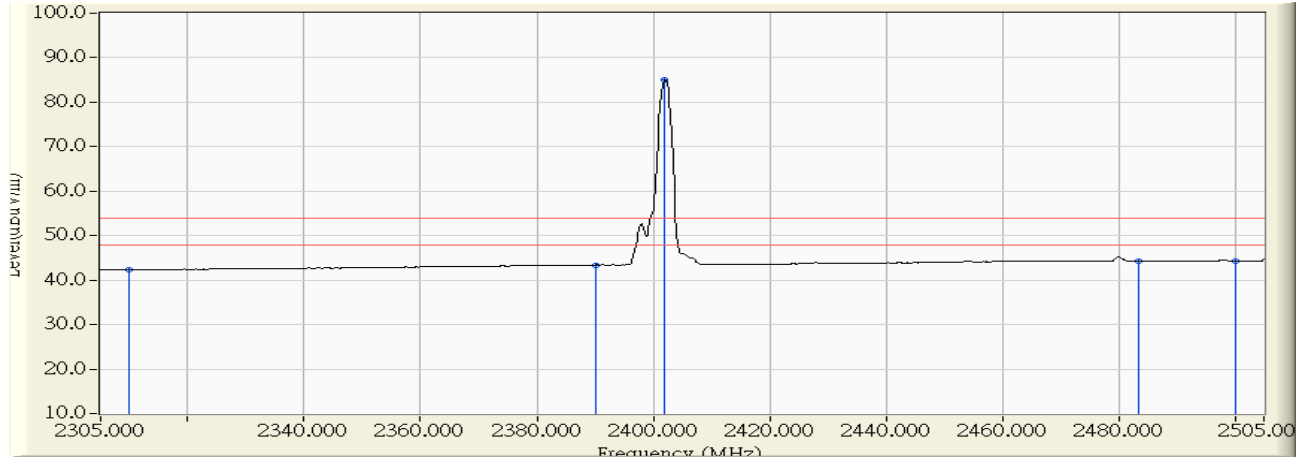

	Frequency (MHz)	Correct Factor (dB)	Reading Level (dBuV)	Measure Level (dBuV/m)	Margin (dB)	Limit (dBuV/m)	Detector Type
1	2310.000	30.411	11.909	42.320	-11.650	53.970	AVERAGE
2	2390.000	31.241	12.133	43.374	-10.596	53.970	AVERAGE
3	* 2402.000	31.365	53.715	85.080	31.110	53.970	AVERAGE
4	2483.500	31.980	12.307	44.286	-9.684	53.970	AVERAGE
5	2500.000	31.934	12.334	44.269	-9.701	53.970	AVERAGE

Note:

1. All readings above 1GHz are performed with peak and/or average measurements as necessary.
2. Peak measurements: RBW = 1MHz, VBW = 1MHz, Sweep: Auto.
3. Average measurements: RBW = 1MHz, VBW = 10 Hz, Sweep: Auto.
4. “ * ”, means this data is the worst emission level.
5. Measurement Level = Reading Level + Correct Factor.
6. The average measurement was not performed when the peak measured data under the limit of average detection. If the readings given are average, peak measurement should also be supplied.

Site : CB1	Time : 2014/09/25 - 16:30
Limit : FCC_SpartC_15.249_H_03M_PK	Margin : 6
Probe : CB1_FCC_EFS_1-18G-1_0901 - VERTICAL	Power : AC 120V / 60Hz
EUT : SkyCaddie	Note : Mode 1: Transmit (Power by PC)_2402MHz

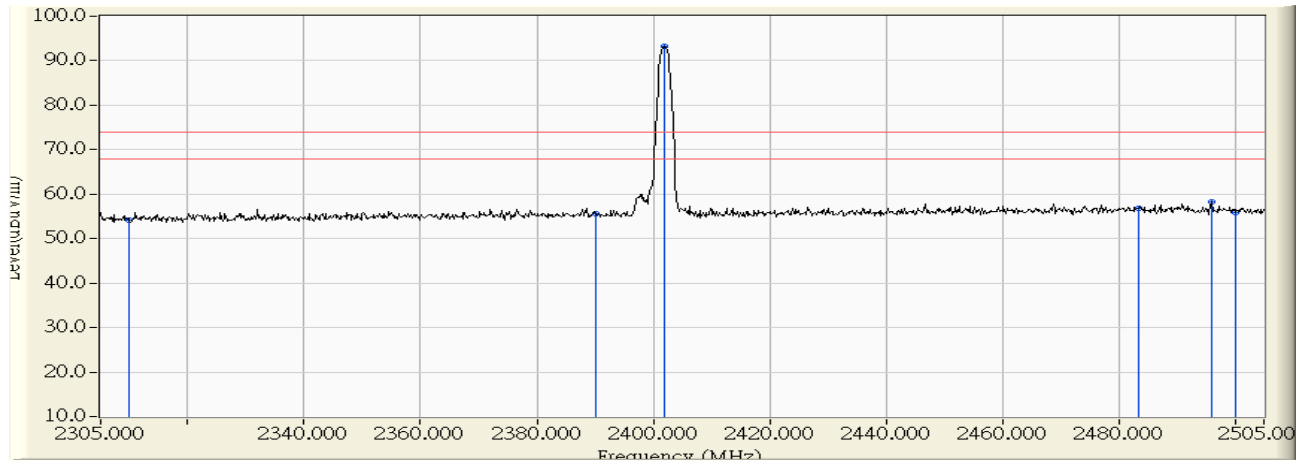

	Frequency (MHz)	Correct Factor (dB)	Reading Level (dBuV)	Measure Level (dBuV/m)	Margin (dB)	Limit (dBuV/m)	Detector Type
1	2310.000	30.411	23.745	54.156	-19.814	73.970	PEAK
2	2390.000	31.241	24.276	55.517	-18.453	73.970	PEAK
3	* 2401.800	31.363	61.857	93.220	19.250	73.970	PEAK
4	2483.500	31.980	24.883	56.862	-17.108	73.970	PEAK
5	2496.000	31.946	26.209	58.155	-15.815	73.970	PEAK
6	2500.000	31.934	23.972	55.907	-18.063	73.970	PEAK

Note:

1. All readings above 1GHz are performed with peak and/or average measurements as necessary.
2. Peak measurements: RBW = 1MHz, VBW = 1MHz, Sweep: Auto.
3. Average measurements: RBW = 1MHz, VBW = 10 Hz, Sweep: Auto.
4. “ * ”, means this data is the worst emission level.
5. Measurement Level = Reading Level + Correct Factor.
6. The average measurement was not performed when the peak measured data under the limit of average detection. If the readings given are average, peak measurement should also be supplied.

Site : CB1	Time : 2014/09/25 - 16:31
Limit : FCC_SpartC_15.249_H_03M_AV	Margin : 6
Probe : CB1_FCC_EFS_1-18G-1_0901 - VERTICAL	Power : AC 120V / 60Hz
EUT : SkyCaddie	Note : Mode 1: Transmit (Power by PC)_2402MHz

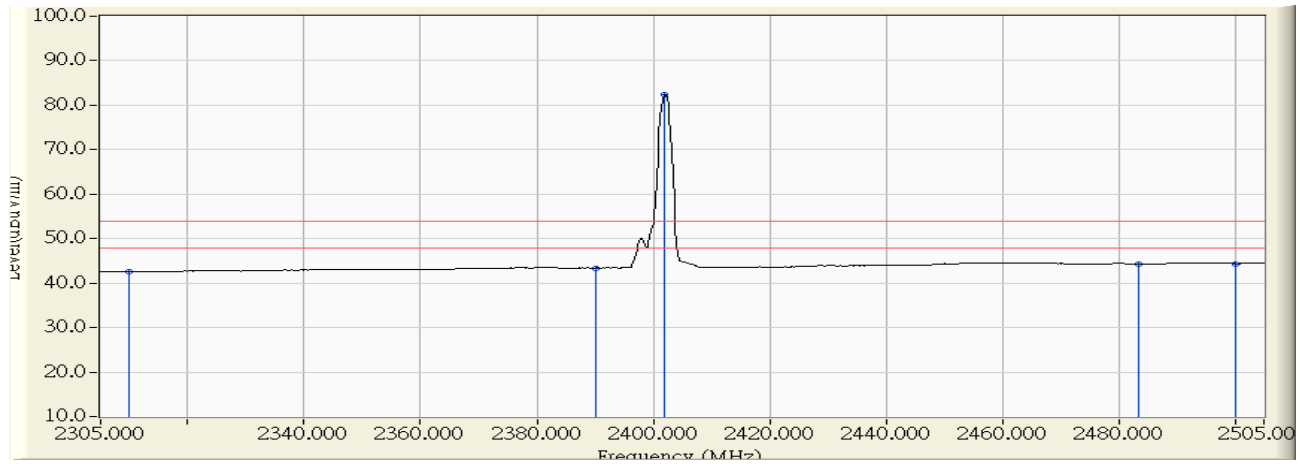

	Frequency (MHz)	Correct Factor (dB)	Reading Level (dBuV)	Measure Level (dBuV/m)	Margin (dB)	Limit (dBuV/m)	Detector Type
1	2310.000	30.411	12.131	42.542	-11.428	53.970	AVERAGE
2	2390.000	31.241	12.144	43.385	-10.585	53.970	AVERAGE
3	* 2402.000	31.365	51.052	82.417	28.447	53.970	AVERAGE
4	2483.500	31.980	12.362	44.341	-9.629	53.970	AVERAGE
5	2500.000	31.934	12.433	44.368	-9.602	53.970	AVERAGE

Note:

1. All readings above 1GHz are performed with peak and/or average measurements as necessary.
2. Peak measurements: RBW = 1MHz, VBW = 1MHz, Sweep: Auto.
3. Average measurements: RBW = 1MHz, VBW = 10 Hz, Sweep: Auto.
4. “ * ”, means this data is the worst emission level.
5. Measurement Level = Reading Level + Correct Factor.
6. The average measurement was not performed when the peak measured data under the limit of average detection. If the readings given are average, peak measurement should also be supplied.

Site : CB1	Time : 2014/09/25 - 17:03
Limit : FCC_SpartC_15.249_H_03M_PK	Margin : 6
Probe : CB1_FCC_EFS_1-18G-1_0901 - HORIZONTAL	Power : AC 120V / 60Hz
EUT : SkyCaddie	Note : Mode 1: Transmit (Power by PC)_2480MHz

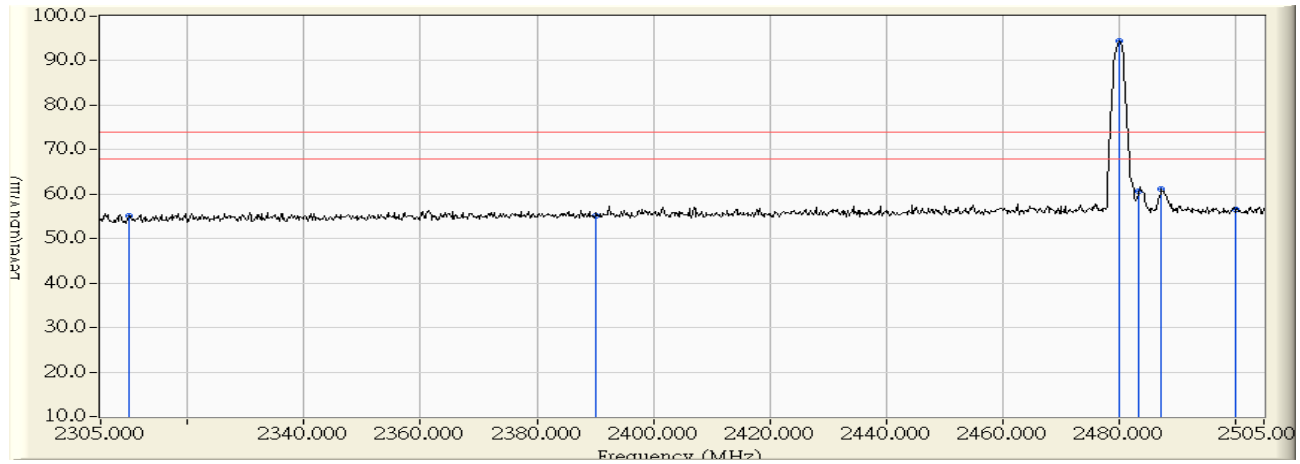

	Frequency (MHz)	Correct Factor (dB)	Reading Level (dBuV)	Measure Level (dBuV/m)	Margin (dB)	Limit (dBuV/m)	Detector Type
1	2310.000	30.411	24.640	55.051	-18.919	73.970	PEAK
2	2390.000	31.241	23.785	55.026	-18.944	73.970	PEAK
3	* 2480.200	31.989	62.428	94.416	20.446	73.970	PEAK
4	2483.500	31.980	28.758	60.737	-13.233	73.970	PEAK
5	2487.400	31.969	29.262	61.231	-12.739	73.970	PEAK
6	2500.000	31.934	24.640	56.575	-17.395	73.970	PEAK

Note:

1. All readings above 1GHz are performed with peak and/or average measurements as necessary.
2. Peak measurements: RBW = 1MHz, VBW = 1MHz, Sweep: Auto.
3. Average measurements: RBW = 1MHz, VBW = 10 Hz, Sweep: Auto.
4. “ * ”, means this data is the worst emission level.
5. Measurement Level = Reading Level + Correct Factor.
6. The average measurement was not performed when the peak measured data under the limit of average detection. If the readings given are average, peak measurement should also be supplied.

Site : CB1	Time : 2014/09/25 - 17:04
Limit : FCC_SpartC_15.249_H_03M_AV	Margin : 6
Probe : CB1_FCC_EFS_1-18G-1_0901 - HORIZONTAL	Power : AC 120V / 60Hz
EUT : SkyCaddie	Note : Mode 1: Transmit (Power by PC)_2480MHz

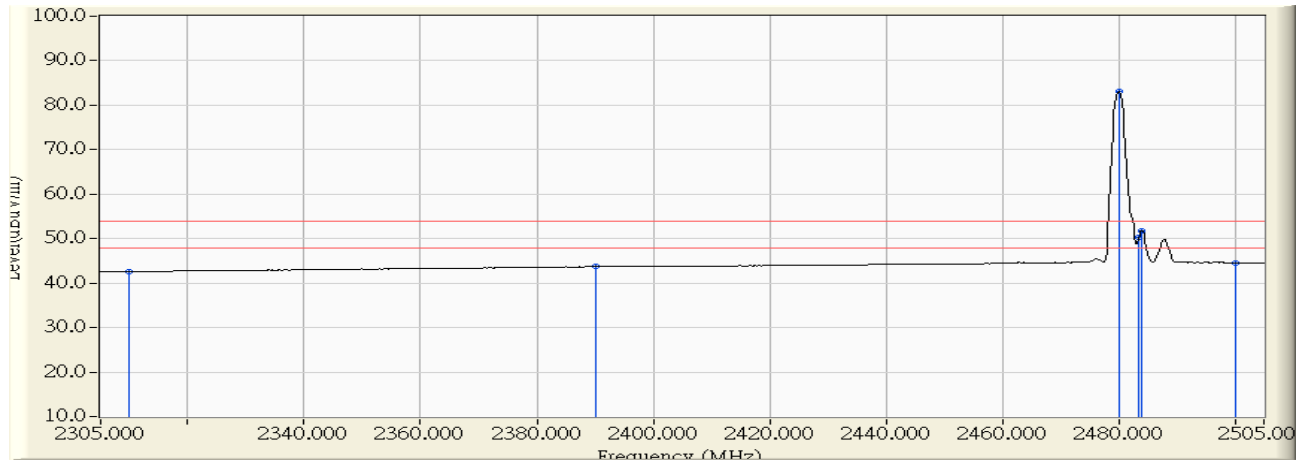

	Frequency (MHz)	Correct Factor (dB)	Reading Level (dBuV)	Measure Level (dBuV/m)	Margin (dB)	Limit (dBuV/m)	Detector Type
1	2310.000	30.411	12.214	42.625	-11.345	53.970	AVERAGE
2	2390.000	31.241	12.473	43.714	-10.256	53.970	AVERAGE
3	* 2480.000	31.989	51.204	83.193	29.223	53.970	AVERAGE
4	2483.500	31.980	18.398	50.377	-3.593	53.970	AVERAGE
5	2484.000	31.978	19.877	51.855	-2.115	53.970	AVERAGE
6	2500.000	31.934	12.655	44.590	-9.380	53.970	AVERAGE

Note:

1. All readings above 1GHz are performed with peak and/or average measurements as necessary.
2. Peak measurements: RBW = 1MHz, VBW = 1MHz, Sweep: Auto.
3. Average measurements: RBW = 1MHz, VBW = 10 Hz, Sweep: Auto.
4. “ * ”, means this data is the worst emission level.
5. Measurement Level = Reading Level + Correct Factor.
6. The average measurement was not performed when the peak measured data under the limit of average detection. If the readings given are average, peak measurement should also be supplied.

Site : CB1	Time : 2014/09/25 - 17:08
Limit : FCC_SpartC_15.249_H_03M_PK	Margin : 6
Probe : CB1_FCC_EFS_1-18G-1_0901 - VERTICAL	Power : AC 120V / 60Hz
EUT : SkyCaddie	Note : Mode 1: Transmit (Power by PC)_2480MHz

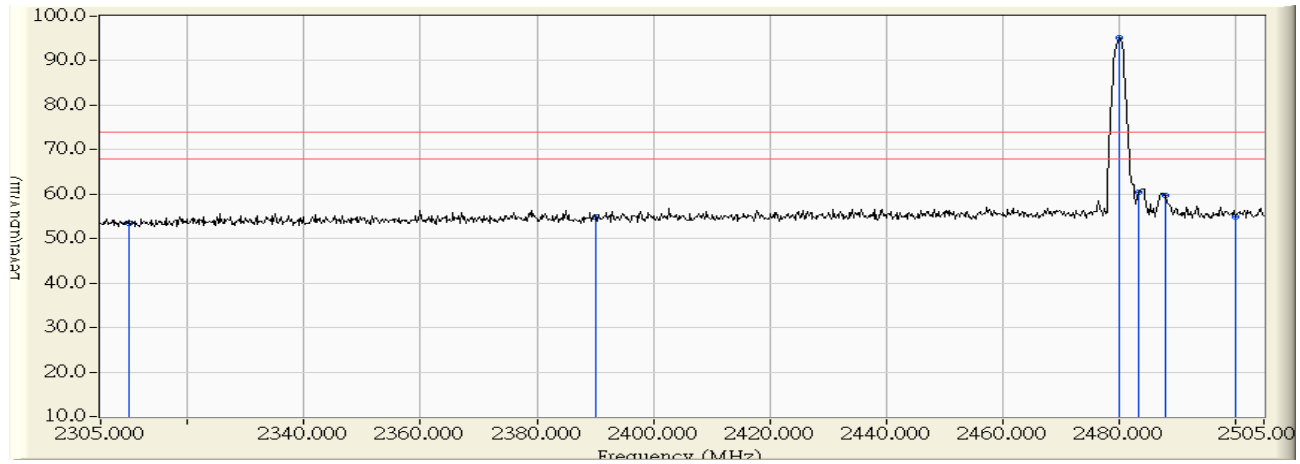

	Frequency (MHz)	Correct Factor (dB)	Reading Level (dBuV)	Measure Level (dBuV/m)	Margin (dB)	Limit (dBuV/m)	Detector Type
1	2310.000	30.411	23.046	53.457	-20.513	73.970	PEAK
2	2390.000	31.241	23.689	54.930	-19.040	73.970	PEAK
3	* 2480.200	31.989	63.148	95.136	21.166	73.970	PEAK
4	2483.500	31.980	28.349	60.328	-13.642	73.970	PEAK
5	2488.200	31.967	27.793	59.760	-14.210	73.970	PEAK
6	2500.000	31.934	22.867	54.802	-19.168	73.970	PEAK

Note:

1. All readings above 1GHz are performed with peak and/or average measurements as necessary.
2. Peak measurements: RBW = 1MHz, VBW = 1MHz, Sweep: Auto.
3. Average measurements: RBW = 1MHz, VBW = 10 Hz, Sweep: Auto.
4. “ * ”, means this data is the worst emission level.
5. Measurement Level = Reading Level + Correct Factor.
6. The average measurement was not performed when the peak measured data under the limit of average detection. If the readings given are average, peak measurement should also be supplied.

Site : CB1	Time : 2014/09/25 - 17:08
Limit : FCC_SpartC_15.249_H_03M_AV	Margin : 6
Probe : CB1_FCC_EFS_1-18G-1_0901 - VERTICAL	Power : AC 120V / 60Hz
EUT : SkyCaddie	Note : Mode 1: Transmit (Power by PC)_2480MHz

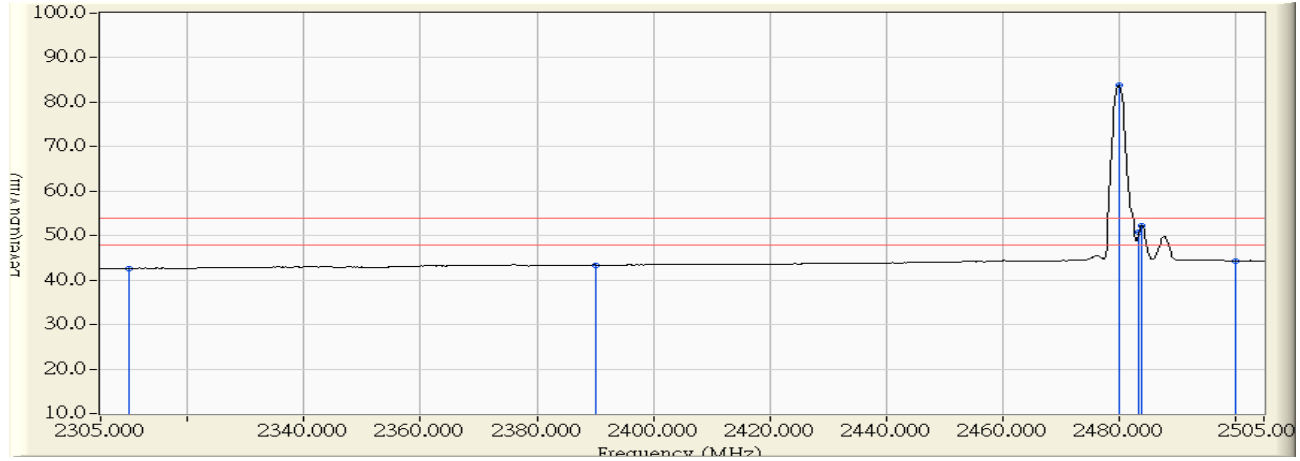

	Frequency (MHz)	Correct Factor (dB)	Reading Level (dBuV)	Measure Level (dBuV/m)	Margin (dB)	Limit (dBuV/m)	Detector Type
1	2310.000	30.411	12.237	42.648	-11.322	53.970	AVERAGE
2	2390.000	31.241	12.139	43.380	-10.590	53.970	AVERAGE
3	* 2480.000	31.989	51.824	83.813	29.843	53.970	AVERAGE
4	2483.500	31.980	18.844	50.823	-3.147	53.970	AVERAGE
5	2484.000	31.978	20.250	52.228	-1.742	53.970	AVERAGE
6	2500.000	31.934	12.387	44.322	-9.648	53.970	AVERAGE

Note:

1. All readings above 1GHz are performed with peak and/or average measurements as necessary.
2. Peak measurements: RBW = 1MHz, VBW = 1MHz, Sweep: Auto.
3. Average measurements: RBW = 1MHz, VBW = 10 Hz, Sweep: Auto.
4. “ * ”, means this data is the worst emission level.
5. Measurement Level = Reading Level + Correct Factor.
6. The average measurement was not performed when the peak measured data under the limit of average detection. If the readings given are average, peak measurement should also be supplied.

Site : CB1	Time : 2014/09/25 - 17:12
Limit : FCC_SpartC_15.249_H_03M_PK	Margin : 6
Probe : CB1_FCC_EFS_1-18G-1_0901 - HORIZONTAL	Power : AC 120V / 60Hz
EUT : SkyCaddie	Note : Mode 1: Transmit (Power by PC)_ 2402MHz

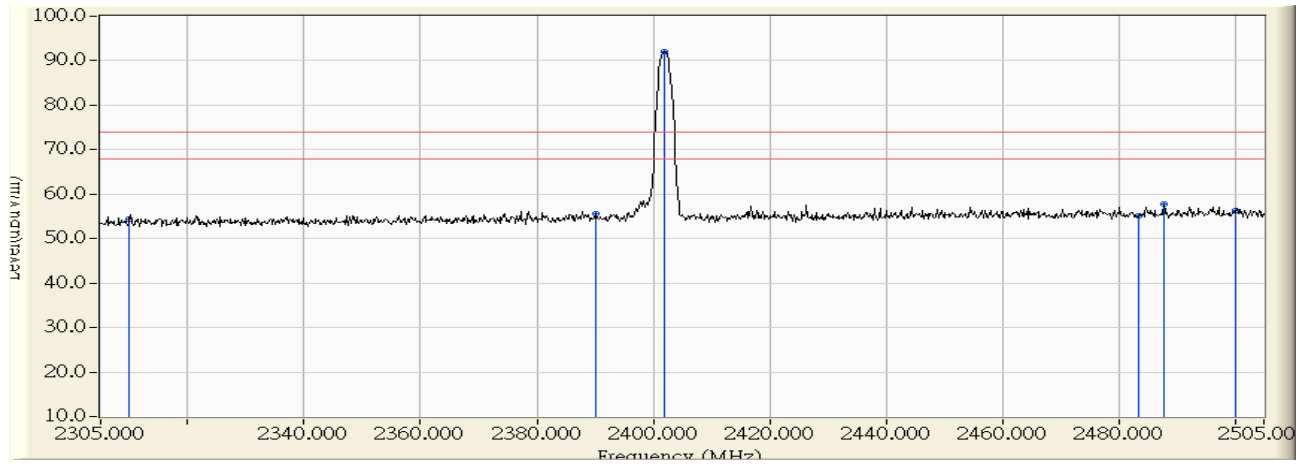

	Frequency (MHz)	Correct Factor (dB)	Reading Level (dBuV)	Measure Level (dBuV/m)	Margin (dB)	Limit (dBuV/m)	Detector Type
1	2310.000	30.411	23.986	54.397	-19.573	73.970	PEAK
2	2390.000	31.241	24.476	55.717	-18.253	73.970	PEAK
3	* 2402.000	31.365	60.753	92.118	18.148	73.970	PEAK
4	2483.500	31.980	23.253	55.232	-18.738	73.970	PEAK
5	2487.800	31.968	25.866	57.834	-16.136	73.970	PEAK
6	2500.000	31.934	24.480	56.415	-17.555	73.970	PEAK

Note:

1. All readings above 1GHz are performed with peak and/or average measurements as necessary.
2. Peak measurements: RBW = 1MHz, VBW = 1MHz, Sweep: Auto.
3. Average measurements: RBW = 1MHz, VBW = 10 Hz, Sweep: Auto.
4. “ * ”, means this data is the worst emission level.
5. Measurement Level = Reading Level + Correct Factor.
6. The average measurement was not performed when the peak measured data under the limit of average detection. If the readings given are average, peak measurement should also be supplied.

Site : CB1	Time : 2014/09/25 - 17:12
Limit : FCC_SpartC_15.249_H_03M_AV	Margin : 6
Probe : CB1_FCC_EFS_1-18G-1_0901 - HORIZONTAL	Power : AC 120V / 60Hz
EUT : SkyCaddie	Note : Mode 1: Transmit (Power by PC)_ 2402MHz

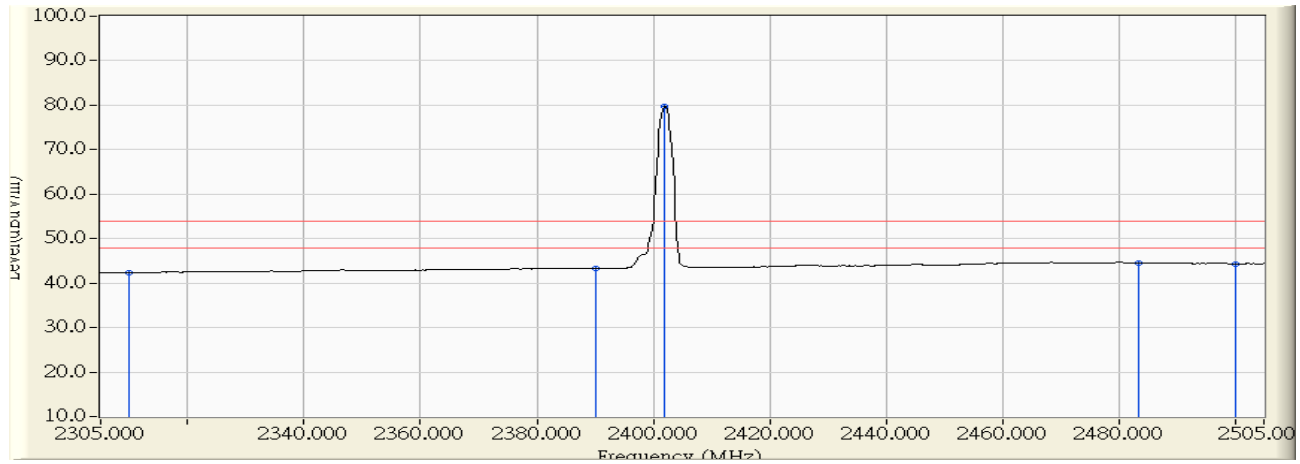

	Frequency (MHz)	Correct Factor (dB)	Reading Level (dBuV)	Measure Level (dBuV/m)	Margin (dB)	Limit (dBuV/m)	Detector Type
1	2310.000	30.411	11.934	42.345	-11.625	53.970	AVERAGE
2	2390.000	31.241	12.153	43.394	-10.576	53.970	AVERAGE
3	* 2402.000	31.365	48.311	79.676	25.706	53.970	AVERAGE
4	2483.500	31.980	12.438	44.417	-9.553	53.970	AVERAGE
5	2500.000	31.934	12.412	44.347	-9.623	53.970	AVERAGE

Note:

1. All readings above 1GHz are performed with peak and/or average measurements as necessary.
2. Peak measurements: RBW = 1MHz, VBW = 1MHz, Sweep: Auto.
3. Average measurements: RBW = 1MHz, VBW = 10 Hz, Sweep: Auto.
4. “ * ”, means this data is the worst emission level.
5. Measurement Level = Reading Level + Correct Factor.
6. The average measurement was not performed when the peak measured data under the limit of average detection. If the readings given are average, peak measurement should also be supplied.

Site : CB1	Time : 2014/09/25 - 17:15
Limit : FCC_SpartC_15.249_H_03M_PK	Margin : 6
Probe : CB1_FCC_EFS_1-18G-1_0901 - VERTICAL	Power : AC 120V / 60Hz
EUT : SkyCaddie	Note : Mode 1: Transmit (Power by PC)_ 2402MHz

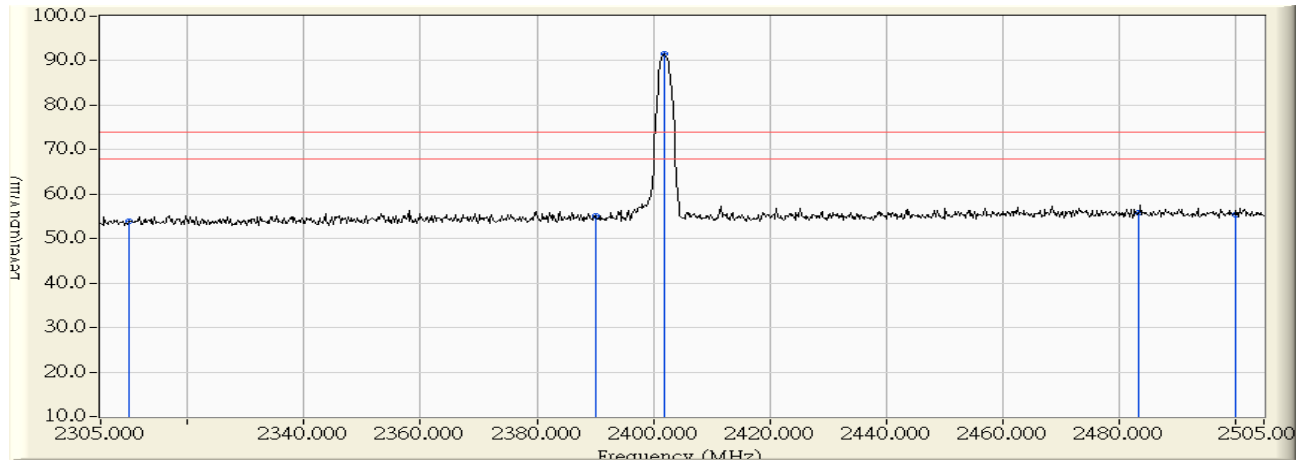

	Frequency (MHz)	Correct Factor (dB)	Reading Level (dBuV)	Measure Level (dBuV/m)	Margin (dB)	Limit (dBuV/m)	Detector Type
1	2310.000	30.411	23.505	53.916	-20.054	73.970	PEAK
2	2390.000	31.241	23.789	55.030	-18.940	73.970	PEAK
3	* 2401.800	31.363	60.161	91.524	17.554	73.970	PEAK
4	2483.500	31.980	23.983	55.962	-18.008	73.970	PEAK
5	2500.000	31.934	23.332	55.267	-18.703	73.970	PEAK

Note:

1. All readings above 1GHz are performed with peak and/or average measurements as necessary.
2. Peak measurements: RBW = 1MHz, VBW = 1MHz, Sweep: Auto.
3. Average measurements: RBW = 1MHz, VBW = 10 Hz, Sweep: Auto.
4. “ * ”, means this data is the worst emission level.
5. Measurement Level = Reading Level + Correct Factor.
6. The average measurement was not performed when the peak measured data under the limit of average detection. If the readings given are average, peak measurement should also be supplied.

Site : CB1	Time : 2014/09/25 - 17:15
Limit : FCC_SpartC_15.249_H_03M_AV	Margin : 6
Probe : CB1_FCC_EFS_1-18G-1_0901 - VERTICAL	Power : AC 120V / 60Hz
EUT : SkyCaddie	Note : Mode 1: Transmit (Power by PC)_ 2402MHz

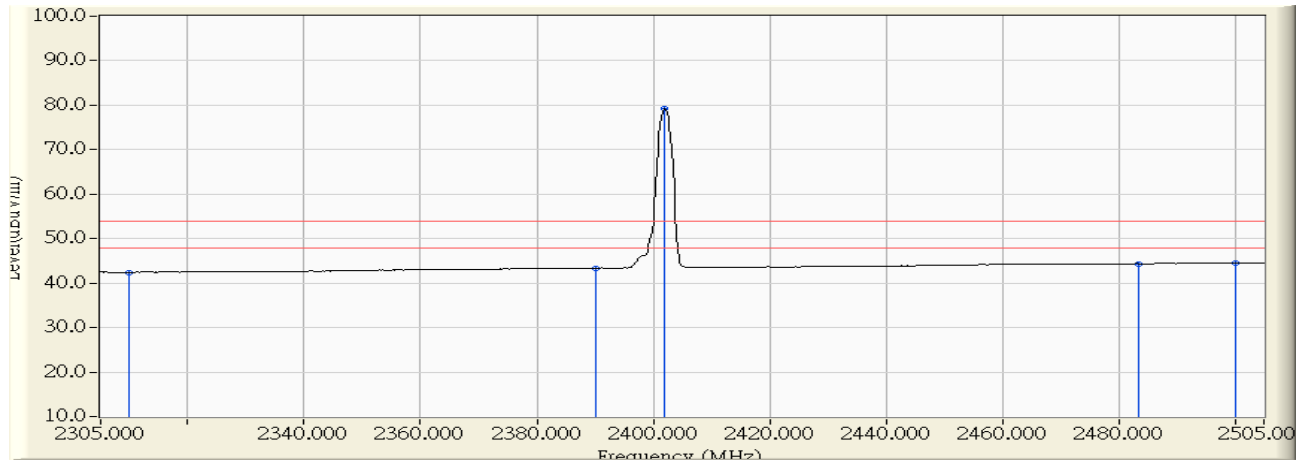

	Frequency (MHz)	Correct Factor (dB)	Reading Level (dBuV)	Measure Level (dBuV/m)	Margin (dB)	Limit (dBuV/m)	Detector Type
1	2310.000	30.411	11.998	42.409	-11.561	53.970	AVERAGE
2	2390.000	31.241	12.122	43.363	-10.607	53.970	AVERAGE
3	* 2402.000	31.365	47.868	79.233	25.263	53.970	AVERAGE
4	2483.500	31.980	12.386	44.365	-9.605	53.970	AVERAGE
5	2500.000	31.934	12.521	44.456	-9.514	53.970	AVERAGE

Note:

1. All readings above 1GHz are performed with peak and/or average measurements as necessary.
2. Peak measurements: RBW = 1MHz, VBW = 1MHz, Sweep: Auto.
3. Average measurements: RBW = 1MHz, VBW = 10 Hz, Sweep: Auto.
4. “ * ”, means this data is the worst emission level.
5. Measurement Level = Reading Level + Correct Factor.
6. The average measurement was not performed when the peak measured data under the limit of average detection. If the readings given are average, peak measurement should also be supplied.

Site : CB1	Time : 2014/09/25 - 17:18
Limit : FCC_SpartC_15.249_H_03M_PK	Margin : 6
Probe : CB1_FCC_EFS_1-18G-1_0901 - HORIZONTAL	Power : AC 120V / 60Hz
EUT : SkyCaddie	Note : Mode 1: Transmit (Power by PC)_ 2480MHz

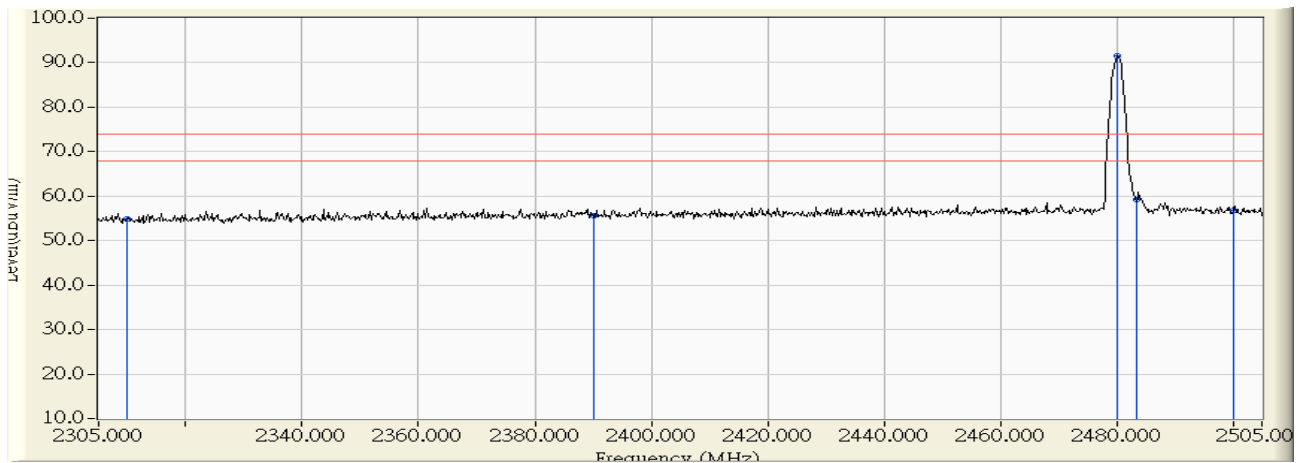

	Frequency (MHz)	Correct Factor (dB)	Reading Level (dBuV)	Measure Level (dBuV/m)	Margin (dB)	Limit (dBuV/m)	Detector Type
1	2310.000	30.411	24.351	54.762	-19.208	73.970	PEAK
2	2390.000	31.241	24.353	55.594	-18.376	73.970	PEAK
3	* 2480.200	31.989	59.533	91.521	17.551	73.970	PEAK
4	2483.500	31.980	27.225	59.204	-14.766	73.970	PEAK
5	2500.000	31.934	24.816	56.751	-17.219	73.970	PEAK

Note:

1. All readings above 1GHz are performed with peak and/or average measurements as necessary.
2. Peak measurements: RBW = 1MHz, VBW = 1MHz, Sweep: Auto.
3. Average measurements: RBW = 1MHz, VBW = 10 Hz, Sweep: Auto.
4. “ * ”, means this data is the worst emission level.
5. Measurement Level = Reading Level + Correct Factor.
6. The average measurement was not performed when the peak measured data under the limit of average detection. If the readings given are average, peak measurement should also be supplied.

Site : CB1	Time : 2014/09/25 - 17:19
Limit : FCC_SpartC_15.249_H_03M_AV	Margin : 6
Probe : CB1_FCC_EFS_1-18G-1_0901 - HORIZONTAL	Power : AC 120V / 60Hz
EUT : SkyCaddie	Note : Mode 1: Transmit (Power by PC)_ 2480MHz

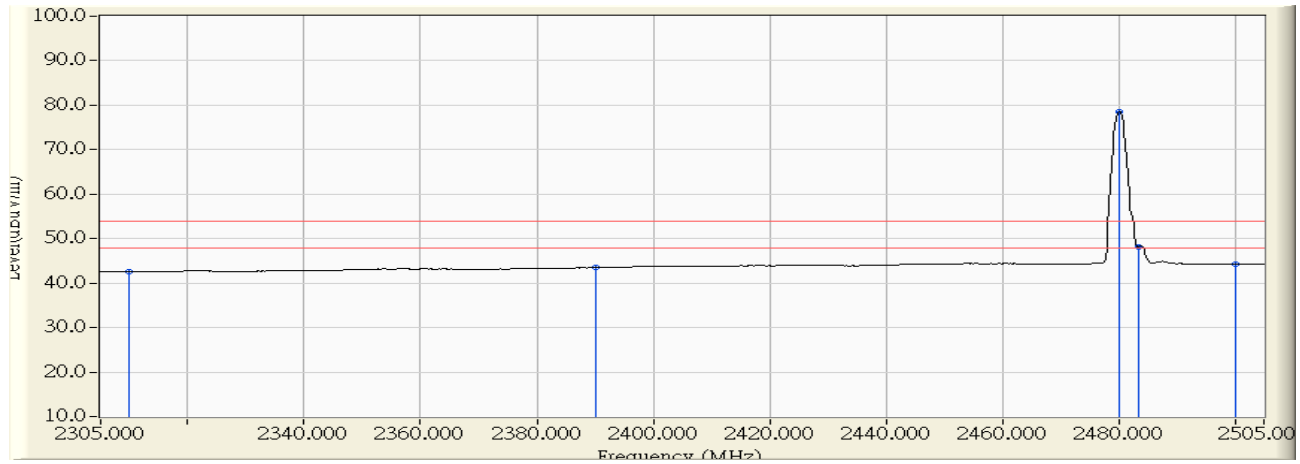

	Frequency (MHz)	Correct Factor (dB)	Reading Level (dBuV)	Measure Level (dBuV/m)	Margin (dB)	Limit (dBuV/m)	Detector Type
1	2310.000	30.411	12.151	42.562	-11.408	53.970	AVERAGE
2	2390.000	31.241	12.257	43.498	-10.472	53.970	AVERAGE
3	* 2480.200	31.989	46.656	78.644	24.674	53.970	AVERAGE
4	2483.500	31.980	16.237	48.216	-5.754	53.970	AVERAGE
5	2500.000	31.934	12.376	44.311	-9.659	53.970	AVERAGE

Note:

1. All readings above 1GHz are performed with peak and/or average measurements as necessary.
2. Peak measurements: RBW = 1MHz, VBW = 1MHz, Sweep: Auto.
3. Average measurements: RBW = 1MHz, VBW = 10 Hz, Sweep: Auto.
4. “ * ”, means this data is the worst emission level.
5. Measurement Level = Reading Level + Correct Factor.
6. The average measurement was not performed when the peak measured data under the limit of average detection. If the readings given are average, peak measurement should also be supplied.

Site : CB1	Time : 2014/09/25 - 17:22
Limit : FCC_SpartC_15.249_H_03M_PK	Margin : 6
Probe : CB1_FCC_EFS_1-18G-1_0901 - VERTICAL	Power : AC 120V / 60Hz
EUT : SkyCaddie	Note : Mode 1: Transmit (Power by PC)_ 2480MHz

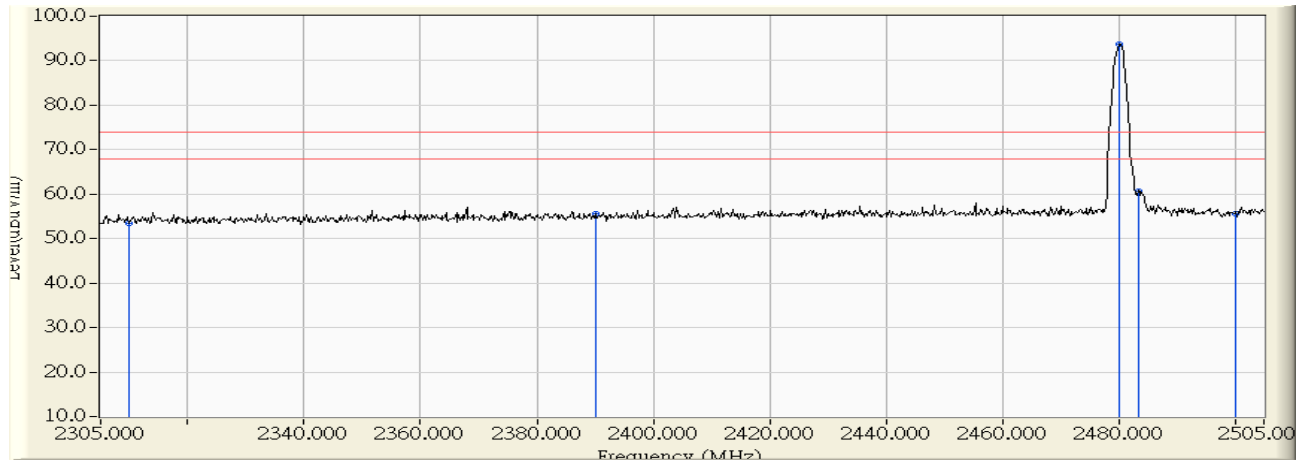

	Frequency (MHz)	Correct Factor (dB)	Reading Level (dBuV)	Measure Level (dBuV/m)	Margin (dB)	Limit (dBuV/m)	Detector Type
1	2310.000	30.411	22.993	53.404	-20.566	73.970	PEAK
2	2390.000	31.241	24.361	55.602	-18.368	73.970	PEAK
3	* 2480.200	31.989	61.690	93.678	19.708	73.970	PEAK
4	2483.500	31.980	28.802	60.781	-13.189	73.970	PEAK
5	2500.000	31.934	23.590	55.525	-18.445	73.970	PEAK

Note:

1. All readings above 1GHz are performed with peak and/or average measurements as necessary.
2. Peak measurements: RBW = 1MHz, VBW = 1MHz, Sweep: Auto.
3. Average measurements: RBW = 1MHz, VBW = 10 Hz, Sweep: Auto.
4. “ * ”, means this data is the worst emission level.
5. Measurement Level = Reading Level + Correct Factor.
6. The average measurement was not performed when the peak measured data under the limit of average detection. If the readings given are average, peak measurement should also be supplied.

Site : CB1	Time : 2014/09/25 - 17:23
Limit : FCC_SpartC_15.249_H_03M_AV	Margin : 6
Probe : CB1_FCC_EFS_1-18G-1_0901 - VERTICAL	Power : AC 120V / 60Hz
EUT : SkyCaddie	Note : Mode 1: Transmit (Power by PC)_ 2480MHz

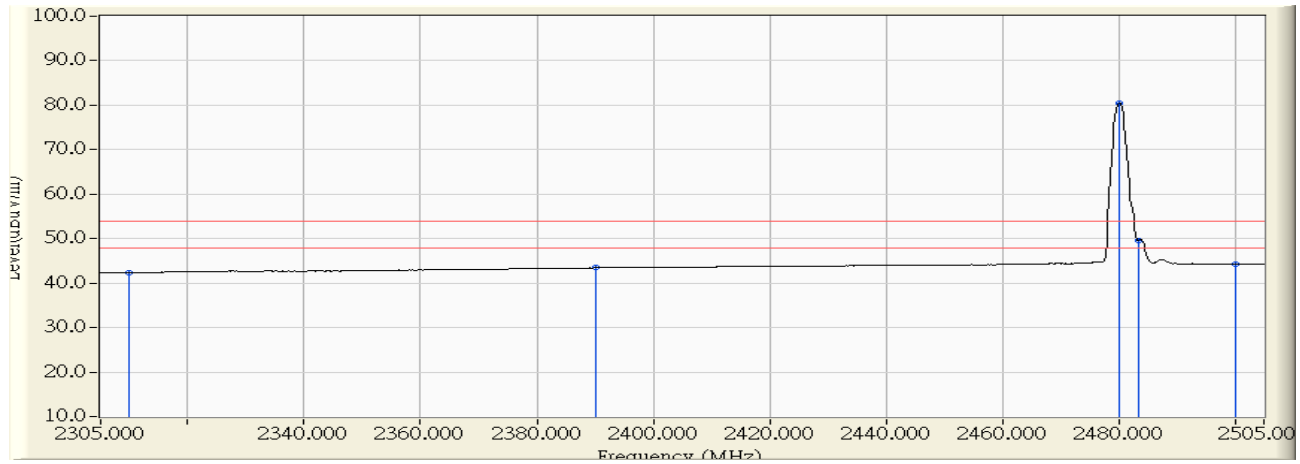

	Frequency (MHz)	Correct Factor (dB)	Reading Level (dBuV)	Measure Level (dBuV/m)	Margin (dB)	Limit (dBuV/m)	Detector Type
1	2310.000	30.411	11.908	42.319	-11.651	53.970	AVERAGE
2	2390.000	31.241	12.227	43.468	-10.502	53.970	AVERAGE
3	* 2480.200	31.989	48.539	80.527	26.557	53.970	AVERAGE
4	2483.500	31.980	17.601	49.580	-4.390	53.970	AVERAGE
5	2500.000	31.934	12.371	44.306	-9.664	53.970	AVERAGE

Note:

1. All readings above 1GHz are performed with peak and/or average measurements as necessary.
2. Peak measurements: RBW = 1MHz, VBW = 1MHz, Sweep: Auto.
3. Average measurements: RBW = 1MHz, VBW = 10 Hz, Sweep: Auto.
4. “ * ”, means this data is the worst emission level.
5. Measurement Level = Reading Level + Correct Factor.
6. The average measurement was not performed when the peak measured data under the limit of average detection. If the readings given are average, peak measurement should also be supplied.

7. Number of hopping frequency

7.1. Test Equipment

The following test equipment is used during the test:

Number of hopping frequency / SR7

Instrument	Manufacturer	Model No.	Serial No	Next Cal. Date
Spectrum Analyzer	Agilent	N9010A-EXA	US47140172	2015/07/14

Note: 1. All equipments that need to calibrate are with calibration period of 1 year.

7.2. Test Setup

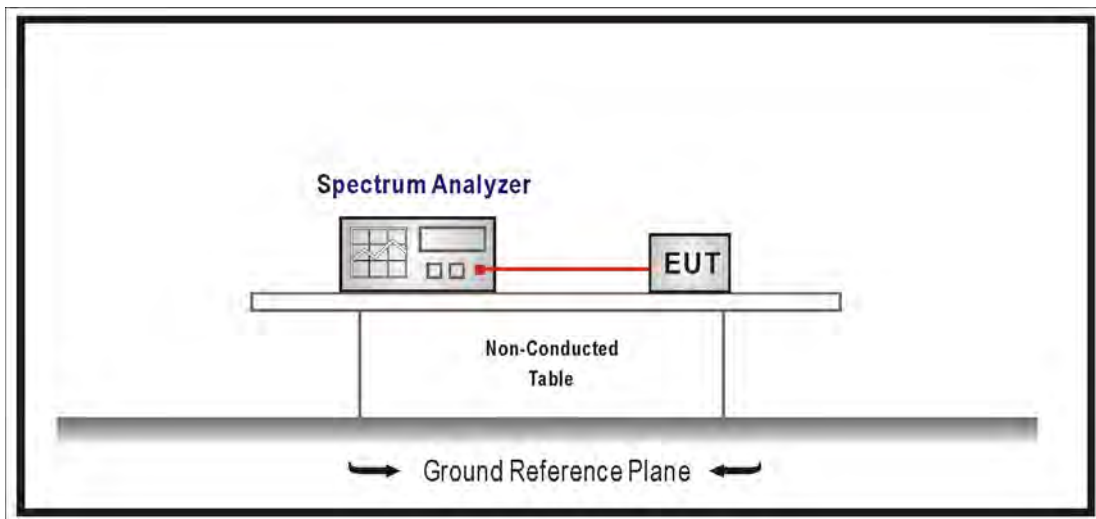

7.3. Limits

For frequency hopping systems operating in the 902-928 MHz band: if the 20 dB bandwidth of the hopping channel is less than 250 kHz, the system shall use at least 50 hopping frequencies and the average time of occupancy on any frequency shall not be greater than 0.4 seconds within a 20 second period; if the 20 dB bandwidth of the hopping channel is 250 kHz or greater, the system shall use at least 25 hopping frequencies and the average time of occupancy on any frequency shall not be greater than 0.4 seconds within a 10 second period. The maximum allowed 20 dB bandwidth of the hopping channel is 500 kHz.

For frequency hopping systems operating in the 2400-2483.5 MHz bands, which use fewer than 75 hopping frequencies, may employ intelligent hopping techniques to avoid interference to other transmissions. Frequency hopping systems may avoid or suppress transmissions on a particular hopping frequency provided that a minimum of 15 non-overlapping channels are used.

For frequency hopping systems operating in the 5725-5850 MHz band shall use at least 75 hopping frequencies.

7.4. Test Procedures

The EUT was setup according to ANSI C63.10 and tested according to FHSS test procedure of FCC Public Notice DA 00-705 for compliance to FCC 47CFR 15.247 requirements ,
Span = the frequency band of operation , $RBW \geq 1\%$ of the span , $VBW \geq RBW$,
Sweep = auto, Detector function = peak, Trace = max hold.

7.5. Test Specification

According to FCC Part 15 Subpart C Paragraph 15.247: 2013

7.6. Test Result

Product	SkyCaddie		
Test Item	Number of hopping frequency		
Test Mode	Mode 1: Transmit (Power by PC)		
Date of Test	2014/10/13	Test Site	SR7

Frequency Range (MHz)	Measure Level (Channels)	Limit (Channels)	Result
2402 ~ 2480	79	≥ 75	Pass

2401.5-2420.5MHz

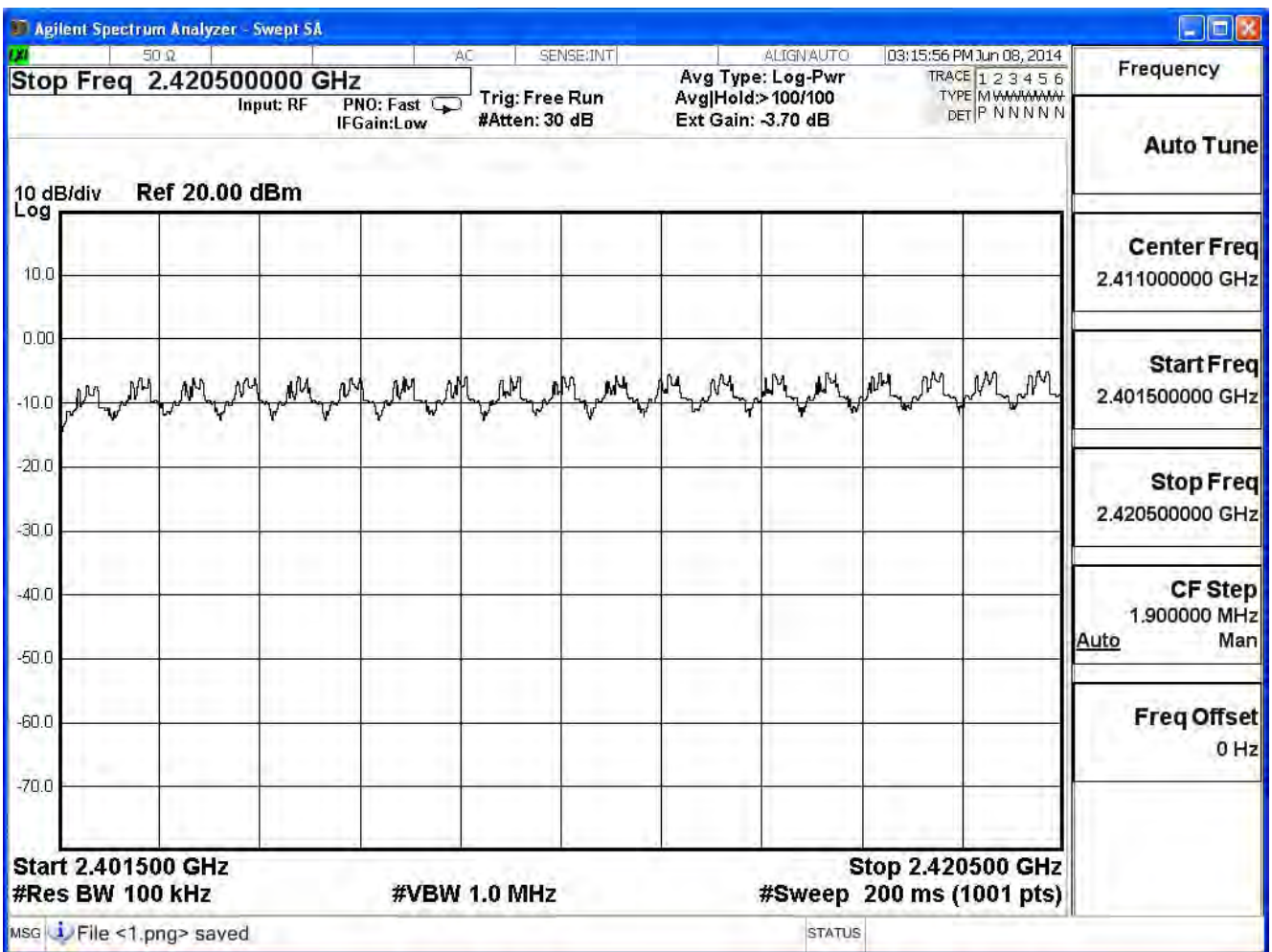

2420.5-2440.5MHz

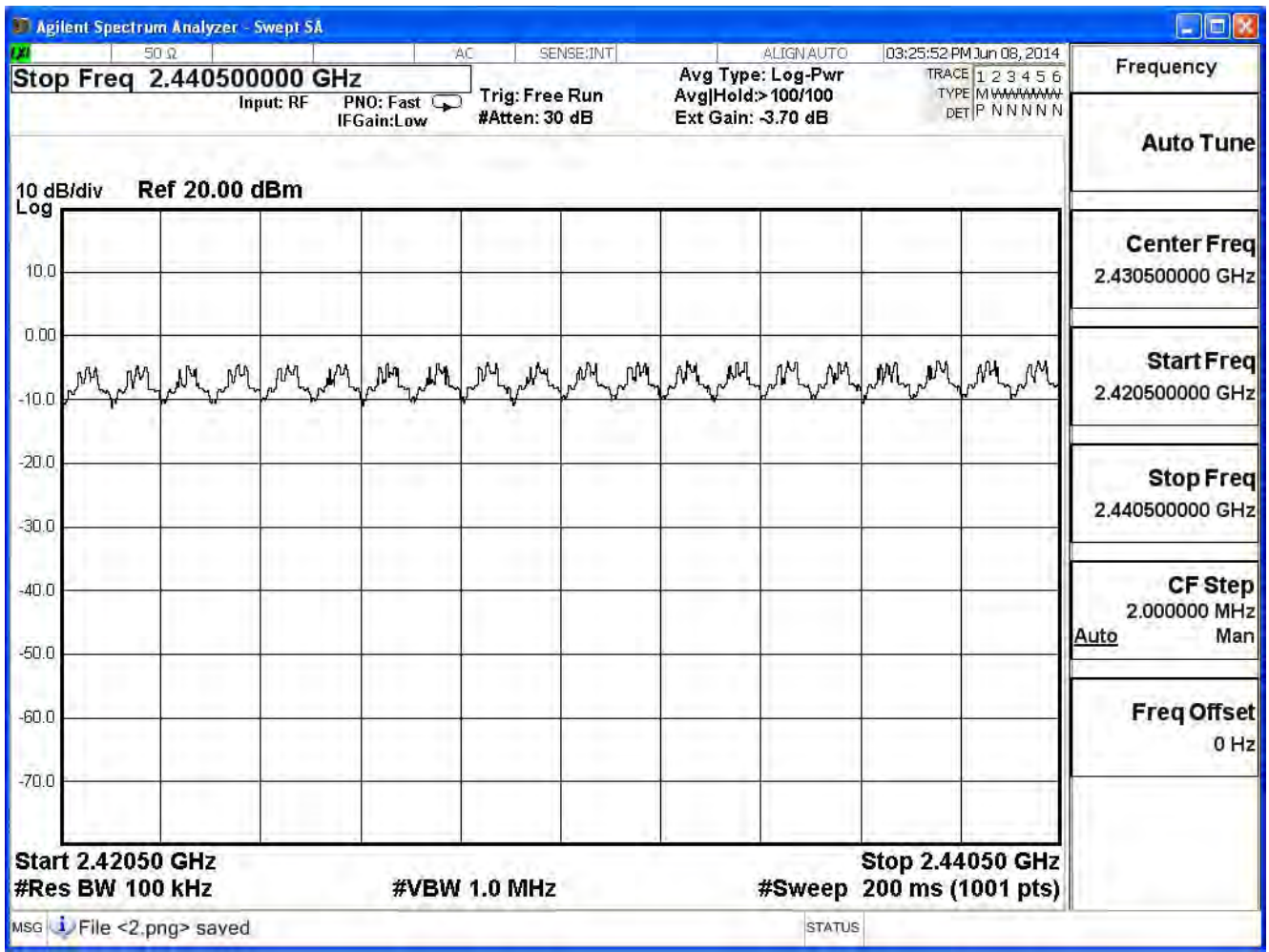

2440.5-2460.5MHz

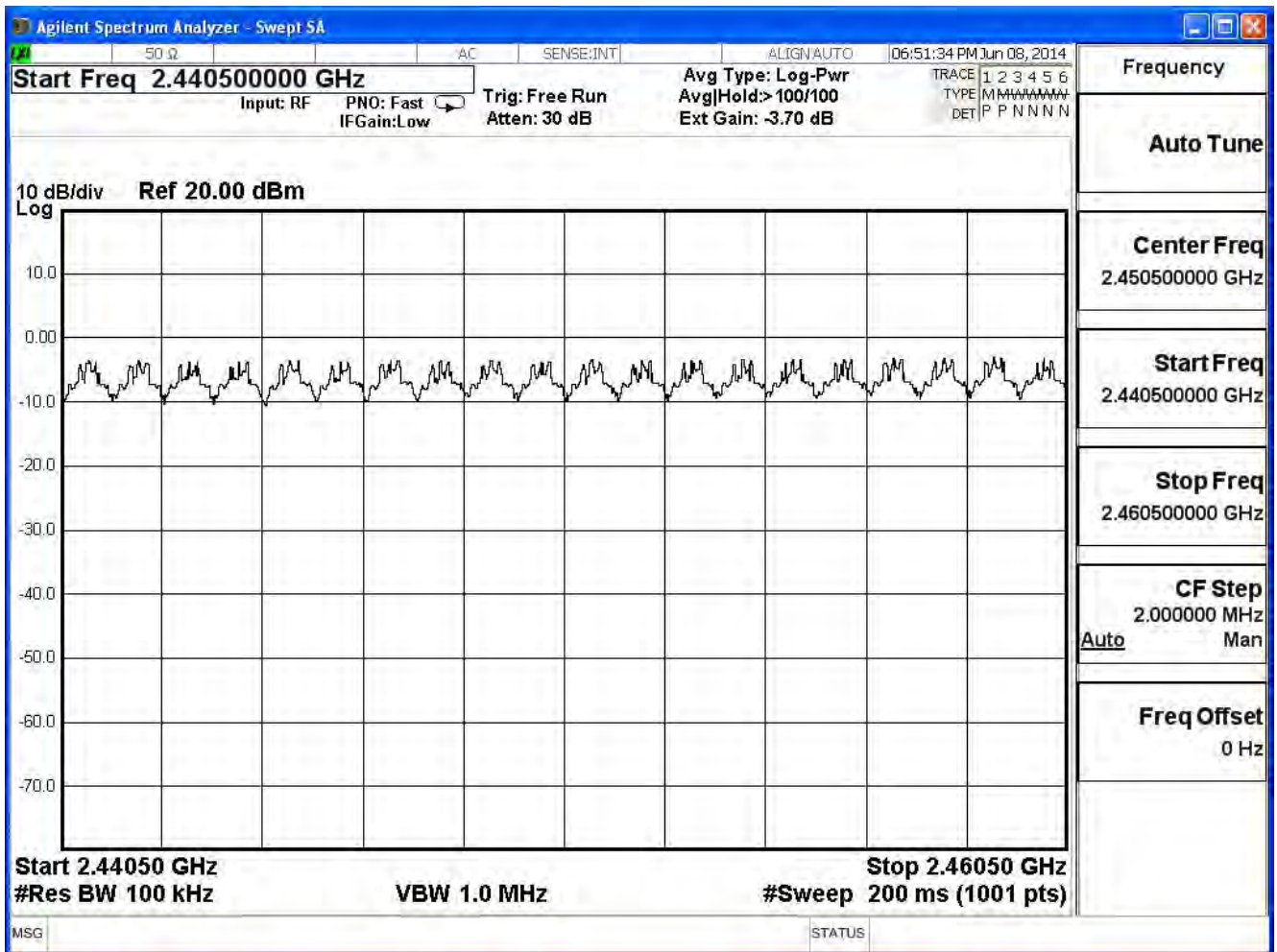

2460.5-2480.5MHz

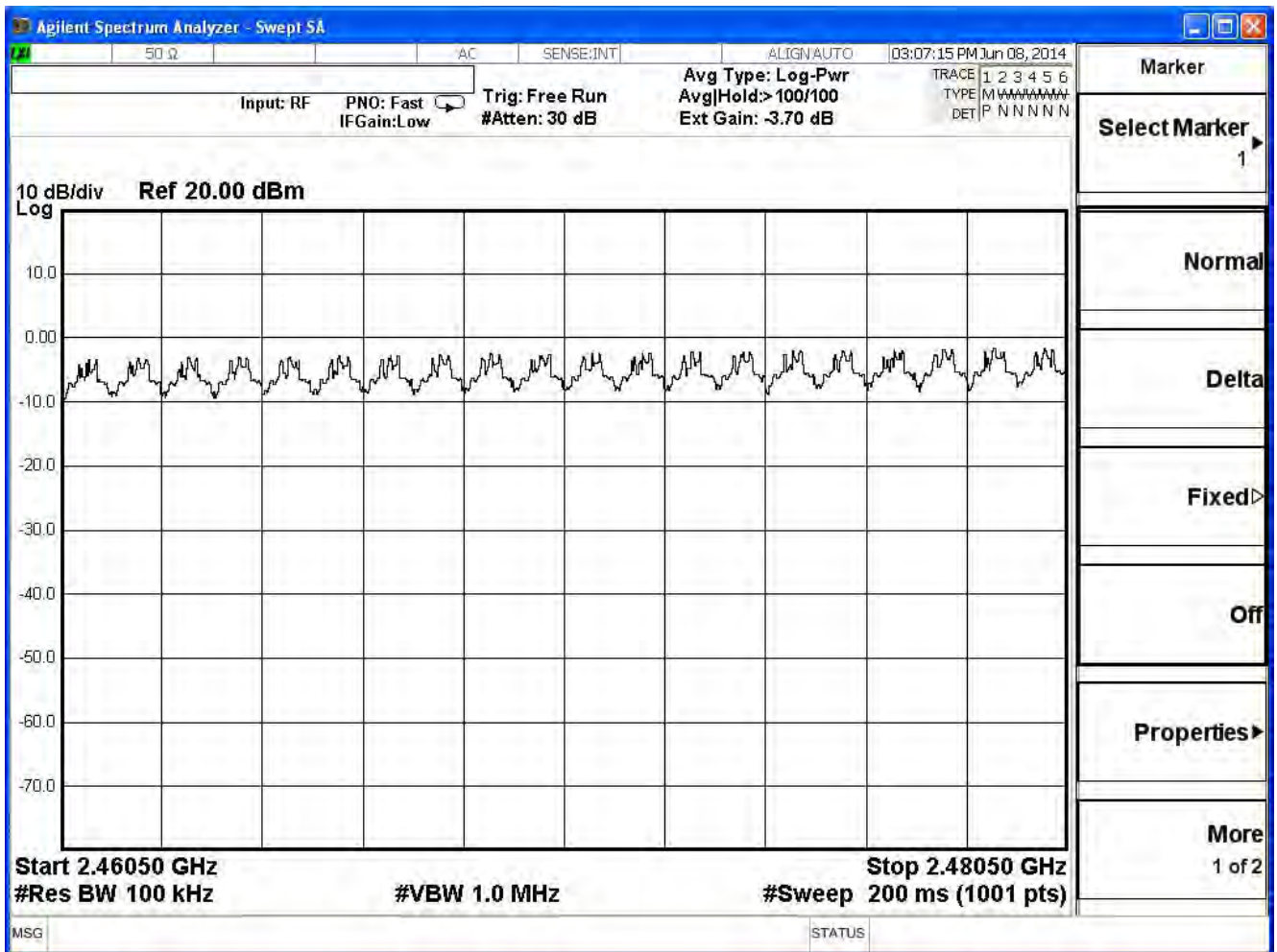

8. Carrier Frequency Separation

8.1. Test Equipment

The following test equipment is used during the test:

Carrier Frequency Separation / SR7

Instrument	Manufacturer	Model No.	Serial No	Next Cal. Date
Spectrum Analyzer	Agilent	N9010A-EXA	US47140172	2015/07/14

Note: 1. All equipments that need to calibrate are with calibration period of 1 year.

8.2. Test Setup

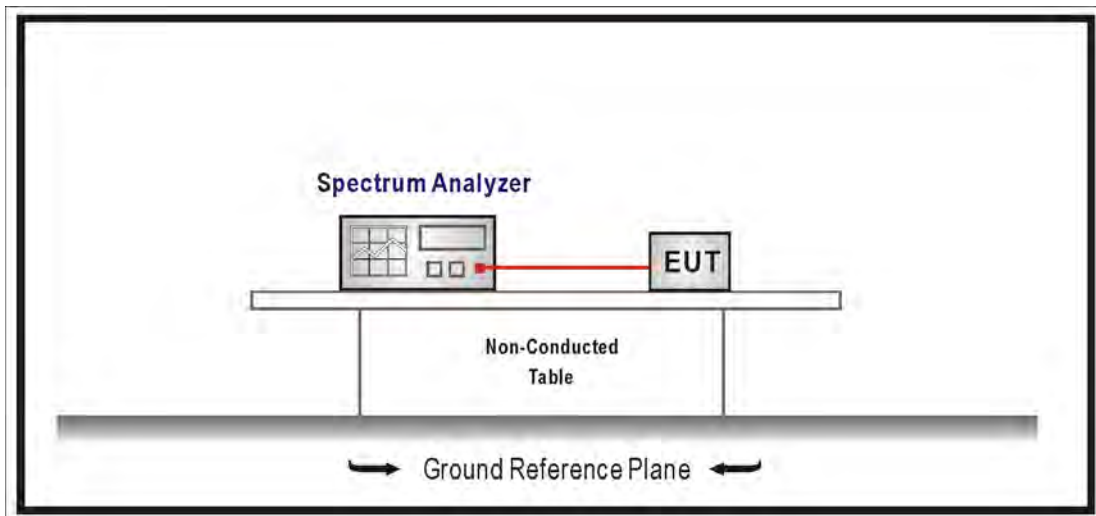

8.3. Limits

For frequency hopping systems shall have hopping channel carrier frequencies separated by a minimum of 25 kHz or two-thirds of the 20 dB bandwidth of the hopping channel, whichever is greater.

8.4. Test Procedures

The EUT was setup according to ANSI C63.10 and tested according to FHSS test procedure of FCC Public Notice DA 00-705 for compliance to FCC 47CFR 15.247 requirements

Span = wide enough to capture the peaks of two adjacent channels

Resolution Bandwidth (RBW) \geq 1% of the span, VBW \geq RBW

Sweep = auto, Detector function = peak, Trace = max hold

8.5. Test Specification

According to FCC Part 15 Subpart C Paragraph 15.247: 2013

8.6. Test Result

Product	SkyCaddie		
Test Item	Carrier Frequency Separation		
Test Mode	Mode 1: Transmit (Power by PC)		
Date of Test	2014/10/13	Test Site	SR7

$\pi/4$ -DQPSK

Channel No.	Frequency (MHz)	Measure Level (MHz)	Limit (MHz)	Result
00	2402	1.00	20.909	Pass

Channel 00

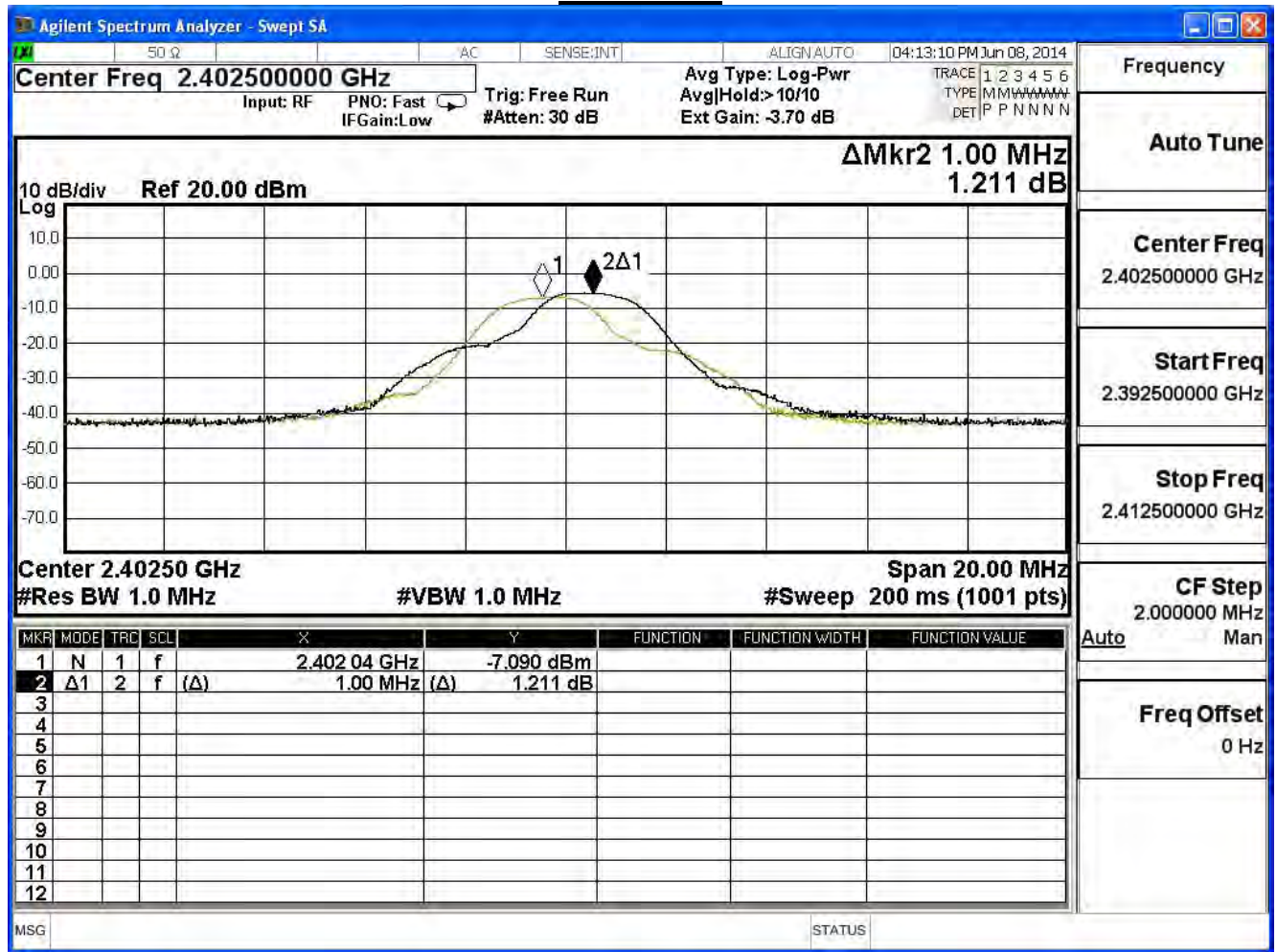

Product	SkyCaddie		
Test Item	Carrier Frequency Separation		
Test Mode	Mode 1: Transmit (Power by PC)		
Date of Test	2014/10/13	Test Site	SR7

$\pi/4$ -DQPSK

Channel No.	Frequency (MHz)	Measure Level (MHz)	Limit (MHz)	Result
39	2441	1.02	20.907	Pass

Channel 39

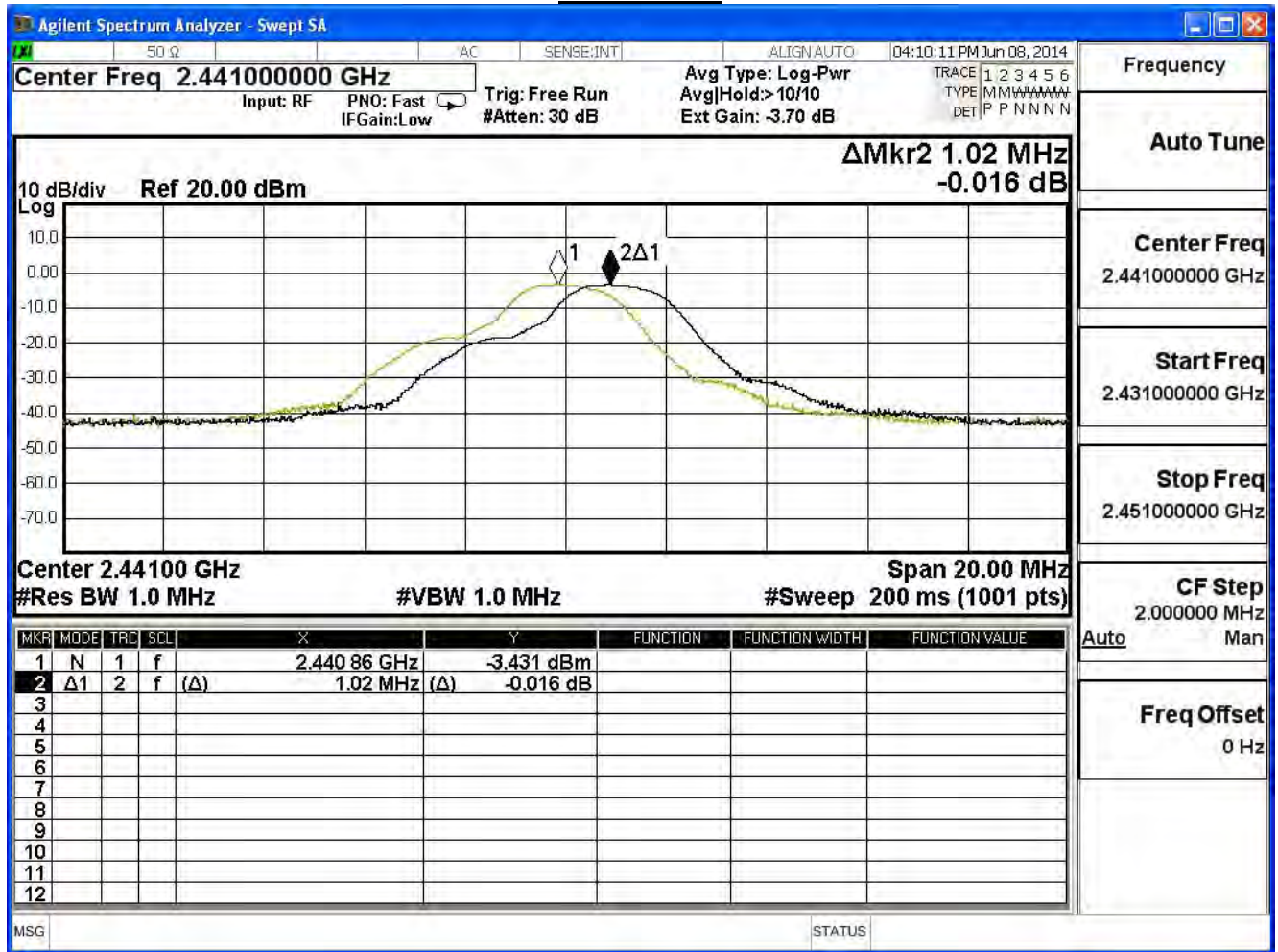

Product	SkyCaddie		
Test Item	Carrier Frequency Separation		
Test Mode	Mode 1: Transmit (Power by PC)		
Date of Test	2014/10/13	Test Site	SR7

$\pi/4$ -DQPSK

Channel No.	Frequency (MHz)	Measure Level (MHz)	Limit (MHz)	Result
78	2480	1.00	20.907	Pass

Channel 78

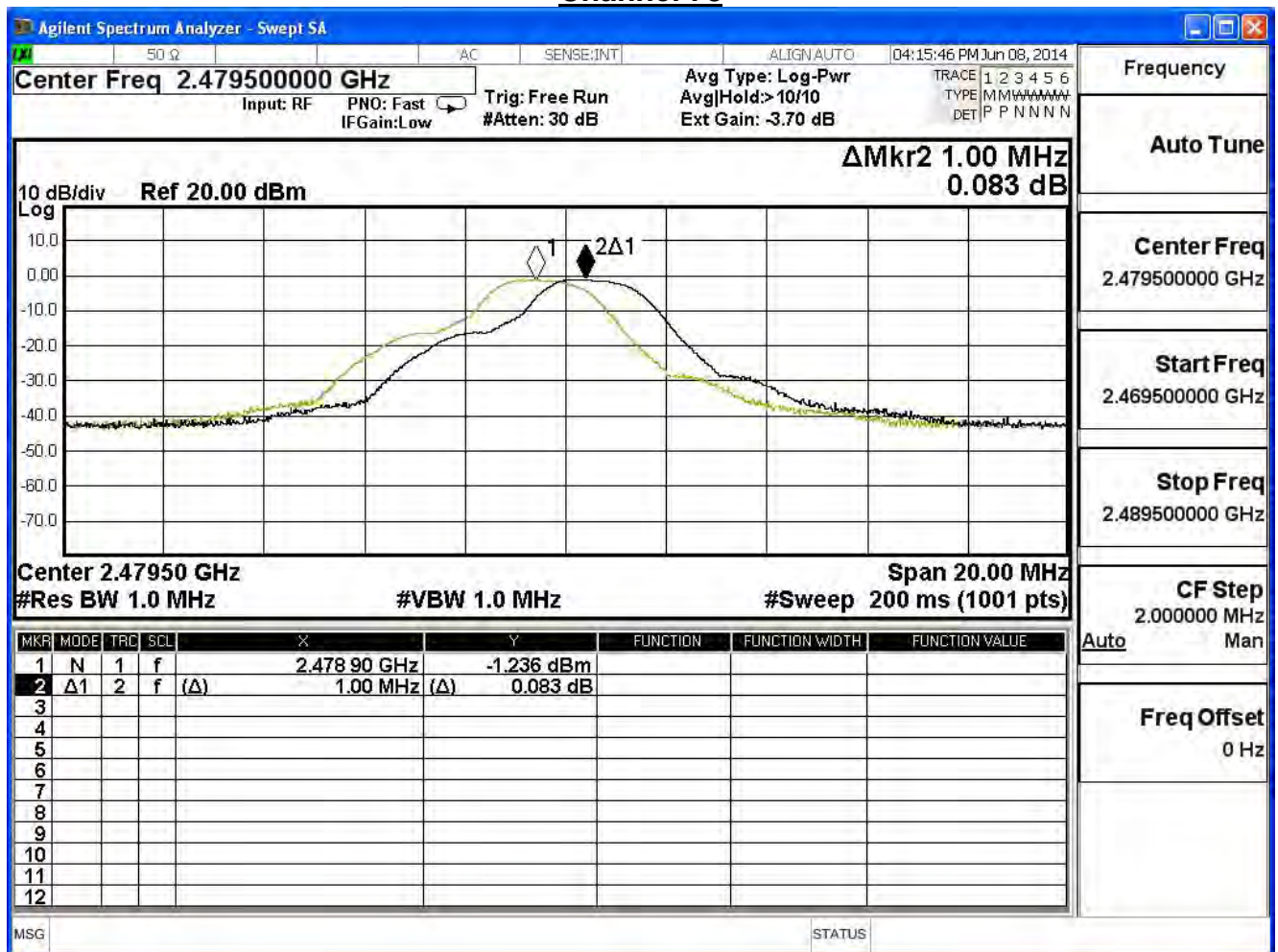

Product	SkyCaddie		
Test Item	Carrier Frequency Separation		
Test Mode	Mode 2: Transmit (Power by Adapter)		
Date of Test	2014/10/13	Test Site	SR7

8-DQPSK

Channel No.	Frequency (MHz)	Measure Level (MHz)	Limit (MHz)	Result
00	2402	1.00	20.911	Pass

Channel 00

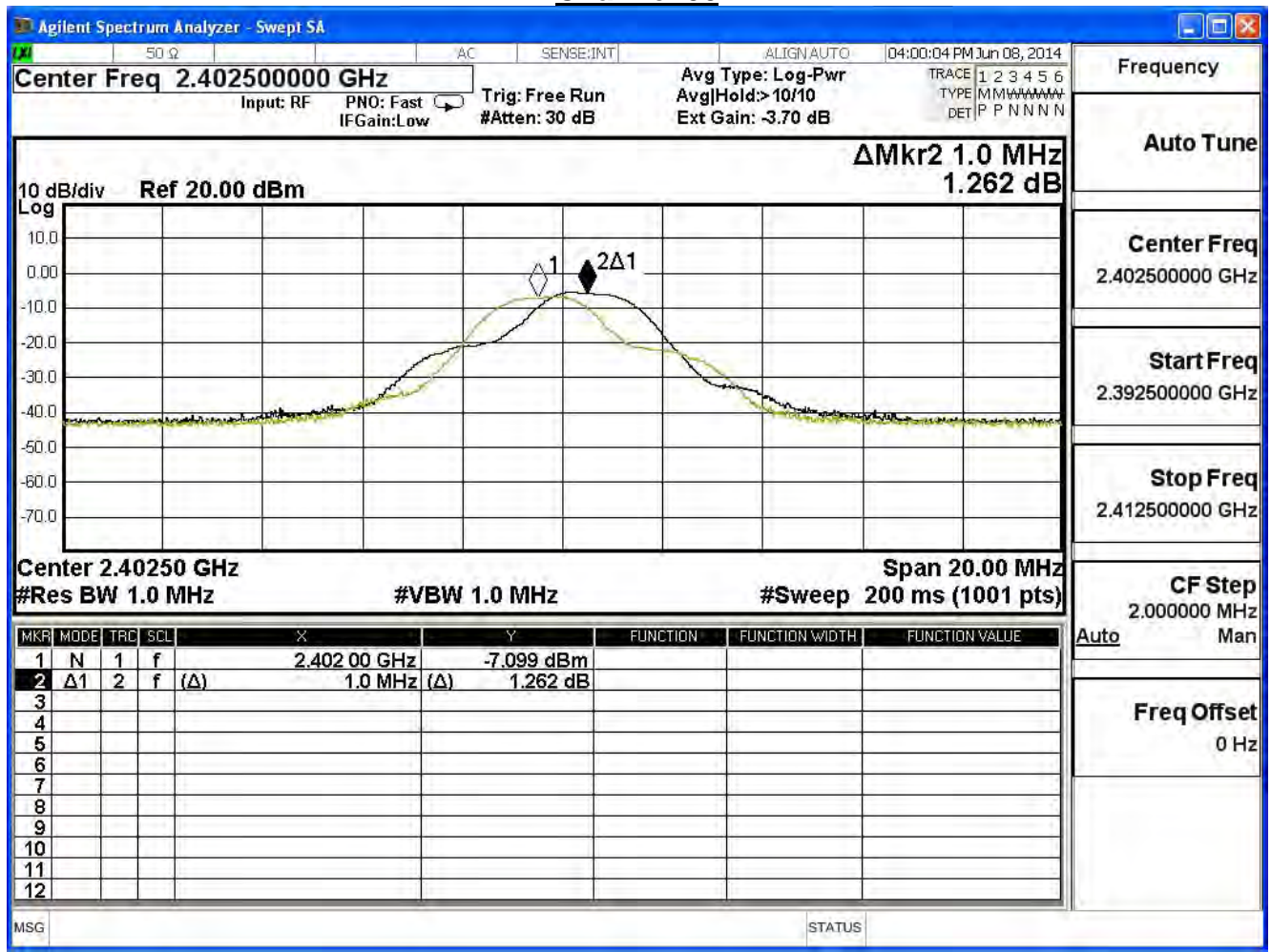

Product	SkyCaddie		
Test Item	Carrier Frequency Separation		
Test Mode	Mode 2: Transmit (Power by Adapter)		
Date of Test	2014/10/13	Test Site	SR7

8-DQPSK

Channel No.	Frequency (MHz)	Measure Level (MHz)	Limit (MHz)	Result
39	2441	1.00	20.910	Pass

Channel 39

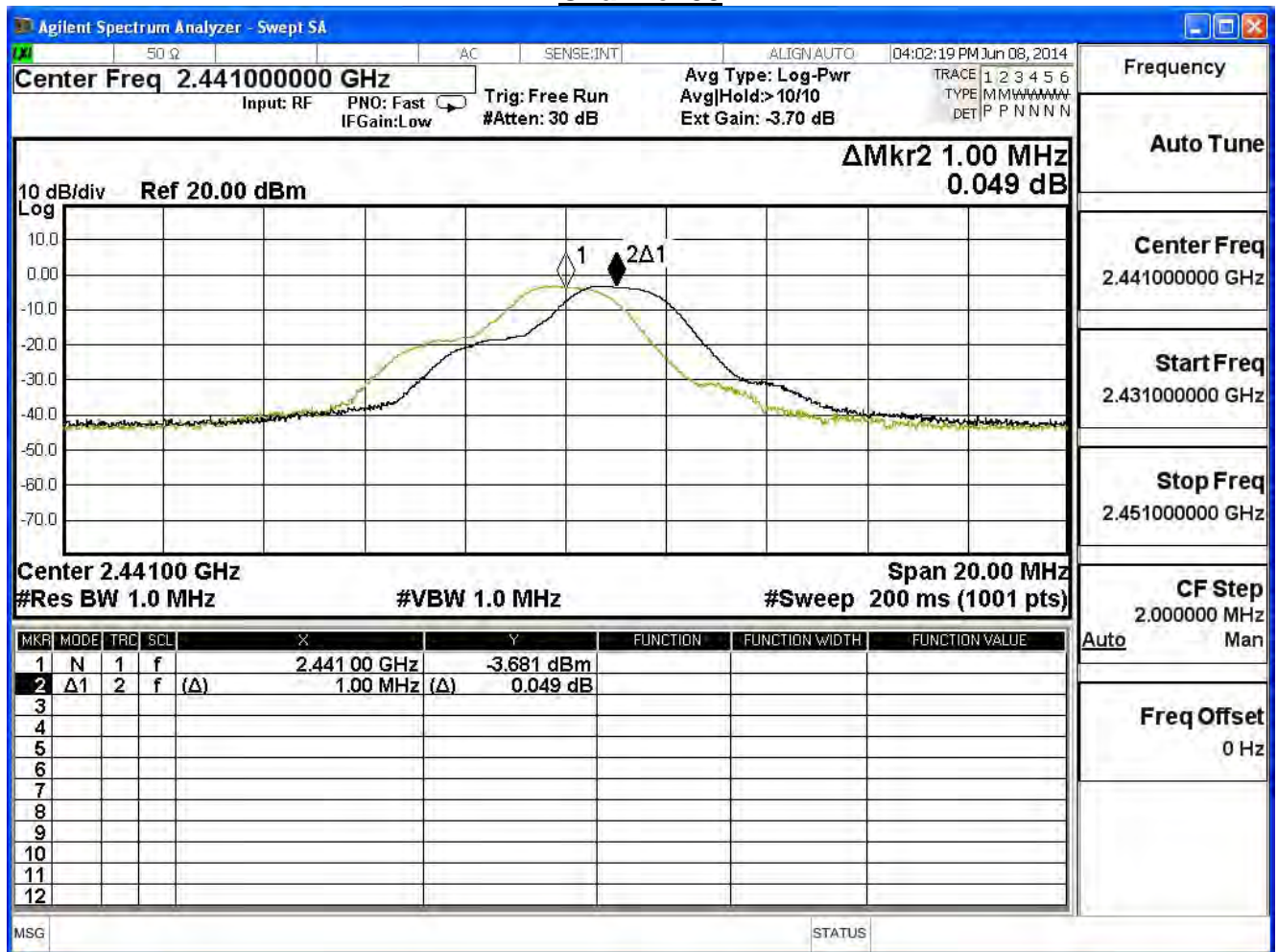

Product	SkyCaddie		
Test Item	Carrier Frequency Separation		
Test Mode	Mode 2: Transmit ($\pi/4$ DQPSK)_Power by PC		
Date of Test	2014/10/13	Test Site	SR7

8-DQPSK

Channel No.	Frequency (MHz)	Measure Level (MHz)	Limit (MHz)	Result
78	2480	1.00	20.911	Pass

Channel 78

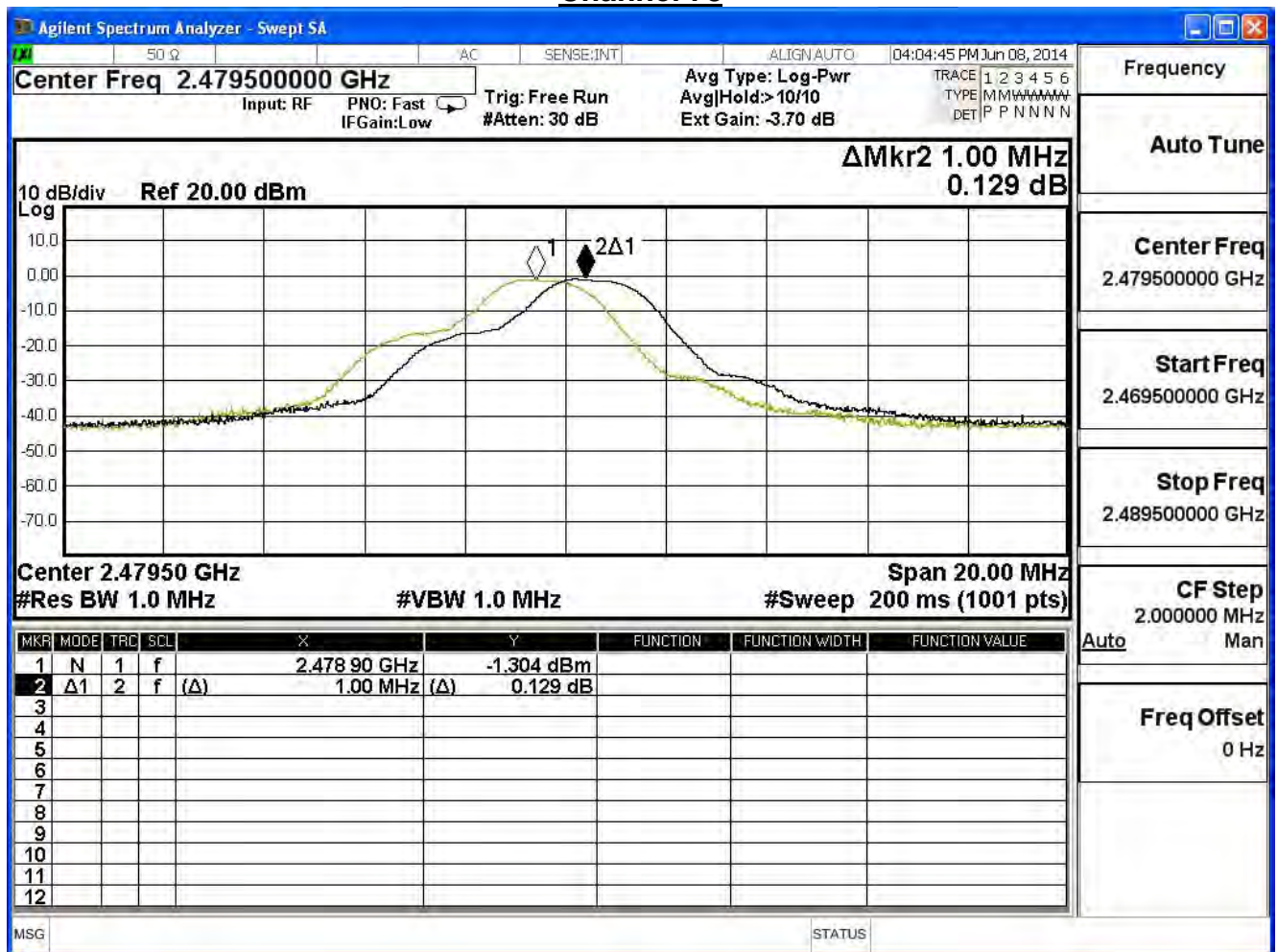

9. Occupied Bandwidth

9.1. Test Equipment

The following test equipment is used during the test:

Occupied Bandwidth / SR7

Instrument	Manufacturer	Model No.	Serial No	Next Cal. Date
Spectrum Analyzer	Agilent	N9010A-EXA	US47140172	2015/07/14

Note: 1. All equipments that need to calibrate are with calibration period of 1 year.

9.2. Test Setup

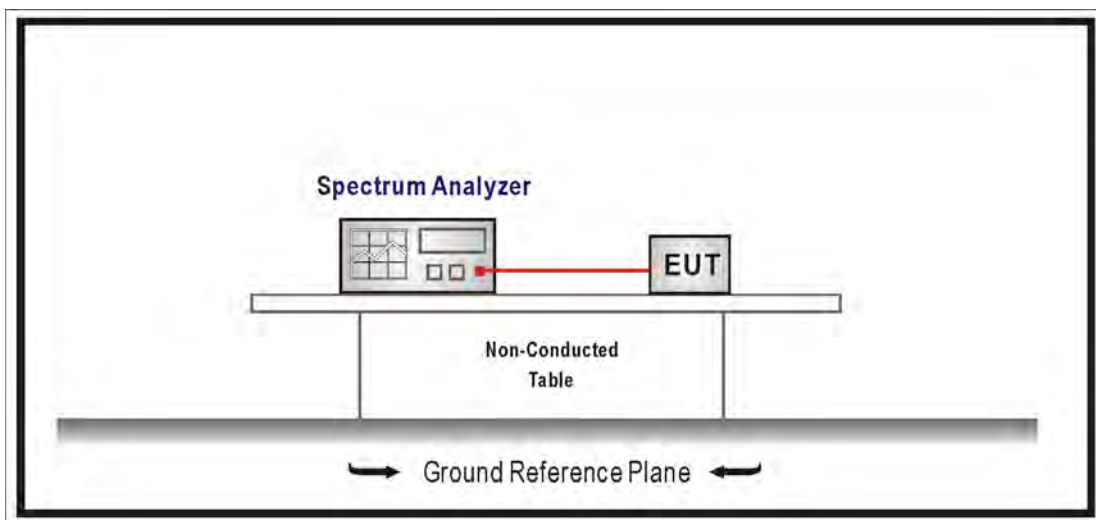

9.3. Limits

For frequency hopping systems operating in the 902-928 MHz band: if the 20 dB bandwidth of the hopping channel is less than 250 kHz, the system shall use at least 50 hopping frequencies and the average time of occupancy on any frequency shall not be greater than 0.4 seconds within a 20 second period; if the 20 dB bandwidth of the hopping channel is 250 kHz or greater, the system shall use at least 25 hopping frequencies and the average time of occupancy on any frequency shall not be greater than 0.4 seconds within a 10 second period. The maximum allowed 20 dB bandwidth of the hopping channel is 500 kHz.

For frequency hopping systems operating in the 5725-5850 MHz bands. The maximum 20 dB bandwidth of the hopping channel is 1 MHz.

For frequency hopping systems shall have hopping channel carrier frequencies separated by a minimum of 25 kHz or the 20 dB bandwidth of the hopping channel, whichever is greater.

9.4. Test Procedures

The EUT was setup according to ANSI C63.10 and tested according to FHSS test procedure of FCC Public Notice DA 00-705 for compliance to FCC 47CFR 15.247 requirements

Use the following spectrum analyzer settings:

Span = approximately 2 to 3 times the 20 dB bandwidth, centered on a hopping channel

RBW \geq 1% of the 20 dB bandwidth, VBW \geq RBW , Sweep = auto, Detector function = peak,

Trace = max hold , The EUT should be transmitting at its maximum data rate.

9.5. Test Specification

According to FCC Part 15 Subpart C Paragraph 15.247: 2013

9.6. Test Result

Product	SkyCaddie		
Test Item	Occupied Bandwidth		
Test Mode	Mode 1: Transmit (Power by PC)		
Date of Test	2014/10/13	Test Site	SR7

$\pi/4$ -DQPSK

Channel No.	Frequency (MHz)	Measure Level (MHz)	Limit (MHz)	Result
00	2402	1.363	--	Pass

Channel 00

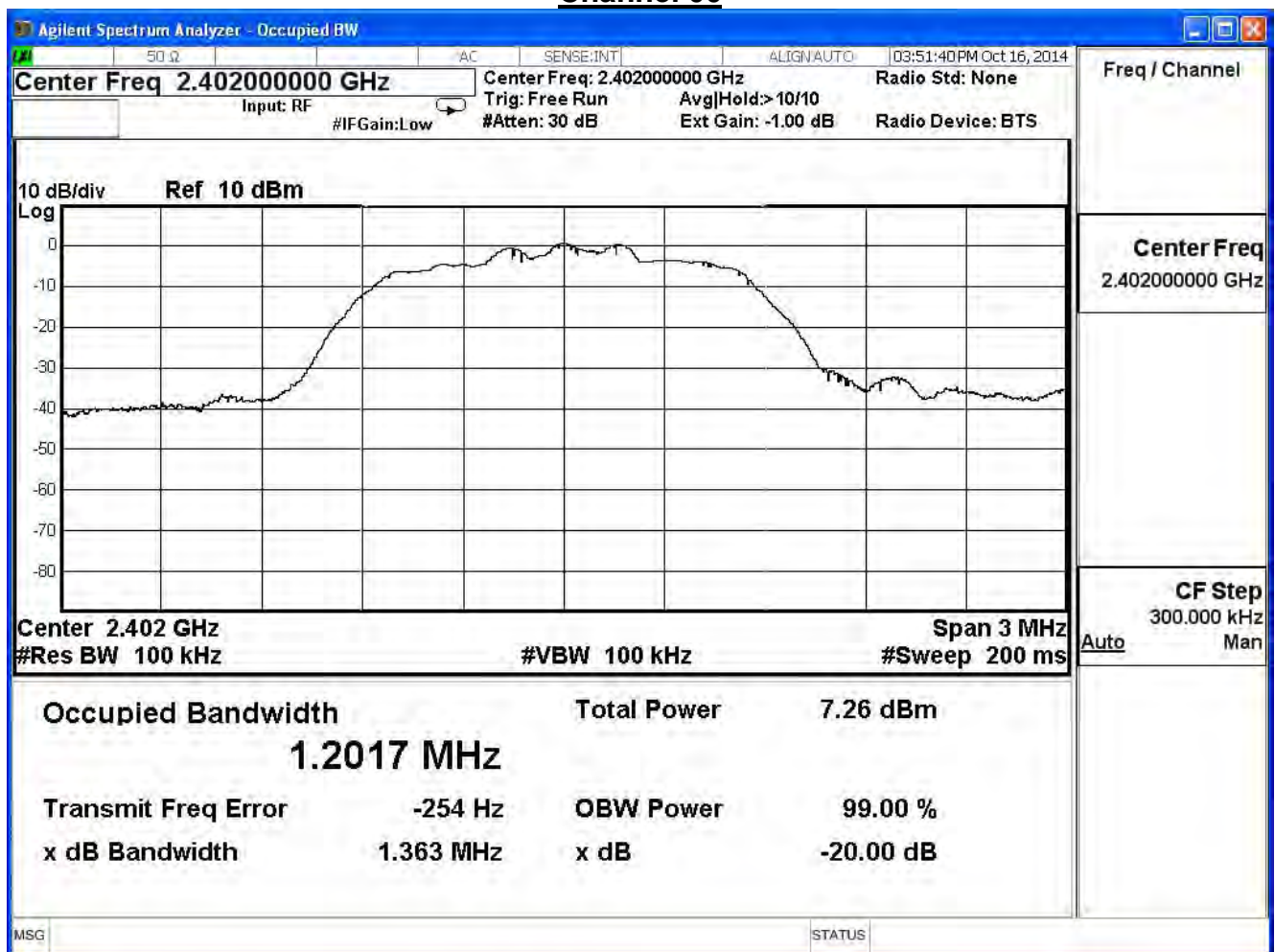

Product	SkyCaddie		
Test Item	Occupied Bandwidth		
Test Mode	Mode 1: Transmit (Power by PC)		
Date of Test	2014/10/13	Test Site	SR7

$\pi/4$ -DQPSK

Channel No.	Frequency (MHz)	Measure Level (MHz)	Limit (MHz)	Result
39	2441	1.361	--	Pass

Channel 39

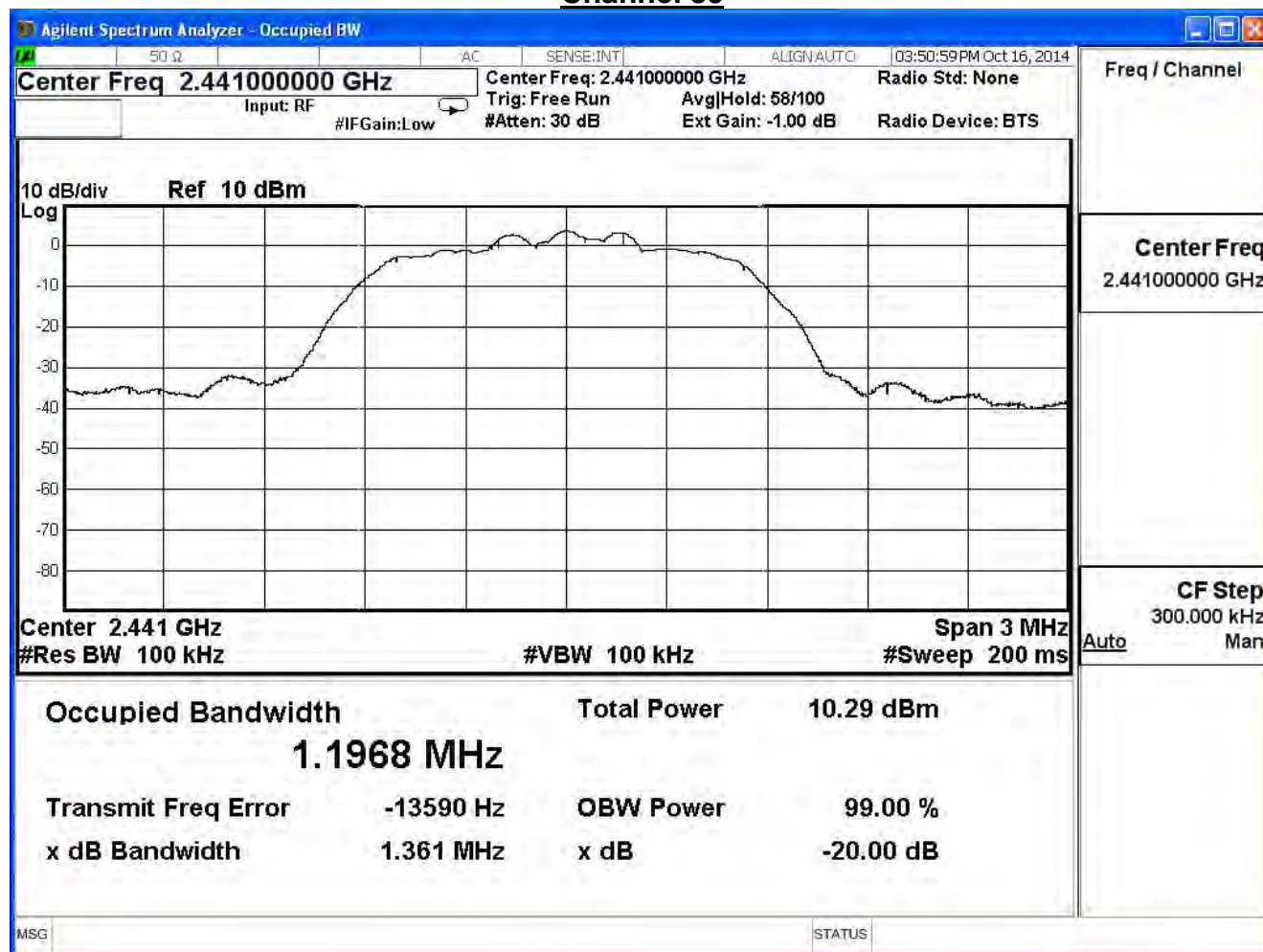

Product	SkyCaddie		
Test Item	Occupied Bandwidth		
Test Mode	Mode 1: Transmit (Power by PC)		
Date of Test	2014/10/13	Test Site	SR7

$\pi/4$ -DQPSK

Channel No.	Frequency (MHz)	Measure Level (MHz)	Limit (MHz)	Result
78	2480	1.361	--	Pass

Channel 78

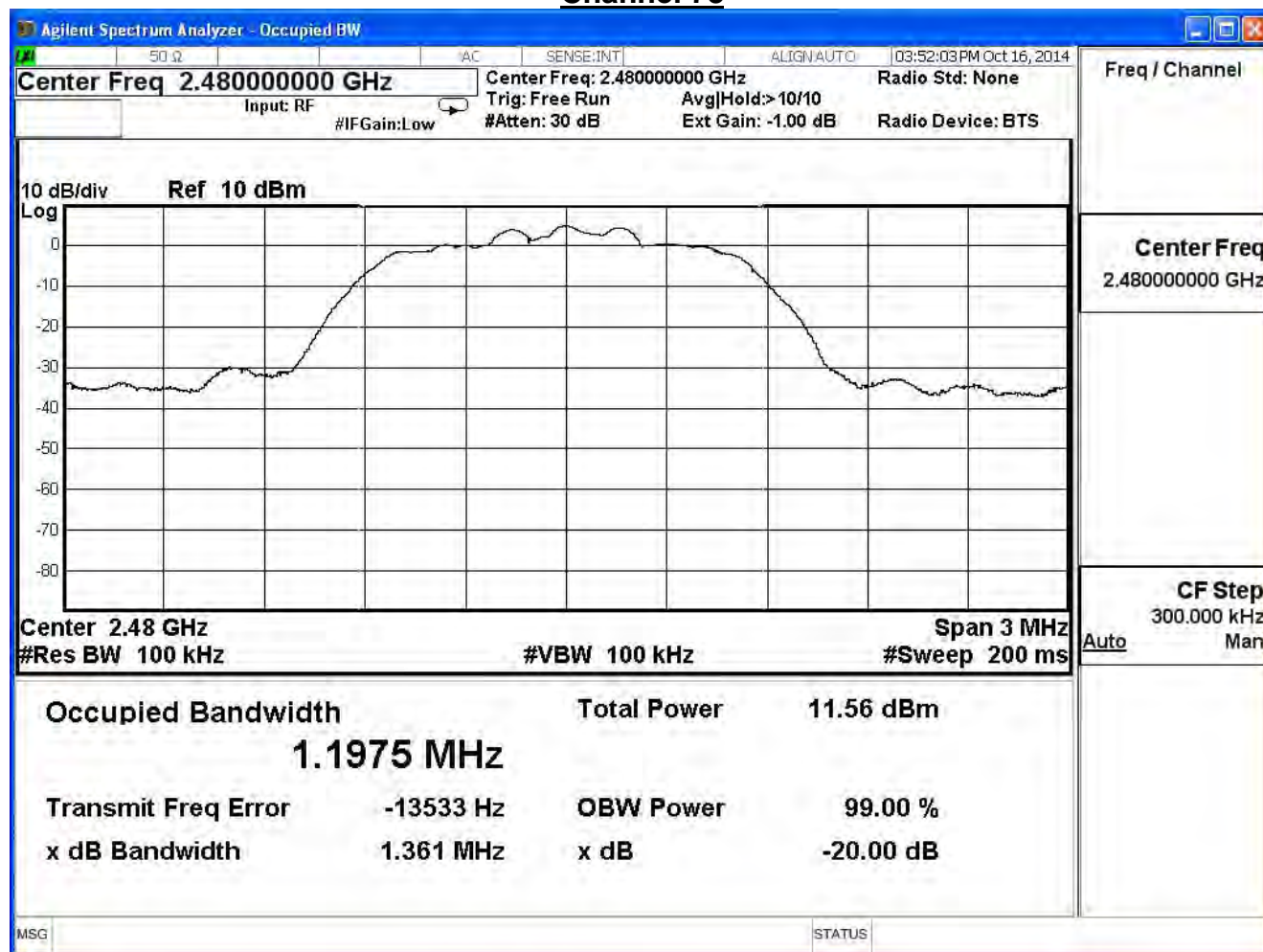

Product	SkyCaddie		
Test Item	Occupied Bandwidth		
Test Mode	Mode 1: Transmit (Power by PC)		
Date of Test	2014/10/13	Test Site	SR7

8-DQPSK

Channel No.	Frequency (MHz)	Measure Level (MHz)	Limit (MHz)	Result
00	2402	1.367	--	Pass

Channel 00

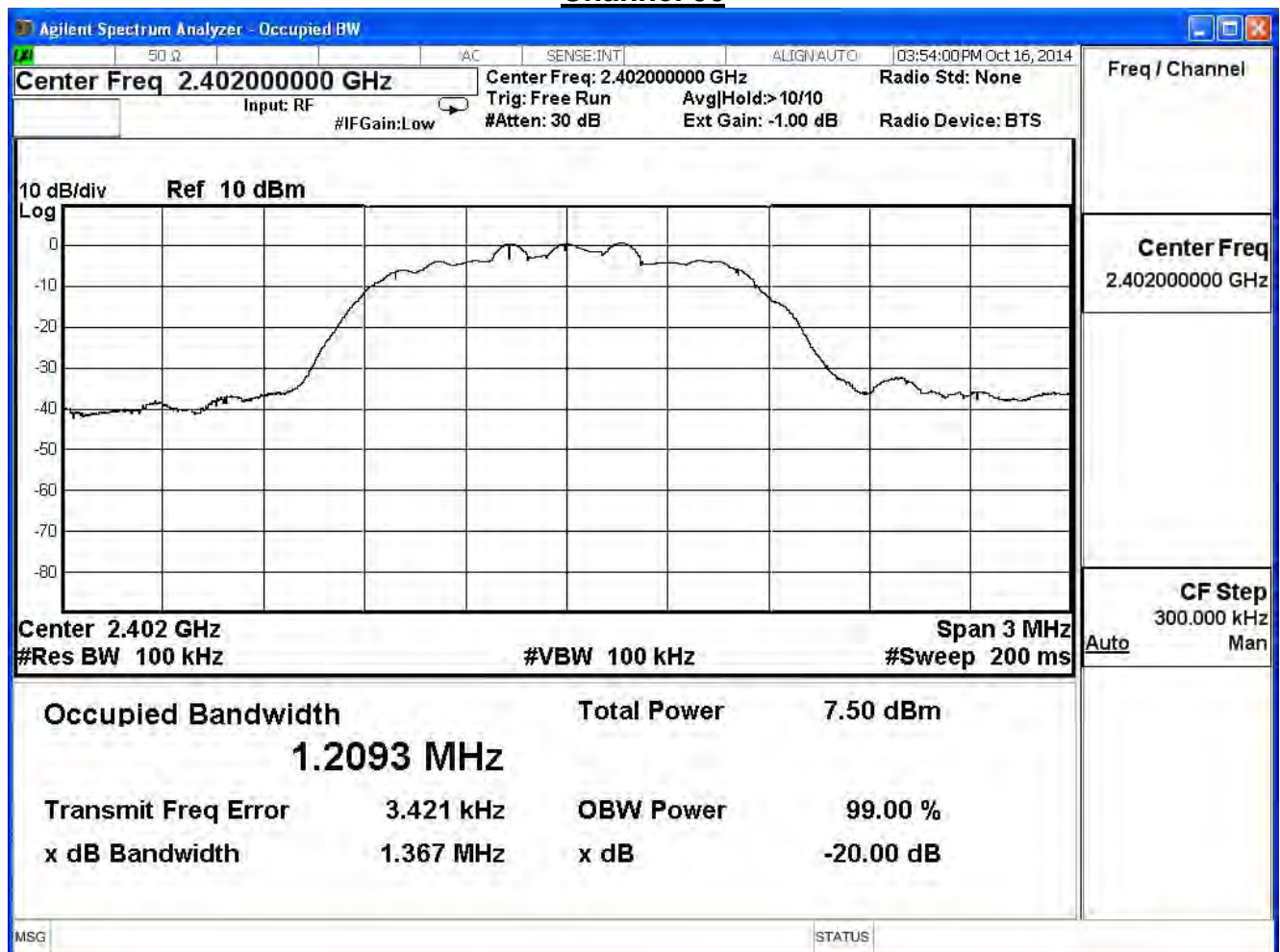

Product	SkyCaddie		
Test Item	Occupied Bandwidth		
Test Mode	Mode 1: Transmit (Power by PC)		
Date of Test	2014/10/13	Test Site	SR7

8-DQPSK

Channel No.	Frequency (MHz)	Measure Level (MHz)	Limit (MHz)	Result
39	2441	1.365	--	Pass

Channel 39

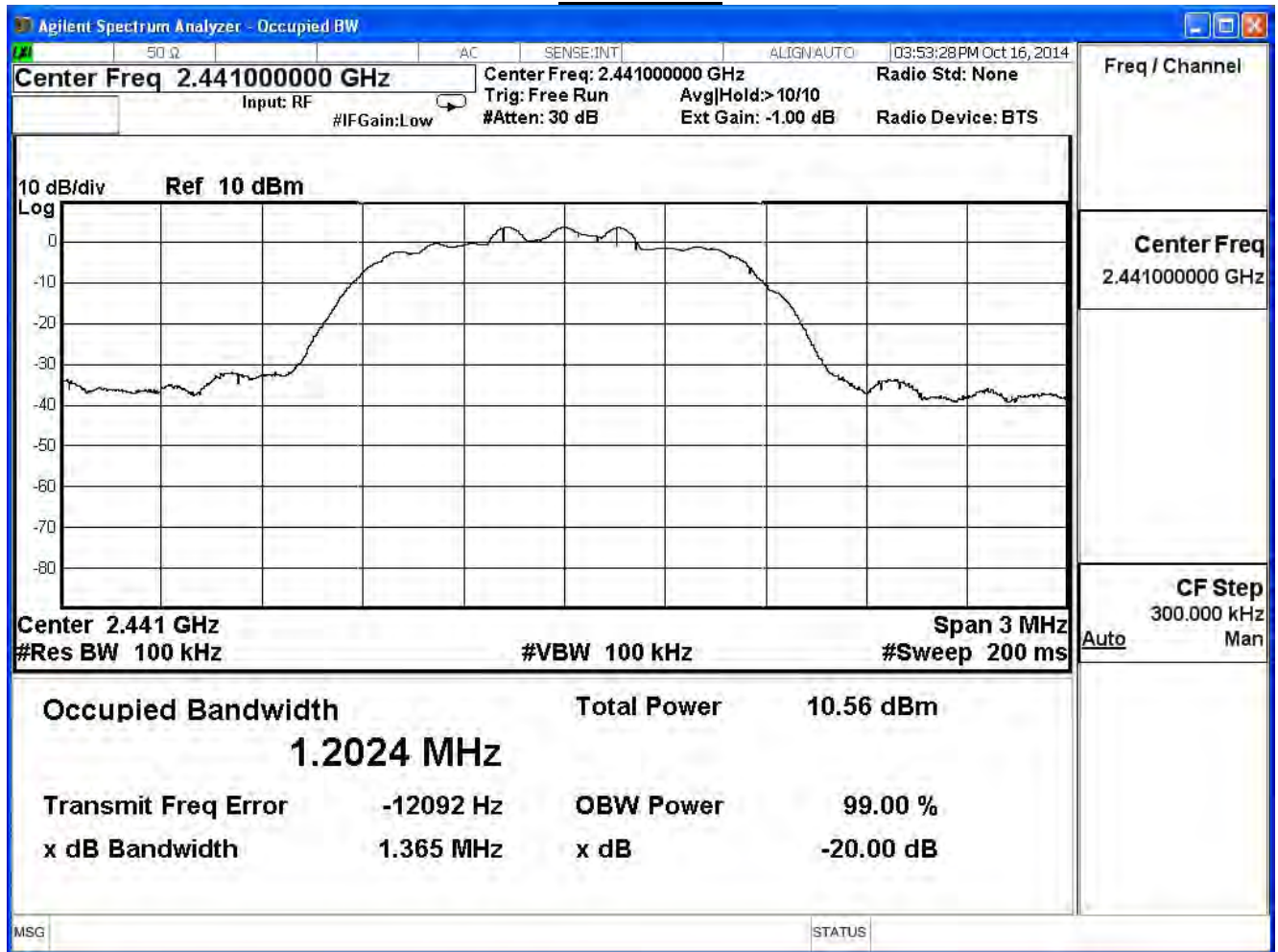

Product	SkyCaddie		
Test Item	Occupied Bandwidth		
Test Mode	Mode 1: Transmit (Power by PC)		
Date of Test	2014/10/13	Test Site	SR7

8-DQPSK

Channel No.	Frequency (MHz)	Measure Level (MHz)	Limit (MHz)	Result
78	2480	1.366	--	Pass

Channel 78

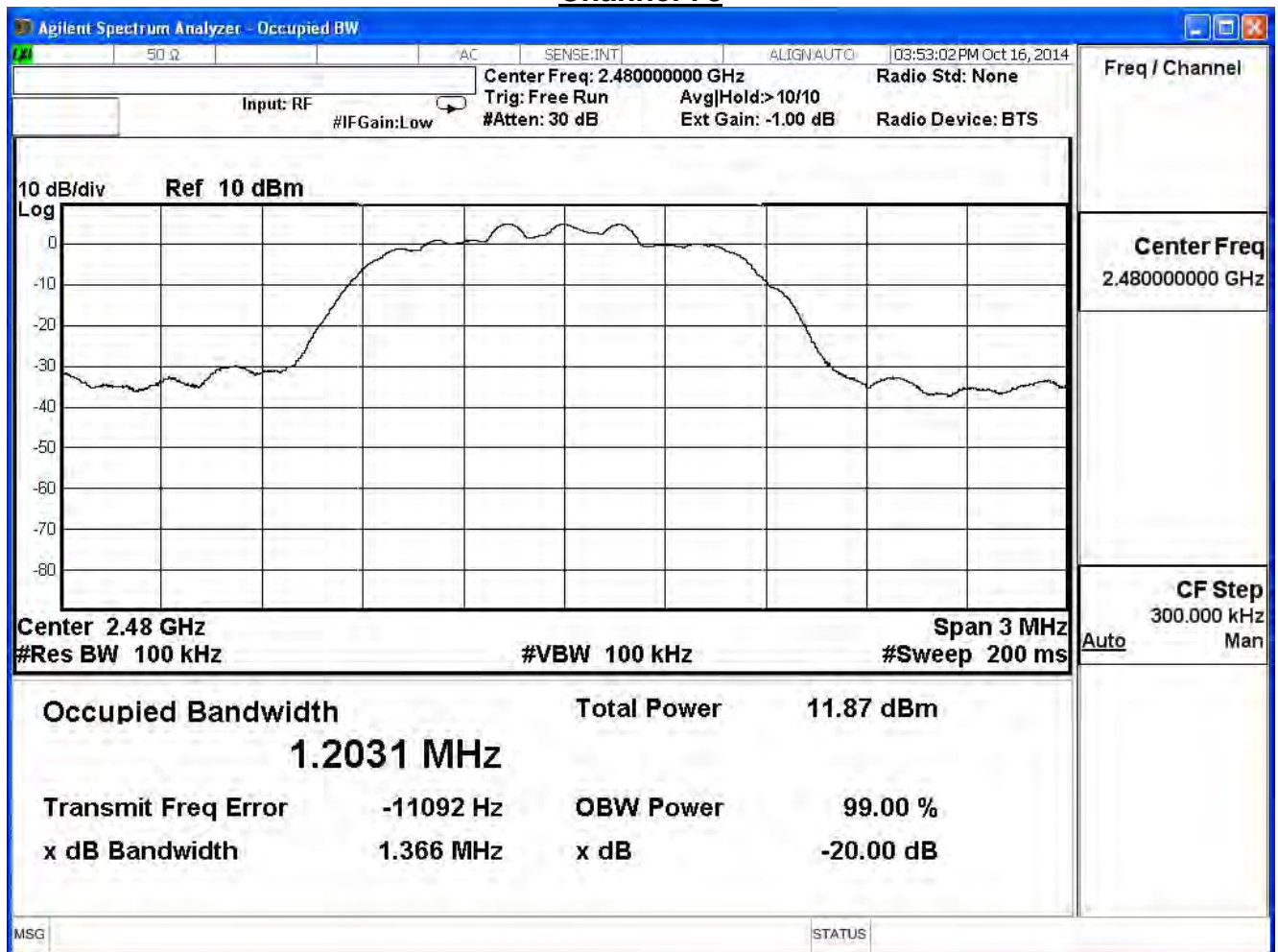

10. Dwell Time

10.1. Test Equipment

The following test equipment is used during the test:

Dwell Time / SR7

Instrument	Manufacturer	Model No.	Serial No	Next Cal. Date
Spectrum Analyzer	Agilent	N9010A-EXA	US47140172	2015/07/14

Note: 1. All equipments that need to calibrate are with calibration period of 1 year.

10.2. Test Setup

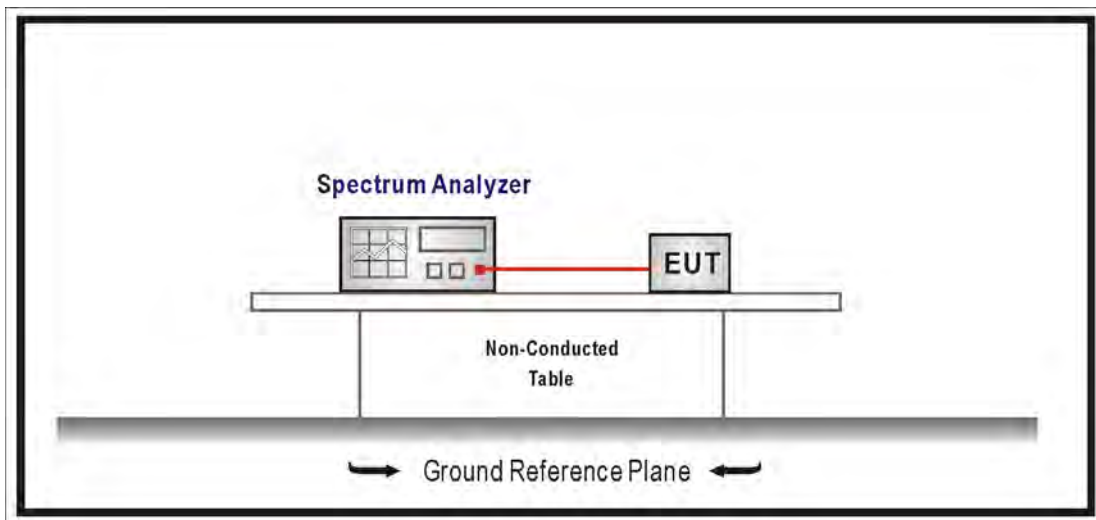

10.3. Limits

For frequency hopping systems operating in the 902-928 MHz band: if the 20 dB bandwidth of the hopping channel is less than 250 kHz, the system shall use at least 50 hopping frequencies and the average time of occupancy on any frequency shall not be greater than 0.4 seconds within a 20 second period; if the 20 dB bandwidth of the hopping channel is 250 kHz or greater, the system shall use at least 25 hopping frequencies and the average time of occupancy on any frequency shall not be greater than 0.4 seconds within a 10 second period. For frequency hopping systems operating in the 2400-2483.5 MHz bands. The average time of occupancy on any channel shall not be greater than 0.4 seconds within a period of 0.4 seconds multiplied by the number of hopping channels employed. For frequency hopping systems operating in the 5725-5850 MHz bands. The average time of occupancy on any frequency shall not be greater than 0.4 seconds within a 30 second period.

10.4. Test Procedures

The EUT was setup according to ANSI C63.10 and tested according to FHSS test procedure of FCC Public Notice DA 00-705 for compliance to FCC 47CFR 15.247 requirements
 Span = zero span, centered on a hopping channel , RBW = 1 MHz, VBW ≥ RBW ,
 Sweep = as necessary to capture the entire dwell time per hopping channel ,
 Detector function = peak, Trace = max hold.

10.5. Test Specification

According to FCC Part 15 Subpart C Paragraph 15.247: 2013

10.6. Test Result

Product	SkyCaddie		
Test Item	Dwell Time		
Test Mode	Mode 1: Transmit (Power by PC)		
Date of Test	2014/10/13	Test Site	SR7

$\pi/4$ -DQPSK, 2DH5

Occupancy Time of Frequency Hopping System

A) 2402MHz Test Time Period: $0.4 \times 79 = 31.60\text{sec}$, Time slot length : 2.872 ms = 0.002872 sec
 Dwell Time : $0.002872 \times (266.67/79) \times 31.60 = 0.3063\text{sec}$ ◦

B) 2441MHz Test Time Period: $0.4 \times 79 = 31.60\text{sec}$, Time slot length : 2.870ms = 0.002870 sec
 Dwell Time : $0.002870 \times (266.67/79) \times 31.60 = 0.3061\text{sec}$ ◦

C) 2480MHz Test Time Period: $0.4 \times 79 = 31.60\text{sec}$, Time slot length : 2.894ms = 0.002894 sec
 Dwell Time : $0.002894 \times (266.67/79) \times 31.60 = 0.3086\text{sec}$ ◦

Test Result: The Average Occupancy Time of Each Highest , Middle and Lowest Channel Is Less Than 0.4sec , And Corresponds to The Standard ◦

Hop rate-2402MHz

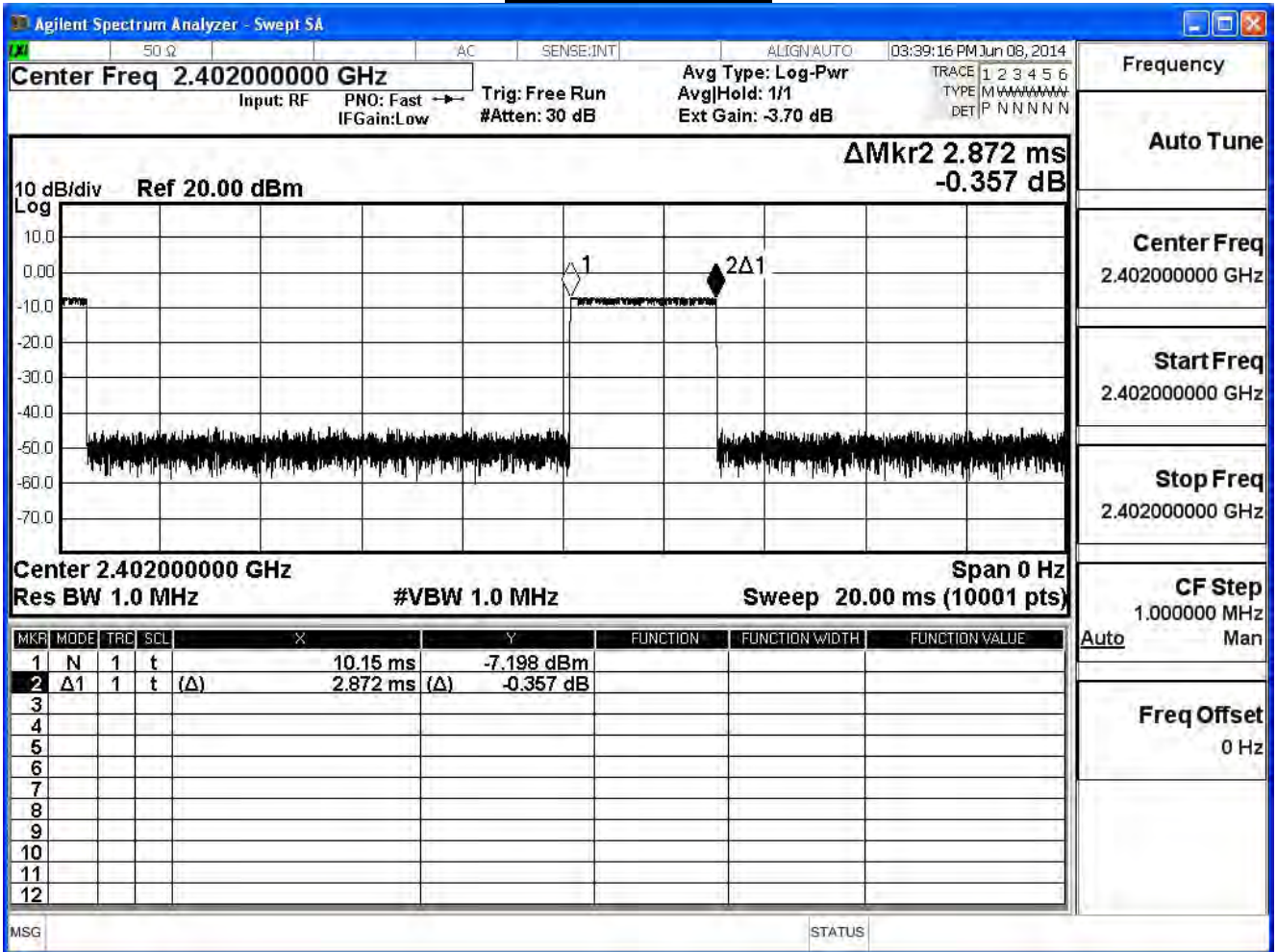

Hop rate-2441MHz

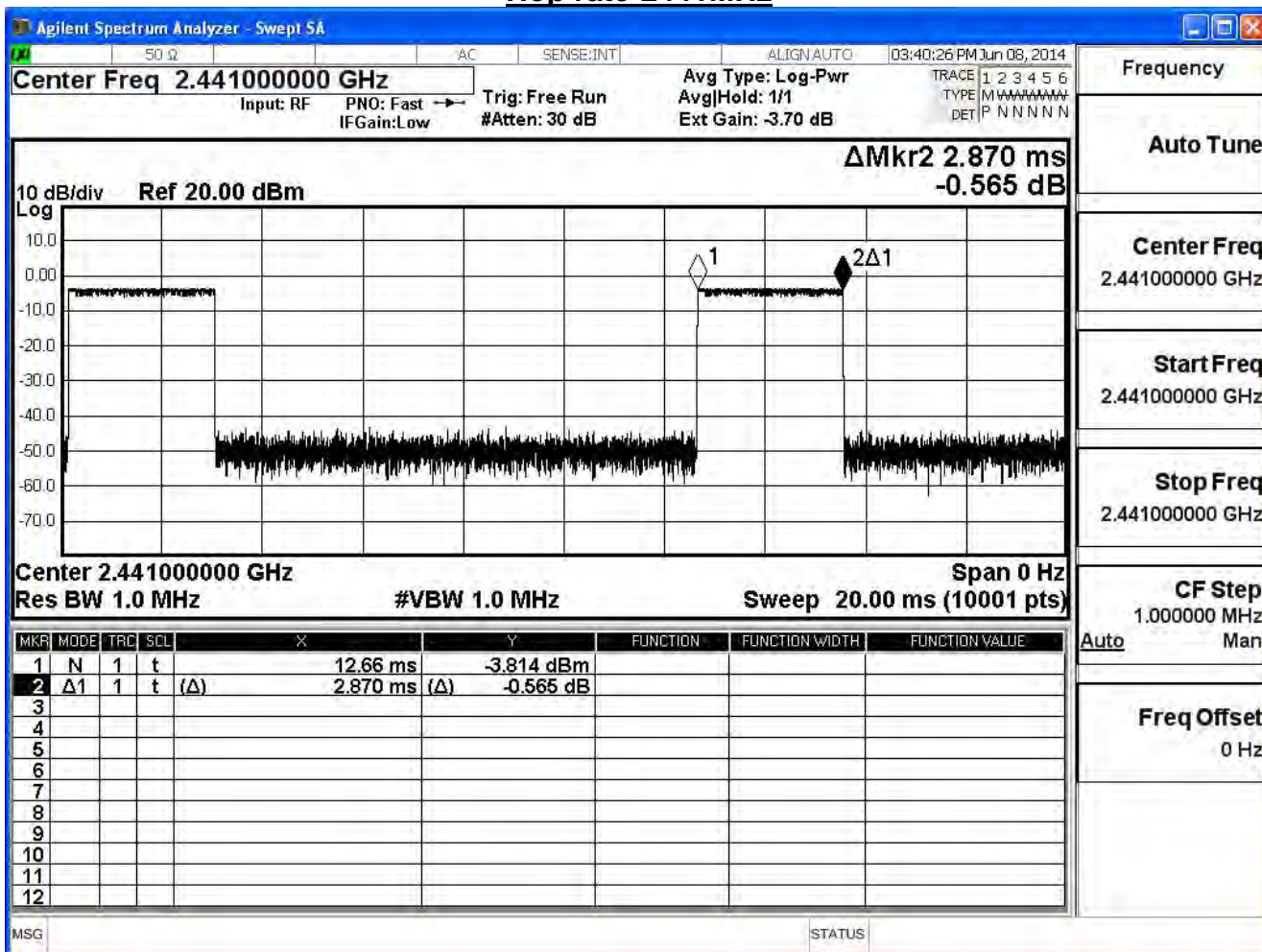

Hop rate-2480MHz

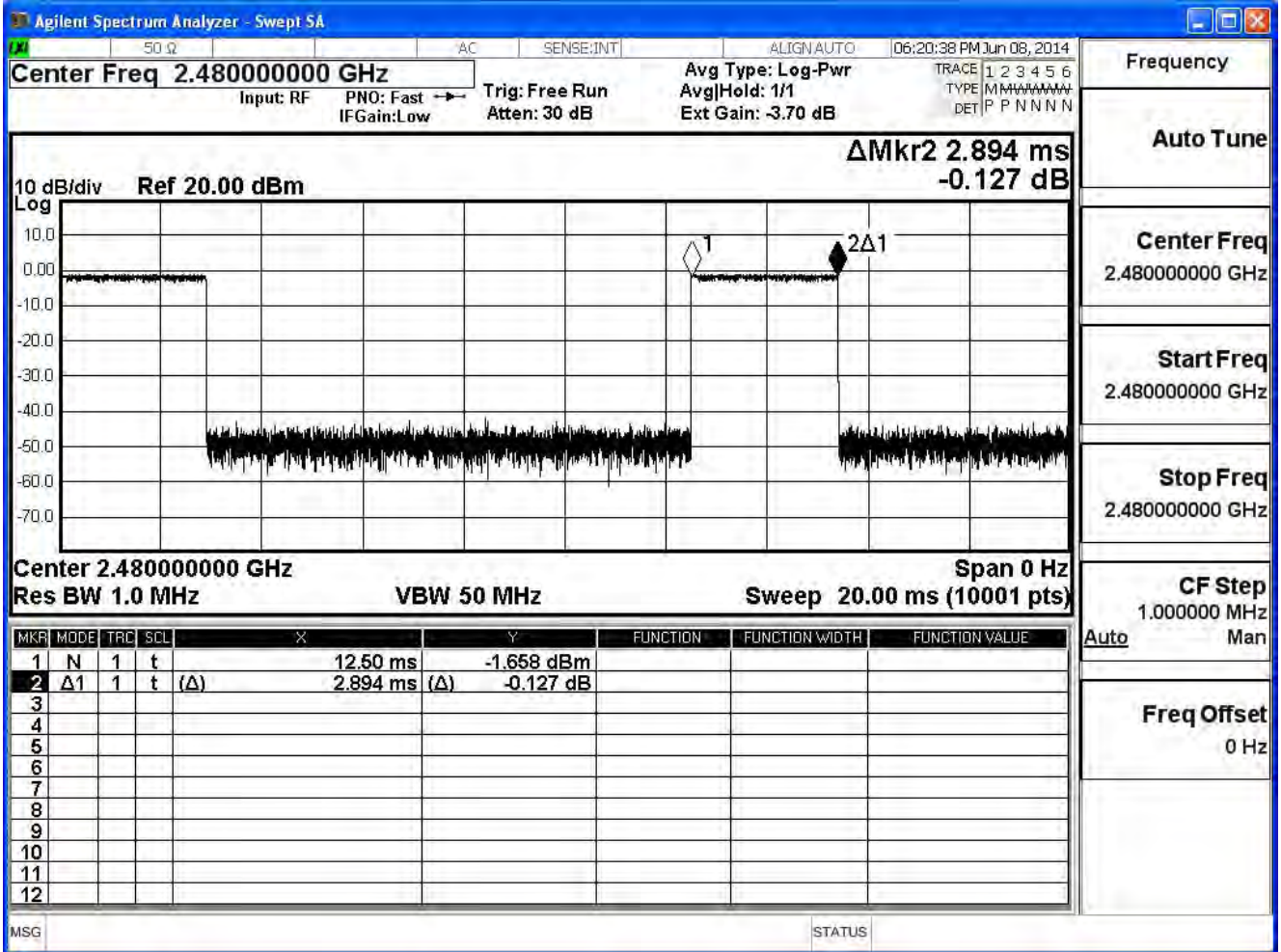

Note: Dwell time = time slot length * hop rate / number of hopping channels * period

Product	SkyCaddie		
Test Item	Dwell Time		
Test Mode	Mode 1: Transmit (Power by PC)		
Date of Test	2014/06/08	Test Site	SR7

8-DQPSK, 3DH5

Occupancy Time of Frequency Hopping System

A) 2402MHz Test Time Period: $0.4 \times 79 = 31.60\text{sec}$, Time slot length : 2.886 ms = 0.002886sec

Dwell Time : $0.002886 \times (266.67/79) \times 31.60 = 0.3078\text{sec}$ ◦

B) 2441MHz Test Time Period: $0.4 \times 79 = 31.60\text{sec}$, Time slot length : 2.892 ms = 0.002892 sec

Dwell Time : $0.002892 \times (266.67/79) \times 31.60 = 0.3084\text{sec}$ ◦

C) 2480MHz Test Time Period: $0.4 \times 79 = 31.60\text{sec}$, Time slot length : 2.886 ms = 0.002886 sec

Dwell Time : $0.002886 \times (266.67/79) \times 31.60 = 0.3078\text{sec}$ ◦

Test Result: The Average Occupancy Time of Each Highest , Middle and Lowest Channel Is Less Than 0.4sec , And Corresponds to The Standard ◦

Hop rate-2402MHz

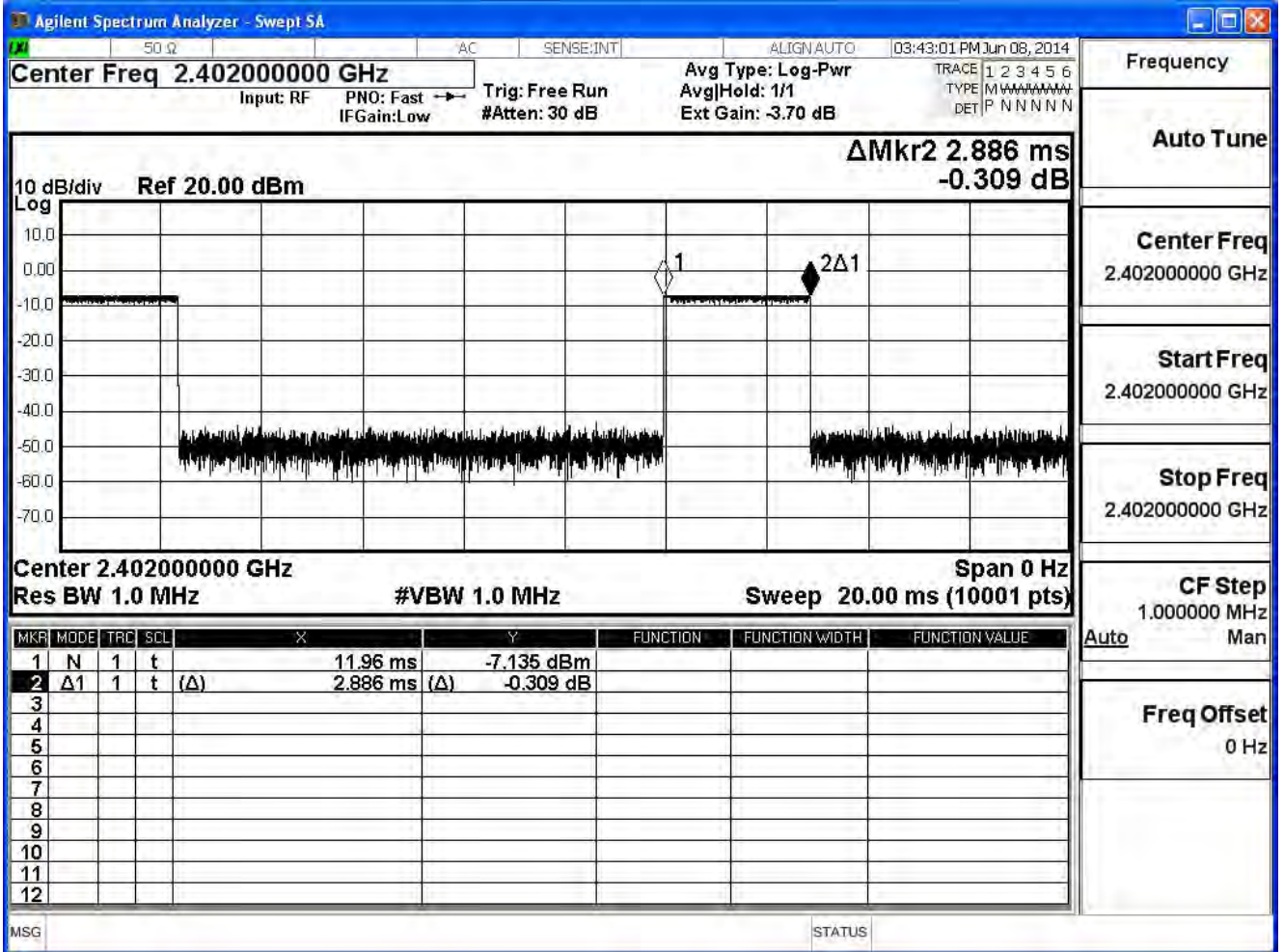

Hop rate-2441MHz

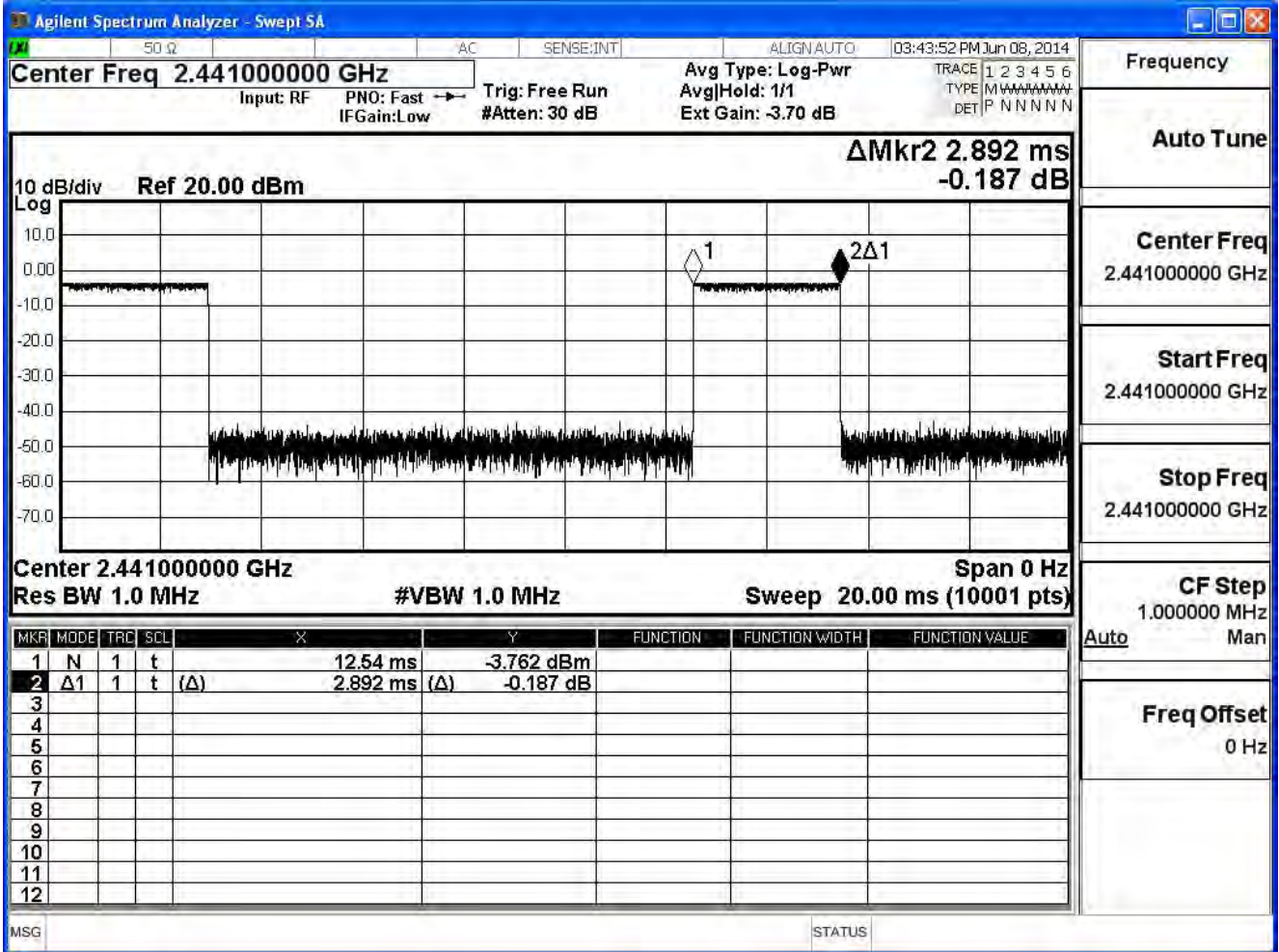

Hop rate-2480MHz

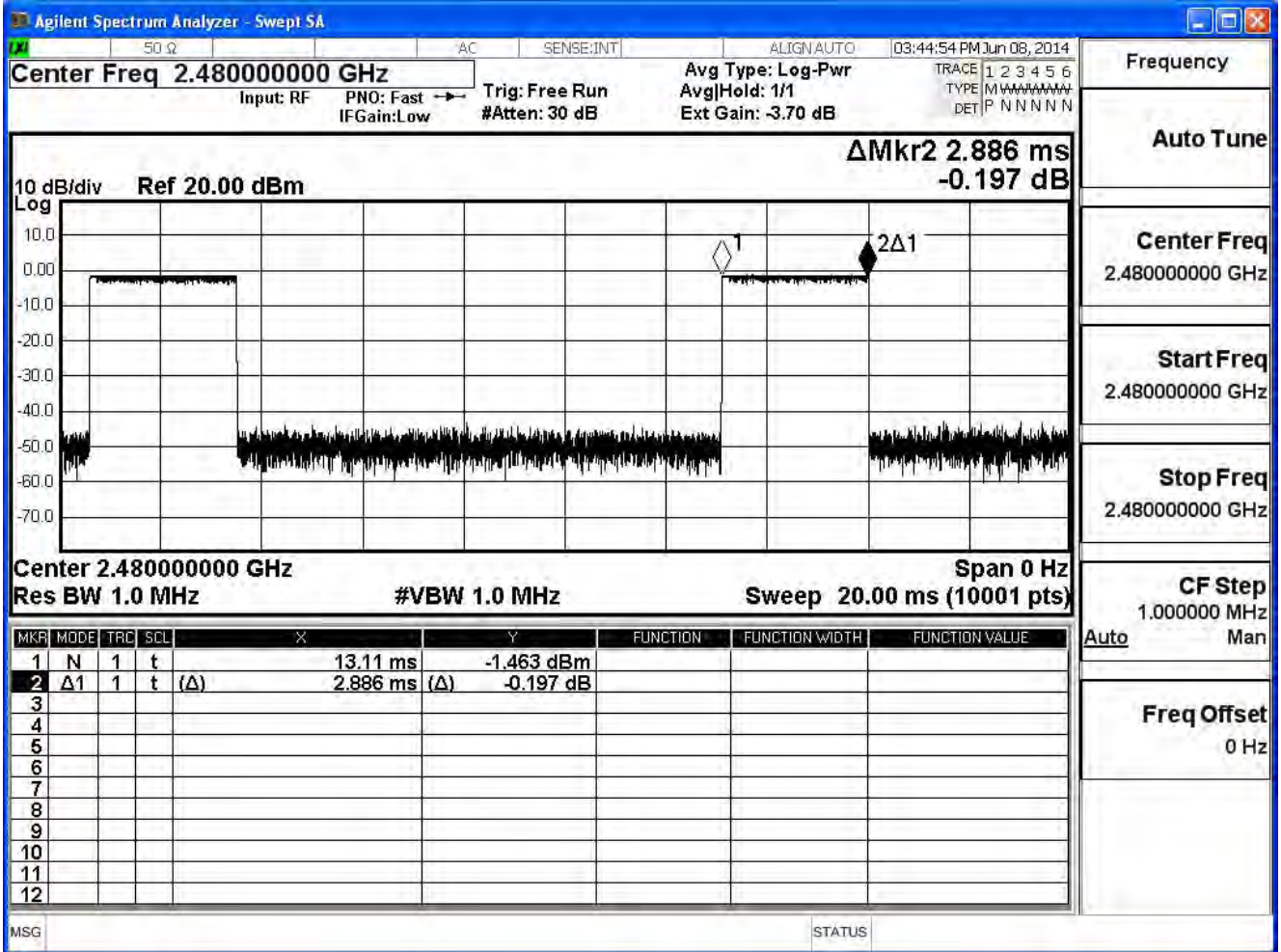

Note: Dwell time = time slot length * hop rate / number of hopping channels * period