



FCC Test Report

Report No.: AGC01585140401FE03

FCC ID : X70KEYLESS042
APPLICATION PURPOSE : Original Equipment
PRODUCT DESIGNATION : Wireless keypad
BRAND NAME : Manaras/Opera
MODEL NAME : KEYLESS042
CLIENT : 914I-0120 Quebec Inc. DBA MANARAS/OPERA
DATE OF ISSUE : Jun.22, 2014
STANDARD(S) : FCC Part 15 Rules
REPORT VERSION : V1.0

Attestation of Global Compliance (Shenzhen) Co., Ltd



CAUTION:

This report shall not be reproduced except in full without the written permission of the test laboratory and shall not be quoted out of context.

Report Revise Record

Report Version	Revise Time	Issued Date	Valid Version	Notes
V1.0	/	Jun.22, 2014	Valid	Original Report

TABLE OF CONTENTS

1. VERIFICATION OF CONFORMITY	4
2. GENERAL INFORMATION	5
2.1. PRODUCT DESCRIPTION.....	5
2.2. RELATED SUBMITTAL(S) / GRANT (S).....	5
2.3. TEST METHODOLOGY.....	5
2.4. SPECIAL ACCESSORIES	5
2.5. EQUIPMENT MODIFICATIONS	5
3. MEASUREMENT UNCERTAINTY.....	6
4. DESCRIPTION OF TEST MODES.....	6
5. SYSTEM TEST CONFIGURATION	6
5.1. EQUIPMENT USED IN EUT SYSTEM	6
5.2. SUMMARY OF TEST RESULTS	6
6. TEST FACILITY	7
7. ANTENNA REQUIREMENT	8
8. PROVISION FOR MOMENTARY OPERATION	9
8.1 MEASUREMENT PROCEDURE	9
8.2 TEST SETUP	9
8.3 TEST RESULT	10
9. AVERAGE FACTOR.....	11
9.1 MEASUREMENT PROCEDURE	11
9.2 TEST SETUP	11
9.3 TEST RESULT	12
10. RADIATED EMISSION	15
10.1. MEASUREMENT PROCEDURE	15
10.2. TEST SETUP	17
10.3. TEST RESULT	18
11. BANDWIDTH	22
11.1. MEASUREMENT PROCEDURE	22
11.2. TEST SETUP	22
11.3. TEST RESULT	23
APPENDIX A: PHOTOGRAPHS OF TEST SETUP	24
APPENDIX B: PHOTOGRAPHS OF EUT	25

1. VERIFICATION OF CONFORMITY

Applicant	914I-0120 Quebec Inc. DBA MANARAS/OPERA
Address	136 Oneida Drive, POINTE-CLAIRE, Quebec, Canada. H9R 1A8
Manufacturer	Capital Prospect Ltd.
Address	1303, B1k B, Veristrong Ind Center, 36 Aupuiwan street, Fotan, HK
Product Designation	Wireless keypad
Brand Name	Manaras/Opera
Test Model	KEYLESSO42
Date of test	Jun.10~ Jun.22,2014
Deviation	None
Condition of Test Sample	Normal
Report Template	AGCRT-US-BR/RF (2013-03-01)

We hereby certify that:

The above equipment was tested by Attestation of Global Compliance (Shenzhen) Co., Ltd. The test data, data evaluation, test procedures, and equipment configurations shown in this report were made in accordance with the procedures given in ANSI C63.4 (2003) and the energy emitted by the sample EUT tested as described in this report is in compliance with radiated emission limits of FCC Rules Part 15.231.

Prepared By

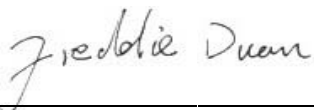
 Freddie Duan Jun.22, 2014

Checked By

 Kidd Yang Jun.22, 2014

Authorized By

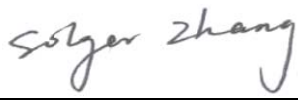
 Solger Zhang Jun.22, 2014

2. GENERAL INFORMATION

2.1. PRODUCT DESCRIPTION

A major technical description of EUT is described as following

Operation Frequency	390MHz
FIELD STRENGTH (3m)	75.14dBuV/m(AV)@3m
Modulation	ASK
Number of channels	1
Hardware Version	N/A
Software Version	N/A
Antenna Designation	Integral antenna
Antenna Gain	0 dBi
Power Supply	DC1.5V by Battery

2.2. RELATED SUBMITTAL(S) / GRANT (S)

This submittal(s) (test report) is intended for **FCC ID: X7OKEYLESSO42** filing to comply with Section 15.231 of the FCC Part 15, Subpart C Rules.

2.3. TEST METHODOLOGY

Both conducted and radiated testing was performed according to the procedures in ANSI C63.4 (2003). Radiated testing was performed at an antenna to EUT distance 3 meters.

2.4. SPECIAL ACCESSORIES

Refer to section 5.1.

2.5. EQUIPMENT MODIFICATIONS

Not available for this EUT intended for grant.

3. MEASUREMENT UNCERTAINTY

Conducted measurement: +/- 2.75dB

Radiated measurement: +/- 3.2dB

4. DESCRIPTION OF TEST MODES

NO.	TEST MODE DESCRIPTION
1	Transmitting mode
<p>Note:</p> <ol style="list-style-type: none"> 1. All the test modes can be supply by AAA battery, only the result of the worst case was recorded in the report, if no other cases. 2. For Radiated Emission, 3axis were chosen for testing for each applicable mode. 3. When start transmitting, the EUT will be deactivated within 5s no matter how long the buttons have been pressed on. 4. All the buttons of the EUT has been tested, and only the worst case was reported. 	

5. SYSTEM TEST CONFIGURATION

5.1. EQUIPMENT USED IN EUT SYSTEM

Item	Equipment	Model No.	ID or Specification	Remark
1	N/A			

5.2. SUMMARY OF TEST RESULTS

FCC RULES	DESCRIPTION OF TEST	RESULT
§15.203	Antenna Requirement	Compliant
§15.231(a)(1)	Periodic operation	Compliant
§15.231(b)	Average Factor	Compliant
§15.231(b) & §15.209	Field Strength of Fundamental and Spurious Emission	Compliant
§15.231(c)	Bandwidth	Compliant

6. TEST FACILITY

Site	Attestation of Global Compliance (Shenzhen) Co., Ltd
Location	2/F., Building 2, No.1-No.4, Chaxi Sanwei Technical Industrial Park, Gushu, Xixiang, Bao'an District, Shenzhen, Guangdong, China
Description	The test site is constructed and calibrated to meet the FCC requirements in documents ANSI C63.4:2003.
FCC Registration Number	259865

ALL TEST EQUIPMENT LIST

Description	Manufacturer	Model	S/N	Cal. Date	Cal. Due
RF attenuator	N/A	RFA20db	68	N/A	N/A
Spectrum Analyzer	Agilent	E4440A	US41421290	07/17/2013	07/16/2014
Amplifier	EM	EM30180	0607030	02/27/2014	02/26/2015
Horn Antenna	EM	EM-AH-10180	67	04/19/2014	04/18/2015
Biological Antenna	A.H. Systems Inc.	SAS-521-4	26	06/06/2014	06/05/2015
Loop Antenna	Daze	ZN30900N	SEL0097	07/17/2013	07/16/2014
Isolation Transformer	LETEAC	LTBK	--	07/17/2013	07/16/2014

7. ANTENNA REQUIREMENT

According to §15.203, an intentional radiator shall be designed to ensure that no antenna other than that furnished by the responsible party shall be used with the device.

The EuT has Integral antenna , which accordance to the above sections, is considered sufficient to comply with the provisions of these sections. Please see EuT photo for details.

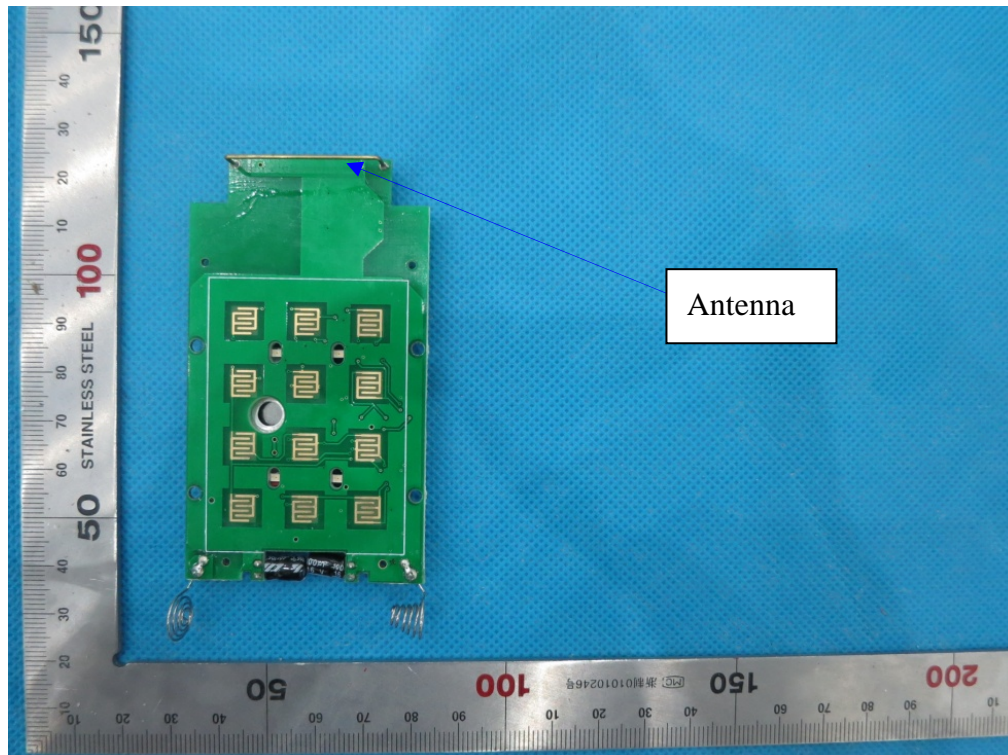

The requirements of section 15.203 are **FULFILLED**.

8. PROVISION FOR MOMENTARY OPERATION

8.1 MEASUREMENT PROCEDURE

1. Set the parameters of SPA as below:
Centre frequency = Operation Frequency
RBW=VBW=1MHz
Span: 0Hz
Sweep time: 10S
2. Set the EUT to transmit by manually operated. Use the "View" function of SPA to find the transmission time of being released.
3. Record the data and Reported.

8.2 TEST SETUP

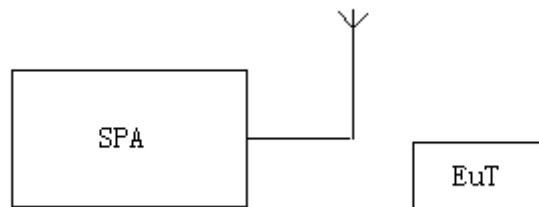

8.3 TEST RESULT

The time of stopping transmission after switch releasing (s)	Limit (s)
1.36	5.00

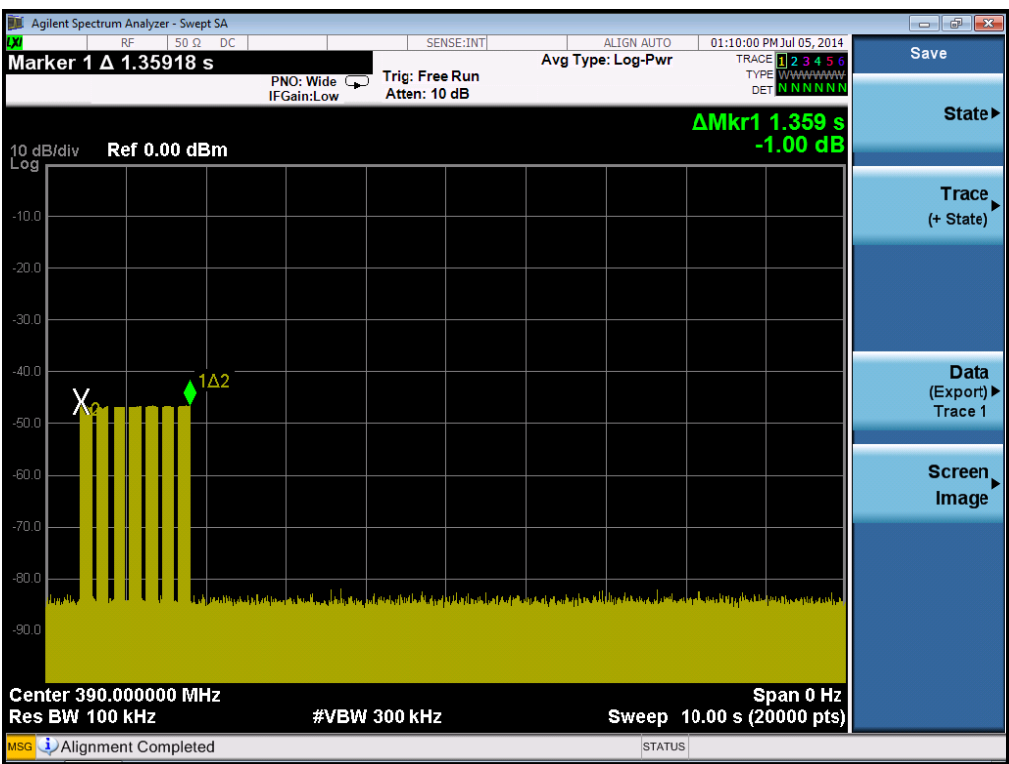

RESULT: PASS

9. AVERAGE FACTOR

9.1 MEASUREMENT PROCEDURE

1. Set the parameters of SPA as below:
Centre frequency = Operation Frequency
RBW=VBW=1MHz
Span: 0Hz
Sweep time: more than two pulse trains or more than each type of pulse occupancy time
2. Set the EUT to transmit by manually operated. Use the "Delta mark" function of SPA to find the period time between two pulse trains and each type of pulse occupancy time.
3. Record the plots and Reported.

9.2 TEST SETUP

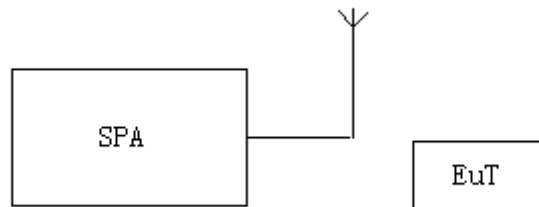

9.3 TEST RESULT

Duty Cycle:	$(4\text{ms} \cdot 2 + 1.32\text{ms} \cdot 19 + 0.6\text{ms} \cdot 25) / 100\text{ms} = 0.4808$
Duty Cycle Correction Factor:	$20\log(0.4808) = -6.36$

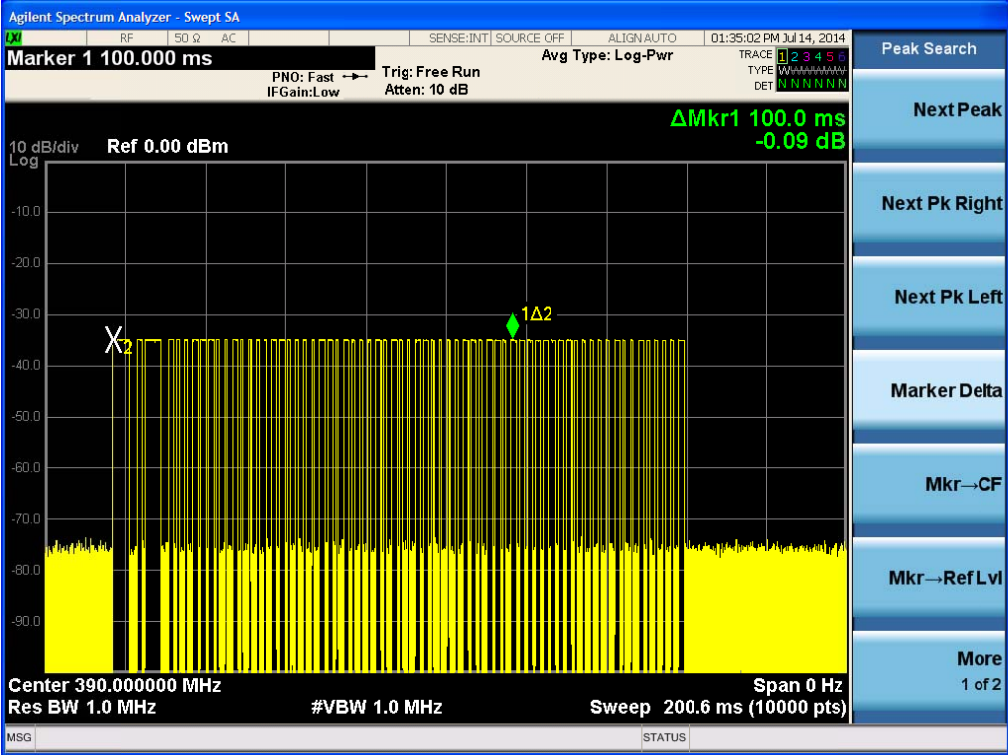
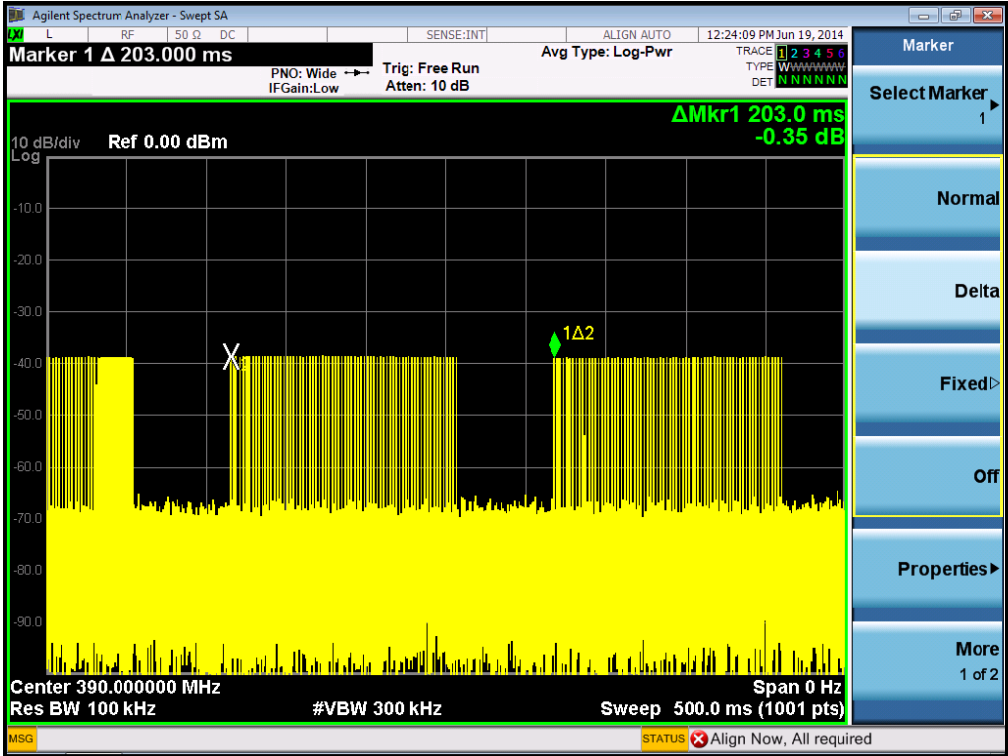

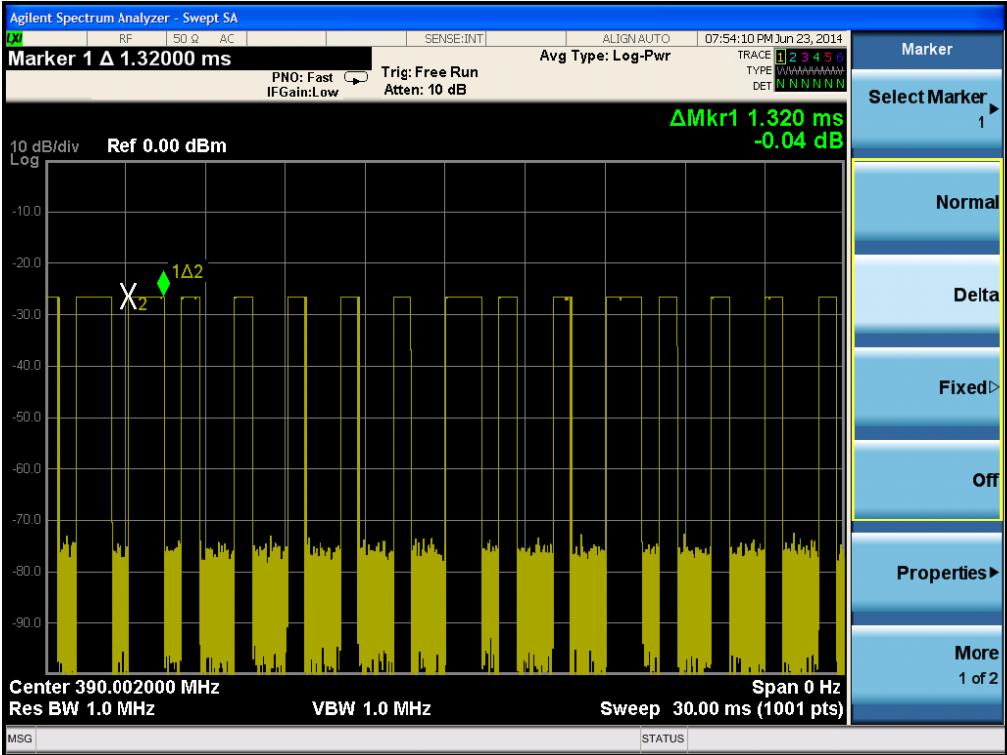
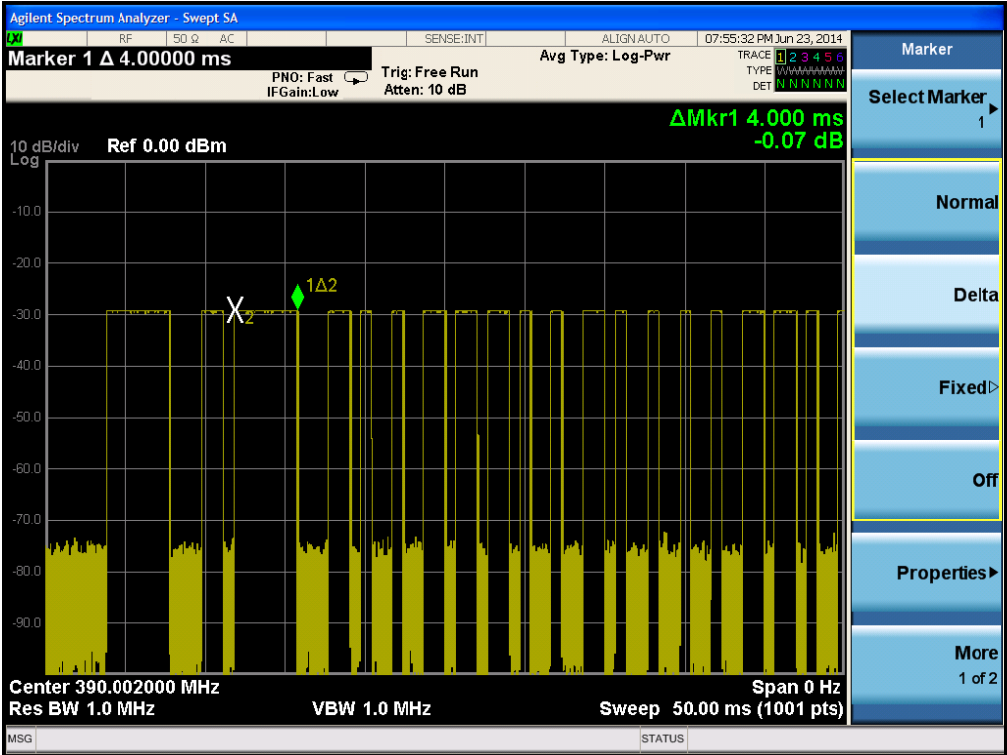

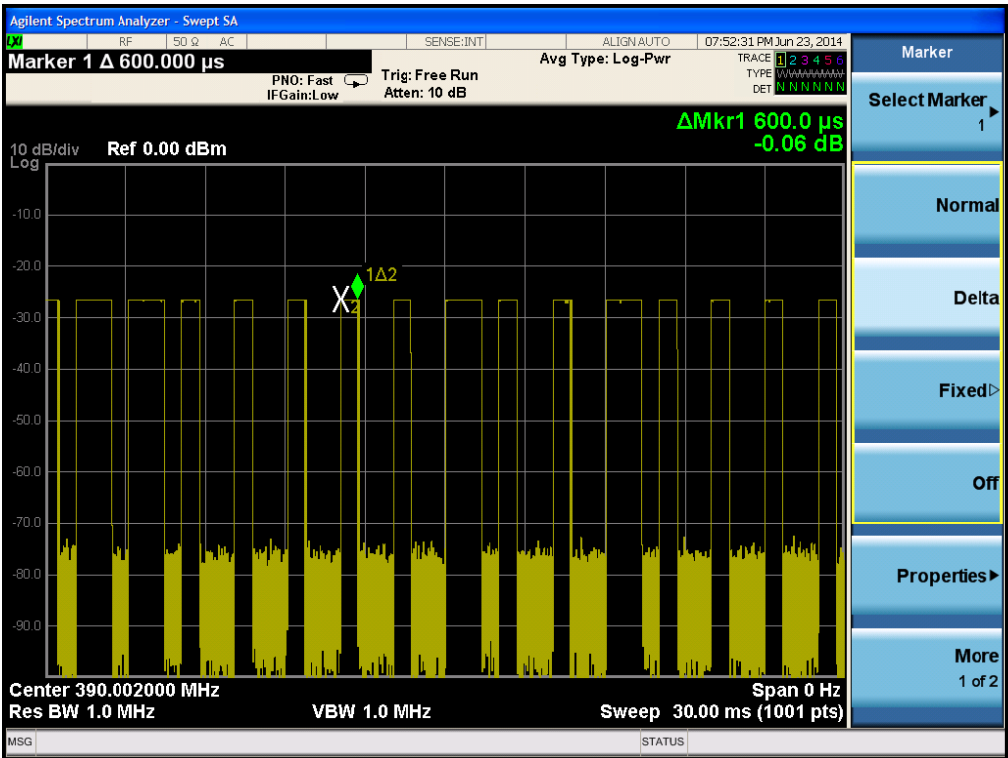

10. RADIATED EMISSION

10.1. MEASUREMENT PROCEDURE

1. Configure the EUT according to ANSI C63.4. The EUT was placed on the top of the turntable 0.8 meter above ground. The phase center of the receiving antenna mounted on the top of a height-variable antenna tower was placed 3 meters far away from the turntable.
2. Power on the EUT and all the supporting units. The turntable was rotated by 360 degrees to determine the position of the highest radiation.
3. The height of the broadband receiving antenna was varied between one meter and four meters above ground to find the maximum emissions field strength of both horizontal and vertical polarization.
4. For each suspected emissions, the antenna tower was scan (from 1 M to 4 M) and then the turntable was rotated (from 0 degree to 360 degrees) to find the maximum reading.
5. Set the test-receiver system to Peak or CISPR quasi-peak Detect Function with specified bandwidth under Maximum Hold Mode.
6. For emissions below 1GHz, use 120KHz RBW and $VBW \geq 3RBW$ for QP reading.
7. For emissions above 1GHz, use 1MHz VBW and RBW for peak reading. Then 1MHz RBW and 10Hz VBW for average reading in spectrum analyzer.
8. When the radiated emissions limits are expressed in terms of the average value of the emissions, and pulsed operation is employed, the measurement field strength shall be determined by averaging over one complete pulse train, including blanking intervals, as long as the pulse train does not exceed 0.1 seconds. As an alternative (provided the transmitter operates for longer than 0.1 seconds) or in cases where the pulse train exceeds 0.1 seconds, the measured field strength shall be determined from the average absolute voltage during a 0.1 second interval during which the field strength is at its maximum values.
9. If the emissions level of the EUT in peak mode was 3 dB lower than the average limit specified, then testing will be stopped and peak values of EUT will be reported, otherwise, the emissions which do not have 3 dB margin will be repeated one by one using the quasi-peak method for below 1GHz.
10. For testing above 1GHz, the emissions level of the EUT in peak mode was lower than average limit (that means the emissions level in peak mode also complies with the limit in average mode), then testing will be stopped and peak values of EUT will be reported, otherwise, the emissions will be measured in average mode again and reported.
11. In case the emission is lower than 30MHz, loop antenna has to be used for measurement and the recorded data should be QP measured by receiver. High - Low scan is not required in this case.
12. Only the worst case is reported.

The following table is the setting of spectrum analyzer and receiver.

Spectrum Parameter	Setting
Start ~Stop Frequency	9KHz~150KHz/RBW 200Hz for QP
Start ~Stop Frequency	150KHz~30MHz/RBW 9KHz for QP
Start ~Stop Frequency	30MHz~1000MHz/RBW 120KHz for QP
Start ~Stop Frequency	1GHz~26.5GHz 1MHz/1MHz for Peak, 1MHz/10Hz for Average

Receiver Parameter	Setting
Start ~Stop Frequency	9KHz~150KHz/RBW 200Hz for QP
Start ~Stop Frequency	150KHz~30MHz/RBW 9KHz for QP
Start ~Stop Frequency	30MHz~1000MHz/RBW 120KHz for QP

10.2. TEST SETUP

RADIATED EMISSION TEST SETUP BELOW 30MHz

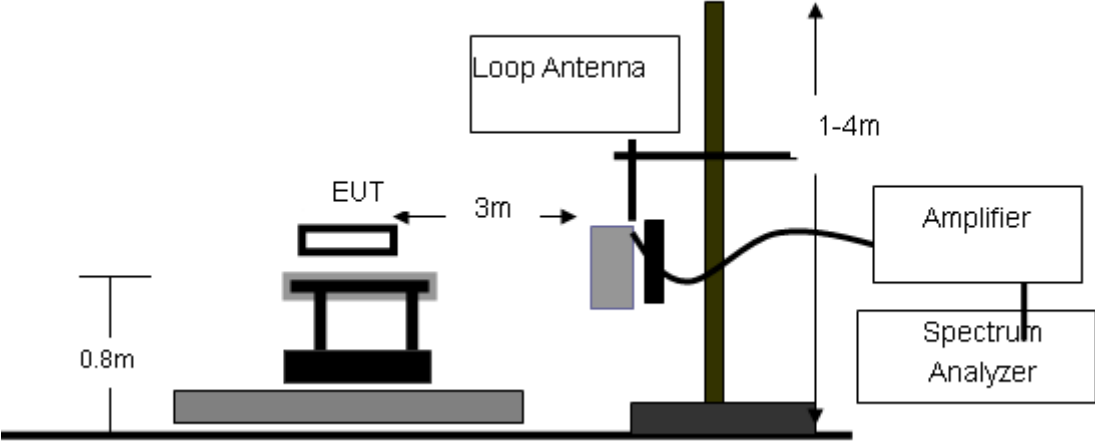

RADIATED EMISSION TEST SETUP 30MHz-1000MHz

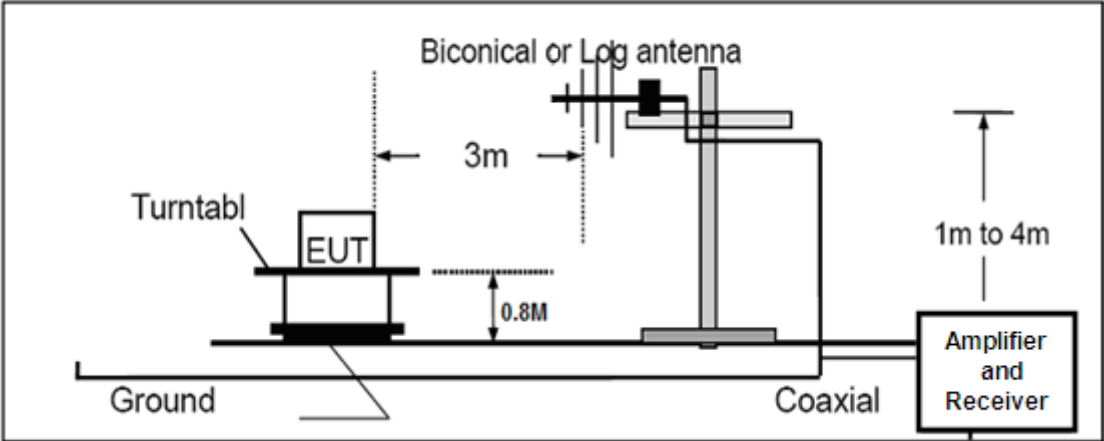

RADIATED EMISSION TEST SETUP ABOVE 1000MHz

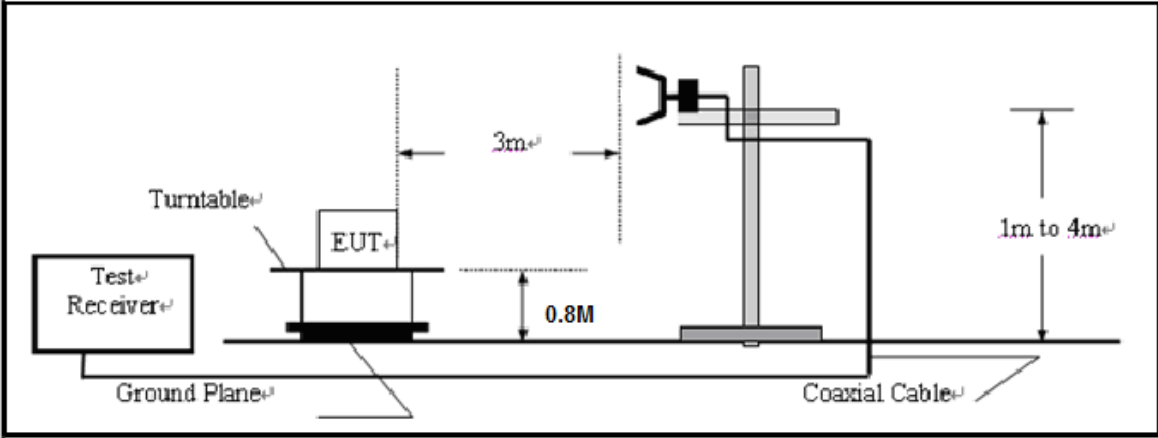

10.3. TEST RESULT

RADIATED EMISSION BELOW 30MHZ

No emission found between lowest internal used/generated frequencies to 30MHz.

RADIATED EMISSION BELOW 1GHZ-Horizontal

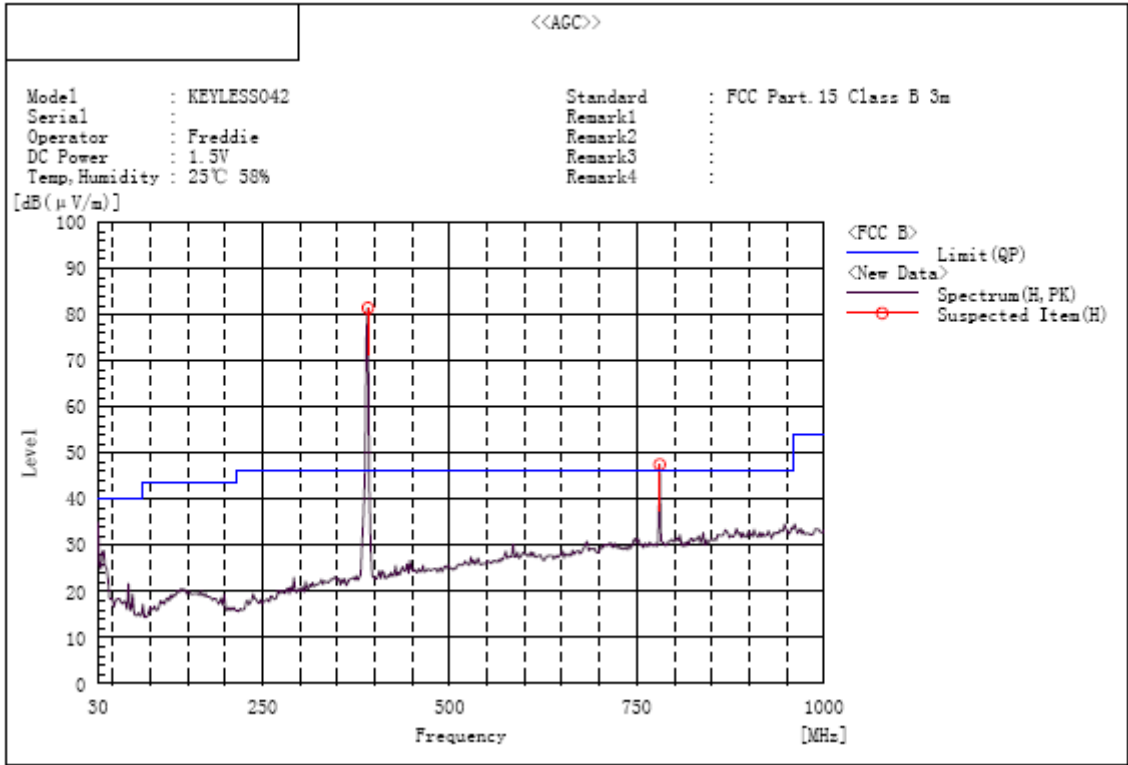

Frequency MHz	Polarization	Reading dB(uV)	Factor dB(1/m)	PK Level dB(uV/m)	Limit dB(uV/m) PK	Margin dB PK	Pass/Fail	Detector	Remark
390.840	H	62.9	18.6	81.5	99.2	-17.7	Pass	PK	Fundamental
780.780	H	22.0	25.6	47.6	79.2	-31.6	Pass	PK	Harmonic

Frequency MHz	Polarization	PK Level dB(uV/m)	AV Factor dB	AV Level dB(uV/m)	Limit dB(uV/m) AV	Margin dB PK	Pass/Fail	Detector	Remark
390.840	H	81.5	-6.36	75.14	79.2	-4.06	Pass	AV	Fundamental
780.780	H	47.6	-6.36	41.24	59.2	-17.96	Pass	AV	Harmonic

RADIATED EMISSION BELOW 1GHZ-Vertical

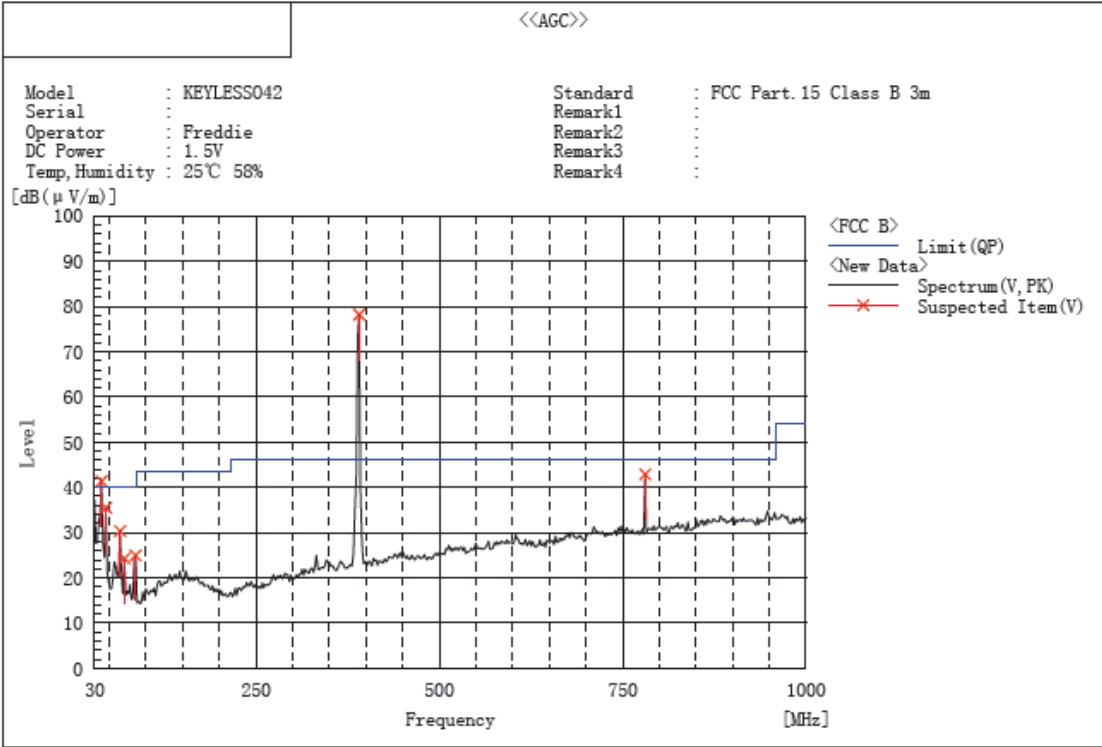

Frequency MHz	Polarization	Reading dB(uV)	Factor dB (1/m)	PK Level dB(uV/m)	Limit dB(uV/m) PK	Margin dB PK	Pass/Fail	Detector	Remark
390.840	V	59.7	18.6	78.3	99.2	-20.9	Pass	PK	Fundamental
780.780	V	17.3	25.6	42.9	79.2	-36.3	Pass	PK	Harmonic

Frequency MHz	Polarization	Level dB(uV/m)	AV Factor dB	AV Level dB(uV/m)	Limit dB(uV/m) AV	Margin dB PK	Pass/Fail	Detector	Remark
390.840	V	78.3	-6.36	71.94	79.2	-7.26	Pass	AV	Fundamental
780.780	V	42.9	-6.36	36.54	59.2	-22.66	Pass	AV	Harmonic

RESULT: PASS

Note: 1. Factor=Antenna Factor + Cable loss, Margin=Measurement-Limit.

2. AV Level = PK Level + Duty cycle correction factor

3. The "Factor" value can be calculated automatically by software of measurement system.

RADIATED EMISSION ABOVE 1GHZ (1-10th Harmonics) -Horizontal

Frequency MHz	Polarization	Reading dBm	Factor dB (1/m)	PK Level dBuV/m	Level dBuV/m PK	Margin dB PK	Pass/Fail	Detector	Remark
2731.000	H	55.2	1.8	57.0	74.0	-17.0	Pass	PK	Harmonic
1171.000	H	54.8	-6.4	48.4	74.0	-25.6	Pass	PK	Harmonic
2341.000	H	49.4	-1.0	48.4	79.2	-30.8	Pass	PK	Harmonic
1951.000	H	49.4	-2.8	46.6	79.2	-32.6	Pass	PK	Harmonic
Frequency MHz	Polarization	PK Level dB(uV/m)	AV Factor dB	AV Level dBuV/m	Level dBuV/m AV	Margin dB AV	Pass/Fail	Detector	Remark
2731.000	H	57.0	-6.36	50.64	54.0	-3.36	Pass	AV	Harmonic
1171.000	H	48.4	-6.36	42.04	54.0	-11.96	Pass	AV	Harmonic
2341.000	H	48.4	-6.36	42.04	59.2	-17.16	Pass	AV	Harmonic
1951.000	H	46.6	-6.36	40.24	59.2	-18.96	Pass	AV	Harmonic

RESULT: PASS

RADIATED EMISSION ABOVE 1GHZ (1-10th Harmonics) -Vertical

Frequency MHz	Polarization	Level dB(uV/m)	Factor dB (1/m)	Level dBm	Limit dBm PK	Margin dB PK	Pass/Fail	Detector	Remark
1171.000	V	60.5	-6.4	54.1	74.0	-19.9	Pass	PK	Harmonic
1951.000	V	48.4	-2.8	45.6	79.2	-33.6	Pass	PK	Harmonic
2341.000	V	49.3	-1.0	48.3	79.2	-30.9	Pass	PK	Harmonic
2731.000	V	50.8	1.8	52.6	74.0	-21.4	Pass	PK	Harmonic
3121.000	V	48.1	3.8	51.9	79.2	-27.3	Pass	PK	Harmonic
Frequency MHz	Polarization	Level dB(uV/m)	AV Factor dB	Level dBuV/m	Level dBuV/m AV	Margin dB AV	Pass/Fail	Detector	Remark
1171.000	V	54.1	-6.36	47.74	54.0	-6.26	Pass	AV	Harmonic
1951.000	V	45.6	-6.36	39.24	59.2	-19.96	Pass	AV	Harmonic
2341.000	V	48.3	-6.36	41.94	59.2	-17.26	Pass	AV	Harmonic
2731.000	V	52.6	-6.36	46.24	54.0	-7.76	Pass	AV	Harmonic
3121.000	V	51.9	-6.36	45.54	59.2	-13.66	Pass	AV	Harmonic

Note: Other emissions have 20dB margin. No recording in the test report.

Factor=Antenna Factor + Cable loss - Amplifier gain, Margin=Measurement-Limit.

The "Factor" value can be calculated automatically by software of measurement system.

RESULT: PASS

11. BANDWIDTH

11.1. MEASUREMENT PROCEDURE

1. Set the parameters of SPA as below:
Centre frequency = Operation Frequency
RBW=10KHz
VBW=30KHz
Span: 500KHz
Sweep time: Auto
2. Set the EUT to continue transmitting mode. Allow the trace to stabilize. Use the “N dB down” function of SPA to define the bandwidth.
3. Record the plots and Reported.

11.2. TEST SETUP

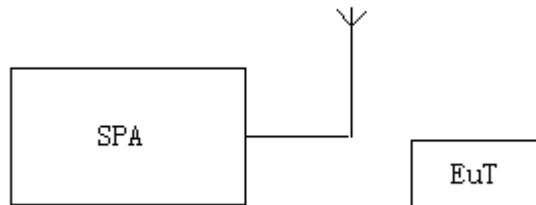

11.3. TEST RESULT

OBW	LIMIT	RESULT
49.3KHz	975.0KHz	Pass
Note: Limit= Operation Frequency $\times 0.25\%$		

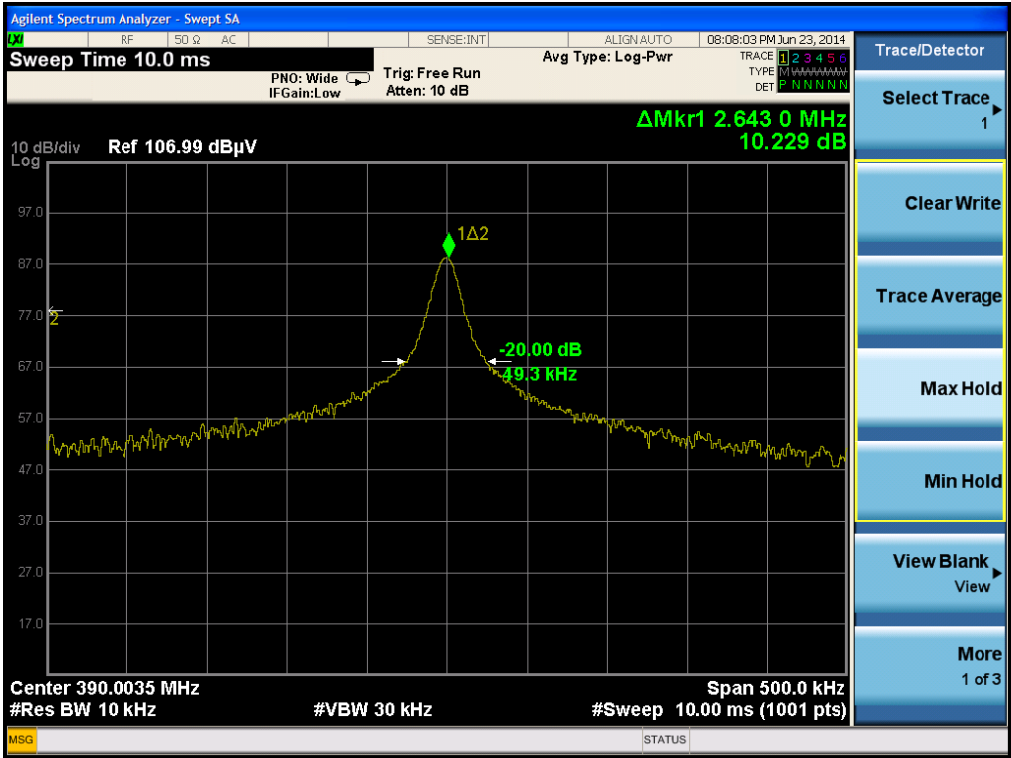

APPENDIX A: PHOTOGRAPHS OF TEST SETUP

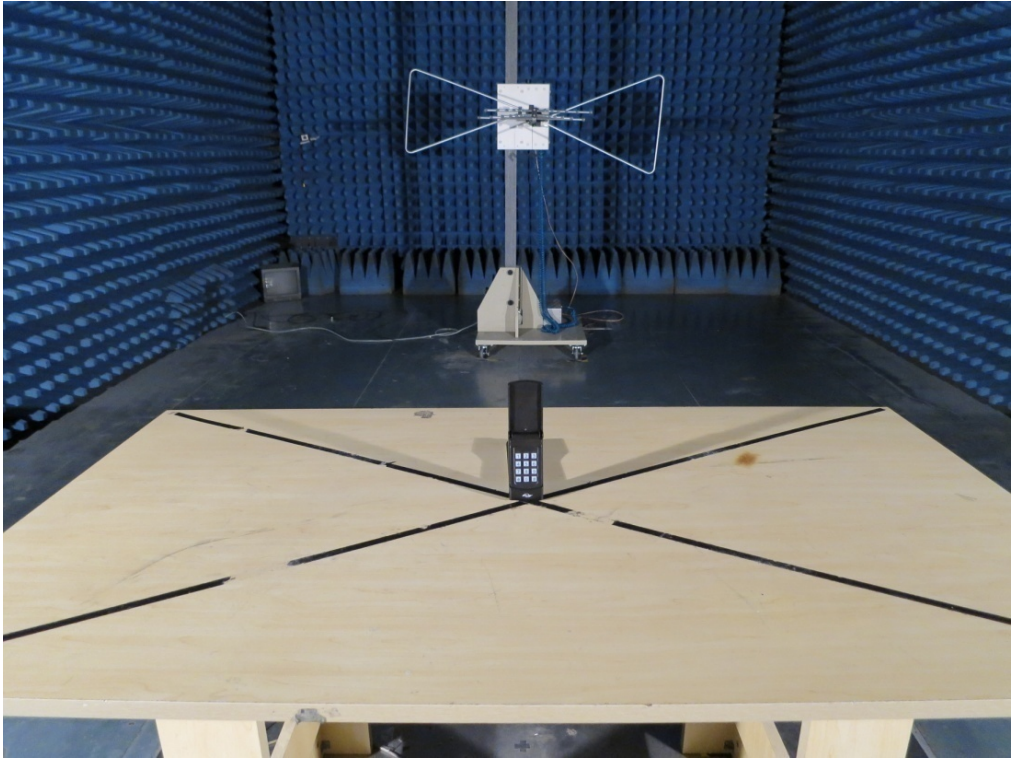

FCC RADIATED EMISSION TEST SETUP

APPENDIX B: PHOTOGRAPHS OF EUT
TOTAL VIEW OF EUT



TOP VIEW OF EUT



BOTTOM VIEW OF EUT



FRONT VIEW OF EUT

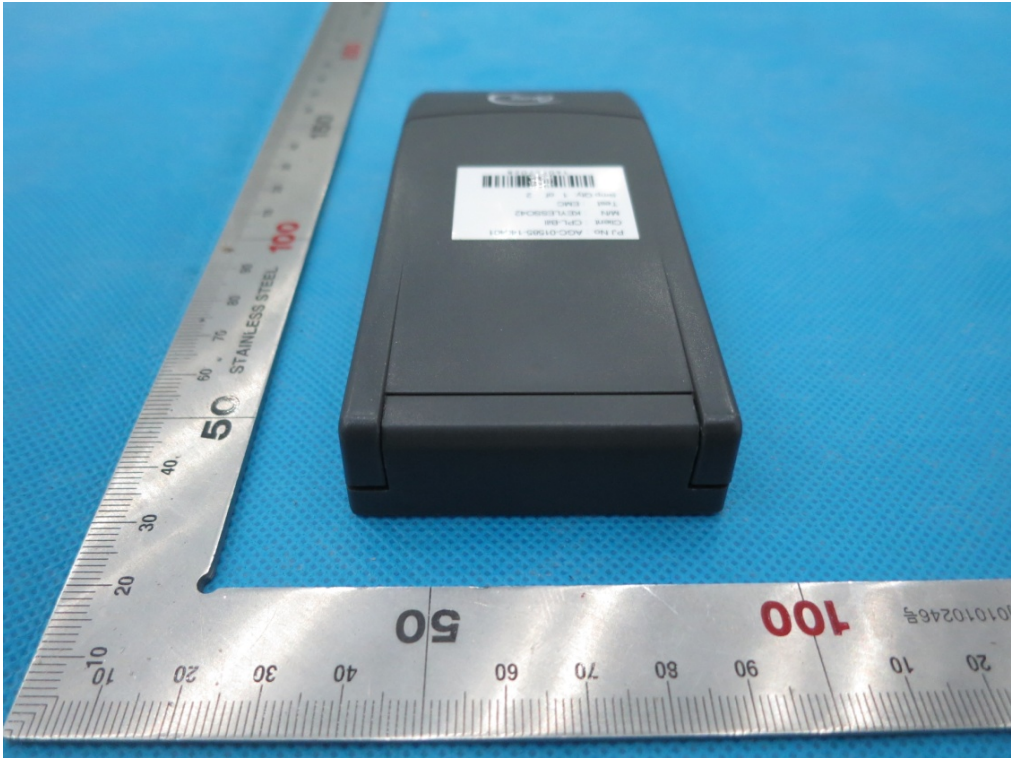

BACK VIEW OF EUT



LEFT VIEW OF EUT



RIGHT VIEW OF EUT



INTERNAL VIEW OF EUT-1

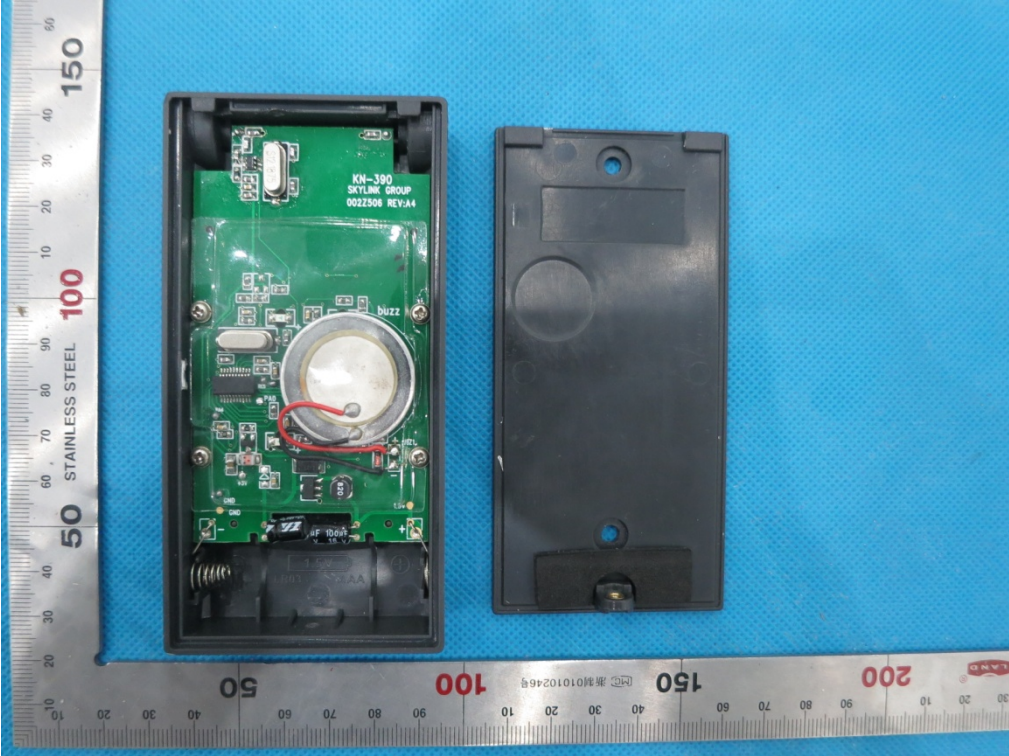

INTERNAL VIEW OF EUT-2



INTERNAL VIEW OF EUT-3

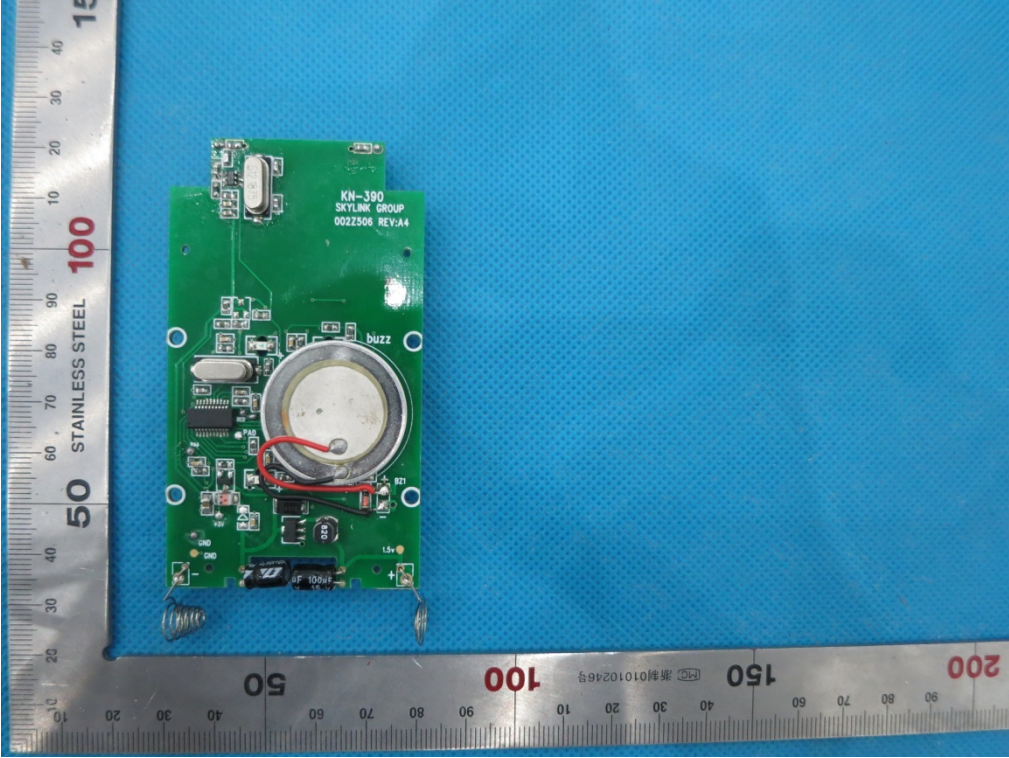

INTERNAL VIEW OF EUT-4

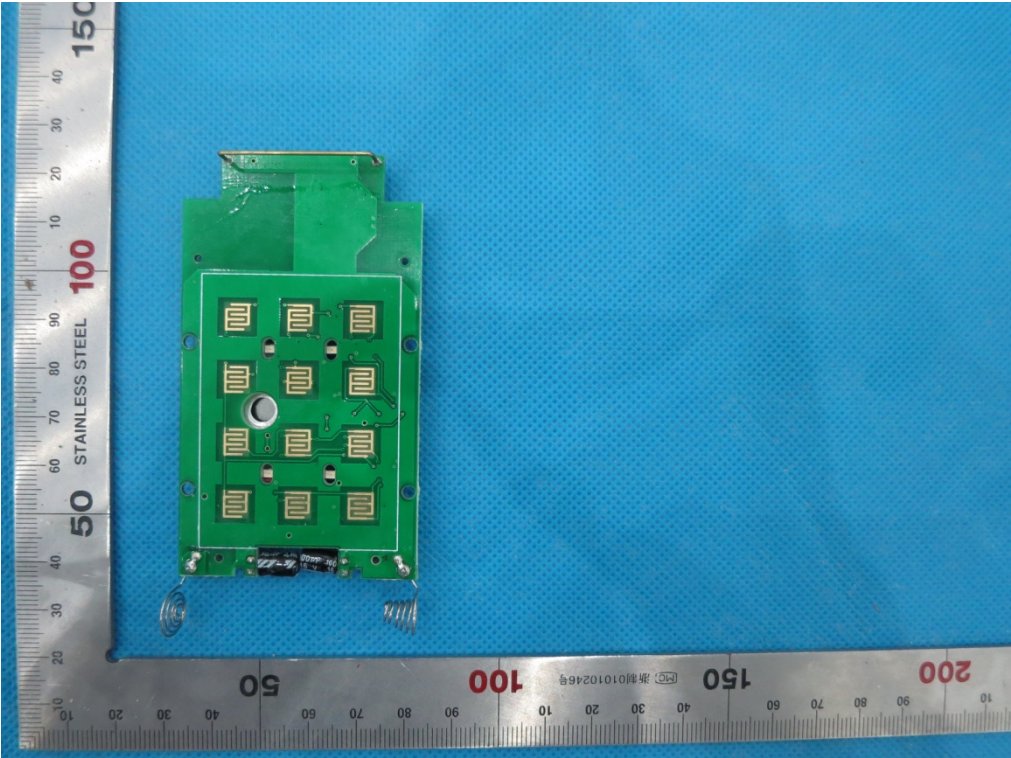

INTERNAL VIEW OF EUT-5

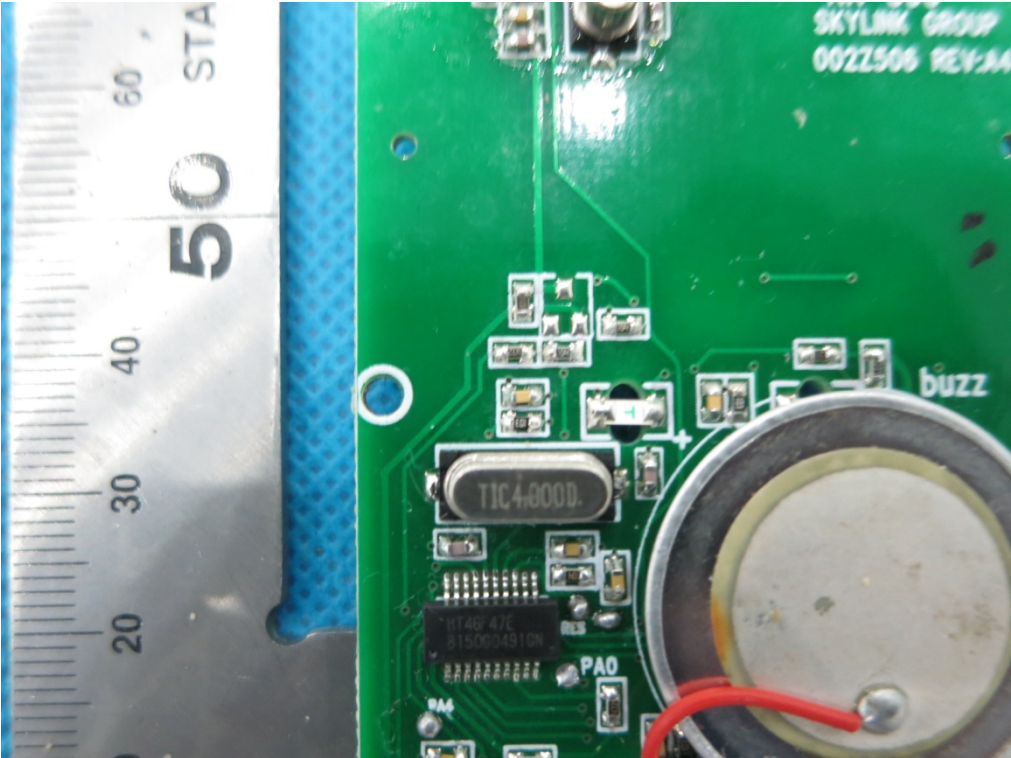

INTERNAL VIEW OF EUT-6

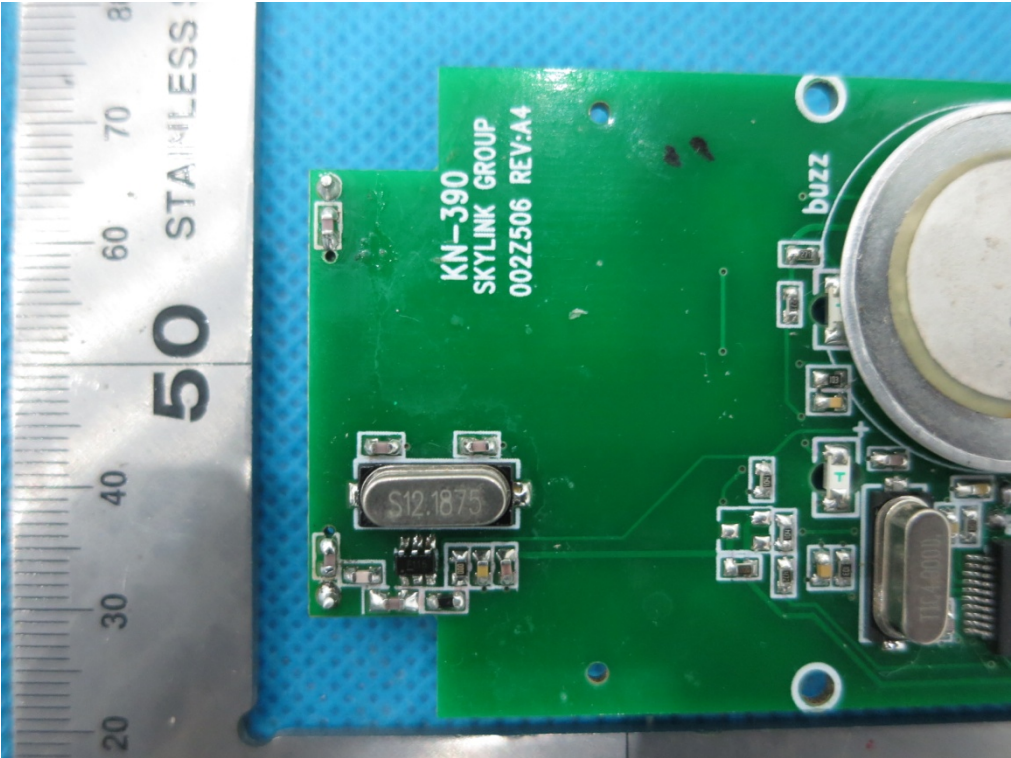

----END OF REPORT----