



**FCC CFR47 PART 15 SUBPART C  
INDUSTRY CANADA RSS-210 ISSUE 8**

**CERTIFICATION TEST REPORT**

**FOR**

**2400 – 2483.5 MHZ TRANSCEIVER**

**MODEL NUMBER: A8520E24A91 and A8520E24C91\***

**FCC ID: X7J-A10051702  
IC: 8975A-A10051702**

**REPORT NUMBER: 11U13980-1, Revision A**

**ISSUE DATE: FEBRUARY 8, 2012**

*Prepared for*  
**ANAREN, INC.**  
**6635 KIRKVILLE ROAD**  
**EAST SYRACUSE, NEW YORK, 13057-9600, U.S.A.**

*Prepared by*  
**COMPLIANCE CERTIFICATION SERVICES (UL CCS)**  
**47173 BENICIA STREET**  
**FREMONT, CA 94538, U.S.A.**  
**TEL: (510) 771-1000**  
**FAX: (510) 661-0888**

\*For model differences please refer to details under section 5.2



**NVLAP LAB CODE 200065-0**

Revision History

<u>Rev.</u>	<u>Issue Date</u>	<u>Revisions</u>	<u>Revised By</u>
---	01/04/12	Initial Issue	F. Ibrahim
A	02/08/12	Revised typos on report and updated description for Maximum Output power	A. Zaffar

## TABLE OF CONTENTS

<b>1. ATTESTATION OF TEST RESULTS</b>	<b>4</b>
<b>2. TEST METHODOLOGY</b>	<b>5</b>
<b>3. FACILITIES AND ACCREDITATION</b>	<b>5</b>
<b>4. CALIBRATION AND UNCERTAINTY</b>	<b>5</b>
4.1. MEASURING INSTRUMENT CALIBRATION	5
4.2. SAMPLE CALCULATION	5
4.3. MEASUREMENT UNCERTAINTY	6
<b>5. EQUIPMENT UNDER TEST</b>	<b>7</b>
5.1. DESCRIPTION OF EUT	7
5.2. MANUFACTURER'S DESCRIPTION OF MODEL DIFFERENCES	7
5.3. MAXIMUM OUTPUT POWER	7
5.4. DESCRIPTION OF AVAILABLE ANTENNAS	7
5.5. SOFTWARE AND FIRMWARE	7
5.6. WORST-CASE CONFIGURATION AND MODE	7
5.7. DESCRIPTION OF TEST SETUP	8
<b>6. TEST AND MEASUREMENT EQUIPMENT</b>	<b>10</b>
<b>7. ANTENNA PORT TEST RESULTS</b>	<b>11</b>
7.1.1. 6 dB BANDWIDTH	11
7.1.2. 99% BANDWIDTH	14
7.1.3. OUTPUT POWER	17
7.1.4. AVERAGE POWER	18
7.1.5. POWER SPECTRAL DENSITY	19
7.1.6. CONDUCTED SPURIOUS EMISSIONS	22
<b>8. RADIATED TEST RESULTS</b>	<b>26</b>
8.1. LIMITS AND PROCEDURE	26
8.2. TRANSMITTER ABOVE 1 GHz	27
8.3. WORST-CASE BELOW 1 GHz	34
8.4. RX SPURIOUS EMISSIONS ABOVE 1 GHz	37
<b>9. AC POWER LINE CONDUCTED EMISSIONS</b>	<b>38</b>
<b>10. MAXIMUM PERMISSIBLE EXPOSURE</b>	<b>42</b>
<b>11. SETUP PHOTOS</b>	<b>46</b>

# 1. ATTESTATION OF TEST RESULTS

**COMPANY NAME:** ANAREN, INC  
6635 KIRKVILLE ROAD  
EAST SYRACUSE, NY, 13057, U.S.A.

**EUT DESCRIPTION:** 2400 – 2483.5 MHZ TRANSCEIVER

**MODEL:** A8520E24A91 and A8520E24C91

**SERIAL NUMBER:** Unit 01

**DATE TESTED:** OCTOBER 05 - DECEMBER 16, 2011

APPLICABLE STANDARDS	
STANDARD	TEST RESULTS
CFR 47 Part 15 Subpart C	Pass
INDUSTRY CANADA RSS-210 Issue 8 Annex 8	Pass
INDUSTRY CANADA RSS-GEN Issue 3	Pass

Compliance Certification Services, Inc. (UL CCS) tested the above equipment in accordance with the requirements set forth in the above standards. All indications of Pass/Fail in this report are opinions expressed by UL CCS based on interpretations and/or observations of test results. Measurement Uncertainties were not taken into account and are published for informational purposes only. The test results show that the equipment tested is capable of demonstrating compliance with the requirements as documented in this report.

**Note:** The results documented in this report apply only to the tested sample, under the conditions and modes of operation as described herein. This document may not be altered or revised in any way unless done so by UL CCS and all revisions are duly noted in the revisions section. Any alteration of this document not carried out by UL CCS will constitute fraud and shall nullify the document. This report must not be used by the client to claim product certification, approval, or endorsement by NVLAP, NIST, any agency of the Federal Government, or any agency of any government.

Approved & Released For UL CCS By:



FRANK IBRAHIM  
EMC SUPERVISOR  
UL CCS

Tested By:

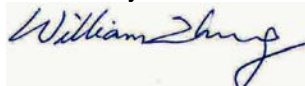

WILLIAM ZHUANG  
EMC ENGINEER  
UL CCS

## 2. TEST METHODOLOGY

The tests documented in this report were performed in accordance with ANSI C63.10-2009, FCC CFR 47 Part 2, FCC CFR 47 Part 15, RSS-GEN Issue 3, and RSS-210 Issue 8.

## 3. FACILITIES AND ACCREDITATION

The test sites and measurement facilities used to collect data are located at 47173 Benicia Street, Fremont, California, USA and at 1285 Walt Whitman Rd, Melville, NY 11747.

UL CCS is accredited by NVLAP, Laboratory Code 200065-0. The full scope of accreditation can be viewed at <http://www.ccsemc.com>.

UL Melville is accredited by NVLAP, Laboratory Code 100255-0.

Harmonics for mid and high channels were performed at UL Melville location, all other test items were performed at UL Fremont location as covered in this report.

## 4. CALIBRATION AND UNCERTAINTY

### 4.1. MEASURING INSTRUMENT CALIBRATION

The measuring equipment utilized to perform the tests documented in this report has been calibrated in accordance with the manufacturer's recommendations, and is traceable to recognized national standards.

### 4.2. SAMPLE CALCULATION

Where relevant, the following sample calculation is provided:

$$\begin{aligned} \text{Field Strength (dBuV/m)} &= \text{Measured Voltage (dBuV)} + \text{Antenna Factor (dB/m)} + \\ &\text{Cable Loss (dB)} - \text{Preamp Gain (dB)} \\ 36.5 \text{ dBuV} + 18.7 \text{ dB/m} + 0.6 \text{ dB} - 26.9 \text{ dB} &= 28.9 \text{ dBuV/m} \end{aligned}$$

### 4.3. MEASUREMENT UNCERTAINTY

Where relevant, the following measurement uncertainty levels have been estimated for tests performed on the apparatus:

#### UL Fremont

PARAMETER	UNCERTAINTY
Conducted Disturbance, 0.15 to 30 MHz	3.52 dB
Radiated Disturbance, 30 to 1000 MHz	4.94 dB

Uncertainty figures are valid to a confidence level of 95%.

#### UL Melville

Test	Uncertainty
Conducted Emissions	$\pm 3.3, k=2$
Radiated Emissions, 30-200MHz, Horizontal	$\pm 3.1, k=2$
Radiated Emissions, 30-200MHz, Vertical	$\pm 3.2, k=2$
Radiated Emissions, 200-1000MHz, Horizontal	$\pm 3.3, k=2$
Radiated Emissions, 200-1000MHz, Vertical	$\pm 4.0, k=2$

## 5. EQUIPMENT UNDER TEST

### 5.1. DESCRIPTION OF EUT

The EUT is a 2.4 GHz transceiver that is manufactured by Anaren, Inc.

### 5.2. MANUFACTURER'S DESCRIPTION OF MODEL DIFFERENCES

A8520E24A91 and A8520E24C91 are Identical, except A8520E24C91 has a U.FL connector, and A8520E24A91 has an integral printed antenna.

### 5.3. MAXIMUM OUTPUT POWER

The selected transmitter maximum output power setting is 'level 4', at which the measured peak conducted output power is as follows:

Frequency Range (MHz)	Mode	Output Power (dBm)	Output Power (mW)
2406 - 2474	QPSK	19.92	98.17

### 5.4. DESCRIPTION OF AVAILABLE ANTENNAS

The radio utilizes PCB antenna with maximum peak gains of 2dBi.

### 5.5. SOFTWARE AND FIRMWARE

The EUT Firmware software installed during testing was v 1.0.3

The test utility software used during testing was 8520 Engineering Software, V1.0.0.99.

### 5.6. WORST-CASE CONFIGURATION AND MODE

EUT is a portable device, therefore, an investigation for worst-case orientation was conducted and it was found the Y orientation is worst-case; final testing was performed with the EUT in Y orientation.

Radiated emissions and power line conducted emissions were performed with the EUT set to transmit at the channel with highest output power as worst-case scenario.

The EUT has a single modulation, which is QPSK.

## 5.7. DESCRIPTION OF TEST SETUP

### SUPPORT EQUIPMENT

#### CONDUCTED TEST

PERIPHERAL SUPPORT EQUIPMENT LIST				
Description	Manufacturer	Model	Serial Number	FCC ID
Laptop	Dell	M4500	5Z2K2M1	DoC
AC Adapter	Dell	DA130PE1-00	CN-07U012-48661-086-00EF-A04	DoC
USB/SPI Converter	Total Phase	I <sup>2</sup> C/SPI	2237-391864	DoC
System JIG	Texas Instruments	TAS57XXEVM	1018002327	DoC

#### RADIATED TEST

PERIPHERAL SUPPORT EQUIPMENT LIST				
Description	Manufacturer	Model	Serial Number	FCC ID
Laptop	IBM	T43	L3-BB983	DoC
AC Adapter	IBM	02K6810	11S02K6810Z123B7514164	DoC
USB/SPI Converter	Total Phase	I <sup>2</sup> C/SPI	2237-392328	DoC
System JIG	Texas Instruments	TAS57XXEVM	1018002406	DoC

#### I/O CABLES

I/O CABLE LIST						
Cable No.	Port	# of Identical Ports	Connector Type	Cable Type	Cable Length	Remarks
1	AC	1	US 115V	Un-shielded	1.0m	N/A
2	DC	1	DC	Un-shielded	2.0m	Ferrite at one End
3	USB	1	USB	Un-shielded	2.0m	N/A
4	USB	1	USB	Un-shielded	1.5m	N/A
5	Data	1	10 Pin	Un-shielded	0.2m	N/A

#### TEST SETUP

The EUT is connected to a host laptop computer via system test board during the tests. Test software exercised the radio card.



**SETUP DIAGRAM FOR TESTS**

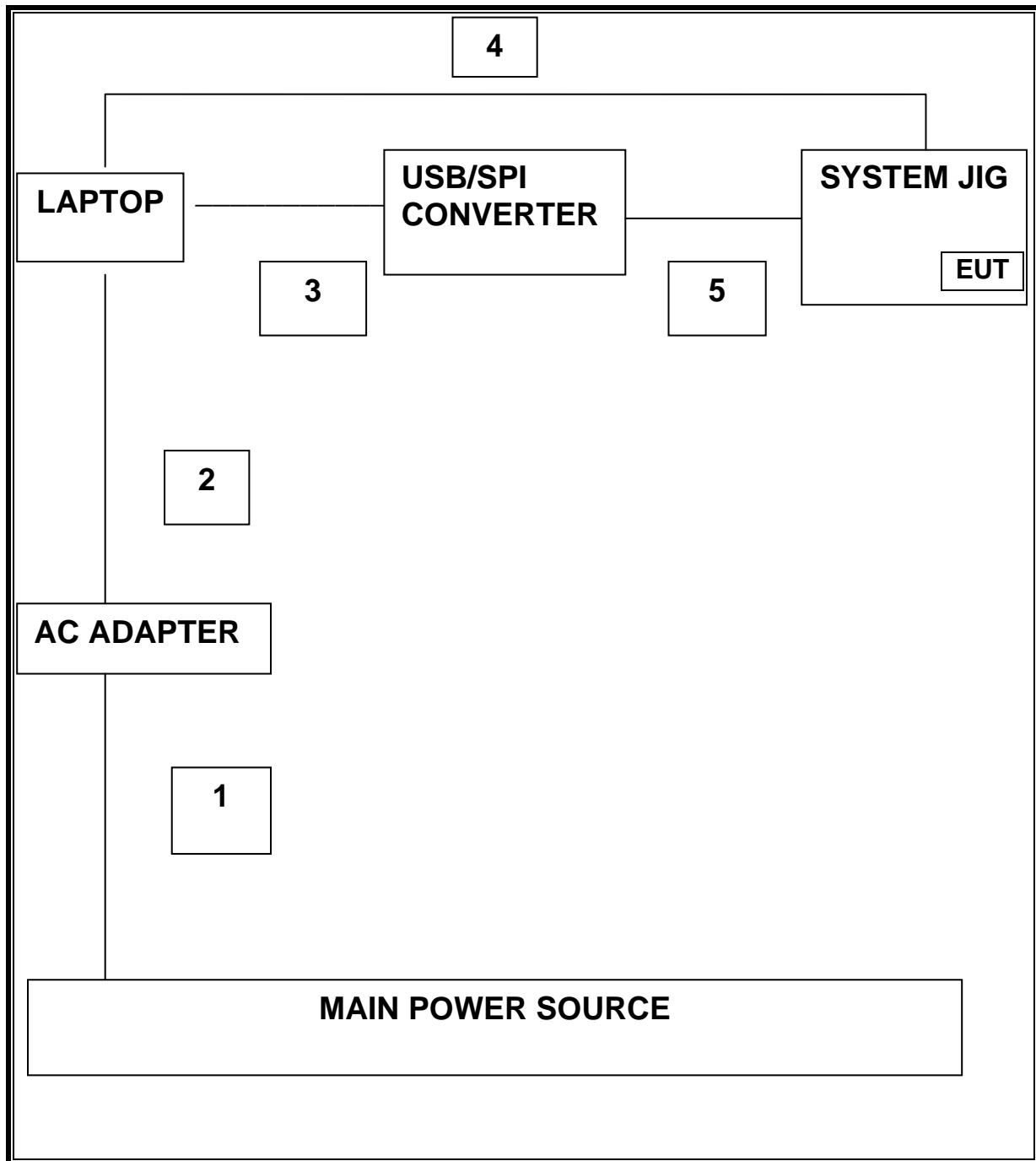

## 6. TEST AND MEASUREMENT EQUIPMENT

The following test and measurement equipment was utilized for the tests documented in this report:

### UL FREMONT

TEST EQUIPMENT LIST				
Description	Manufacturer	Model	Asset	Cal Due
Antenna, Bilog, 2 GHz	Sunol Sciences	JB1	C01011	07/12/12
Antenna, Horn, 18 GHz	EMCO	3115	C00945	06/29/12
Preamplifier, 1300 MHz	Agilent / HP	8447D	C00885	01/06/12
Preamplifier, 26.5 GHz	Agilent / HP	8449B	C01052	07/14/12
LISN, 10 kHz ~ 30 MHz	Solar	8012-50-R-24-BNC	N02481	11/10/12
Spectrum Analyzer, 44 GHz	Agilent / HP	E4446A	C01012	09/03/12
Spectrum Analyzer, 26.5 GHz	Agilent / HP	E4440A	C01179	08/18/12
EMI Test Receiver, 30 MHz	R & S	ESHS 20	N02396	05/06/12
Reject Filter, 2.4-2.5 GHz	Micro-Tronics	BRC13192	N02683	CNR
Peak Power Meter	Boonton	4541	C01186	03/01/12
Peak Power Sensor	Boonton	57318	C01202	02/23/12
Antenna, Horn, 26 GHz	ARA	MWH-1826/B	C00589	07/28/12

### UL MELVILLE

Test Equipment Used					
Description	Manufacturer	Model	Identifier	Cal Date	Cal Due Date
Above 1GHz (Band Optimized System)					
Spectrum Analyzer	Agilent	E4446A	72823	2011-07-26	2012-07-26
Horn Antenna (1-2 GHz)	ETS	3161-01	51442	2008-03-28	See * below
Horn Antenna (2-4 GHz)	ETS	3161-02	48107	2007-09-27	See * below
Horn Antenna (4-8 GHz)	ETS	3161-03	48106	2007-09-27	See * below
Horn Antenna (8-12 GHz)	ETS	3160-07	8933	2008-11-24	See * below
Horn Antenna (12-18 GHz)	ETS	3160-08	8932	2007-09-27	See * below
Horn Antenna (18-26.5 GHz)	ETS	3160-09	8947	2007-09-26	See * below
Signal Path Controller	HP	11713A	50250	N/A	N/A
Gain Controller	HP	11713A	50251	N/A	N/A
RF Switch / Preamp Fixture	UL	BOMS1	50249	N/A	N/A
System Controller	UL	BOMS2	50252	N/A	N/A
Measurement Software	UL	Version 9.3	44740	N/A	N/A
Temp/Humidity/Pressure Meter	Cole Parmer	99760-00	4268	2010-12-07	2012-12-07
<p>* - Note: As allowed by the calibration standard ANSI C63.4 Section 4.4.2, standard gain horns need only a one-time calibration. Only if physical damage occurs will the horn antenna require re-calibration.</p> <p>* Gain standard horn antennas (sometimes called standard gain horn antennas) need not be calibrated beyond that which is provided by the manufacturer unless they are damaged or deterioration is suspected, or they are used at a distance closer than <math>2D^2/\lambda</math>. Gain standard horn antennas have gains that are fixed by their dimensions and dimensional tolerances.</p>					

## 7. ANTENNA PORT TEST RESULTS

### 7.1.1. 6 dB BANDWIDTH

#### LIMITS

FCC §15.247 (a) (2)

IC RSS-210 A8.2 (a)

The minimum 6 dB bandwidth shall be at least 500 kHz.

#### TEST PROCEDURE

The transmitter output is connected to a spectrum analyzer. The RBW is set to 100 kHz and the VBW is set to 300 kHz. The sweep time is coupled.

#### RESULTS

Channel	Frequency (MHz)	6 dB Bandwidth (KHz)	Minimum Limit (kHz)
Low	2406.0	2250.0	500.0
Middle	2442.0	2300.0	500.0
High	2474.0	2200.0	500.0

**6 dB BANDWIDTH**

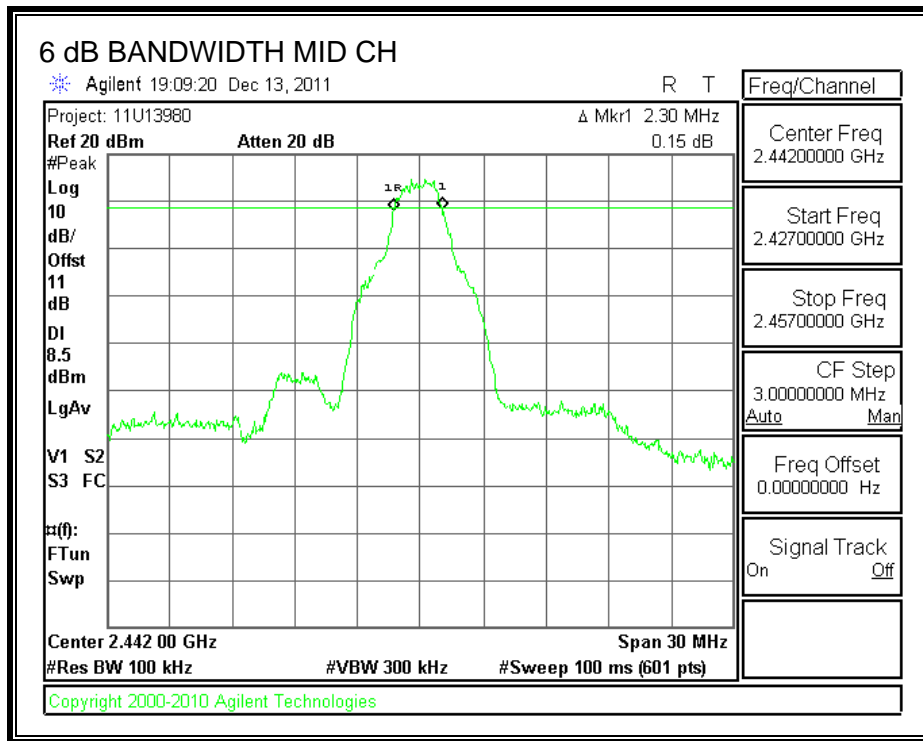
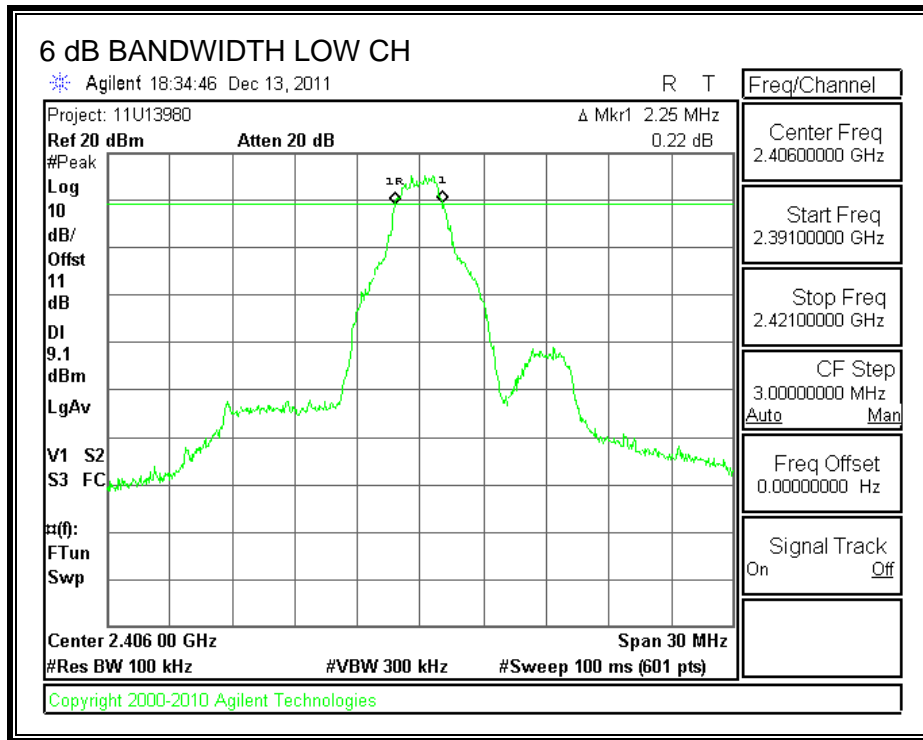

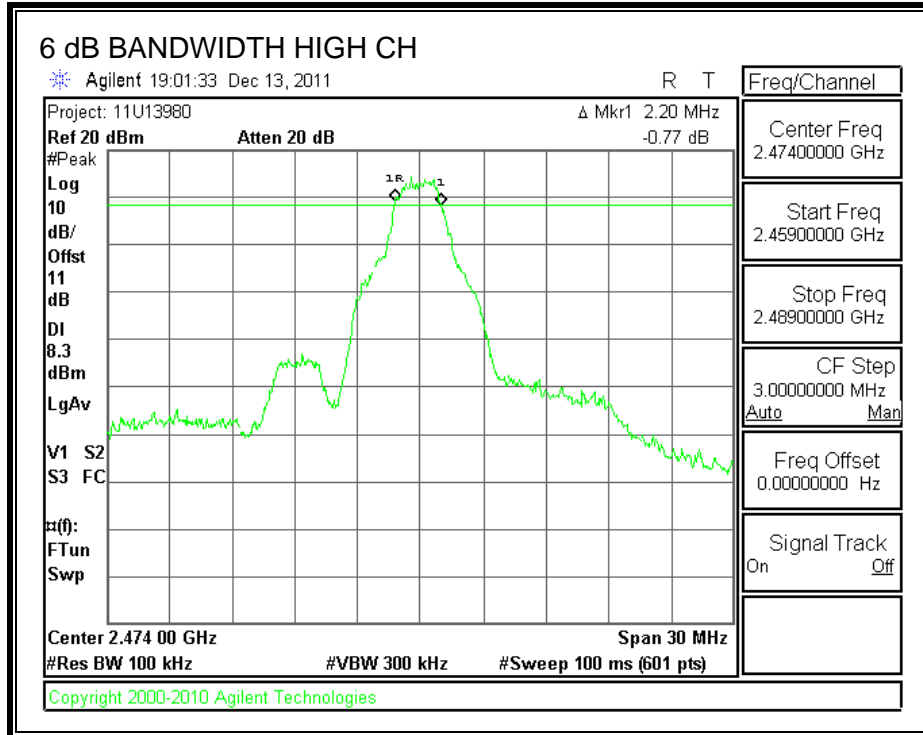

## 7.1.2. 99% BANDWIDTH

### LIMITS

None; for reporting purposes only.

### TEST PROCEDURE

The transmitter output is connected to the spectrum analyzer. The RBW is set to 1% to 3% of the 99 % bandwidth. The VBW is set to 3 times the RBW. The sweep time is coupled. The spectrum analyzer internal 99% bandwidth function is utilized.

### RESULTS

Channel	Frequency (MHz)	99% Bandwidth (KHz)
Low	2406.0	4077.8
Middle	2442.0	3365.1
High	2474.0	3452.5

**99% BANDWIDTH**

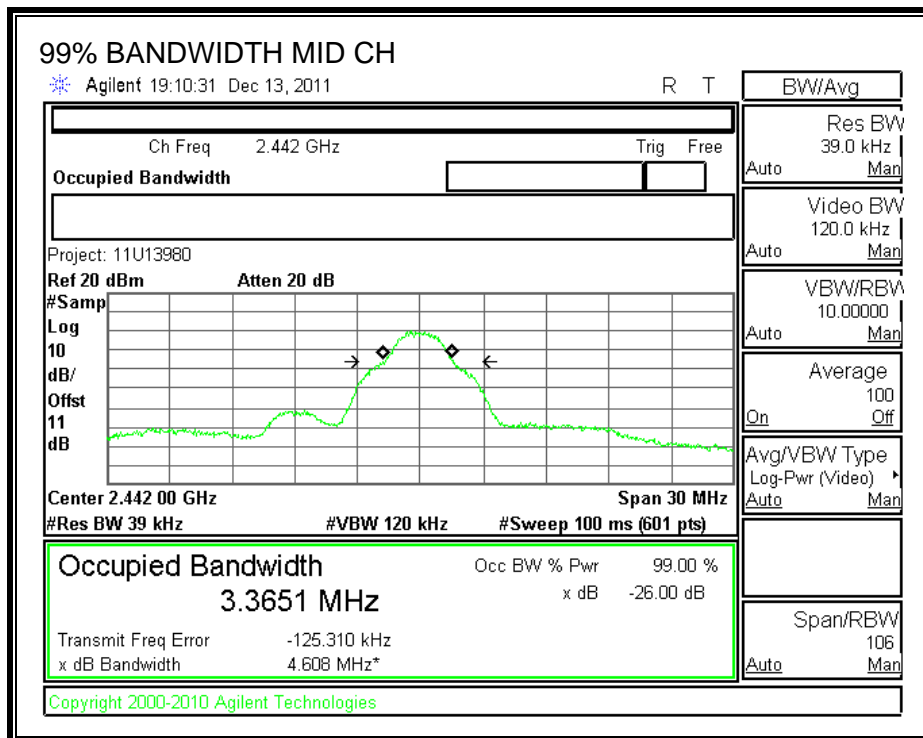
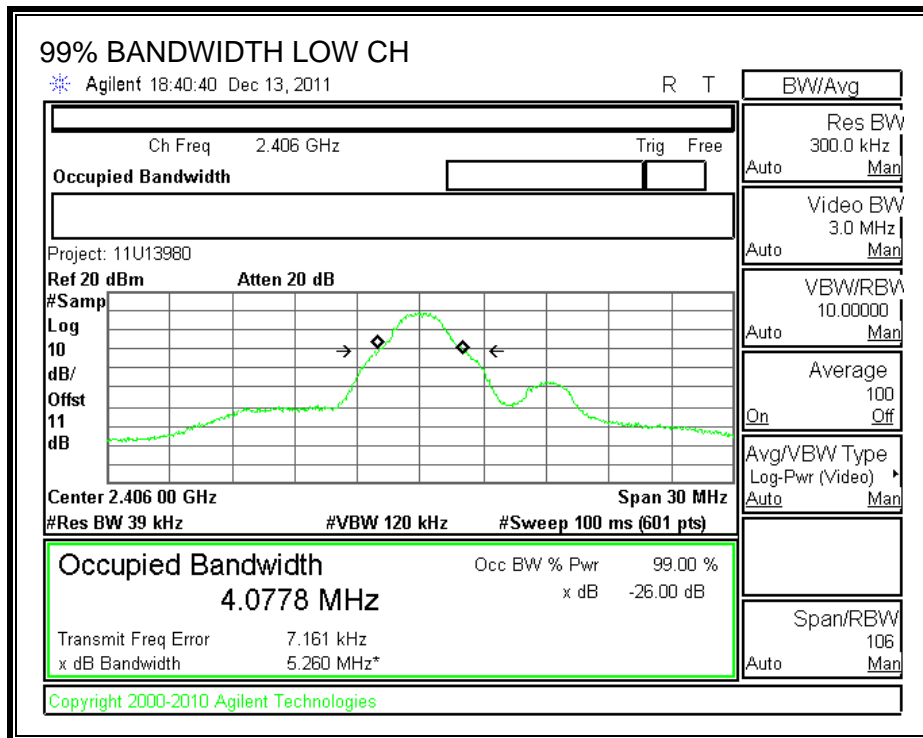

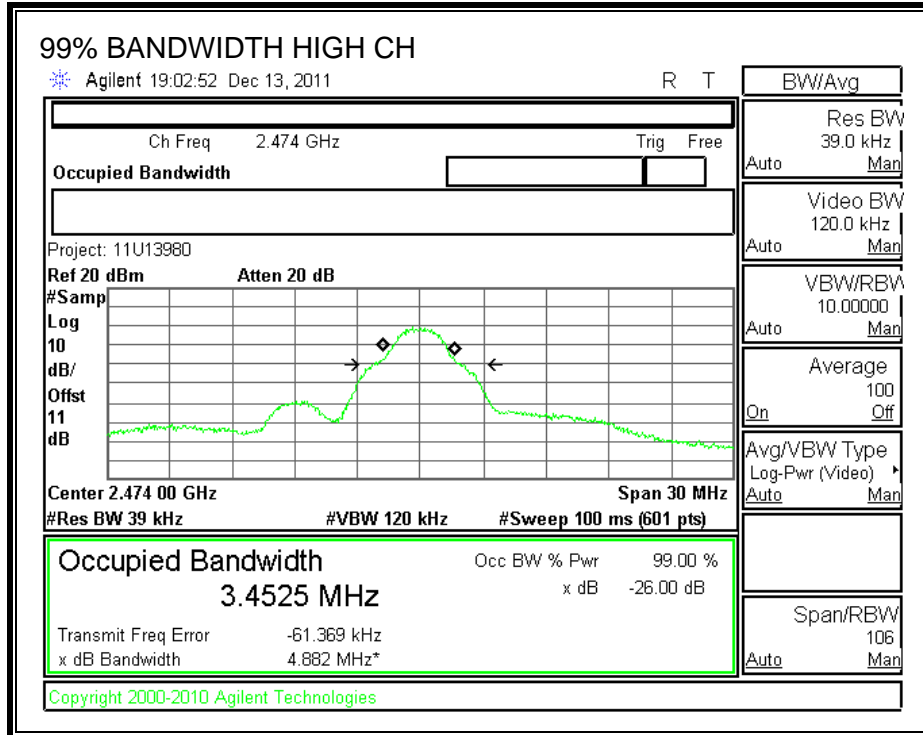



### 7.1.3. OUTPUT POWER

#### LIMITS

FCC §15.247 (b)

IC RSS-210 A8.4

The maximum antenna gain is less than or equal to 6 dBi, therefore the limit is 30 dBm.

#### TEST PROCEDURE

Peak power is measured by the power meter.

#### RESULTS

Channel	Frequency (MHz)	Output Power (dBm)	Limit (dBm)	Margin (dB)
Low	2406.0	19.92	30	-10.08
Middle	2442.0	19.35	30	-10.65
High	2474.0	18.66	30	-11.34

## 7.1.4. AVERAGE POWER

### LIMITS

None; for reporting purposes only.

### TEST PROCEDURE

The transmitter output is connected to a power meter.

### RESULTS

The cable assembly insertion loss of 11 dB was entered as an offset in the power meter to allow for direct reading of power.

Channel	Frequency (MHz)	Power (dBm)
Low	2406.0	17.71
Middle	2442.0	17.24
High	2474.0	16.69

### 7.1.5. POWER SPECTRAL DENSITY

#### LIMITS

FCC §15.247 (e)

IC RSS-210 A8.2 (b)

The power spectral density conducted from the transmitter to the antenna shall not be greater than 8 dBm in any 3 kHz band during any time interval of continuous transmission.

#### TEST PROCEDURE

Output power was measured based on the use of a peak measurement, therefore the power spectral density was measured using PSD Option 1 in accordance with FCC document "Measurement of Digital Transmission Systems Operating under Section 15.247", March 23, 2005.

#### RESULTS

Channel	Frequency (MHz)	PPSD (dBm)	Limit (dBm)	Margin (dB)
Low	2406.0	1.17	8	-6.83
Middle	2442.0	0.80	8	-7.20
High	2474.0	0.62	8	-7.38

**POWER SPECTRAL DENSITY**

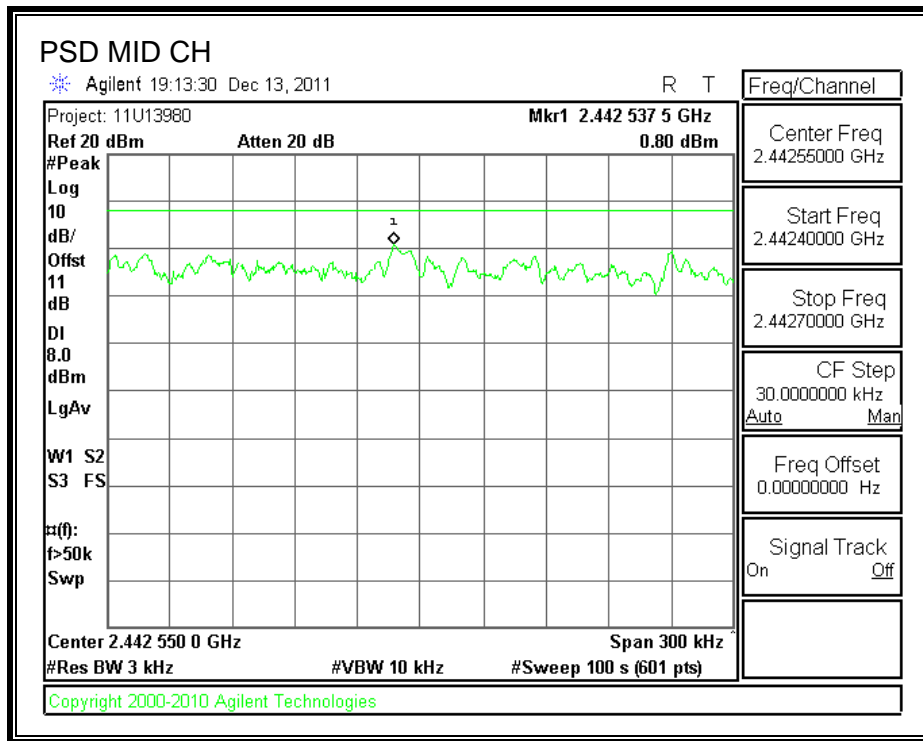
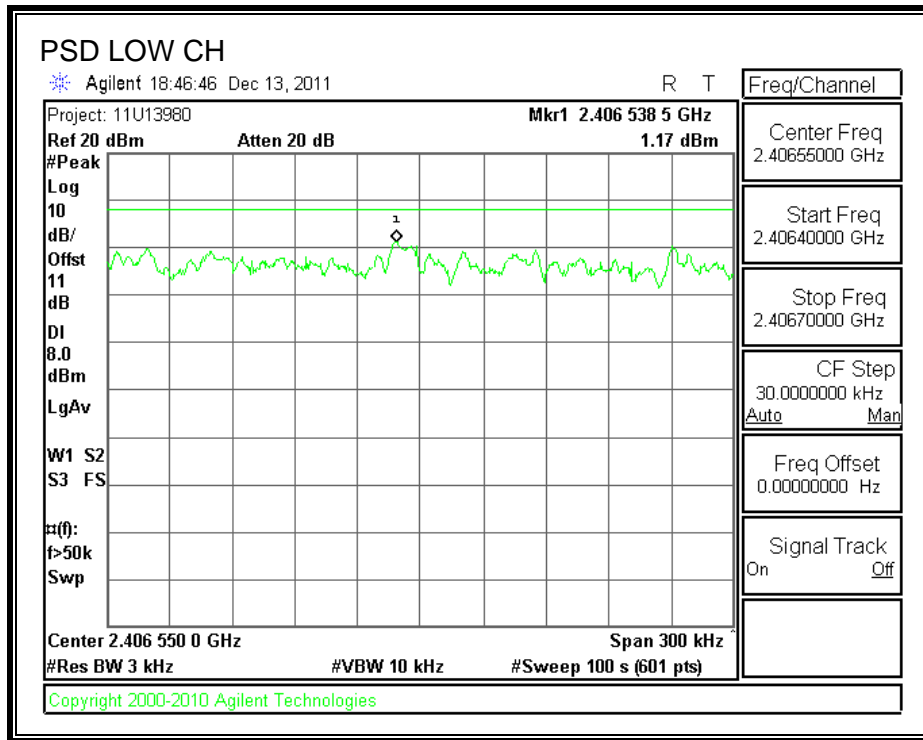

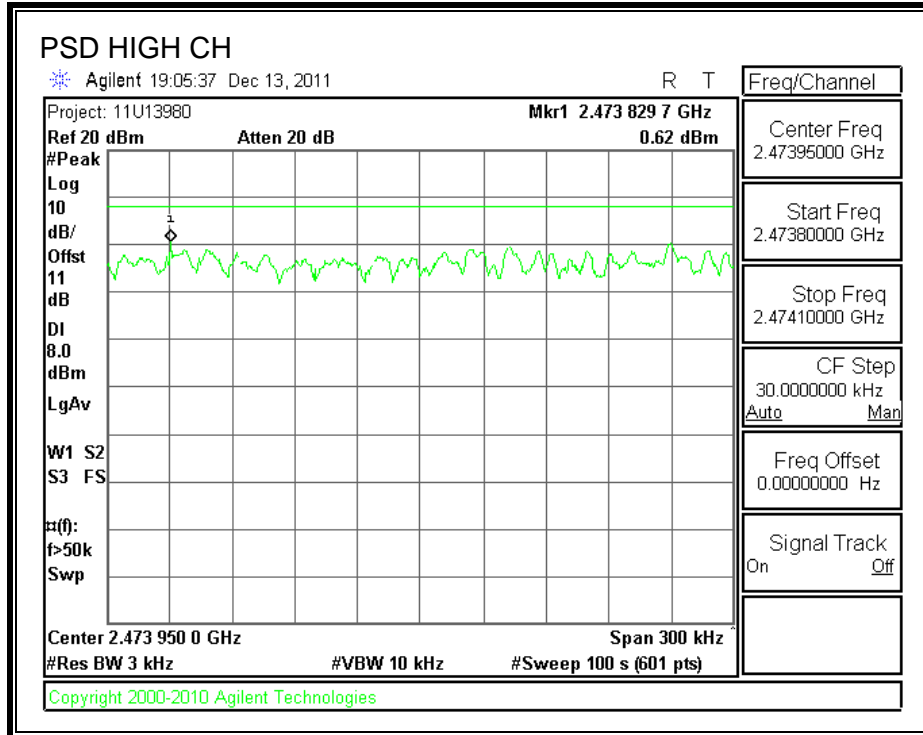

## **7.1.6. CONDUCTED SPURIOUS EMISSIONS**

### **LIMITS**

FCC §15.247 (d)

IC RSS-210 A8.5

Output power was measured based on the use of a peak measurement, therefore the required attenuation is 20 dB.

### **TEST PROCEDURE**

The transmitter output is connected to a spectrum analyzer. The resolution bandwidth is set to 100 kHz. The video bandwidth is set to 300 kHz.

The spectrum from 30 MHz to 26 GHz is investigated with the transmitter set to the lowest, middle, and highest channels.

**RESULTS**

**SPURIOUS EMISSIONS, LOW CHANNEL**

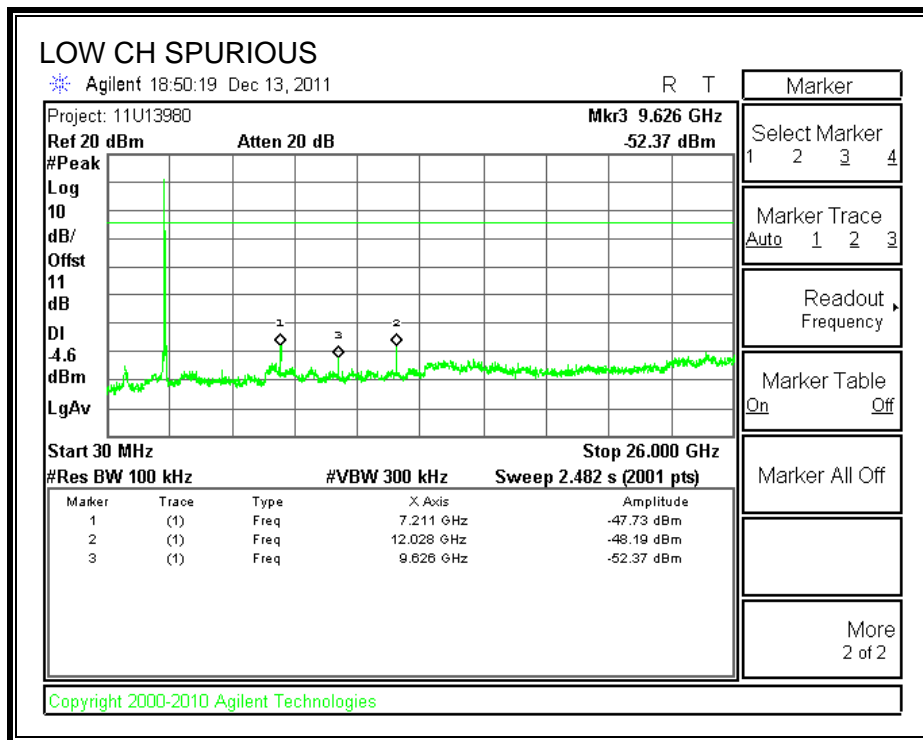
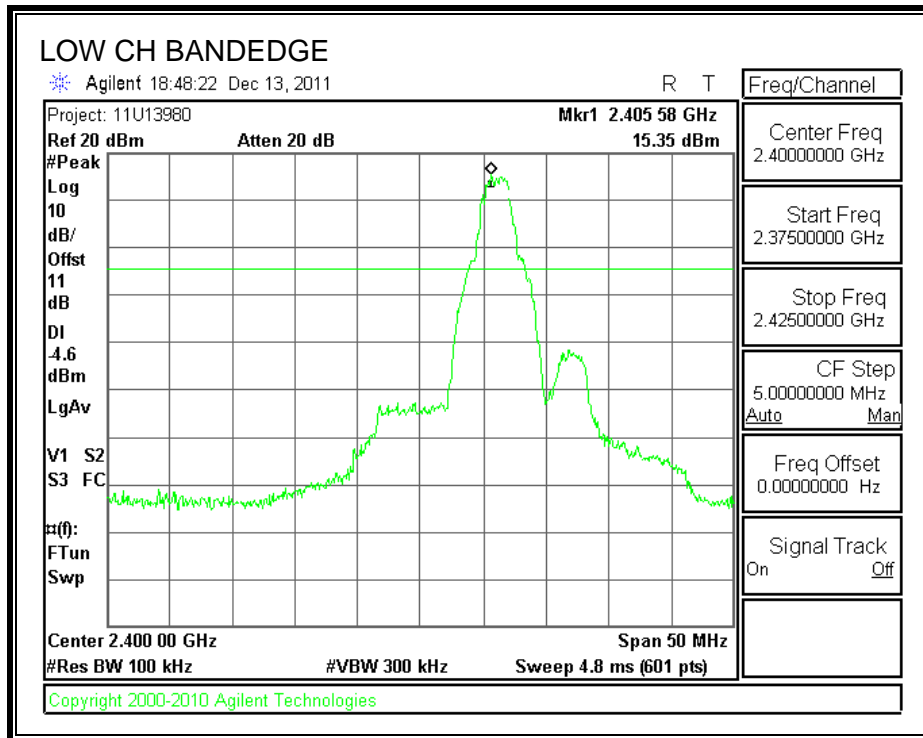

**SPURIOUS EMISSIONS, MID CHANNEL**

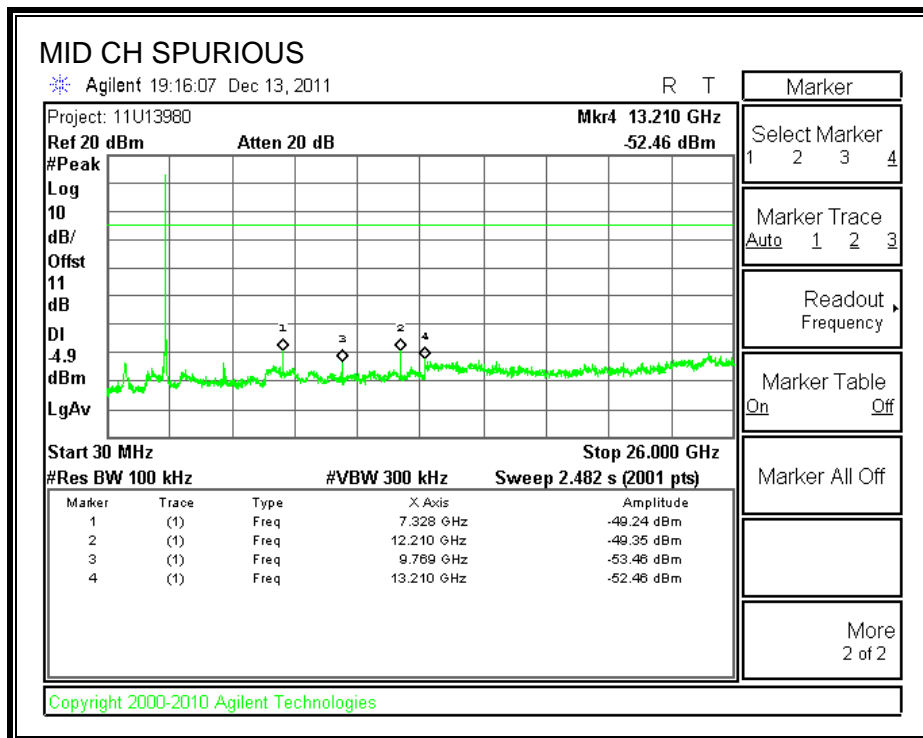
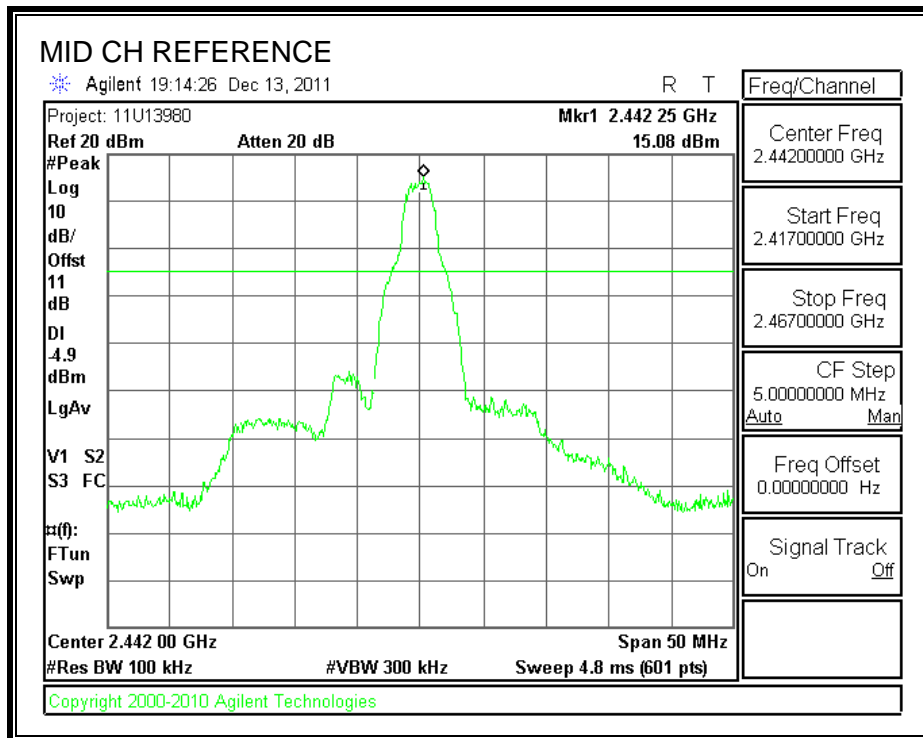



**SPURIOUS EMISSIONS, HIGH CHANNEL**

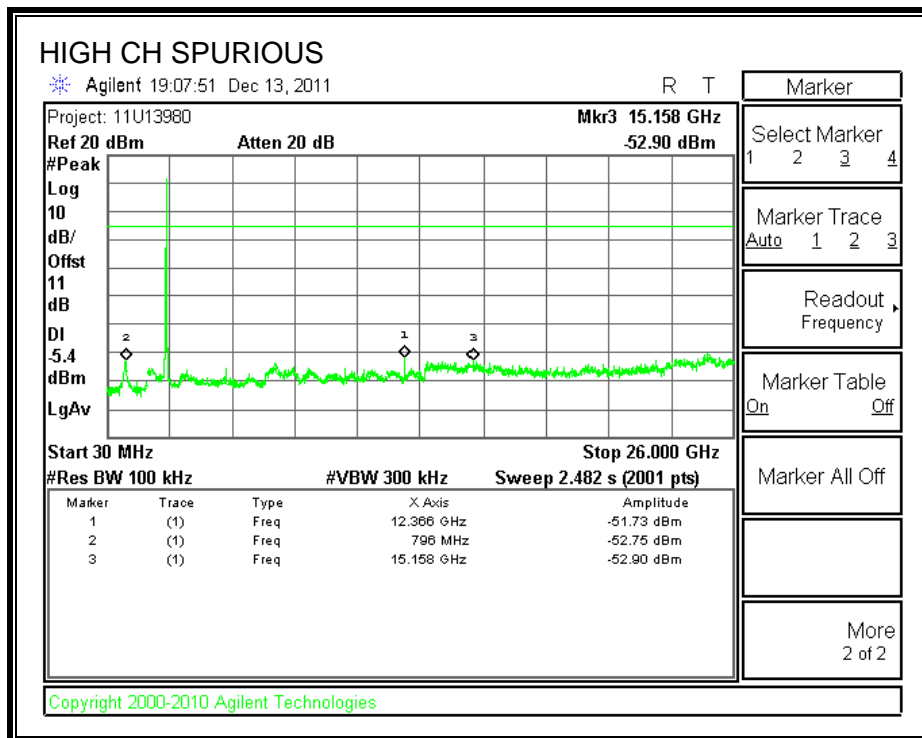
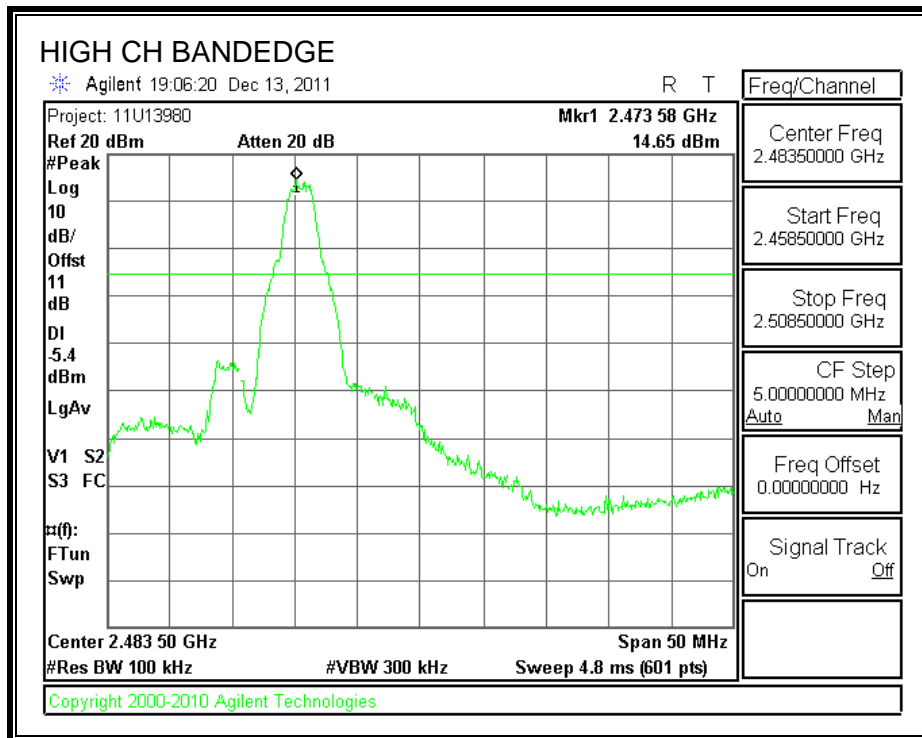

## 8. RADIATED TEST RESULTS

### 8.1. LIMITS AND PROCEDURE

#### LIMITS

FCC §15.205 and §15.209

IC RSS-210 Clause 2.6 (Transmitter)

IC RSS-GEN Clause 6 (Receiver)

Frequency Range (MHz)	Field Strength Limit (uV/m) at 3 m	Field Strength Limit (dBuV/m) at 3 m
30 - 88	100	40
88 - 216	150	43.5
216 - 960	200	46
Above 960	500	54

#### TEST PROCEDURE

The EUT is placed on a non-conducting table 80 cm above the ground plane. The antenna to EUT distance is 3 meters. The EUT is configured in accordance with ANSI C63.4. The EUT is set to transmit in a continuous mode.

For measurements below 1 GHz the resolution bandwidth is set to 100 kHz for peak detection measurements or 120 kHz for quasi-peak detection measurements. Peak detection is used unless otherwise noted as quasi-peak.

For measurements above 1 GHz the resolution bandwidth is set to 1 MHz, then the video bandwidth is set to 1 MHz for peak measurements and 10 Hz for average measurements.

The spectrum from 30 MHz to 26 GHz is investigated with the transmitter set to the lowest, middle, and highest channels in the 2.4 GHz band.

The frequency range of interest is monitored at a fixed antenna height and EUT azimuth. The EUT is rotated through 360 degrees to maximize emissions received. The antenna is scanned from 1 to 4 meters above the ground plane to further maximize the emission. Measurements are made with the antenna polarized in both the vertical and the horizontal positions.

## 8.2. TRANSMITTER ABOVE 1 GHz

### RESTRICTED BANDEDGE (LOW CHANNEL, HORIZONTAL)

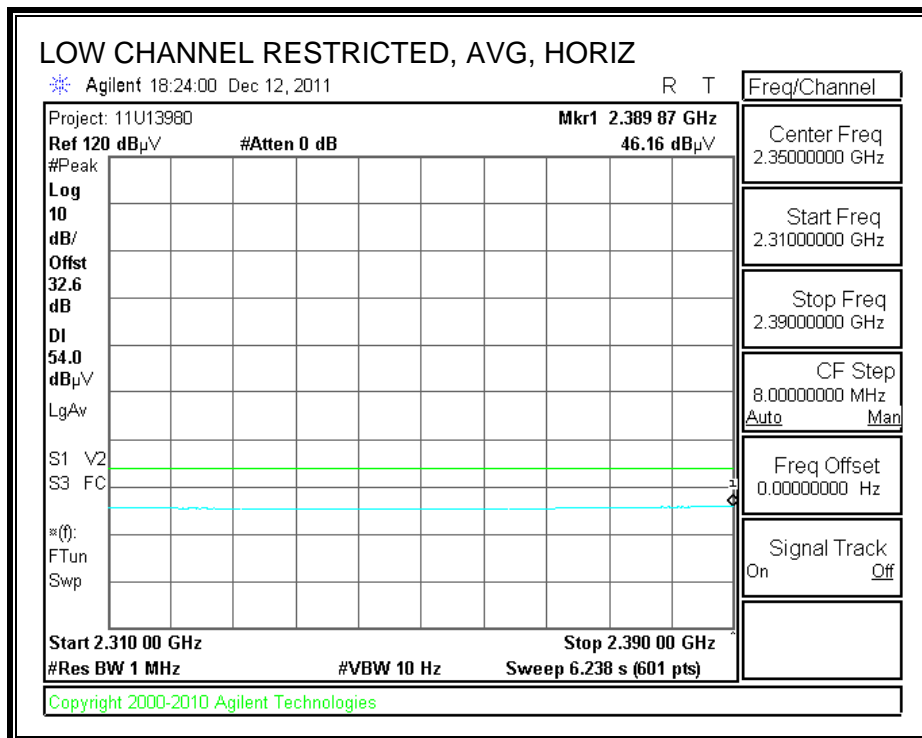
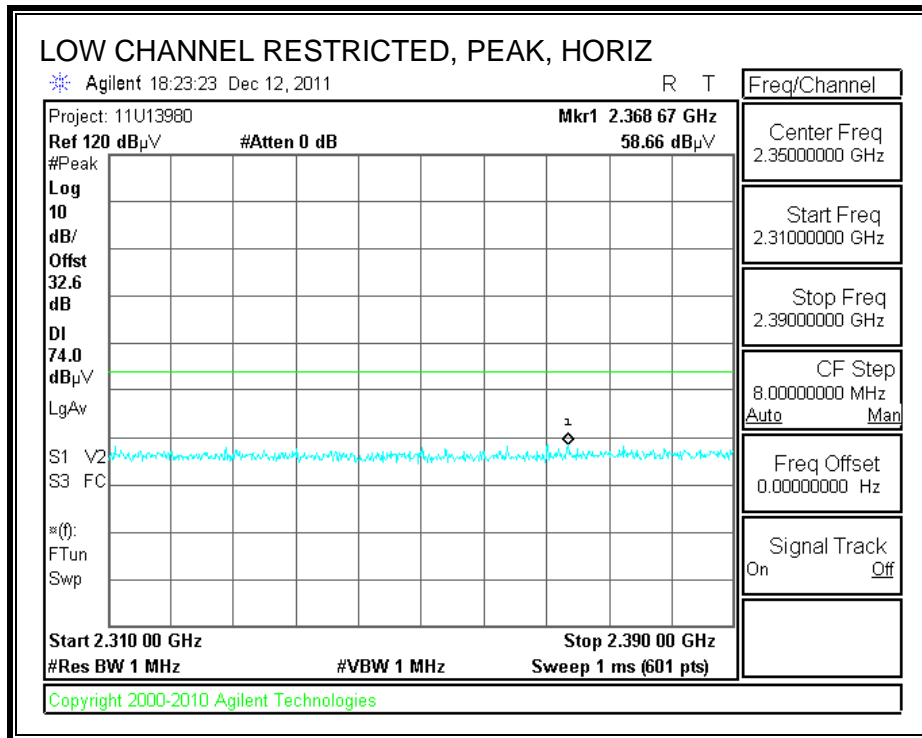

**RESTRICTED BANDEDGE (LOW CHANNEL, VERTICAL)**

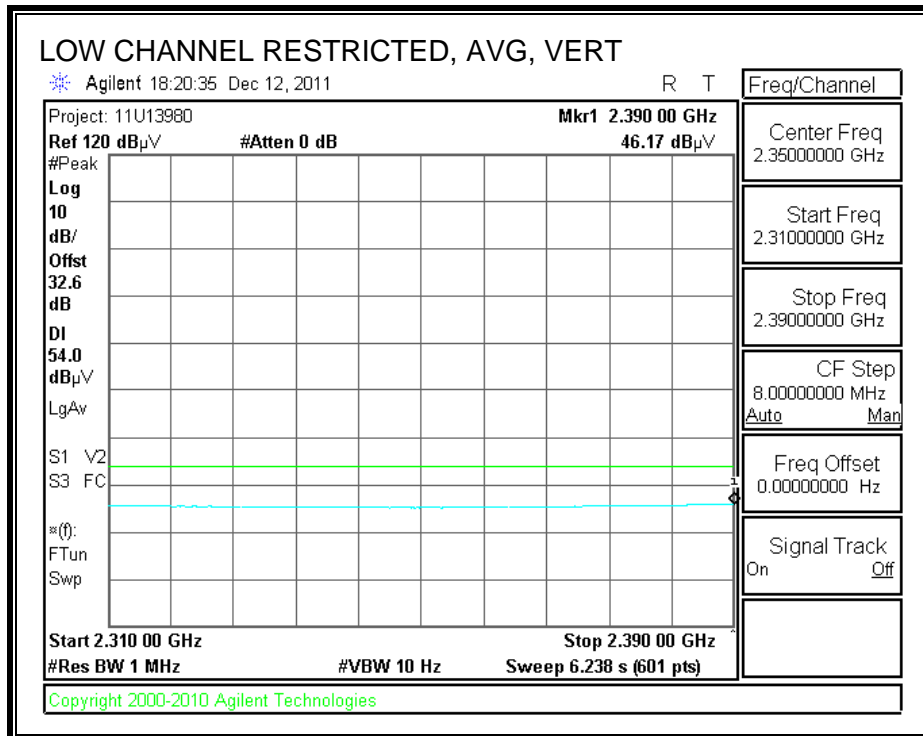
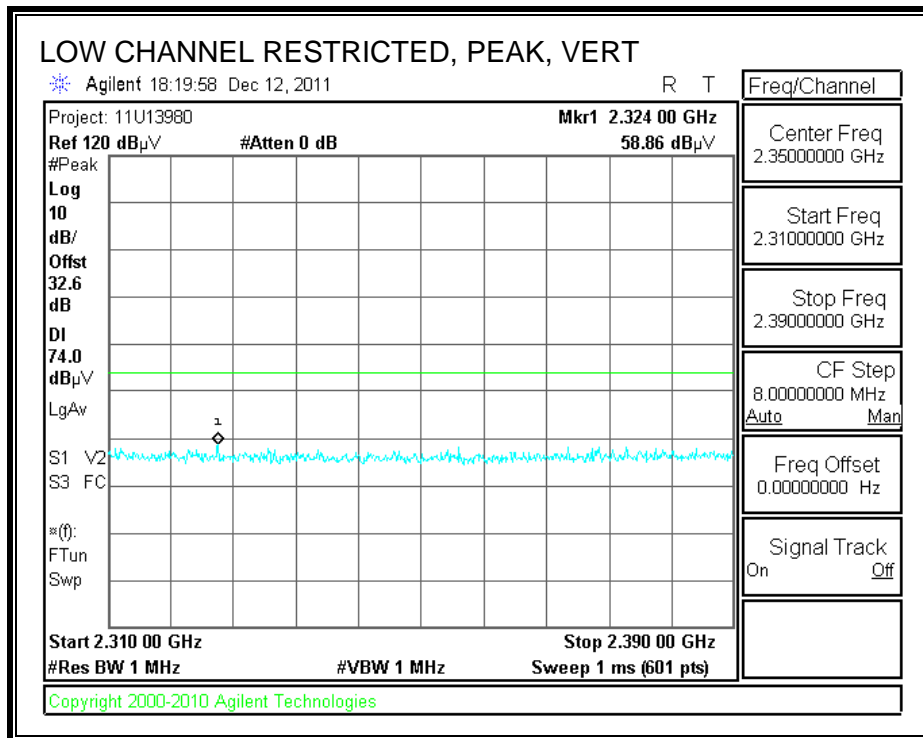

**RESTRICTED BANDEDGE (HIGH CHANNEL, HORIZONTAL)**

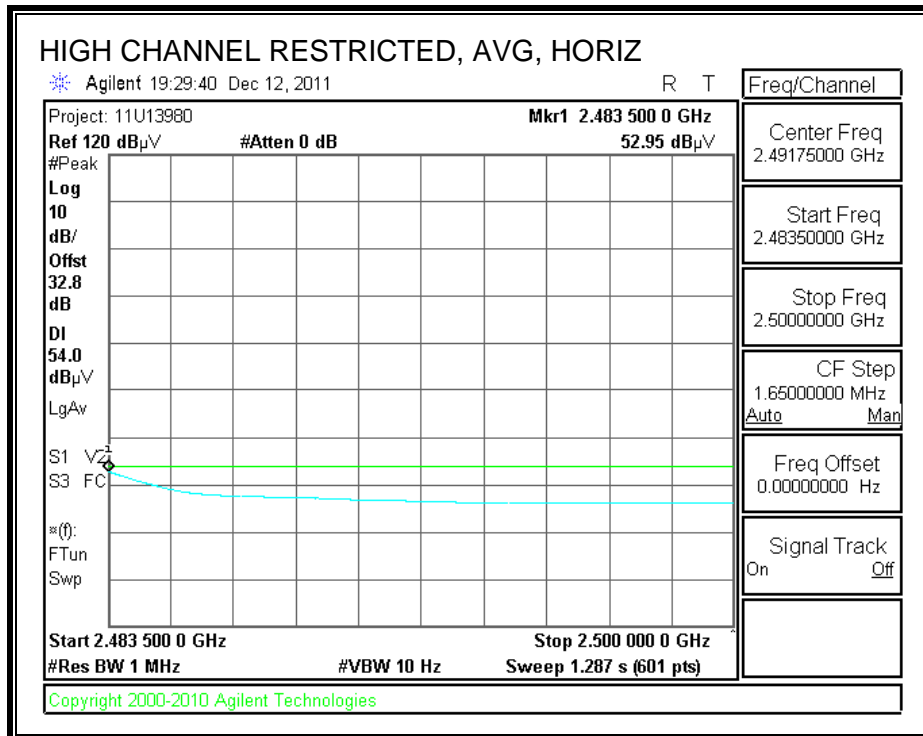
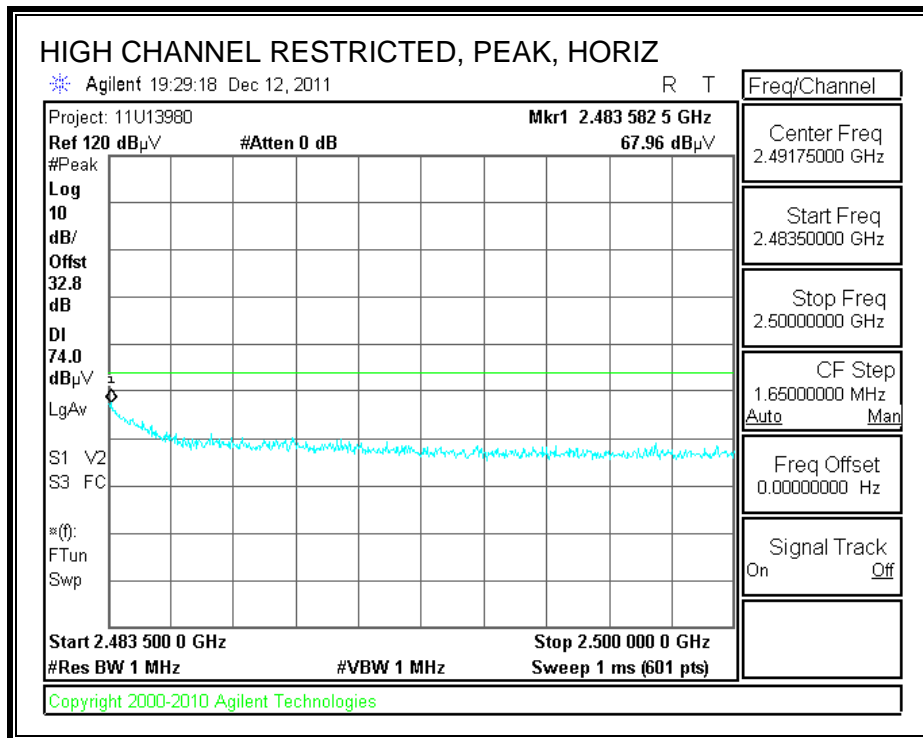

**RESTRICTED BANDEDGE (HIGH CHANNEL, VERTICAL)**

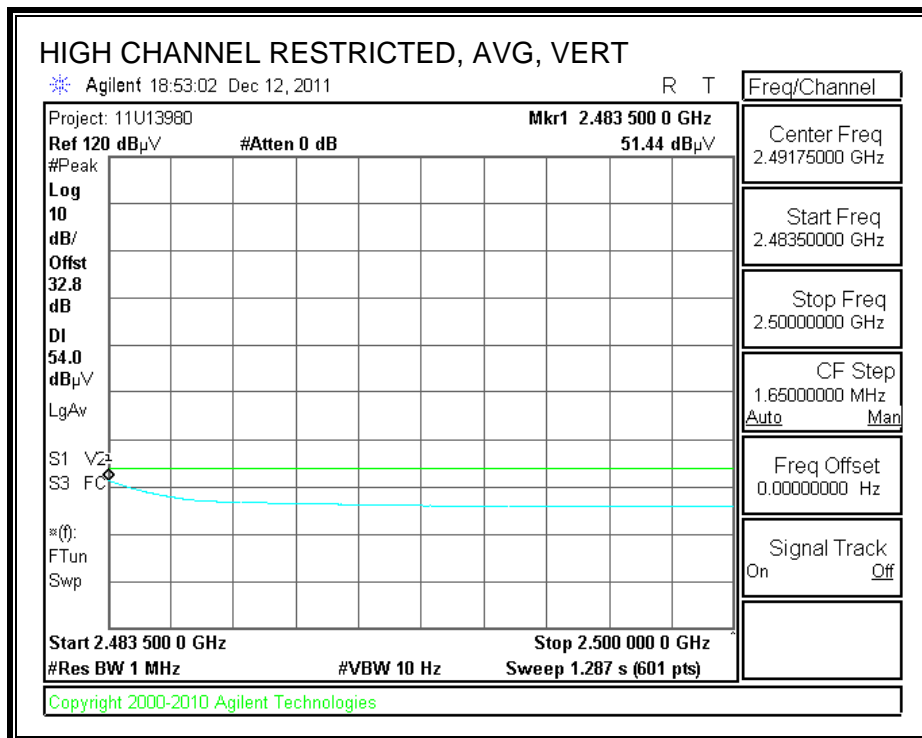
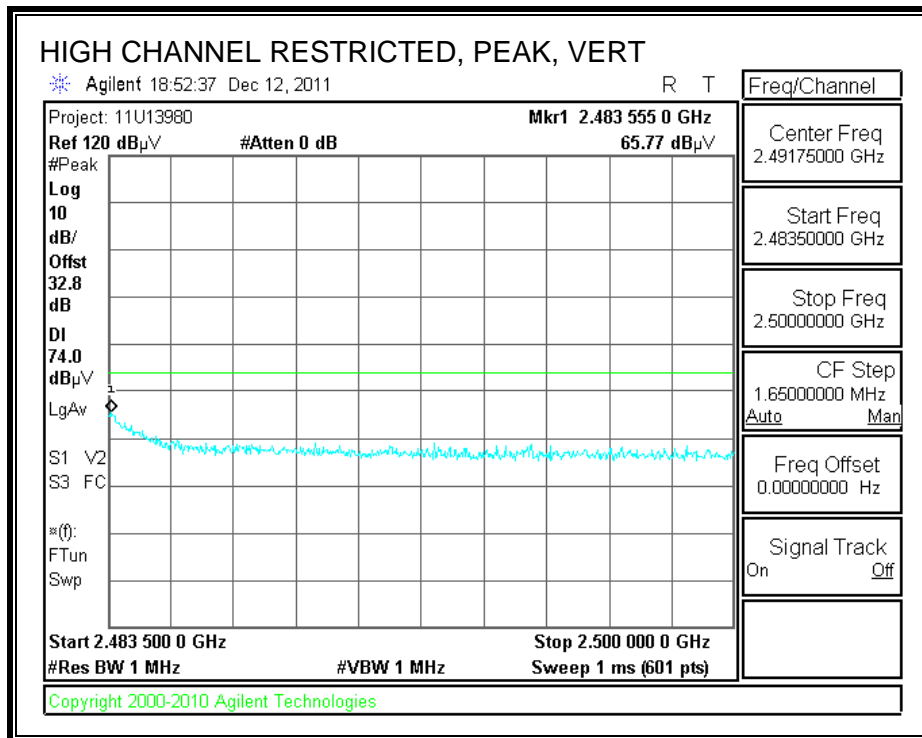

**HARMONICS AND SPURIOUS EMISSIONS**

**Low Ch.**

High Frequency Measurement  
 Compliance Certification Services, Fremont 5m Chamber

Test Engr: William Zhuang  
 Date: 12/12/11  
 Project #: 11U13980  
 Company: Anaren  
 Test Target: FCC B  
 Mode Oper: QPSK, Pwr set 4

f Measurement Frequency Amp Preamp Gain Average Field Strength Limit  
 Dist Distance to Antenna D Corr Distance Correct to 3 meters Peak Field Strength Limit  
 Read Analyzer Reading Avg Average Field Strength @ 3 m Margin vs. Average Limit  
 AF Antenna Factor Peak Calculated Peak Field Strength Margin vs. Peak Limit  
 CL Cable Loss HPF High Pass Filter

f GHz	Dist (m)	Read dBuV	AF dB/m	CL dB	Amp dB	D Corr dB	Filtr dB	Corr. dBuV/m	Limit dBuV/m	Margin dB	Ant. Pol V/H	Det. P/A/QP	Ant.High cm	Table Angle Degree	Notes
Low Ch. 2406 MHz															
4.812	3.0	51.2	33.1	6.8	-34.8	0.0	0.0	56.3	74.0	-17.7	V	P	98.0	160.0	
4.812	3.0	41.5	33.1	6.8	-34.8	0.0	0.0	46.6	54.0	-7.4	V	A	98.0	160.0	
4.812	3.0	53.5	33.1	6.8	-34.8	0.0	0.0	58.5	74.0	-15.5	H	P	98.0	292.0	
4.812	3.0	44.2	33.1	6.8	-34.8	0.0	0.0	49.2	54.0	-4.8	H	A	98.0	292.0	
12.030	3.0	40.8	39.4	11.9	-32.5	0.0	0.0	59.6	74.0	-14.4	H	P	144.0	315.0	
12.030	3.0	27.3	39.4	11.9	-32.5	0.0	0.0	46.1	54.0	-7.9	H	A	144.0	315.0	
12.030	3.0	40.8	39.4	11.9	-32.5	0.0	0.0	59.6	74.0	-14.4	V	P	117.0	307.0	
12.030	3.0	28.2	39.4	11.9	-32.5	0.0	0.0	47.0	54.0	-7.0	V	A	117.0	307.0	

Rev. 4.1.2.7

Note: No other emissions were detected above the system noise floor.

**Middle channel**

Anaren  
 Model: A8520E24A91  
 Xmitter Module - Mid Channel  
 Job#: 11U14706  
 Tested by: MA

Horizontal 4000 - 8000MHz

Test Frequency	Meter Reading	Detector	AF-48106 [dB]	BOMS Factor [dB]	dB[uVolts/meter]	FCC Part 15 Subpart C 15.209	Margin	FCC Part 15 Subpart C Peak	Margin	Azimuth [Degs]	Height [cm]	Polarity
4878.0547	83.04	PK	27.2	-52.52	57.72			74	-16.28	58	232	Horz
4878.0547	65.88	LgAv	27.2	-52.52	40.56	54	-13.44			58	232	Horz
4882.0166	78.54	PK	27.2	-52.53	53.21			74	-20.79	2	218	Horz
4882.0166	77.55	LgAv	27.2	-52.53	52.22	54	-1.78			2	218	Horz
7317.0781	93.91	PK	28	-51.92	69.99			74	-4.01	3	361	Horz
7317.0781	74.39	LgAv	28	-51.92	50.47	54	-3.53			3	361	Horz

Horizontal 8000 - 12000MHz

Test Frequency	Meter Reading	Detector	AF-8933 [dB]	BOMS Factor [dB]	dB[uVolts/meter]	FCC Part 15 Subpart C 15.209	Margin	FCC Part 15 Subpart C Peak	Margin	Azimuth [Degs]	Height [cm]	Polarity
9753.7578	69.46	PK	33.2	-49.12	53.54			74	-20.46	321	379	Horz
9753.7578	54.04	LgAv	33.2	-49.12	38.12	54	-15.88			321	379	Horz

Horizontal 12000 - 18000MHz

Test Frequency	Meter Reading	Detector	AF-8932 [dB]	BOMS Factor [dB]	dB[uVolts/meter]	FCC Part 15 Subpart C 15.209	Margin	FCC Part 15 Subpart C Peak	Margin	Azimuth [Degs]	Height [cm]	Polarity
12189.172	67.56	PK	37.2	-48.21	56.55			74	-17.45	172	377	Horz
12189.172	51.24	LgAv	37.2	-48.21	40.23	54	-13.77			172	377	Horz
14632.452	64.12	PK	37.3	-49.14	52.28			74	-21.72	68	336	Horz
14632.452	47.1	LgAv	37.3	-49.14	35.26	54	-18.74			68	336	Horz

Vertical 4000 - 8000MHz

Test Frequency	Meter Reading	Detector	AF-48106 [dB]	BOMS Factor [dB]	dB[uVolts/meter]	FCC Part 15 Subpart C 15.209	Margin	FCC Part 15 Subpart C Peak	Margin	Azimuth [Degs]	Height [cm]	Polarity
4878.015	76.76	PK	27.5	-52.52	51.74			74	-22.26	7	365	Vert
4878.015	59.77	LgAv	27.5	-52.52	34.75	54	-19.25			7	365	Vert
4881.993	71.7	PK	27.5	-52.52	46.68			74	-27.32	74	290	Vert
4881.993	69.4	LgAv	27.5	-52.52	44.38	54	-9.62			74	290	Vert
7317.092	84.88	PK	27.9	-51.92	60.86			74	-13.14	146	118	Vert
7317.092	65.39	LgAv	27.9	-51.92	41.37	54	-12.63			146	118	Vert

Vertical 8000 - 12000MHz

Test Frequency	Meter Reading	Detector	AF-8933 [dB]	BOMS Factor [dB]	dB[uVolts/meter]	FCC Part 15 Subpart C 15.209	Margin	FCC Part 15 Subpart C Peak	Margin	Azimuth [Degs]	Height [cm]	Polarity
9753.6	69.17	PK	33.2	-49.12	53.25			74	-20.75	48	103	Vert
9753.6	54.25	LgAv	33.2	-49.12	38.33	54	-15.67			48	103	Vert

Vertical 12000 - 18000MHz

Test Frequency	Meter Reading	Detector	AF-8932 [dB]	BOMS Factor [dB]	dB[uVolts/meter]	FCC Part 15 Subpart C 15.209	Margin	FCC Part 15 Subpart C Peak	Margin	Azimuth [Degs]	Height [cm]	Polarity
12189.22	72.19	PK	37.3	-48.21	61.28			74	-12.72	114	113	Vert
12189.22	55.99	LgAv	37.3	-48.21	45.08	54	-8.92			114	113	Vert
14632.96	59.68	PK	37.3	-49.14	47.84			74	-26.16	142	367	Vert
14632.96	44.98	LgAv	37.3	-49.14	33.14	54	-20.86			142	367	Vert

PK - Peak detector  
 QP - Quasi-Peak detector  
 LnAv - Linear Average detector  
 LgAv - Log Average detector  
 Av - Average detector  
 CAV - CISPR Average detector  
 RMS - RMS detection  
 CRMS - CISPR RMS detection  
 Text File: FCCPt15 Subpart C Harmonics - Mid Channel.TXT  
 File: BOMS 1GHz - 26GHz General Pt 15 Sub C 15\_209.TST



### High channel

Anaren  
 Model: A8520E24A91  
 Xmitter Module - High Channel  
 Job#: 11U14706  
 Tested by: MA

#### Horizontal 4000 - 8000MHz

Test Frequency	Meter		AF-48106 [dB]	BOMS Factor [dB]	dB[uVolts/meter]	FCC Part 15		FCC Part 15		Azimuth [Degs]	Height [cm]	Polarity
	Reading	Detector				Subpart C	Margin	Subpart C Peak	Margin			
4941.9938	79.04	PK	27.3	-52.53	53.81			74	-20.19	360	280	Horz
4941.9938	77.99	LgAv	27.3	-52.53	52.76	54	-1.24			360	280	Horz
4948.932	77.5	PK	27.3	-52.59	52.21			74	-21.79	20	333	Horz
4948.932	65.47	LgAv	27.3	-52.59	40.18	54	-13.82			20	333	Horz
7418.832	93.24	PK	28.1	-51.22	70.12			74	-3.88	34	351	Horz
7418.832	73.58	LgAv	28.1	-51.22	50.46	54	-3.54			34	351	Horz

#### Horizontal 8000 - 12000MHz

Test Frequency	Meter		AF-8933 [dB]	BOMS Factor [dB]	dB[uVolts/meter]	FCC Part 15		FCC Part 15		Azimuth [Degs]	Height [cm]	Polarity
	Reading	Detector				Subpart C	Margin	Subpart C Peak	Margin			
9895.42	69.73	PK	33	-49.17	53.56			74	-20.44	0	329	Horz
9895.42	54.73	LgAv	33	-49.17	38.56	54	-15.44			0	329	Horz

#### Horizontal 12000 - 18000MHz

Test Frequency	Meter		AF-8932 [dB]	BOMS Factor [dB]	dB[uVolts/meter]	FCC Part 15		FCC Part 15		Azimuth [Degs]	Height [cm]	Polarity
	Reading	Detector				Subpart C	Margin	Subpart C Peak	Margin			
12367.59	70.28	PK	37.2	-48.87	58.61			74	-15.39	307	138	Horz
12367.59	53.43	LgAv	37.2	-48.87	41.76	54	-12.24			307	138	Horz
14841.328	61.01	PK	37.3	-49.03	49.28			74	-24.72	313	161	Horz
14841.328	45.12	LgAv	37.3	-49.03	33.39	54	-20.61			313	161	Horz

#### Vertical 4000 - 8000MHz

Test Frequency	Meter		AF-48106 [dB]	BOMS Factor [dB]	dB[uVolts/meter]	FCC Part 15		FCC Part 15		Azimuth [Degs]	Height [cm]	Polarity
	Reading	Detector				Subpart C	Margin	Subpart C Peak	Margin			
4941.9675	74.85	PK	27.5	-52.53	49.82			74	-24.18	199	261	Vert
4941.9675	73.39	LgAv	27.5	-52.53	48.36	54	-5.64			199	261	Vert
4948.804	73.07	PK	27.5	-52.59	47.98			74	-26.02	181	112	Vert
4948.804	60.99	LgAv	27.5	-52.59	35.9	54	-18.1			181	112	Vert
7418.844	88.52	PK	28	-51.22	65.3			74	-8.7	57	203	Vert
7418.844	68.98	LgAv	28	-51.22	45.76	54	-8.24			57	203	Vert

#### Vertical 8000 - 12000MHz

Test Frequency	Meter		AF-8933 [dB]	BOMS Factor [dB]	dB[uVolts/meter]	FCC Part 15		FCC Part 15		Azimuth [Degs]	Height [cm]	Polarity
	Reading	Detector				Subpart C	Margin	Subpart C Peak	Margin			
9895.44	72.3	PK	33	-49.17	56.13			74	-17.87	77	211	Vert
9895.44	57.43	LgAv	33	-49.17	41.26	54	-12.74			77	211	Vert

#### Vertical 12000 - 18000MHz

Test Frequency	Meter		AF-8932 [dB]	BOMS Factor [dB]	dB[uVolts/meter]	FCC Part 15		FCC Part 15		Azimuth [Degs]	Height [cm]	Polarity
	Reading	Detector				Subpart C	Margin	Subpart C Peak	Margin			
12369.25	74.18	PK	37.3	-48.85	62.63			74	-11.37	72	179	Vert
12369.25	58.06	LgAv	37.3	-48.85	46.51	54	-7.49			72	179	Vert

PK - Peak detector  
 QP - Quasi-Peak detector  
 LnAv - Linear Average detector  
 LgAv - Log Average detector  
 Av - Average detector  
 CAV - CISPR Average detector  
 RMS - RMS detection  
 CRMS - CISPR RMS detection  
 Text File: FCCPt15 Subpart C Harmonics - High Channel.TXT  
 File: BOMS 1GHz - 26GHz General Pt 15 Sub C 15\_209.TST

### 8.3. WORST-CASE BELOW 1 GHz

#### SPURIOUS EMISSIONS 30 TO 1000 MHz (WORST-CASE CONFIGURATION)

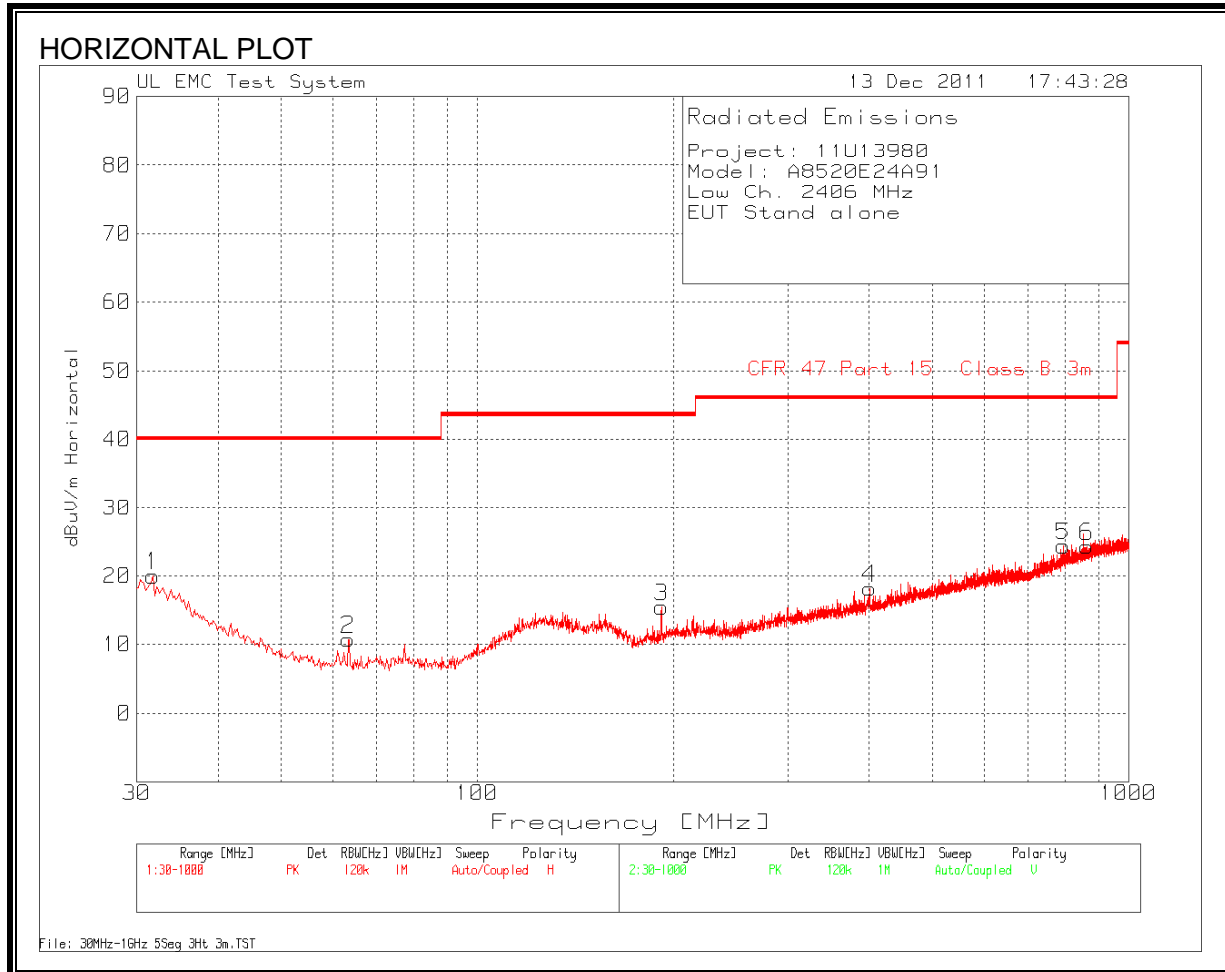

VERTICAL PLOT

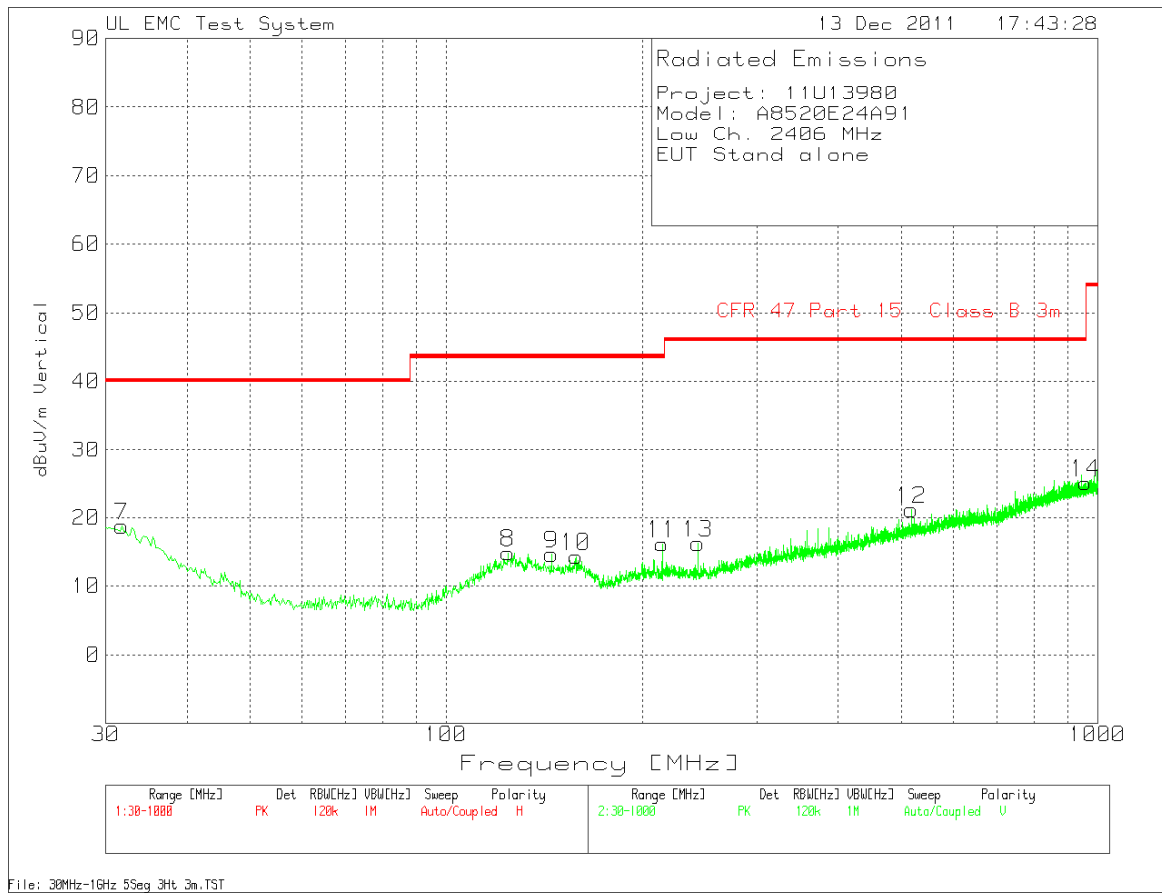

**VERTICAL AND HORIZONTAL DATA**

VERTICAL AND HORIZONTAL DATA									
Project: 11U13980									
Model: A8520E24A91									
Low Ch. 2406 MHz									
EUT Stand alone									
Range: 1 30 - 1000MHz									
Test Frequency	Meter Reading	Detector	25MHz-1GHz Chambr 3m Amplified [dB]	3m Bilog T185 below 1GHz.TXT [dB]	dBuV/m	CFR 47 Part 15 Class B 3m	Margin	Height [cm]	Polarity
31.7446	28.4	PK	-27.5	19.1	20	40	-20	99	Horz
63.4383	29.94	PK	-27.2	8	10.74	40	-29.26	251	Horz
191.8605	29.96	PK	-25.9	11.4	15.46	43.5	-28.04	99	Horz
400.8253	28.78	PK	-25.6	15	18.18	46	-27.82	251	Horz
793.749	28.24	PK	-24.6	20.7	24.34	46	-21.66	251	Horz
863.1455	26.97	PK	-24.3	21.6	24.27	46	-21.73	176	Horz
Range: 2 30 - 1000MHz									
Test Frequency	Meter Reading	Detector	25MHz-1GHz Chambr 3m Amplified [dB]	3m Bilog T185 below 1GHz.TXT [dB]	dBuV/m	CFR 47 Part 15 Class B 3m	Margin	Height [cm]	Polarity
31.7446	27.17	PK	-27.5	19.1	18.77	40	-21.23	101	Vert
124.4025	27.26	PK	-26.5	14.1	14.86	43.5	-28.64	101	Vert
145.1439	28.14	PK	-26.4	12.9	14.64	43.5	-28.86	101	Vert
158.1315	27.43	PK	-26.2	13.1	14.33	43.5	-29.17	175	Vert
214.5404	29.97	PK	-25.7	11.9	16.17	43.5	-27.33	250	Vert
518.2954	29.94	PK	-25.9	17.1	21.14	46	-24.86	101	Vert
243.4233	29.95	PK	-25.5	11.8	16.25	46	-29.75	175	Vert
958.5172	26.27	PK	-23.6	22.4	25.07	46	-20.93	250	Vert

### 8.4. RX SPURIOUS EMISSIONS ABOVE 1 GHz

**High Frequency Measurement**  
 Compliance Certification Services, Fremont 5m Chamber

Company: Anaren  
 Project #: 11U13980  
 Date: 12/13/2011  
 Test Engineer: William Zhuang  
 Configuration: EUT AND SUPPORT EQUIPMENT  
 Mode: RX MODE

**Test Equipment:**

<b>Horn 1-18GHz</b>	<b>Pre-amplifier 1-26GHz</b>	<b>Pre-amplifier 26-40GHz</b>	<b>Horn &gt; 18GHz</b>	<b>Limit</b>
T73; S/N: 6717 @3m	T144 Miteq 3008A00931			RX RSS 210

Hi Frequency Cables

<b>3' cable 22807700</b>	<b>12' cable 22807600</b>	<b>20' cable 22807500</b>	<b>HPF</b>	<b>Reject Filter</b>	<b>Peak Measurements</b> RBW=VBW=1MHz
3' cable 22807700	12' cable 22807600	20' cable 22807500			<b>Average Measurements</b> RBW=1MHz ; VBW=10Hz

f GHz	Dist (m)	Read Pk dBuV	Read Avg dBuV	AF dB/m	CL dB	Amp dB	D Corr dB	Fltr dB	Peak dBuV/m	Avg dBuV/m	Pk Lim dBuV/m	Avg Lim dBuV/m	Pk Mar dB	Avg Mar dB	Notes (V/H)
1.092	3.0	53.4	35.4	24.2	2.5	-39.4	0.0	0.0	40.7	22.6	74	54	-33.3	-31.4	H
1.400	3.0	51.2	35.0	25.2	2.8	-38.9	0.0	0.0	40.3	24.1	74	54	-33.7	-29.9	H
1.600	3.0	48.0	33.5	25.9	3.0	-38.6	0.0	0.0	38.2	23.7	74	54	-35.8	-30.3	H
1.092	3.0	61.7	37.9	24.2	2.5	-39.4	0.0	0.0	49.0	25.2	74	54	-25.0	-28.8	V
1.400	3.0	57.8	38.3	25.2	2.8	-38.9	0.0	0.0	46.9	27.4	74	54	-27.1	-26.6	V
1.600	3.0	58.3	39.2	25.9	3.0	-38.6	0.0	0.0	48.6	29.5	74	54	-25.4	-24.5	V

Rev. 07.22.09

f	Measurement Frequency	Amp	Preamp Gain	Avg Lim	Average Field Strength Limit
Dist	Distance to Antenna	D Corr	Distance Correct to 3 meters	Pk Lim	Peak Field Strength Limit
Read	Analyzer Reading	Avg	Average Field Strength @ 3 m	Avg Mar	Margin vs. Average Limit
AF	Antenna Factor	Peak	Calculated Peak Field Strength	Pk Mar	Margin vs. Peak Limit
CL	Cable Loss	HPF	High Pass Filter		

## 9. AC POWER LINE CONDUCTED EMISSIONS

### LIMITS

FCC §15.207 (a)

RSS-Gen 7.2.2

Frequency of Emission (MHz)	Conducted Limit (dBuV)	
	Quasi-peak	Average
0.15-0.5	66 to 56*	56 to 46*
0.5-5	56	46
5-30	60	50

\*Decreases with the logarithm of the frequency.

### TEST PROCEDURE

ANSI C63.4

**RESULTS**

**6 WORST EMISSIONS (WORST CASE)**

Project: 11U13980									
Model: A8520E24A91									
EUT with Laptop & AC/DC Adapter									
Line-L1 .15 - 30MHz									
Test Frequency	Meter Reading	Detector	T24 IL L1.TXT [dB]	LC Cables 1&3.TXT [dB]	dBuV	CISPR Class B QP	Margin	CISPR Class B Avg	Margin
0.1545	55.23	PK	0.1	0	55.33	65.8	-10.47	-	-
0.1545	41.95	Av	0.1	0	42.05	-	-	55.8	-13.75
0.6315	39.89	PK	0.1	0	39.99	56	-16.01	-	-
0.6315	27.27	Av	0.1	0	27.37	-	-	46	-18.63
2.976	36.6	PK	0.1	0.1	36.8	56	-19.2	-	-
2.976	22.51	Av	0.1	0.1	22.71	-	-	46	-23.29
24.1935	29.48	PK	0.4	0.3	30.18	60	-29.82	-	-
24.1935	27.04	Av	0.4	0.3	27.74	-	-	50	-22.26
29.23575	28.14	PK	0.5	0.3	28.94	60	-31.06	-	-
29.23575	23.06	Av	0.5	0.3	23.86	-	-	50	-26.14
Line-L2 .15 - 30MHz									
Test Frequency	Meter Reading	Detector	T24 IL L2.TXT [dB]	LC Cables 2&3.TXT [dB]	dBuV	CISPR Class B QP	Margin	CISPR Class B Avg	Margin
0.177	48.52	PK	0.1	0	48.62	64.6	-15.98	-	-
0.177	26.03	Av	0.1	0	26.13	-	-	54.6	-28.47
0.6495	39.48	PK	0.1	0	39.58	56	-16.42	-	-
0.6495	27.43	Av	0.1	0	27.53	-	-	46	-18.47
1.6215	37.98	PK	0.1	0.1	38.18	56	-17.82	-	-
1.6215	20.66	Av	0.1	0.1	20.86	-	-	46	-25.14
3.4305	35.77	PK	0.1	0.1	35.97	56	-20.03	-	-
3.4305	18.88	Av	0.1	0.1	19.08	-	-	46	-26.92
Project: 11U13980									
Model: A8520E24A91									
EUT with Laptop & AC/DC Adapter									

**LINE 1 RESULTS**

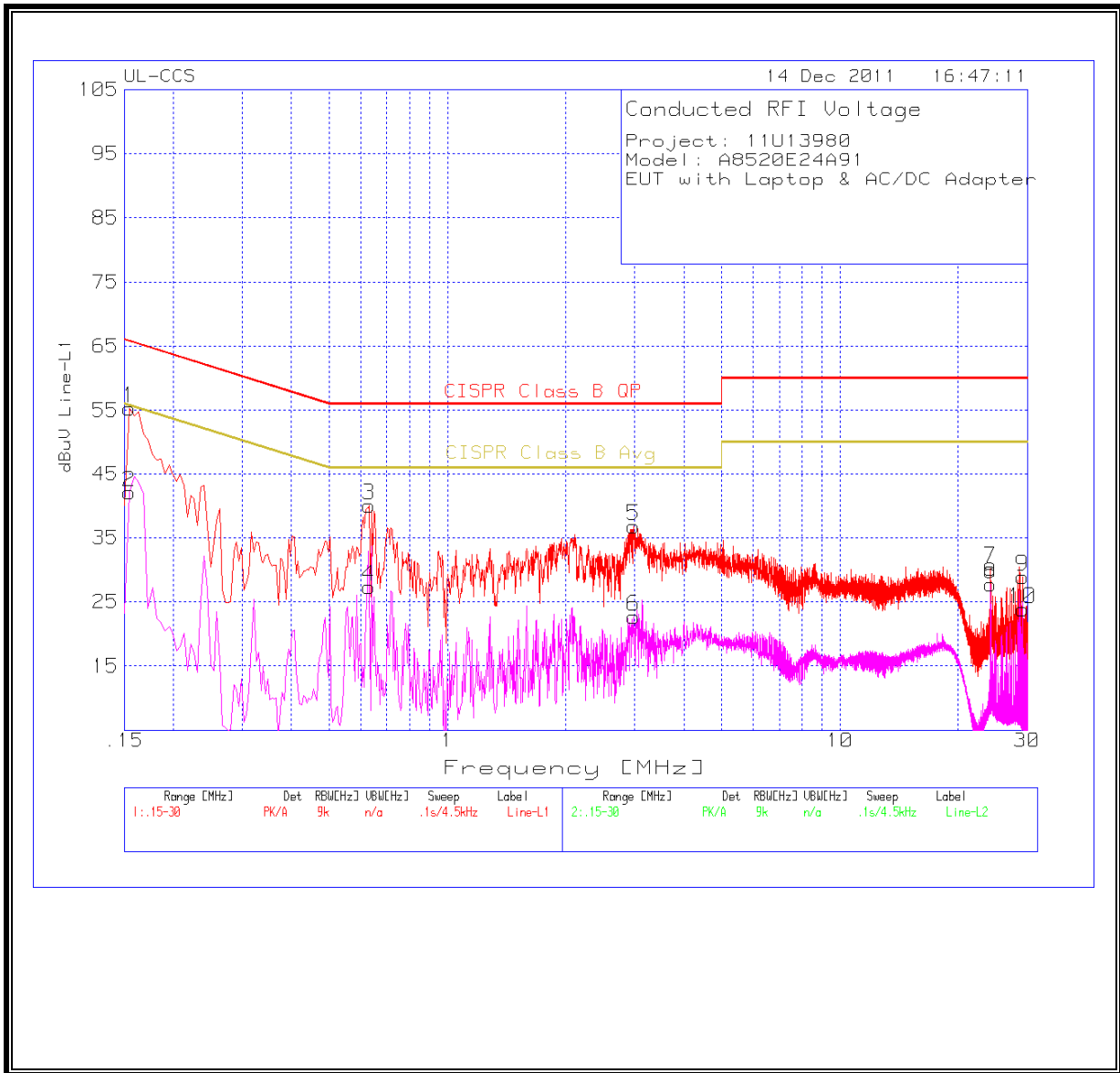



**LINE 2 RESULTS**

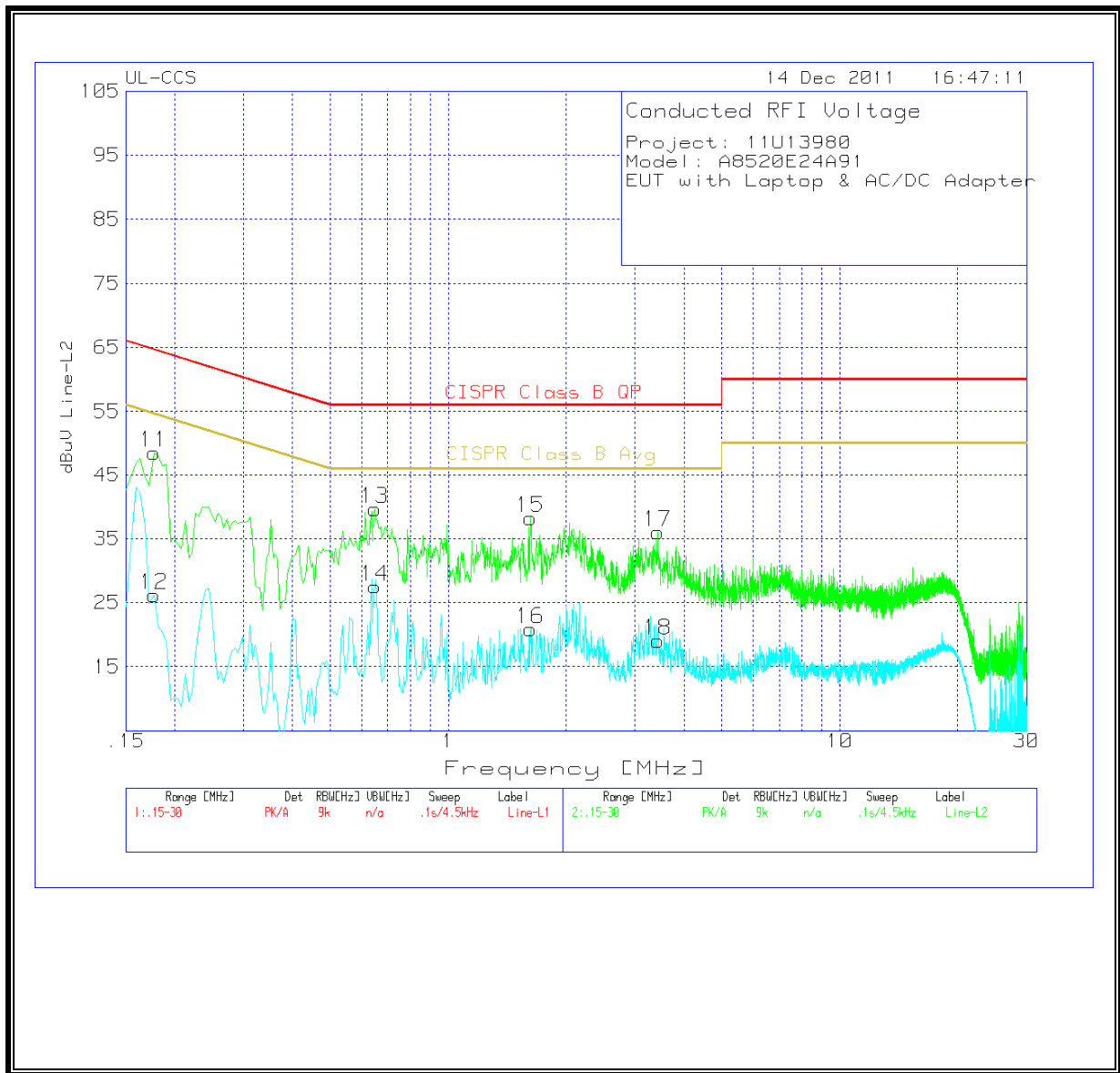

## 10. MAXIMUM PERMISSIBLE EXPOSURE

### FCC RULES

§1.1310 The criteria listed in Table 1 shall be used to evaluate the environmental impact of human exposure to radio-frequency (RF) radiation as specified in §1.1307(b), except in the case of portable devices which shall be evaluated according to the provisions of §2.1093 of this chapter.

TABLE 1—LIMITS FOR MAXIMUM PERMISSIBLE EXPOSURE (MPE)

Frequency range (MHz)	Electric field strength (V/m)	Magnetic field strength (A/m)	Power density (mW/cm <sup>2</sup> )	Averaging time (minutes)
(A) Limits for Occupational/Controlled Exposures				
0.3–3.0 .....	614	1.63	*(100)	6
3.0–30 .....	1842/f	4.89/f	*(900/f <sup>2</sup> )	6
30–300 .....	61.4	0.163	1.0	6
300–1500 .....	.....	.....	f/300	6
1500–100,000 .....	.....	.....	5	6
(B) Limits for General Population/Uncontrolled Exposure				
0.3–1.34 .....	614	1.63	*(100)	30
1.34–30 .....	824/f	2.19/f	*(180/f <sup>2</sup> )	30

TABLE 1—LIMITS FOR MAXIMUM PERMISSIBLE EXPOSURE (MPE)—Continued

Frequency range (MHz)	Electric field strength (V/m)	Magnetic field strength (A/m)	Power density (mW/cm <sup>2</sup> )	Averaging time (minutes)
30–300 .....	27.5	0.073	0.2	30
300–1500 .....	.....	.....	f/1500	30
1500–100,000 .....	.....	.....	1.0	30

f = frequency in MHz

\* = Plane-wave equivalent power density

NOTE 1 TO TABLE 1: Occupational/controlled limits apply in situations in which persons are exposed as a consequence of their employment provided those persons are fully aware of the potential for exposure and can exercise control over their exposure. Limits for occupational/controlled exposure also apply in situations when an individual is transient through a location where occupational/controlled limits apply provided he or she is made aware of the potential for exposure.

NOTE 2 TO TABLE 1: General population/uncontrolled exposures apply in situations in which the general public may be exposed, or in which persons that are exposed as a consequence of their employment may not be fully aware of the potential for exposure or can not exercise control over their exposure.

**IC RULES**

IC Safety Code 6, Section 2.2.1 (a) A person other than an RF and microwave exposed worker shall not be exposed to electromagnetic radiation in a frequency band listed in Column 1 of Table 5, if the field strength exceeds the value given in Column 2 or 3 of Table 5, when averaged spatially and over time, or if the power density exceeds the value given in Column 4 of Table 5, when averaged spatially and over time.

**Table 5  
 Exposure Limits for Persons Not Classed As RF and Microwave Exposed Workers (Including the General Public)**

1 Frequency (MHz)	2 Electric Field Strength; rms (V/m)	3 Magnetic Field Strength; rms (A/m)	4 Power Density (W/m <sup>2</sup> )	5 Averaging Time (min)
0.003–1	280	2.19		6
1–10	280/ <i>f</i>	2.19/ <i>f</i>		6
10–30	28	2.19/ <i>f</i>		6
30–300	28	0.073	2*	6
300–1 500	1.585 <i>f</i> <sup>0.5</sup>	0.0042 <i>f</i> <sup>0.5</sup>	<i>f</i> /150	6
1 500–15 000	61.4	0.163	10	6
15 000–150 000	61.4	0.163	10	616 000 / <i>f</i> <sup>1.2</sup>
150 000–300 000	0.158 <i>f</i> <sup>0.5</sup>	4.21 x 10 <sup>-4</sup> <i>f</i> <sup>0.5</sup>	6.67 x 10 <sup>-5</sup> <i>f</i>	616 000 / <i>f</i> <sup>1.2</sup>

\* Power density limit is applicable at frequencies greater than 100 MHz.

- Notes:**
1. Frequency, *f*, is in MHz.
  2. A power density of 10 W/m<sup>2</sup> is equivalent to 1 mW/cm<sup>2</sup>.
  3. A magnetic field strength of 1 A/m corresponds to 1.257 microtesla (μT) or 12.57 milligauss (mG).

## **EQUATIONS**

Power density is given by:

$$S = \text{EIRP} / (4 * \text{Pi} * \text{D}^2)$$

where

S = Power density in W/m<sup>2</sup>

EIRP = Equivalent Isotropic Radiated Power in W

D = Separation distance in m

Power density in units of W/m<sup>2</sup> is converted to units of mW/cm<sup>2</sup> by dividing by 10.

Distance is given by:

$$D = \text{SQRT} (\text{EIRP} / (4 * \text{Pi} * S))$$

where

D = Separation distance in m

EIRP = Equivalent Isotropic Radiated Power in W

S = Power density in W/m<sup>2</sup>

For multiple colocated transmitters operating simultaneously in frequency bands where the limit is identical, the total power density is calculated using the total EIRP obtained by summing the Power \* Gain product (in linear units) of each transmitter.

$$\text{Total EIRP} = (P1 * G1) + (P2 * G2) + \dots + (Pn * Gn)$$

where

Px = Power of transmitter x

Gx = Numeric gain of antenna x

In the table(s) below, Power and Gain are entered in units of dBm and dBi respectively and conversions to linear forms are used for the calculations.

## **LIMITS**

From FCC §1.1310 Table 1 (B), the maximum value of S = 1.0 mW/cm<sup>2</sup>

From IC Safety Code 6, Section 2.2 Table 5 Column 4, S = 10 W/m<sup>2</sup>

**RESULTS**

Band	Mode	Separation Distance (m)	Output AV Power (dBm)	Antenna Gain (dBi)	IC Power Density (W/m <sup>2</sup> )	FCC Power Density (mW/cm <sup>2</sup> )
2.4 GHz	QPSK	0.20	17.71	2.00	0.19	0.019