

change

TITLE: New Thinking Tek.LTD		File NO:
MODEL: GS503		Drawing NO:
BASEBAND		
VER: 1.1	STANDARD:	
DESIGN: PZJ	CHECK:	
		APPROVE:

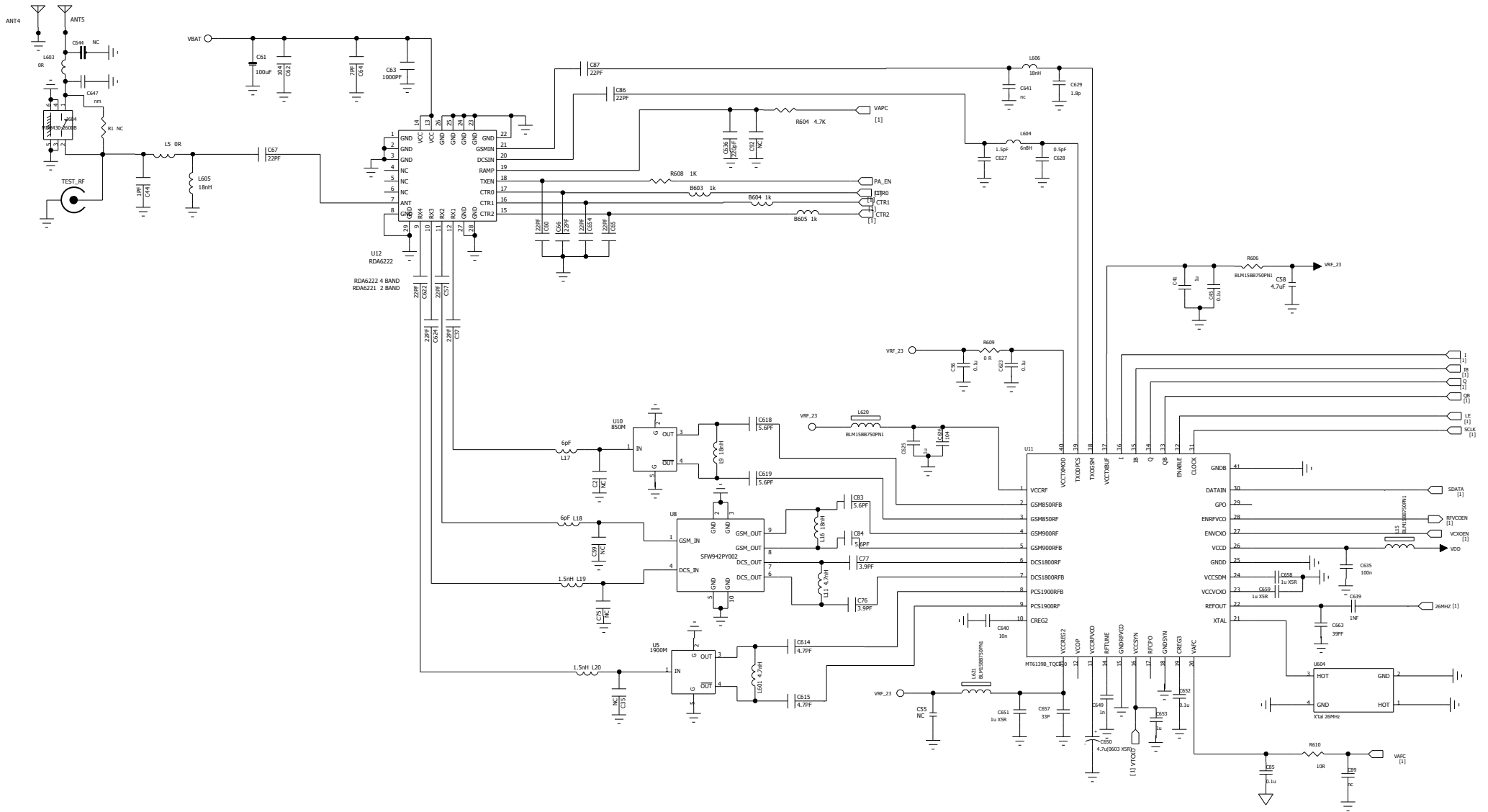

New Thinking Tek.LTD		File NO:
MODEL: GSS03		Drawing NO:
RF UNIT		STANDARD:
VER: 1.1		CHECK:
DESIGN: PZJ		APPROVE:

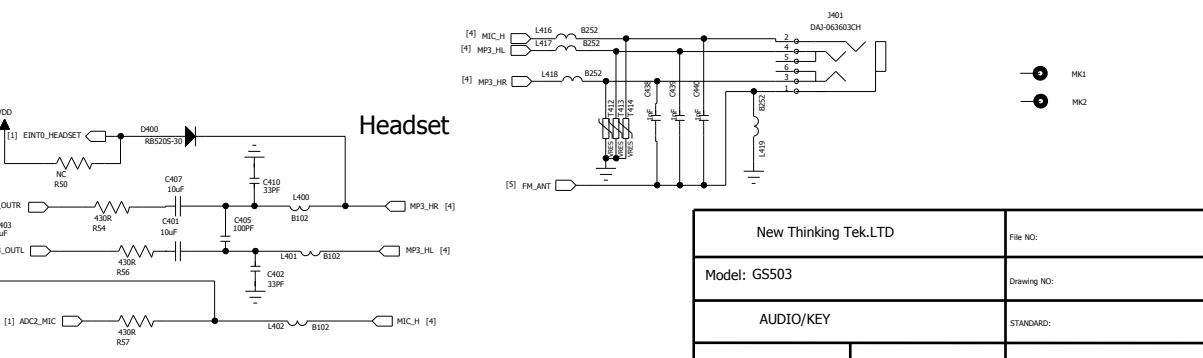
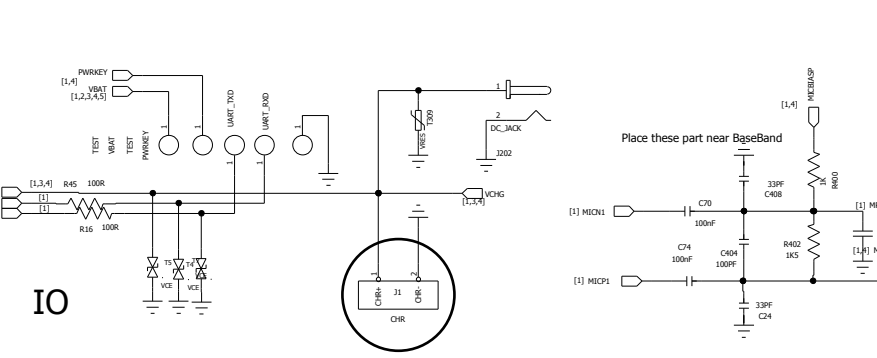
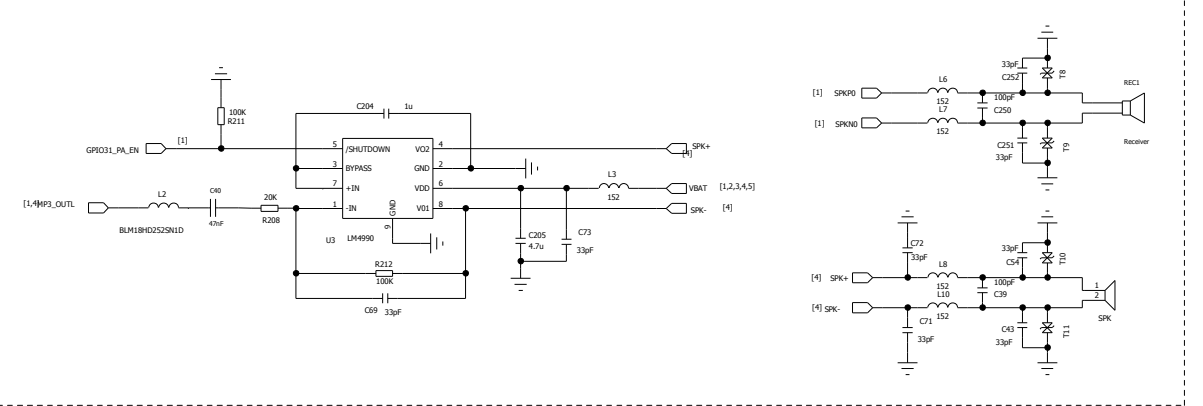
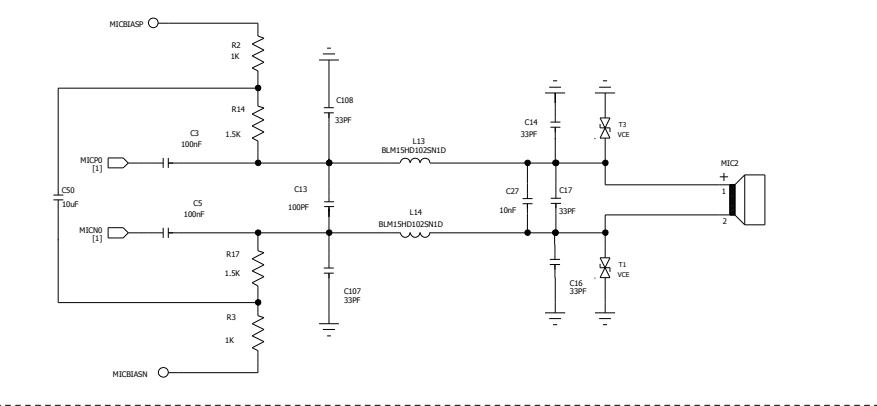
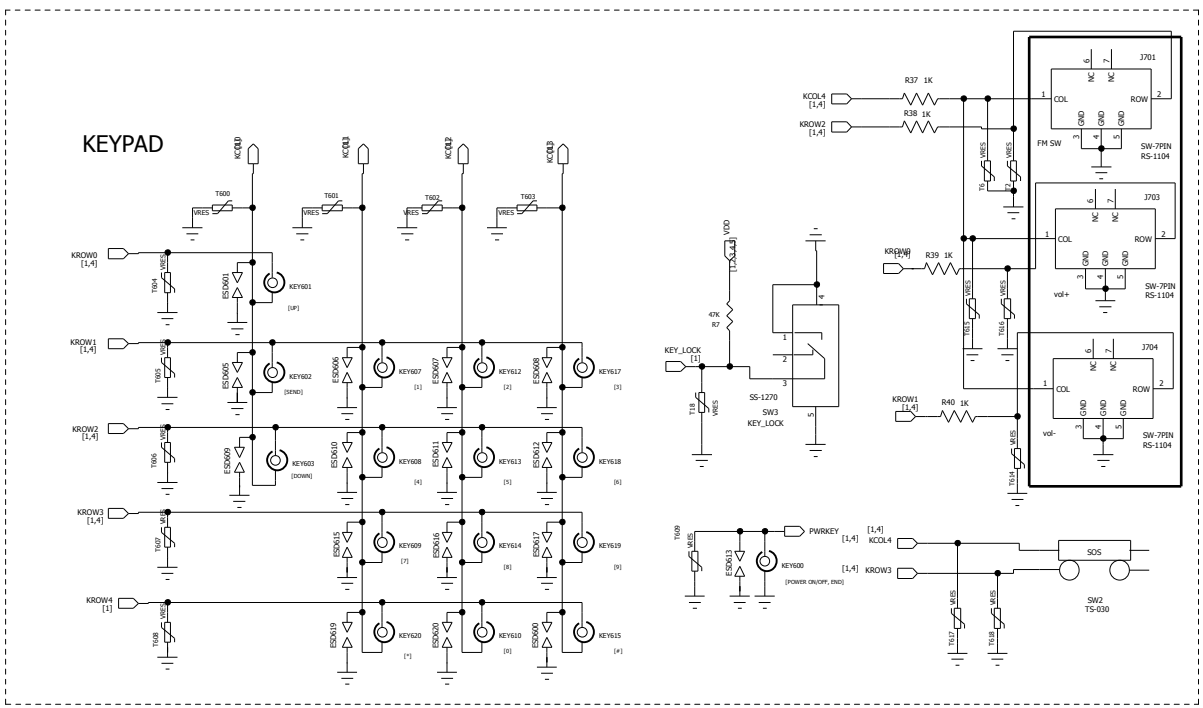
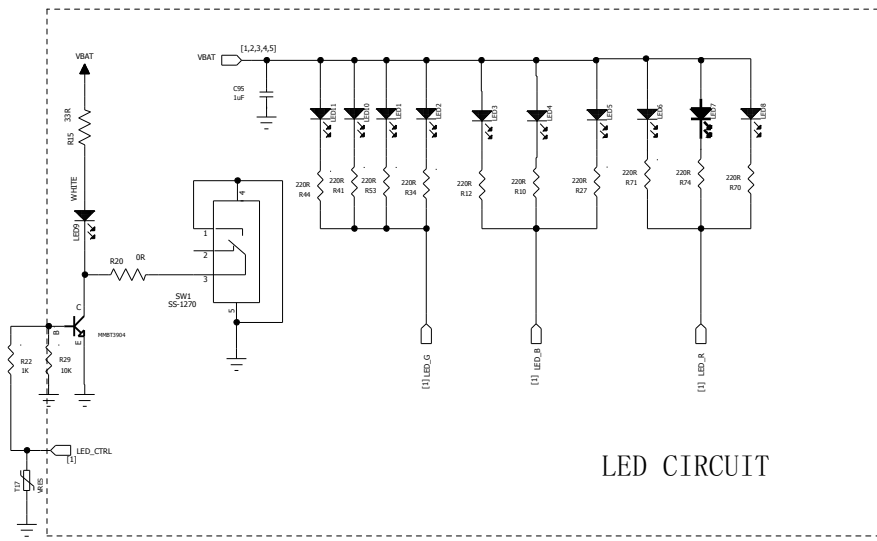

New Thinking Tek.LTD		File NO:
Model: GS503		Drawing NO:
AUDIO/KEY		STANDARD:
VER: 1.1	PCB:	CHECK:
DESIGN: PZJ		APPROVE:

