

## SAR TEST REPORT

For

Shenzhen Concox Information Technology Co.,Ltd

Personal GPS Tracker

Model No.: GK310

Additional Model No.: ILW01 Z

Prepared for : Shenzhen Concox Information Technology Co.,Ltd  
Address : 4/F.Building C, Gaoxinqi Industrial Park, Liuxian 1st Road,  
No,67 Bao'an District, Shenzhen ,P.R.China

Prepared by : Shenzhen LCS Compliance Testing Laboratory Ltd.  
Address : 1/F., Xingyuan Industrial Park, Tongda Road, Bao'an Avenue,  
Bao'an District, Shenzhen, Guangdong, China

Tel : (86)755-82591330  
Fax : (86)755-82591332  
Web : www.LCS-cert.com  
Mail : webmaster@LCS-cert.com

Date of receipt of test sample : October 09, 2017  
Number of tested samples : 1  
Serial number : Prototype  
Date of Test : October 11, 2017~October 13, 2017  
Date of Report : October 29, 2017

**SAR TEST REPORT****Report Reference No.** ..... : **LCS170928031AE4**

Date Of Issue ..... : October 29, 2017

**Testing Laboratory Name**..... : **Shenzhen LCS Compliance Testing Laboratory Ltd.**

Address ..... : 1/F., Xingyuan Industrial Park, Tongda Road, Bao'an Avenue, Bao'an District, Shenzhen, Guangdong, China

Testing Location/ Procedure ..... : Full application of Harmonised standards   
Partial application of Harmonised standards   
Other standard testing method **Applicant's Name** ..... : **Shenzhen Concox Information Technology Co.,Ltd**

Address ..... : 4/F. Building C, Gaoxinqi Industrial Park, Liuxian 1st Road, No.67 Bao'an District, Shenzhen ,P.R.China

**Test Specification:**Standard..... : IEEE 1528:2013/KDB865664  
47CFR §2.1093

Test Report Form No. .... : LCSEMC-1.0

TRF Originator..... : Shenzhen LCS Compliance Testing Laboratory Ltd.

Master TRF ..... : Dated 2014-09

**Shenzhen LCS Compliance Testing Laboratory Ltd. All rights reserved.**

This publication may be reproduced in whole or in part for non-commercial purposes as long as the Shenzhen LCS Compliance Testing Laboratory Ltd. is acknowledged as copyright owner and source of the material. Shenzhen LCS Compliance Testing Laboratory Ltd. takes no responsibility for and will not assume liability for damages resulting from the reader's interpretation of the reproduced material due to its placement and context.

**Test Item Description**..... : **Personal GPS Tracker**

Trade Mark ..... : N/A

Model/Type Reference..... : GK310

Operation Frequency ..... : GSM 850/PCS1900, WCDMA Band II/V, LTE Band2/4

Modulation Type..... : GSM(GMSK,8PSK), WCDMA/HSDPA/HSUPA(QPSK),  
LTE(QPSK,16QAM)

DC 3.8V, 1500mAh

Ratings ..... : Charging parameter: Input: 100~240V AC, 50/60Hz, 0.2A;

Output: DC 5V, 1A

**Result** ..... : **Positive****Compiled by:***Irene Liu*

Irene Liu / File administrators

**Supervised by:***Dick Su*

Dick Su / Technique principal

**Approved by:***Gavin Liang*

Gavin Liang/ Manager

# SAR -- TEST REPORT

<b>Test Report No. :</b> <b>LCS170928031AE4</b>	<u>October 29, 2017</u> Date of issue
---	--

Type / Model.....	: GK310
EUT.....	: Personal GPS Tracker
<b>Applicant.....</b>	<b>: Shenzhen Concox Information Technology Co.,Ltd</b>
Address.....	: 4/F.Building C, Gaoxinqi Industrial Park, Liuxian 1st Road, No,67 Bao'an District, Shenzhen ,P.R.China
Telephone.....	: /
Fax.....	: /
<b>Manufacturer.....</b>	<b>: Shenzhen Concox Information Technology Co.,Ltd</b>
Address.....	: 4/F.Building C, Gaoxinqi Industrial Park, Liuxian 1st Road, No,67 Bao'an District, Shenzhen ,P.R.China
Telephone.....	: /
Fax.....	: /
<b>Factory.....</b>	<b>: Shenzhen Concox Information Technology Co.,Ltd</b>
Address.....	: 4/F.Building C, Gaoxinqi Industrial Park, Liuxian 1st Road, No,67 Bao'an District, Shenzhen ,P.R.China
Telephone.....	: /
Fax.....	: /

<b>Test Result</b>	<b>Positive</b>
--------------------	-----------------

The test report merely corresponds to the test sample.  
It is not permitted to copy extracts of these test result without the written permission of the test laboratory.

### Revision History

Revision	Issue Date	Revisions	Revised By
00	October 29, 2017	Initial Issue	Gavin Liang

## TABLE OF CONTENTS

<b>1. TEST STANDARDS AND TEST DESCRIPTION.....</b>	<b>6</b>
1.1. TEST STANDARDS .....	6
1.2. TEST DESCRIPTION.....	6
1.3. GENERAL REMARKS .....	6
1.4. PRODUCT DESCRIPTION .....	6
1.5. STATEMENT OF COMPLIANCE .....	7
<b>2. TEST ENVIRONMENT .....</b>	<b>8</b>
2.1. TEST FACILITY.....	8
2.2. ENVIRONMENTAL CONDITIONS .....	8
2.3. SAR LIMITS .....	8
2.4. EQUIPMENTS USED DURING THE TEST .....	9
<b>3. SAR MEASUREMENTS SYSTEM CONFIGURATION .....</b>	<b>10</b>
3.1. SARMEASUREMENT SET-UP.....	10
3.2. OPENSAR E-FIELD PROBE SYSTEM.....	11
3.3. PHANTOMS.....	12
3.4. DEVICE HOLDER .....	12
3.5. SCANNING PROCEDURE .....	13
3.6. DATA STORAGE AND EVALUATION.....	14
3.7. POSITION OF THE WIRELESS DEVICE IN RELATION TO THE PHANTOM.....	15
3.8. TISSUE DIELECTRIC PARAMETERS FOR HEAD AND BODY PHANTOMS .....	17
3.9. TISSUE EQUIVALENT LIQUID PROPERTIES .....	17
3.10. SYSTEM CHECK .....	18
3.11. SAR MEASUREMENT PROCEDURE .....	19
3.12. POWER REDUCTION .....	22
3.13. POWER DRIFT .....	22
<b>4. TEST CONDITIONS AND RESULTS.....</b>	<b>23</b>
4.1. CONDUCTED POWER RESULTS .....	23
4.2. MANUFACTURING TOLERANCE .....	31
4.3. TRANSMIT ANTENNAS AND SAR MEASUREMENT POSITION.....	35
4.4. SAR MEASUREMENT RESULTS .....	36
4.5. SAR MEASUREMENT VARIABILITY .....	39
4.6. GENERAL DESCRIPTION OF TEST PROCEDURES .....	39
4.7. MEASUREMENT UNCERTAINTY (300MHZ-3GHZ).....	40
4.8. SYSTEM CHECK RESULTS .....	41
4.10 SAR TEST GRAPH RESULTS .....	44
<b>5. CALIBRATION CERTIFICATES .....</b>	<b>50</b>
5.1 PROBE-EPGO281 CALIBRATION CERTIFICATE.....	50
5.2 SID835DIPOLE CALIBRATION CERITICATE.....	60
5.3 SID1800 DIPOLE CALIBRATION CERTIFICATE .....	71
5.4 SID1900 DIPOLE CALIBRATION CERTIFICATE.....	82
<b>6. EUT TEST PHOTOGRAPHS .....</b>	<b>93</b>
6.1 PHOTOGRAPH OF LIQUID DEPTH.....	93
6.2 PHOTOGRAPH OF THE TEST .....	95
<b>7. EUT PHOTOGRAPHS .....</b>	<b>97</b>

# 1. TEST STANDARDS AND TEST DESCRIPTION

## 1.1. Test Standards

[IEEE Std C95.1, 2005](#): IEEE Standard for Safety Levels with Respect to Human Exposure to Radio Frequency Electromagnetic Fields, 3 KHz to 300 GHz. It specifies the maximum exposure limit of 1.6 W/kg as averaged over any 1 gram of tissue for portable devices being used within 20 cm of the user in the uncontrolled environment.

[IEEE Std 1528™-2013](#): IEEE Recommended Practice for Determining the Peak Spatial-Average Specific Absorption Rate (SAR) in the Human Head from Wireless Communications Devices: Measurement Techniques.

[FCC Part 2.1093](#) Radiofrequency Radiation Exposure Evaluation: Portable Devices

[KDB447498 D01 General RF Exposure Guidance](#) : Mobile and Portable Device RF Exposure Procedures and Equipment Authorization Policies

[KDB648474 D04](#): Handset SAR v01r03: SAR Evaluation Considerations for Wireless Handsets

[KDB865664 D01 SAR Measurement 100 MHz to 6 GHz](#) : SAR Measurement Requirements for 100 MHz to 6 GHz

[KDB865664 D02 RF Exposure Reporting](#): RF Exposure Compliance Reporting and Documentation Considerations

[KDB941225 D01 3G SAR Procedures](#): 3G SAR MEAUREMENT PROCEDURES

[941225 D07 UMPC Mini Tablet v01r02](#): SAR EVALUATION PROCEDURES FOR UMPC MINI-TABLET DEVICES

[KDB 941225 D05 SAR for LTE Devices](#): SAR Evaluation Considerations for LTE Devices

## 1.2. Test Description

The EUT battery must be fully charged and checked periodically during the test to ascertain uniform power . And Test device is identical prototype.

## 1.3. General Remarks

Date of receipt of test sample	:	October 09, 2017
Testing commenced on	:	October 11, 2017
Testing concluded on	:	October 13, 2017

## 1.4. Product Description

The **Shenzhen Concox Information Technology Co.,Ltd.**'s Model: **GK310** or the "EUT" as referred to in this report; more general information as follows, for more details, refer to the user's manual of the EUT.

General Description	
Product Name:	Personal GPS Tracker
Model/Type reference:	GK310
Listed Model(s):	/
Modulation Type:	GMSK for GSM/GPRS, 8-PSK for EDGE,QPSK for UMTS, QPSK, 16QAM for LTE
Device category:	Portable Device
Exposure category:	General population/uncontrolled environment
EUT Type:	Production Unit
Hardware Version	KH3709_V1.2
Software Version:	GK310_11_M35_R0_V01_US
Power supply:	DC 3.8V, 1500mAh Charging parameter: Input: 100~240V AC, 50/60Hz, 0.2A; Output: DC 5V, 1A
Hotspot:	-/-
VoIP	-/-
<p><i>The EUT is GSM,WCDMA,LTE, Personal GPS Tracker. the Personal GPS Tracker is intended for Multimedia Message Service (MMS) transmission. It is equipped with GPRS/EDGE class 12 for GSM850, PCS1900, WCDMA Band II, Band V, LTE Band 2, Band 4 and GPS functions. For more information see the following datasheet</i></p>	

Technical Characteristics	
<b>GSM</b>	
Support Networks	GPRS, EDGE
Support Band	GSM850, PCS1900
Frequency	GSM850: 824.2~848.8MHz GSM1900: 1850.2~1909.8MHz
Power Class:	GSM850:Power Class 4 PCS1900:Power Class 1
Modulation Type:	GMSK for GSM/GPRS; GMSK/8PSK For EGPRS
Antenna Information	PIFA Antenna 1.21dBi (max.) For GSM 850; 1.21dBi (max.) For PCS 1900
GSM Release Version	R99
GPRS Multislot Class	12
EGPRS Multislot Class	12
DTM Mode	Not Supported
<b>UMTS</b>	
Support Networks	WCDMA RMC12.2K,HSDPA,HSUPA
Operation Band:	WCDMA Band II, Band V
Frequency Range	WCDMA Band II: 1852.4 ~ 1907.6MHz WCDMA Band V: 826.4 ~ 846.6MHz
Modulation Type:	QPSK for WCDMA/HSUPA/HSDPA
Power Class:	Class 3
WCDMA Release Version:	R99
HSDPA Release Version:	R8
HSUPA Release Version:	R6
DC-HSUPA Release Version:	Not Supported
Antenna Information	PIFA Antenna 1.21dBi (max.) For WCDMA Band II 1.21dBi (max.) For WCDMA Band V
<b>LTE</b>	
Support Band	LTE Band2, Band4
Frequency Range	LTE Band2:1850 ~ 1910MHz LTE Band4:1710 ~ 1755MHz
Power Class:	Class 3
Modulation Type:	QPSK/16QAM
LTE Release Version:	R9
VoLTE	Not Support
Antenna Information	PIFA Antenna, 1.21dBi (max.) For LTE FDD Band 2; 1.21dBi (max.) For LTE FDD Band 4;

## 1.5. Statement of Compliance

The maximum of results of SAR found during testing for GK310 are follows:

<Highest Reported standalone SAR Summary>

Classment Class	Frequency Band	Body-worn (Report SAR <sub>1-g</sub> (W/Kg))
PCB	GSM 850	1.236
	GSM1900	0.795
	WCDMA Band V	1.092
	WCDMA Band II	0.742
	LTE Band 2	0.678
	LTE Band 4	0.774

This device is in compliance with Specific Absorption Rate (SAR) for general population/uncontrolled exposure limits (1.6 W/kg) specified in FCC 47 CFR part 2 (2.1093) and ANSI/IEEE C95.1-2005, and had been tested in accordance with the measurement methods and procedures specified in IEEE 1528-2013.

## 2. TEST ENVIRONMENT

### 2.1. Test Facility

The test facility is recognized, certified, or accredited by the following organizations:

Site Description  
EMC Lab. : CNAS Registration Number. is L4595.  
FCC Registration Number. is 254912  
Industry Canada Registration Number. is 9642A-1.  
ESMD Registration Number. is ARCB0108.  
UL Registration Number. is 100571-492.  
TUV SUD Registration Number. is SCN1081.  
TUV RH Registration Number. is UA 50296516-001  
NVLAP Registration Code is 600167-0.

### 2.2. Environmental conditions

During the measurement the environmental conditions were within the listed ranges:

Temperature:	18-25 ° C
Humidity:	40-65 %
Atmospheric pressure:	950-1050mbar

### 2.3. SAR Limits

EXPOSURE LIMITS	FCC Limit (1g Tissue)	
	(General Population / Uncontrolled Exposure Environment)	(Occupational / Controlled Exposure Environment)
Spatial Average(averaged over the whole body)	0.08	0.4
Spatial Peak(averaged over any 1 g of tissue)	1.6	8.0
Spatial Peak(hands/wrists/ feet/anklesaveraged over 10 g)	4.0	20.0

Population/Uncontrolled Environments are defined as locations where there is the exposure of individual who have no knowledge or control of their exposure.

Occupational/Controlled Environments are defined as locations where there is exposure that may be incurred by people who are aware of the potential for exposure (i.e. as a result of employment or occupation).



## 2.4. Equipments Used during the Test

Test Equipment	Manufacturer	Type/Model	Serial Number	Calibration	
				Calibration Date	Calibration Due
PC	Lenovo	G5005	MY42081102	N/A	N/A
SAR Measurement system	SATIMO	4014_01	SAR_4014_01	N/A	N/A
Signal Generator	Agilent	E4438C	MY42081396	11/18/2016	11/17/2017
Multimeter	Keithley	MiltiMeter 2000	4059164	11/18/2016	11/17/2017
S-parameter Network Analyzer	Agilent	8753ES	US38432944	11/18/2016	11/17/2017
Wireless Communication Test Set	R & S	CMU200	105988	11/18/2016	11/17/2017
Wideband Radia Communication Tester	R&S	CMW500	1201.0002K50	11/18/2016	11/17/2017
Power Meter	R & S	KEITHLEY	4059164	11/18/2016	11/17/2017
E-Field PROBE	SATIMO	SSE2	SN 45/15 EPGO281	02/04/2017	02/03/2018
DIPOLE 835	SATIMO	SID 835	SN 07/14 DIP 0G835-303	10/01/2015	09/30/2018
DIPOLE 1800	SATIMO	SID 1800	SN 07/14 DIP 1G800-301	10/01/2015	09/30/2018
DIPOLE 1900	SATIMO	SID 1900	SN 30/14 DIP 1G900-333	10/01/2015	09/30/2018
COMOSAR OPEN Coaxial Probe	SATIMO	OCPG 68	SN 40/14 OCPG68	11/18/2016	11/17/2017
SAR Locator	SATIMO	VPS51	SN 40/14 VPS51	11/18/2016	11/17/2017
Communication Antenna	SATIMO	ANTA57	SN 39/14 ANTA57	11/18/2016	11/17/2017
Mobile Phone POSITIONING DEVICE	SATIMO	MSH98	SN 40/14 MSH98	N/A	N/A
DUMMY PROBE	SATIMO	DP60	SN 03/14 DP60	N/A	N/A
SAM PHANTOM	SATIMO	SAM117	SN 40/14 SAM117	N/A	N/A
Liquid measurement Kit	HP	85033D	3423A03482	11/18/2016	11/17/2017
Power meter	Agilent	E4419B	MY45104493	06/17/2017	06/16/2018
Power meter	Agilent	E4418B	GB4331256	06/17/2017	06/16/2018
Power sensor	Agilent	E9301H	MY41497725	06/17/2017	06/16/2018
Power sensor	Agilent	E9301H	MY41495234	06/17/2017	06/16/2018
Directional Coupler	MCLI/USA	4426-20	0D2L51502	06/17/2017	06/16/2018

### Note:

- 1) Per KDB865664D01 requirements for dipole calibration, the test laboratory has adopted three year extended calibration interval. Each measured dipole is expected to evaluate with following criteria at least on annual interval.
  - a) There is no physical damage on the dipole;
  - b) System check with specific dipole is within 10% of calibrated values;
  - c) The most recent return-loss results,measured at least annually,deviates by no more than 20% from the previous measurement;
  - d) The most recent measurement of the real or imaginary parts of the impedance, measured at least annually is within 5Ω from the previous measurement.
- 2) Network analyzer probe calibration against air, distilled water and a shorting block performed before measuring liquid parameters.

### 3. SAR MEASUREMENTS SYSTEM CONFIGURATION

#### 3.1. SAR Measurement Set-up

The OPENSAR system for performing compliance tests consist of the following items:

A standard high precision 6-axis robot (KUKA) with controller and software.

KUKA Control Panel (KCP)

A dosimetric probe, i.e., an isotropic E-field probe optimized and calibrated for usage in tissue simulating liquid. The probe is equipped with a Video Positioning System(VPS).

The stress sensor is composed with mechanical and electronic when the electronic part detects a change on the electro-mechanical switch,It sends an "Emergency signal" to the robot controller that to stop robot's moves

A computer operating Windows XP.

OPENSAR software

Remote control with teaches pendant and additional circuitry for robot safety such as warning lamps, etc.

The SAM phantom enabling testing left-hand right-hand and body usage.

The Position device for handheld EUT

Tissue simulating liquid mixed according to the given recipes .

System validation dipoles to validate the proper functioning of the system.

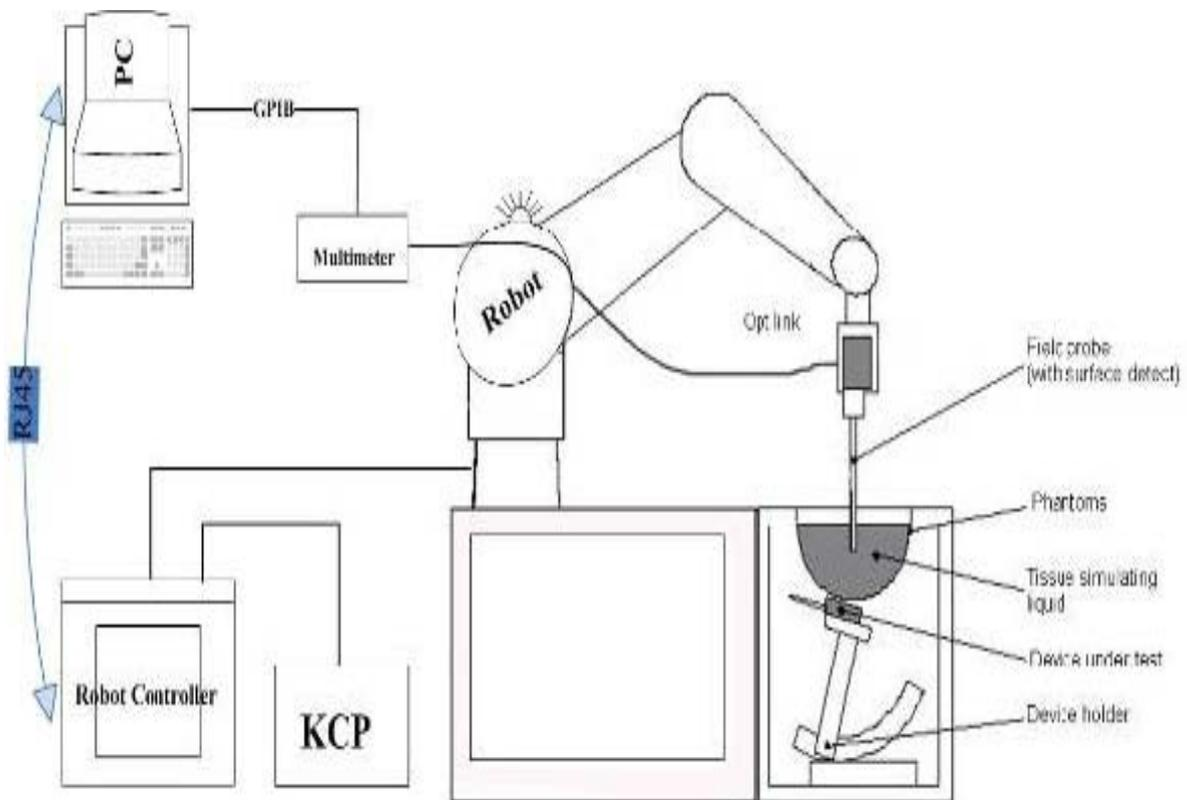

### 3.2. OPENSAR E-field Probe System

The SAR measurements were conducted with the dosimetric probe EP220 (manufactured by SATIMO), designed in the classical triangular configuration and optimized for dosimetric evaluation.

#### Probe Specification

Construction Symmetrical design with triangular core  
 Interleaved sensors  
 Built-in shielding against static charges  
 PEEK enclosure material (resistant to organic solvents, e.g., DGBE)

Calibration ISO/IEC 17025 calibration service available.

Frequency	700 MHz to 3 GHz; Linearity: 0.25dB(700 MHz to 3GHz)
Directivity	0.25 dB in HSL (rotation around probe axis) 0.5 dB in tissue material (rotation normal to probe axis)
Dynamic Range	0.01W/kg to > 100 W/kg; Linearity: 0.25 dB
Dimensions	Overall length: 330 mm (Tip: 16mm) Tip diameter: 5 mm (Body: 8 mm) Distance from probe tip to sensor centers: 2.5 mm
Application	General dosimetry up to 3 GHz Dosimetry in strong gradient fields Compliance tests of Mobile Phones



#### Isotropic E-Field Probe

The isotropic E-Field probe has been fully calibrated and assessed for isotropicity, and boundary effect within a controlled environment. Depending on the frequency for which the probe is calibrated the method utilized for calibration will change.

The E-Field probe utilizes a triangular sensor arrangement as detailed in the diagram below:

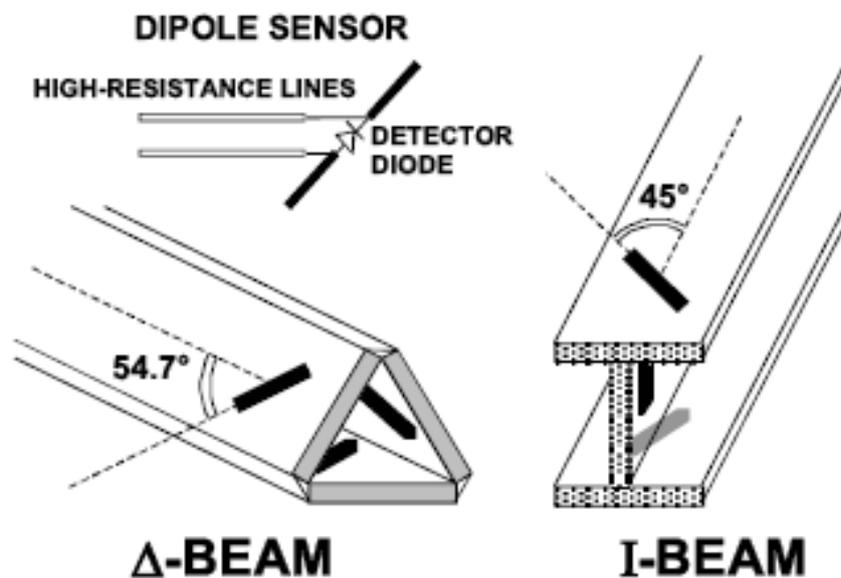

### 3.3. Phantoms

The SAM Phantom SAM117 is constructed of a fiberglass shell integrated in a wooden table. The shape of the shell is in compliance with the specification set in IEEE P1528 and CENELEC EN62209-1, EN62209-2:2010. The phantom enables the dosimetric evaluation of left and right hand phone usage as well as body mounted usage at the flat phantom region. A cover prevents the evaporation of the liquid. Reference markings on the Phantom allow the complete setup of all predefined phantom positions and measurement grids by manually teaching three points in the robot.

System checking was performed using the flat section, whilst Head SAR tests used the left and right head profile sections. Body SAR testing also used the flat section between the head profiles.

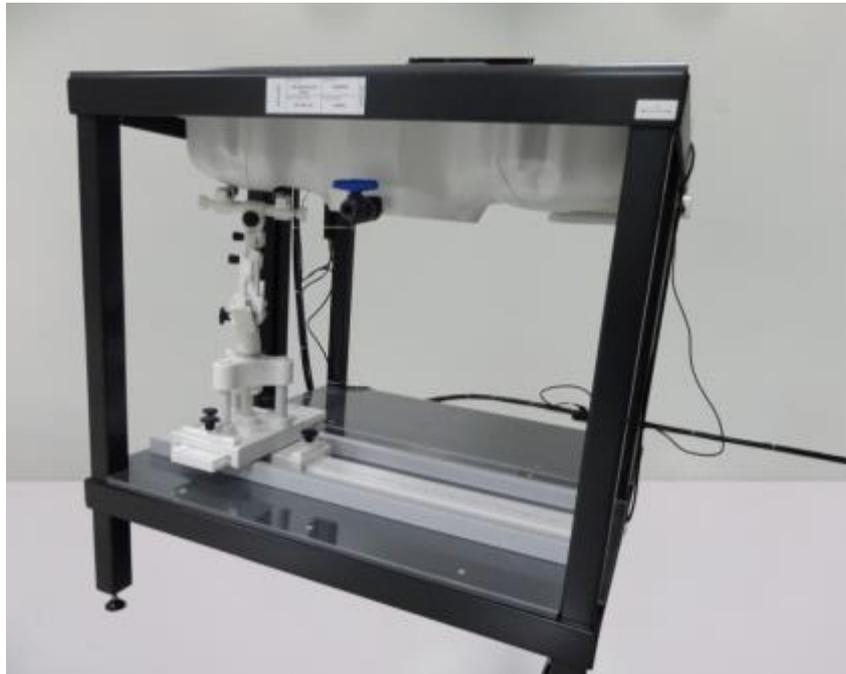

SAM Twin Phantom

### 3.4. Device Holder

In combination with the Generic Twin Phantom SAM117, the Mounting Device enables the rotation of the mounted transmitter in spherical coordinates whereby the rotation points is the ear opening. The devices can be easily, accurately, and repeatedly positioned according to the FCC and CENELEC specifications. The device holder can be locked at different phantom locations (left head, right head, flat phantom).



Device holder supplied by SATIMO

### 3.5. Scanning Procedure

The procedure for assessing the peak spatial-average SAR value consists of the following steps

#### Power Reference Measurement

The reference and drift jobs are useful jobs for monitoring the power drift of the device under test in the batch process. Both jobs measure the field at a specified reference position, at a selectable distance from the phantom surface. The reference position can be either the selected section's grid reference point or a user point in this section. The reference job projects the selected point onto the phantom surface, orients the probe perpendicularly to the surface, and approaches the surface using the selected detection method.

#### Area Scan

The Area Scan is used as a fast scan in two dimensions to find the area of high field values before running a detailed measurement around the hot spot. Before starting the area scan a grid spacing of 15 mm x 15 mm is set. During the scan the distance of the probe to the phantom remains unchanged. After finishing area scan, the field maxima within a range of 2 dB will be ascertained.

	≤ 3 GHz	> 3 GHz
Maximum distance from closest measurement point (geometric center of probe sensors) to phantom surface	5 mm ± 1 mm	$\frac{1}{2} \cdot \delta \cdot \ln(2)$ mm ± 0.5 mm
Maximum probe angle from probe axis to phantom surface normal at the measurement location	30° ± 1°	20° ± 1°
Maximum area scan spatial resolution: $\Delta x_{Area}$ , $\Delta y_{Area}$	≤ 2 GHz: ≤ 15 mm 2 – 3 GHz: ≤ 12 mm	3 – 4 GHz: ≤ 12 mm 4 – 6 GHz: ≤ 10 mm
	When the x or y dimension of the test device, in the measurement plane orientation, is smaller than the above, the measurement resolution must be ≤ the corresponding x or y dimension of the test device with at least one measurement point on the test device.	

#### Zoom Scan

Zoom Scans are used to estimate the peak spatial SAR values within a cubic averaging volume containing 1 g and 10 g of simulated tissue. The default Zoom Scan is done by 7x7x7 points within a cube whose base is centered around the maxima found in the preceding area scan.

Maximum zoom scan spatial resolution: $\Delta x_{Zoom}$ , $\Delta y_{Zoom}$		≤ 2 GHz: ≤ 8 mm 2 – 3 GHz: ≤ 5 mm*	3 – 4 GHz: ≤ 5 mm* 4 – 6 GHz: ≤ 4 mm*	
Maximum zoom scan spatial resolution, normal to phantom surface	uniform grid: $\Delta z_{Zoom}(n)$	≤ 5 mm	3 – 4 GHz: ≤ 4 mm 4 – 5 GHz: ≤ 3 mm 5 – 6 GHz: ≤ 2 mm	
	graded grid	$\Delta z_{Zoom}(1)$ : between 1 <sup>st</sup> two points closest to phantom surface	≤ 4 mm	3 – 4 GHz: ≤ 3 mm 4 – 5 GHz: ≤ 2.5 mm 5 – 6 GHz: ≤ 2 mm
		$\Delta z_{Zoom}(n>1)$ : between subsequent points	≤ 1.5 · $\Delta z_{Zoom}(n-1)$ mm	
Minimum zoom scan volume	x, y, z	≥ 30 mm	3 – 4 GHz: ≥ 28 mm 4 – 5 GHz: ≥ 25 mm 5 – 6 GHz: ≥ 22 mm	
Note: $\delta$ is the penetration depth of a plane-wave at normal incidence to the tissue medium; see IEEE Std 1528-2013 for details. * When zoom scan is required and the <i>reported</i> SAR from the <i>area scan based 1-g SAR estimation</i> procedures of KDB Publication 447498 is ≤ 1.4 W/kg, ≤ 8 mm, ≤ 7 mm and ≤ 5 mm zoom scan resolution may be applied, respectively, for 2 GHz to 3 GHz, 3 GHz to 4 GHz and 4 GHz to 6 GHz.				

### Power Drift measurement

The drift job measures the field at the same location as the most recent reference job within the same procedure, and with the same settings. The drift measurement gives the field difference in dB from the reading conducted within the last reference measurement. Several drift measurements are possible for one reference measurement. This allows a user to monitor the power drift of the device under test within a batch process. In the properties of the Drift job, the user can specify a limit for the drift and have OPENSAR software stop the measurements if this limit is exceeded.

## 3.6. Data Storage and Evaluation

### Data Storage

The OPENSAR software stores the acquired data from the data acquisition electronics as raw data (in microvolt readings from the probe sensors), together with all necessary software parameters for the data evaluation (probe calibration data, liquid parameters and device frequency and modulation data) in measurement files. The software evaluates the desired unit and format for output each time the data is visualized or exported. This allows verification of the complete software setup even after the measurement and allows correction of incorrect parameter settings. For example, if a measurement has been performed with a wrong crest factor parameter in the device setup, the parameter can be corrected afterwards and the data can be re-evaluated.

The measured data can be visualized or exported in different units or formats, depending on the selected probe type ([V/m], [A/m], [°C], [mW/g], [mW/cm<sup>2</sup>], [dBrel], etc.). Some of these units are not available in certain situations or show meaningless results, e.g., a SAR output in a lossless media will always be zero. Raw data can also be exported to perform the evaluation with other software packages.

### Data Evaluation

The OPENSAR software automatically executes the following procedures to calculate the field units from the microvolt readings at the probe connector. The parameters used in the evaluation are stored in the configuration modules of the software:

Probe parameters:	- Sensitivity	Normi, ai0, ai1, ai2
	- Conversion factor	ConvFi
	- Diode compression point	Dcpi
Device parameters:	- Frequency	f
	- Crest factor	cf
Media parameters:	- Conductivity	σ
	- Density	ρ

These parameters must be set correctly in the software. They can be found in the component documents or they can be imported into the software from the configuration files issued for the OPENSAR components. In the direct measuring mode of the multimeter option, the parameters of the actual system setup are used. In the scan visualization and export modes, the parameters stored in the corresponding document files are used.

The first step of the evaluation is a linearization of the filtered input signal to account for the compression characteristics of the detector diode. The compensation depends on the input signal, the diode type and the DC-transmission factor from the diode to the evaluation electronics. If the exciting field is pulsed, the crest factor of the signal must be known to correctly compensate for peak power. The formula for each channel can be given as:

$$V_i = U_i + U_i^2 \cdot \frac{cf}{dcp_i}$$

With  $V_i$  = compensated signal of channel  $i$  ( $i = x, y, z$ )

$U_i$  = input signal of channel  $i$  ( $i = x, y, z$ )

cf = crest factor of exciting field

dcp<sub>i</sub> = diode compression point

From the compensated input signals the primary field data for each channel can be evaluated:

$$E - \text{fieldprobes} : E_i = \sqrt{\frac{V_i}{Norm_i \cdot ConvF}}$$

$$H - \text{fieldprobes} : H_i = \sqrt{V_i} \cdot \frac{a_{i0} + a_{i1}f + a_{i2}f^2}{f}$$

With  $V_i$  = compensated signal of channel  $i$  ( $i = x, y, z$ )

$Norm_i$  = sensor sensitivity of channel  $i$  ( $i = x, y, z$ )  
[mV/(V/m)<sup>2</sup>] for E-field Probes

ConvF = sensitivity enhancement in solution

- aij = sensor sensitivity factors for H-field probes
- f = carrier frequency [GHz]
- Ei = electric field strength of channel i in V/m
- Hi = magnetic field strength of channel i in A/m

The RSS value of the field components gives the total field strength (Hermitian magnitude):

$$E_{tot} = \sqrt{E_x^2 + E_y^2 + E_z^2}$$

The primary field data are used to calculate the derived field units.

$$SAR = E_{tot}^2 \cdot \frac{\sigma}{\rho \cdot 1'000}$$

- with SAR = local specific absorption rate in mW/g
- Etot = total field strength in V/m
- σ = conductivity in [mho/m] or [Siemens/m]
- ρ = equivalent tissue density in g/cm3

Note that the density is normally set to 1 (or 1.06), to account for actual brain density rather than the density of the simulation liquid.

### 3.7. Position of the wireless device in relation to the phantom

#### General considerations

This standard specifies two handset test positions against the head phantom – the “cheek” position and the “tilt” position.

The power flow density is calculated assuming the excitation field as a free space field

$$P_{(pwe)} = \frac{E_{tot}^2}{3770} \text{ or } P_{(pwe)} = H_{tot}^2 \cdot 37.7$$

Where P<sub>pwe</sub>=Equivalent power density of a plane wave in mW/cm<sup>2</sup>

E<sub>tot</sub>=total electric field strength in V/m

H<sub>tot</sub>=total magnetic field strength in A/m

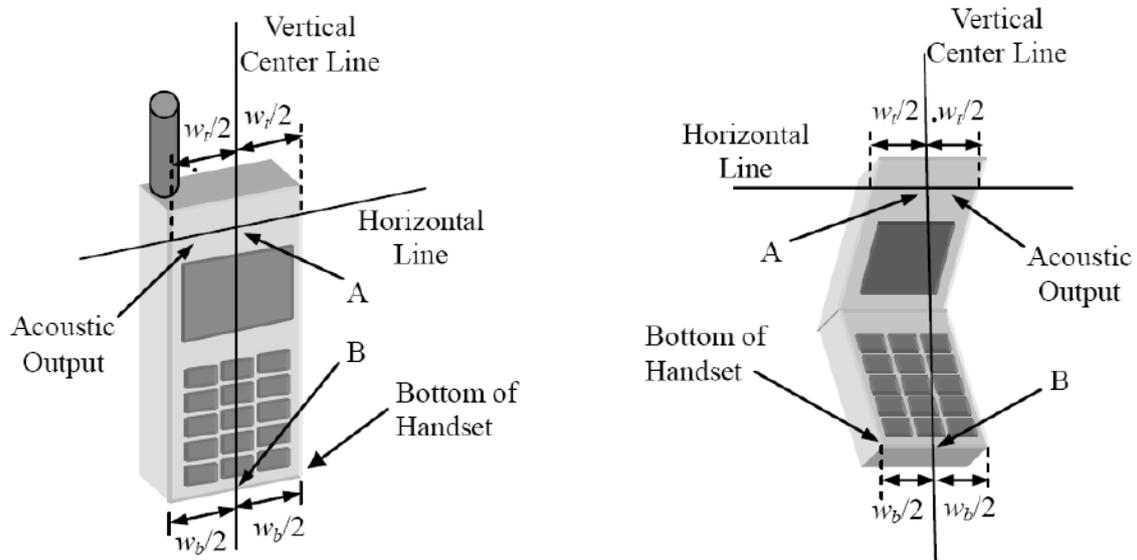

- W<sub>r</sub>Width of the handset at the level of the acoustic
- W<sub>b</sub>Width of the bottom of the handset
- A Midpoint of the width w<sub>r</sub> of the handset at the level of the acoustic output
- B Midpoint of the width w<sub>b</sub> of the bottom of the handset

Picture 1-a Typical “fixed” case handset    Picture 1-b Typical “clam-shell” case handset

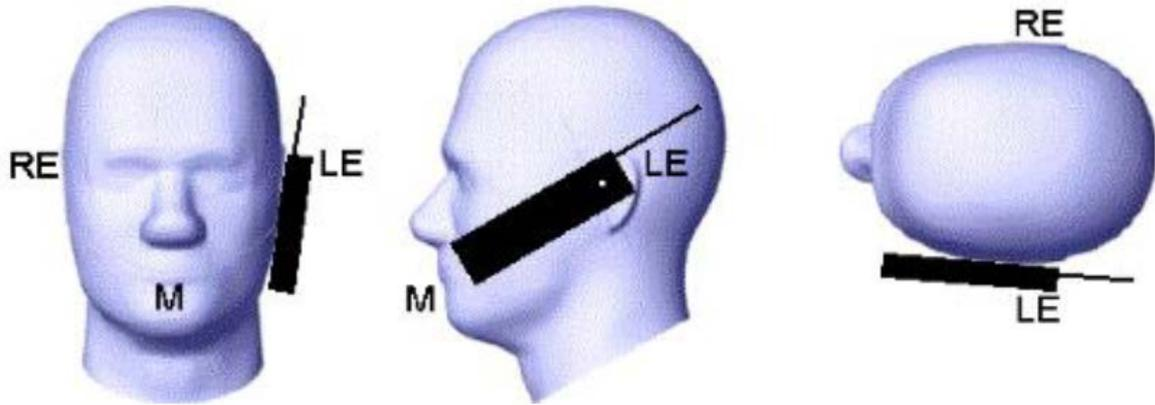

Picture 2 Cheek position of the wireless device on the left side of SAM

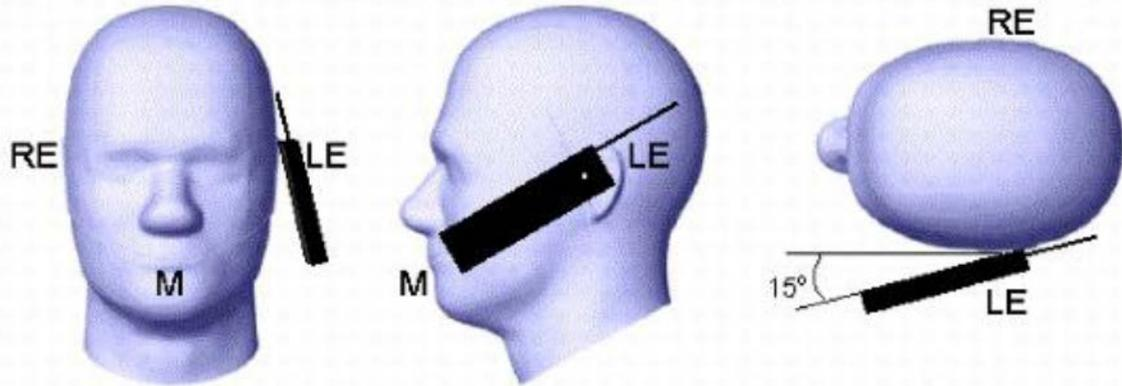

Picture 3 Tilt position of the wireless device on the left side of SAM

For body SAR test we applied to FCC KDB941225, KDB447498, KDB248227, KDB648654;



### 3.8. Tissue Dielectric Parameters for Head and Body Phantoms

The liquid is consisted of water,salt,Glycol,Sugar,Preventol and Cellulose.The liquid has previously been proven to be suited for worst-case.It's satisfying the latest tissue dielectric parameters requirements proposed by the KDB865664.

The composition of the tissue simulating liquid

Ingredient (% Weight)	750MHz		835MHz		1800 MHz		1900 MHz		2450MHz		2600MHz		5000MHz	
	Head	Body	Head	Body	Head	Body	Head	Body	Head	Body	Head	Body	Head	Body
Water	39.28	51.3	41.45	52.5	54.5	40.2	54.9	40.4	62.7	73.2	60.3	71.4	65.5	78.6
Preventol	0.10	0.10	0.10	0.10	0.00	0.00	0.00	0.00	0.00	0.00	0.00	0.00	0.00	0.00
HEC	1.00	1.00	1.00	1.00	0.00	0.00	0.00	0.00	0.00	0.00	0.00	0.00	0.00	0.00
DGBE	0.00	0.00	0.00	0.00	45.33	59.31	44.92	59.10	36.80	26.70	39.10	28.40	0.00	0.00
Triton X-100	0.00	0.00	0.00	0.00	0.00	0.00	0.00	0.00	0.00	0.00	0.00	0.00	17.2	10.7

Target Frequency (MHz)	Head		Body	
	$\epsilon_r$	$\sigma(S/m)$	$\epsilon_r$	$\sigma(S/m)$
150	52.3	0.76	61.9	0.80
300	45.3	0.87	58.2	0.92
450	43.5	0.87	56.7	0.94
835	41.5	0.90	55.2	0.97
900	41.5	0.97	55.0	1.05
915	41.5	0.98	55.0	1.06
1450	40.5	1.20	54.0	1.30
1610	40.3	1.29	53.8	1.40
1800-2000	40.0	1.40	53.3	1.52
2450	39.2	1.80	52.7	1.95
3000	38.5	2.40	52.0	2.73
5800	35.3	5.27	48.2	6.00

### 3.9. Tissue equivalent liquid properties

Dielectric Performance of Body Tissue Simulating Liquid

Tissue Type	Measured Frequency (MHz)	Target Tissue		Measured Tissue				Liquid Temp.	Test Data
		$\sigma$	$\epsilon_r$	$\sigma$	Dev.	$\epsilon_r$	Dev.		
835B	835	0.97	55.20	0.98	1.03%	55.25	0.09%	22.1	2017-11-11
1800B	1800	1.52	53.30	1.55	1.97%	53.37	0.13%	22.1	2017-11-13
1900B	1900	1.52	53.30	1.58	3.95%	53.11	-0.36%	22.1	2017-11-12

### 3.10. System Check

The purpose of the system check is to verify that the system operates within its specifications at the device test frequency. The system check is simple check of repeatability to make sure that the system works correctly at the time of the compliance test;

System check results have to be equal or near the values determined during dipole calibration with the relevant liquids and test system ( $\pm 10\%$ ).

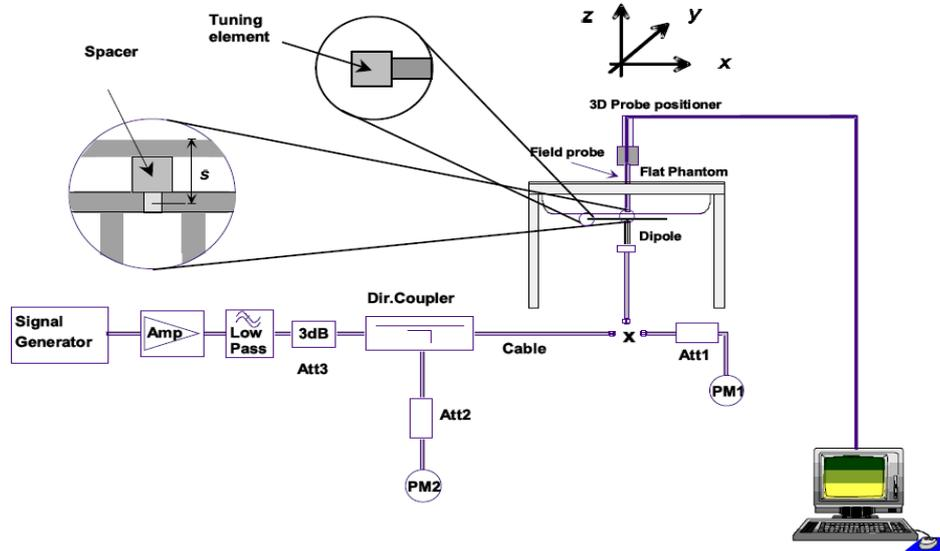

The output power on dipole port must be calibrated to 20 dBm (100mW) before dipole is connected.



Photo of Dipole Setup

**Justification for Extended SAR Dipole Calibrations**

Referring to KDB 865664D01V01r04, if dipoles are verified in return loss (<-20dB, within 20% of prior calibration), and in impedance (within 5 ohm of prior calibration), the annual calibration is not necessary and the calibration interval can be extended. While calibration intervals not exceed 3 years.

**SID835 SN 07/14 DIP 0G835-303 Extend Dipole Calibrations**

Date of Measurement	Return-Loss (dB)	Delta (%)	Real Impedance (ohm)	Delta (ohm)	Imaginary Impedance (ohm)	Delta (ohm)
2015-10-01	-24.46		55.4		2.4	
2016-09-30	-25.53	-4.374	56.1	0.7	1.352	-1.048
2017-09-28	-25.16	2.862	55.8	0.4	1.832	-0.568

**SID1800 SN 30/14 DIP 1G800-301 Extend Dipole Calibrations**

Date of Measurement	Return-Loss (dB)	Delta (%)	Real Impedance (ohm)	Delta (ohm)	Imaginary Impedance (ohm)	Delta (ohm)
2015-10-01	-20.19		43.4		7.2	
2016-09-30	-21.36	-5.795	44.5	1.1	6.9	-0.3
2017-09-28	-21.97	-8.816	45.3	1.9	6.1	-1.1

**SID1900 SN 30/14 DIP 1G900-333 Extend Dipole Calibrations**

Date of Measurement	Return-Loss (dB)	Delta (%)	Real Impedance (ohm)	Delta (ohm)	Imaginary Impedance (ohm)	Delta (ohm)
2015-10-01	-23.68		51.2		6.4	
2016-09-30	-24.19	-2.154	50.179	-1.021	3.521	-2.879
2017-09-28	-23.55	-0.549	50.395	-0.805	4.261	-2.139

Mixture Type	Frequency (MHz)	Power	SAR <sub>1g</sub> (W/Kg)	SAR <sub>10g</sub> (W/Kg)	Drift (%)	1W Target		Difference percentage		Liquid Temp	Date
						SAR <sub>1g</sub> (W/Kg)	SAR <sub>10g</sub> (W/Kg)	1g	10g		
Body	835	100 mW	0.952	0.625	-0.20	9.90	6.39	-3.84%	-2.19%	22.1	10/11/2017
		Normalize to 1 Watt	9.52	6.25							
Body	1800	100 mW	4.018	2.094	-0.60	39.03	20.65	2.95%	1.40%	22.1	10/13/2017
		Normalize to 1 Watt	40.18	20.94							
Body	1900	100 mW	4.291	2.132	-2.33	43.33	21.59	-0.09%	-1.25%	22.1	10/12/2017
		Normalize to 1 Watt	43.29	21.32							

**3.11. SAR measurement procedure**

The measurement procedures are as follows:

**3.11.1 Conducted power measurement**

- For WWAN power measurement, use base station simulator connection with RF cable, at maximum power in each supported wireless interface and frequency band.
- Read the WWAN RF power level from the base station simulator.

**3.11.2 GSM Test Configuration**

SAR tests for GSM 850 and GSM 1900, a communication link is set up with a System Simulator (SS) by air link. Using CMU200 the power level is set to "5" for GSM 850, set to "0" for GSM 1900. Since the GPRS class is 12 for this EUT, it has at most 4 timeslots in uplink and at most 4 timeslots in downlink, the maximum total timeslots is 5. the EGPRS class is 12 for this EUT, it has at most 4 timeslots in uplink and at most 4 timeslots in downlink, the maximum total timeslots is 5.

SAR test reduction for GPRS and EDGE modes is determined by the source-based time-averaged output power specified for production units, including tune-up tolerance. The data mode with highest specified time-averaged output power should be tested for SAR compliance in the applicable exposure conditions. For modes with the same specified maximum output power and tolerance, the higher number time-slot configuration should be tested. GSM voice and GPRS data use GMSK, which is a constant amplitude modulation with minimal peak to average power difference within the time-slot burst. For EDGE, GMSK is used for MCS 1 – MCS 4 and 8-PSK is used for

MCS 5 – MCS 9; where 8-PSK has an inherently higher peak-to-average power ratio. The GMSK and 8-PSK EDGE configurations are considered separately for SAR compliance. The GMSK EDGE configurations are grouped with GPRS and considered with respect to time-averaged maximum output power to determine compliance. The 3G SAR test reduction procedure is applied to 8-PSK EDGE with GMSK GPRS/EDGE as the primary mode.

### 3.11.3 UMTS Test Configuration

#### 3G SAR Test Reduction Procedure

In the following procedures, the mode tested for SAR is referred to as the primary mode. The equivalent modes considered for SAR test reduction are denoted as secondary modes. Both primary and secondary modes must be in the same frequency band. When the maximum output power and tune-up tolerance specified for production units in a secondary mode is  $\leq \frac{1}{4}$  dB higher than the primary mode or when the highest reported SAR of the primary mode is scaled by the ratio of specified maximum output power and tune-up tolerance of secondary to primary mode and the adjusted SAR is  $\leq 1.2$  W/kg, SAR measurement is not required for the secondary mode.<sup>3</sup> This is referred to as the 3G SAR test reduction procedure in the following SAR test guidance, where the primary mode is identified in the applicable wireless mode test procedures and the secondary mode is wireless mode being considered for SAR test reduction by that procedure. When the 3G SAR test reduction procedure is not satisfied, it is identified as “otherwise” in the applicable procedures; SAR measurement is required for the secondary mode.

#### Output power Verification

Maximum output power is verified on the high, middle and low channels according to procedures described in section 5.2 of 3GPP TS 34.121, using the appropriate RMC or AMR with TPC (transmit power control) set to all “1’s” for WCDMA/HSDPA or by applying the required inner loop power control procedures to maintain maximum output power while HSUPA is active. Results for all applicable physical channel configurations (DPCCH, DPDCHn and spreading codes, HSDPA, HSPA) are required in the SAR report. All configurations that are not supported by the handset or cannot be measured due to technical or equipment limitations must be clearly identified.

#### Head SAR

SAR for next to the ear head exposure is measured using a 12.2 kbps RMC with TPC bits configured to all “1’s”. The 3G SAR test reduction procedure is applied to AMR configurations with 12.2 kbps RMC as the primary mode. Otherwise, SAR is measured for 12.2 kbps AMR in 3.4 kbps SRB (signaling radio bearer) using the highest reported SAR configuration in 12.2 kbps RMC for head exposure.

#### 1) Body-Worn Accessory SAR

SAR for body-worn accessory configurations is measured using a 12.2 kbps RMC with TPC bits configured to all “1’s”. The 3G SAR test reduction procedure is applied to other spreading codes and multiple DPDCHn configurations supported by the handset with 12.2 kbps RMC as the primary mode. Otherwise, SAR is measured using an applicable RMC configuration with the corresponding spreading code or DPDCHn, for the highest reported body-worn accessory exposure SAR configuration in 12.2 kbps RMC. When more than 2 DPDCHn are supported by the handset, it may be necessary to configure additional DPDCHn using FTM (Factory Test Mode) or other chipset based test approaches with parameters similar to those used in 384 kbps and 768 kbps RMC.

#### 2) Handsets with Release 5 HSDPA

The 3G SAR test reduction procedure is applied to HSDPA body-worn accessory configurations with 12.2 kbps RMC as the primary mode. Otherwise, SAR is measured for HSDPA using the HSDPA body SAR procedures in the “Release 5 HSDPA Data Devices” section of this document, for the highest reported SAR body-worn accessory exposure configuration in 12.2 kbps RMC. Handsets with both HSDPA and HSUPA are tested according to Release 6 HSPA test procedures.

HSDPA should be configured according to the UE category of a test device. The number of HSDSCH/ HS-PDSCHs, HARQ processes, minimum inter-TTI interval, transport block sizes and RV coding sequence are defined by the H-set. To maintain a consistent test configuration and stable transmission conditions, QPSK is used in the H-set for SAR testing. HS-DPCCH should be configured with a CQI feedback cycle of 4 ms with a CQI repetition factor of 2 to maintain a constant rate of active CQI slots. DPCCH and DPDCH gain factors ( $\beta_c$ ,  $\beta_d$ ), and HS-DPCCH power offset parameters ( $\Delta_{ACK}$ ,  $\Delta_{NACK}$ ,  $\Delta_{CQI}$ ) should be set according to values indicated in the Table below. The CQI value is determined by the UE category, transport block size, number of HS-PDSCHs and modulation used in the H-set

**Table 2: Subtests for UMTS Release 5 HSDPA**

Sub-set	$\beta_c$	$\beta_d$	$\beta_d$ (SF)	$\beta_c/\beta_d$	$\beta_{hs}$ (note 1, note 2)	CM(dB) (note 3)	MPR(dB)
1	2/15	15/15	64	2/15	4/15	0.0	0.0
2	12/15 (note 4)	15/15 (note 4)	64	12/15 (note 4)	24/15	1.0	0.0
3	15/15	8/15	64	15/8	30/15	1.5	0.5
4	15/15	4/15	64	15/4	30/15	1.5	0.5

Note1:  $\Delta_{ACK}$ ,  $\Delta_{NACK}$  and  $\Delta_{CQI} = 8 \Leftrightarrow A_{hs} = \beta_{hs}/\beta_c = 30/15 \Leftrightarrow \beta_{hs} = 30/15 * \beta_c$

Note2: CM=1 for  $\beta_c/\beta_d = 12/15$ ,  $\beta_{hs}/\beta_c = 24/15$ .

Note3: For subtest 2 the  $\beta_c/\beta_d$  ratio of 12/15 for the TFC during the measurement period(TF1,TF0) is achieved by setting the signaled gain factors for the reference TFC (TFC1,TF1) to  $\beta_c=11/15$  and  $\beta_d=15/15$ .

### HSUPA Test Configuration

The 3G SAR test reduction procedure is applied to HSPA (HSUPA/HSDPA with RMC) body-worn accessory configurations with 12.2 kbps RMC as the primary mode. Otherwise, SAR is measured for HSPA using the HSPA body SAR procedures in the "Release 6 HSPA Data Devices" section of this document, for the highest reported body-worn accessory exposure SAR configuration in 12.2 kbps RMC. When VOIP is applicable for next to the ear head exposure in HSPA, the 3G SAR test reduction procedure is applied to HSPA with 12.2 kbps RMC as the primary mode; otherwise, the same HSPA configuration used for body-worn accessory measurements is tested for next to the ear head exposure.

Due to inner loop power control requirements in HSPA, a communication test set is required for output power and SAR tests. The 12.2 kbps RMC, FRC H-set 1 and E-DCH configurations for HSPA are configured according to the  $\beta$  values indicated in Table 2 and other applicable procedures described in the 'WCDMA Handset' and 'Release 5 HSDPA Data Devices' sections of this document

**Table 3: Sub-Test 5 Setup for Release 6 HSUPA**

Sub-set	$\beta_c$	$\beta_d$	$\beta_d$ (SF)	$\beta_c/\beta_d$	$\beta_{hs}^{(1)}$	$\beta_{ec}$	$\beta_{ed}$	$\beta_{ed}$ (SF)	$\beta_{ed}$ (codes)	CM <sup>(2)</sup> (dB)	MPR (dB)	AG <sup>(4)</sup> Index	E-TFCI
1	11/15 <sup>(3)</sup>	15/15 <sup>(3)</sup>	64	11/15 <sup>(3)</sup>	22/15	209/225	1039/225	4	1	1.0	0.0	20	75
2	6/15	15/15	64	6/15	12/15	12/15	94/75	4	1	3.0	2.0	12	67
3	15/15	9/15	64	15/9	30/15	30/15	$\beta_{ed1}: 47/15$ $\beta_{ed2}: 47/15$	4	2	2.0	1.0	15	92
4	2/15	15/15	64	2/15	4/15	2/15	56/75	4	1	3.0	2.0	17	71
5	15/15 <sup>(4)</sup>	15/15 <sup>(4)</sup>	64	15/15 <sup>(4)</sup>	30/15	24/15	134/15	4	1	1.0	0.0	21	81

Note 1:  $\Delta_{ACK}$ ,  $\Delta_{NACK}$  and  $\Delta_{CQI} = 8 \Leftrightarrow A_{hs} = \beta_{hs}/\beta_c = 30/15 \Leftrightarrow \beta_{hs} = 30/15 * \beta_c$ .

Note 2: CM = 1 for  $\beta_c/\beta_d = 12/15$ ,  $\beta_{hs}/\beta_c = 24/15$ . For all other combinations of DPDCH, DPCCH, HS-DPCCH, E-DPDCH and E-DPCCH the MPR is based on the relative CM difference.

Note 3: For subtest 1 the  $\beta_c/\beta_d$  ratio of 11/15 for the TFC during the measurement period (TF1, TF0) is achieved by setting the signaled gain factors for the reference TFC (TF1, TF1) to  $\beta_c = 10/15$  and  $\beta_d = 15/15$ .

Note 4: For subtest 5 the  $\beta_c/\beta_d$  ratio of 15/15 for the TFC during the measurement period (TF1, TF0) is achieved by setting the signaled gain factors for the reference TFC (TF1, TF1) to  $\beta_c = 14/15$  and  $\beta_d = 15/15$ .

Note 5: Testing UE using E-DPDCH Physical Layer category 1 Sub-test 3 is not required according to TS 25.306 Figure 5.1g.

Note 6:  $\beta_{ed}$  can not be set directly; it is set by Absolute Grant Value.

### 3.11.4 LTE Test Configuration

#### QPSK with 1 RB allocation

Start with the largest channel bandwidth and measure SAR for QPSK with 1 RB allocation, using the RB offset and required test channel combination with the highest maximum output power among RB offsets at the upper edge, middle and lower edge of each required test channel. When the reported SAR is  $\leq 0.8$  W/kg, testing of the remaining RB offset configurations and required test channels is not required for 1 RB allocation; otherwise, SAR is required for the remaining required test channels and only for the RB offset configuration with the highest output power for that channel.8 When the reported SAR of a required test channel is  $> 1.45$  W/kg, SAR is required for all three RB offset configurations for that required test channel.

#### QPSK with 50% RB allocation

The procedures required for 1 RB allocation in section 4.2.1 are applied to measure the SAR for QPSK with 50% RB allocation.9

#### QPSK with 100% RB allocation

For QPSK with 100% RB allocation, SAR is not required when the highest maximum output power for 100 % RB allocation is less than the highest maximum output power in 50% and 1 RB allocations and the highest reported SAR for 1 RB and 50% RB allocation in sections 4.2.1 and 4.2.2 are  $\leq 0.8$  W/kg. Otherwise, SAR is measured for the highest output power channel; and if the reported SAR is  $> 1.45$  W/kg, the remaining required test channels must also be tested.

### 3.12. Power Reduction

The product without any power reduction.

### 3.13. Power Drift

To control the output power stability during the SAR test, SAR system calculates the power drift by measuring the E-field at the same location at the beginning and at the end of the measurement for each test position. This ensures that the power drift during one measurement is within 5%.

## 4. TEST CONDITIONS AND RESULTS

### 4.1. Conducted Power Results

According KDB 447498 D01 General RF Exposure Guidance v06 Section 4.1 2) states that "Unless it is specified differently in the published RF exposure KDB procedures, these requirements also apply to test reduction and test exclusion considerations. Time-averaged maximum conducted output power applies to SAR and, as required by § 2.1091(c), time-averaged ERP applies to MPE. When an antenna port is not available on the device to support conducted power measurement, such as FRS and certain Part 15 transmitters with built-in integral antennas, the maximum output power allowed for production units should be used to determine RF exposure test exclusion and compliance."

#### <GSM Conducted Power>

General Note:

1. Per KDB 447498 D01v06, the maximum output power channel is used for SAR testing and for further SAR test reduction.
2. According to October 2013TCB Workshop, for GSM / GPRS / EGPRS, the number of time slots to test for SAR should correspond to the highest frame-average maximum output power configuration, considering the possibility of e.g. 3rd party VoIP operation for head and body-worn SAR testing.
3. For hotspot mode SAR testing, GPRS / EDGE should be evaluated.

#### Conducted power measurement results for GSM850/PCS1900

GSM 850		Burst Conducted power (dBm)			/	Average power (dBm)		
		Channel/Frequency(MHz)				Channel/Frequency(MHz)		
		128/824.2	190/836.6	251/848.8		128/824.2	190/836.6	251/848.8
GPRS (GMSK)	1TX slot	32.44	32.29	32.20	-9.03dB	23.41	23.26	23.17
	2TX slot	30.84	30.99	30.88	-6.02dB	24.82	24.97	24.86
	<b>3TX slot</b>	<b>29.26</b>	<b>29.58</b>	<b>29.57</b>	<b>-4.26dB</b>	<b>25.00</b>	<b>25.32</b>	<b>25.31</b>
	4TX slot	27.65	27.39	27.28	-3.01dB	24.64	24.38	24.27
EGPRS (8PSK)	1TX slot	25.17	25.62	25.20	-9.03dB	16.14	16.59	16.17
	2TX slot	24.55	24.58	24.78	-6.02dB	18.53	18.56	18.76
	3TX slot	23.36	23.69	23.81	-4.26dB	19.10	19.43	19.55
	4TX slot	22.56	22.59	22.55	-3.01dB	19.55	19.58	19.54
GSM 1900		Burst Conducted power (dBm)			/	Average power (dBm)		
		Channel/Frequency(MHz)				Channel/Frequency(MHz)		
		512/ 1850.2	661/ 1880	810/ 1909.8		512/ 1850.2	661/ 1880	810/ 1909.8
GPRS (GMSK)	1TX slot	30.86	30.42	30.49	-9.03dB	21.83	21.39	21.46
	2TX slot	29.59	29.27	29.34	-6.02dB	23.57	23.25	23.32
	3TX slot	28.64	28.14	28.13	-4.26dB	24.38	23.88	23.87
	<b>4TX slot</b>	<b>27.75</b>	<b>27.55</b>	<b>27.29</b>	<b>-3.01dB</b>	<b>24.74</b>	<b>24.54</b>	<b>24.28</b>
EGPRS (8PSK)	1TX slot	25.75	25.64	25.16	-9.03dB	16.72	16.61	16.13
	2TX slot	24.72	24.56	24.87	-6.02dB	18.70	18.54	18.85
	3TX slot	23.64	23.31	23.79	-4.26dB	19.38	19.05	19.53
	4TX slot	22.55	22.34	22.52	-3.01dB	19.54	19.33	19.51

#### Notes:

##### 1. Division Factors

To average the power, the division factor is as follows:

1TX-slot = 1 transmit time slot out of 8 time slots=> conducted power divided by (8/1) => -9.00dB

2TX-slots = 2 transmit time slots out of 8 time slots=> conducted power divided by (8/2) => -6.00dB

3TX-slots = 3 transmit time slots out of 8 time slots=> conducted power divided by (8/3) => -4.26dB

4TX-slots = 4 transmit time slots out of 8 time slots=> conducted power divided by (8/4) => -3.00dB

2. According to the conducted power as above, the GPRS measurements are performed with 3Txslot for GPRS850 and 4Txslot GPRS1900.

**<UMTS Conducted Power>**

The following tests were conducted according to the test requirements outlines in 3GPP TS 34.121 specification. A summary of these settings are illustrated below:

**HSDPA Setup Configuration:**

- a. The EUT was connected to Base Station E5515C referred to the Setup Configuration.
- b. The RF path losses were compensated into the measurements.
- c. A call was established between EUT and Base Station with following setting:
  - i. Set Gain Factors ( $\beta_c$  and  $\beta_d$ ) and parameters were set according to each
  - ii. Specific sub-test in the following table, C10.1.4, quoted from the TS 34.121
  - iii. Set RMC 12.2Kbps + HSDPA mode.
  - iv. Set Cell Power = -86 dBm
  - v. Set HS-DSCH Configuration Type to FRC (H-set 1, QPSK)
  - vi. Select HSDPA Uplink Parameters
  - vii. Set Delta ACK, Delta NACK and Delta CQI = 8
  - viii. Set Ack-Nack Repetition Factor to 3
  - ix. Set CQI Feedback Cycle (k) to 4 ms
  - x. Set CQI Repetition Factor to 2
  - xi. Power Ctrl Mode = All Up bits
- d. The transmitted maximum output power was recorded.

**Table C.10.1.4:  $\beta$  values for transmitter characteristics tests with HS-DPCCH**

Sub-test	$\beta_c$	$\beta_d$	$\beta_d$ (SF)	$\beta_c/\beta_d$	$\beta_{HS}$ (Note 1, Note 2)	CM (dB) (Note 3)	MPR (dB) (Note 3)
1	2/15	15/15	64	2/15	4/15	0.0	0.0
2	12/15 (Note 4)	15/15 (Note 4)	64	12/15 (Note 4)	24/15	1.0	0.0
3	15/15	8/15	64	15/8	30/15	1.5	0.5
4	15/15	4/15	64	15/4	30/15	1.5	0.5

Note 1:  $\Delta_{ACK}$ ,  $\Delta_{NACK}$  and  $\Delta_{CQI} = 30/15$  with  $\beta_{HS} = 30/15 * \beta_c$ .

Note 2: For the HS-DPCCH power mask requirement test in clause 5.2C, 5.7A, and the Error Vector Magnitude (EVM) with HS-DPCCH test in clause 5.13.1A, and HSDPA EVM with phase discontinuity in clause 5.13.1AA,  $\Delta_{ACK}$  and  $\Delta_{NACK} = 30/15$  with  $\beta_{HS} = 30/15 * \beta_c$ , and  $\Delta_{CQI} = 24/15$  with  $\beta_{HS} = 24/15 * \beta_c$ .

Note 3: CM = 1 for  $\beta_c/\beta_d = 12/15$ ,  $\beta_{HS}/\beta_c = 24/15$ . For all other combinations of DPDCCH, DPCCH and HS-DPCCH the MPR is based on the relative CM difference. This is applicable for only UEs that support HSDPA in release 6 and later releases.

Note 4: For subtest 2 the  $\beta_c/\beta_d$  ratio of 12/15 for the TFC during the measurement period (TF1, TF0) is achieved by setting the signalled gain factors for the reference TFC (TF1, TF1) to  $\beta_c = 11/15$  and  $\beta_d = 15/15$ .

**Setup Configuration****HSUPA Setup Configuration:**

- a. The EUT was connected to Base Station R&S CMU200 referred to the Setup Configuration.
- b. The RF path losses were compensated into the measurements.
- c. A call was established between EUT and Base Station with following setting \* :
  - i. Call Configs = 5.2B, 5.9B, 5.10B, and 5.13.2B with QPSK
  - ii. Set the Gain Factors ( $\beta_c$  and  $\beta_d$ ) and parameters (AG Index) were set according to each specific sub-test in the following table, C11.1.3, quoted from the TS 34.121
  - iii. Set Cell Power = -86 dBm
  - iv. Set Channel Type = 12.2k + HSPA
  - v. Set UE Target Power
  - vi. Power Ctrl Mode= Alternating bits
  - vii. Set and observe the E-TFCI
  - viii. Confirm that E-TFCI is equal to the target E-TFCI of 75 for sub-test 1, and other subtest's E-TFCI
- d. The transmitted maximum output power was recorded.



Table C.11.1.3:  $\beta$  values for transmitter characteristics tests with HS-DPCCH and E-DCH

Sub-test	$\beta_c$	$\beta_d$	$\beta_d$ (SF)	$\beta_c/\beta_d$	$\beta_{HS}$ (Note 1)	$\beta_{ec}$	$\beta_{ed}$ (Note 5) (Note 6)	$\beta_{ed}$ (SF)	$\beta_{ed}$ (Codes)	CM (dB) (Note 2)	MPR (dB) (Note 2)	AG Index (Note 6)	E-TFCI
1	11/15 (Note 3)	15/15 (Note 3)	64	11/15 (Note 3)	22/15	209/25	1309/225	4	1	1.0	0.0	20	75
2	6/15	15/15	64	6/15	12/15	12/15	94/75	4	1	3.0	2.0	12	67
3	15/15	9/15	64	15/9	30/15	30/15	$\beta_{ed1}$ : 47/15 $\beta_{ed2}$ : 47/15	4 4	2	2.0	1.0	15	92
4	2/15	15/15	64	2/15	4/15	2/15	56/75	4	1	3.0	2.0	17	71
5	15/15 (Note 4)	15/15 (Note 4)	64	15/15 (Note 4)	30/15	24/15	134/15	4	1	1.0	0.0	21	81

Note 1:  $\Delta_{ACK}$ ,  $\Delta_{NACK}$  and  $\Delta_{CQI} = 30/15$  with  $\beta_{hs} = 30/15 * \beta_c$ .

Note 2: CM = 1 for  $\beta_c/\beta_d = 12/15$ ,  $\beta_{hs}/\beta_c = 24/15$ . For all other combinations of DPDCH, DPCCH, HS-DPCCH, E-DPDCH and E-DPCCH the MPR is based on the relative CM difference.

Note 3: For subtest 1 the  $\beta_c/\beta_d$  ratio of 11/15 for the TFC during the measurement period (TF1, TF0) is achieved by setting the signalled gain factors for the reference TFC (TF1, TF1) to  $\beta_c = 10/15$  and  $\beta_d = 15/15$ .

Note 4: For subtest 5 the  $\beta_c/\beta_d$  ratio of 15/15 for the TFC during the measurement period (TF1, TF0) is achieved by setting the signalled gain factors for the reference TFC (TF1, TF1) to  $\beta_c = 14/15$  and  $\beta_d = 15/15$ .

Note 5: In case of testing by UE using E-DPDCH Physical Layer category 1, Sub-test 3 is omitted according to TS25.306 Table 5.1g.

Note 6:  $\beta_{ed}$  can not be set directly, it is set by Absolute Grant Value.

### General Note

1. Per KDB 941225 D01, RMC 12.2kbps setting is used to evaluate SAR. If AMR 12.2kbps power is < 0.25dB higher than RMC 12.2kbps, SAR tests with AMR 12.2kbps can be excluded.
2. By design, AMR and HSDPA/HSUPA RF power will not be larger than RMC 12.2kbps, detailed information is included in Tune-up Procure exhibit.
3. It is expected by the manufacturer that MPR for some HSDPA/HSUPA subtests may differ from the specification of 3GPP, according to the chipset implementation in this model. The implementation and expected deviation are detailed in tune-up procedure exhibit.

### Conducted Power Measurement Results(WCDMA Band II/V)

Item	Band	FDD Band V result (dBm)			FDD Band II result (dBm)		
		Test Channel			Test Channel		
		4132/826.4	4183/836.6	4233/846.6	9262/1852.4	9400/1880	9538/1907.6
RMC	12.2kbps	23.88	23.75	24.22	23.74	23.47	24.05
	64kbps	23.61	23.57	24.01	23.42	23.29	23.66
	144kbps	23.55	23.46	23.76	23.32	23.10	23.34
	384kbps	23.34	23.29	23.57	23.16	23.01	23.29
HSDPA	Subtest 1	22.86	22.39	22.85	22.62	22.74	22.22
	Subtest 2	22.52	22.83	22.08	22.82	22.62	22.27
	Subtest 3	22.68	22.66	22.06	22.74	22.65	22.89
	Subtest 4	22.84	22.68	22.33	22.73	22.41	22.05
HSUPA	Subtest 1	22.67	22.41	22.43	22.42	22.08	22.01
	Subtest 2	22.56	22.55	22.62	22.58	22.36	22.73
	Subtest 3	22.34	22.43	22.68	22.57	22.09	22.76
	Subtest 4	22.52	22.68	22.58	22.72	22.12	22.03
	Subtest 5	22.36	22.49	22.82	22.44	22.13	22.86

**Note:** When the maximum output power and tune-up tolerance specified for production units in a secondary mode is  $\leq 1/2$ dB higher than the primary mode (RMC12.2kbps) or when the highest reported SAR of the primary mode is scaled by the ratio of specified maximum output power and tune-up tolerance of secondary to primary mode and the adjusted SAR is  $\leq 1.2$  W/kg, SAR measurement is not required for the secondary mode.

## LTE Band2

BW (MHz)	Frequency (MHz)	RB Configuration		Average Power [dBm]	
		Size	Offset	QPSK	16QAM
1.4	1850.7	1	0	23.40	22.79
		1	3	23.55	22.96
		1	5	23.44	22.81
		3	0	23.62	22.81
		3	2	23.62	22.75
		3	3	23.63	22.78
		6	0	22.50	21.58
	1880.0	1	0	23.58	22.84
		1	3	23.66	22.74
		1	5	23.61	22.44
		3	0	23.71	22.73
		3	2	23.64	22.70
		3	3	23.72	22.79
		6	0	22.64	21.67
	1909.3	1	0	23.82	22.99
		1	3	23.81	22.52
		1	5	23.87	22.77
		3	0	23.93	22.92
		3	2	23.89	22.88
		3	3	23.91	22.92
		6	0	22.85	21.95
3	1851.5	1	0	23.52	22.85
		1	7	23.57	22.90
		1	14	23.49	22.83
		8	0	22.59	21.73
		8	4	22.58	21.75
		8	7	22.58	21.72
		15	0	22.62	21.68
	1880.0	1	0	23.55	22.89
		1	7	23.56	22.89
		1	14	23.52	22.85
		8	0	22.66	21.76
		8	4	22.68	21.78
		8	7	22.64	21.72
		15	0	22.67	21.68
	1908.5	1	0	23.76	22.88
		1	7	23.84	22.71
		1	14	23.80	22.96
		8	0	22.86	21.85
		8	4	22.84	21.81
		8	7	22.86	21.85
		15	0	22.82	21.86
5	1852.5	1	0	23.61	22.77
		1	12	23.66	22.91
		1	24	23.55	22.70
		12	0	22.70	21.95
		12	6	22.70	21.96
		12	13	22.69	21.94
		25	0	22.64	21.79
	1880.0	1	0	23.67	22.91
		1	12	23.69	22.88
		1	24	23.62	22.95
		12	0	22.77	21.96
		12	6	22.76	21.95
		12	13	22.73	21.97
		25	0	22.71	21.80
	1907.5	1	0	23.86	22.85
		1	12	23.89	22.87

		1	24	23.93	22.77
		12	0	22.86	21.96
		12	6	22.86	21.96
		12	13	22.90	21.97
		25	0	22.84	21.93
10	1855.0	1	0	23.59	22.92
		1	24	23.62	22.95
		1	49	23.50	22.87
		25	0	22.69	21.77
		25	12	22.64	21.89
		25	25	22.63	21.75
		50	0	22.81	21.77
	1880.0	1	0	23.66	22.88
		1	24	23.66	22.96
		1	49	23.63	22.95
		25	0	22.75	21.82
		25	12	22.73	21.80
		25	25	22.68	21.77
		50	0	22.75	21.80
	1905.0	1	0	23.77	22.94
		1	24	23.82	22.87
		1	49	23.82	22.91
		25	0	22.95	21.98
		25	12	22.94	21.91
		25	25	22.95	21.89
		50	0	22.83	21.92
15	1857.5	1	0	23.61	22.88
		1	37	23.65	22.98
		1	74	23.88	22.95
		37	0	22.67	21.85
		37	18	22.69	22.16
		37	38	22.62	22.08
		75	0	22.51	22.28
	1880.0	1	0	23.89	22.88
		1	37	23.63	22.95
		1	74	23.10	22.78
		37	0	23.10	21.78
		37	18	22.73	21.75
		37	38	23.18	21.75
		75	0	22.75	21.78
	1902.5	1	0	23.67	22.80
		1	37	23.79	22.81
		1	74	23.87	22.78
		37	0	22.81	21.86
		37	18	22.60	21.82
		37	38	22.89	21.84
		75	0	22.65	21.88
20	1860.0	1	0	23.73	22.93
		1	49	23.68	22.96
		1	99	23.71	22.95
		50	0	22.72	21.80
		50	25	22.70	21.77
		50	50	22.69	21.75
		100	0	22.72	21.79
	1880.0	1	0	23.77	22.95
		1	49	23.77	22.99
		1	99	23.73	22.81
		50	0	22.58	21.30
		50	25	22.32	21.19
		50	50	22.85	21.17
		100	0	22.16	21.06

	1900.0	1	0	23.82	22.84
		1	49	23.88	22.95
		1	99	23.74	22.83
		50	0	22.77	21.67
		50	25	22.82	21.83
		50	50	22.82	21.69
		100	0	22.73	21.79

## LTE Band4

BW (MHz)	Frequency (MHz)	RB Configuration		Average Power [dBm]	
		Size	Offset	QPSK	16QAM
1.4	1710.7	1	0	23.82	22.76
		1	3	23.80	22.90
		1	5	23.81	22.95
		3	0	23.79	22.91
		3	2	23.76	22.85
		3	3	23.77	22.86
		6	0	23.40	22.74
	1732.5	1	0	23.64	22.97
		1	3	23.62	22.80
		1	5	23.67	22.97
		3	0	23.70	22.68
		3	2	23.62	22.64
		3	3	23.66	22.67
		6	0	23.63	22.57
	1754.3	1	0	23.53	22.75
		1	3	23.54	22.81
		1	5	23.53	22.76
		3	0	23.59	22.62
		3	2	23.54	22.56
		3	3	23.54	22.60
		6	0	23.17	22.47
3	1711.5	1	0	23.69	22.93
		1	7	23.73	22.96
		1	14	23.65	22.90
		8	0	22.80	21.85
		8	4	22.81	21.87
		8	7	22.79	21.83
		15	0	22.78	21.79
	1732.5	1	0	23.53	22.79
		1	7	23.58	22.88
		1	14	23.53	22.80
		8	0	22.65	21.72
		8	4	22.65	21.73
		8	7	22.66	21.71
		15	0	22.63	21.65
	1753.5	1	0	23.52	22.85
		1	7	23.56	22.88
		1	14	23.45	22.77
		8	0	22.60	21.57
		8	4	22.58	21.53
		8	7	22.55	21.56
		15	0	22.51	21.55
5	1712.0	1	0	23.78	22.81
		1	12	23.77	22.90
		1	24	23.69	22.80
		12	0	22.84	21.98
		12	6	22.81	21.96
		12	13	22.80	21.93
		25	0	22.75	21.78
	1732.5	1	0	23.64	22.91
		1	12	23.66	22.72
		1	24	23.59	22.93
		12	0	22.71	21.86
		12	6	22.68	21.86
		12	13	22.70	21.87
		25	0	22.64	21.70
	1752.5	1	0	23.64	22.65
		1	12	23.63	22.66

		1	24	23.55	22.51
		12	0	22.64	21.71
		12	6	22.61	21.67
		12	13	22.58	21.65
		25	0	22.57	21.65
10	1715.0	1	0	23.79	22.85
		1	24	23.75	22.98
		1	49	23.66	22.91
		25	0	22.81	21.80
		25	12	22.77	21.78
		25	25	22.74	21.75
		50	0	22.79	21.79
	1732.5	1	0	23.62	22.90
		1	24	23.62	22.91
		1	49	23.64	22.89
		25	0	22.66	21.71
		25	12	22.67	21.68
		25	25	22.65	21.68
		50	0	22.67	21.70
	1750.0	1	0	23.58	22.97
		1	24	23.58	22.94
		1	49	23.48	22.84
		25	0	22.61	21.65
		25	12	22.57	21.65
		25	25	22.52	21.59
		50	0	22.57	21.66
15	1717.5	1	0	23.76	22.92
		1	37	23.72	22.96
		1	74	23.57	22.82
		37	0	22.86	21.82
		37	18	22.81	21.79
		37	38	22.75	21.71
		75	0	22.81	21.78
	1732.5	1	0	23.65	22.89
		1	37	23.65	22.93
		1	74	23.63	22.89
		37	0	22.75	21.74
		37	18	22.74	21.72
		37	38	22.72	21.71
		75	0	22.75	21.74
	1747.5	1	0	23.59	22.88
		1	37	23.63	22.96
		1	74	23.53	22.76
		37	0	22.68	21.70
		37	18	22.70	21.70
		37	38	22.64	21.65
		75	0	22.66	21.67
20	1720.0	1	0	23.91	22.87
		1	49	23.81	22.94
		1	99	23.65	22.77
		50	0	22.80	21.78
		50	25	22.71	21.69
		50	50	22.63	21.64
		100	0	22.70	21.71
	1732.5	1	0	23.80	22.94
		1	49	23.75	22.89
		1	99	23.70	22.86
		50	0	22.69	21.71
		50	25	22.70	21.69
		50	50	22.71	21.74
		100	0	22.69	21.70

	1745.0	1	0	23.71	22.99
		1	49	23.72	22.86
		1	99	23.60	22.87
		50	0	22.66	21.74
		50	25	22.65	21.74
		50	50	22.62	21.71
		100	0	22.61	21.67

## 4.2. Manufacturing tolerance

<b>GSM 850 GPRS (GMSK) (Burst Average Power)</b>				
Channel		128	190	251
1 Txslot	Target (dBm)	32.0	32.0	32.0
	Tolerance $\pm$ (dB)	1.0	1.0	1.0
2 Txslot	Target (dBm)	30.0	30.	30.0
	Tolerance $\pm$ (dB)	1.0	1.0	1.0
3 Txslot	Target (dBm)	29.0	29.0	29.0
	Tolerance $\pm$ (dB)	1.0	1.0	1.0
4 Txslot	Target (dBm)	27.0	27.0	27.0
	Tolerance $\pm$ (dB)	1.0	1.0	1.0
<b>GSM 850 EDGE (8PSK) (Burst Average Power)</b>				
Channel		128	190	251
1 Txslot	Target (dBm)	25.0	25.0	25.0
	Tolerance $\pm$ (dB)	1.0	1.0	1.0
2 Txslot	Target (dBm)	24.0	24.0	24.0
	Tolerance $\pm$ (dB)	1.0	1.0	1.0
3 Txslot	Target (dBm)	23.0	23.0	23.0
	Tolerance $\pm$ (dB)	1.0	1.0	1.0
4 Txslot	Target (dBm)	22.0	22.0	22.0
	Tolerance $\pm$ (dB)	1.0	1.0	1.0
<b>GSM 1900 GPRS (GMSK) (Burst Average Power)</b>				
Channel		512	661	810
1 Txslot	Target (dBm)	30.0	30.0	30.0
	Tolerance $\pm$ (dB)	1.0	1.0	1.0
2 Txslot	Target (dBm)	29.0	29.0	29.0
	Tolerance $\pm$ (dB)	1.0	1.0	1.0
3 Txslot	Target (dBm)	28.0	28.0	28.0
	Tolerance $\pm$ (dB)	1.0	1.0	1.0
4 Txslot	Target (dBm)	27.0	27.0	27.0
	Tolerance $\pm$ (dB)	1.0	1.0	1.0
<b>GSM 1900 EDGE (8PSK) (Burst Average Power)</b>				
Channel		512	661	810
1 Txslot	Target (dBm)	32.0	32.0	32.0
	Tolerance $\pm$ (dB)	1.0	1.0	1.0
2 Txslot	Target (dBm)	32.0	32.0	31.0
	Tolerance $\pm$ (dB)	1.0	1.0	1.0
3 Txslot	Target (dBm)	30.0	30.0	29.0
	Tolerance $\pm$ (dB)	1.0	1.0	1.0
4 Txslot	Target (dBm)	29.0	29.0	28.0
	Tolerance $\pm$ (dB)	1.0	1.0	1.0

**UMTS**

<b>UMTS Band V</b>			
Channel	Channel 4132	Channel 4183	Channel 4233
Target (dBm)	23.5	23.5	23.5
Tolerance $\pm$ (dB)	1.0	1.0	1.0
<b>UMTS Band V HSDPA(sub-test 1)</b>			
Channel	Channel 4132	Channel 4183	Channel 4233
Target (dBm)	22.0	22.0	22.0
Tolerance $\pm$ (dB)	1.0	1.0	1.0
<b>UMTS Band V HSDPA(sub-test 2)</b>			
Channel	Channel 4132	Channel 4183	Channel 4233
Target (dBm)	22.0	22.0	22.0
Tolerance $\pm$ (dB)	1.0	1.0	1.0
<b>UMTS Band V HSDPA(sub-test 3)</b>			
Channel	Channel 4132	Channel 4183	Channel 4233
Target (dBm)	22.0	22.0	22.0
Tolerance $\pm$ (dB)	1.0	1.0	1.0
<b>UMTS Band V HSDPA(sub-test 4)</b>			
Channel	Channel 4132	Channel 4183	Channel 4233
Target (dBm)	22.0	22.0	22.0
Tolerance $\pm$ (dB)	1.0	1.0	1.0
<b>UMTS Band V HSUPA(sub-test 1)</b>			
Channel	Channel 4132	Channel 4183	Channel 4233
Target (dBm)	22.0	22.0	22.0
Tolerance $\pm$ (dB)	1.0	1.0	1.0
<b>UMTS Band V HSUPA(sub-test 2)</b>			
Channel	Channel 4132	Channel 4183	Channel 4233
Target (dBm)	22.0	22.0	22.0
Tolerance $\pm$ (dB)	1.0	1.0	1.0
<b>UMTS Band V HSUPA(sub-test 3)</b>			
Channel	Channel 4132	Channel 4183	Channel 4233
Target (dBm)	22.0	22.0	22.0
Tolerance $\pm$ (dB)	1.0	1.0	1.0
<b>UMTS Band V HSUPA(sub-test 4)</b>			
Channel	Channel 4132	Channel 4183	Channel 4233
Target (dBm)	22.0	22.0	22.0
Tolerance $\pm$ (dB)	1.0	1.0	1.0
<b>UMTS Band V HSUPA(sub-test 5)</b>			
Channel	Channel 4132	Channel 4183	Channel 4233
Target (dBm)	22.0	22.0	22.0
Tolerance $\pm$ (dB)	1.0	1.0	1.0

<b>UMTS Band II</b>			
Channel	Channel 9262	Channel 9400	Channel 9538
Target (dBm)	23.5	23.5	23.5
Tolerance $\pm$ (dB)	1.0	1.0	1.0
<b>UMTS Band II HSDPA(sub-test 1)</b>			
Channel	Channel 9262	Channel 9400	Channel 9538
Target (dBm)	22.0	22.0	22.0
Tolerance $\pm$ (dB)	1.0	1.0	1.0
<b>UMTS Band II HSDPA(sub-test 2)</b>			
Channel	Channel 9262	Channel 9400	Channel 9538
Target (dBm)	22.0	22.0	22.0
Tolerance $\pm$ (dB)	1.0	1.0	1.0
<b>UMTS Band II HSDPA(sub-test 3)</b>			
Channel	Channel 9262	Channel 9400	Channel 9538
Target (dBm)	22.0	22.0	22.0
Tolerance $\pm$ (dB)	1.0	1.0	1.0
<b>UMTS Band II HSDPA(sub-test 4)</b>			
Channel	Channel 9262	Channel 9400	Channel 9538
Target (dBm)	22.0	22.0	22.0



Tolerance $\pm$ (dB)	1.0	1.0	1.0
<b>UMTS Band II HSUPA(sub-test 1)</b>			
Channel	Channel 9262	Channel 9400	Channel 9538
Target (dBm)	22.0	22.0	22.0
Tolerance $\pm$ (dB)	1.0	1.0	1.0
<b>UMTS Band II HSUPA(sub-test 2)</b>			
Channel	Channel 9262	Channel 9400	Channel 9538
Target (dBm)	22.0	22.0	22.0
Tolerance $\pm$ (dB)	1.0	1.0	1.0
<b>UMTS Band II HSUPA(sub-test 3)</b>			
Channel	Channel 9262	Channel 9400	Channel 9538
Target (dBm)	22.0	22.0	22.0
Tolerance $\pm$ (dB)	1.0	1.0	1.0
<b>UMTS Band II HSUPA(sub-test 4)</b>			
Channel	Channel 9262	Channel 9400	Channel 9538
Target (dBm)	22.0	22.0	22.0
Tolerance $\pm$ (dB)	1.0	1.0	1.0
<b>UMTS Band II HSUPA(sub-test 5)</b>			
Channel	Channel 9262	Channel 9400	Channel 9538
Target (dBm)	22.0	22.0	22.0
Tolerance $\pm$ (dB)	1.0	1.0	1.0

**LTE Band 2**

<b>BW:1.4MHz [&lt;RB=1&gt;]</b>						
Channel	Channel 18607		Channel 18900		Channel 19193	
	QPSK	16QAM	QPSK	16QAM	QPSK	16QAM
Target (dBm)	23.0	22.0	23.0	22.0	23.0	22.0
Tolerance $\pm$ (dB)	1.0	1.0	1.0	1.0	1.0	1.0
<b>BW:1.4MHz [&lt;RB=3&gt;, &lt;RB=6&gt;]</b>						
Channel	Channel 18607		Channel 18900		Channel 19193	
	QPSK	16QAM	QPSK	16QAM	QPSK	16QAM
Target (dBm)	23.0	22.0	23.0	22.0	23.0	22.0
Tolerance $\pm$ (dB)	1.0	1.0	1.0	1.0	1.0	1.0
<b>BW:3MHz [&lt;RB=1&gt;]</b>						
Channel	Channel 18615		Channel 18900		Channel 19185	
	QPSK	16QAM	QPSK	16QAM	QPSK	16QAM
Target (dBm)	23.0	22.0	23.0	22.0	23.0	22.0
Tolerance $\pm$ (dB)	1.0	1.0	1.0	1.0	1.0	1.0
<b>BW:3MHz [&lt;RB=8&gt;, &lt;RB=15&gt;]</b>						
Channel	Channel 18615		Channel 18900		Channel 19185	
	QPSK	16QAM	QPSK	16QAM	QPSK	16QAM
Target (dBm)	22.0	21.0	22.0	21.0	22.0	21.0
Tolerance $\pm$ (dB)	1.0	1.0	1.0	1.0	1.0	1.0
<b>BW:5MHz [&lt;RB=1&gt;]</b>						
Channel	Channel 18625		Channel 18900		Channel 19175	
	QPSK	16QAM	QPSK	16QAM	QPSK	16QAM
Target (dBm)	23.0	22.0	23.0	22.0	23.0	22.0
Tolerance $\pm$ (dB)	1.0	1.0	1.0	1.0	1.0	1.0
<b>BW:5MHz [&lt;RB=12&gt;, &lt;RB=25&gt;]</b>						
Channel	Channel 18625		Channel 18900		Channel 19175	
	QPSK	16QAM	QPSK	16QAM	QPSK	16QAM
Target (dBm)	22.0	21.0	22.0	21.0	22.0	21.0
Tolerance $\pm$ (dB)	1.0	1.0	1.0	1.0	1.0	1.0
<b>BW:10MHz [&lt;RB=1&gt;]</b>						
Channel	Channel 18650		Channel 18900		Channel 19150	
	QPSK	16QAM	QPSK	16QAM	QPSK	16QAM
Target (dBm)	23.0	22.0	23.0	22.0	23.0	22.0
Tolerance $\pm$ (dB)	1.0	1.0	1.0	1.0	1.0	1.0
<b>BW:10MHz [&lt;RB=25&gt;, &lt;RB=50&gt;]</b>						
Channel	Channel 18650		Channel 18900		Channel 19150	

	QPSK	16QAM	QPSK	16QAM	QPSK	16QAM
Target (dBm)	22.0	21.0	22.0	21.0	22.0	21.0
Tolerance $\pm$ (dB)	1.0	1.0	1.0	1.0	1.0	1.0
<b>BW:15MHz [&lt;RB=1&gt;]</b>						
Channel	Channel 18675		Channel 18900		Channel 19125	
	QPSK	16QAM	QPSK	16QAM	QPSK	16QAM
Target (dBm)	23.0	22.0	23.0	22.0	23.0	22.0
Tolerance $\pm$ (dB)	1.0	1.0	1.0	1.0	1.0	1.0
<b>BW:15MHz [&lt;RB=37&gt;, &lt;RB=75&gt;]</b>						
Channel	Channel 18675		Channel 18900		Channel 19125	
	QPSK	16QAM	QPSK	16QAM	QPSK	16QAM
Target (dBm)	22.0	22.0	23.0	21.0	22.0	21.0
Tolerance $\pm$ (dB)	1.0	1.0	1.0	1.0	1.0	1.0
<b>BW:20MHz [&lt;RB=1&gt;]</b>						
Channel	Channel 18700		Channel 18900		Channel 19100	
	QPSK	16QAM	QPSK	16QAM	QPSK	16QAM
Target (dBm)	23.0	22.0	23.0	22.0	23.0	22.0
Tolerance $\pm$ (dB)	1.0	1.0	1.0	1.0	1.0	1.0
<b>BW:20MHz [&lt;RB=50&gt;, &lt;RB=100&gt;]</b>						
Channel	Channel 18700		Channel 18900		Channel 19100	
	QPSK	16QAM	QPSK	16QAM	QPSK	16QAM
Target (dBm)	22.0	21.0	22.0	21.0	22.0	21.0
Tolerance $\pm$ (dB)	1.0	1.0	1.0	1.0	1.0	1.0

**LTE Band 4**

<b>BW:1.4MHz [&lt;RB=1&gt;]</b>						
Channel	Channel 19957		Channel 20175		Channel 20393	
	QPSK	16QAM	QPSK	16QAM	QPSK	16QAM
Target (dBm)	23.0	22.0	23.0	22.0	23.0	22.0
Tolerance $\pm$ (dB)	1.0	1.0	1.0	1.0	1.0	1.0
<b>BW:1.4MHz [&lt;RB=3&gt;, &lt;RB=6&gt;]</b>						
Channel	Channel 19957		Channel 20175		Channel 20393	
	QPSK	16QAM	QPSK	16QAM	QPSK	16QAM
Target (dBm)	23.0	22.0	23.0	22.0	23.0	22.0
Tolerance $\pm$ (dB)	1.0	1.0	1.0	1.0	1.0	1.0
<b>BW:3MHz [&lt;RB=1&gt;]</b>						
Channel	Channel 19965		Channel 20175		Channel 20385	
	QPSK	16QAM	QPSK	16QAM	QPSK	16QAM
Target (dBm)	23.0	22.0	23.0	22.0	23.0	22.0
Tolerance $\pm$ (dB)	1.0	1.0	1.0	1.0	1.0	1.0
<b>BW:3MHz [&lt;RB=8&gt;, &lt;RB=15&gt;]</b>						
Channel	Channel 19965		Channel 20175		Channel 20385	
	QPSK	16QAM	QPSK	16QAM	QPSK	16QAM
Target (dBm)	22.0	21.0	22.0	21.0	22.0	21.0
Tolerance $\pm$ (dB)	1.0	1.0	1.0	1.0	1.0	1.0
<b>BW:5MHz [&lt;RB=1&gt;]</b>						
Channel	Channel 19975		Channel 20175		Channel 20375	
	QPSK	16QAM	QPSK	16QAM	QPSK	16QAM
Target (dBm)	23.0	22.0	23.0	22.0	23.0	22.0
Tolerance $\pm$ (dB)	1.0	1.0	1.0	1.0	1.0	1.0
<b>BW:5MHz [&lt;RB=12&gt;, &lt;RB=25&gt;]</b>						
Channel	Channel 19975		Channel 20175		Channel 20375	
	QPSK	16QAM	QPSK	16QAM	QPSK	16QAM
Target (dBm)	22.0	21.0	22.0	21.0	22.0	21.0
Tolerance $\pm$ (dB)	1.0	1.0	1.0	1.0	1.0	1.0
<b>BW:10MHz [&lt;RB=1&gt;]</b>						
Channel	Channel 20000		Channel 20175		Channel 20350	
	QPSK	16QAM	QPSK	16QAM	QPSK	16QAM
Target (dBm)	23.0	22.0	23.0	22.0	23.0	22.0
Tolerance $\pm$ (dB)	1.0	1.0	1.0	1.0	1.0	1.0
<b>BW:10MHz [&lt;RB=25&gt;, &lt;RB=50&gt;]</b>						

Channel	Channel 20000		Channel 20175		Channel 20350	
	QPSK	16QAM	QPSK	16QAM	QPSK	16QAM
Target (dBm)	22.0	21.0	22.0	21.0	22.0	21.0
Tolerance ±(dB)	1.0	1.0	1.0	1.0	1.0	1.0
<b>BW:15MHz [&lt;RB=1&gt;]</b>						
Channel	Channel 20025		Channel 20175		Channel 20325	
	QPSK	16QAM	QPSK	16QAM	QPSK	16QAM
Target (dBm)	23.0	22.0	23.0	22.0	23.0	22.0
Tolerance ±(dB)	1.0	1.0	1.0	1.0	1.0	1.0
<b>BW:15MHz [&lt;RB=37&gt;, &lt;RB=75&gt;]</b>						
Channel	Channel 20025		Channel 20175		Channel 20325	
	QPSK	16QAM	QPSK	16QAM	QPSK	16QAM
Target (dBm)	22.0	21.0	22.0	21.0	22.0	21.0
Tolerance ±(dB)	1.0	1.0	1.0	1.0	1.0	1.0
<b>BW:20MHz [&lt;RB=1&gt;]</b>						
Channel	Channel 20050		Channel 20175		Channel 20300	
	QPSK	16QAM	QPSK	16QAM	QPSK	16QAM
Target (dBm)	23.0	22.0	23.0	22.0	23.0	22.0
Tolerance ±(dB)	1.0	1.0	1.0	1.0	1.0	1.0
<b>BW:20MHz [&lt;RB=50&gt;, &lt;RB=100&gt;]</b>						
Channel	Channel 20050		Channel 20175		Channel 20300	
	QPSK	16QAM	QPSK	16QAM	QPSK	16QAM
Target (dBm)	22.0	21.0	22.0	21.0	22.0	21.0
Tolerance ±(dB)	1.0	1.0	1.0	1.0	1.0	1.0

### 4.3. Transmit Antennas and SAR Measurement Position

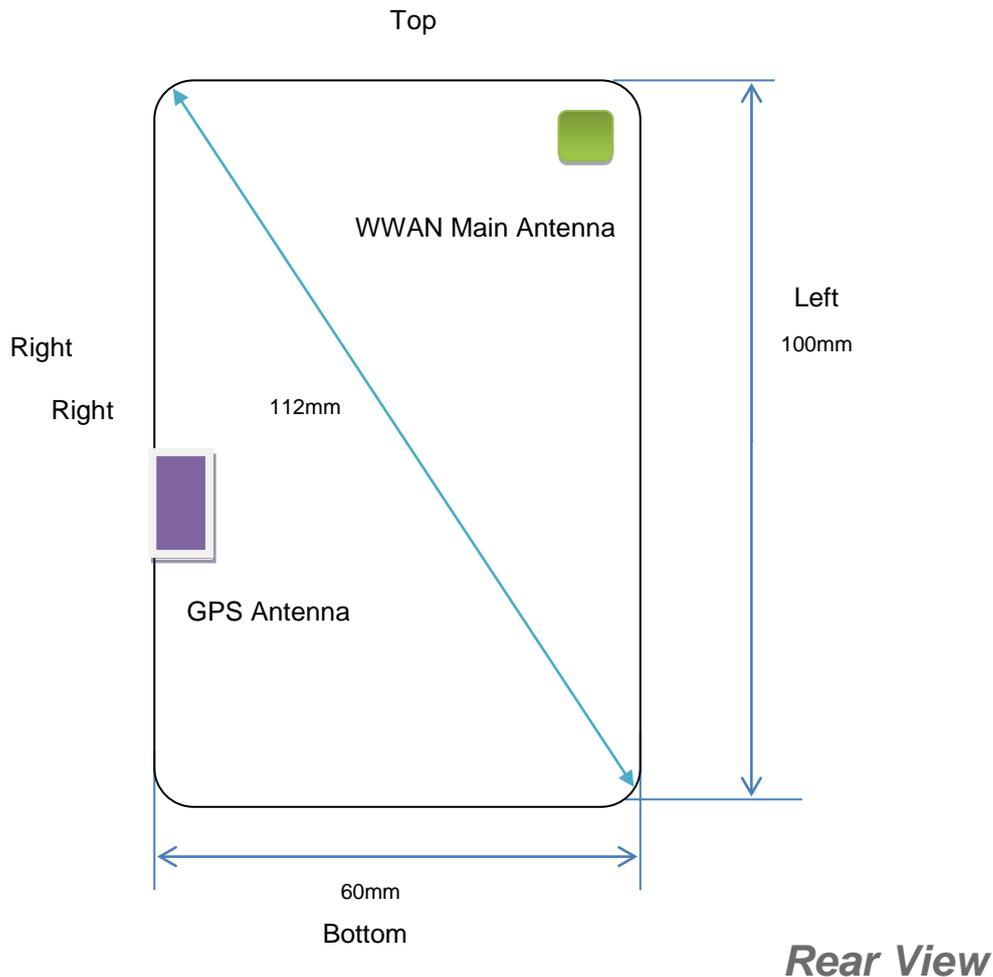

## Antenna information:

WWAN Main Antenna	GSM/UMTS/LTE TX/RX
GPS Antenna	GPS RX

## Note:

1). Per 941225 D07 UMPC Mini Tablet v01r02, UMPC mini-tablet devices must be tested for 1-g SAR on all surfaces and side edges with a transmitting antenna located at  $\leq 25$  mm from that surface or edge, at 5 mm separation from a flat phantom, for the data modes, wireless technologies and frequency bands supported by the device to determine SAR compliance. When 1-g SAR is tested at 5 mm, 10-g SAR is not required.

Distance of The Antenna to the EUT surface and edge (mm)						
Antennas	Front	Back	Top Side	Bottom Side	Left Side	Right Side
WWAN	<5	<5	<5	95	<5	50

Positions for SAR tests; Hotspot mode						
Antennas	Front	Back	Top Side	Bottom Side	Left Side	Right Side
WWAN	Yes	Yes	Yes	No	Yes	No

**General Note:** Referring to KDB 941225 D07 UMPC Mini Tablet v01r02, UMPC mini-tablet devices must be tested for 1-g SAR on all surfaces and side edges with a transmitting antenna located at  $\leq 25$  mm from that surface or edge, at 5 mm separation from a flat phantom

#### 4.4. SAR Measurement Results

The calculated SAR is obtained by the following formula:

$$\text{Reported SAR} = \text{Measured SAR} * 10^{(P_{\text{target}} - P_{\text{measured}})/10}$$

$$\text{Scaling factor} = 10^{(P_{\text{target}} - P_{\text{measured}})/10}$$

$$\text{Reported SAR} = \text{Measured SAR} * \text{Scaling factor}$$

Where

$P_{\text{target}}$  is the power of manufacturing upper limit;

$P_{\text{measured}}$  is the measured power;

Measured SAR is measured SAR at measured power which including power drift)

Reported SAR which including Power Drift and Scaling factor

#### Duty Cycle

Test Mode	Duty Cycle
GPRS850	1:2.67
GPRS1900	1:2
UMTS	1:1
LTE	1:1

#### 4.4.1 SAR Results

##### 4.4.1.1 Standalone SAR

**SAR Values [GSM 850]**

Ch.	Freq. (MHz)	Time slots	Test Position	Conducted Power (dBm)	Maximum Allowed Power (dBm)	Power Drift (%)	Scaling Factor	SAR <sub>1-g</sub> results(W/kg)		Graph Results
								Measured	Reported	
measured / reported SAR numbers - Body (distance 0mm)										
128	824.2	3Txslots	Front	29.26	30.00	-1.91	1.186	0.989	1.173	Plot 1
190	836.6	3Txslots		29.58	30.00	2.29	1.102	<b>1.122</b>	<b>1.236</b>	
251	848.8	3Txslots		29.57	30.00	-3.24	1.104	0.914	1.009	
128	824.2	3Txslots	Rear	29.26	30.00	4.02	1.186	0.829	0.983	
190	836.6	3Txslots		29.58	30.00	2.43	1.102	0.913	1.006	
251	848.8	3Txslots		29.57	30.00	-0.97	1.104	0.755	0.834	
128	824.2	3Txslots	Left	29.26	30.00	2.33	1.186	0.978	1.160	
190	836.6	3Txslots		29.58	30.00	2.13	1.102	1.095	1.207	
251	848.8	3Txslots		29.57	30.00	3.47	1.104	0.944	1.042	
190	836.6	3Txslots	Top	29.58	30.00	0.23	1.102	0.724	0.798	

**Remark:**

1. The value with block color is the maximum SAR Value of each test band.
2. The frame average of GPRS (3Tx slots) higher than other slots, tested at GPRS (4Tx slots) mode for head.
3. Per FCC KDB Publication 447498 D01, if the reported (scaled) SAR measured at the middle channel or highest output power channel for each test configuration is  $\leq 0.8$  W/kg then testing at the other channels is optional for such test configuration(s).

**SAR Values [GSM 1900]**

Ch.	Freq. (MHz)	time slots	Test Position	Conducted Power (dBm)	Maximum Allowed Power (dBm)	Power Drift (%)	Scaling Factor	SAR <sub>1-g</sub> results(W/kg)		Graph Results
								Measured	Reported	
measured / reported SAR numbers - Body (distance 0mm)										
512	1850.2	4Txslots	Front	27.75	28.00	4.35	1.059	<b>0.751</b>	<b>0.795</b>	Plot 2
512	1850.2	4Txslots	Rear	27.75	28.00	0.19	1.059	0.698	0.739	
512	1850.2	4Txslots	Left	27.75	28.00	-0.59	1.059	0.745	0.789	
512	1850.2	4Txslots	Top	27.75	28.00	1.06	1.059	0.433	0.459	

**Remark:**

1. The value with block color is the maximum SAR Value of each test band.
2. The frame average of GPRS (4Tx slots) higher than slots, tested at GPRS (4Tx slots) mode for head.
3. Per FCC KDB Publication 447498 D01, if the reported (scaled) SAR measured at the middle channel or highest output power channel for each test configuration is  $\leq 0.8$  W/kg then testing at the other channels is optional for such test configuration(s).

**SAR Values [WCDMA Band V]**

Ch.	Freq. (MHz)	Channel Type	Test Position	Conducted Power (dBm)	Maximum Allowed Power (dBm)	Power Drift (%)	Scaling Factor	SAR <sub>1-g</sub> results(W/kg)		Graph Results
								Measured	Reported	
measured / reported SAR numbers - Body (distance 0mm)										
4132	826.4	RMC*	Front	23.88	24.50	-3.44	1.153	0.734	0.846	Plot 3
4183	836.6	RMC*		23.75	24.50	0.60	1.189	0.835	0.993	
4233	846.6	RMC*		24.22	24.50	3.03	1.067	<b>1.023</b>	<b>1.092</b>	
4132	826.4	RMC*	Rear	23.88	24.50	-4.16	1.153	0.711	0.820	
4183	836.6	RMC*		23.75	24.50	-0.31	1.189	0.807	0.960	
4233	846.6	RMC*		24.22	24.50	-2.07	1.067	0.964	1.029	
4132	826.4	RMC*	Left	23.88	24.50	4.02	1.153	0.729	0.841	
4183	836.6	RMC*		23.75	24.50	-3.21	1.189	0.829	0.986	
4233	846.6	RMC*		24.22	24.50	2.97	1.067	0.997	1.064	
4233	846.6	RMC	Top	24.22	24.50	-2.95	1.067	0.722	0.770	

**Remark:**

1. The value with block color is the maximum SAR Value of each test band.

2. Per FCC KDB Publication 447498 D01, if the reported (scaled) SAR measured at the middle channel or highest output power channel for each test configuration is  $\leq 0.8$  W/kg then testing at the other channels is optional for such test configuration(s).

3. RMC\* - RMC 12.2kbps mode;

### SAR Values [WCDMA Band II]

Ch.	Freq. (MHz)	Channel Type	Test Position	Conducted Power (dBm)	Maximum Allowed Power (dBm)	Power Drift (%)	Scaling Factor	SAR <sub>1-g</sub> results(W/kg)		Graph Results
								Measured	Reported	
measured / reported SAR numbers - Body (distance 0mm)										
9538	1907.6	RMC*	Front	24.05	24.50	-0.43	1.109	<b>0.669</b>	<b>0.742</b>	Plot 4
9538	1907.6	RMC*	Rear	24.05	24.50	-0.15	1.109	0.621	0.689	
9538	1907.6	RMC*	Left	24.05	24.50	0.23	1.109	0.658	0.730	
9538	1907.6	RMC*	Top	24.05	24.50	-2.20	1.109	0.332	0.368	

Remark:

1. The value with block color is the maximum SAR Value of each test band.

2. Per FCC KDB Publication 447498 D01, if the reported (scaled) SAR measured at the middle channel or highest output power channel for each test configuration is  $\leq 0.8$  W/kg then testing at the other channels is optional for such test configuration(s).

3. RMC\* - RMC 12.2kbps mode;

### SAR Values [LTE Band 2]

Ch.	Freq. (MHz)	Channel Type (20M)	Test Position	Conducted Power (dBm)	Maximum Allowed Power (dBm)	Power Drift (%)	Scaling Factor	SAR <sub>1-g</sub> results(W/kg)		Graph Results
								Measured	Reported	
measured / reported SAR numbers - Body (distance 0mm)										
19100	1900.0	1RB	Front	23.88	24.00	0.82	1.028	<b>0.660</b>	<b>0.678</b>	Plot 5
19100	1900.0	1RB	Rear	23.88	24.00	1.16	1.028	0.611	0.628	
19100	1900.0	1RB	Left	23.88	24.00	-0.53	1.028	0.641	0.659	
19100	1900.0	1RB	Top	23.88	24.00	1.21	1.028	0.259	0.266	
18900	1880.0	50%RB	Front	22.85	23.00	1.25	1.035	0.493	0.510	
18900	1880.0	50%RB	Rear	22.85	23.00	-1.01	1.035	0.459	0.475	
18900	1880.0	50%RB	Left	22.85	23.00	1.13	1.035	0.483	0.500	
18900	1880.0	50%RB	Top	22.85	23.00	2.02	1.035	0.213	0.220	

Remark:

1. The value with block color is the maximum SAR Value of each test band.

2. Per FCC KDB Publication 447498 D01, if the reported (scaled) SAR measured at the middle channel or highest output power channel for each test configuration is  $\leq 0.8$  W/kg then testing at the other channels is optional for such test configuration(s).

### SAR Values [LTE Band 4]

Ch.	Freq. (MHz)	Channel Type (20M)	Test Position	Conducted Power (dBm)	Maximum Allowed Power (dBm)	Power Drift (%)	Scaling Factor	SAR <sub>1-g</sub> results(W/kg)		Graph Results
								Measured	Reported	
measured / reported SAR numbers - Body (distance 0mm)										
20050	1720.0	1RB	Front	23.91	24.00	0.79	1.021	<b>0.774</b>	<b>0.790</b>	Plot 6
20050	1720.0	1RB	Rear	23.91	24.00	-2.60	1.021	0.711	0.726	
20050	1720.0	1RB	Left	23.91	24.00	0.63	1.021	0.763	0.779	
20050	1720.0	1RB	Top	23.91	24.00	-1.25	1.021	0.388	0.396	
20050	1720.0	50%RB	Front	22.80	23.00	1.23	1.047	0.561	0.587	
20050	1720.0	50%RB	Rear	22.80	23.00	0.53	1.047	0.536	0.561	
20050	1720.0	50%RB	Left	22.80	23.00	1.67	1.047	0.552	0.578	
20050	1720.0	50%RB	Top	22.80	23.00	2.16	1.047	0.251	0.263	

Remark:

1. The value with block color is the maximum SAR Value of each test band.

2. Per FCC KDB Publication 447498 D01, if the reported (scaled) SAR measured at the middle channel or highest output power channel for each test configuration is  $\leq 0.8$  W/kg then testing at the other channels is optional for such test configuration(s).

#### 4.4.1.2 Simultaneous SAR

The device only support GSM/UMTS/LTE transmit antenna, no need consider simultaneous transmit.

#### 4.5. SAR Measurement Variability

According to KDB865664, Repeated measurements are required only when the measured SAR is  $\geq 0.80$  W/kg. If the measured SAR value of the initial repeated measurement is  $< 1.45$  W/kg with  $\leq 20\%$  variation, only one repeated measurement is required to reaffirm that the results are not expected to have substantial variations, which may introduce significant compliance concerns. A second repeated measurement is required only if the measured result for the initial repeated measurement is within 10% of the SAR limit and vary by more than 20%, which are often related to device and measurement setup difficulties. The following procedures are applied to determine if repeated measurements are required. The same procedures should be adapted for measurements according to extremity and occupational exposure limits by applying a factor of 2.5 for extremity exposure and a factor of 5 for occupational exposure to the corresponding SAR thresholds.19 The repeated measurement results must be clearly identified in the SAR report. All measured SAR, including the repeated results, must be considered to determine compliance and for reporting according to KDB 690783. Repeated measurement is not required when the original highest measured SAR is  $< 0.80$  W/kg; steps 2) through 4) do not apply.

- 3) When the original highest measured SAR is  $\geq 0.80$  W/kg, repeat that measurement once.
- 4) Perform a second repeated measurement only if the ratio of largest to smallest SAR for the original and first repeated measurements is  $> 1.20$  or when the original or repeated measurement is  $\geq 1.45$  W/kg ( $\sim 10\%$  from the 1-g SAR limit).
- 5) Perform a third repeated measurement only if the original, first or second repeated measurement is  $\geq 1.5$  W/kg and the ratio of largest to smallest SAR for the original, first and second repeated measurements is  $> 1.20$ .
- 6) Perform a third repeated measurement only if the original, first or second repeated measurement is  $\geq 1.5$  W/kg and the ratio of largest to smallest SAR for the original, first and second repeated measurements is  $> 1.20$ .

Frequency Band (MHz)	Air Interface	RF Exposure Configuration	Test Position	Repeated SAR (yes/no)	Highest Measured SAR <sub>1-g</sub> (W/Kg)	First Repeated	
						Measured SAR <sub>1-g</sub> (W/Kg)	Largest to Smallest SAR Ratio
850	GSM850	Standalone	Body- Front	yes	1.122	1.147	1.02
	WCDMA Band V	Standalone	Body- Front	yes	1.023	0.996	0.97
1900	GSM1900	Standalone	Body-Front	no	0.751	n/a	n/a
	WCDMA Band II	Standalone	Body-Front	no	0.669	n/a	n/a
	LTE Band 2	Standalone	Body-Front	no	0.660	n/a	n/a
1750	LTE Band 4	Standalone	Body-Front	no	0.774	n/a	n/a

#### Remark:

1. Second Repeated Measurement is not required since the ratio of the largest to smallest SAR for the original and first repeated measurement is not  $> 1.20$  or 3 (1-g or 10-g respectively)

#### 4.6. General description of test procedures

1. The DUT is tested using CMU 200 (CMW 500) communications testers as controller unit to set test channels and maximum output power to the DUT, as well as for measuring the conducted peak power.
2. Test positions as described in the tables above are in accordance with the specified test standard.
3. Tests in body position were performed in that configuration, which generates the highest time based averaged output power (see conducted power results).
4. UMTS was tested in RMC mode with 12.2 kbit/s and TPC bits set to 'all 1'.
5. According to FCC KDB pub 941225 D07 this device has been tested with 10 mm distance to the phantom for operation in WiFi hot spot mode.
6. Per FCC KDB pub 941225 D06 "UMPC mini-tablet devices must be tested for 1-g SAR on all surfaces and side edges with a transmitting antenna located at  $\leq 25$  mm from that surface or edge, at 5 mm separation from a flat phantom, for the data modes, wireless technologies and frequency bands supported by the device to determine SAR compliance. When 1-g SAR is tested at 5 mm, 10-g SAR is not required".

7. According to KDB 447498 D01 testing of other required channels within the operating mode of a frequency band is not required when the reported 1-g or 10-g SAR for the mid-band or highest output power channel is:
  - $\leq 0.8$  W/kg or 2.0 W/kg, for 1-g or 10-g respectively, when the transmission band is  $\leq 100$  MHz
  - $\leq 0.6$  W/kg or 1.5 W/kg, for 1-g or 10-g respectively, when the transmission band is between 100 MHz and 200 MHz
  - $\leq 0.4$  W/kg or 1.0 W/kg, for 1-g or 10-g respectively, when the transmission band is  $\geq 200$  MHz
8. Per KDB648474 D04 require when the reported SAR for a body-worn accessory, measured without a headset connected to the handset, is  $< 1.2$  W/kg.

#### **4.7. Measurement Uncertainty (300MHz-3GHz)**

Not required as SAR measurement uncertainty analysis is required in SAR reports only when the highest measured SAR in a frequency band is  $\geq 1.5$  W/kg for 1-g SAR according to KDB865664D01.



### 4.8. System Check Results

Test mode:835MHz(Body)  
 Product Description:Validation  
 Model:Dipole SID835  
 E-Field Probe: SSE2(SN45/15 EPGO281)  
 Test Date: October 11, 2017

Medium(liquid type)	MSL_850
Frequency (MHz)	835.0000
Relative permittivity (real part)	55.25
Conductivity (S/m)	0.98
Input power	100mW
Crest Factor	1.0
Conversion Factor	1.85
Variation (%)	-0.200000
SAR 10g (W/Kg)	0.625071
SAR 1g (W/Kg)	0.951868
<b>SURFACE SAR</b>	<b>VOLUME SAR</b>

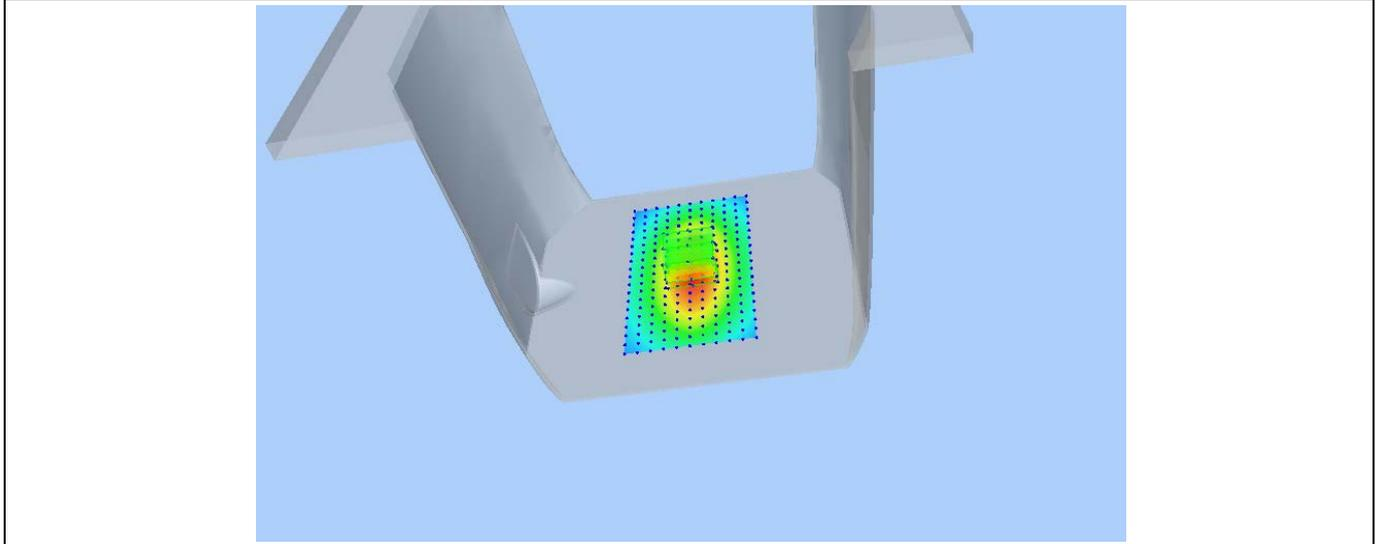
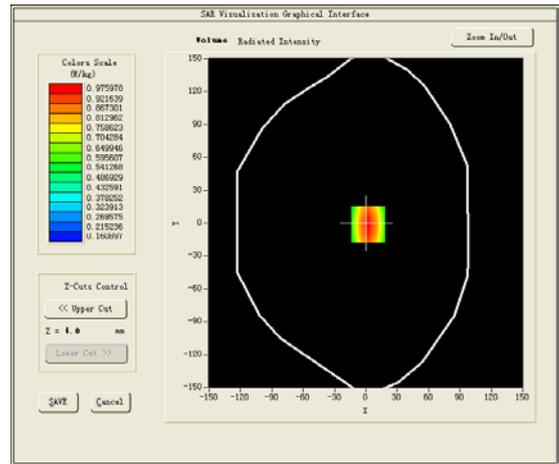
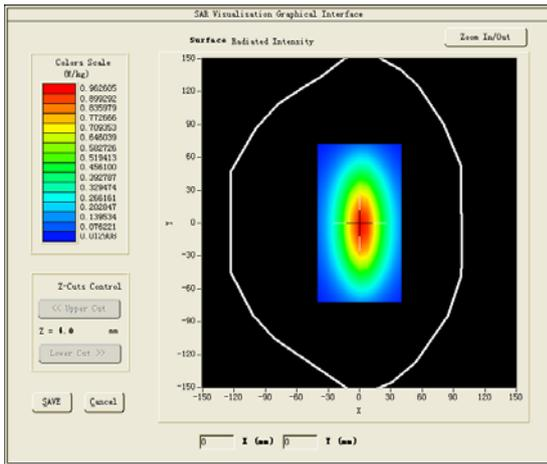

Test mode:1800MHz(Body)  
 Product Description:Validation  
 Model :Dipole SID1800  
 E-Field Probe: SSE2(SN45/15 EPGO281)  
 Test Date: October 13, 2017

Medium(liquid type)	MSL_1800
Frequency (MHz)	1800.000000
Relative permittivity (real part)	53.37
Conductivity (S/m)	1.55
Input power	100mW
Crest Factor	1.0
Conversion Factor	1.87
Variation (%)	-0.600000
SAR 10g (W/Kg)	2.093725
SAR 1g (W/Kg)	4.017778

**SURFACE SAR**

**VOLUME SAR**

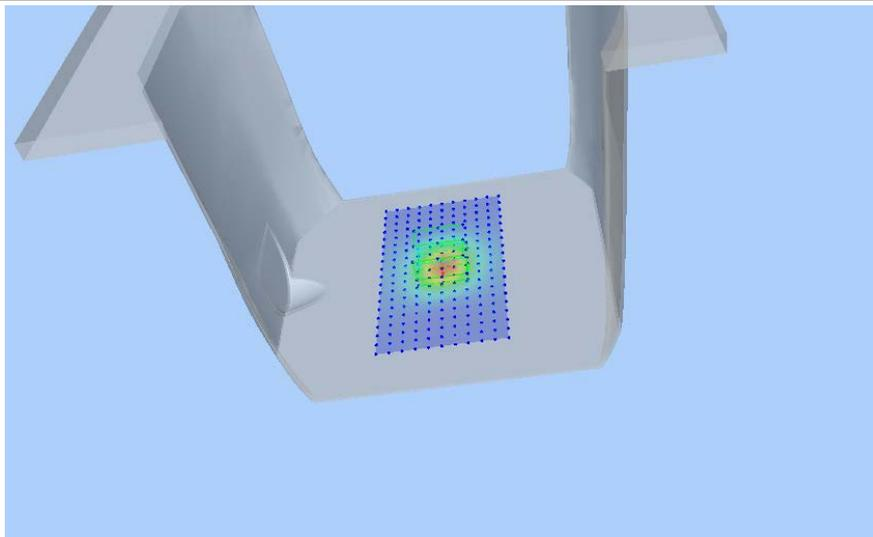
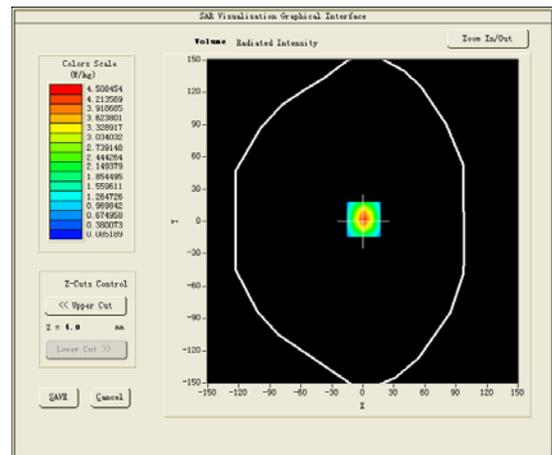
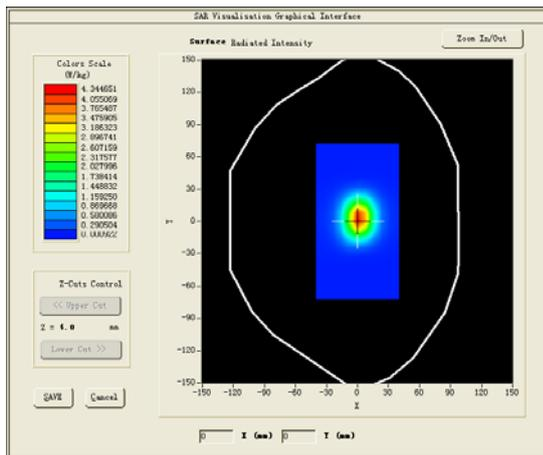

Test mode:1900MHz(Body)  
 Product Description:Validation  
 Model :Dipole SID1900  
 E-Field Probe: SSE2(SN45/15 EPGO281)  
 Test Date: October 12, 2017

Medium(liquid type)	MSL_1900
Frequency (MHz)	1900.0000
Relative permittivity (real part)	53.11
Conductivity (S/m)	1.58
Input power	100mW
Crest Factor	1.0
Conversion Factor	2.16
Variation (%)	-2.3300000
SAR 10g (W/Kg)	2.1322467
SAR 1g (W/Kg)	4.2905105

**SURFACE SAR**

**VOLUME SAR**

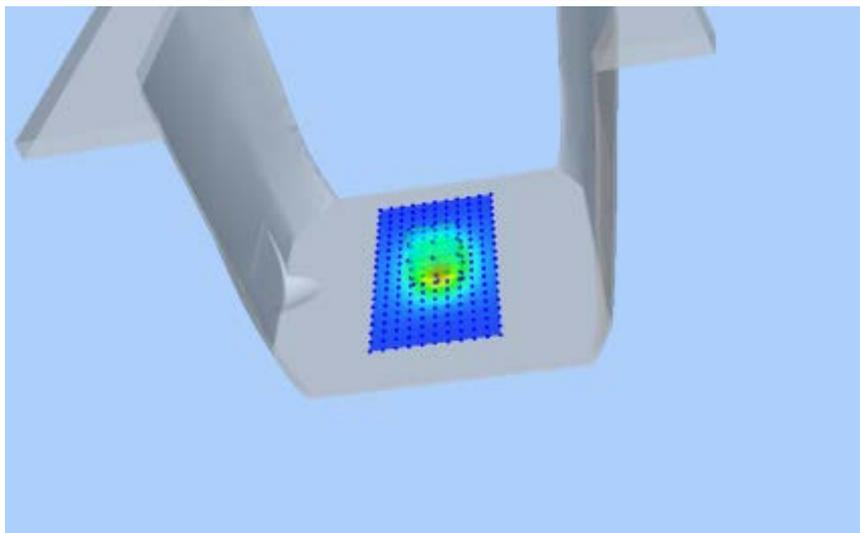
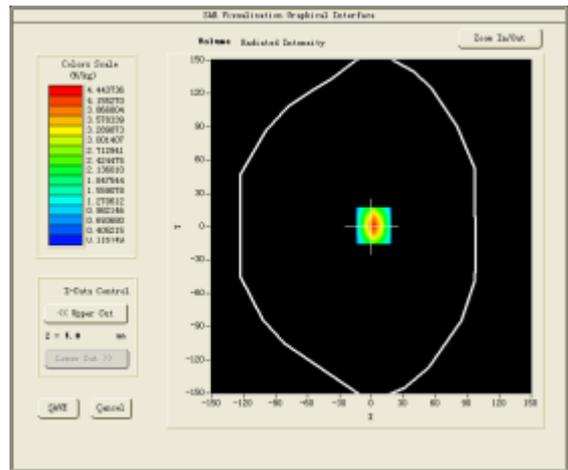
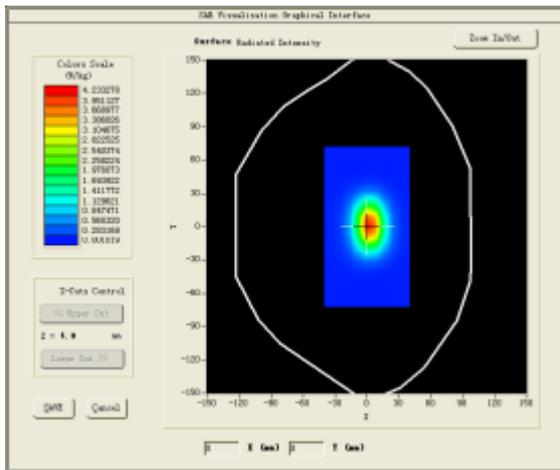

### 4.10 SAR Test Graph Results

SAR plots for the highest measured SAR in each exposure configuration, wireless mode and frequency band combination according to FCC KDB 865664 D02;

#1

Test Mode: GSM850MHz, Middle Channel(Body Front Side)

Product Description: Personal GPS Tracker

Model: GK310

Test Date: October 11, 2017

Medium(liquid type)	MSL_850
Frequency (MHz)	836.600000
Relative permittivity (real part)	55.25
Conductivity (S/m)	0.98
E-Field Probe	SN45/15 EPGO281
Crest Factor	1.85
Conversion Factor	5.36
Sensor	4mm
Area Scan	dx=8mm dy=8mm
Zoom Scan	5x5x7,dx=8mm dy=8mm dz=5mm
Variation (%)	2.290000
SAR 10g (W/Kg)	0.603295
SAR 1g (W/Kg)	1.121774
SURFACE SAR	VOLUME SAR

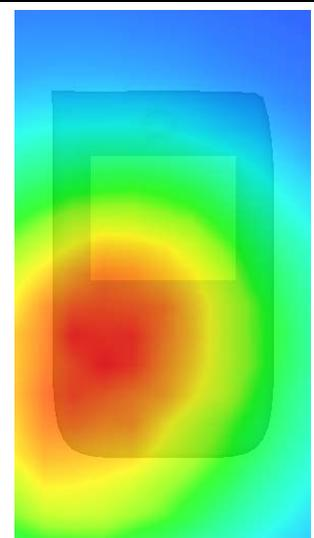
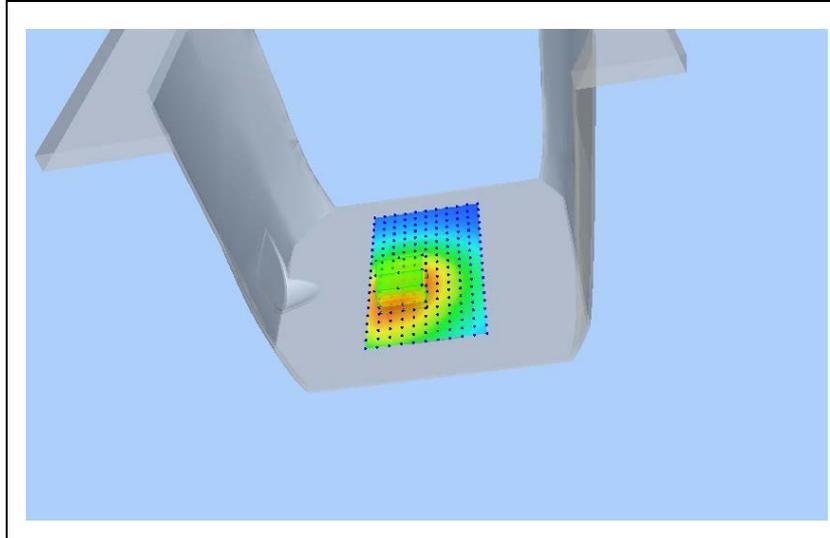
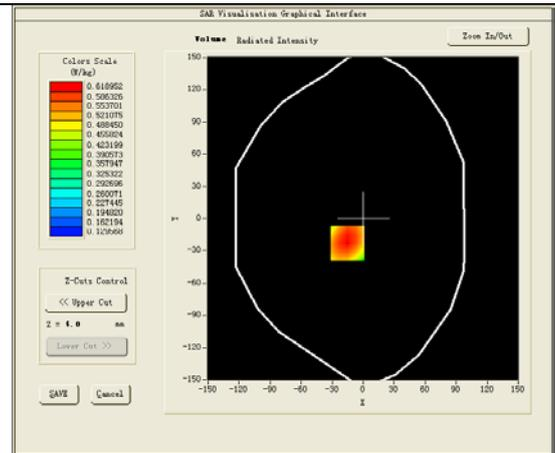
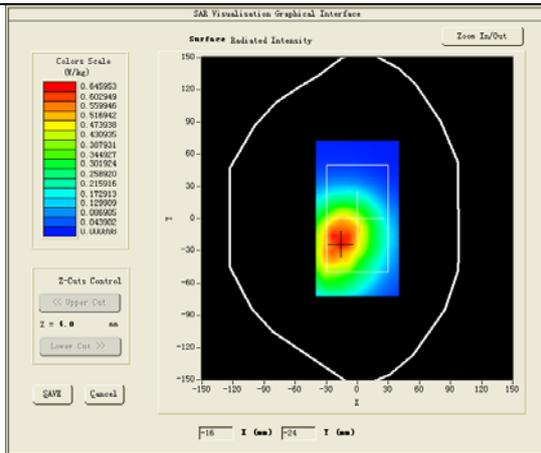

#2

Test Mode: GPRS1900MHz, Low Channel (Body Front Side)

Product Description: Personal GPS Tracker

Model: GK310

Test Date: October 12, 2017

Medium(liquid type)	MSL_1900
Frequency (MHz)	1850.200000
Relative permittivity (real part)	1.56
Conductivity (S/m)	53.29
E-Field Probe	SN45/15 EPGO281
Crest Factor	2.67
Conversion Factor	4.42
Sensor	4mm
Area Scan	dx=8mm dy=8mm
Zoom Scan	5x5x7,dx=8mm dy=8mm dz=5mm
Variation (%)	4.350000
SAR 10g (W/Kg)	0.304812
SAR 1g (W/Kg)	0.750864
<b>SURFACE SAR</b>	<b>VOLUME SAR</b>

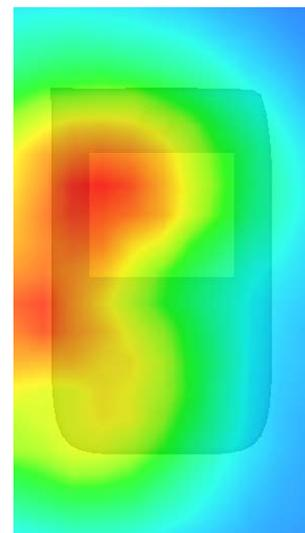
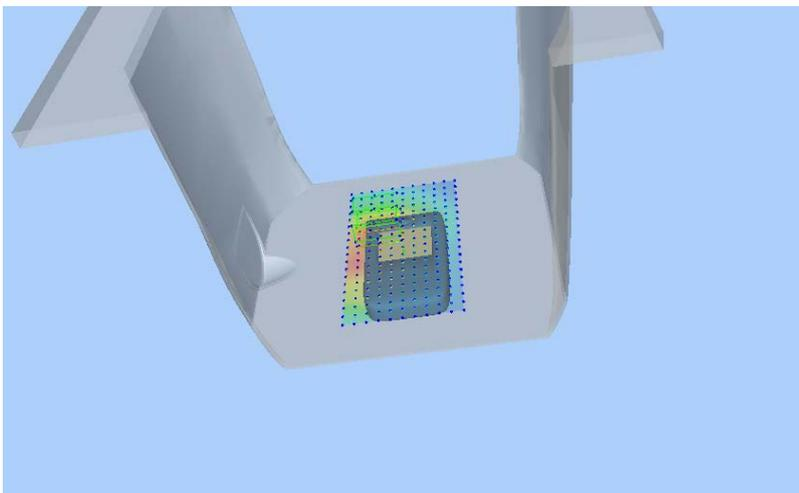
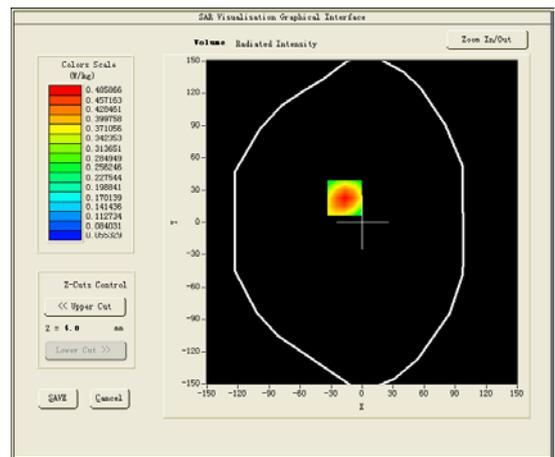
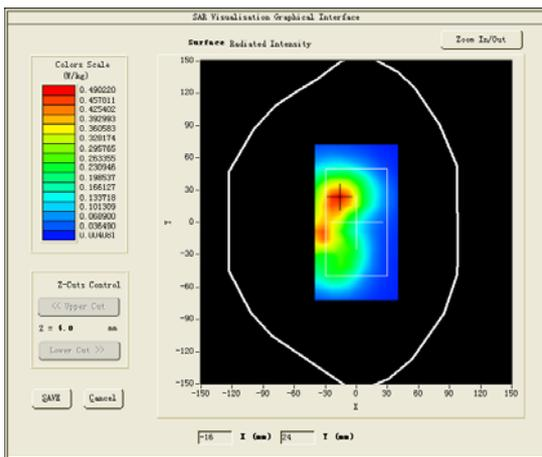

#3

Test Mode: WCDMA Band V, High Channel (Body Front Side)  
 Product Description: Personal GPS Tracker  
 Model: GK310  
 Test Date: October 11, 2017

Medium(liquid type)	MSL_850
Frequency (MHz)	846.600000
Relative permittivity (real part)	55.13
Conductivity (S/m)	0.99
E-Field Probe	SN45/15 EPGO281
Crest Factor	1.0
Conversion Factor	1.85
Sensor	4mm
Area Scan	dx=8mm dy=8mm
Zoom Scan	5x5x7,dx=8mm dy=8mm dz=5mm
Variation (%)	3.030000
SAR 10g (W/Kg)	0.522492
SAR 1g (W/Kg)	1.023468
<b>SURFACE SAR</b>	<b>VOLUME SAR</b>

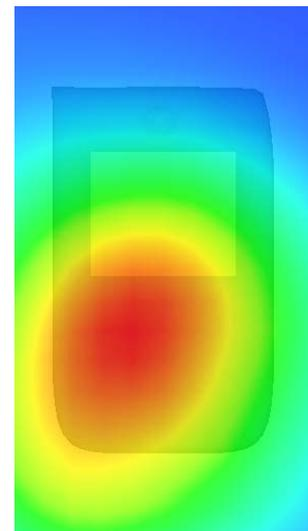
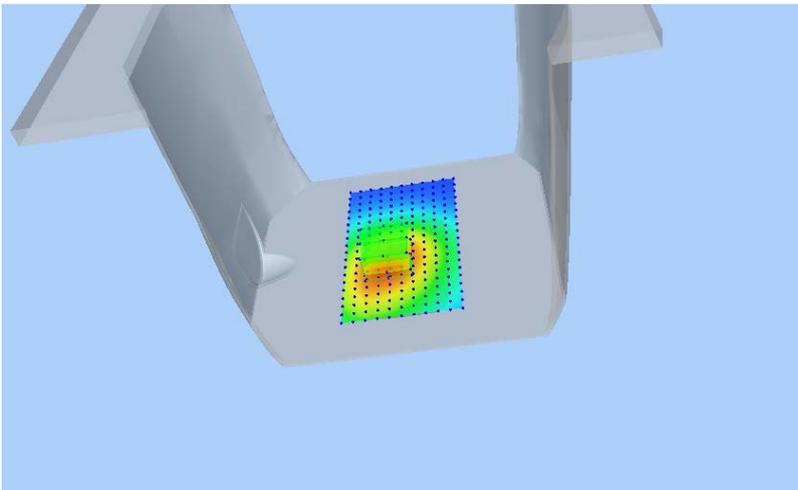
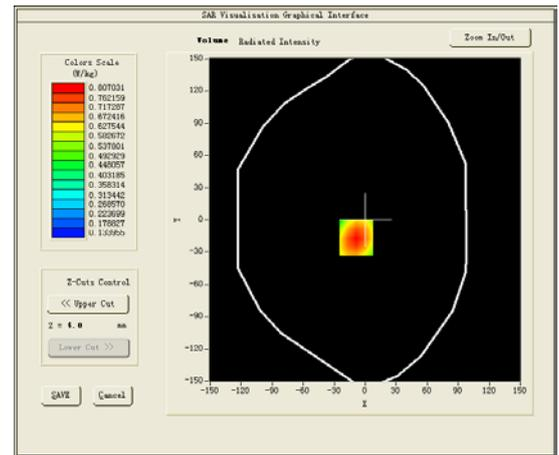
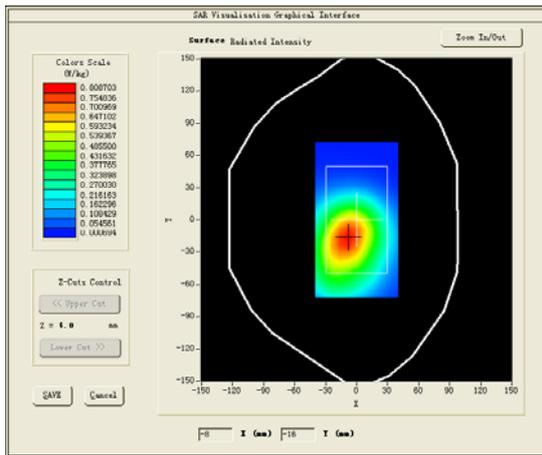

#4

Test Mode: WCDMA Band II, High Channel (Body Front Side)  
 Product Description: Personal GPS Tracker  
 Model: GK310  
 Test Date: October 12, 2017

Medium(liquid type)	MSL_1900
Frequency (MHz)	1907.600000
Relative permittivity (real part)	53.04
Conductivity (S/m)	1.58
E-Field Probe	SN45/15 EPGO281
Crest Factor	1.0
Conversion Factor	2.16
Sensor	4mm
Area Scan	dx=8mm dy=8mm
Zoom Scan	5x5x7,dx=8mm dy=8mm dz=5mm
Variation (%)	-0.430000
SAR 10g (W/Kg)	0.368955
SAR 1g (W/Kg)	0.668726
<b>SURFACE SAR</b>	<b>VOLUME SAR</b>

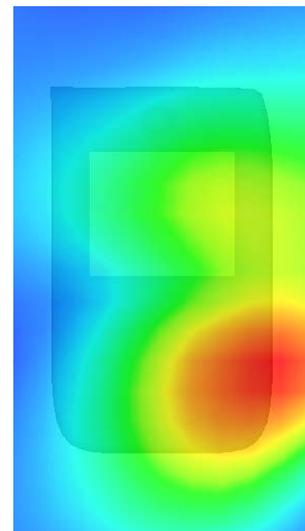
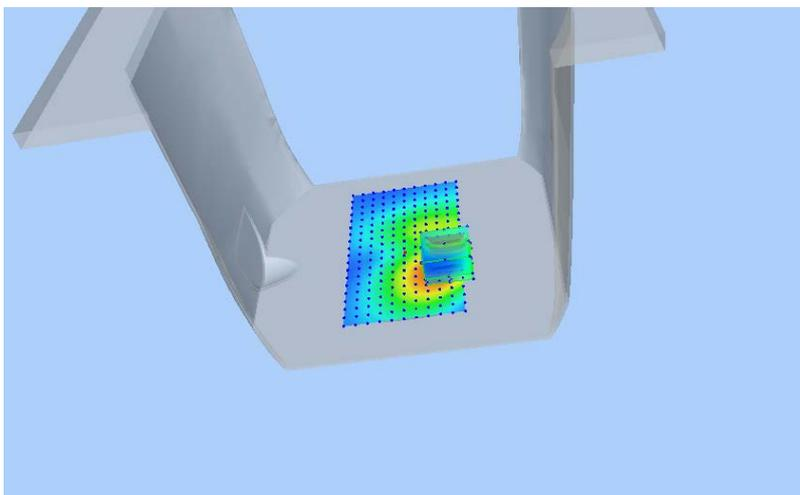
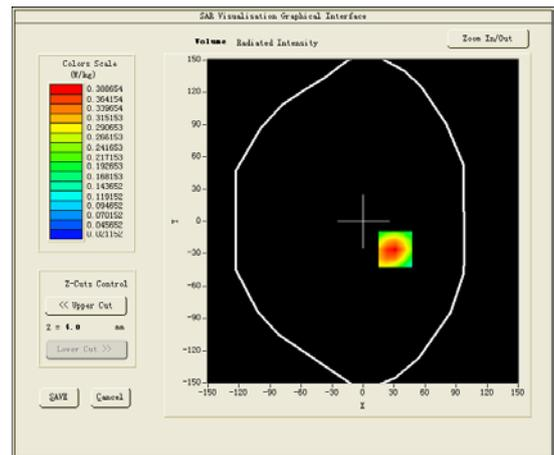
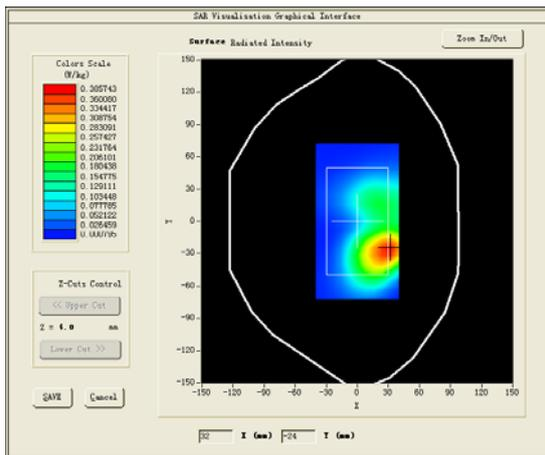

#5

Test Mode: LTE Band 2, 1RB, High Channel (Body Front Side)

Product Description: Personal GPS Tracker

Model: GK310

Test Date: October 12, 2017

Medium(liquid type)	MSL_1900
Frequency (MHz)	1900.000000
Relative permittivity (real part)	53.04
Conductivity (S/m)	1.58
E-Field Probe	SN45/15 EPGO281
Crest Factor	1.0
Conversion Factor	2.16
Sensor	4mm
Area Scan	dx=8mm dy=8mm
Zoom Scan	5x5x7,dx=8mm dy=8mm dz=5mm
Variation (%)	0.820000
SAR 10g (W/Kg)	0.409843
SAR 1g (W/Kg)	0.660436

**SURFACE SAR**

**VOLUME SAR**

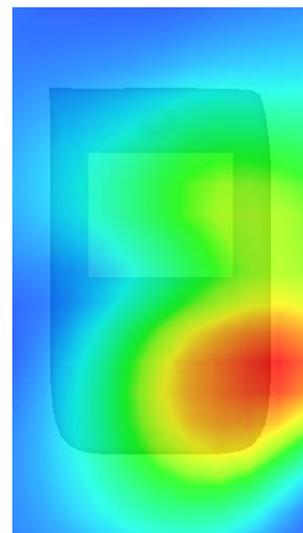
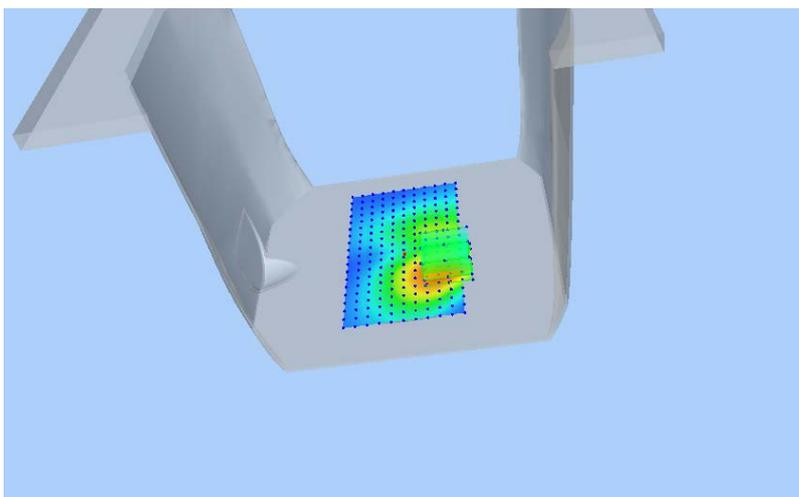
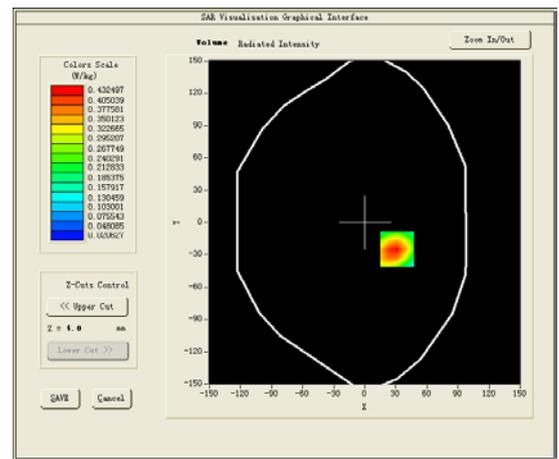
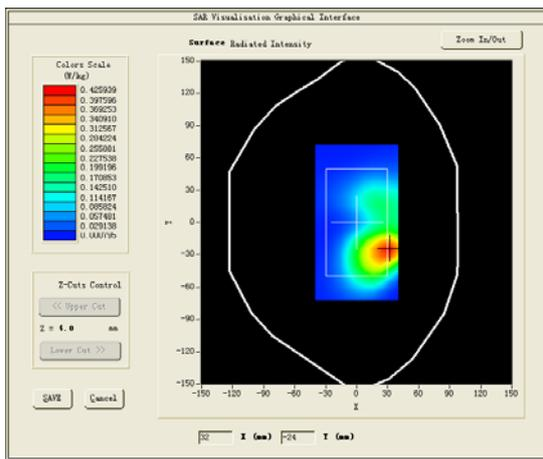



#6

Test Mode: LTE Band 4, 1RB, Low Channel (Body Front Side)

Product Description: Personal GPS Tracker

Model: GK310

Test Date: October 13, 2017

Medium(liquid type)	MSL_1800
Frequency (MHz)	1720.000000
Relative permittivity (real part)	52.64
Conductivity (S/m)	1.53
E-Field Probe	SN45/15 EPGO281
Crest Factor	1.0
Conversion Factor	1.87
Sensor	4mm
Area Scan	dx=8mm dy=8mm
Zoom Scan	5x5x7,dx=8mm dy=8mm dz=5mm
Variation (%)	0.790000
SAR 10g (W/Kg)	0.354977
SAR 1g (W/Kg)	0.774164
<b>SURFACE SAR</b>	<b>VOLUME SAR</b>

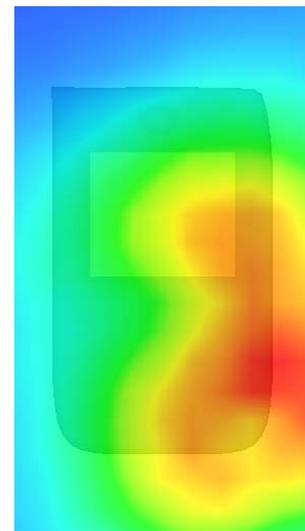
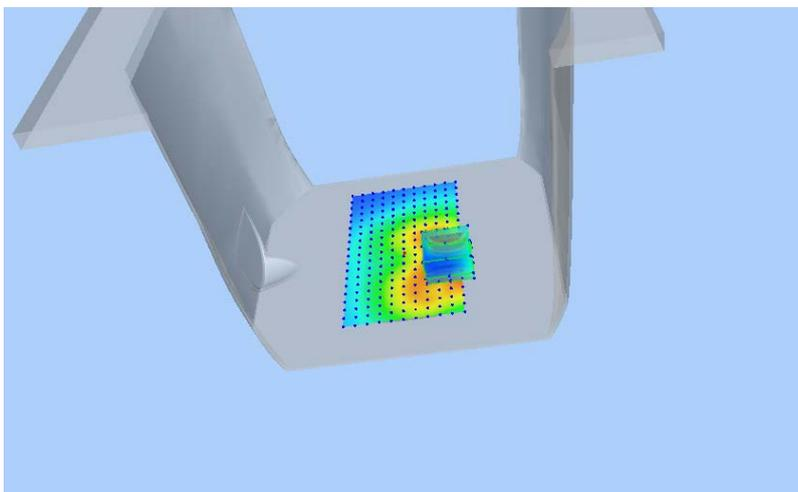
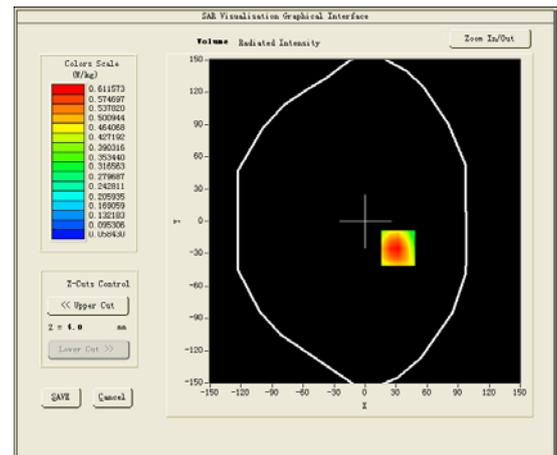
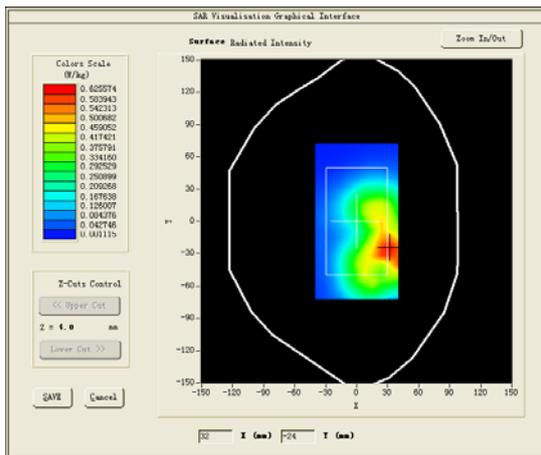

## 5. CALIBRATION CERTIFICATES

### 5.1 Probe-EPGO281 Calibration Certificate



## COMOSAR E-Field Probe Calibration Report

Ref : ACR.348.1.15.SATU.A

**SHENZHEN STS TEST SERVICES CO., LTD.**  
1/F., BUILDING B, ZHUOKE SCIENCE PARK, No.190,  
CHONGQING ROAD, FUYONG STREET  
BAO'AN DISTRICT, SHENZHEN, GUANGDONG, CHINA  
**MVG COMOSAR DOSIMETRIC E-FIELD PROBE**  
SERIAL NO.: SN 45/15 EPGO281

Calibrated at MVG US  
2105 Barrett Park Dr. - Kennesaw, GA 30144



Calibration Date: 02/04/2017

*Summary:*

This document presents the method and results from an accredited COMOSAR Dosimetric E-Field Probe calibration performed in MVG USA using the CALISAR / CALIBAIR test bench, for use with a COMOSAR system only. All calibration results are traceable to national metrology institutions.



## COMOSAR E-FIELD PROBE CALIBRATION REPORT

Ref: ACR.348.1.15.SATU.A

	<i>Name</i>	<i>Function</i>	<i>Date</i>	<i>Signature</i>
<i>Prepared by :</i>	Jérôme LUC	Product Manager	02/08/2017	<i>JL</i>
<i>Checked by :</i>	Jérôme LUC	Product Manager	02/08/2017	<i>JL</i>
<i>Approved by :</i>	Kim RUTKOWSKI	Quality Manager	02/08/2017	<i>Kim Rutkowski</i>

	<i>Customer Name</i>
<i>Distribution :</i>	Shenzhen STS Test Services Co., Ltd.

<i>Issue</i>	<i>Date</i>	<i>Modifications</i>
A	02/08/2017	Initial release

Page: 2/10

*This document shall not be reproduced, except in full or in part, without the written approval of MVG.  
The information contained herein is to be used only for the purpose for which it is submitted and is not to be released in whole or part without written approval of MVG.*



COMOSAR E-FIELD PROBE CALIBRATION REPORT

Ref: ACR.348.1.15.SATU.A

TABLE OF CONTENTS

1 Device Under Test ..... 4

2 Product Description ..... 4

    2.1 General Information ..... 4

3 Measurement Method ..... 4

    3.1 Linearity ..... 4

    3.2 Sensitivity ..... 5

    3.3 Lower Detection Limit ..... 5

    3.4 Isotropy ..... 5

    3.5 Boundary Effect ..... 5

4 Measurement Uncertainty ..... 5

5 Calibration Measurement Results ..... 6

    5.1 Sensitivity in air ..... 6

    5.2 Linearity ..... 7

    5.3 Sensitivity in liquid ..... 7

    5.4 Isotropy ..... 8

6 List of Equipment ..... 10

*This document shall not be reproduced, except in full or in part, without the written approval of MVG.  
The information contained herein is to be used only for the purpose for which it is submitted and is not to be released in whole or part without written approval of MVG.*



## COMOSAR E-FIELD PROBE CALIBRATION REPORT

Ref: ACR.348.1.15.SATU.A

**1 DEVICE UNDER TEST**

Device Under Test	
Device Type	COMOSAR DOSIMETRIC E FIELD PROBE
Manufacturer	MVG
Model	SSE2
Serial Number	SN 45/15 EPGO281
Product Condition (new / used)	New
Frequency Range of Probe	0.45 GHz-6GHz
Resistance of Three Dipoles at Connector	Dipole 1: R1=0.186 MΩ Dipole 2: R2=0.194 MΩ Dipole 3: R3=0.191 MΩ

A yearly calibration interval is recommended.

**2 PRODUCT DESCRIPTION****2.1 GENERAL INFORMATION**

MVG's COMOSAR E field Probes are built in accordance to the IEEE 1528, OET 65 Bulletin C and CEI/IEC 62209 standards.



**Figure 1** – MVG COMOSAR Dosimetric E field Dipole

Probe Length	330 mm
Length of Individual Dipoles	2 mm
Maximum external diameter	8 mm
Probe Tip External Diameter	2.5 mm
Distance between dipoles / probe extremity	1 mm

**3 MEASUREMENT METHOD**

The IEEE 1528, OET 65 Bulletin C, CENELEC EN50361 and CEI/IEC 62209 standards provide recommended practices for the probe calibrations, including the performance characteristics of interest and methods by which to assess their affect. All calibrations / measurements performed meet the fore mentioned standards.

**3.1 LINEARITY**

The evaluation of the linearity was done in free space using the waveguide, performing a power sweep to cover the SAR range 0.01W/kg to 100W/kg.

Page: 4/10

*This document shall not be reproduced, except in full or in part, without the written approval of MVG.  
The information contained herein is to be used only for the purpose for which it is submitted and is not to be released in whole or part without written approval of MVG.*



## COMOSAR E-FIELD PROBE CALIBRATION REPORT

Ref: ACR.348.1.15.SATU.A

### 3.2 SENSITIVITY

The sensitivity factors of the three dipoles were determined using a two step calibration method (air and tissue simulating liquid) using waveguides as outlined in the standards.

### 3.3 LOWER DETECTION LIMIT

The lower detection limit was assessed using the same measurement set up as used for the linearity measurement. The required lower detection limit is 10 mW/kg.

### 3.4 ISOTROPY

The axial isotropy was evaluated by exposing the probe to a reference wave from a standard dipole with the dipole mounted under the flat phantom in the test configuration suggested for system validations and checks. The probe was rotated along its main axis from 0 - 360 degrees in 15 degree steps. The hemispherical isotropy is determined by inserting the probe in a thin plastic box filled with tissue-equivalent liquid, with the plastic box illuminated with the fields from a half wave dipole. The dipole is rotated about its axis (0°–180°) in 15° increments. At each step the probe is rotated about its axis (0°–360°).

### 3.5 BOUNDARY EFFECT

The boundary effect is defined as the deviation between the SAR measured data and the expected exponential decay in the liquid when the probe is oriented normal to the interface. To evaluate this effect, the liquid filled flat phantom is exposed to fields from either a reference dipole or waveguide. With the probe normal to the phantom surface, the peak spatial average SAR is measured and compared to the analytical value at the surface.

## 4 MEASUREMENT UNCERTAINTY

The guidelines outlined in the IEEE 1528, OET 65 Bulletin C, CENELEC EN50361 and CEI/IEC 62209 standards were followed to generate the measurement uncertainty associated with an E-field probe calibration using the waveguide technique. All uncertainties listed below represent an expanded uncertainty expressed at approximately the 95% confidence level using a coverage factor of k=2, traceable to the Internationally Accepted Guides to Measurement Uncertainty.

Uncertainty analysis of the probe calibration in waveguide					
ERROR SOURCES	Uncertainty value (%)	Probability Distribution	Divisor	ci	Standard Uncertainty (%)
Incident or forward power	3.00%	Rectangular	$\sqrt{3}$	1	1.732%
Reflected power	3.00%	Rectangular	$\sqrt{3}$	1	1.732%
Liquid conductivity	5.00%	Rectangular	$\sqrt{3}$	1	2.887%
Liquid permittivity	4.00%	Rectangular	$\sqrt{3}$	1	2.309%
Field homogeneity	3.00%	Rectangular	$\sqrt{3}$	1	1.732%
Field probe positioning	5.00%	Rectangular	$\sqrt{3}$	1	2.887%

Page: 5/10

*This document shall not be reproduced, except in full or in part, without the written approval of MVG. The information contained herein is to be used only for the purpose for which it is submitted and is not to be released in whole or part without written approval of MVG.*



COMOSAR E-FIELD PROBE CALIBRATION REPORT

Ref: ACR.348.1.15.SATU.A

Field probe linearity	3.00%	Rectangular	$\sqrt{3}$	1	1.732%
<b>Combined standard uncertainty</b>					5.831%
<b>Expanded uncertainty</b> 95 % confidence level k = 2					12.0%

5 CALIBRATION MEASUREMENT RESULTS

Calibration Parameters	
Liquid Temperature	21 °C
Lab Temperature	21 °C
Lab Humidity	45 %

5.1 SENSITIVITY IN AIR

Normx dipole 1 ( $\mu\text{V}/(\text{V}/\text{m})^2$ )	Normy dipole 2 ( $\mu\text{V}/(\text{V}/\text{m})^2$ )	Normz dipole 3 ( $\mu\text{V}/(\text{V}/\text{m})^2$ )
0.77	0.83	0.67

DCP dipole 1 (mV)	DCP dipole 2 (mV)	DCP dipole 3 (mV)
91	90	95

Calibration curves  $e_i=f(V)$  ( $i=1,2,3$ ) allow to obtain H-field value using the formula:

$$E = \sqrt{E_1^2 + E_2^2 + E_3^2}$$

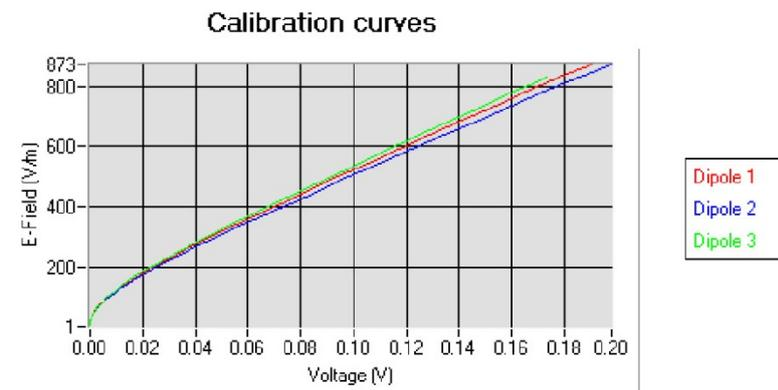

*This document shall not be reproduced, except in full or in part, without the written approval of MVG. The information contained herein is to be used only for the purpose for which it is submitted and is not to be released in whole or part without written approval of MVG.*



COMOSAR E-FIELD PROBE CALIBRATION REPORT

Ref: ACR.348.1.15.SATU.A

5.2 LINEARITY

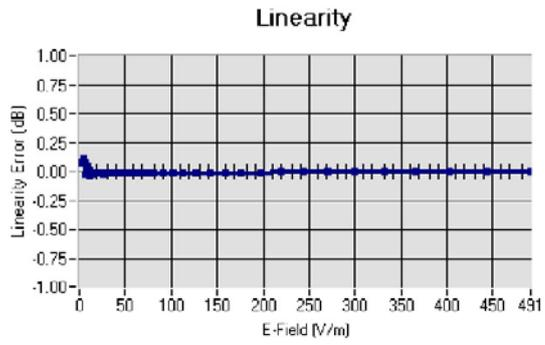

Linearity:  $\pm 2.60\%$  ( $\pm 0.11$  dB)

5.3 SENSITIVITY IN LIQUID

Liquid	Frequency (MHz +/- 100MHz)	Permittivity	Epsilon (S/m)	ConvF
HL450	450	44.12	0.88	1.76
BL450	450	58.92	1.00	1.81
HL750	750	42.24	0.90	1.53
BL750	750	56.85	0.99	1.59
HL850	835	43.02	0.90	1.78
BL850	835	53.72	0.98	1.85
HL900	900	42.47	0.99	1.62
BL900	900	56.97	1.09	1.67
HL1800	1800	42.24	1.40	1.83
BL1800	1800	53.53	1.53	1.87
HL1900	1900	40.79	1.42	2.10
BL1900	1900	54.47	1.57	2.16
HL2000	2000	40.52	1.44	2.01
BL2000	2000	54.18	1.56	2.09
HL2450	2450	38.73	1.81	2.21
BL2450	2450	53.23	1.96	2.28
HL2600	2600	38.54	1.95	2.32
BL2600	2600	52.07	2.23	2.38
HL5200	5200	36.80	4.84	2.46
BL5200	5200	51.21	5.16	2.52
HL5400	5400	36.35	4.96	2.70
BL5400	5400	50.51	5.70	2.79
HL5600	5600	35.57	5.23	2.74
BL5600	5600	49.83	5.91	2.83
HL5800	5800	35.30	5.47	2.53
BL5800	5800	49.03	6.28	2.60

LOWER DETECTION LIMIT: 9mW/kg

*This document shall not be reproduced, except in full or in part, without the written approval of MVG. The information contained herein is to be used only for the purpose for which it is submitted and is not to be released in whole or part without written approval of MVG.*





COMOSAR E-FIELD PROBE CALIBRATION REPORT

Ref: ACR.348.1.15.SATU.A

5.4 ISOTROPY

**HL900 MHz**

- Axial isotropy: 0.04 dB
- Hemispherical isotropy: 0.06 dB

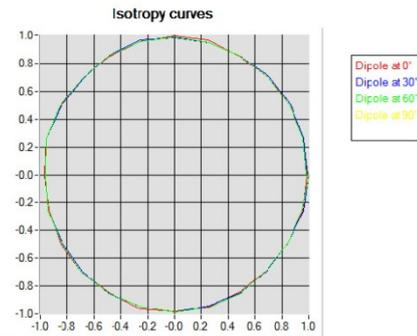

**HL1800 MHz**

- Axial isotropy: 0.04 dB
- Hemispherical isotropy: 0.08 dB

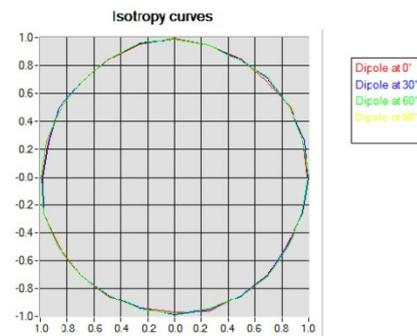

*This document shall not be reproduced, except in full or in part, without the written approval of MVG. The information contained herein is to be used only for the purpose for which it is submitted and is not to be released in whole or part without written approval of MVG.*