

Project Dräger BT Module

Version: 0.7
State: Draft

Distribution List

Name (alphabetic)	Department	Location

Copyright			
Dräger Safety AG & Co. KGaA			
Author		Verified by	
Dept.: 5420	Signature:	Dept.: 5420	Signature:
Name: Sebastian Kleiner		Name: Markus Gnade	
Phone: 1951		Phone: NA	
File: Dräger BT Module Spec.		File:	
Date: December 8, 2021		Date: NA	

State of the Document

Version	State	Date	Responsible Person	Reason for Correction
0.1	DRAFT		Sebastian Kleiner	Initial Version
0.2	DRAFT		Markus Gnade	FCC / IC ID added
0.3	DRAFT		Markus Gnade	Update FCC manual description
0.4	DRAFT		Markus Gnade	Update RED description, EU-DoC added
0.5	DRAFT		Markus Gnade	Update IC description with French warning texts
0.6	DRAFT		Markus Gnade	Update FCC and IC information for BT02 module
0.7	DRAFT		Markus Gnade	Updated EU-DoC for BT01

Persons Authorized to Change the Document

- Sebastian Kleiner
- Markus Gnade

Authoring Tools

- Microsoft Word 2003
- Microsoft Visio 2000

Table of Content

1	GENERAL	5
1.1	Motivation.....	5
1.2	Terms and Definition	5
1.3	References	5
2	9X11MM MODUL DESCRIPTION (BT01)	6
2.1	Block diagram	6
2.2	Hardware description	6
2.2.1	Electrical Specification	6
2.2.2	Receiver Sensitivity	7
2.2.3	Transmit Power	8
2.2.4	Interfaces	8
2.3	Modul Pinning 9x11mm.....	9
2.4	Footprint Part number 9x11mm.....	10
3	17X10MM MODUL DESCRIPTION	11
3.1	Block diagram	11
3.2	Hardware description	11
3.2.1	Use with Dräger adapter 8326001	11
3.2.2	Electrical Specification	12
3.2.3	Receiver Sensitivity	13
3.2.4	Transmit Power	13
3.2.5	Interfaces	13
3.3	Modul Pinning 17x10mm.....	15
3.4	Footprint Part number 17x10mm.....	16
4	SOFTWARE	17
5	MAINTENANCE ACCESS TEST MODES	18

- 5.1 Setup power supply 18**
 - 5.1.1 Setup for extern-controlled power supply 18
 - 5.1.2 Setup to use Buck/Boost converter 18

- 5.2 Test board with 9x11mm Dräger module 19**

- 5.3 Test board with 17x10mm Dräger module 19**

- 6 APPROVALS 20**
 - 6.1 Federal Communicators Commissions for US (FCC)..... 20**
 - 6.1.1 List of approved Antennas 20
 - 6.1.2 FCC ID BT01 20
 - 6.1.3 FCC ID BT02 21

 - 6.2 Innovation, Science, and Economic Development (ISED) for Canada..... 21**
 - 6.2.1 List of approved Antennas 21
 - 6.2.2 Licence ID BT01 22
 - 6.2.3 Licence ID BT02 22

 - 6.3 European Conformity According to RED (2014/53/EU) 22**

 - 6.4 Bluetooth SIG 23**

- 7 ENVIROMENTAL 24**

- 8 SOLDER PROFILE 25**

1 General

1.1 Motivation

Due to the necessities of connectivity solutions, especially Bluetooth functionality, in nearby every Draeger product in the future and the specialties of the requirements in terms of Ex- and Radio approvals, the need to provide an own customized Dräger Bluetooth module is more and more present. Typical Bluetooth modules needs to be modified by the vendors in terms of reducing capacitance and removing inductance to fulfill the ATEX, IECEx requirements. Furthermore, Radio approvals very often require detailed development and production information's, which are not easy to provide when using consumer modules.

Two different variants of the Draeger Bluetooth Module will be developed, due to be able to cover all internal project requirements. This results in a 9x11mm Module and a 17x10mm Module.

1.2 Terms and Definition

BT- Bluetooth

1.3 References

Projektverzeichnis

[1] [Nordic: nRF52840_ProductSpecification_v1.1.pdf](#)

[2] Test Mode Dräger BT Modules.pdf

2 9x11mm Modul description (BT01)

The 9x11mm Dräger BT Module variant shall be used in new Products and should be as small as possible to be able to be integrated also in small handheld Dräger devices.

Main features are:

- small size 11x9mm
- BT 5.1 functionality (long range capable, direction finding, support of mesh networks)
- easy to integrate in EX protected devices in terms of having no inductors and a reduced value of capacitance
- support of low energy applications

2.1 Block diagram

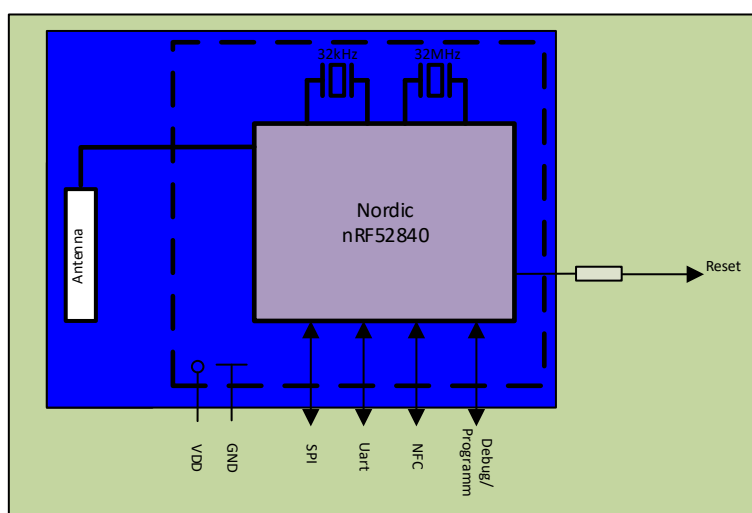

Figure 2.1-1:Block Diagramm Dräger BT Modul 9x11mm

2.2 Hardware description

The Dräger module contains mainly the nRF52840 Chipset from Nordic Semiconductor. Due to space requirements a small footprint ceramic loop antenna is used. Note that in this variant there is no option to use an external antenna. In addition to that, a low frequency crystal (32,768 kHz) is placed on the module.

2.2.1 Electrical Specification

Most of the recommended and maximum rated parameters in terms of supply voltage, operating and sleep current or interface voltage levels are defined by the use of the nRF52840 Chipset. Please refer reference [1] or visit <https://www.nordicsemi.com/Products/Low-power-short-range-wireless/nRF52840>.

The nRF52840 is connected according to circuit configuration no. 6 for CKAA WLCSP in normal voltage mode. So, the internal REG0 stage is disabled automatically and the device is powered out REG1 stage. Per default the regulator stage is working in LDO mode. The buck regulator mode can be enabled in the DCDCEN registers. Please note that for ATEX proposes no external inductors are connected. Therefore, the use of the internal buck regulator is prohibited. Please refer reference [1] section 5.3 POWER — Power supply for further details.

2.2.1.1 Normal Operation

Symbol	Description	min	nom	max	Unit
VDD	Supply voltage	1,7	3	3,6	V
VIN High	Digital interfaces input high voltage	0.7*VDD		VDD	V
VIN low	Digital interfaces input low voltage	VSS		0.3*VDD	V
Iop	Operating current	tbd	tbd	tbd	mA
I _p	Pulse current				mA
T _a	Operating Temperature Range	-40	25	85	°C
C _m	Overall capacitance	5,72	7,10	8,48	µF
L _m	Overall inductance	8,37	8,6	8,84	nH

Figure 2.2-1: operating conditions

2.2.1.2 Absolut maximum operation

Symbol	Description	min	max	Unit
VDD	Supply voltage	-0,3	3,9	V
VIN IO	Digital interfaces input voltage	-0,3	3,9	V
VSS	System Ground		0	V
I _s	Operating current	tbd	tbd	mA
I _{NFC}	Max. NFC input current		80	mA
RF _{in}	RF input level		10	dBm
ESD _{HB}	ESD human body		1	kV
T _s	Storage Temperature Range	-40	125	°C

Figure 2.2-2: Absolut maximum operating conditions

2.2.2 Receiver Sensitivity

VDD = 1,7V to 3,6V, T_{amb} = +20°C

Measured conducted according to xxx

Symbol	Description	min	nom	max	Unit
Sensitivity			tbd		

Figure 2.2-3: Receiver Sensitivity

2.2.3 Transmit Power

VDD = 1,7V to 3,6V, Tamb = +20°C

Measured conducted according to xxx

Symbol	Description	min	nom	max	Unit
			tbd		

Figure 2.2-4: Transmit Power

2.2.4 Interfaces

Supported electrical interface are SPI, I2S, UART and Software Debug Interface. All GPIOs are configurable in the PSEL registers for interface functionality. Refer [Table 2-1: Pin assignments](#) for available GPIOs.

Furthermore, an NFC Antenna can be connected, to use the nRF52840 internal NFC-A listening device.

Note: The data rate is limited to 106 kbps

2.2.4.1 Serial Wire Debug SWD

This interface provides SWDIO and SWCLK signals for debug purposes during development. Leave this pins open once they are not needed.

Please refer <https://www.nordicsemi.com/Products/Low-power-short-range-wireless/nRF52840> for further details.

Note: pull up (SWDIO) and pull down (SWCLK) are implemented in nRF52840

Symbol	Description	min	nom	max	Unit
Rpull	Internal SWDIO and SWDCLK pull up/down resistance		13		kOhm
SWCLK	Serial wire clock	0.125		8	MHz

Figure 2.2-5:electrical specification SWD interface

2.2.4.2 Serial Peripheral Interface SPI

The nRF52840 provides an SPI interface for full duplex, synchronous communication to other devices. The Dräger Modul can be used either as master or as slave. High bit rates may require GPIOs to be set as High Drive.

Please refer <https://www.nordicsemi.com/Products/Low-power-short-range-wireless/nRF52840> for further details.

Symbol	Description	min	nom	max	Unit
F_SPI	Bit rates for SPI			8	MHz

Figure 2.2-6: electrical specification SPI interface

Note: The nRF52840 provides no nCS functionality. It must be organized separately in the master as well in the slave.

2.2.4.3 Universal asynchronous receiver/transmitter UART

The nRF52840 provides an UART interface to establish a serial interface for data exchange to other devices. This interface features full duplex, automatic flow control and parity checking. Maximum baud rate is 1Mbaud. In principle every available GPIO can be used as UART interface.

Please refer <https://www.nordicsemi.com/Products/Low-power-short-range-wireless/nRF52840> for further details.

Note 1: High bit rates may require GPIOs to be set as High Drive (see GPIO chapter in nRF52840 specification)

2.3 Modul Pinning 9x11mm

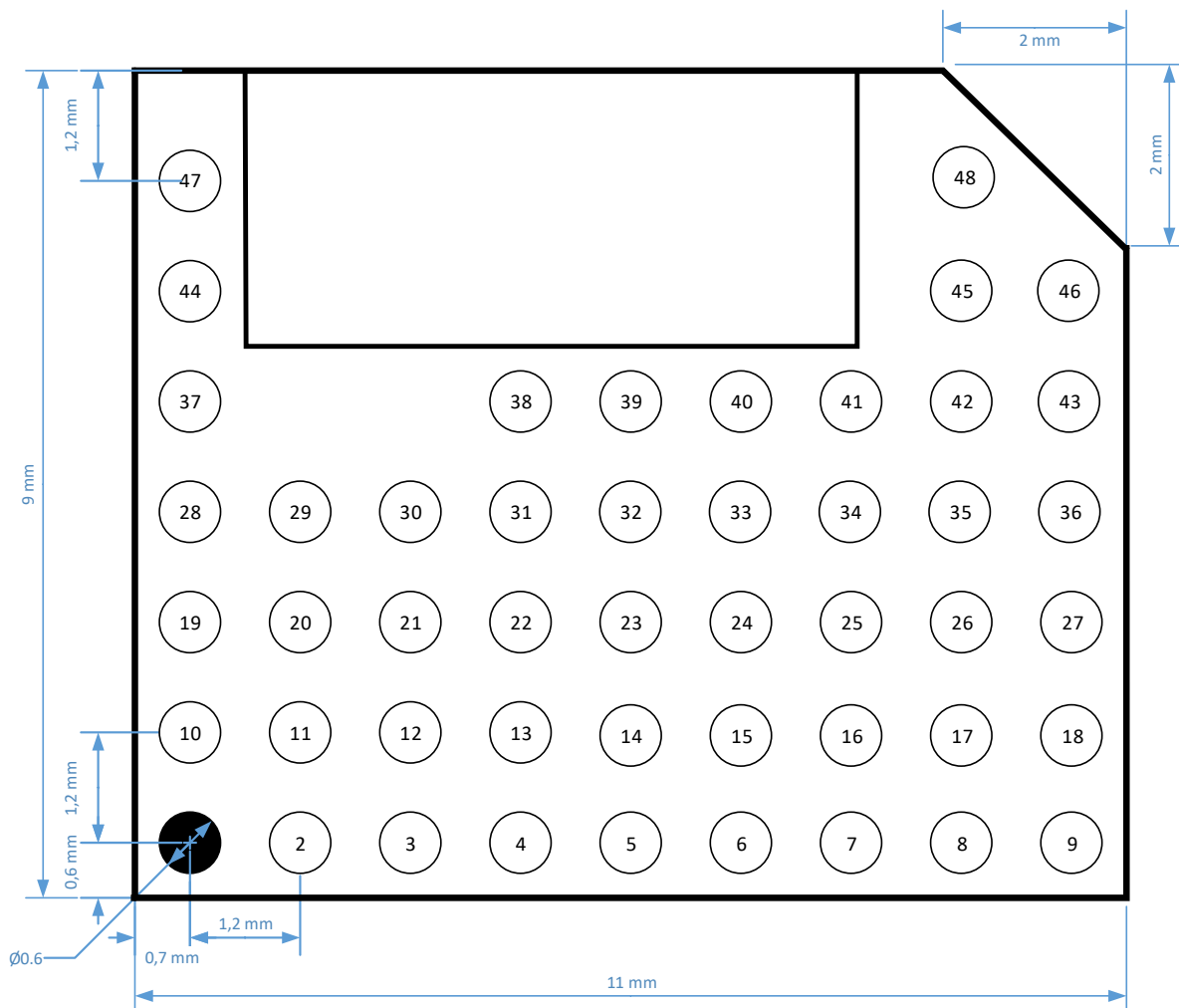

Figure 2.3-1: Modul Pinout (Top View)

Pin	Signal	Pin	Signal	Pin	Signal
1	GND	19	GND	37	GND
2	VCC	20	GND	38	GND
3	GND	21	GND	39	GND
4	SWDCLK	22	GND	40	GND
5	SWDIO	23	GND	41	GND
6	GND	24	GND	42	GND
7	P0.18/ Reset	25	P0.07/ Traceclk	43	GND
8	GND	26	P1.09/ Tracedata3	44	GND
9	GND	27	P0.12/ Tracedata1	45	GND
10	NFC1	28	GND	46	GND
11	NFC2	29	GND	47	GND
12	GND	30	GND	48	GND
13	P1.00/ Tracedata0	31	P0.03/ AIN1		
14	P0.17/ IO	32	P0.02/ AIN0		
15	P0.16/ IO	33	P0.28/ AIN4		
16	P0.14/ IO	34	P0.30/ AIN6		
17	P0.13/ IO	35	P0.05/ AIN3		
18	P0.11/ Tracedata2	36	P0.04/ AIN2		

Table 2-1: Pin assignments

2.4 Footprint Part number 9x11mm

A symbol and footprint can be found in our global Mentor Library

Part number: 3711863

Dataset: 10002160

3 17x10mm Modul description

The 17x10mm Dräger BT Module variant shall be used in existing projects as a replicant for actual used BT-Modul Telit S42. The Dräger BT Module is pin compatible to the Telit S42 but features more functionality by having four times more memory capacity and support more BT5 features.

Main features are:

- Compact size 17x10mm
- BT 5.1 functionality
- easy to integrate in EX protected devices in terms of having no inductors and a reduced value of capacitance
- support of low energy applications
- additional antenna connector for optional external antennas

3.1 Block diagram

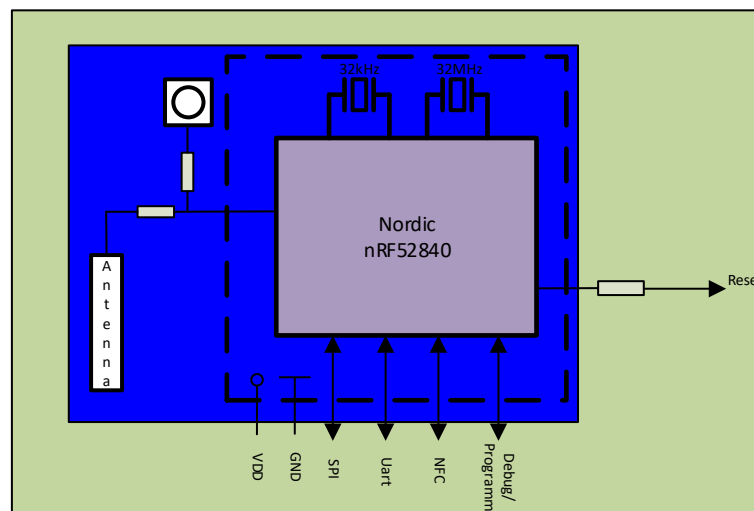

Figure 3.1-1:Block Diagramm Dräger BT Modul 17x10mm

3.2 Hardware description

The Dräger module contains mainly the nRF52840 Chipset from Nordic Semiconductor. Due to space requirements a small footprint ceramic loop antenna is used. An option to use an external antenna is implemented. In addition to that, a low frequency crystal (32,768 kHz) is placed on the module.

3.2.1 Use with Dräger adapter 8326001

The 17x10mm Modul can be used directly on the PCB or with the Dräger Adapter 8326001. This adapter provides Test points which might be useful for maintenance or debug purposes. However, table below shows the signals matched to the existing Test points.

Pin BT-Modul	Pin nrF52840	Signal	TP Adapter 8326001
5	P1.00	TD0	25
42	P0.12	TD1	20
17	P0.11	TD2	13
10	P1.09	TD3	19
28	P0.07	TCLK	17
9	P0.26	Boot	9
1	P0.08	Testmode	3
18	P0.14	RXD	27
4	P0.13	TXD	5
3	P0.17	CTS	15
23	P0.16	RTS	6
21	P0.02	IRUIN	16

Table 3-1 Pins matched to Adapter 8326001 Test Points

3.2.2 Electrical Specification

Most of the recommended and maximum rated parameters in terms of supply voltage, operating and sleep current or interface voltage levels are defined by the use of the nRF52840 Chipset. Please refer reference [1] or visit <https://www.nordicsemi.com/Products/Low-power-short-range-wireless/nRF52840>.

The nRF52840 is connected according to circuit configuration no. 6 for CKAA WLCSP in normal voltage mode. So, the internal REG0 stage is disabled automatically and the device is powered out REG1 stage. Per default the regulator stage is working in LDO mode. The buck regulator mode can be enabled in the DCCDCEN registers. Please note that for ATEX proposes no external inductors are connected. Therefore, the use of the internal buck regulator is prohibited. Please refer reference [1] section 5.3 POWER — Power supply for further details.

3.2.2.1 Normal Operation

Symbol	Description	min	nom	max	Unit
VDD	Supply voltage	1,7	3	3,6	V
VIN High	Digital interfaces input high voltage	0.7*VDD		VDD	V
VIN low	Digital interfaces input low voltage	VSS		0.3*VDD	V
Iop	Operating current	tbd	tbd	tbd	mA
Ip	Pulse current				mA
Ta	Operating Temperature Range	-40	25	85	°C
Cm	Overall capacitance	5,72	7,10	8,48	µF
Lm	Overall inductance	8,37	8,6	8,84	nH

Figure 3.2-1: operating conditions

3.2.2.2 Absolut maximum operation

Symbol	Description	min	max	Unit
VDD	Supply voltage	-0,3	3,9	V
VIN IO	Digital interfaces input voltage	-0,3	3,9	V
VSS	System Ground		0	V
Is	Operating current		tbd	mA
I_NFC	Max. NFC input current		80	mA
RF_in	RF input level		10	dBm
ESD_HB	ESD human body		1	kV
Ts	Storage Temperature Range	-40	125	°C

Figure 3.2-2: Absolut maximum operating conditions

3.2.3 Receiver Sensitivity

VDD = 1,7V to 3,6V, Tamb = +20°C

Measured conducted according to xxx

Symbol	Description	min	nom	max	Unit
Sensitivity			tbd		

Figure 3.2-3: Receiver Sensitivity

3.2.4 Transmit Power

VDD = 1,7V to 3,6V, Tamb = +20°C

Measured conducted according to xxx

Symbol	Description	min	nom	max	Unit
			tbd		

Figure 3.2-4: Transmit Power

3.2.5 Interfaces

Supported electrical interface are SPI, I2S, UART and Software Debug Interface. All GPIOs are configurable in the PSEL registers for interface functionality. Refer [Table 2-1: Pin assignments](#) for available GPIOs.

Furthermore, an NFC Antenna can be connected, to use the nRF52840 internal NFC-A listening device.

Note: The data rate is limited to 106 kbps

3.2.5.1 Serial Wire Debug SWD

This interface provides SWDIO and SWCLK signals for debug purposes during development. Leave these pins open once they are not needed.

Please refer <https://www.nordicsemi.com/Products/Low-power-short-range-wireless/nRF52840> for further details.

Note: pull up (SWDIO) and pull down (SWCLK) are implemented in nRF52840

Symbol	Description	min	nom	max	Unit
Rpull	Internal SWDIO and SWCLK pull up/down resistance		13		kOhm
SWCLK	Serial wire clock	0.125		8	MHz

Figure 3.2-5: electrical specification SWD interface

3.2.5.2 Serial Peripheral Interface SPI

The nRF52840 provides an SPI interface for full duplex, synchronous communication to other devices. The Dräger Modul can be used either as master or as slave. High bit rates may require GPIOs to be set as High Drive.

Please refer <https://www.nordicsemi.com/Products/Low-power-short-range-wireless/nRF52840> for further details.

Symbol	Description	min	nom	max	Unit
F_SPI	Bit rates for SPI			8	MHz

Figure 3.2-6: electrical specification SPI interface

Note: The nRF52840 provides no nCS functionality. It must be organized separately in the master as well in the slave.

3.2.5.3 Universal asynchronous receiver/transmitter UART

The nRF52840 provides an UART interface to establish a serial interface for data exchange to other devices. This interface features full duplex, automatic flow control and parity checking. Maximum baud rate is 1Mbaud. In principle every available GPIO can be used as UART interface.

Please refer <https://www.nordicsemi.com/Products/Low-power-short-range-wireless/nRF52840> for further details.

Note 1: High bit rates may require GPIOs to be set as High Drive (see GPIO chapter in nRF52840 specification)

3.3 Modul Pinning 17x10mm

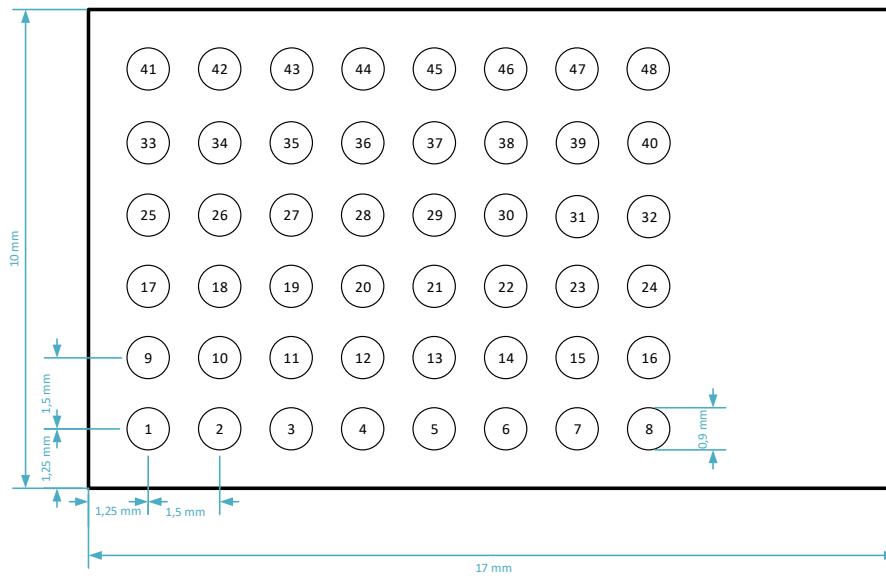

Figure 3.3-1: Modul Pinout (Top View) 17x10mm

Pin	Signal	Pin	Signal
1	P0.08 / IO	25	P0.06 / IO
2	P0.05/AIN3	26	P0.15 / IO
3	P0.17/ IO	27	P0.28 /AIN4
4	P0.13/ IO	28	P0.07/ TCLK
5	P1.00 /TD0	29	GND
6	VCC	30	GND
7	GND	31	GND
8	GND	32	GND
9	P0.26/ IO	33	P0.18/ nRES
10	P1.09/ TD3	34	P0.31 /AIN7
11	SWDIO	35	P0.20 / IO
12	P0.29/ AIN5	36	P0.04 /AIN2
13	P0.03 /AIN1	37	GND
14	VCC	38	GND
15	GND	39	GND
16	GND	40	GND
17	P0.11/ TD2	41	P0.22 / IO
18	P0.14 / IO	42	P0.12/ TD1
19	P0.27 / IO	43	NFCANT1
20	P0.30 /AIN6	44	NFCANT2
21	P0.02/ AIN0	45	P0.25/ IO
22	SWCLK	46	P0.21 / IO
23	P0.16/ IO	47	GND
24	GND	48	NC

Table 3-2: Pin assignments 17x10mm

3.4 Footprint Part number 17x10mm

A symbol and footprint can be found in our global Mentor Library

Part number: 3709318

Dataset: 10000560

4 Software

Both modules are based on the same Nordic SoC nrF52840. So, in principle, existing Firmware for this SoC is able to run on both modules. The Dräger Firmware is based on Zephyr Operation System.

Please refer to [2] for detailed Test mode description.

5 Maintenance Access Test modes

Both Dräger Moduls can be tested with the Dräger Test board part number 3713475. Either the 17x10mm or the 9x11mm variant is placeable on this Test board. All available Pins are connected to Test points. The Dräger BT Modules can be supplied either with an external controlled power supply or with an equipped DC/DC Boost Buck converter powered with batteries for example. Please refer to dataset 10002090 for further information.

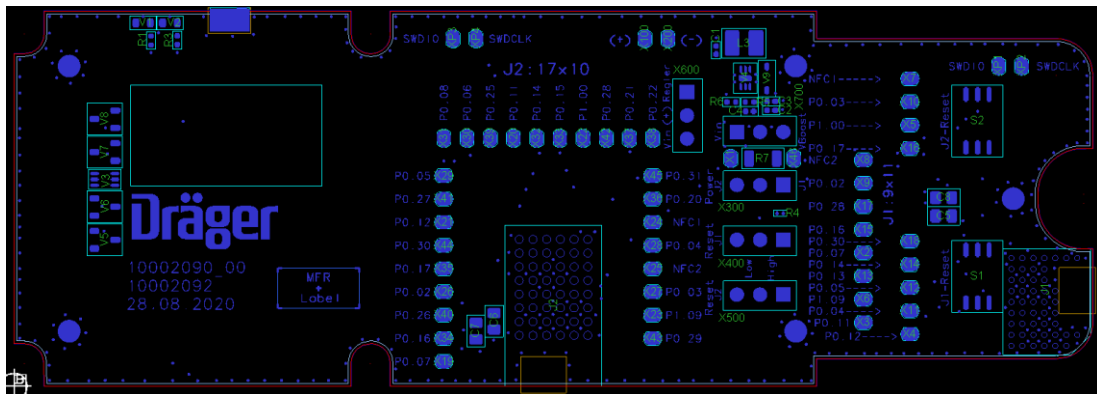

Figure 3.4-1: Dräger Test Board 3713475

Both Modules use separate software interfaces for programming. The 17x10mm relates to Test Points XP3(SWDIO) and XP4(SWDCLK) and the 9x11mm module use the Tests Points XP1(SWDIO) and XP2(SWDCLK). The Solder Pads X100 and X200 should be used to connect the Voltage source. The estimated maximum current is 50mA. The Reset Switches S1 and S2 are just placeholders and so should not be described here.

The LED V1 indicates, that the Modules are supplied with their VCC voltage. The LED V2 could be used for debug purposes by programming a GPIO from the connected module.

5.1 Setup power supply

To Setup the supply voltage for the connected modules, X600 and X700 shall be set in the right position.

5.1.1 Setup for extern-controlled power supply

- ➔ Set X600 and X700 to Vin.

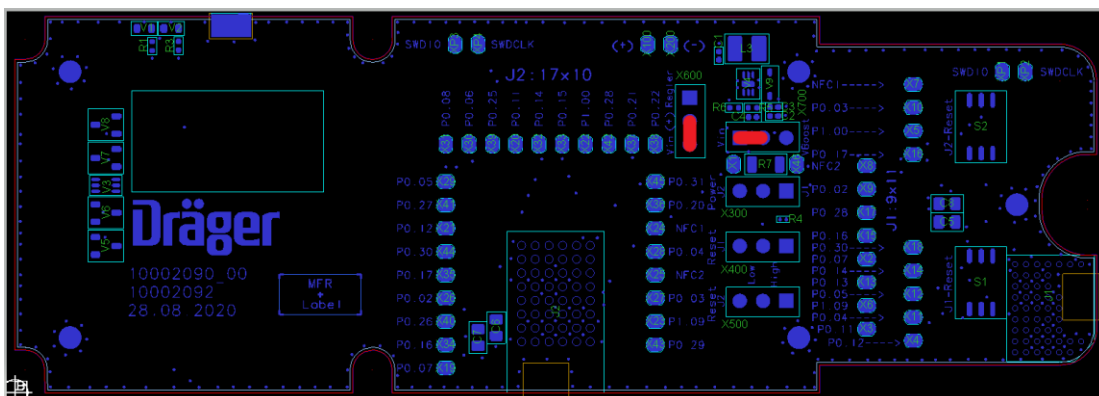

Figure 5.1-1 Test board configured for external supply

5.1.2 Setup to use Buck/Boost converter

- ➔ Set X600 to “Regler” and X700 to “VBoost”.

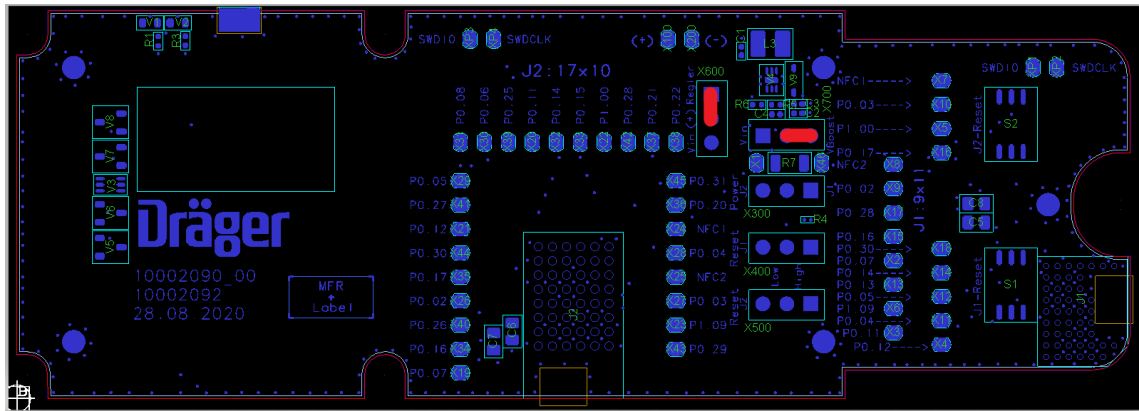

Figure 5.1-2 Test board configured to use Buck/Boost converter

5.2 Test board with 9x11mm Dräger module

To setup the Test board to the 9x11mm X300 should be set to J1.

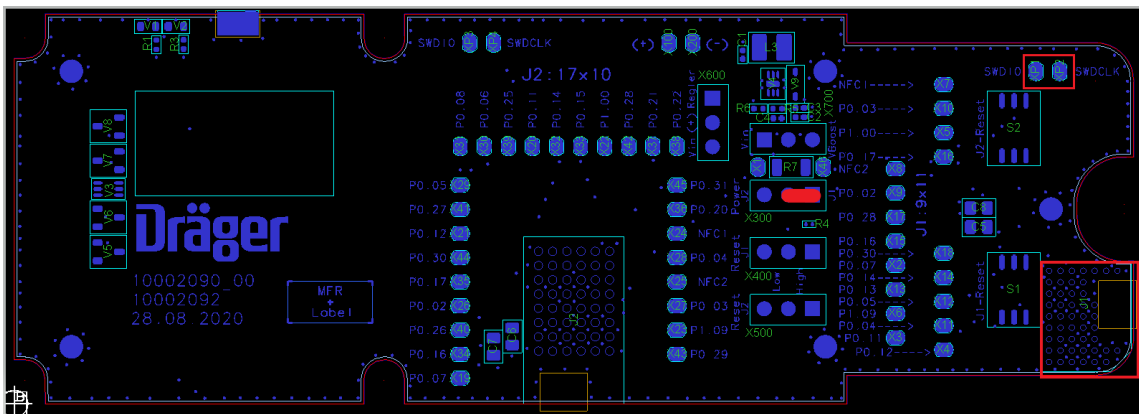

Figure 5.2-1 Test board for use with 9x11mm

5.3 Test board with 17x10mm Dräger module

To setup the Test board to the 17x10mm X300 should be set to J2

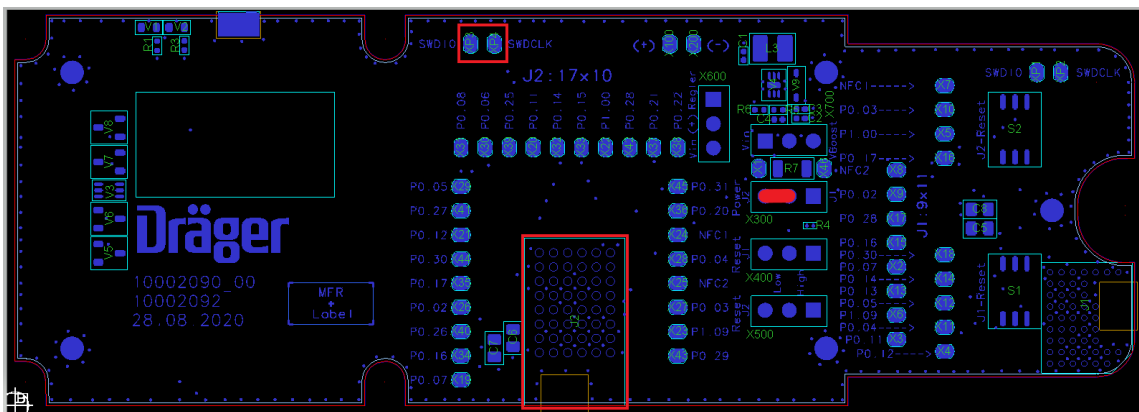

Figure 5.3-1: Test board for use with 17x10

6 Approvals

6.1 Federal Communicators Commissions for US (FCC)

The Modules with the equipped antennas comply to the requirements of Claas 2 digital devices of part 15 of the FCC rules.

The Transmitter is subjected to the following conditions:

1. This device may not cause harmful interference, and
2. This device must accept any interference received, including interference that may cause undesired operation.

The module is not for sale and the user manual integration instructions are internal confidential manufacturing documents.

6.1.1 List of approved Antennas

Manufacturer	Part-Number	Type	Frequency Band	max. Gain (dBi)
TDK	ANT016008LCS2442MA1	Chip Antenna	2,4 Ghz	-2dBi

Table 6-1: List of approved Antennas

6.1.2 FCC ID BT01

The 9x11mm BT01 module has been tested to fulfill the FCC requirements.

Model Name: BT01

FCC ID: X6O-BT01

Due to the Module size, the FCC identifier is displayed in the specification and must also be displayed in the instruction manual of the device. It cannot be displayed readable on the module's label due to the limited size

- The following information must be indicated on the host device of this module

Contains Transmitter Module FCC ID: X6O-BT01

or

Contains FCC ID: X6O-BT01

This device complies with part 15 of the FCC Rules. Operation is subject to the following two conditions: (1) This device may not cause harmful interference, and (2) this device must accept any interference received, including interference that may cause undesired operation.

When installing it in a mobile equipment.

This equipment complies with FCC radiation exposure limits set forth for an uncontrolled environment and meets the FCC radio frequency (RF) Exposure Guidelines. This equipment should be installed and operated keeping the radiator at least 20cm or more away from person's body.

When installing it in a portable equipment.

It is necessary to take a SAR test with your set mounting this module.

Class II permissive change application is necessary using the SAR report.

6.1.3 FCC ID BT02

The 17x10mm BT02 module has been tested to fulfill the FCC requirements.

Model Name: BT02

FCC ID: X6O-BT02

Due to the Module size, the FCC identifier is displayed in the specification and must also be displayed in the instruction manual of the device. It cannot be displayed readable on the module's label due to the limited size

- The following information must be indicated on the host device of this module

Contains Transmitter Module FCC ID: X6O-BT02

or

Contains FCC ID: X6O-BT02

This device complies with part 15 of the FCC Rules. Operation is subject to the following two conditions: (1) This device may not cause harmful interference, and (2) this device must accept any interference received, including interference that may cause undesired operation.

When installing it in a mobile equipment.

This equipment complies with FCC radiation exposure limits set forth for an uncontrolled environment and meets the FCC radio frequency (RF) Exposure Guidelines. This equipment should be installed and operated keeping the radiator at least 20cm or more away from person's body.

When installing it in a portable equipment.

It is necessary to take a SAR test with your set mounting this module.

Class II permissive change application is necessary using the SAR report.

6.2 Innovation, Science, and Economic Development (ISED) for Canada

The Module is licensed to meet the regulatory requirements of ISED.

This device contains licence-exempt transmitter(s)/receiver(s) that comply with Innovation, Science and Economic Development Canada's licence-exempt RSS(s). Operation is subject to the following two conditions:

1. This device may not cause interference.
2. This device must accept any interference, including interference that may cause undesired operation of the device.

L'émetteur/récepteur exempt de licence contenu dans le présent appareil est conforme aux CNR d'Innovation, Sciences et Développement économique Canada applicables aux appareils radio exempts de licence. L'exploitation est autorisée aux deux conditions suivantes :

1. L'appareil ne doit pas produire de brouillage;
2. L'appareil doit accepter tout brouillage radioélectrique subi, même si le brouillage est susceptible d'en compromettre le fonctionnement.

6.2.1 List of approved Antennas

Manufacturer	Part-Number	Type	Frequency Band	max. Gain (dBi)
TDK	ANT016008LCS2442MA1	Chip Antenna	2,4 Ghz	-2dBi

Table 6-2: List of approved Antennas

6.2.2 Licence ID BT01

BT01

Licence ID: IC: 5895F-BT01

Due to the Module size, the identifier is displayed in the specification and must also be displayed in the instruction manual of the device. It cannot be displayed readable on the module's label due to the limited size

6.2.3 Licence ID BT02

BT02

Licence ID: IC: 5895F-BT02

Due to the Module size, the identifier is displayed in the specification and must also be displayed in the instruction manual of the device. It cannot be displayed readable on the module's label due to the limited size

6.3 European Conformity According to RED (2014/53/EU)

The Dräger modules described in this Product Specification comply with the standards according to the RED (2014/53/EU) articles:

The maximum output power is +10 dBm within a frequency range of 2.402 MHz to 2480MHz.



EU-Konformitätserklärung
EU-Declaration of Conformity

Dokument Nr. / Document No. 11150230-00

Wir / we Dräger Safety AG & Co. KGaA, Revalstraße 1, 23560 Lübeck, Germany

erklären in alleiniger Verantwortung, dass das Produkt
declare under our sole responsibility that the product

Dräger Bluetooth Modul 9x11 (BT01)
Draeger Bluetooth module 9x11 (BT01)

mit der EU-Baumusterprüfbescheinigung / Expertise
is in conformity with the EU-Type Examination Certificate / **202140601/AA/00**
Expertise

ausgestellt von der notifizierten
Stelle mit der Kenn-Nr.
issued by the Notified Body
with Identification No.

Teliefication B.V.
Wilmersdorf 50
7327 AC Apeldoorn
The Netherlands
0063

und mit den folgenden Richtlinien unter Anwendung der aufgeführten Normen übereinstimmt
and is in compliance with the following directives by application of the listed standards

Bestimmungen der Richtlinie <i>provisions of directive</i>		Nummer sowie Ausgabedatum der Norm <i>Number and date of issue of standard</i>
2014/53/EU	RED-Richtlinie <i>RE Directive</i>	EN 62479:2010, EN 301 489-1 V2.2.3, EN 301 489-17 V3.2.4 EN 300 328 V2.2.2, EN 62368-1:2014
2011/65/EU 2015/863/EU	RoHS-Richtlinie <i>RoHS Directive</i>	EN IEC 63000:2018

Lübeck, 2021-12-06

Ort und Datum (jjjj-mm-tt)
Place and date (yyyy-mm-dd)



Dr. Marcus Romba
Head of Electronic Engineering
Head of Product Qualification
R&D Safety



Figure 6.3-2 - Eu-DoC for Dräger Bluetooth Module 9x11mm BT01



EU-Konformitätserklärung
EU-Declaration of Conformity

Dokument Nr. / Document No. **XXXXX-00**



Wir / we Dräger Safety AG & Co. KGaA, Revalstraße 1, 23560 Lübeck, Germany

erklären in alleiniger Verantwortung, dass das Produkt
declare under our sole responsibility that the product

Bluetooth Modul (BT02)
Bluetooth module (BT02)

mit der EU-Baumusterprüfbescheinigung / Expertise
is in conformity with the EU-Type Examination Certificate / Expertise **TBD**

ausgestellt von der notifizierten Stelle mit der Kenn-Nr. **Telefication B.V.**
issued by the Notified Body with Identification No. **Wilmersdorf 50**
7327 AC Apeldoorn
The Netherlands
0063

und mit den folgenden Richtlinien unter Anwendung der aufgeführten Normen übereinstimmt
and is in compliance with the following directives by application of the listed standards

Bestimmungen der Richtlinie <i>provisions of directive</i>		Nummer sowie Ausgabedatum der Norm <i>Number and date of issue of standard</i>
2014/53/EU	RED-Richtlinie <i>RE Directive</i>	EN 62479:2010, EN 301 489-1 V2.2.3, EN 301 489-17 V3.2.4 EN 300 328 V2.2.2, EN 62368-1:2014
2011/65/EU 2015/863/EU	RoHS-Richtlinie <i>RoHS Directive</i>	EN IEC 63000:2018

Lübeck, 2021-MM-DD

Ort und Datum (jjjj-mm-tt)
Place and date (yyyy-mm-dd)

Dc. Marcus Romba
Head of Electronic Engineering
Head of Product Qualification
R&D Safety

Figure 6.3-3 - Eu-DoC for Dräger Bluetooth Module 17x10mm BT02

6.4 Bluetooth SIG

According to the Bluetooth SIG, Modules 9x11mm and 17x10mm fulfills the criteria to label your product as a Bluetooth device.

Bluetooth 5	Declaration ID	QDID
Module 9x11	tbd	tbd
Module 17x10	tbd	tbd

Table 6-3: Bluetooth SIG qualification

7 Environmental

Following test were done with the modules.

Each test should be start, after the DUT was exposed to room temperature and humidity for at least one hour.

Item	Test	Limit	Condition
1	Heat-Shock/Temperature Cycling Test	electrical parameters should be within the specification	At -40°C and 85°C for 1h/cycle Total 100 cycle
2	Temperature Humidity Storage		At 60°C 85%r.H.,100h
3	Low Temperatur Storage		At -40°C, 100h
4	High Temperature Storage		At 85°C, 100h
5			

Table 7-1: Reliability Tests

8 Solder profile

The maximum temperature should not be more than 250°C. Further. The Temperature above 220°C should be present for at least 20 seconds but not more than 50 seconds

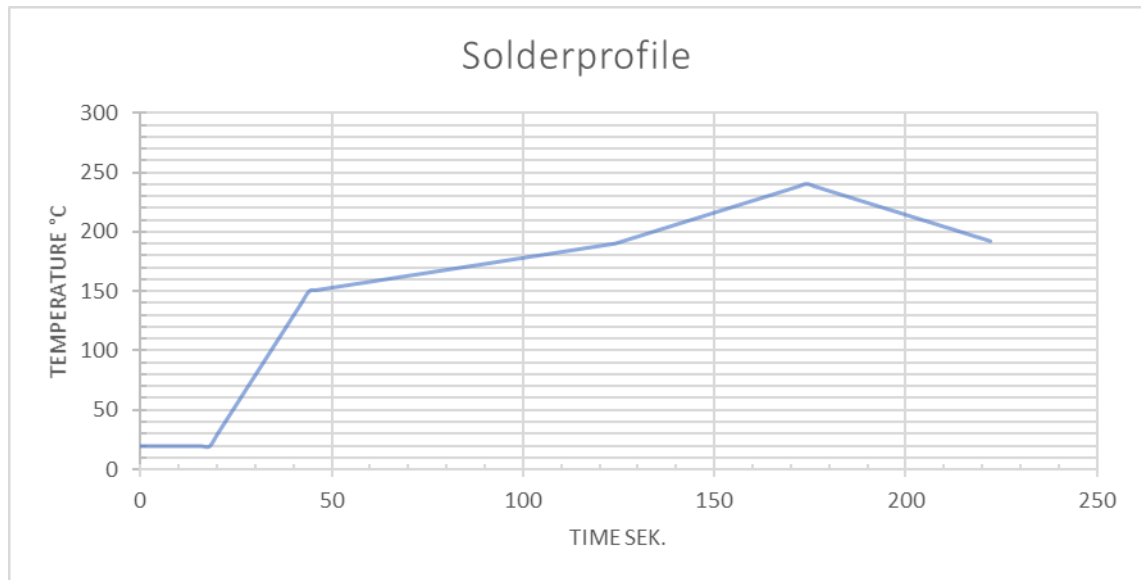

Table 8-1: Solderprofile