

FCC CFR47 PART 15 SUBPART C
CERTIFICATION
TEST REPORT

FOR

Man & Machine Inc.

2.4G Wireless Mouse

Model No.: MMOUSE/BT/B1, MMOUSE/BT/G1

FCC ID: X5DBTM1A

Prepared for : Man & Machine Inc.
Address : 3706 West Street, Landover, MD 20785, USA
Tel: +1-301-341-4900
Fax: +1-301-341-4078

Prepared by : SHENZHEN LCS CERTIFICATION SERVICES INC.
Address : 4F., No. 120, Xijing Industrial Zone, Gushutangxi, Bao'an
Road, Xixiang Town, Bao'an District, Shenzhen, China
Tel: +86-755-82591330
Fax: +86-755-82591332

Report Number : LCS100111014F
Date of Test : January 11, 2010–February 3, 2010
Date of Report : February 3, 2010

TABLE OF CONTENTS

Description	Page
1. SUMMARY OF STANDARDS AND RESULTS	3
2. GENERAL INFORMATION	4
2.1 Description of Device (EUT).....	4
2.3 Test Facility	4
2.3 Measurement Uncertainty.....	4
3. TEST METHODOLOGY	5
3.1 EUT Configuration	5
3.2 EUT Exercise.....	5
3.3 General Test Procedures	5
3.4 Description Of Test Modes.....	5
4. CONNECTION DIAGRAM OF TEST SYSTEM.....	6
5. FCC PART 15.247 REQUIREMENTS.....	7
5.1 Peak Power	7
5.2 Band Edges Measurement	8
5.3 Frequency Separation	12
5.4 Number Of Hopping Frequency	16
5.5 Time Of Occupancy (Dwell Time).....	18
5.6 Spurious Emissions.....	21
6. RADIATED EMISSION MEASUREMENT	25
6.1 Test Equipment.....	25
6.2 Block Diagram of Test Setup.....	25
6.3 Radiated Emission Limit	26
6.4 Test Results.....	26
7. POWER LINE CONDUCTED EMISSIONS.....	29
7.1 Test Equipment.....	29
7.2 Block Diagram of Test Setup.....	29
7.3 Conducted Emission Limit	29
7.4 Test Results.....	29
8. ANTENNA REQUIREMENT	31
8.1 Standard Applicable.....	31
8.2 Antenna Connected Construction	31
9. RADIO FREQUENCY EXPOSURE	32
9.1 Limit	32
9.2 EUT Specification	32
9.3 Test Results.....	32

1. SUMMARY OF STANDARDS AND RESULTS

Applicant	Man & Machine Inc. 3706 West Street, Landover, MD 20785, USA
Manufacturer	Man & Machine Inc. 3706 West Street, Landover, MD 20785, USA
EUT	2.4G Wireless Mouse
Model No.	MMOUSE/BT/B1, MMOUSE/BT/G1
Serial No.	N/A
Power Supply	DC 5V
Date of Test	January 11, 2010–February 3, 2010

APPLICABLE STANDARDS	
STANDARD	TEST RESULT
FCC 47 CFR Part 15 Subpart C	No non-compliance noted

The measurement results are contained in this test report and SHENZHEN EMTEK CO., LTD. Is assumed full responsibility for the accuracy and completeness of these measurements. Also, this report shows that the Equipment Under Test (EUT) is to be technically compliant with the FCC requirements.

This report applies to above tested sample only. This report shall not be reproduced in part without written approval of SHENZHEN LCS CERTIFICATION SERVICES INC.

Date of Test: January 11, 2010–February 3, 2010

Prepared by:

Kelda Dai

(Engineer)

Reviewed by:

Jason

(Quality Manager)

2. GENERAL INFORMATION

2.1 Description of Device (EUT)

EUT	2.4G Wireless Mouse
Model Number	MMOUSE/BT/B1, MMOUSE/BT/G1 (Note: All models are similar expect their appearance, We prepared MMOUSE/BT/G1 for test.)
Power Supply	DC 5V
Frequency Range	2402 ~ 2480 MHz
Transmit Power	1.92dBm
Modulation Technique	FHSS
Transmit Data Rate	GFSK(1Mbps), $\pi/4$ -DQPSK(2Mbps), 8-DPSK(3Mbps)
Number of Channels	79 Channels
Antenna Gain	1.5 dBi

2.2 Test Facility

Site Description

EMC Lab.

: Accredited by CNAS, 2005.11.02

The certificate is valid until 2010.11

The Laboratory has been assessed and proved to be in compliance with CNAS-CL01: 2006(identical to ISO/IEC17025:2005)

The Certificate Registration Number is L2291.

Accredited by TUV Rheinland Shenzhen, 2008.3 The

Laboratory has been assessed according to the requirements ISO/IEC 17025

Accredited by FCC, March 18, 2008 The Certificate

Registration Number is 709623.

Accredited by Industry Canada, May 24, 2008 The Certificate

Registration Number is 46405-4480.

Name of Firm

: SHENZHEN EMTEK CO., LTD

Site Location

: Bldg 69, Majialong Industry Zone, Nanshan District, Shenzhen, Guangdong, China

2.3. Measurement Uncertainty

Radiation Uncertainty (30M~1GHz) : Ur = ± 4.26 dB

Radiation Uncertainty (1G~3GHz) : Ur = ± 2.66 dB

Radiation Uncertainty (3G~18GHz) : Ur = ± 2.83 dB

Conduction Uncertainty : Uc = ± 2.61 dB

3. TEST METHODOLOGY

The tests documented in this report were performed in accordance with ANSI C63.4 and FCC CFR 47 2.1046, 2.1047, 2.1049, 2.1051, 2.1053, 2.1055, 2.1057, 15.207, 15.209 and 15.247.

3.1 EUT Configuration

The EUT configuration for testing is installed on RF field strength measurement to meet the Commissions requirement and operating in a manner that intends to maximize its emission characteristics in a continuous normal application.

3.2 EUT Exercise

The EUT was operated in the engineering mode to fix the TX frequency that was for the purpose of the measurements.

According to its specifications, the EUT must comply with the requirements of the Section 15.207, 15.209 and 15.247 under the FCC Rules Part 15 Subpart C.

3.3 General Test Procedures

3.3.1 Conducted Emissions

The EUT is placed on the turntable, which is 0.8 m above ground plane. According to the requirements in Section 13.1.4.1 of ANSI C63.4 Conducted emissions from the EUT measured in the frequency range between 0.15 MHz and 30MHz using Quasi-peak and average detector modes.

3.3.2 Radiated Emissions

The EUT is placed on a turn table, which is 0.8 m above ground plane. The turntable shall rotate 360 degrees to determine the position of maximum emission level. EUT is set 3m away from the receiving antenna, which varied from 1m to 4m to find out the highest emission. And also, each emission was to be maximized by changing the polarization of receiving antenna both horizontal and vertical. In order to find out the maximum emissions, exploratory radiated emission measurements were made according to the requirements in Section 13.1.4.1 of ANSI C63.4

3.4 Description Of Test Modes

The EUT has been tested under operating condition.

After verification, all tests were carried out with the worst case test modes as shown below except radiated spurious emission below 1GHz, which worst case was in normal link mode only.

Then, the worst case is GFSK(1M) Channel Low (2402MHz), Mid (2441MHz) and High (2480MHz), these were chosen for full testing.

Note: After the preliminary san GFSK, $\pi/4$ -DQPSK, 8-DPSK. we found the modulation at GFSK producing the highest emission level, so evaluated we chosen the above modes (worst case) as a representative.

4. CONNECTION DIAGRAM OF TEST SYSTEM

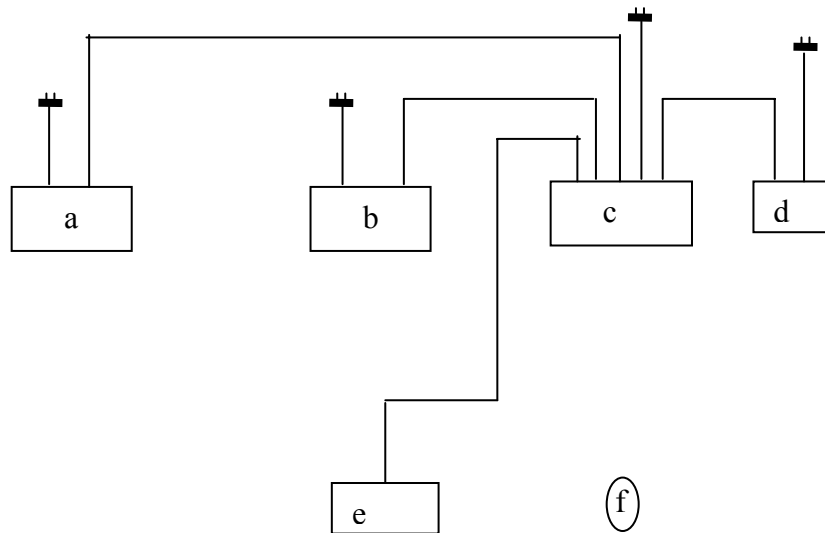

- a. Printer
- b. LCD
- c. PC
- d. Modem
- e. Keyboard
- f. EUT

5. FCC PART 15.247 REQUIREMENTS

5.1 Peak Power

5.1.1 Test Equipment

Equipment	Manufacturer	Model No.	Serial No.	Last Cal.	Cal. Interval
Spectrum Analyzer	Agilent	E4407B	MY41440292	May 29, 2009	1 Year
RF Cable	Hubersuhne	Sucoflex104	FP2RX2	May 29, 2009	1 Year
Power Sensor	Agilent	E9327A	US40441788	May 29, 2009	1 Year
Power Meter	Agilent	E4416A	QB41292714	May 29, 2009	1 Year
DC Filter	MPE	23872C	N/A	May 29, 2009	1 Year

5.1.2 Block Diagram of Test Setup

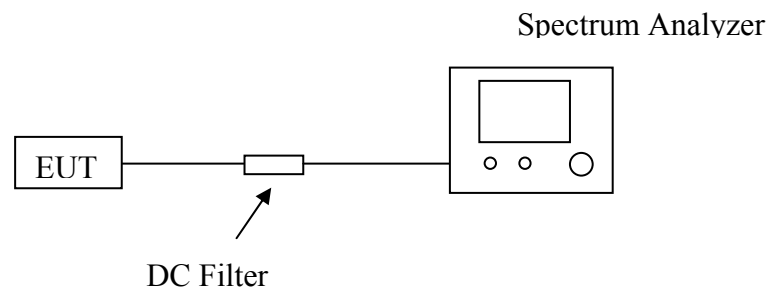

5.1.3 Limit

According to §15.247(a)(1), Frequency hopping systems shall have hopping channel carrier frequencies separated by a minimum of 25 kHz or the 20 dB bandwidth of the hopping channel, whichever is greater. Alternatively, frequency hopping systems operating in the 2400-2483.5 MHz band may have hopping channel carrier frequencies that are separated by 25 kHz or two-thirds of the 20 dB bandwidth of the hopping channel, whichever is greater, provided the systems operate with an output power no greater than 125 mW.

According to §15.247(b)(3), for systems using digital modulation in the bands of 902-928 MHz, 2400-2483.5 MHz, and 5725-5850 MHz: 1 Watt.

5.1.4 Test Procedure

The transmitter output is connected to the Power Meter or spectrum analyzer.

5.1.5 Test Results

Channel	Frequency (MHz)	Output Power (dBm)	Output Power (W)	Limit (W)	Result
Low	2402	1.43	0.00139	1	Pass
Mid	2441	1.92	0.00156	1	Pass
High	2480	1.54	0.00143	1	Pass

5.2 Band Edges Measurement

5.2.1 Limit

According to §15.247(c), in any 100 kHz bandwidth outside the frequency bands in which the spread spectrum intentional radiator is operating, the radio frequency power that is produced by the intentional radiator shall be at least 20dB below that in the 100kHz bandwidth within the band that contains the highest level of the desired power. In addition, radiated emissions which fall in the restricted bands, as defined in §15.205(a), must also comply with the radiated emission limits specified in 15.209(a).

5.2.2 Test Equipment

Equipment	Manufacturer	Model No.	Serial No.	Last Cal.	Cal. Interval
Spectrum Analyzer	Anritsu	MS2661C	6200140915	May 29, 2009	1 Year
Test Receiver	Rohde&Schwarz	ESCS30	828985/018	May 29, 2009	1 Year
Antenna	Schwarzbeck	VULB9163	142	May 29, 2009	1 Year
Horn-antenna	Schwarzbeck	BBHA9120D	D:266	May 29, 2009	1 Year
DC Filter	MPE	23872C	N/A	May 29, 2009	1 Year

5.2.3 Block Diagram of Test Setup

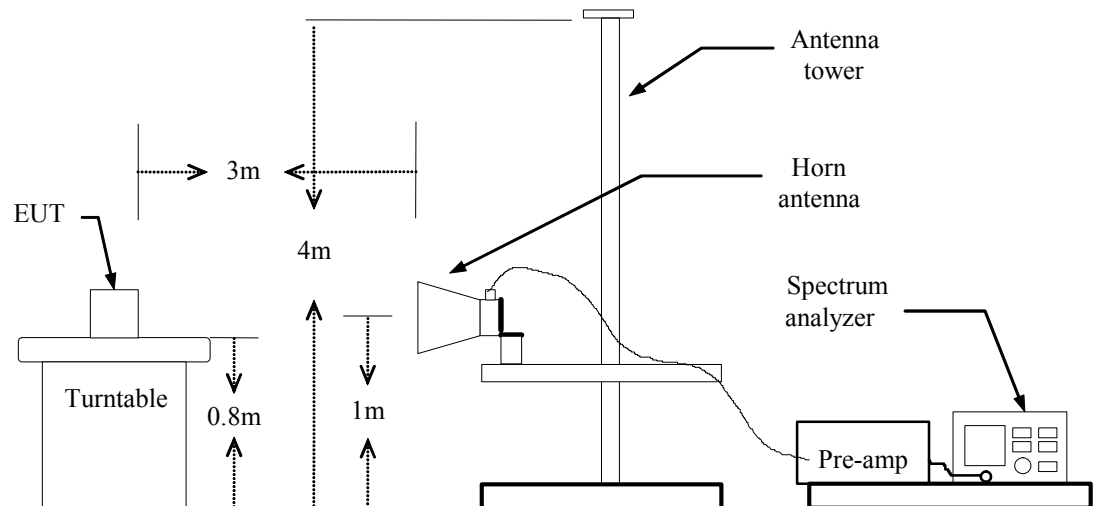

5.2.4 Test Procedure

The EUT is placed on a turntable, which is 0.8m above the ground plane. The turntable shall be rotated for 360 degrees to determine the position of maximum emission level.

EUT is set 3m away from the receiving antenna, which is varied from 1m to 4m to find out the highest emission. Set the spectrum analyzer in the following setting in order to capture the lower and upper band-edges of the emission:

Peak: RBW=VBW=1MHz / Sweep=AUTO

Repeat the procedures until the peak versus polarization are measured.

5.2.5 Test Results

CH Low

Frequency (MHz)	Ant. Pol H/V	PK Value (dBuV)	Ave Value (dBuV)	PK Limit (dBuV)	Ave Limit (dBuV)	PK Margin (dB)	Ave Margin (dB)
2390.00	V	43.19	32.30	74.00	54.00	30.81	21.70
2390.00	H	43.22	32.02	74.00	54.00	30.78	21.98

CH High

Frequency (MHz)	Ant. Pol H/V	PK Value (dBuV)	Ave Value (dBuV)	PK Limit (dBuV)	Ave Limit (dBuV)	PK Margin (dB)	Ave Margin (dB)
2483.50	V	42.38	32.75	74.00	54.00	31.62	21.25
2483.50	H	43.15	32.38	74.00	54.00	30.85	21.62

* The test data graph please refer to the following page.

Note : The attenuate 20 below fundamental level is less then FCC 15.209 limit, the attenuate 20 below fundamental level is marked in the test data graph.

Band Edges (CH Low)

Detector mode: Peak Polarity: Vertical

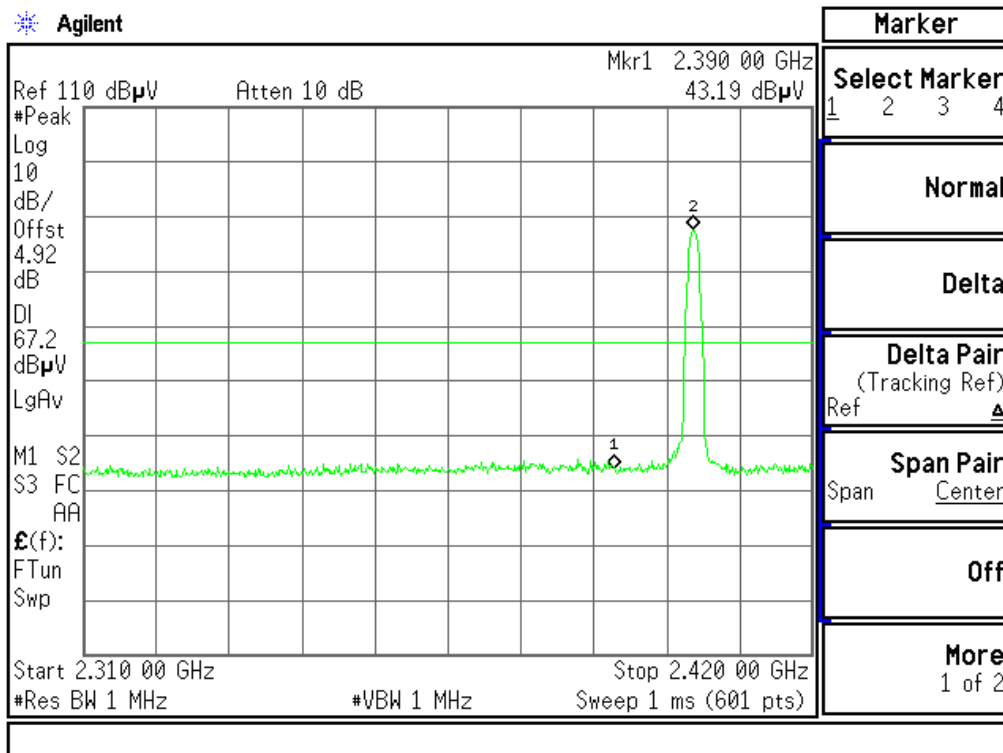

Detector mode: Peak Polarity: Horizontal

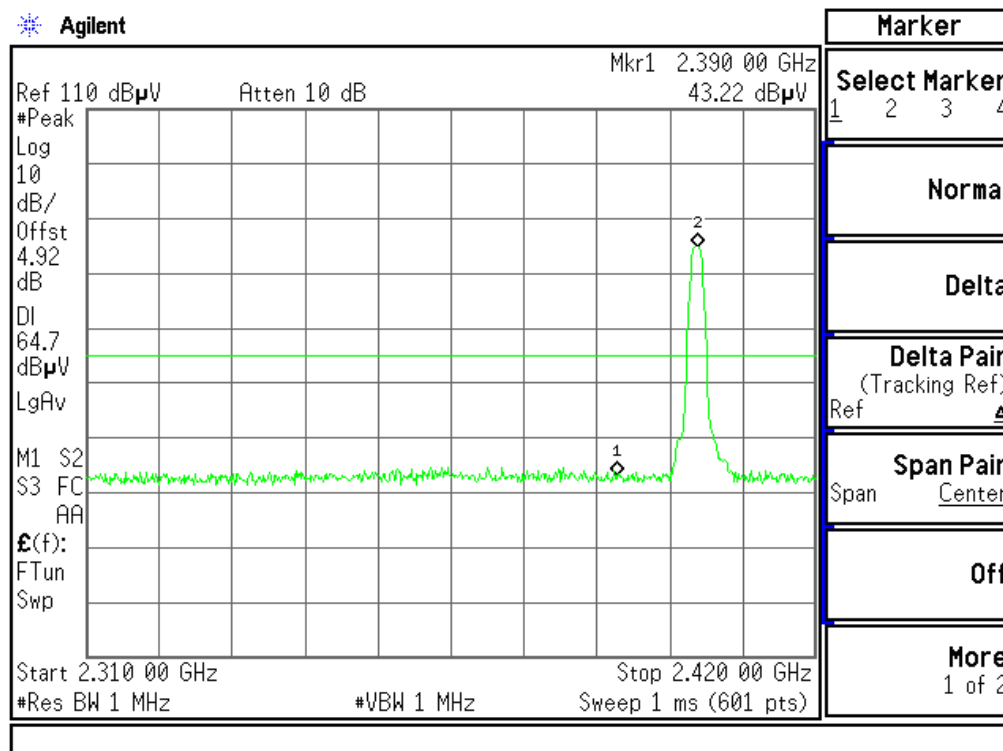

Band Edges (CH High)

Detector mode: Peak

Polarity: Vertical

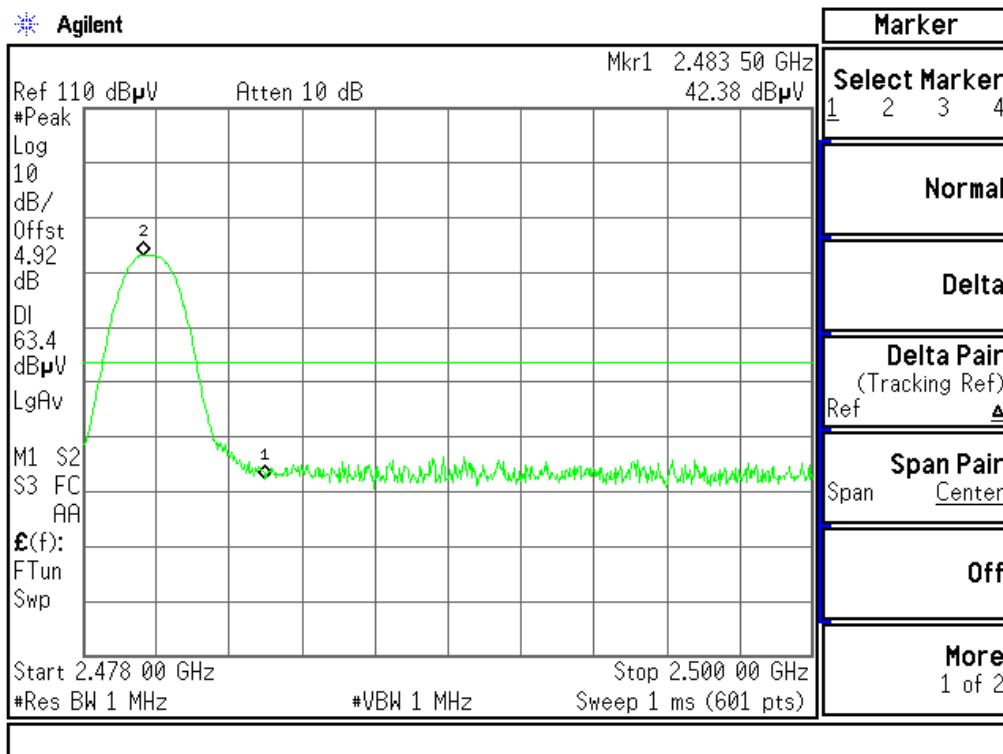

Detector mode: Peak

Polarity: Horizontal

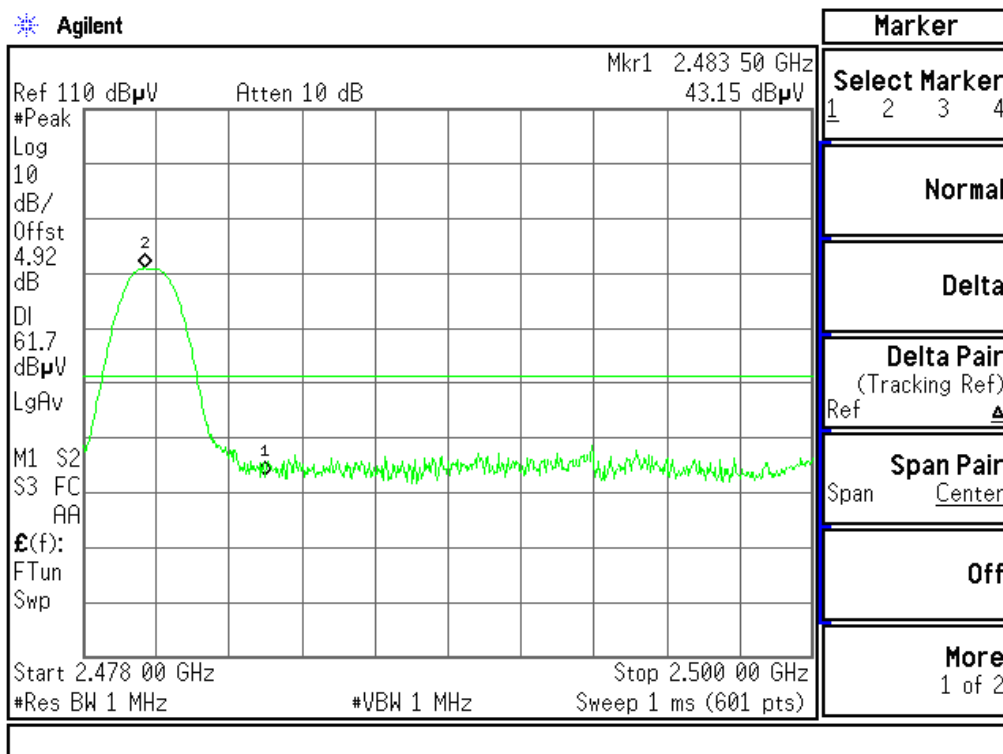

5.3 Frequency Separation

5.3.1 Limit

According to §15.247(a)(1), Frequency hopping systems shall have hopping channel carrier frequencies separated by a minimum of 25 kHz or the 20 dB bandwidth of the hopping channel, whichever is greater. Alternatively, frequency hopping systems operating in the 2400-2483.5 MHz band may have hopping channel carrier frequencies that are separated by 25 kHz or two-thirds of the 20 dB bandwidth of the hopping channel, whichever is greater, provided the systems operate with an output power no greater than 125 mW.

5.3.2 Test Equipment

Equipment	Manufacturer	Model No.	Serial No.	Last Cal.	Cal. Interval
Spectrum Analyzer	Agilent	E4407B	MY41440292	May 29, 2009	1 Year
RF Cable	Hubersuhne	Sucoflex104	FP2RX2	May 29, 2009	1 Year
DC Filter	MPE	23872C	N/A	May 29, 2009	1 Year

5.3.3 Block Diagram of Test Setup

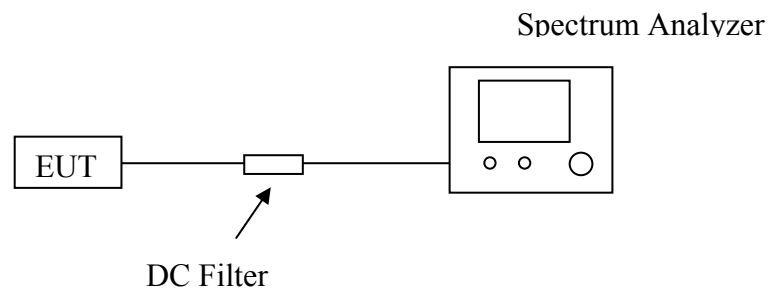

5.3.4 Test Procedure

- Place the EUT on the table and set it in transmitting mode.
- Remove the antenna from the EUT and then connect a low loss RF cable from the antenna port to the spectrum analyzer.
- Set center frequency of spectrum analyzer = middle of hopping channel.
- Set the spectrum analyzer as RBW = 30kHz, VBW = 100kHz, Span = 3MHz, Sweep = auto.
- Max hold, mark 2 peaks of hopping channel and record the 2 peaks frequency.

5.3.5 Test Results

Channel Separation (MHz)	20dB Bandwidth (kHz)	Limit (kHz)	Result
1.000	942.569	>628.38	Pass

The test data graph please refer to the following page.

Test Plot

Measurement of Channel Separation

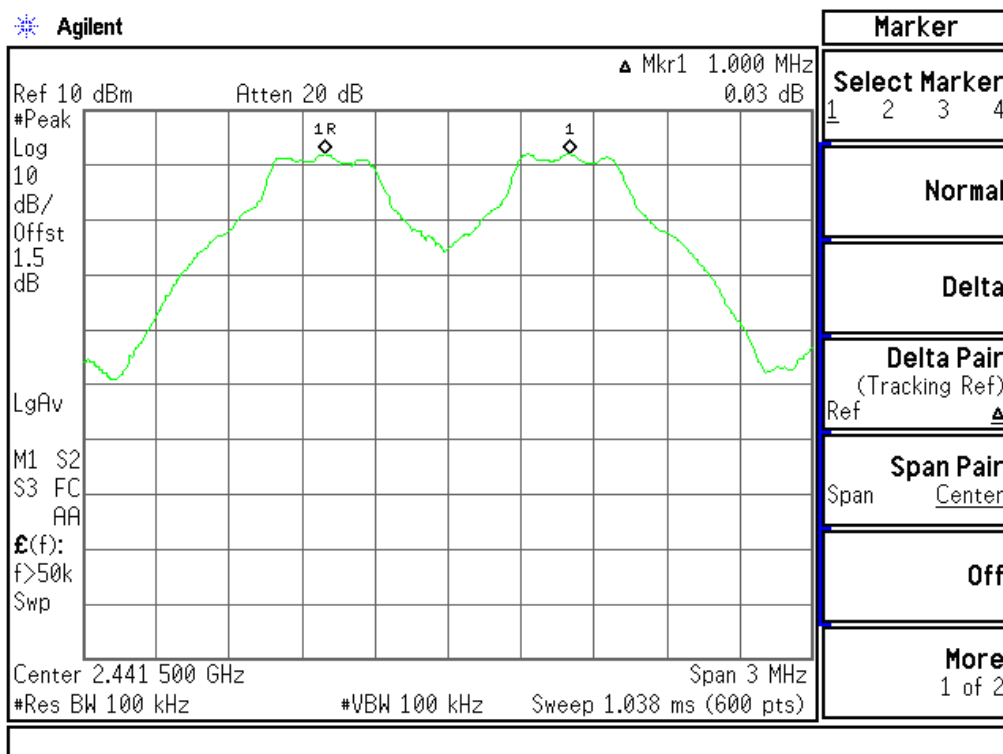
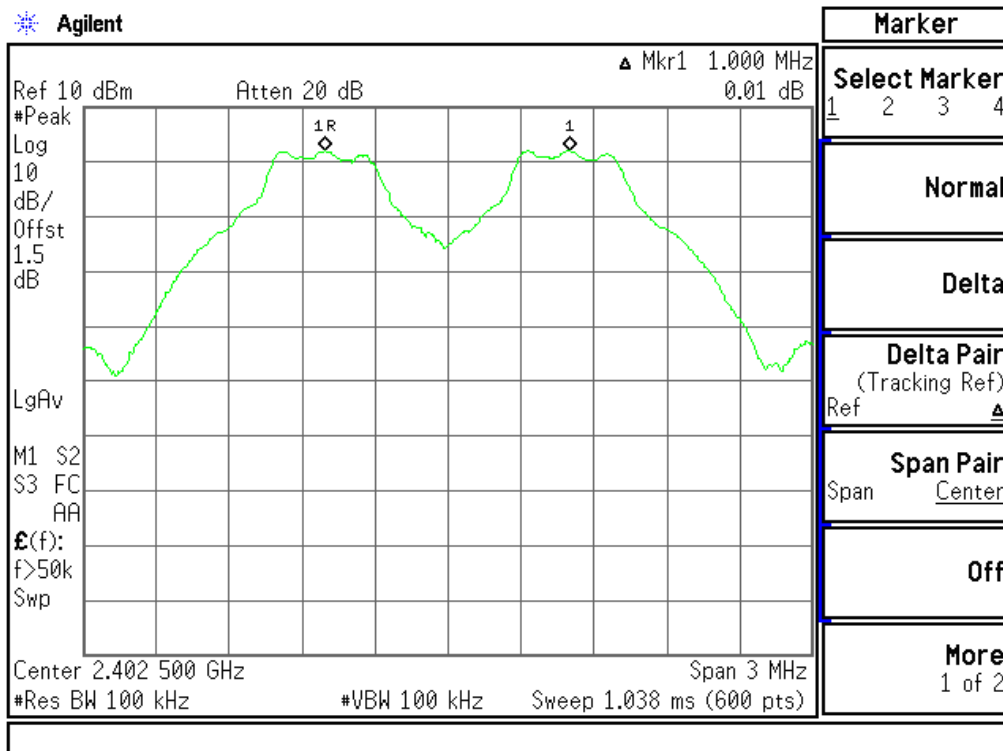

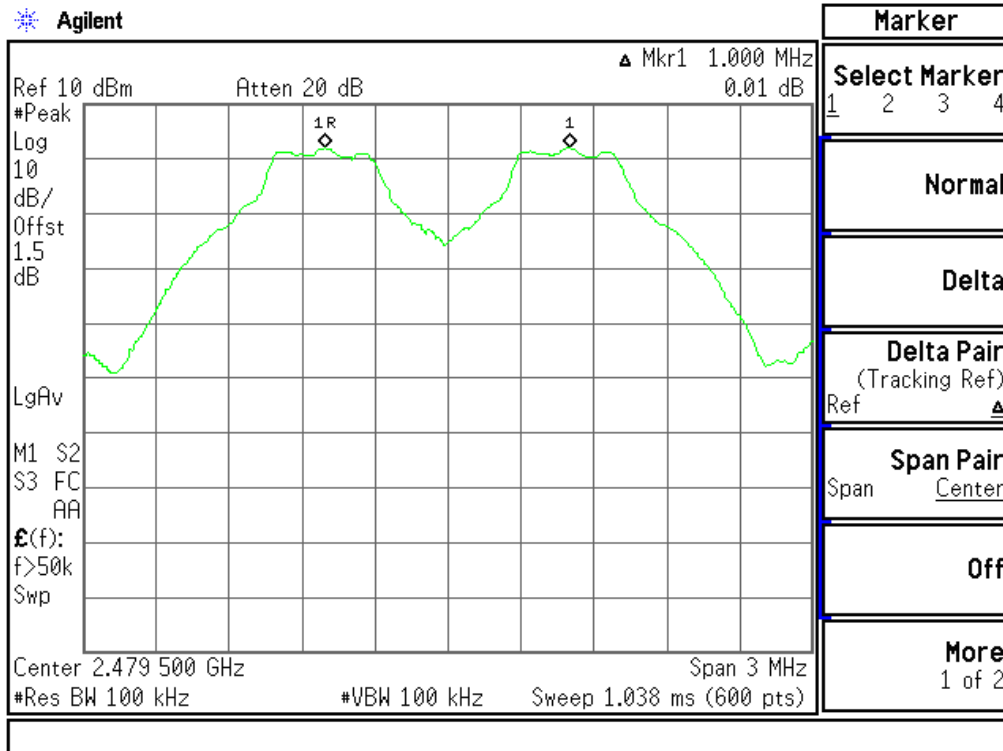

Measurement of 20dB Bandwidth

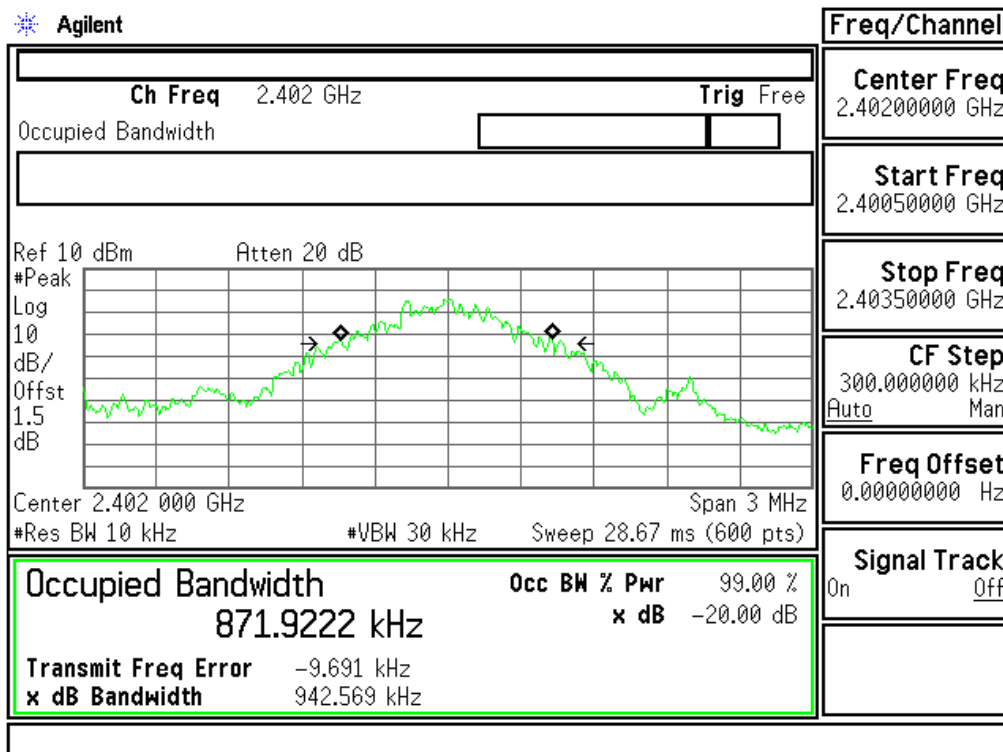

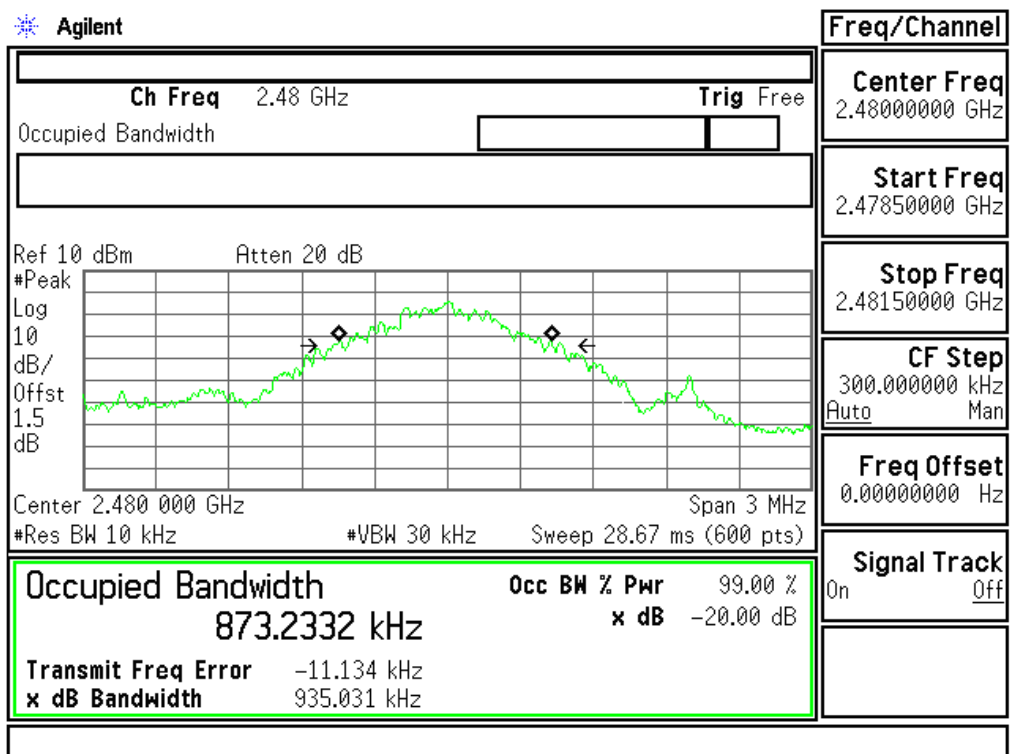
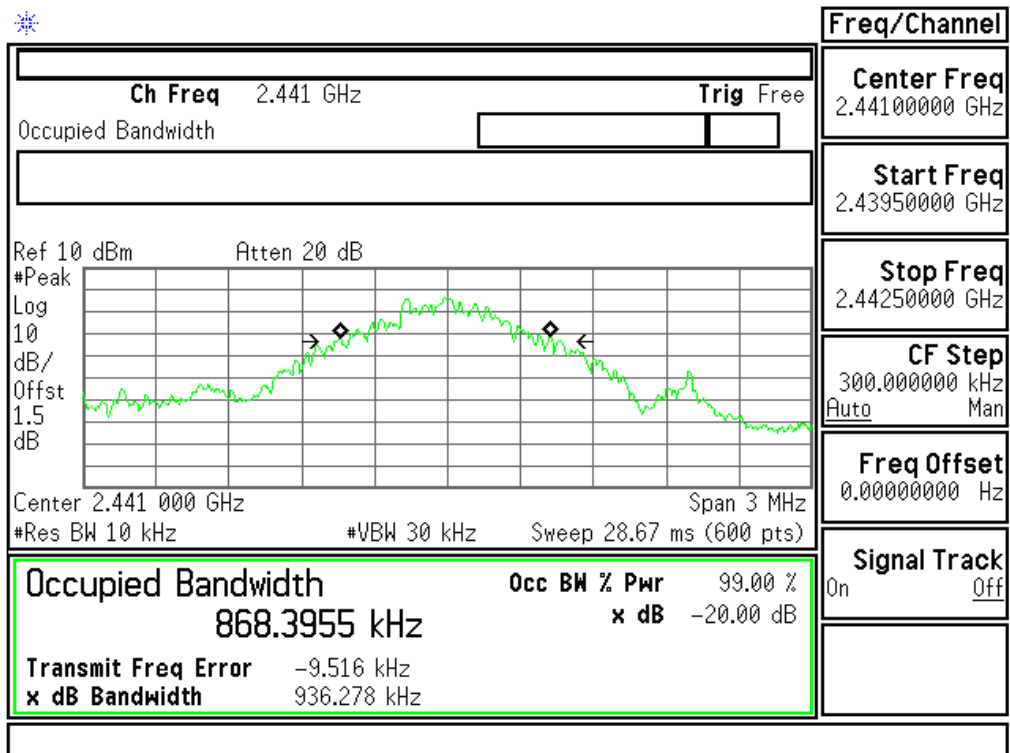

5.4 Number Of Hopping Frequency

5.4.1 Limit

According to §15.247(a)(1)(ii), Frequency hopping systems operating in the 2400MHz-2483.5 MHz bands shall use at least 75 hopping frequencies.

5.4.2 Test Equipment

Equipment	Manufacturer	Model No.	Serial No.	Last Cal.	Cal. Interval
Spectrum Analyzer	Agilent	E4407B	MY41440292	May 29, 2009	1 Year
RF Cable	Hubersuhne	Sucoflex104	FP2RX2	May 29, 2009	1 Year
DC Filter	MPE	23872C	N/A	May 29, 2009	1 Year

5.4.3 Block Diagram of Test Setup

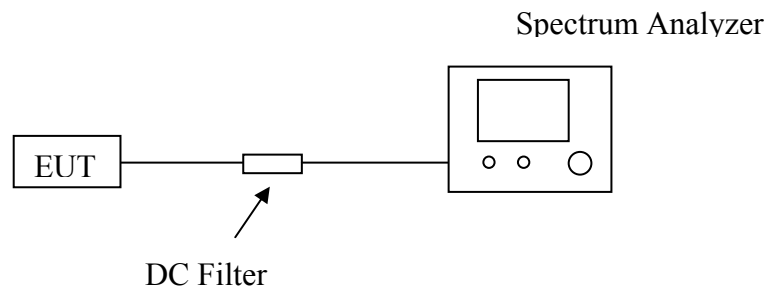

5.4.4 Test Procedure

- Place the EUT on the table and set it in transmitting mode.
- Remove the antenna from the EUT and then connect a low loss RF cable from the antenna port to the spectrum analyzer.
- Set spectrum analyzer Start=2400MHz, Stop = 2441.5MHz, Sweep = auto and Start=2441.5MHz, Stop = 2483.5MHz, Sweep = auto.
- Set the spectrum analyzer as RBW, VBW=100kHz.
- Max hold, view and count how many channel in the band.

5.4.5 Test Results

Result (No. of CH)	Limit (No. of CH)	Result
79	>75	PASS

The test data graph please refer to the following page.

Test Plot

Channel Number

2.4 GHz – 2.4415 GHz

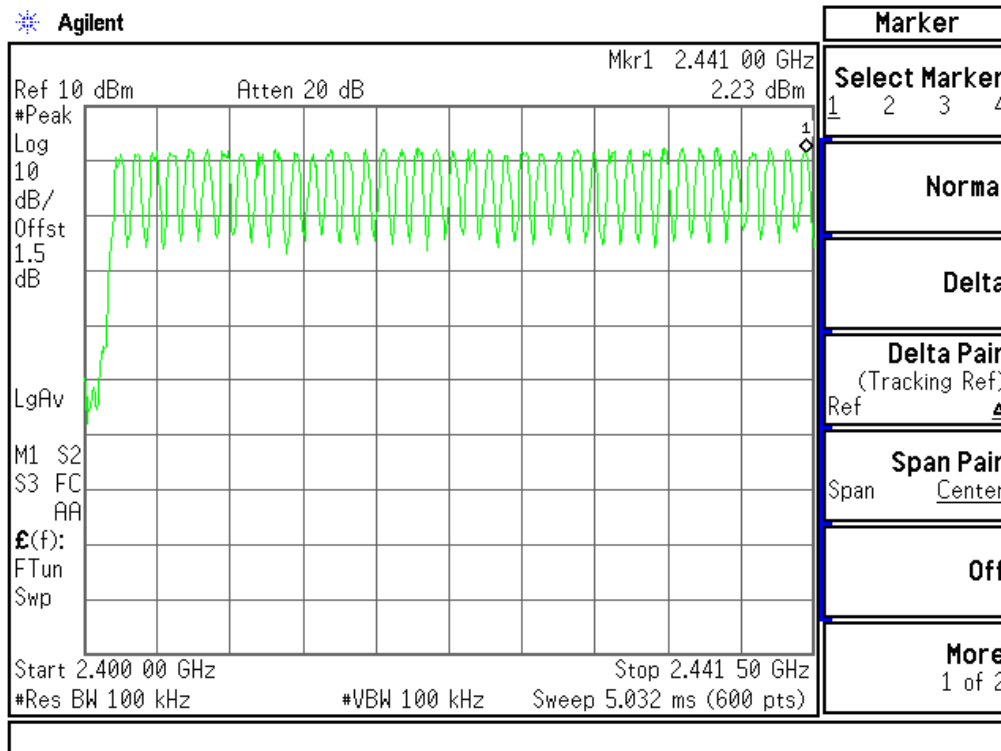

2.4415 GHz – 2.4835 GHz

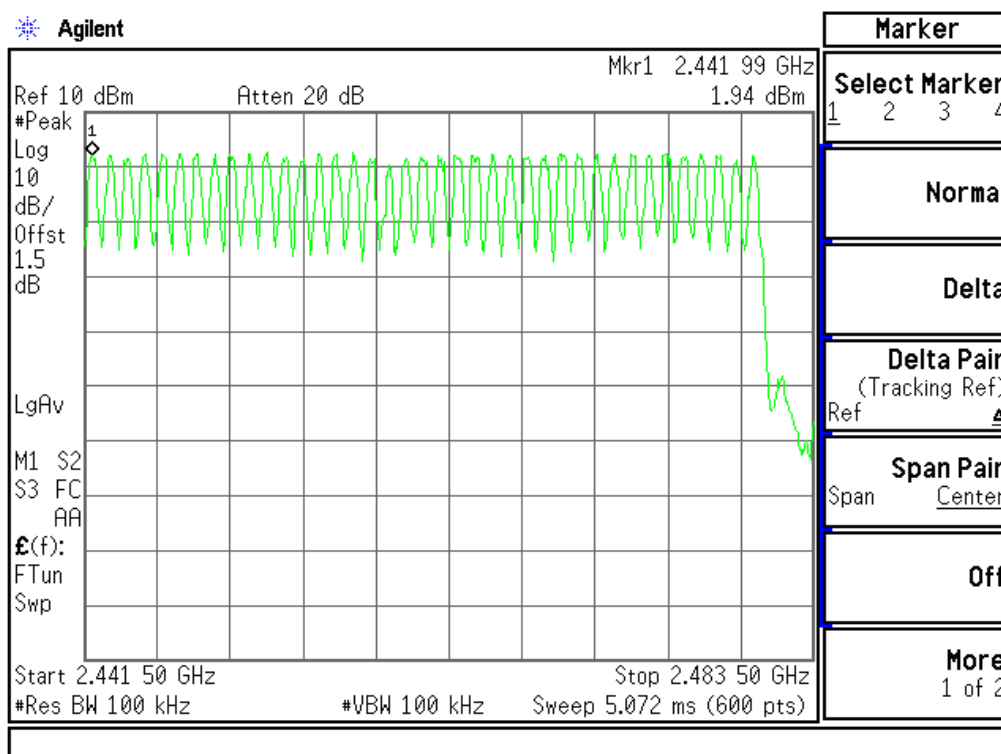

5.5 Time Of Occupancy (Dwell Time)

5.5.1 Limit

According to §15.247(a)(1)(iii), Frequency hopping systems operating in the 2400MHz-2483.5 MHz bands. The average time of occupancy on any channels shall not greater than 0.4 s within a period 0.4 s multiplied by the number of hopping channels employed.

5.5.2 Test Equipment

Equipment	Manufacturer	Model No.	Serial No.	Last Cal.	Cal. Interval
Spectrum Analyzer	Agilent	E4407B	MY41440292	May 29, 2009	1 Year
RF Cable	Hubersuhne	Sucoflex104	FP2RX2	May 29, 2009	1 Year
DC Filter	MPE	23872C	N/A	May 29, 2009	1 Year

5.5.3 Block Diagram of Test Setup

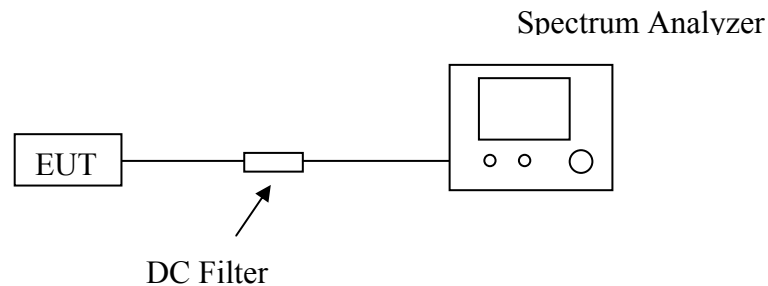

5.5.4 Test Procedure

- Place the EUT on the table and set it in transmitting mode.
- Remove the antenna from the EUT and then connect a low loss RF cable from the antenna port to the spectrum analyzer.
- Set center frequency of spectrum analyzer = operating frequency.
- Set the spectrum analyzer as RBW, VBW=1MHz, Span = 0Hz, Sweep = auto.
- Repeat above procedures until all frequency measured were complete.

5.5.5 Test Results

DH 1

$$0.400 * (1600/2)/79 * 31.6 = 128.00 \text{ (ms)}$$

DH 3

$$1.64 * (1600/4)/79 * 31.6 = 262.40 \text{ (ms)}$$

DH 5

$$2.932 * (1600/6)/79 * 31.6 = 312.77 \text{ (ms)}$$

The test data graph please refer to the following page.

Test Plot

DH 1

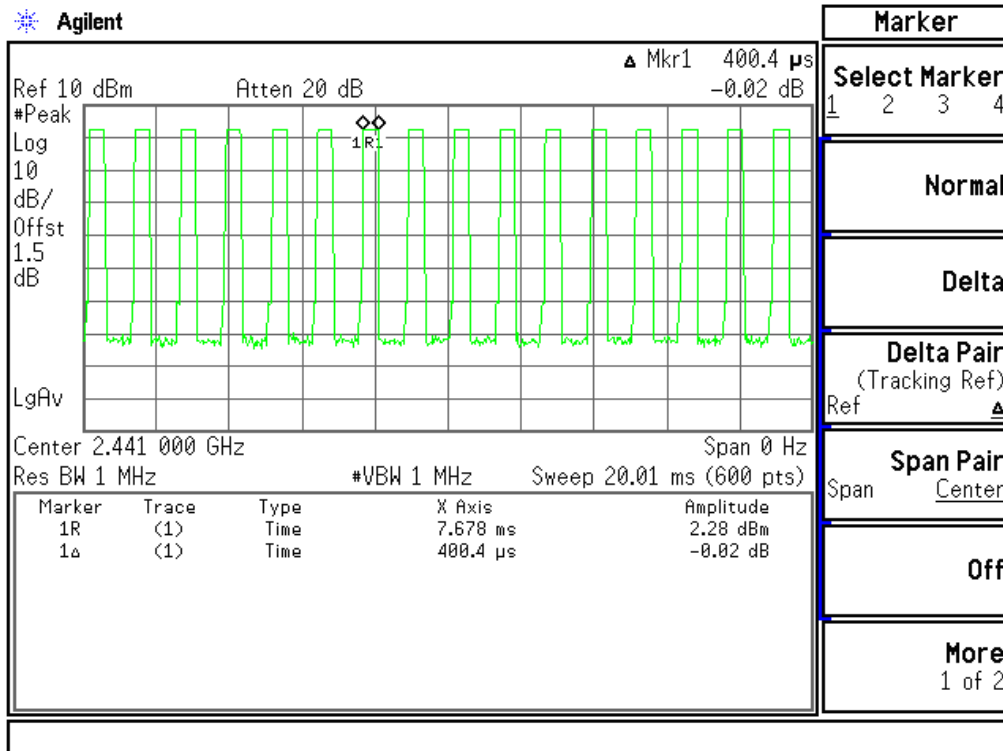

DH 3

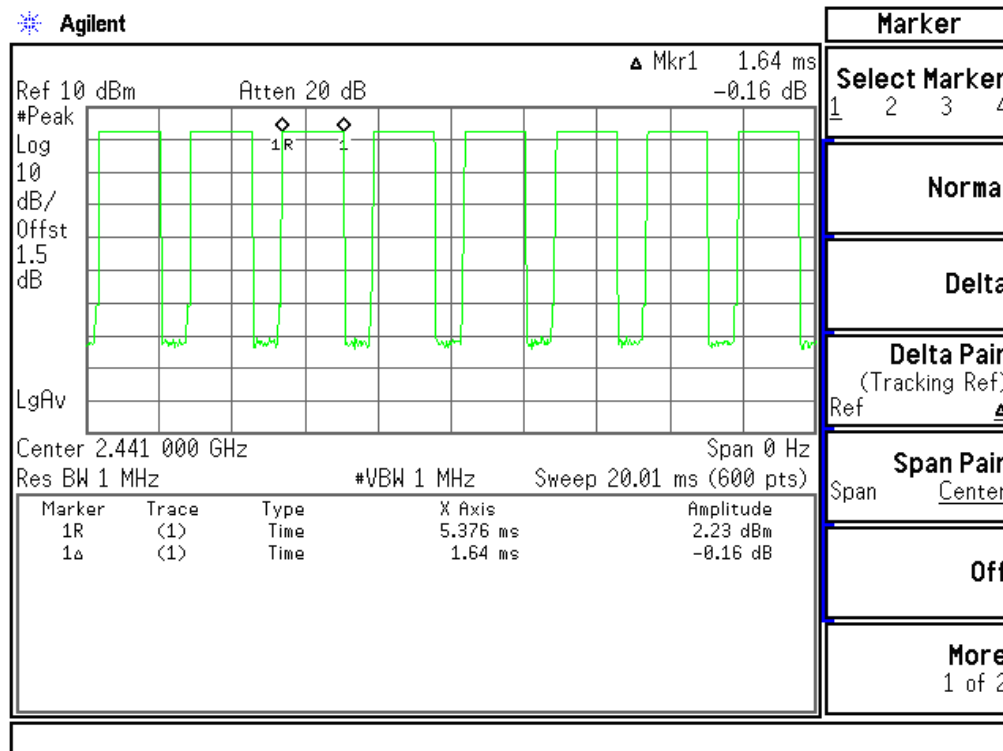

DH 5

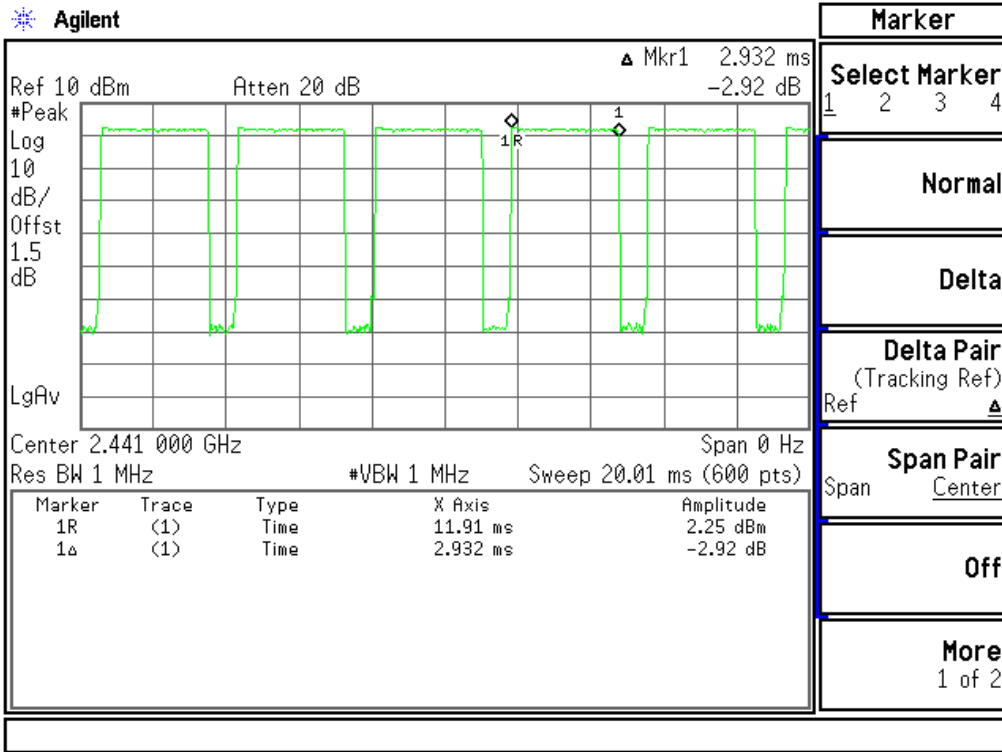

5.6 Spurious Emissions

5.6.1 Limit

In any 100 kHz bandwidth outside the frequency band in which the spread spectrum or digitally modulated intentional radiator is operating, the radio frequency power that is produced by the intentional radiator shall be at least 20 dB below that in the 100 kHz bandwidth within the band that contains the highest level of the desired power, based on either an RF conducted or a radiated measurement. Attenuation below the general limits specified in Section 15.209(a) is not required. In addition, radiated emissions which fall in the restricted bands, as defined in Section 15.205(a), must also comply with the radiated emission limits specified in Section 15.209(a) (see Section 15.205(c)).

5.6.2 Test Equipment

Equipment	Manufacturer	Model No.	Serial No.	Last Cal.	Cal. Interval
Spectrum Analyzer	Agilent	E4407B	MY41440292	May 29, 2009	1 Year
RF Cable	Hubersuhne	Sucoflex104	FP2RX2	May 29, 2009	1 Year
DC Filter	MPE	23872C	N/A	May 29, 2009	1 Year

5.6.3 Block Diagram of Test Setup

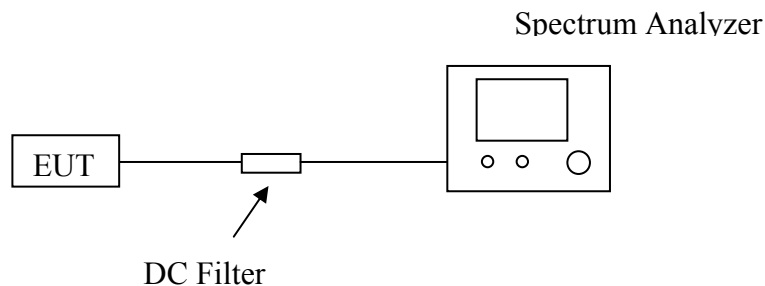

5.6.4 Test Procedure

Conducted RF measurements of the transmitter output were made to confirm that the EUT antenna port conducted emissions meet the specified limit and to identify any spurious signals that require further investigation or measurements on the radiated emissions site.

The transmitter output is connected to the spectrum analyzer. The resolution bandwidth is set to 100 KHz. The video bandwidth is set to 100 KHz.

Measurements are made over the 30MHz to 26GHz range with the transmitter set to the lowest, middle, and highest channels.

5.6.5 Test Results

No non-compliance noted

The test data graph please refer to the following page.

Test Plot

CH Low

30MHz ~ 2.9GHz

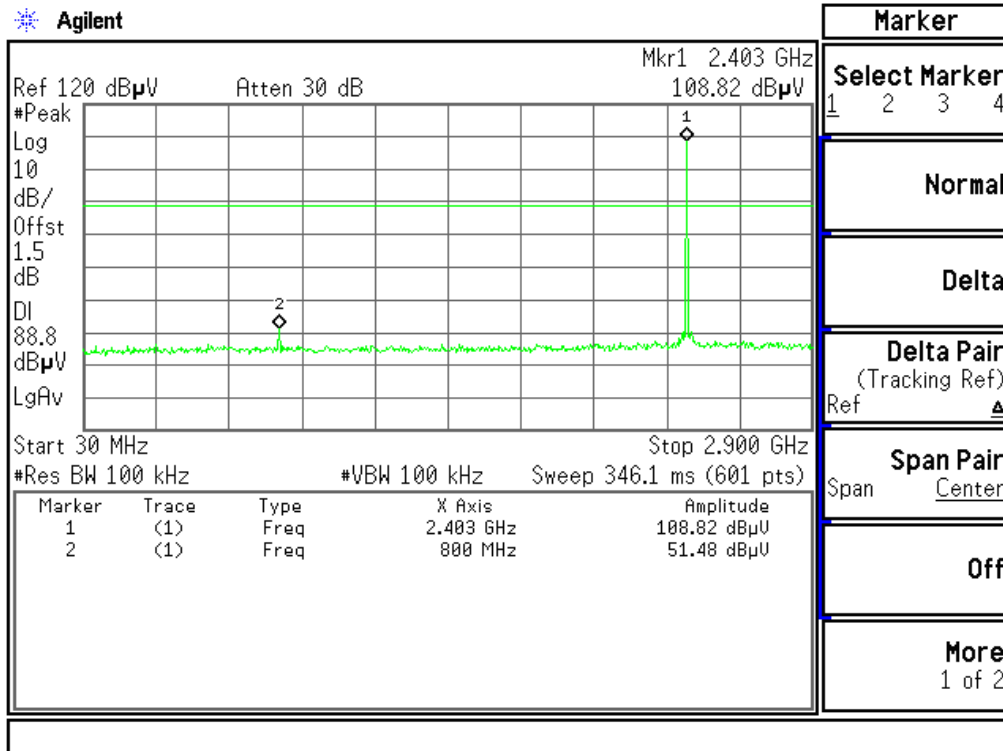

2.9GHz ~ 26.5GHz

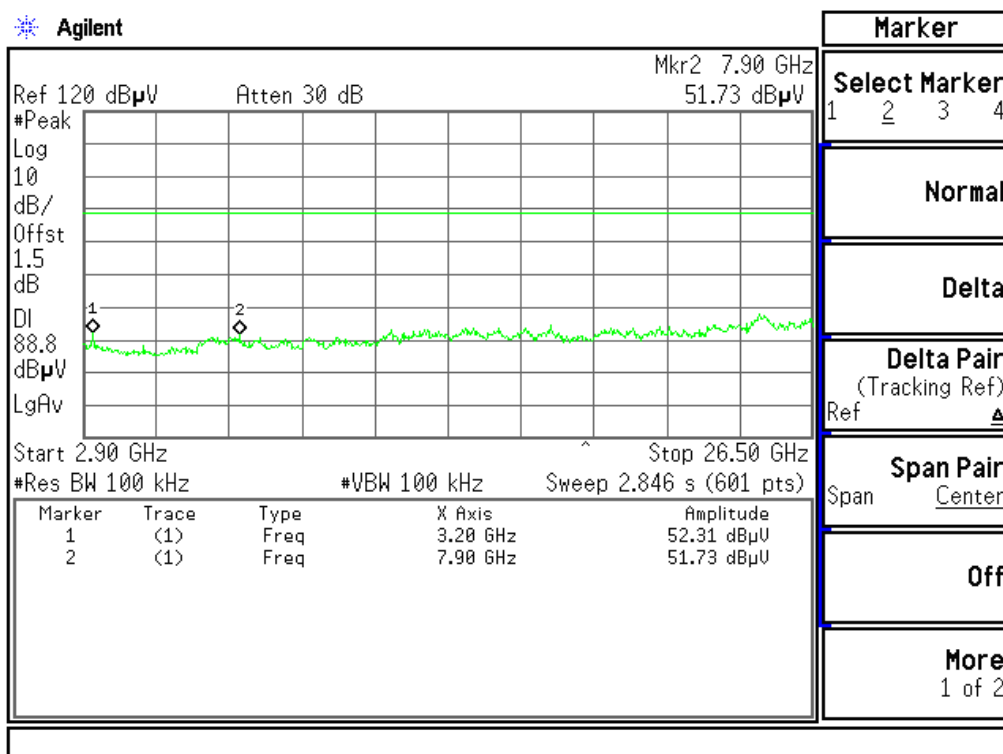

CH Mid

30MHz ~ 2.9GHz

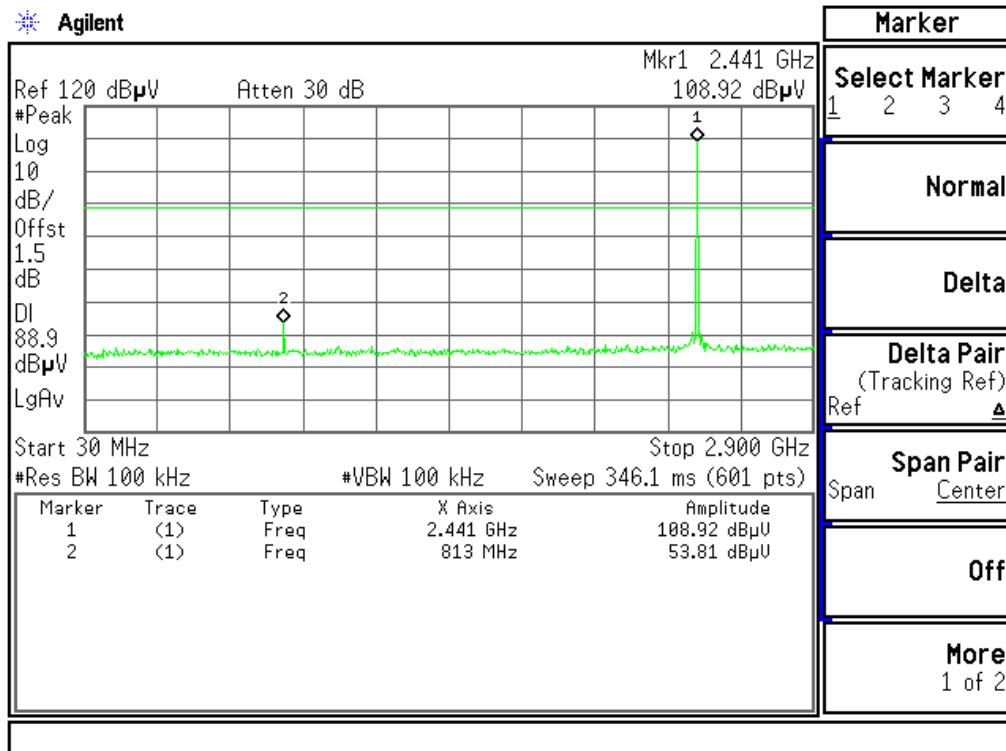

2.9GHz ~ 26.5GHz

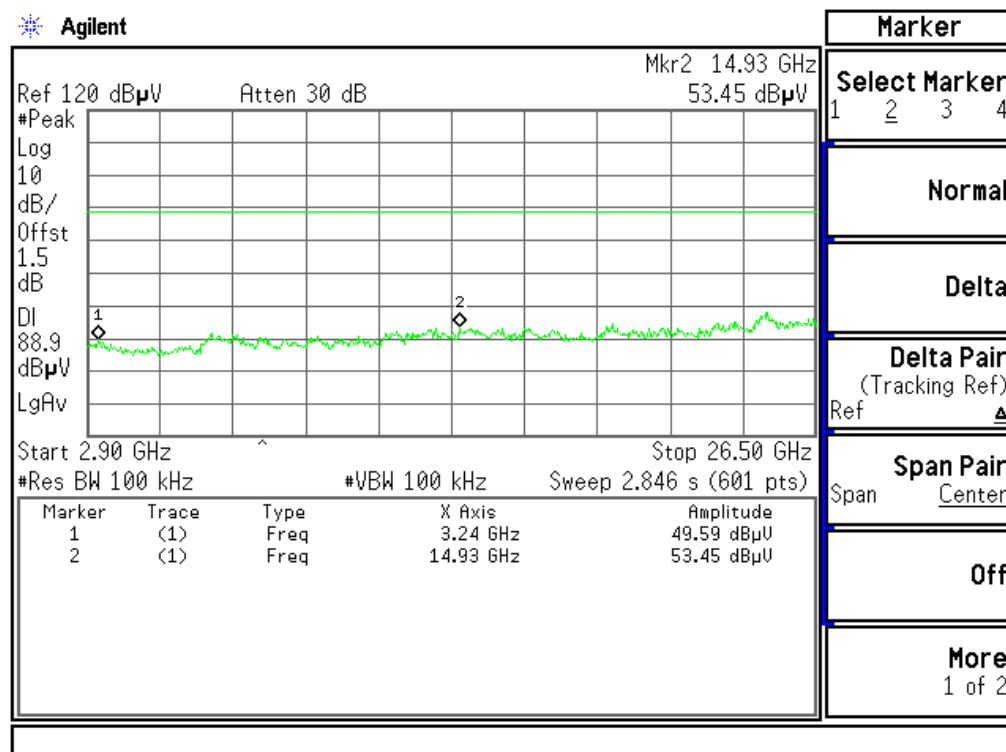

CH High

30MHz ~ 2.9GHz

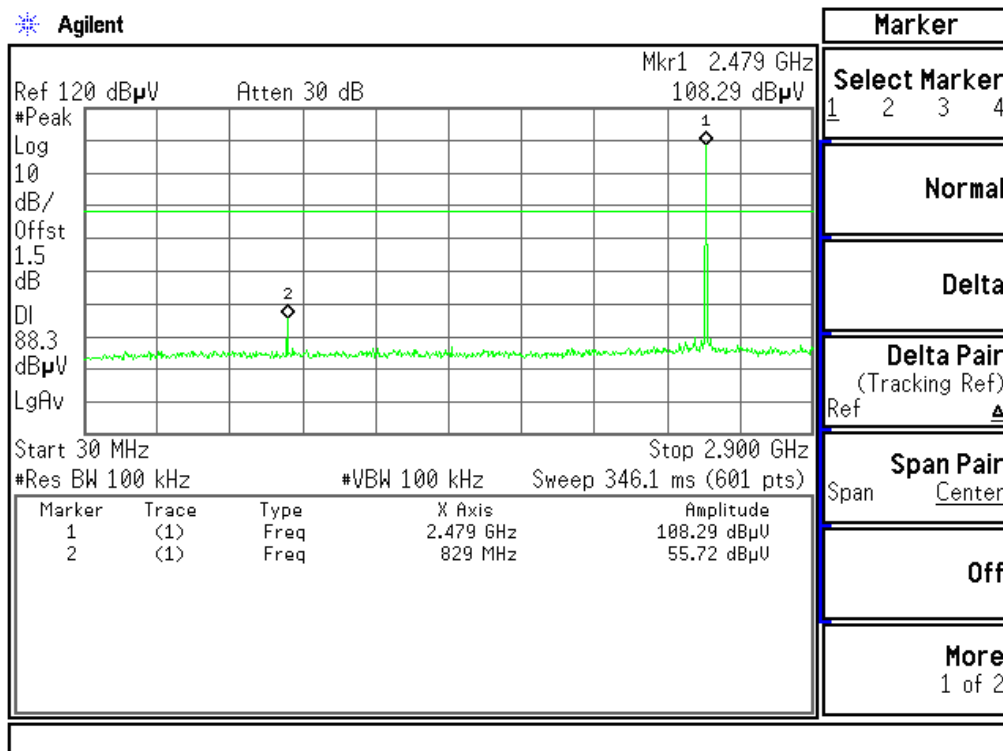

2.9GHz ~ 26.5GHz

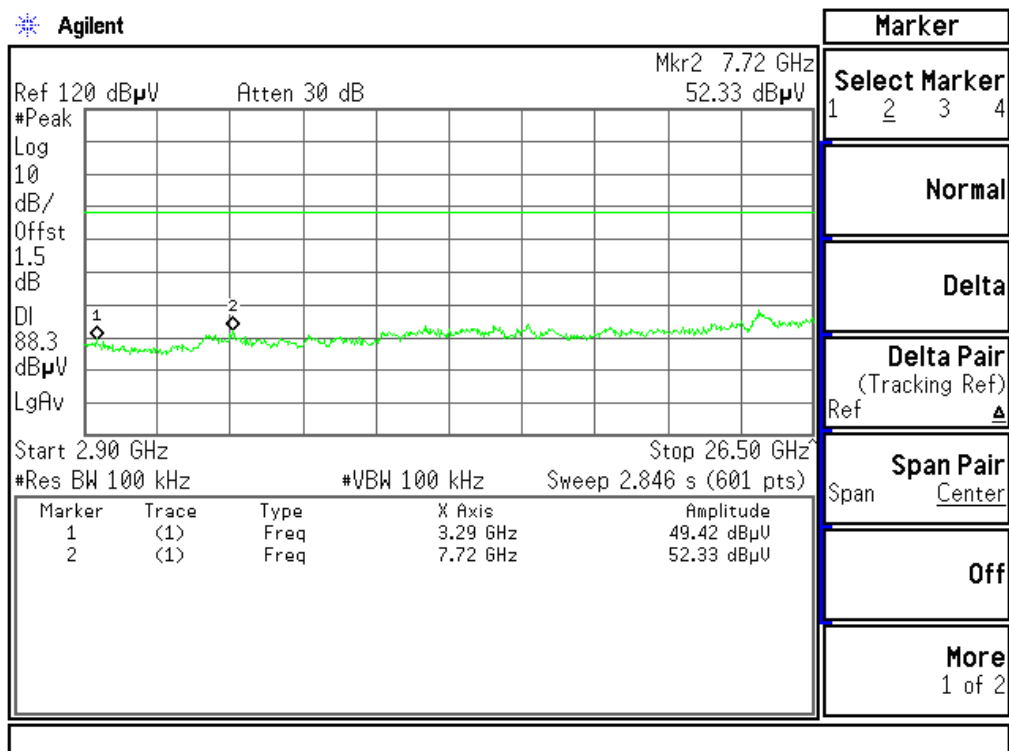

6. RADIATED EMISSION MEASUREMENT

6.1 Test Equipment

Item	Equipment	Manufacturer	Model No.	Serial No.	Last Cal.	Cal. Interval
1	Spectrum Analyzer	ANRITSU	MS2661C	6200140915	May 29, 2009	1 Year
2	Test Receiver	Rohde & Schwarz	ESCS30	828985/018	May 29, 2009	1 Year
3	Antenna	Schwarzbeck	VULB9163	142	May 29, 2009	1 Year
4	Horn-antenna	SCHWARZBECK	BBHA9120D	D:266	May 29, 2009	1 Year
5	DC Filter	MPE	23872C	N/A	May 29, 2009	1 Year

6.2 Block Diagram of Test Setup

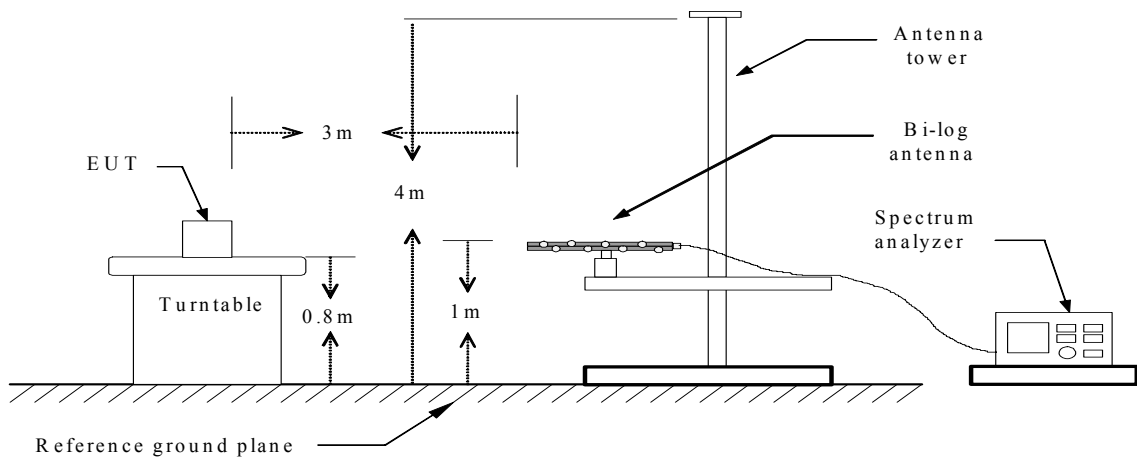

Below 1 GHz

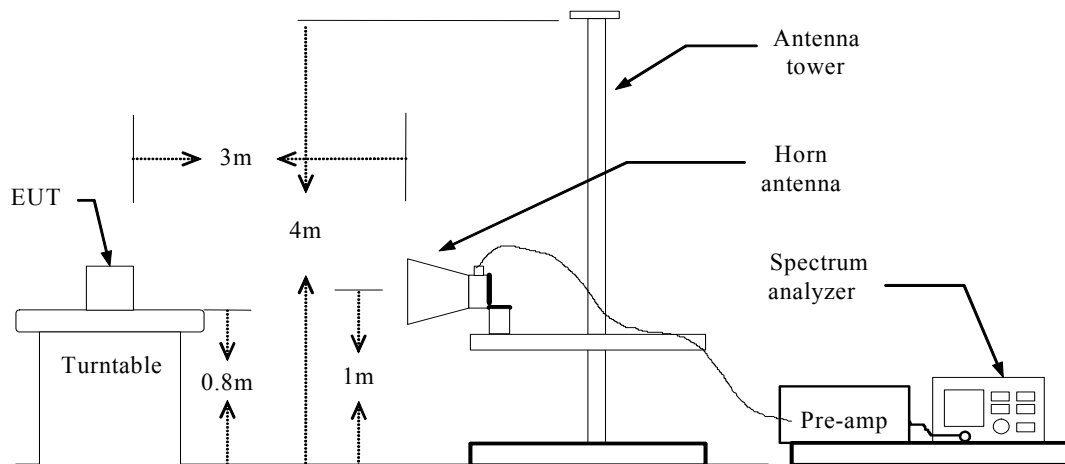

Above 1 GHz

6.3 Radiated Emission Limit

15.205 (a) Except as shown in paragraph (d) of this section, only spurious emissions are permitted in any of the frequency bands listed below:

MHz	MHz	MHz	GHz
0.090-0.110	16.42-16.423	399.9-410	4.5-5.15
\1\ 0.495-0.505	16.69475-16.69525	608-614	5.35-5.46
2.1735-2.1905	16.80425-16.80475	960-1240	7.25-7.75
4.125-4.128	25.5-25.67	1300-1427	8.025-8.5
4.17725-4.17775	37.5-38.25	1435-1626.5	9.0-9.2
4.20725-4.20775	73-74.6	1645.5-1646.5	9.3-9.5
6.215-6.218	74.8-75.2	1660-1710	10.6-12.7
6.26775-6.26825	108-121.94	1718.8-1722.2	13.25-13.4
6.31175-6.31225	123-138	2200-2300	14.47-14.5
8.291-8.294	149.9-150.05	2310-2390	15.35-16.2
8.362-8.366	156.52475-156.52525	2483.5-2500	17.7-21.4
8.37625-8.38675	156.7-156.9	2690-2900	22.01-23.12
8.41425-8.41475	162.0125-167.17	3260-3267	23.6-24.0
12.29-12.293	167.72-173.2	3332-3339	31.2-31.8
12.51975-12.52025	240-285	3345.8-3358	36.43-36.5
12.57675-12.57725	322-335.4	3600-4400	(\2)
13.36-13.41			

\1\ Until February 1, 1999, this restricted band shall be 0.490-0.510 MHz.

\2\ Above 38.6

Part 15.205 (b) Except as provided in paragraphs (d) and (e), the field strength of emissions appearing within these frequency bands shall not exceed the limits shown in Section 15.209. At frequencies equal to or less than 1000 MHz, compliance with the limits in Section 15.209 shall be demonstrated using measurement instrumentation employing a CISPR quasi-peak detector.

Above 1000 MHz, compliance with the emission limits in Section 15.209 shall be demonstrated based on the average value of the measured emissions. The provisions in Section 15.35 apply to these measurements.

Part 15.209 (a) Except as provided elsewhere in this Subpart, the emissions from an intentional radiator shall not exceed the field strength levels specified in the following table:

Frequency (MHz)	Field Strength (microvolts/meter)	Measurement Distance (meters)
30-88	100	3
88-216	150	3
216-960	200	3
Above 960	500	3

6.4 Test Results

PASS.

The test data please refer to following page.

Below 1GHz**Operation Mode:** Normal link**Test Date:** January 29, 2010**Temperature:** 23°C**Humidity:** 50 % RH

Freq. (MHz)	Ant.Pol. H/V	Detector Mode	Reading (dBuV)	Factor (dB)	Actual FS (dBuV/m)	Limit (dBuV/m)	Margin (dB)
53.32	V	Peak	17.4	13.54	30.94	43.5	-12.56
127.31	V	Peak	18.39	7.59	25.98	43.5	-17.52
168.34	V	Peak	19.93	9.78	29.71	43.5	-13.79
300.48	V	Peak	17.46	13.88	31.34	46.0	-14.66
371.98	V	Peak	18.73	16.13	34.86	46.0	-11.14
844.12	V	Peak	16.34	20.31	36.65	46.0	-9.35
144.58	H	Peak	21.03	9.01	30.04	43.5	-13.46
215.24	H	Peak	16.08	10.81	26.89	43.5	-16.61
270.53	H	Peak	18.94	13.10	32.04	46.0	-13.96
298.90	H	Peak	18.56	13.89	32.45	46.0	-13.55
369.89	H	Peak	17.01	16.08	33.09	46.0	-12.91
883.51	H	Peak	14.37	22.37	36.74	46.0	-9.26

Notes:

1. Measuring frequencies from 30 MHz to the 1GHz, No emission found between lowest internal used/generated frequency to 30 MHz.
2. Radiated emissions measured in frequency range from 30 MHz to 1000MHz were made with an instrument using Peak detector mode.
3. Data of measurement within this frequency range shown " --- " in the table above means the reading of emissions are attenuated more than 20dB below the permissible limits or the field strength is too small to be measured.
4. The IF bandwidth of SPA between 30MHz to 1GHz was 100kHz.

Above 1GHz**Operation Mode:** TX/ CH Low**Test Date:** January 29, 2010**Temperature:** 23°C**Humidity:** 50 % RH

Freq. (MHz)	Ant. Pol H/V	Peak Reading (dBuV)	AV Reading (dBuV)	Ant. / CL CF (dB)	Actual Fs		Peak Limit (dBuV/m)	AV Limit (dBuV/m)	Margin (dB)	Remark
					Peak (dBuV/m)	AV (dBuV/m)				
4803.00	V	40.68	28.84	10.98	51.66	39.82	74	54	-14.18	Avg
7207.39	V	32.13	19.64	18.54	50.67	38.18	74	54	-15.82	Avg
4803.67	H	40.4	29.28	10.98	51.38	40.26	74	54	-13.74	Avg
7206.00	H	33.09	21.44	18.53	51.62	39.97	74	54	-14.03	Avg

Operation Mode: TX/ CH Mid**Test Date:** January 29, 2010**Temperature:** 23°C**Humidity:** 50% RH

Freq. (MHz)	Ant. Pol H/V	Peak Reading (dBuV)	AV Reading (dBuV)	Ant. / CL CF (dB)	Actual Fs		Peak Limit (dBuV/m)	AV Limit (dBuV/m)	Margin (dB)	Remark
					Peak (dBuV/m)	AV (dBuV/m)				
4883.10	V	40.69	28.88	10.98	51.67	39.86	74	54	-14.14	Avg
7324.33	V	32.89	21.58	18.54	51.43	40.12	74	54	-13.88	Avg
4883.67	H	39.46	28.83	10.98	50.44	39.81	74	54	-14.19	Avg
7324.25	H	33.19	20.52	18.53	51.72	39.05	74	54	-14.95	Avg

Operation Mode: TX/ CH High**Test Date:** January 29, 2010**Temperature:** 23°C**Humidity:** 50 % RH

Freq. (MHz)	Ant. Pol H/V	Peak Reading (dBuV)	AV Reading (dBuV)	Ant. / CL CF (dB)	Actual Fs		Peak Limit (dBuV/m)	AV Limit (dBuV/m)	Margin (dB)	Remark
					Peak (dBuV/m)	AV (dBuV/m)				
4961.00	V	40.04	28.83	10.98	51.02	39.81	74	54	-14.19	Avg
7441.69	V	31.59	21.33	18.54	50.13	39.87	74	54	-14.13	Avg
4960.25	H	38.25	27.53	10.98	49.23	38.51	74	54	-15.49	Avg
7440.00	H	31.59	20.24	18.53	50.12	38.77	74	54	-15.23	Avg

7. POWER LINE CONDUCTED EMISSIONS

7.1 Test Equipment

Equipment	Manufacturer	Model No.	Serial No.	Last Cal.	Cal. Interval
Test Receiver	Rohde & Schwarz	ESCS30	828985/018	Mar 30, 2009	1 Year
L.I.S.N	Rohde & Schwarz	ESH2-Z5	834549/005	Mar 30, 2009	1 Year
Pulse Limiter	Rohde & Schwarz	ESH3-Z2	100006	Mar 30, 2009	1 Year
50 Coaxial Switch	Anritsu	MP59B	M20531	Mar 30, 2009	1 Year

7.2 Block Diagram of Test Setup

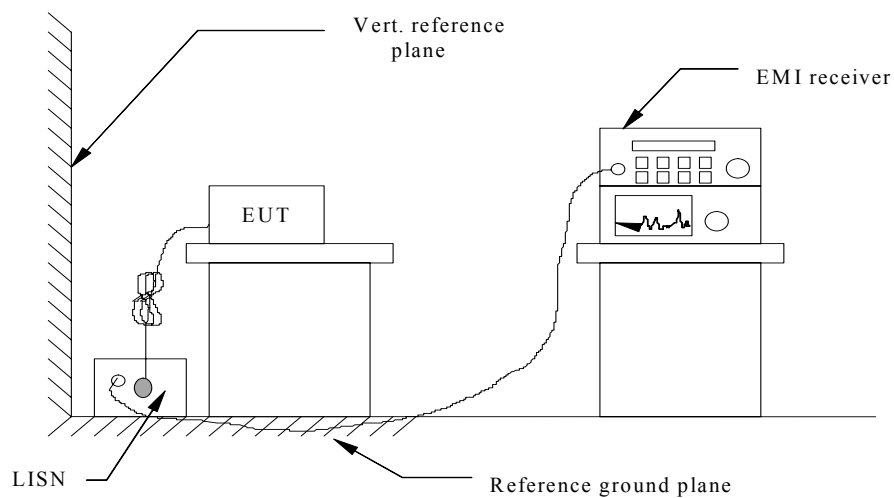

7.3 Conducted Emission Limit

For an intentional radiator which is designed to be connected to the public utility (AC) power line, the radio frequency voltage that is conducted back onto the AC power line on any frequency or frequencies within the band 150 kHz to 30 MHz shall not exceed 250 microvolts (The limit decreases linearly with the logarithm of the frequency in the range 0.15 MHz to 0.50 MHz). The limits at specific frequency range is listed as follows:

Frequency Range (MHz)	Limits (dB μ V)	
	Quasi-peak	Average
0.15 to 0.50	66 to 56	56 to 46
0.50 to 5	56	46
5 to 30	60	50

7.4 Test Results

PASS.

The test data please refer to following page.

Conducted Emission

Operation Mode: TX/ CH Mid

Test Date: January 29, 2010

Temperature: 23°C

Humidity: 50 % RH

Freq. (MHz)	Q.P. Raw reading (dBuV)	AVG Raw reading (dBuV)	Correction factor(dB)	Q.P. Limit (dBuV)	AVG Limit (dBuV)	Q.P. Margin (dB)	AVG Margin (dB)	Note
0.185	57.30	42.08	0.00	64.26	54.26	6.96	12.18	Line
0.370	50.79	30.11	0.00	58.50	48.50	7.71	18.39	Line
0.575	42.21	26.00	0.00	56.00	46.00	13.79	20.00	Line
0.925	38.27	20.69	0.00	56.00	46.00	17.73	25.31	Line
2.140	39.64	17.96	0.00	56.00	46.00	16.36	28.04	Line
3.207	40.19	17.41	0.00	56.00	46.00	15.81	28.59	Line
0.175	54.90	41.73	0.00	64.32	54.32	9.42	12.59	Neutral
0.350	54.35	36.47	0.00	58.96	48.96	4.61	12.49	Neutral
0.545	43.28	26.68	0.00	56.00	46.00	12.72	19.32	Neutral
0.695	39.40	22.15	0.00	56.00	46.00	16.60	23.85	Neutral
1.845	39.81	19.22	0.00	56.00	46.00	16.19	26.78	Neutral
3.020	38.77	16.91	0.00	56.00	46.00	17.23	29.09	Neutral

8. ANTENNA REQUIREMENT

8.1 Standard Applicable

According to §15.203, Antenna requirement.

An intentional radiator shall be designed to ensure that no antenna other than that furnished by the re-sponsible party shall be used with the device. The use of a permanently attached antenna or of an antenna that uses a unique coupling to the intentional radiator shall be considered sufficient to comply with the provisions of this Section. The manufacturer may design the unit so that a broken antenna can be re-placed by the user, but the use of a standard antenna jack or electrical connector is prohibited. This requirement does not apply to carrier current devices or to devices operated under the provisions of Sections 15.211, 15.213, 15.217, 15.219, or 15.221. Further, this requirement does not apply to intentional radiators that must be professionally installed, such as perimeter protection systems and some field disturbance sensors, or to other intentional radiators which, in accordance with Section 15.31(d), must be measured at the installation site. However, the installer shall be responsible for ensuring that the proper antenna is employed so that the limits in this Part are not exceeded.

And according to §15.247(4)(1), system operating in the 2400-2483.5MHz bands that are used exclusively for fixed, point-to-point operations may employ transmitting antennas with directional gain greater than 6dBi provided the maximum peak output power of the intentional radiator is reduced by 1 dB for every 3 dB that the directional gain of the antenna exceeds 6 dBi.

8.2 Antenna Connected Construction

The directional gains of antenna used for transmitting is 1.5dBi, and the antenna connector is designed with permanent attachment and no consideration of replacement. Please see EUT photo for details.

9. RADIO FREQUENCY EXPOSURE

9.1 Limit

According to §15.247(i), systems operating under the provisions of this section shall be operated in a manner that ensures that the public is not exposed to radio frequency energy levels in excess of the Commission's guidelines. See § 1.1307(b)(1) of this chapter.

9.2 EUT Specification

EUT	2.4G Wireless Mouse
Frequency Band (Operating)	<input type="checkbox"/> WLAN: 2.412GHz ~ 2.462GHz <input type="checkbox"/> WLAN: 5.18GHz ~ 5.32GHz / 5.50GHz ~ 5.70GHz <input type="checkbox"/> WLAN: 5.745GHz ~ 5.825GHz <input checked="" type="checkbox"/> Others: Bluetooth: 2.402GHz ~ 2.480GHz
Device Category	<input checked="" type="checkbox"/> Portable (<20cm separation) <input type="checkbox"/> Mobile (>20cm separation) <input type="checkbox"/> Others
Exposure Classification	<input type="checkbox"/> Occupational/Controlled exposure ($S = 5mW/cm^2$) <input checked="" type="checkbox"/> General Population/Uncontrolled exposure ($S=1mW/cm^2$)
Antenna Diversity	<input checked="" type="checkbox"/> Single antenna <input type="checkbox"/> Multiple antennas <input type="checkbox"/> Tx diversity <input type="checkbox"/> Rx diversity <input type="checkbox"/> Tx/Rx diversity
Max. Output Power	1.92 dBm (1.56mW)
Antenna Gain (Max)	1.5 dBi
Evaluation Applied	<input type="checkbox"/> MPE Evaluation <input type="checkbox"/> SAR Evaluation <input checked="" type="checkbox"/> N/A
Remark: 1. The maximum output power is <u>1.92dBm (1.56mW) at 2441MHz</u> 2. DTS device is not subject to routine RF evaluation; MPE estimate is used to justify the compliance. 3. For mobile or fixed location transmitters, no SAR consideration applied. The minimum separation generally be used is at least 20 cm, even if the calculations indicate that the MPE distance would be lesser.	

9.3 Test Results

Non-compliance.

(SAR evaluation is not required for the portable device while its maximum output power is lower than the general population low threshold: $60/f$ (GHz) = $60/2.441 = 24.58mW$)

----- END REPORT -----