

FCC CERTIFICATION TEST REPORT

FOR

FCC ID:X5B-PL8560C

Report Reference No.: 13EAB08035 41

Date of issue.....: 2013-08-21

Testing Laboratory: ATT Product Service Co., Ltd.

Address: No. 3, ChangLianShan Industrial Park, ChangAn Town,
DongGuan City, GuangDong, China.

Applicant's name: Performance Designed Products,LLC

Address: 14144 Ventura Blvd,Suite 200,Sherman Oaks,CA 91423
U.S.A

Manufacturer: Performance Designed Products,LLC

Test specification:

Test item description: RockCandy Wireless Controller for Wii

Trade Mark: Rock Candy

Model/Type reference: PL-8560C
Refer to page 5 for details.

Ratings: DC 3.0V

Responsible Engineer

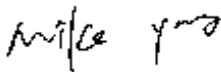

(Mike Yang/ Engineer)

Approved by

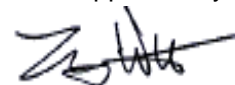

(Tomy Wu /EMC Manager)

TABLE OF CONTENTS

TEST REPORT DECLARE	4
1.Summary of test results.....	5
2.General test information.....	6
2.1 ACCRESITATIONS	6
2.2Description of EUT.....	6
2.3Accessories of EUT	6
2.4Assistant equipment used for test	6
2.5Block diagram of EUT configuration for test	6
2.6Test environment conditions	7
2.7Measurement uncertainty	7
3.Maximum Peak Output Power.....	8
3.1Test equipment.....	8
3.2Block diagram of test setup	8
3.3Limits.....	8
3.4Test Procedure	8
3.5Test Result	9
4.20dB Bandwidth	11
4.1Test equipment.....	11
4.2Block diagram of test setup	11
4.3Limits.....	11
4.4Test Procedure	11
4.5Test Result	12
4.6Original test data	12
5.Carrier Frequency Separation	14
5.1Test equipment.....	14
5.2Block diagram of test setup	14
5.3Limits.....	14
5.4Test Procedure	14
5.5Test Result	15
5.6Original test data	15
6.Number Of Hopping Channel	16
6.1Test equipment.....	16
6.2Block diagram of test setup	16
6.3Limits.....	16
6.4Test Procedure	16
6.5Test Result	16

6.6Original test data	17
7.Dwell Time.....	18
7.1Test equipment.....	18
7.2Block diagram of test setup	18
7.3Limits.....	18
7.4Test Procedure	18
7.5Test Result.....	18
7.6Original test data	18
8.Radiated emission.....	20
8.1Test equipment.....	20
8.2Block diagram of test setup	20
8.3Limit.....	21
8.4Test Procedure	22
8.5Test result.....	23
9.Band Edge Compliance.....	28
9.1Test equipment.....	28
9.2Block diagram of test setup	28
9.3Limit.....	28
9.4Test Procedure	29
9.5Test result.....	29
10.CONDUCTED SPURIOUS EMISSIONS.....	34
10.1. Test Equipment.....	34
10.2. Limit	34
10.3. Test Procedure.....	34
10.4. Test result	34
11.Antenna Requirements	41
11.1Limit.....	41
11.2Result.....	41
12.RF Exposure	42
13.Test setup photograph	43
14.Photos of the EUT.....	44

TEST REPORT DECLARE

Applicant	:	Performance Designed Products,LLC
Address	:	14144 Ventura Blvd, Suite 200 Sherman Oaks, CA 91423 U.S.A
Equipment under Test	:	RockCandy Wireless Controller for Wii
Model No	:	PL-8560C
Trade Mark	:	Rock Candy
Manufacturer	:	Performance Designed Products,LLC
Address	:	14144 Ventura Blvd, Suite 200 Sherman Oaks, CA 91423 U.S.A

Test Standard Used: FCC Rules and Regulations Part 15 Subpart C: 2010

Test procedure used: ANSI C63.10:2009
FCC Public Notice DA 00-705

FCC ID:X5B-PL8560C

We Declare:

The equipment described above is tested by ATT Product Service Co., Ltd. and in the configuration tested the equipment complied with the standards specified above. The test results are contained in this test report and ATT Product Service Co., Ltd. is assumed of full responsibility for the accuracy and completeness of these tests.

After test and evaluation, our opinion is that the equipment provided for test compliance with the requirement of the above FCC standards.

Report No:	13EAB08035 41		
Date of Test:	2013-8-15—2013-8-20	Date of Report:	2013-08-21

Note: This report applies to above tested sample only. This report shall not be reproduced in parts without written approval of ATT Product Service Co., Ltd.

1.Summary of test results

Description of Test Item	Standard	Results
Maximum Peak Output Power	15.247(b)(1) ANSI C63.10 :2009	PASS
20dB Bandwidth	15. 247(a)(1) ANSI C63.10 :2009	PASS
Carrier Frequency Separation	15.247(a)(1) ANSI C63.10 :2009	PASS
Number Of Hopping Channel	15.247(a)(1)(iii) ANSI C63.10 :2009	PASS
Dwell Time	15.247(a)(1)(iii) ANSI C63.10 :2009	PASS
Radiated Emission	15.209 15.247(d) ANSI C63.10 :2009	PASS
Band Edge Compliance	15.247(d) ANSI C63.10 :2009	PASS
Power Line Conducted Emissions	15.207 ANSI C63.10 :2009	NA
Antenna requirement	15.203	PASS
RF Exposure	15.247(i) 1.1310&2.1093	PASS

2.General test information

2.1 ACCREDITATIONS

The measuring facility of laboratories has been authorized or registered by the following approval agencies.

USA **FCC** **Registration Number :923232**
Canada **INDUSTRY CANADA** **Registration Number :11033A**

2.2Description of EUT

EUT* Name	:	RockCandy Wireless Controller for Wii
Model Number	:	PL-8560C
Trade Mark	:	Rock Candy
EUT function description	:	Please reference user manual of this device
Power supply	:	DC 3.0V
Radio Specification	:	Bluetooth V2.0
Operation frequency	:	2402MHz -2480MHz
Modulation	:	GFSK,
Data rate	:	1Mbps, 2Mbps, 3Mbps
Antenna Type	:	built-in "F" shape PCB antenna, maximum PK gain:0.81dBi
Date of Receipt	:	2013-08-21
Sample Type	:	Series production

Note: EUT is the ab. of equipment under test.

This is a standard bluetooth device, using a standard bluetooth technology.

2.3Accessories of EUT

Description of Accessories	Manufacturer	Model number or Type	Other
/	/	/	/

2.4Assistant equipment used for test

Description of Assistant equipment	Manufacturer	Model number or Type	Other
PC	Lenovo	E R500	/

2.5Block diagram of EUT configuration for test

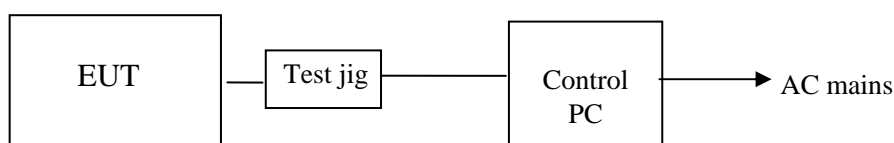

EUT's Bluetooth module was connected to a special test jig provided by manufacturer which has a standard RSS-232 connector to connect to control PC, and the control PC will run a special test software

"RF Control Kit v1.0.exe" provided by manufacturer to control EUT work in test mode as blow table.

Tested mode, channel, information		
Mode	Channel	Frequency (MHz)
GFSK hopping on Tx Mode	CH0 to CH78	2402 to 2480
GFSK hopping off Tx Mode	CH0	2402
	CH39	2441
	CH78	2480

Note1: Some modes not apply for all the test items.

2.6 Test environment conditions

During the measurement the environmental conditions were within the listed ranges:

Temperature range:	21-25°C
Humidity range:	40-75%
Pressure range:	86-106kPa

2.7 Measurement uncertainty

Test Item	Uncertainty
Uncertainty for Conduction emission test	2.44dB
Uncertainty for Radiation Emission test (150KHz-30MHz)	3.21dB
Uncertainty for Radiation Emission test (30MHz-1GHz)	3.14 dB (Polarize: V)
	3.16 dB (Polarize: H)
Uncertainty for Radiation Emission test (1GHz to 25GHz)	2.08dB(Polarize: V)
	2.56dB (Polarize: H)
Uncertainty for radio frequency	1×10 ⁻⁹
Uncertainty for conducted RF Power	0.65dB

Note: This uncertainty represents an expanded uncertainty expressed at approximately the 95% confidence level using a coverage factor of k=2.

3. Maximum Peak Output Power

3.1 Test equipment

Item	Equipment	Manufacturer	Model No.	Serial No.	Last Cal.	Cal. Interval
1	Spectrum analyzer	Agilent	E4407B	US40240708	2013/07/18	1Y
2	Attenuator	Mini-Circuits	BW-S10W2	101109	2012/12/28	1Y
3	RF Cable	Micable	C10-01-01-1	100309	2012/12/28	1Y

3.2 Block diagram of test setup

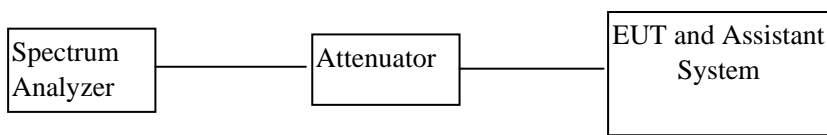

3.3 Limits

For frequency hopping systems operating in the 2400-2483.5 MHz band employing at least 75 non-overlapping hopping channels, and all frequency hopping systems in the 5725-5850 MHz band: 1 watt. For all other frequency hopping systems in the 2400-2483.5 MHz band: 0.125 watts, the e.i.r.p shall not exceed 4W.

3.4 Test Procedure

- (1) Configure EUT and assistant system according clause 2.4 and 3.2
- (2) Connect EUT's antenna output to spectrum analyzer by RF cable and though a 10dB attenuator.
- (3) Configure EUT work in test mode as stated in clause 2.4.

Measure the maximum output power of EUT by spectrum analyzer with PK detector and RBW=1MHz, VBW=3MHz , Span=5MHz, Sweep time=auto, Trace=max hold.

Note: The attenuator loss was inputted into spectrum analyzer as amplitude offset.

3.5 Test Result

EUT: RockCandy Wireless Controller for Wii M/N: PL-8560C				
Mode	Freq (MHz)	Result (dBm)	Limit (dBm)	Conclusion
GFSK	2402	2.30	30	PASS
	2441	1.57	30	PASS
	2480	1.08	30	PASS
Test Date : 2013-08-15			Test Engineer : Mike Yang	

GFSK:

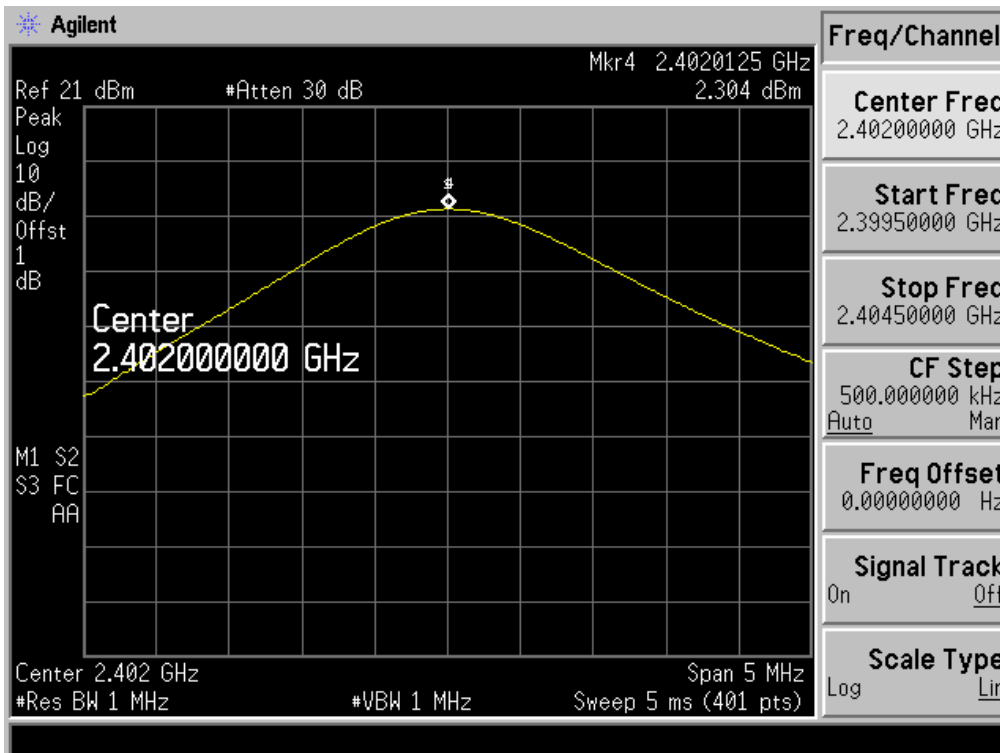

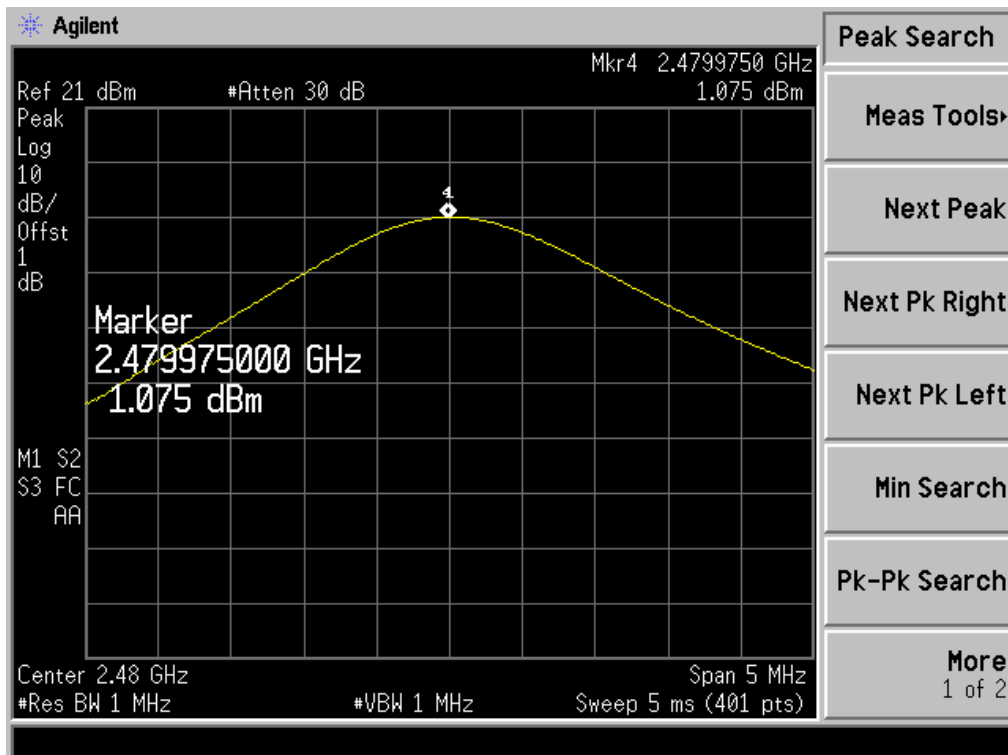
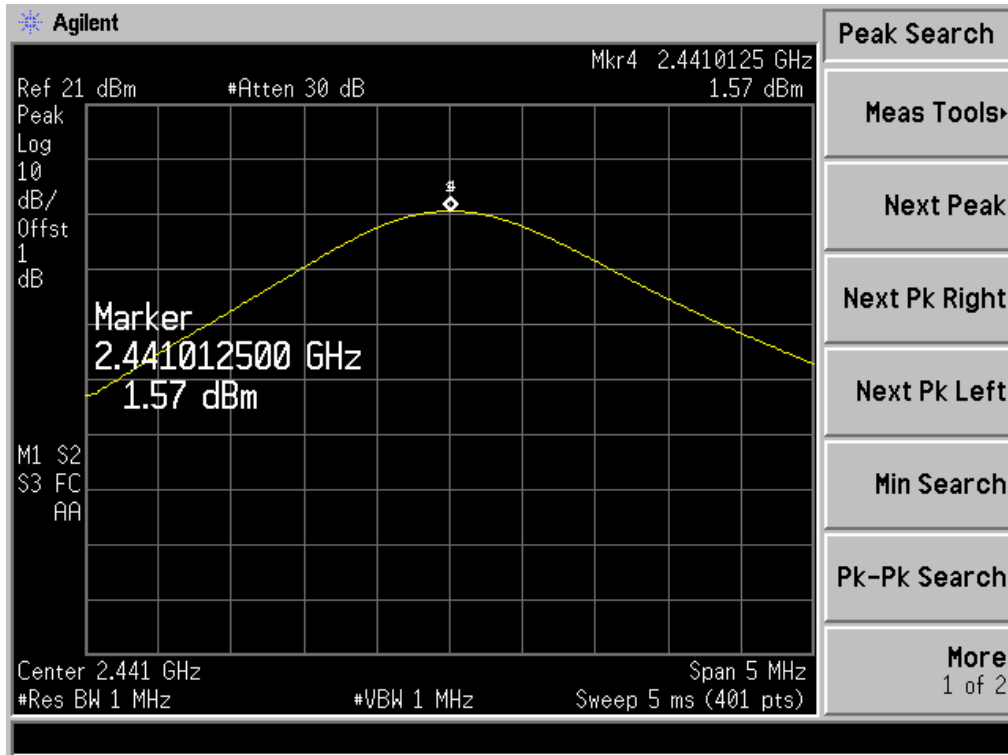

4.20dB Bandwidth

4.1 Test equipment

Item	Equipment	Manufacturer	Model No.	Serial No.	Last Cal.	Cal. Interval
1	Spectrum analyzer	Agilent	E4407B	US40240708	2013/07/18	1Y
2	Attenuator	Mini-Circuits	BW-S10W2	101109	2012/12/28	1Y
3	RF Cable	Micable	C10-01-01-1	100309	2012/12/28	1Y

4.2 Block diagram of test setup

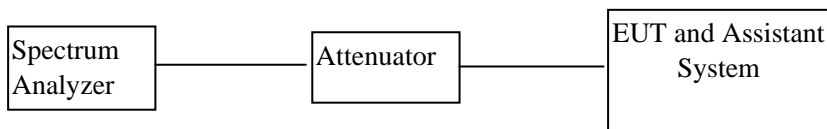

4.3 Limits

Intentional radiators operating under the alternative provisions to the general emission limits, as contained in § 15.217 through 15.257 and in Subpart E of this part, must be designed to ensure that the 20 dB bandwidth of the emission, or whatever bandwidth may otherwise be specified in the specific rule section under which the equipment operates, is contained within the frequency band designated in the rule section under which the equipment is operated.

4.4 Test Procedure

- (1) Configure EUT and assistant system according clause 2.4 and 4.2
- (2) Connect EUT's antenna output to spectrum analyzer by RF cable and through a 10dB attenuator.
- (3) Configure EUT work in test mode as stated in clause 2.4.
- (4) The bandwidth of the fundamental frequency was measured by spectrum analyzer with RBW =30kHz and VBW =100kHz.,Span=3MHz,Sweep time=auto
- (5) The 20dB bandwidth is defined as the total spectrum the power of which is higher than peak power minus 20dB.

4.5 Test Result

EUT: RockCandy Wireless Controller for Wii M/N: PL-8560C					
Mode	Freq (MHz)	Result (MHz)	Limit (MHz)	Margin (MHz)	Conclusion
GFSK	2402	0.895	/	/	PASS
	2441	0.913	/	/	PASS
	2480	0.918	/	/	PASS
Test Date : 2013-8-15			Test Engineer : Mike Yang		

4.6 Original test data

GFSK Mode

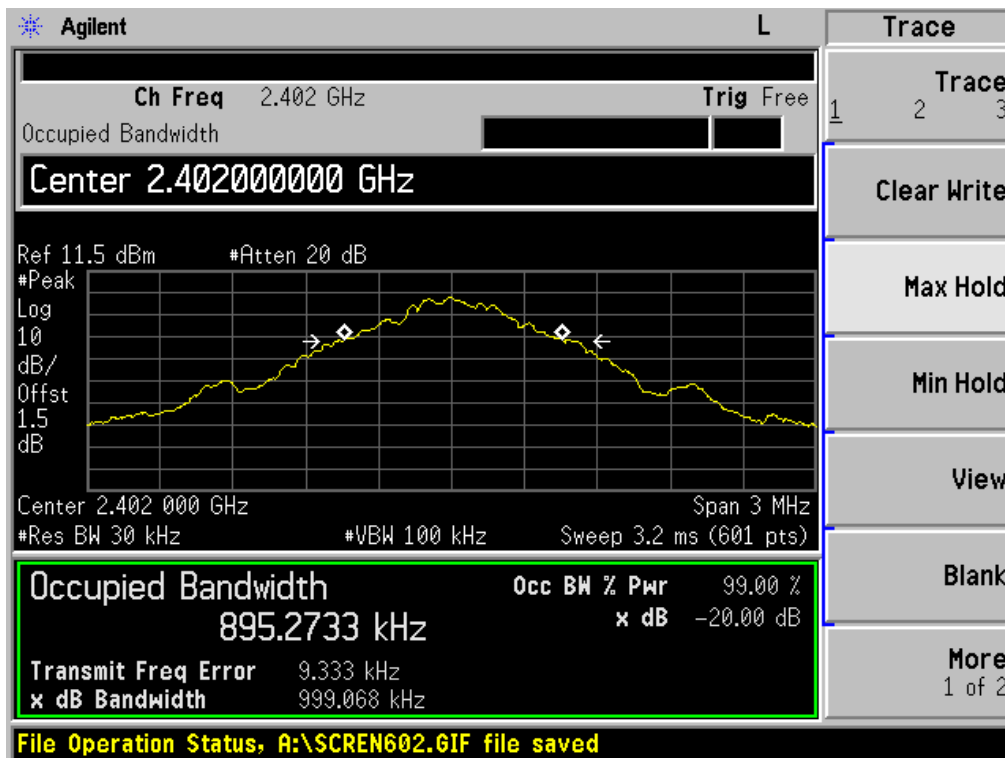

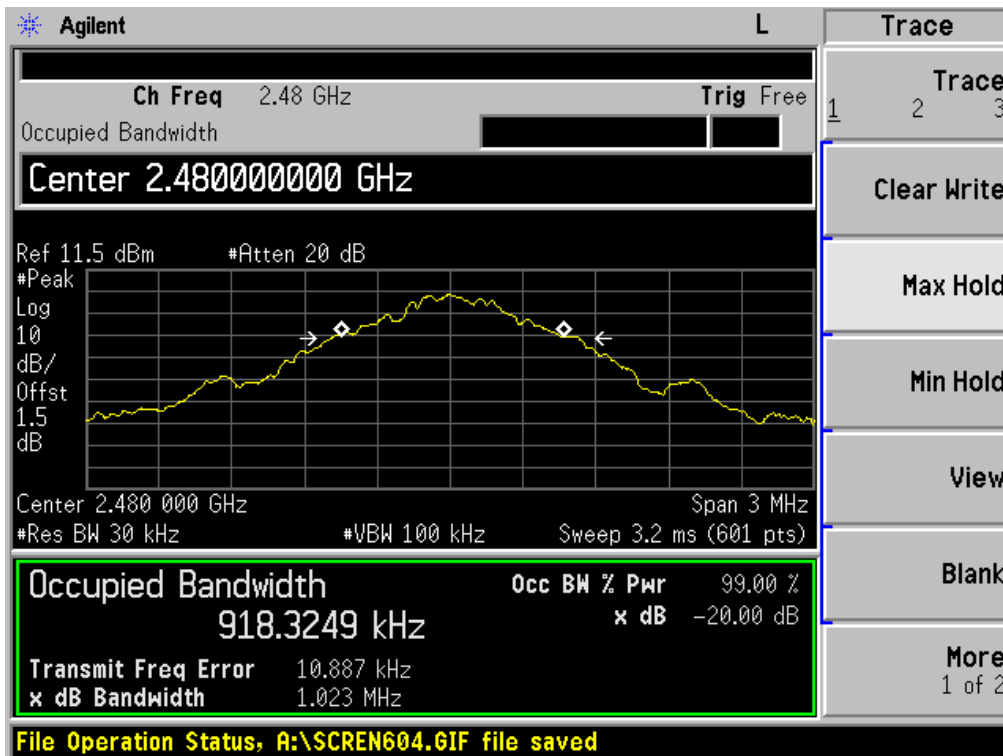
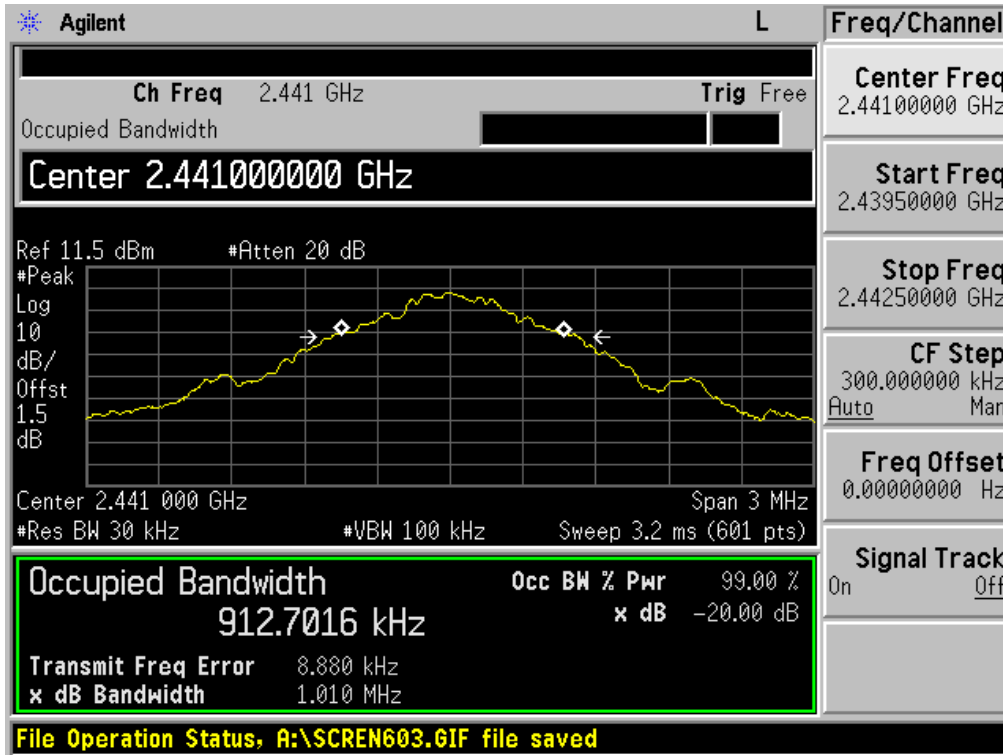

5. Carrier Frequency Separation

5.1 Test equipment

Item	Equipment	Manufacturer	Model No.	Serial No.	Last Cal.	Cal. Interval
1	Spectrum analyzer	Agilent	E4407B	US40240708	2013/07/18	1Y
2	Attenuator	Mini-Circuits	BW-S10W2	101109	2012/12/28	1Y
3	RF Cable	Micable	C10-01-01-1	100309	2012/12/28	1Y

5.2 Block diagram of test setup

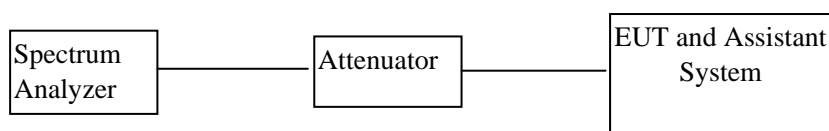

5.3 Limits

Frequency hopping systems shall have hopping channel carrier frequencies separated by a minimum of 25 kHz or the 20 dB bandwidth of the hopping channel, whichever is greater. Alternatively, frequency hopping systems operating in the 2400-2483.5 MHz band may have hopping channel carrier frequencies that are separated by 25 kHz or two-thirds of the 20 dB bandwidth of the hopping channel, whichever is greater, provided the systems operate with an output power no greater than 125 mW.

5.4 Test Procedure

- (1) Configure EUT and assistant system according clause 2.4 and 5.2
- (2) Connect EUT's antenna output to spectrum analyzer by RF cable and through a 10dB attenuator.
- (3) Configure EUT work in test mode as stated in clause 2.4.
- (4) The carrier frequency was measured by spectrum analyzer with 30kHz RBW and 100kHz VBW.

5.5 Test Result

EUT: RockCandy Wireless Controller for Wii M/N: PL-8560C				
Mode	Channel separation (MHz)	20dB Bandwidth (MHz)	Limit (MHz) 2/3 of 20dB bandwidth	Conclusion
GFSK	1.0	0.918	0.612	PASS
Test Date :2013-8-16			Test Engineer : Mike Yang	

5.6 Original test data

GFSK

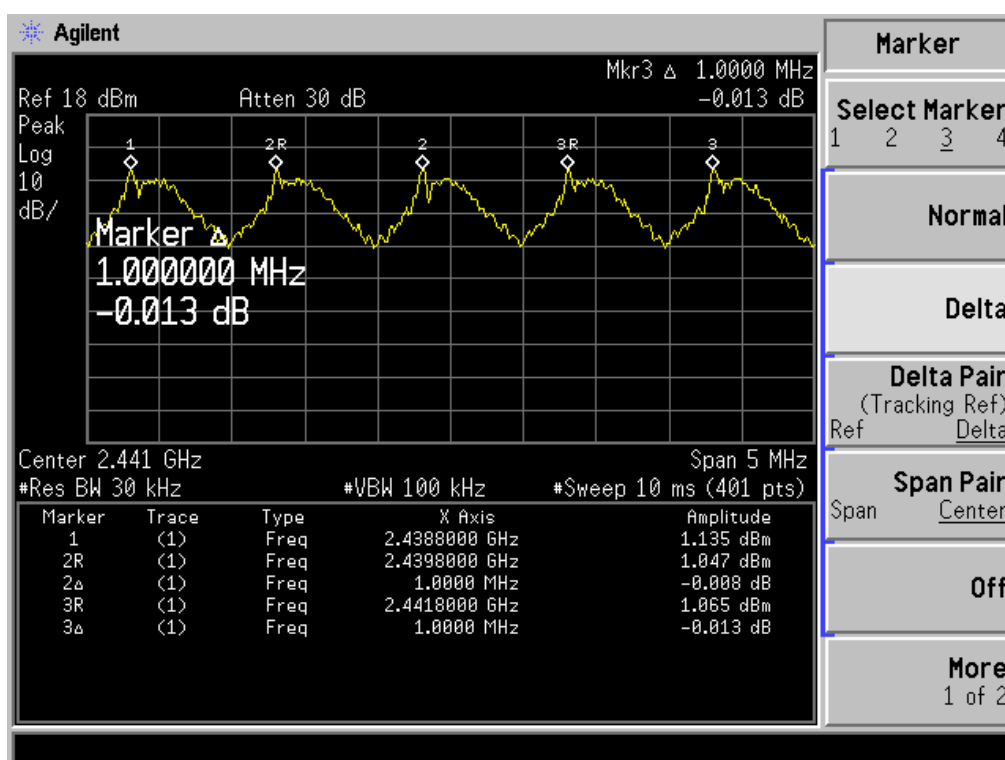

6.Number Of Hopping Channel

6.1Test equipment

Item	Equipment	Manufacturer	Model No.	Serial No.	Last Cal.	Cal. Interval
1	Spectrum analyzer	Agilent	E4407B	US40240708	2013/07/18	1Y
2	Attenuator	Mini-Circuits	BW-S10W2	101109	2012/12/28	1Y
3	RF Cable	Micable	C10-01-01-1	100309	2012/12/28	1Y

6.2Block diagram of test setup

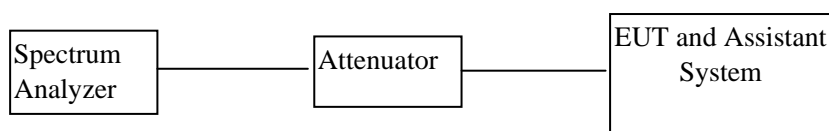

6.3Limits

Frequency hopping systems in the 2400-2483.5 MHz band shall use at least 15 channels.

6.4Test Procedure

- (1) Configure EUT and assistant system according clause 2.4 and 6.2
- (2) Connect EUT's antenna output to spectrum analyzer by RF cable and though a 10dB attenuator.
- (3) Configure EUT work in test mode as stated in clause 2.4.
- (4) The number of hopping channel was measured by spectrum analyzer with 300 kHz RBW and 1MHz VBW.

6.5Test Result

EUT: RockCandy Wireless Controller for Wii M/N: PL-8560C			
Mode	Number of hopping channel	Limit	Conclusion
GFSK	79	>15	PASS
Test Date : 2013-8-16		Test Engineer : Mike Yang	

6.6 Original test data

GFSK:

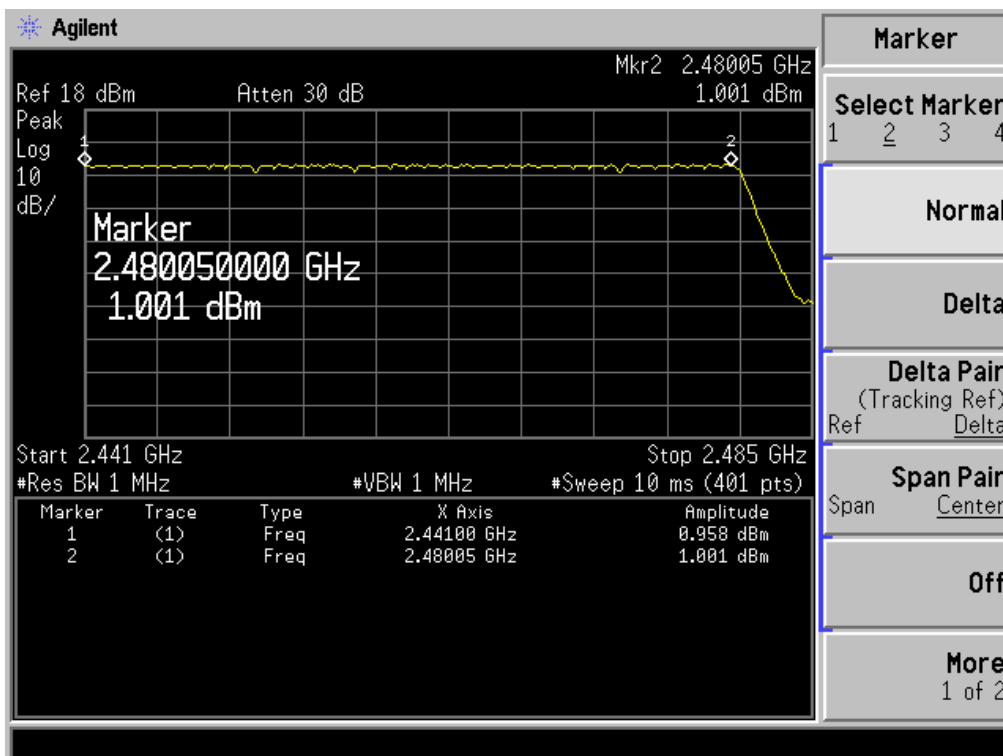
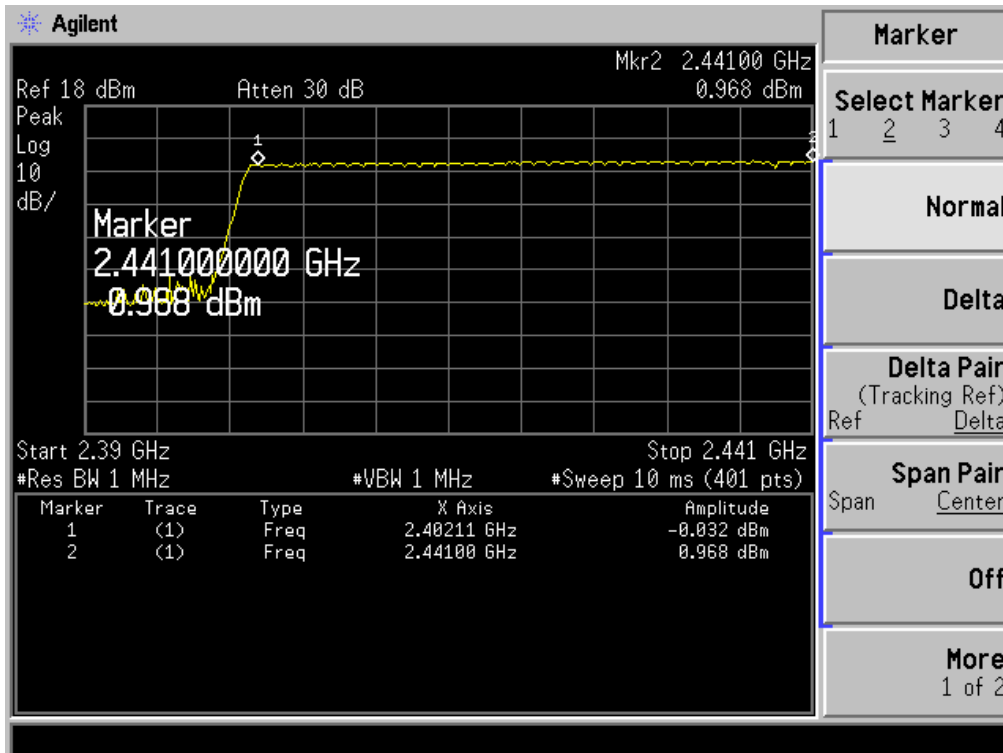

7.Dwell Time

7.1 Test equipment

Item	Equipment	Manufacturer	Model No.	Serial No.	Last Cal.	Cal. Interval
1	Spectrum analyzer	Agilent	E4407B	US40240708	2013/07/18	1Y
2	Attenuator	Mini-Circuits	BW-S10W2	101109	2012/12/28	1Y
3	RF Cable	Micable	C10-01-01-1	100309	2012/12/28	1Y

7.2 Block diagram of test setup

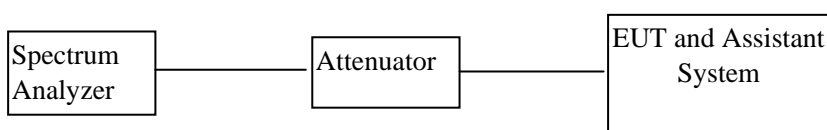

7.3 Limits

The average time of occupancy on any channel shall not be greater than 0.4 seconds within a period of 0.4 seconds multiplied by the number of hopping channels employed.

7.4 Test Procedure

- (1) Configure EUT and assistant system according clause 2.4 and 7.2
- (2) Connect EUT's antenna output to spectrum analyzer by RF cable and through a 10dB attenuator.
- (3) Configure EUT work in test mode as stated in clause 2.4.
- (4) Measure the hopping number and on time of each pulse with spectrum analyzer in zero span set, and calculate dwell time with formula $Dwell\ time = Hopping\ number / measure\ time * 0.4 * 79 * pulse's\ on\ time$

7.5 Test Result

EUT: RockCandy Wireless Controller for Wii M/N: PL-8560C			
Mode	Number of hopping channel	Limit	Conclusion
DH1	133.51ms	<400ms	PASS
Test Date : 2013-8-16		Test Engineer : Mike Yang	

Note: DH1 mode only, no DH3&DH5

7.6 Original test data

$$DH1: 50/5s * 0.4 * 79 * 0.4225 = 133.51ms$$

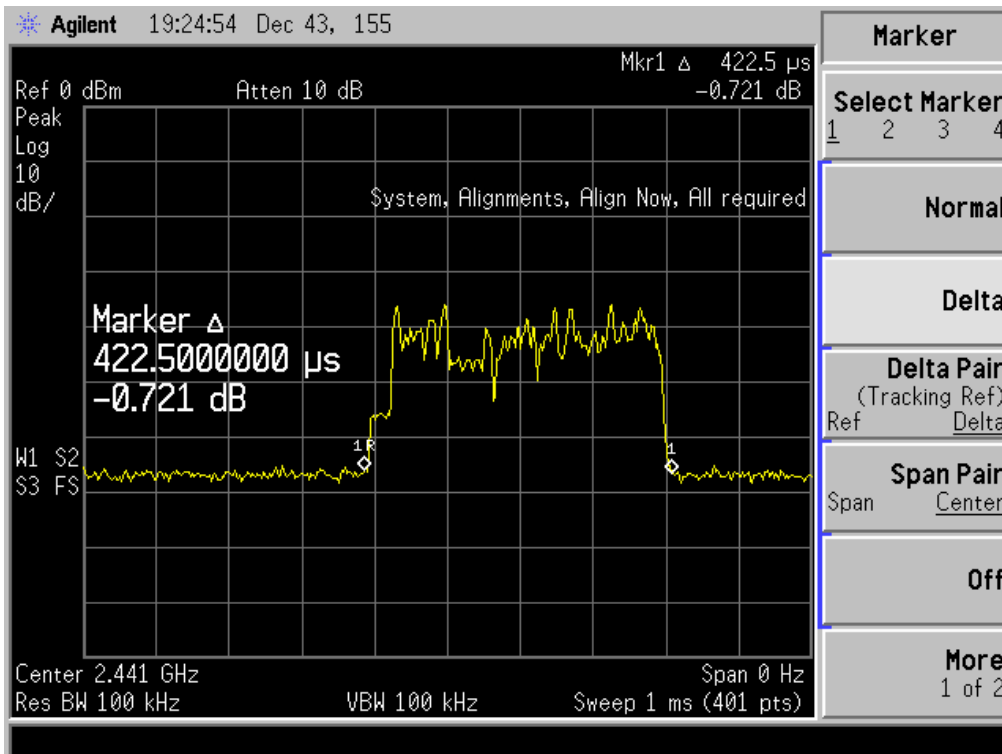
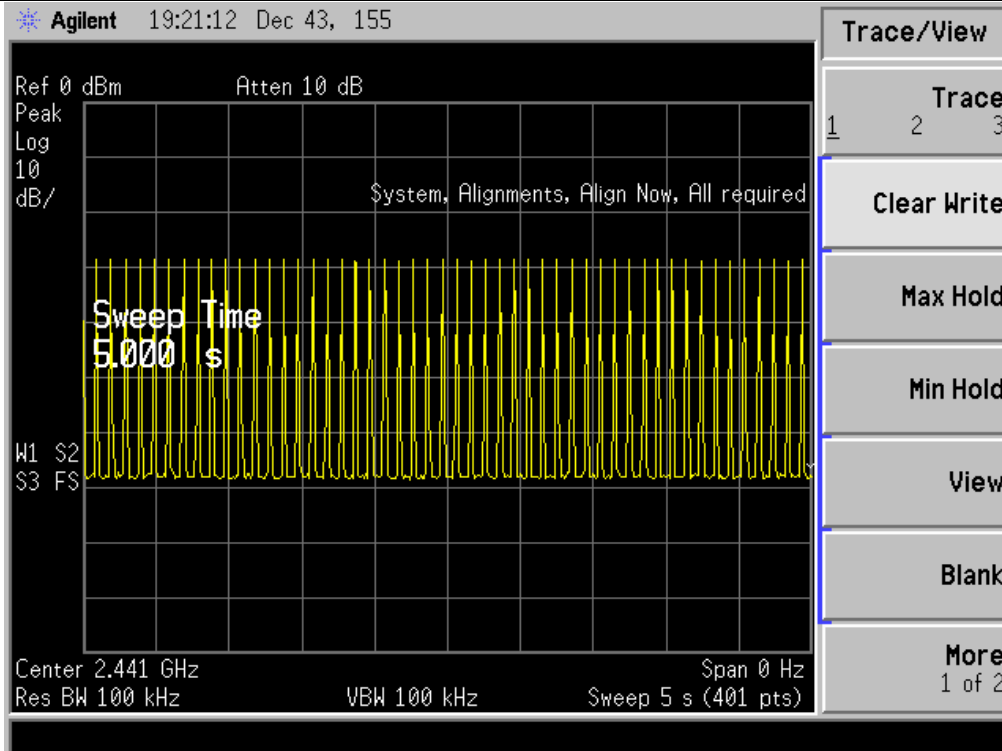

8. Radiated emission

8.1 Test equipment

Item	Equipment	Manufacturer	Model No.	Serial No.	Last Cal.	Cal. Interval
1	EMI Test Receiver	R&S	ESU8	100316	2012/11/26	1Y
2	Spectrum analyzer	Agilent	E4407B	US40240708	2013/07/18	1Y
3	Loop antenna	Chase	HLA6120	20129	2012/12/28	1Y
4	Trilog Broadband Antenna	Schwarzbeck	VULB9163	9163-462	2012/12/28	1Y
5	Double Ridged Horn Antenna	R&S	HF907	100276	2012/12/28	1Y
6	Pre-Amplifier	R&S	SCU-01	10049	2012/12/28	1Y
7	Pre-amplifier	A.H.	PAM0-0118	360	2012/12/28	1Y
8	RF Cable	R&S	R01	10403	2012/12/28	1Y
9	RF Cable	R&S	R02	10512	2012/12/28	1Y
10	Horn Antenna	EMCO	3116	9608-4877	2012/12/28	1Y

8.2 Block diagram of test setup

In 3m Anechoic Chamber Test Setup Diagram for below 1GHz

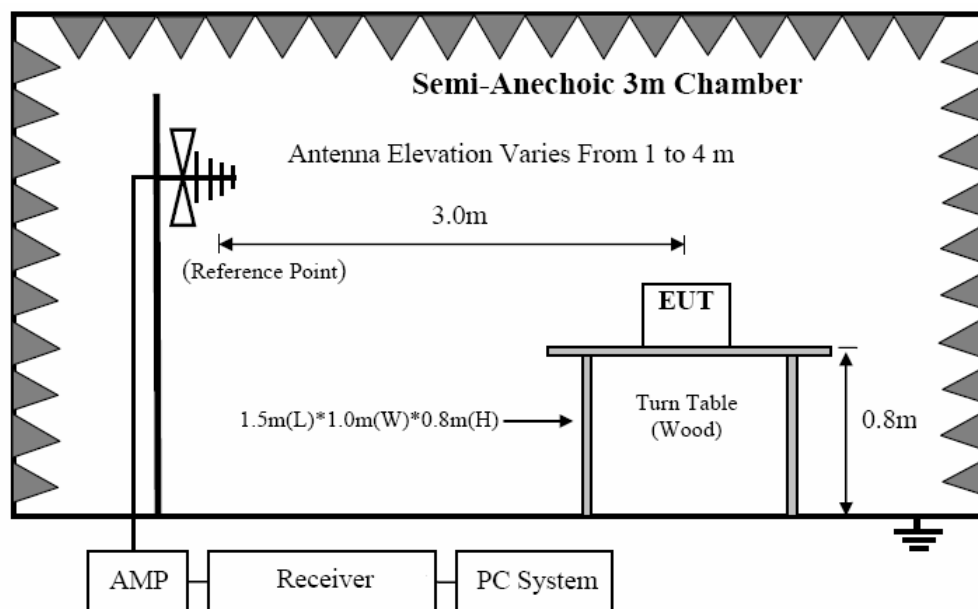

In 3m Anechoic Chamber Test Setup Diagram for frequency above 1GHz

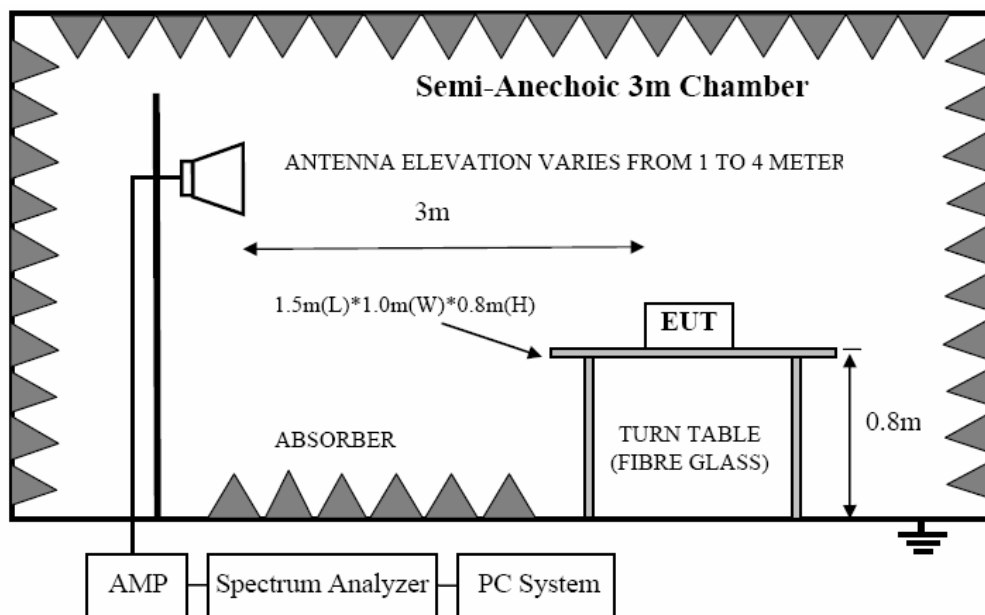

Note: For harmonic emissions test a appropriate high pass filter was inserted in the input port of AMP.

8.3Limit

8.3.1 FCC 15.205 Restricted frequency band

MHz	MHz	MHz	GHz
0.090 - 0.110	16.42 - 16.423	399.9 - 410	4.5 - 5.15
¹ 0.495 - 0.505	16.69475 - 16.69525	608 - 614	5.35 - 5.46
2.1735 - 2.1905	16.80425 - 16.80475	960 - 1240	7.25 - 7.75
4.125 - 4.128	25.5 - 25.67	1300 - 1427	8.025 - 8.5
4.17725 - 4.17775	37.5 - 38.25	1435 - 1626.5	9.0 - 9.2
4.20725 - 4.20775	73 - 74.6	1645.5 - 1646.5	9.3 - 9.5
6.215 - 6.218	74.8 - 75.2	1660 - 1710	10.6 - 12.7
6.26775 - 6.26825	108 - 121.94	1718.8 - 1722.2	13.25 - 13.4
6.31175 - 6.31225	123 - 138	2200 - 2300	14.47 - 14.5
8.291 - 8.294	149.9 - 150.05	2310 - 2390	15.35 - 16.2
8.362 - 8.366	156.52475 - 156.52525	2483.5 - 2500	17.7 - 21.4
8.37625 - 8.38675	156.7 - 156.9	2690 - 2900	22.01 - 23.12
8.41425 - 8.41475	162.0125 - 167.17	3260 - 3267	23.6 - 24.0
12.29 - 12.293	167.72 - 173.2	3332 - 3339	31.2 - 31.8
12.51975 - 12.52025	240 - 285	3345.8 - 3358	36.43 - 36.5
12.57675 - 12.57725	322 - 335.4	3600 - 4400	(²)

8.3.2 FCC 15.209 Limit

FREQUENCY MHz	DISTANCE Meters	FIELD STRENGTHS LIMIT	
		$\mu\text{V}/\text{m}$	$\text{dB}(\mu\text{V})/\text{m}$
30 ~ 88	3	100	40.0
88 ~ 216	3	150	43.5
216 ~ 960	3	200	46.0
960 ~ 1000	3	500	54.0
Above 1000	3	74.0 $\text{dB}(\mu\text{V})/\text{m}$ (Peak) 54.0 $\text{dB}(\mu\text{V})/\text{m}$ (Average)	

8.3.3 Limit for this EUT

All the emissions appearing within 15.205 restricted frequency bands shall not exceed the limits shown in 15.209, all the other emissions shall be at least 20dB below the fundamental emissions, or comply with 15.209 limits.

8.4 Test Procedure

- (1) EUT was placed on a non-metallic table, 80 cm above the ground plane inside a semi-anechoic chamber.
- (2) Setup EUT and assistant system according clause 2.4 and 8.2
- (3) Test antenna was located 3m from the EUT on an adjustable mast. Below pre-scan procedure was first performed in order to find prominent radiated emissions.
 - (a) Change work frequency or channel of device if practicable.
 - (b) Change modulation type of device if practicable.
 - (c) Change power supply range from 85% to 115% of the rated supply voltage
 - (d) Rotated EUT though three orthogonal axes to determine the attitude of EUT arrangement produces highest emissions
- (4) Spectrum frequency from 9MHz to 25GHz (tenth harmonic of fundamental frequency) was investigated, and no any obvious emission were detected from 9KHz to 30MHz and 18GHz to 25GHz, so below final test was performed with frequency range from 30MHz to 18GHz.
- (5) For final emissions measurements at each frequency of interest, the EUT were rotated and the antenna height was varied between 1m and 4m in order to maximize the emission. Measurements in both horizontal and vertical polarities were made and the data was recorded. In order to find the maximum emission, the relative positions of equipments and all of the interface cables were changed according to ANSI C63.10 2009 on Radiated Emission test.
- (6) For emissions from 30MHz to 1GHz, Quasi-Peak values were measured with EMI Receiver and the bandwidth of Receiver is 120 KHz.
- (7) For emissions above 1GHz, both Peak and Average level were measured with Spectrum Analyzer, and the RBW is set at 1MHz, VBW is set at 3MHz for Peak measure; RBW is set at 1MHz, VBW is set at 10Hz for Average measure.
- (8) For emissions below 1GHz, according explorer test, when change Tx mode and channel,

have no distinct influence on emissions level, so for emissions below 1GHz, the final test was only performed with EUT working in GFSK, Tx 2440MHz mode.

8.5 Test result

PASS. (See below detailed test result)

All the emissions except fundamental emission from 9KHz to 25GHz were comply with 15.209 limit.

The frequency range from 30MHz to 10th harmonic (25GHz) are checked. and no any emissions were found from 18GHz to 25 GHz, So the radiated emissions from 18GHz to 25GHz were not record.

Radiated Emission Test Result (Below 1GHz)

Test Mode:GFSK

Test Site	: 3m Chamber	Tested By	: Mike Yang
Test Date	: 2013-8-18	Model Number	: PL-8560C
EUT	: RockCandy Wireless Controller for Wii	Test Mode	: GFSK Tx mode CH39
Power Supply	: DC 3.0V	Antenna/Distance	: 3m/H
Condition	: Temp:24.5°C,Humi:55%		

No. Mk.	Freq.	Reading Level	Correct Factor	Measurement	Limit	Over	Antenna Height	Table Degree	
	MHz	dBuV	dB	dBuV/m	dB/m	dB	cm	degree	Comment
1	323.9100	45.46	-6.75	38.71	45.50	-6.79	QP		
2	! 359.8000	49.65	-6.56	43.09	45.50	-2.41	QP		
3	! 395.6899	47.62	-5.51	42.11	45.50	-3.39	QP		
4	* 540.2199	44.07	-0.83	43.24	45.50	-2.26	QP		
5	! 612.0000	41.08	-0.10	40.98	45.50	-4.52	QP		
6	! 756.5298	37.54	3.01	40.55	45.50	-4.95	QP		

Note: 1. Result Level = Read Level + Antenna Factor + Cable loss - PRM Factor
 2. If Peak Result comply with QP limit, QP Result is deemed to comply with QP limit

Test Site	: 3m Chamber	Tested By	: Mike Yang
Test Date	: 2013-8-18	Model Number	: PL-8560C
EUT	: RockCandy Wireless Controller for Wii	Test Mode	: GFSK Tx mode CH39
Power Supply	: DC 3.0V	Antenna/Distance	: 3m/V
Condition	: Temp:24.5°C,Humi:55%		

No. Mk.	Freq.	Reading Level	Correct Factor	Measurement	Limit	Over	Antenna Height	Table Degree	
	MHz	dBuV	dB	dBuV/m	dB/m	dB	cm	degree	Comment
1	* 191.0200	41.07	-7.87	33.20	43.00	-9.80	QP		
2	359.8000	39.06	-5.52	33.54	45.50	-11.96	QP		
3	480.0799	35.09	-2.41	32.68	45.50	-12.82	QP		
4	684.7500	29.39	1.89	31.28	45.50	-14.22	QP		
5	756.5298	30.59	3.01	33.60	45.50	-11.90	QP		
6	395.6899	38.59	-5.51	33.08	45.50	-12.42	QP		

Note: 1. Result Level = Read Level + Antenna Factor + Cable loss - PRM Factor
 2. If Peak Result comply with QP limit, QP Result is deemed to comply with QP limit

Radiated Emission Test Result (Above 1GHz)

Test Mode:GFSK

Test Site	: 3m Chamber	Tested By	: Mike Yang
Test Date	: 2013-08-16	Model Number	: PL-8560C
EUT	: RockCandy Wireless Controller for wii	Test Mode	: GFSK Tx mode CH0
Power Supply	: DC 3V	Antenna/Distance	: 3m/V
Condition	: Temp:24.5°C,Humi:55%		

No.	Frequency (MHz)	Reading (dBuV/m)	Correct Factor(dB/m)	Result (dBuV/m)	Limit (dBuV/m)	Margin (dB)	Remark
1	2402.150	94.62	2.26	96.88			
2	4804.630	59.37	8.12	67.49	74.00	-6.51	peak
3	4804.630	40.08	8.12	48.20	54.00	-5.80	AVG

Note: 1. Result Level = Read Level + Antenna Factor + Cable loss - PRM Factor
 2. If Peak Result comply with QP limit, QP Result is deemed to comply with QP limit

Test Site	: 3m Chamber	Tested By	: Mike Yang
Test Date	: 2013-08-16	Model Number	: PL-8560C
EUT	: RockCandy Wireless Controller for wii	Test Mode	: GFSK Tx mode CH0
Power Supply	: DC 3V	Antenna/Distance	: 3m/H
Condition	: Temp:24.5°C,Humi:55%		

No.	Frequency (MHz)	Reading (dBuV/m)	Correct Factor(dB/m)	Result (dBuV/m)	Limit (dBuV/m)	Margin (dB)	Remark
1	2402.150	92.38	2.26	94.64			
2	4804.560	59.22	8.12	67.34	74.00	-6.66	peak
3	4800.000	40.36	8.12	48.48	54.00	-5.52	AVG

Note: 1. Result Level = Read Level + Antenna Factor + Cable loss - PRM Factor
 2. If Peak Result comply with QP limit, QP Result is deemed to comply with QP limit

Test Site : 3m Chamber
Test Date : 2013-08-16
EUT : RockCandy Wireless Controller for wii
Power Supply : DC 3V
Condition : Temp:24.5°C,Humi:55%
Tested By : Mike Yang
Model Number : PL-8560C
Test Mode : GFSK Tx mode CH39
Antenna/Distance : 3m/H

No.	Frequency (MHz)	Reading (dBuV/m)	Correct Factor(dB/m)	Result (dBuV/m)	Limit (dBuV/m)	Margin (dB)	Remark
1	2441.230	93.52	2.32	95.84			
2	4887.500	40.28	8.20	48.48	54.00	-5.52	AVG
3	4887.500	57.86	8.20	66.06	74.00	-7.94	peak

Note: 1. Result Level = Read Level + Antenna Factor + Cable loss - PRM Factor
 2. If Peak Result comply with QP limit, QP Result is deemed to comply with QP limit

Test Site : 3m Chamber
Test Date : 2013-08-16
EUT : RockCandy Wireless Controller for wii
Power Supply : DC 3V
Condition : Temp:24.5°C,Humi:55%
Tested By : Mike Yang
Model Number : PL-8560C
Test Mode : GFSK Tx mode CH39
Antenna/Distance : 3m/V

No.	Frequency (MHz)	Reading (dBuV/m)	Correct Factor(dB/m)	Result (dBuV/m)	Limit (dBuV/m)	Margin (dB)	Remark
1	2441.260	90.68	2.32	93.00			
2	4887.500	40.50	8.20	48.70	54.00	-5.30	AVG
3	4887.500	58.60	8.20	66.80	74.00	-7.20	peak

Note: 1. Result Level = Read Level + Antenna Factor + Cable loss - PRM Factor
 2. If Peak Result comply with QP limit, QP Result is deemed to comply with QP limit

Test Site : 3m Chamber
Test Date : 2013-08-16 **Tested By** : Mike Yang
EUT : RockCandy Wireless Controller for wii **Model Number** : PL-8560C
Power Supply : DC 3V **Test Mode** : GFSK Tx mode CH78
Condition : Temp:24.5°C,Humi:55% **Antenna/Distance** : 3m/V

No.	Frequency (MHz)	Reading (dBuV/m)	Correct Factor(dB/m)	Result (dBuV/m)	Limit (dBuV/m)	Margin (dB)	Remark
1	2480.000	94.28	2.38	96.66			
2	4962.500	59.16	8.27	67.43	74.00	-6.57	peak
3	4962.500	40.11	8.27	48.38	54.00	-5.62	AVG

Note: 1. Result Level = Read Level + Antenna Factor + Cable loss - PRM Factor
 2. If Peak Result comply with QP limit, QP Result is deemed to comply with QP limit

Test Site : 3m Chamber
Test Date : 2013-08-16 **Tested By** : Mike Yang
EUT : RockCandy Wireless Controller for wii **Model Number** : PL-8560C
Power Supply : DC 3V **Test Mode** : GFSK Tx mode CH78
Condition : Temp:24.5°C,Humi:55% **Antenna/Distance** : 3m/H

No.	Frequency (MHz)	Reading (dBuV/m)	Correct Factor(dB/m)	Result (dBuV/m)	Limit (dBuV/m)	Margin (dB)	Remark
1	2480.000	91.23	2.38	93.61			
2	4962.500	59.73	8.27	68.00	74.00	-6.00	peak
3	4962.500	40.36	8.27	48.63	54.00	-5.37	AVG

Note: 1. Result Level = Read Level + Antenna Factor + Cable loss - PRM Factor
 2. If Peak Result comply with QP limit, QP Result is deemed to comply with QP limit

9. Band Edge Compliance

9.1 Test equipment

Item	Equipment	Manufacturer	Model No.	Serial No.	Last Cal.	Cal. Interval
1	EMI Test Receiver	R&S	ESU8	100316	2012/11/26	1Y
2	Spectrum analyzer	Agilent	E4407B	US40240708	2013/07/18	1Y
3	Trilog Broadband Antenna	Schwarzbeck	VULB9163	9163-462	2012/12/28	1 Y
4	Double Ridged Horn Antenna	R&S	HF907	100276	2012/12/28	1 Y
5	Pre-Amplifier	R&S	SCU-01	10049	2012/12/28	1Y
6	Pre-amplifier	A.H.	PAM0-0118	360	2012/12/28	1Y
7	RF Cable	R&S	R01	10403	2012/12/28	1Y
8	RF Cable	R&S	R02	10512	2012/12/28	1Y

9.2 Block diagram of test setup

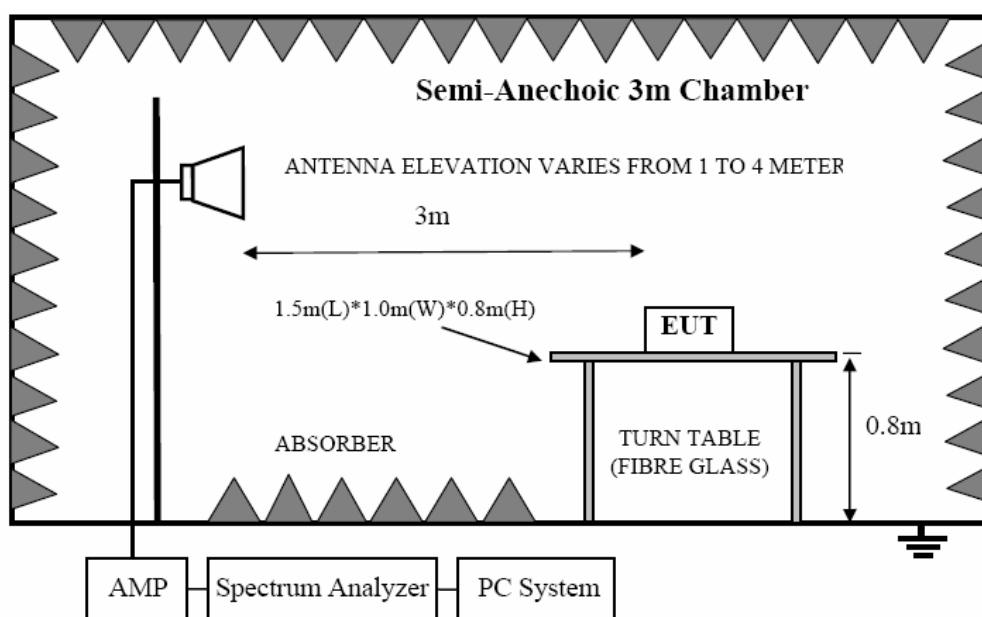

9.3 Limit

All the lower and upper band-edges emissions appearing within 2310MHz to 2390MHz and 2483.5MHz to 2500MHz restricted frequency bands shall not exceed the limits shown in 15.209, all the other emissions outside operation frequency band 2400MHz to 2483.5MHz and 5725MHz to 5850MHz shall be at least 20dB below the fundamental emissions, or comply with 15.209 limits.

9.4 Test Procedure

Same with clause 8.4 except change investigated frequency range from 2310MHz to 2415MHz and 2475MHz to 2500MHz.

9.5 Test result

PASS. (See below detailed test result)

Band edge Test Result

Test Site	: 3m Chamber	Tested By	: Mike Yang
Test Date	: 2013-08-16	Model Number	: PL-8560C
EUT	: RockCandy Wireless Controller for Wii	Test Mode	: GFSK Hopping on
Power Supply	: DC 3V	Antenna	: H
Condition	: Temp:24.5'C,Humi:55%		

Data : 45

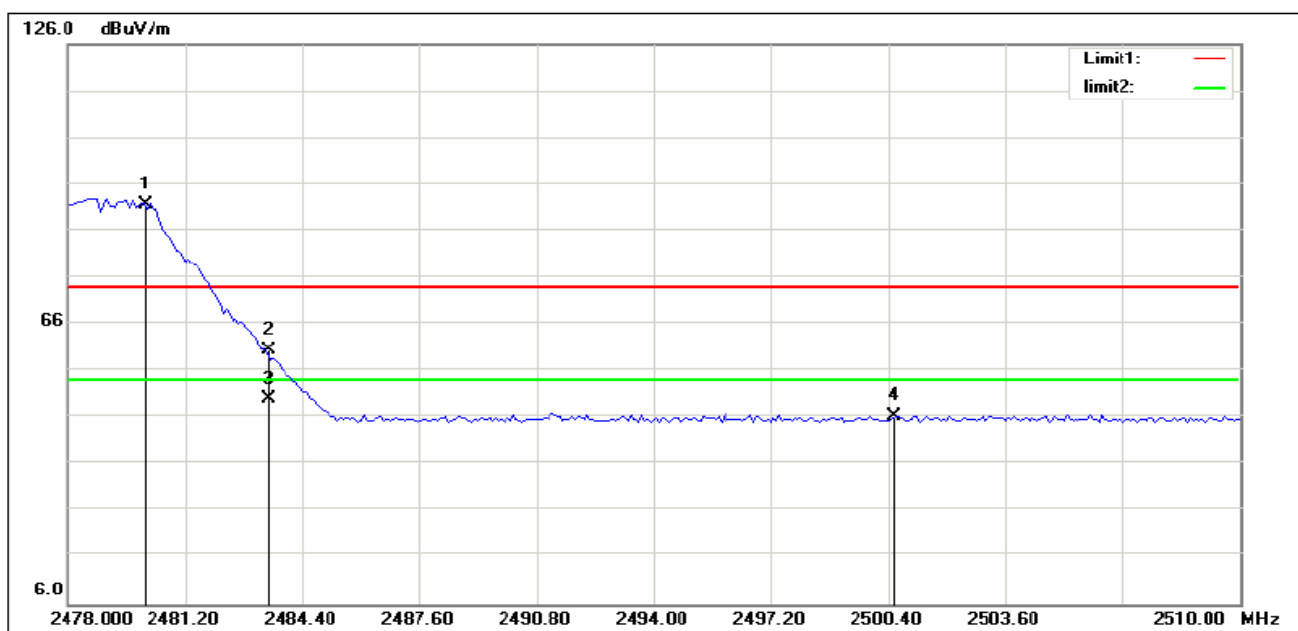

No.	Frequency (MHz)	Reading (dBuV/m)	Correct Factor(dB/m)	Result (dBuV/m)	Limit (dBuV/m)	Margin (dB)	Remark
1	2480.130	91.25	0.31	91.56	74.00	17.56	peak
2	2483.500	60.19	0.33	60.52	74.00	-13.48	peak
3	2483.500	49.65	0.33	49.98	54.00	-4.02	AVG
4	2500.551	46.06	0.35	46.41	74.00	-27.59	peak

Note: 1. Result Level = Read Level + Antenna Factor + Cable loss - PRM Factor
 2. If Peak Result comply with AV limit, AV Result is deemed to comply with AV limit

Band edge Test Result

Test Site : 3m Chamber
Test Date : 2013-08-16 **Tested By** : Mike Yang
EUT : RockCandy Wireless Controller for Wii **Model Number** : PL-8560C
Power Supply : DC 3V **Test Mode** : GFSK Hopping on
Condition : Temp:24.5'C,Humi:55% **Antenna** : V

Data : 46

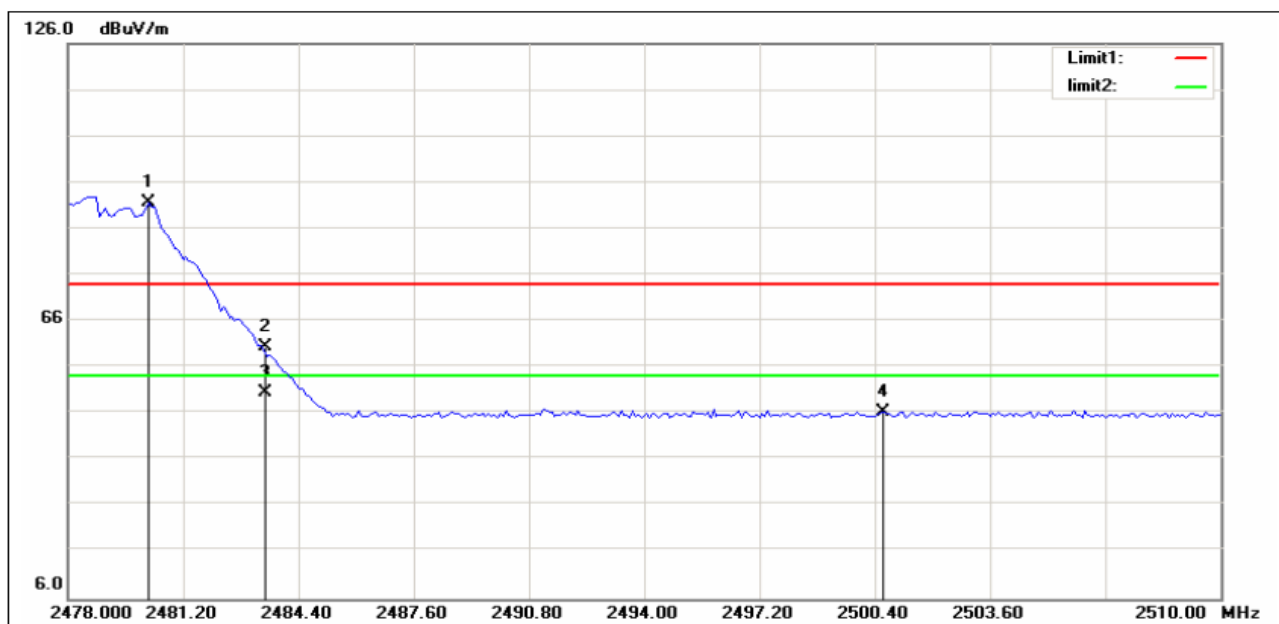

No.	Frequency (MHz)	Reading (dBuV/m)	Correct Factor(dB/m)	Result (dBuV/m)	Limit (dBuV/m)	Margin (dB)	Remark
1	2480.240	91.25	0.31	91.56	74.00	17.56	peak
2	2483.500	60.19	0.33	60.52	74.00	-13.48	peak
3	2483.500	50.21	0.33	50.54	54.00	-3.46	AVG
4	2500.640	46.06	0.35	46.41	74.00	-27.59	peak

Note: 1. Result Level = Read Level + Antenna Factor + Cable loss - PRM Factor
 2. If Peak Result comply with AV limit, AV Result is deemed to comply with AV limit

Band edge Test Result

Test Site : 3m Chamber
Test Date : 2013-08-16 **Tested By** : Mike Yang
EUT : RockCandy Wireless Controller for Wii **Model Number** : PL-8560C
Power Supply : DC 3V **Test Mode** : GFSK Hopping on
Condition : Temp:24.5°C,Humi:55% **Antenna** : V

Data : 47

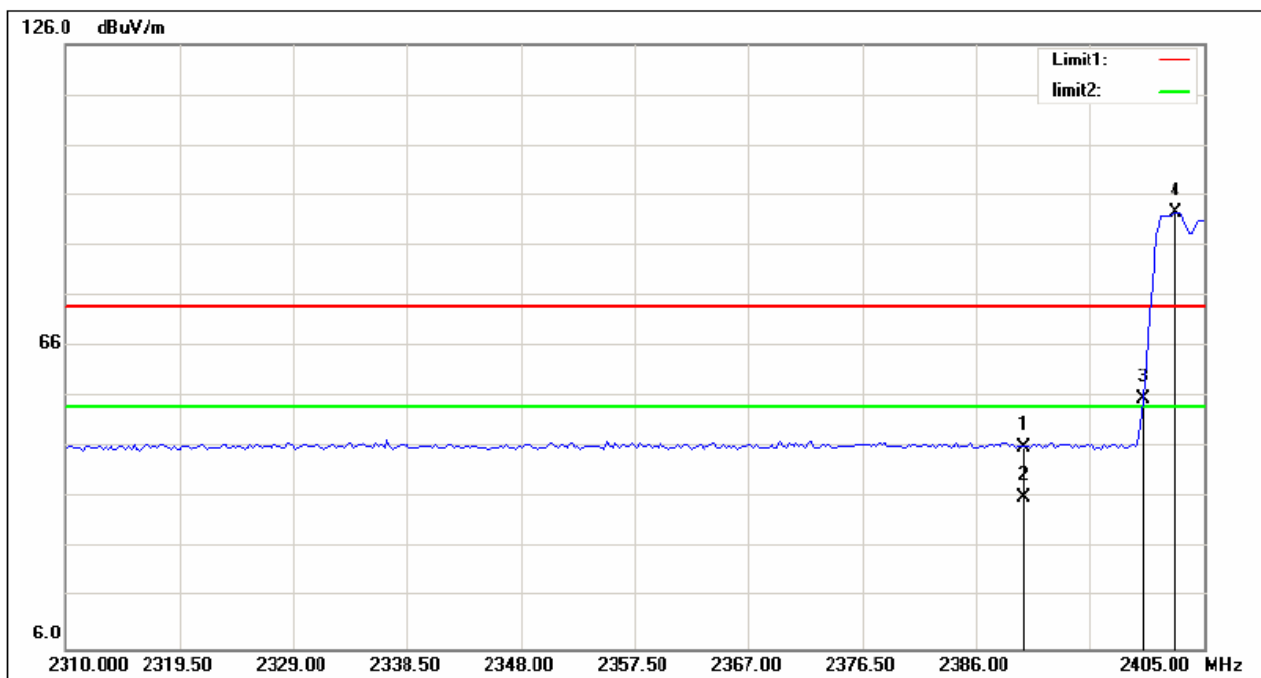

No.	Frequency (MHz)	Reading (dBuV/m)	Correct Factor(dB/m)	Result (dBuV/m)	Limit (dBuV/m)	Margin (dB)	Remark
1	2390.000	45.92	0.17	46.09	74.00	-27.91	peak
2	2390.037	36.01	0.17	36.18	54.00	-17.82	AVG
3	2400.000	55.45	0.18	55.63	74.00	-18.37	peak
4	2402.625	92.40	0.18	92.58	74.00	18.58	peak

Note: 1. Result Level = Read Level + Antenna Factor + Cable loss - PRM Factor
 2. If Peak Result comply with AV limit, AV Result is deemed to comply with AV limit

Band edge Test Result

Test Site : 3m Chamber
Test Date : 2013-08-16 **Tested By** : Mike Yang
EUT : RockCandy Wireless Controller for Wii **Model Number** : PL-8560C
Power Supply : DC 3.7V **Test Mode** : GFSK Hopping on
Condition : Temp:24.5°C,Humi:55% **Antenna** : H

Data : 48

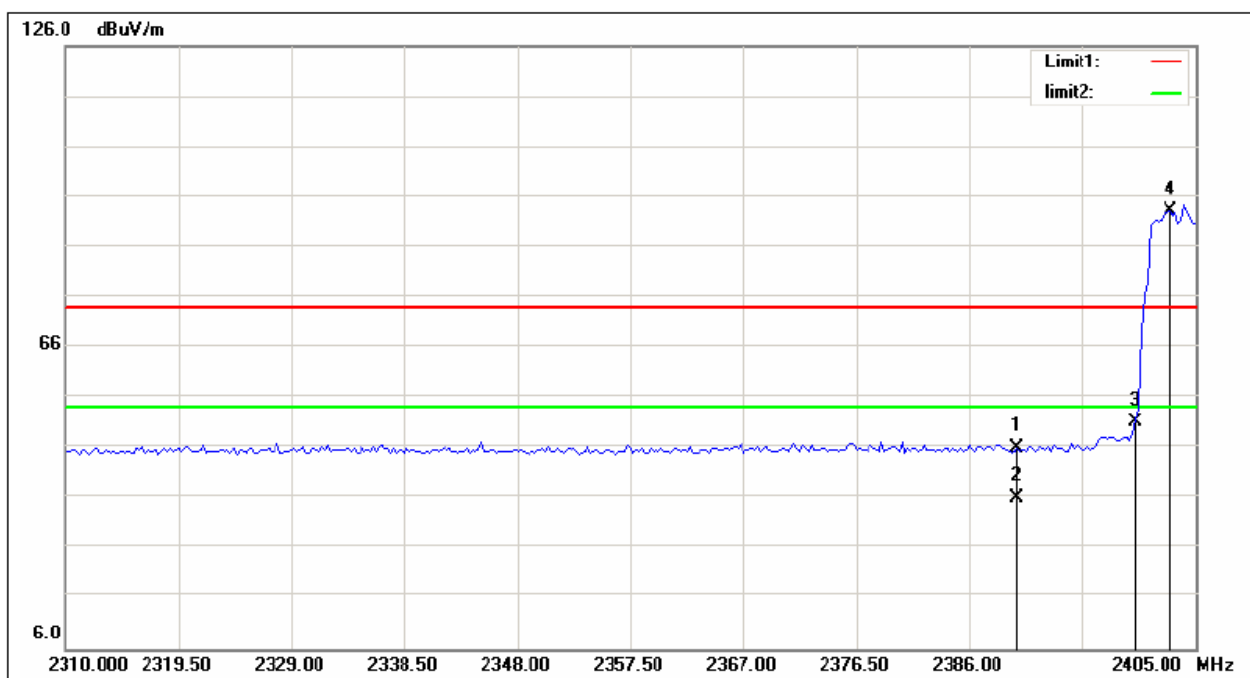

No.	Frequency (MHz)	Reading (dBuV/m)	Correct Factor(dB/m)	Result (dBuV/m)	Limit (dBuV/m)	Margin (dB)	Remark
1	2390.000	45.76	0.17	45.93	74.00	-28.07	peak
2	2390.037	35.95	0.17	36.12	54.00	-17.88	AVG
3	2400.000	50.85	0.18	51.03	74.00	-22.97	peak
4	2402.863	93.07	0.18	93.25	74.00	19.25	peak

Note: 1. Result Level = Read Level + Antenna Factor + Cable loss - PRM Factor
 2. If Peak Result comply with AV limit, AV Result is deemed to comply with AV limit

10.CONDUCTED SPURIOUS EMISSIONS

10.1. Test Equipment

Item	Equipment	Manufacturer	Model No.	Serial No.	Last Cal.	Cal. Interval
1	Spectrum analyzer	Agilent	E4407B	US40240708	2013/07/18	1Y
2	Attenuator	Mini-Circuits	BW-S10W2	101109	2012/12/28	1 Y
3	RF Cable	Micable	C10-01-01-1	100309	2012/12/28	1 Y

10.2. Limit

In any 100kHz bandwidth outside the frequency bands in which the spread spectrum intentional radiator is operating, the radio frequency power that is produced by the intentional radiator shall be at least 20dB below that in the 100kHz bandwidth within the band that contains the highest level of the desired power.

10.3. Test Procedure

The transmitter output was connected to a spectrum analyzer, The resolution bandwidth is set to 100 kHz, The video bandwidth is set to 300 kHz and measure all the emissions detected.

10.4. Test result

PASS (The testing data was attached in the next pages.)

GFSK
2402

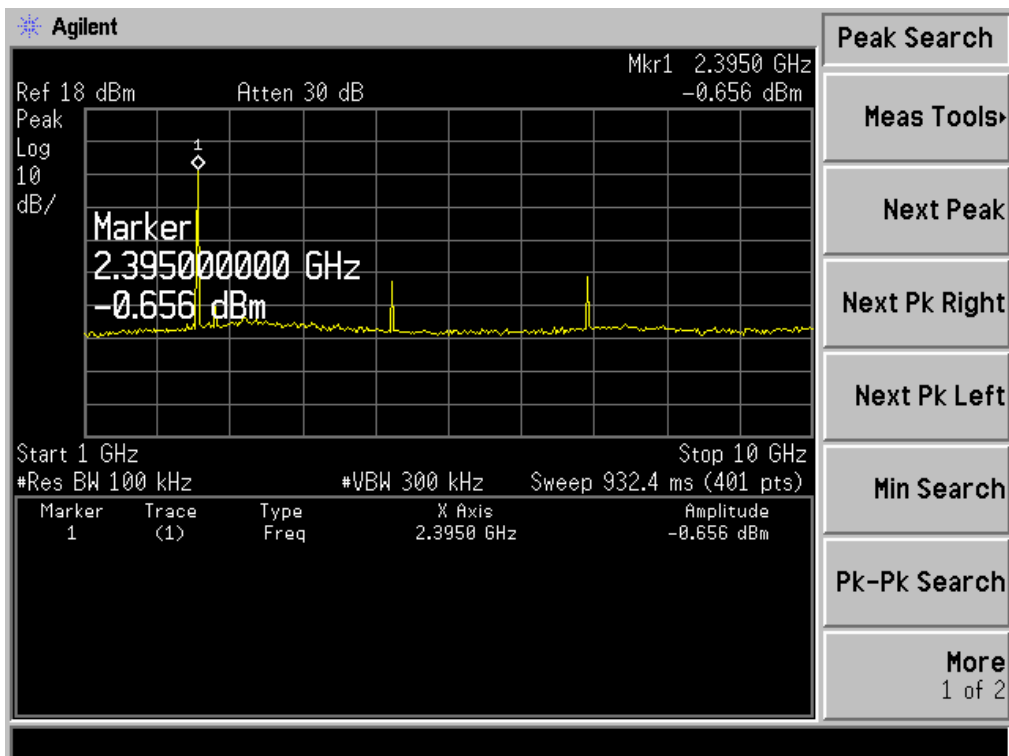
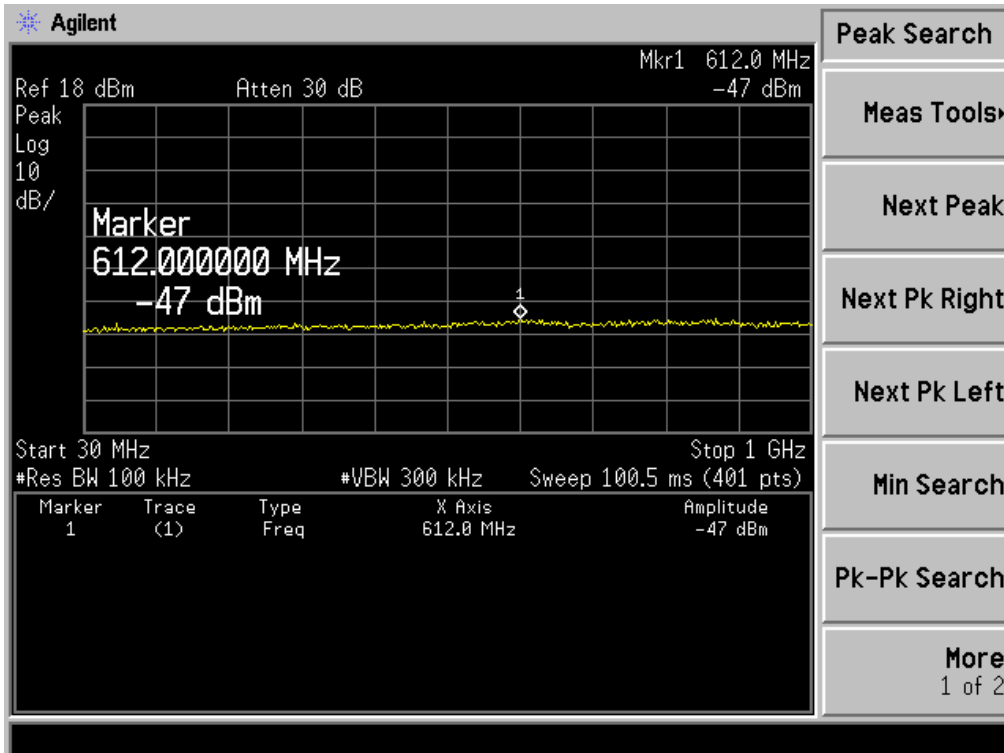

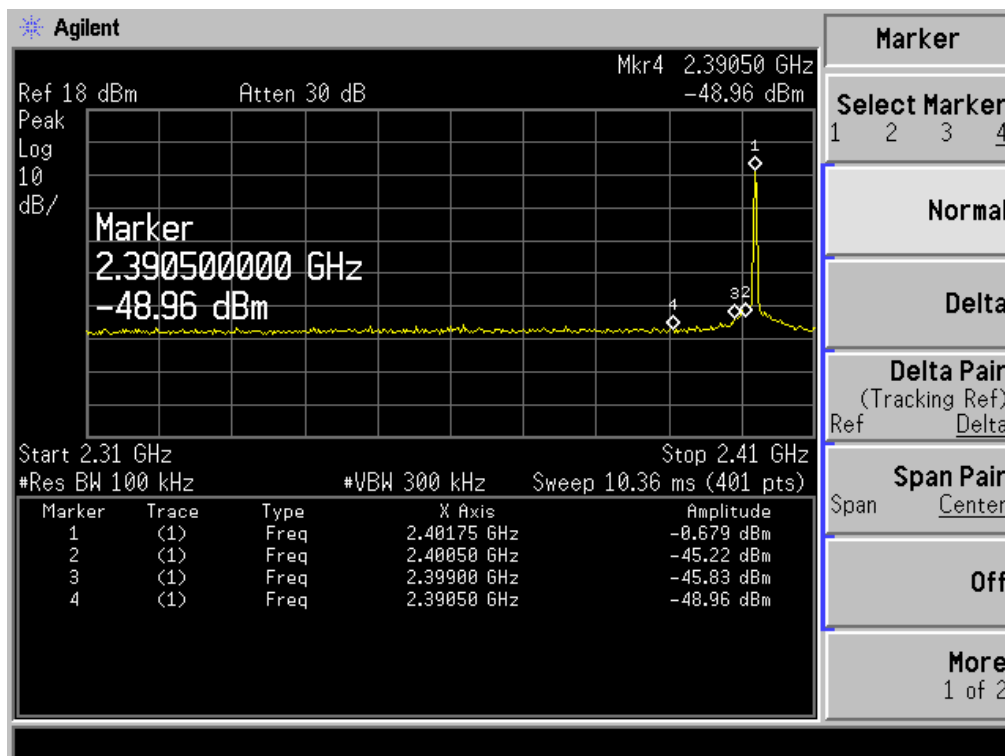
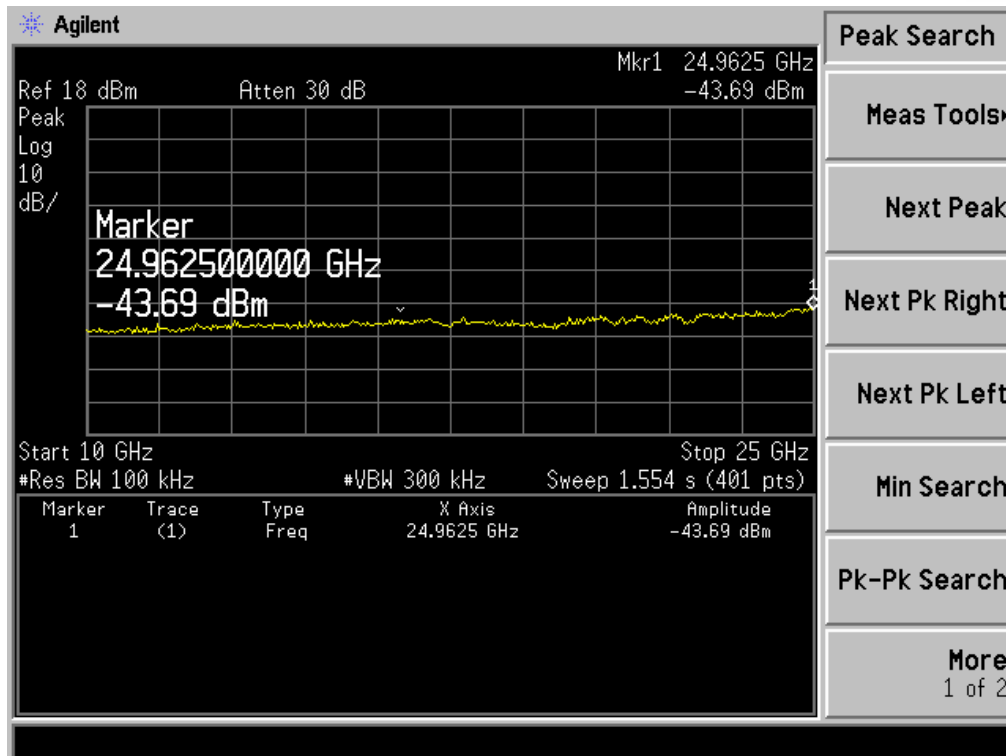

2441

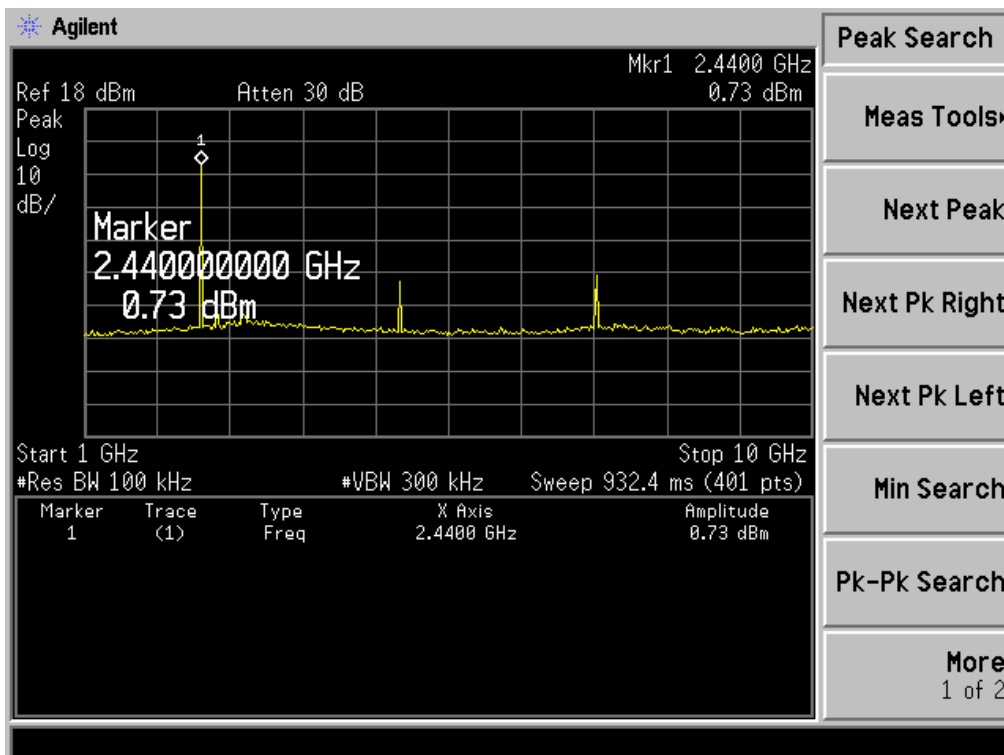
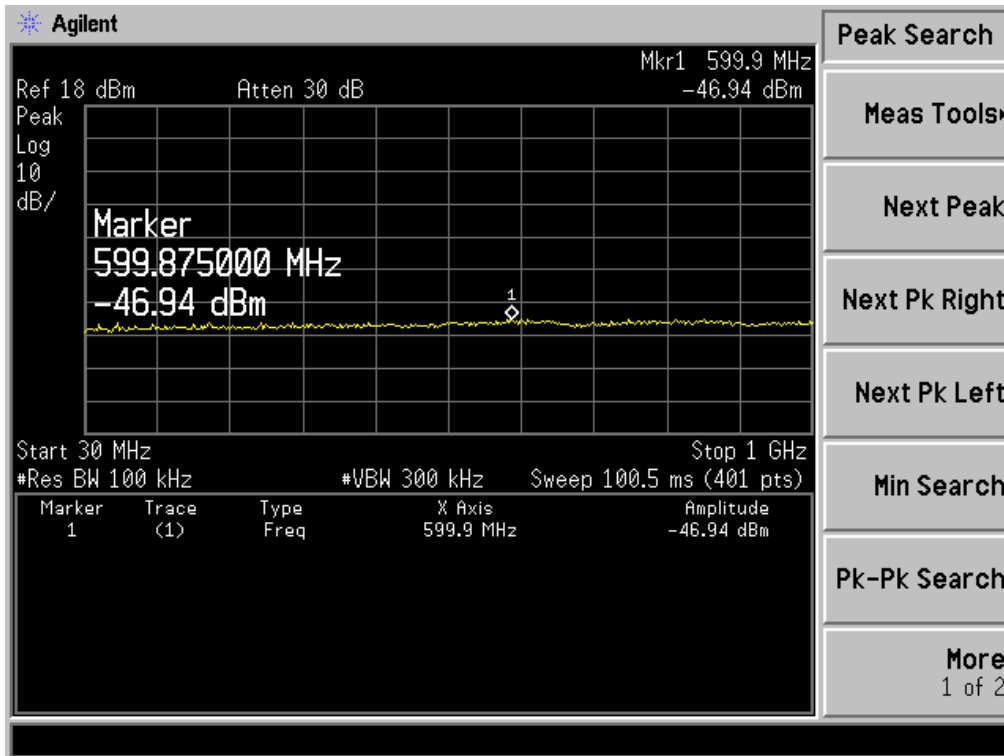

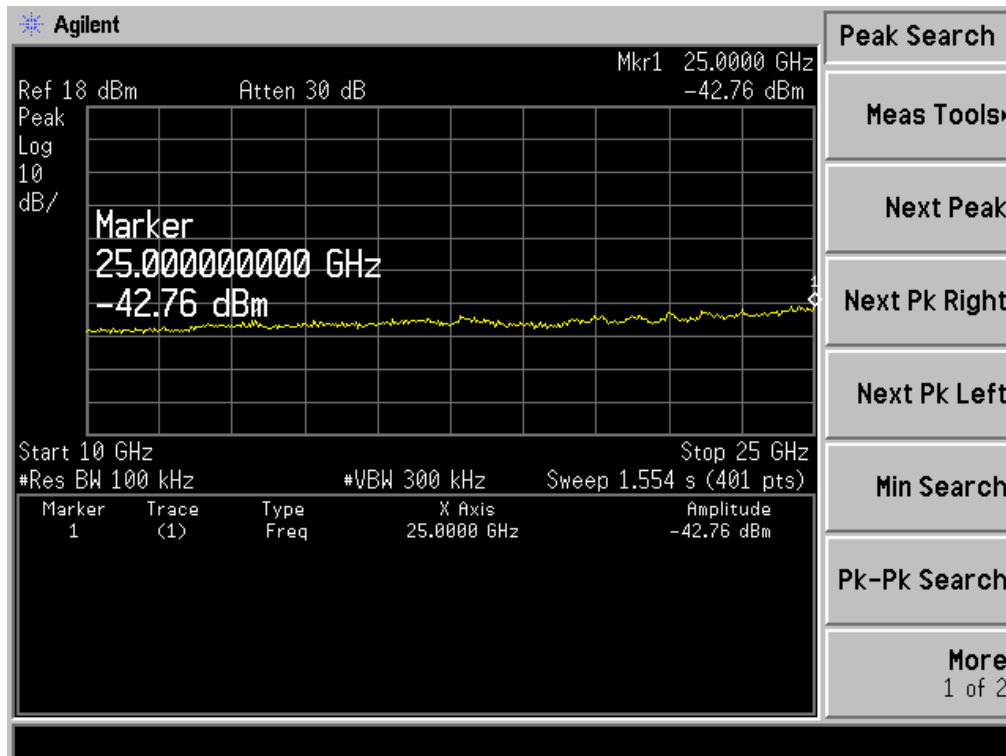

2480

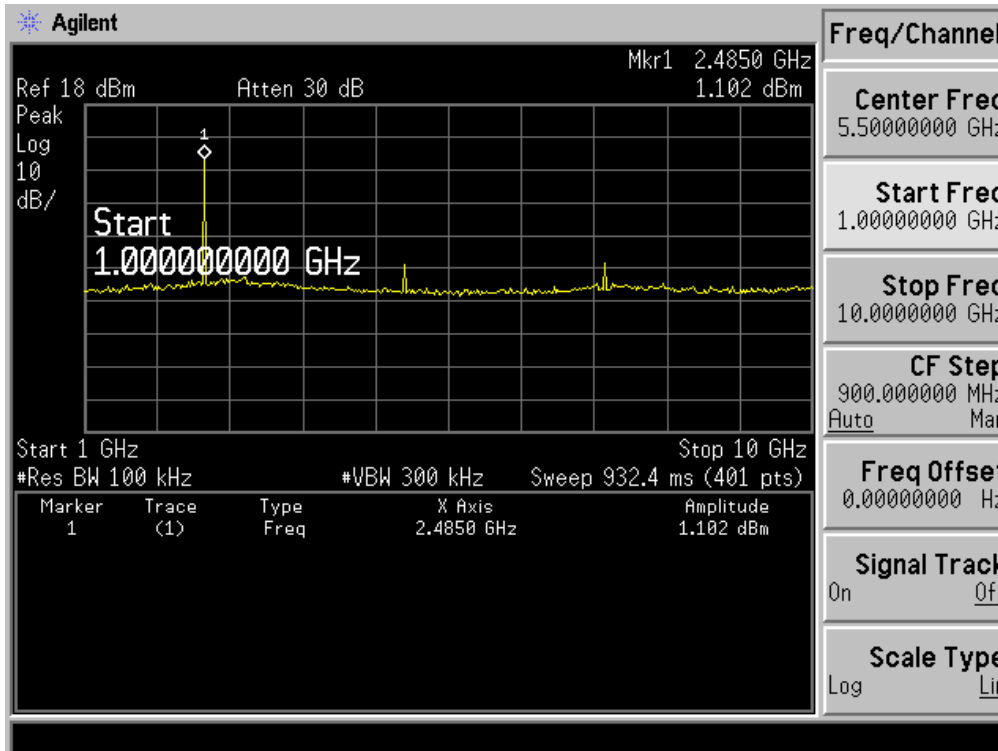

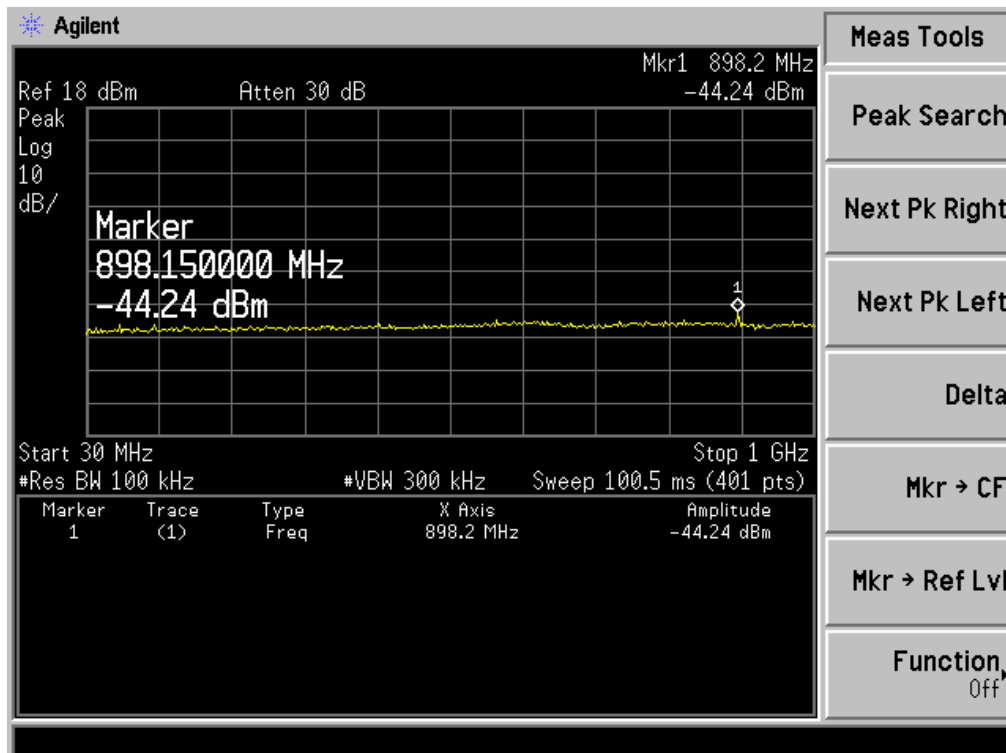
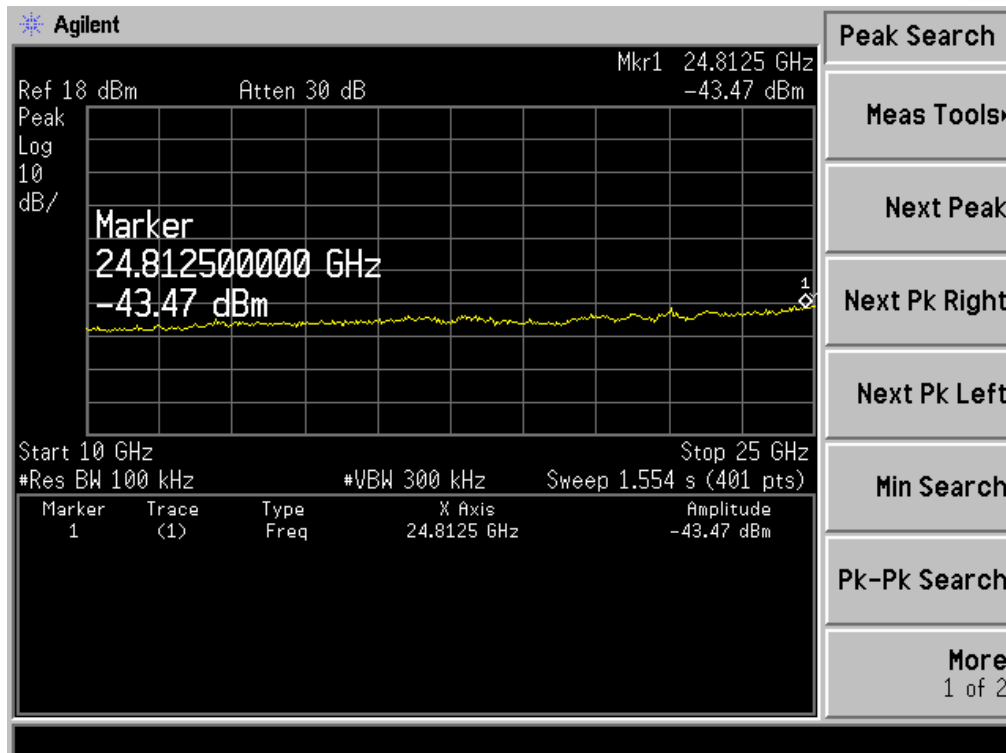

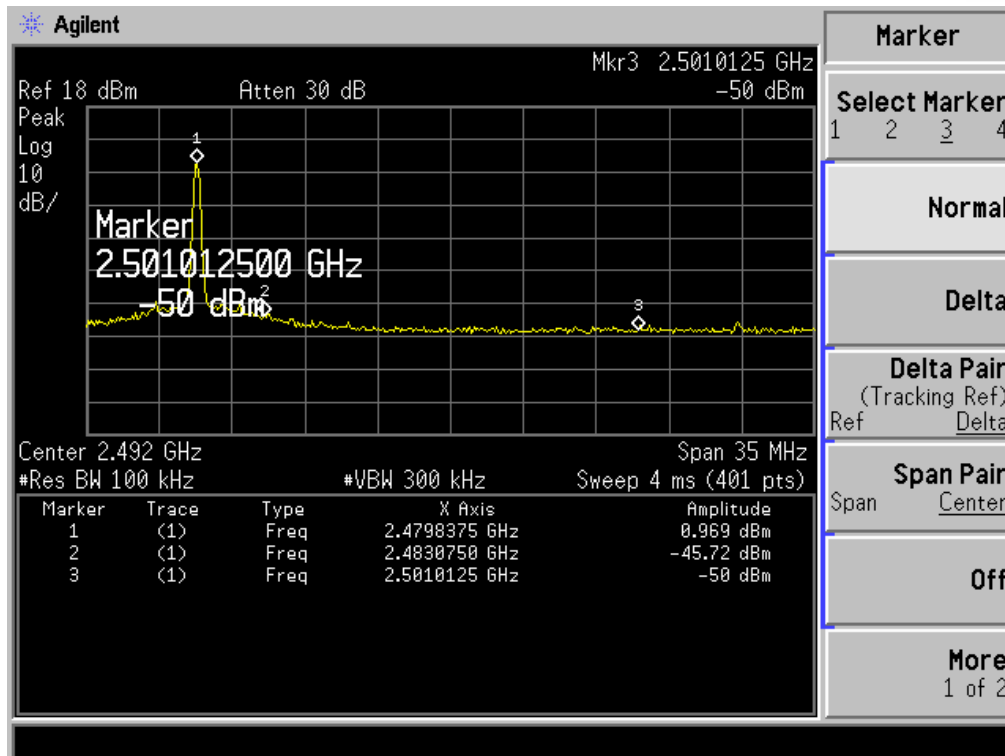

11. Antenna Requirements

11.1 Limit

For intentional device, according to FCC 47 CFR Section 15.203, an intentional radiator shall be designed to ensure that no antenna other than that furnished by the responsible party shall be used with the device. And according to FCC 47 CFR Section 15.247 (b), if transmitting antennas of directional gain greater than 6dBi are used, the power shall be reduced by the amount in dB that the directional gain of the antenna exceeds 6dBi.

11.2 Result

The antennas used for this product are built-in “F” shape PCB antenna and that no antenna other than that furnished by the responsible party shall be used with the device, the maximum peak gain of the transmit antenna is only 0.81dBi.

12.RF Exposure

Applicable Standard

According to 15.247(e)(i) and 1.1310, Systems operating under the provisions of this section shall be operated in a manner that ensure that the public is not exposed to radio frequency energy level in excess of the Commission's guideline.

According to KDB 447498 D01 Mobile Portable RF Exposure V05 Appendix A, SAR can be exempted if the output power is less than the SAR exclusion threshold:

For $f=2450$, the output power is less 10mW at distance of 5mm.

Measurement Result

Peak conducted putput power=2.30dBm

Antenna gain=0.81dBi

SAR exclusion threshold 10Mw(10dBm)>2.92dBm

So the SAR evaluation is not necessary.

13.Test setup photograph

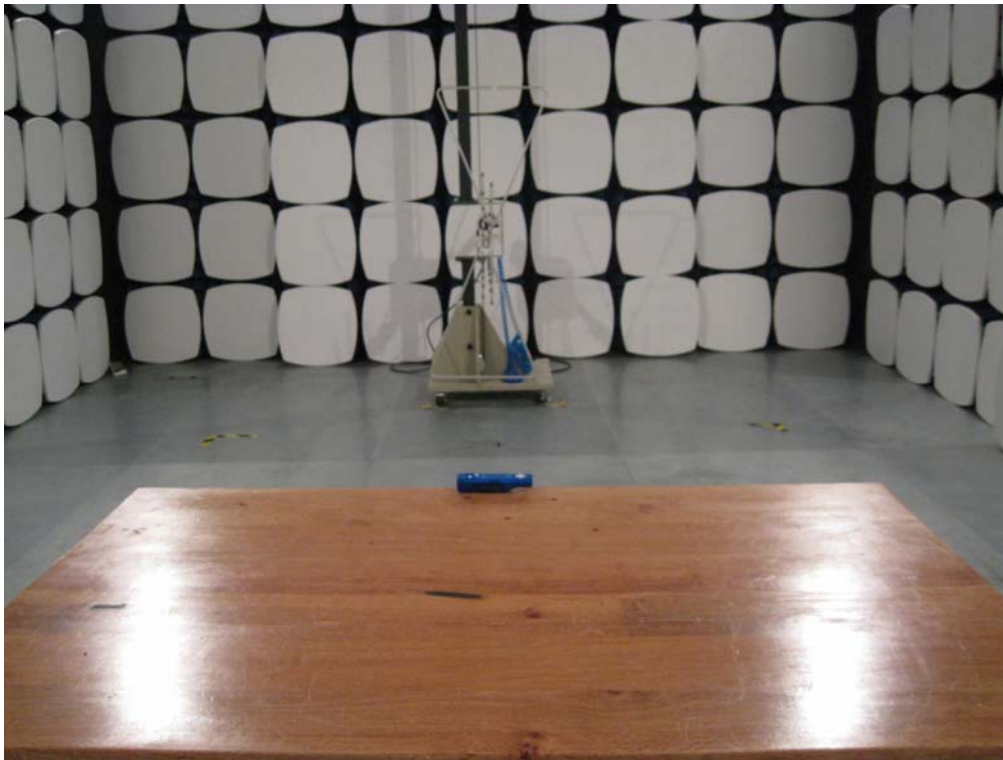

14.Photos of the EUT



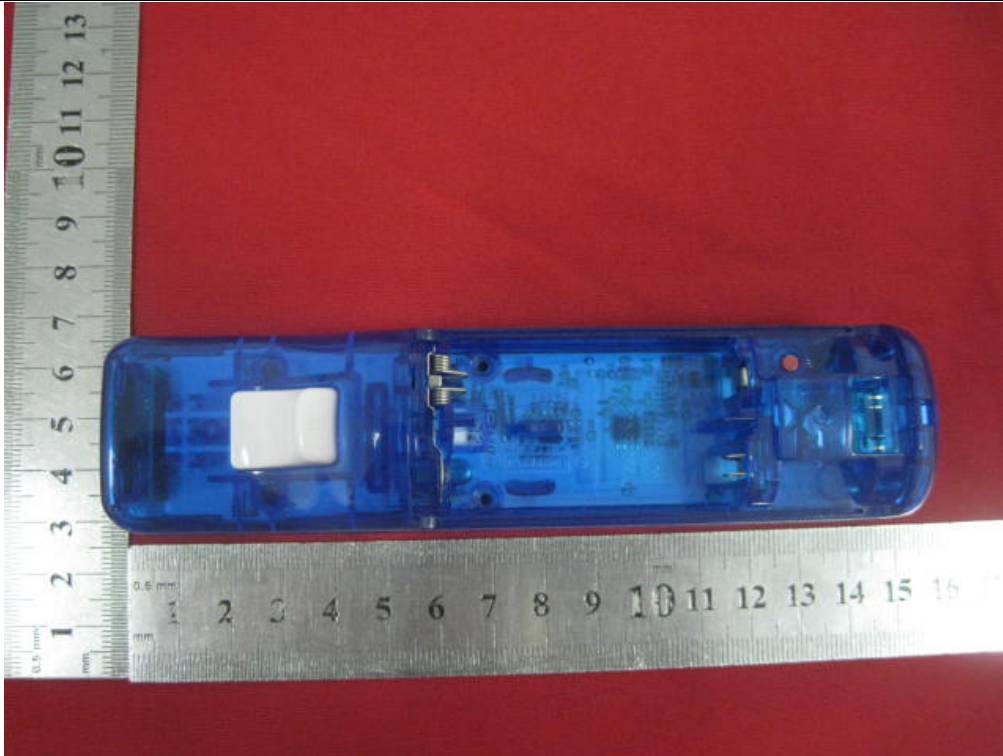

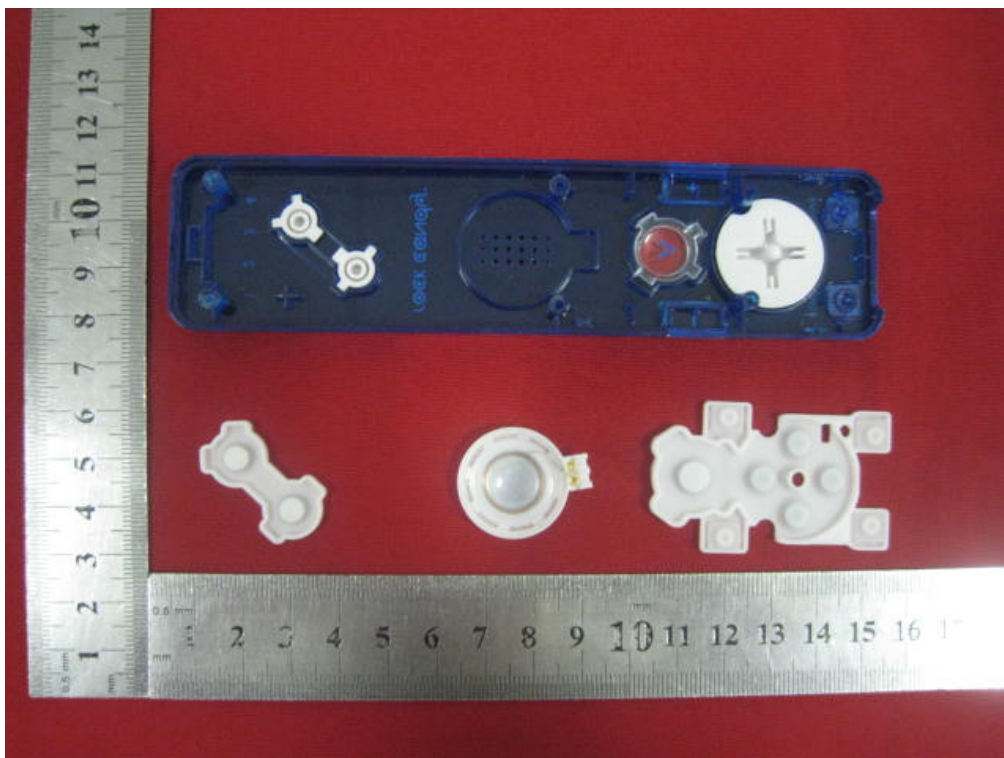
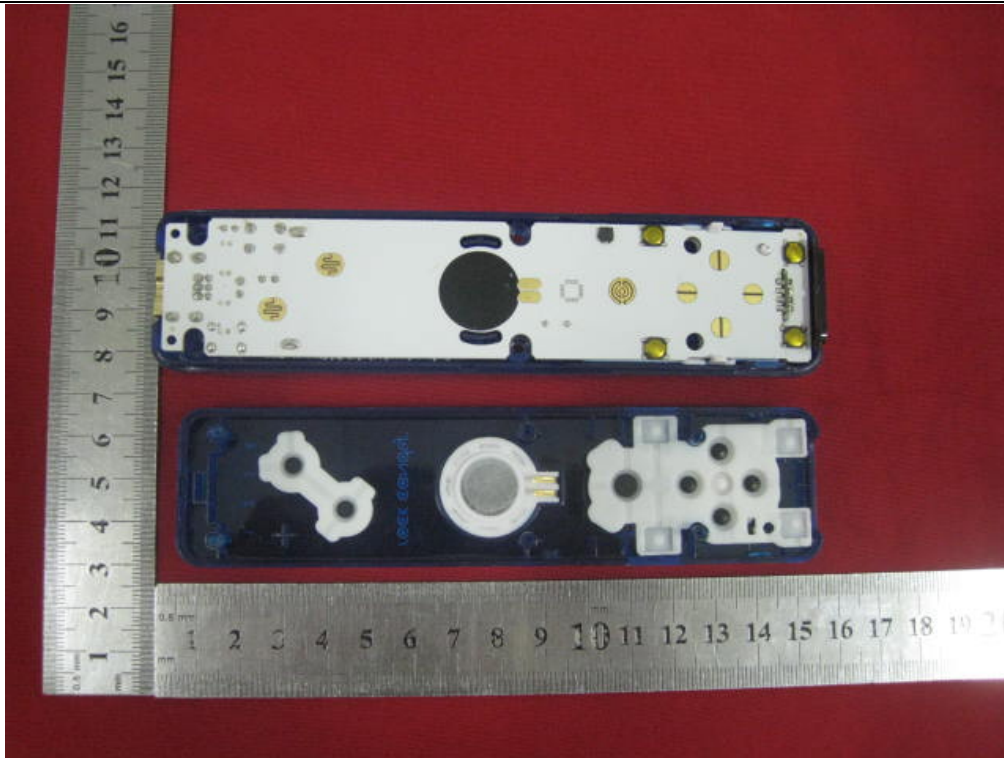

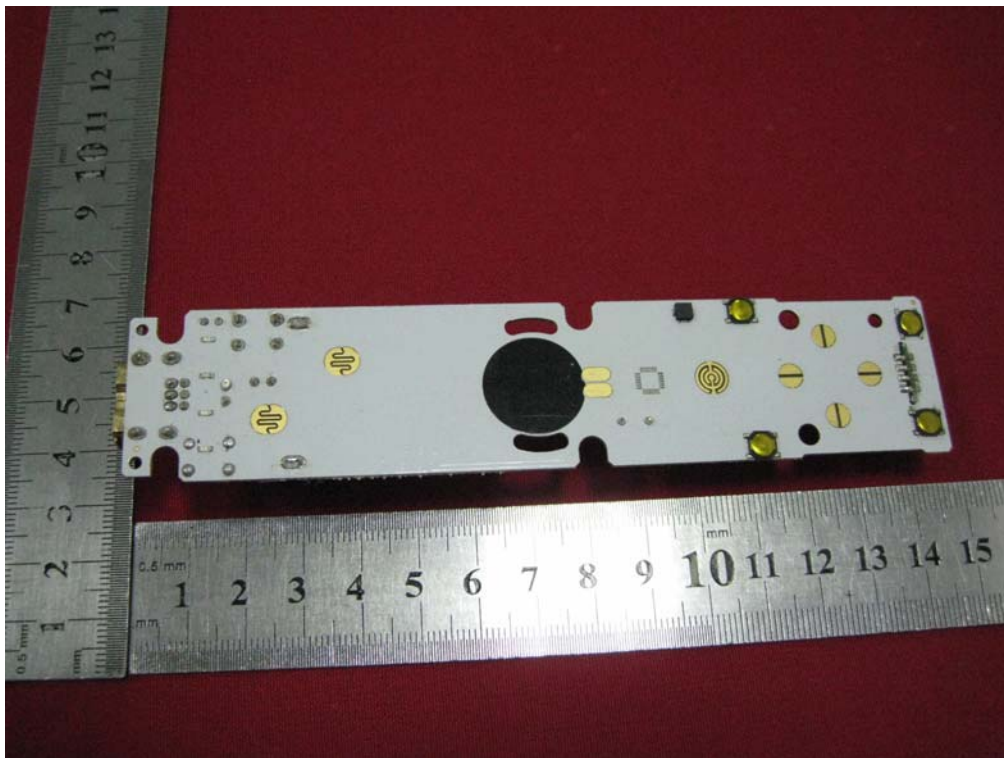
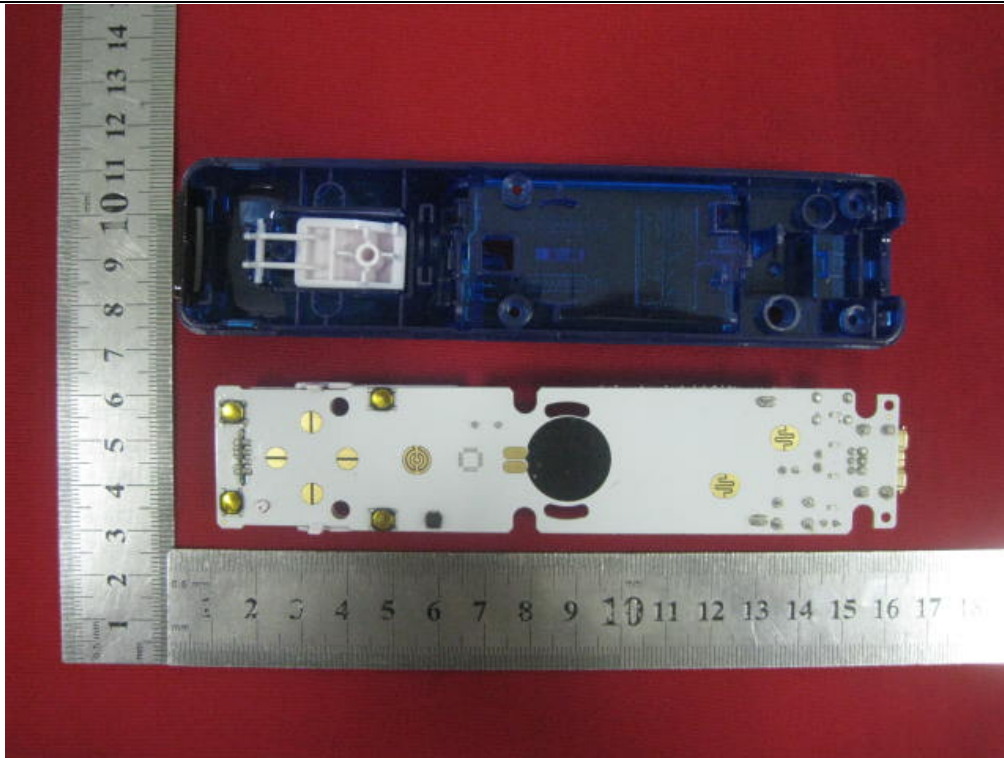

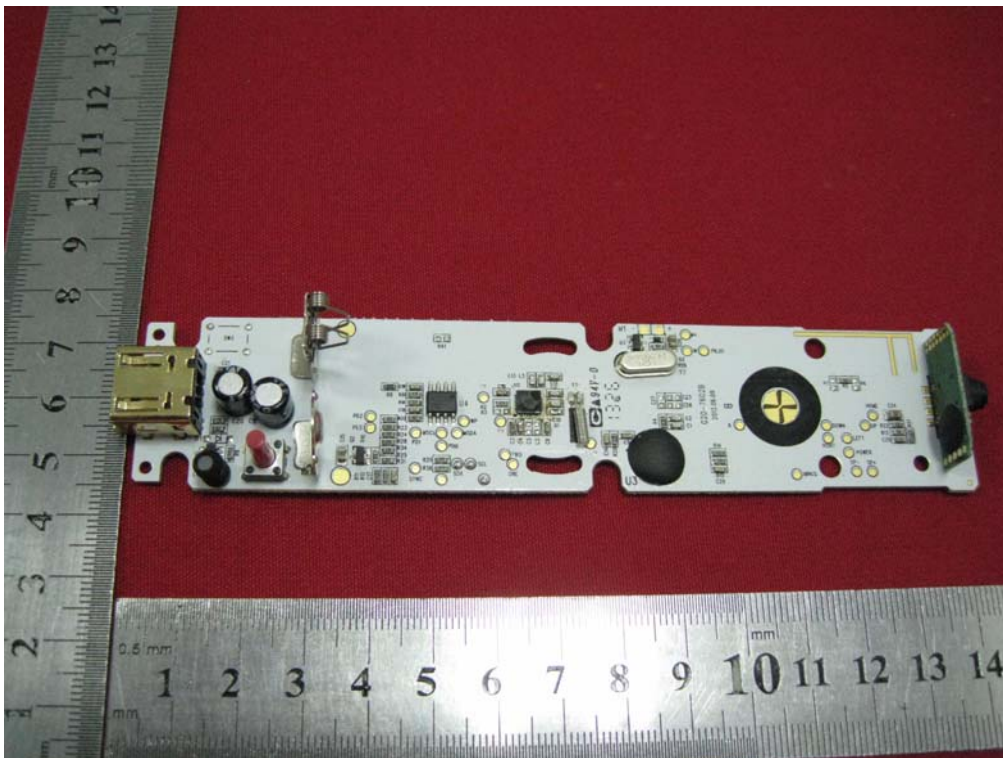
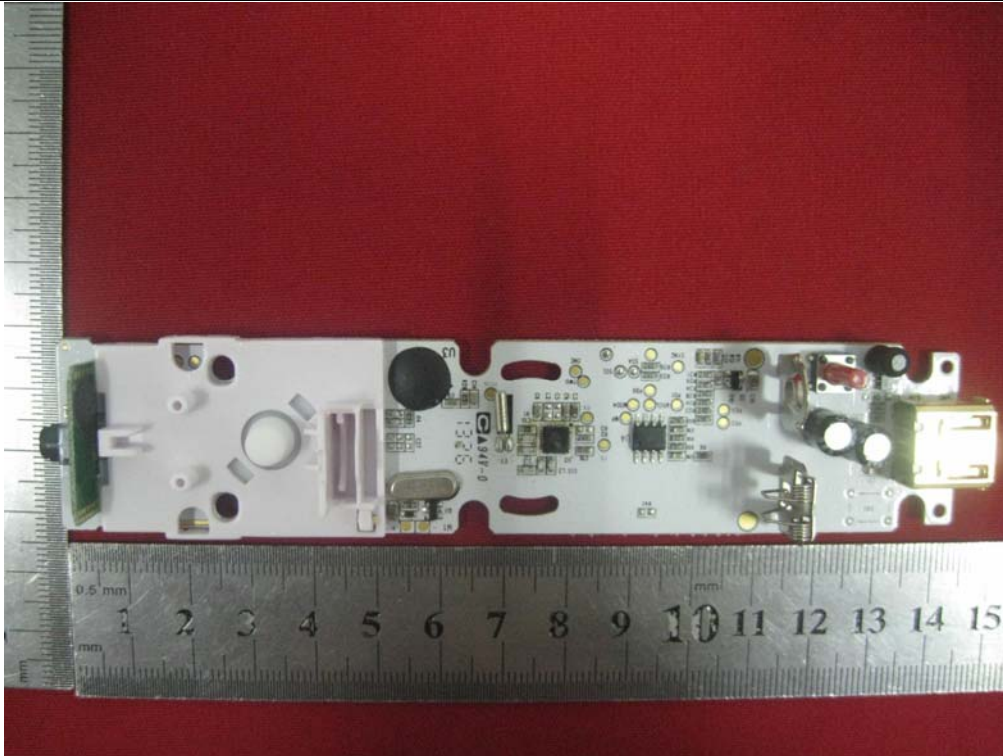

END OF REPORT