

# FCC CERTIFICATION TEST REPORT FOR

FCC ID: X5B-PL6422BT

Report Reference No. .... : 14FAB11015 61

Date of issue ..... : 2014-12-05

Testing Laboratory ..... : ATT Product Service Co., Ltd.

Address ..... : No. 3, ChangLianShan Industrial Park, ChangAn Town,  
DongGuan City, GuangDong, China.

Applicant's name ..... : PERFORMANCE DESIGNED PRODUCTS, LLC

Address ..... : 14144 Ventura Blvd Suite 200 Sherman Oaks CA USA  
91423

Manufacturer ..... : PERFORMANCE DESIGNED PRODUCTS, LLC

Test specification:

Test item description ..... : Afterglow Wireless Controller for PS3 (Controller)

Trade Mark ..... : --

Model/Type reference ..... : PL-6422BT

Ratings ..... : 3.7V dc (Rechargeable Battery)

Responsible Engineer

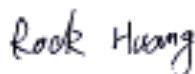

(Rock Huang/ Engineer)

Approved by

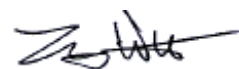

(Tomy Wu /EMC Manager)

## TABLE OF CONTENTS

TEST REPORT DECLARE .....	3
1. Summary of test Standards and results .....	4
2. General test information.....	5
2.1 ACCREDITATIONS.....	5
2.2 Description of EUT.....	5
2.3 Accessories of EUT .....	5
2.4 Assistant equipment used for test.....	5
2.5 Block diagram of EUT configuration for test.....	6
2.6 Test environment conditions .....	6
2.7 Measurement uncertainty .....	6
3. 20dB Bandwidth .....	7
3.1 Test equipment.....	7
3.2 Block diagram of test setup.....	7
3.3 Applicable Standard .....	7
3.4 Test Procedure.....	7
3.5 Test Result.....	8
3.6 Original test data.....	8
4. Radiated emission.....	10
4.1 Test equipment.....	10
4.2 Block diagram of test setup.....	10
4.3 Limit.....	11
4.4 Test Procedure.....	13
4.5 Test result .....	13
5. Antenna Requirements.....	16
5.1 Limit.....	16
5.2 Result.....	16
6. Power Line Conducted Emission.....	16
6.1 Test equipment.....	16
6.2 Block diagram of test setup.....	16
6.3 Power Line Conducted Emission Limits(Class B).....	17
6.4 Test Procedure.....	17
6.5 Test Result.....	18
7. EUT TEST PHOTO.....	20

## TEST REPORT DECLARE

<b>Applicant</b>	:	PERFORMANCE DESIGNED PRODUCTS, LLC
<b>Address</b>	:	14144 Ventura Blvd Suite 200 Sherman Oaks CA USA 91423
<b>Equipment under Test</b>	:	Afterglow Wireless Controller for PS3 (Controller)
<b>Model No</b>	:	PL-6422BT
<b>Trade Mark</b>	:	--
<b>Manufacturer</b>	:	PERFORMANCE DESIGNED PRODUCTS, LLC
<b>Address</b>	:	14144 Ventura Blvd Suite 200 Sherman Oaks CA USA 91423

**Test Standard Used:** FCC Rules and Regulations Part 15 Subpart C: 2010

**Test procedure used:** ANSI C63.10:2009; ANSI C63.4: 2009  
FCC Public Notice DA 00-705

**We Declare:**

The equipment described above is tested by ATT Product Service Co., Ltd. and in the configuration tested the equipment complied with the standards specified above. The test results are contained in this test report and ATT Product Service Co., Ltd. is assumed of full responsibility for the accuracy and completeness of these tests.

**After test and evaluation X/Y/Z axis of the EUT. will record worst case in this report. our opinion is that the equipment provided for test compliance with the requirement of the above FCC standards.**

<b>Report No:</b>	14FAB11015 61		
<b>Date of Test:</b>	2014-11-18---2014-12-04	<b>Date of Report:</b>	2014-12-05

Note: This report applies to above tested sample only. This report shall not be reproduced in parts without written approval of ATT Product Service Co., Ltd.

## 1. Summary of test Standards and results

The EUT have been tested according to the applicable standards as referenced below.

Description of Test Item	Standard	Results
20dB Bandwidth	&15. 215(c) ANSI C63.10 :2009	PASS
Radiated Emission	15.209,&15.205,&15.249 ANSI C63.10 :2009	PASS
Conducted Emissions	&15.207(a) ANSI C63.10 :2009	PASS
Antenna requirement	&15.203	PASS
Outside of Band Emission	&15.249(d)	PASS

## 2.General test information

### 2.1 ACCREDITATIONS

The measuring facility of laboratories has been authorized or registered by the following approval agencies.

**USA**                      **FCC**                      **Registration Number :923232**  
**Canada**                **INDUSTRY CANADA**                **Registration Number 11033A**

### 2.2Description of EUT

EUT* Name	:	Afterglow Wireless Controller for PS3 (Controller)
Model Number	:	PL-6422BT
Trade Mark	:	--
EUT function description	:	Please reference user manual of this device
Power supply	:	3.7V d.c (Rechargeable Battery)
Operation frequency	:	2402MHz -2480MHz
Modulation	:	GFSK
Data rate	:	1Mbps
Antenna Type	:	PCB layout antenna, maximum PK gain:0dBi
Date of Receipt	:	2014-11-17
Sample Type	:	Solo production

### 2.3Accessories of EUT

Description of Accessories	Manufacturer	Model number or Type	Other
USB Cable	Customer Supply	2.5m With Shielding	/

### 2.4Assistant equipment used for test

Description of Assistant equipment	Manufacturer	Model number or Type	FCC Status	Other
PS3 Game Machine	Sony	CECH-4006B	FCC VOC	03-27445859-56363 27-CECH-4006B
TV	OLYMP	14"TV	FCC VOC	--

### 2.5 Block diagram of EUT configuration for test

Tested mode, channel, information		
Test Mode	Channel	Frequency (MHz)
Tx Mode	Lowest	2402
	Middle	2441
	Highest	2480

### 2.6 Test environment conditions

During the measurement the environmental conditions were within the listed ranges:

Temperature range:	21-25°C
Humidity range:	40-75%
Pressure range:	86-106kPa

### 2.7 Measurement uncertainty

Test Item	Uncertainty
Uncertainty for Conduction emission test	2.44dB
Uncertainty for Radiation Emission test (150KHz-30MHz)	3.21dB
Uncertainty for Radiation Emission test (30MHz-200MHz)	3.42 dB (Polarize: V)
	3.52 dB (Polarize: H)
Uncertainty for Radiation Emission test (200MHz-1GHz)	3.52 dB (Polarize: V)
	3.54 dB (Polarize: H)
Uncertainty for Radiation Emission test (1GHz to 25GHz)	4.20 dB (Polarize: V)
	4.20 dB (Polarize: H)
Uncertainty for radio frequency	1x10-9
Uncertainty for conducted RF Power	0.65dB

Note: This uncertainty represents an expanded uncertainty expressed at approximately the 95% confidence level using a coverage factor of k=2.

### 3. 20dB Bandwidth

#### 3.1 Test equipment

Item	Equipment	Manufacturer	Model No.	Serial No.	Cal Due.	Cal. Interval
1	EMI Test Receiver	R&S	ESCI	101307	2014/12/26	1Y
2	Attenuator	Mini-Circuits	BW-S10W2	101109	2014/12/27	1Y
3	RF Cable	Micable	C10-01-01-1	100309	2014/12/27	1Y

#### 3.2 Block diagram of test setup

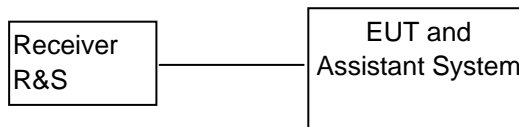

#### 3.3 Applicable Standard

Intentional radiators operating under the alternative provisions to the general emission limits, as contained in §§ 15.217 through 15.257 and in Subpart E of this part, must be designed to ensure that the 20dB bandwidth of the emission, or whatever bandwidth may otherwise be specified in the specific rule section under which the equipment operates, is contained within the frequency band designated in the rule section under which the equipment is operated.

#### 3.4 Test Procedure

1. Check the calibration of the measuring instrument using either an internal calibrator or a known signal from an external generator.
2. Position the EUT on the test table without connection to measurement instrument. Turn on the EUT. Then set it to any one convenient frequency within its operating range. Set a reference level on the measuring instrument equal to the highest peak value.
3. Measure the frequency difference of two frequencies that were attenuated 20dB from the reference level. Record the frequency difference as the emission bandwidth.
4. Repeat above procedures until all frequencies measured were complete..

### 3.5 Test Result

EUT: Afterglow Wireless Controller for PS3 (Controller)			M/N: PL-6422BT		
Mode	Freq (MHz)	Result (MHz)	Limit (MHz)	Margin (MHz)	Conclusion
Tx	2402	1.116	/	/	PASS
	2441	1.136	/	/	PASS
	2480	1.148	/	/	PASS
Test Date : 2014-11-28			Test Engineer : Rock Huang		

### 3.6 Original test data

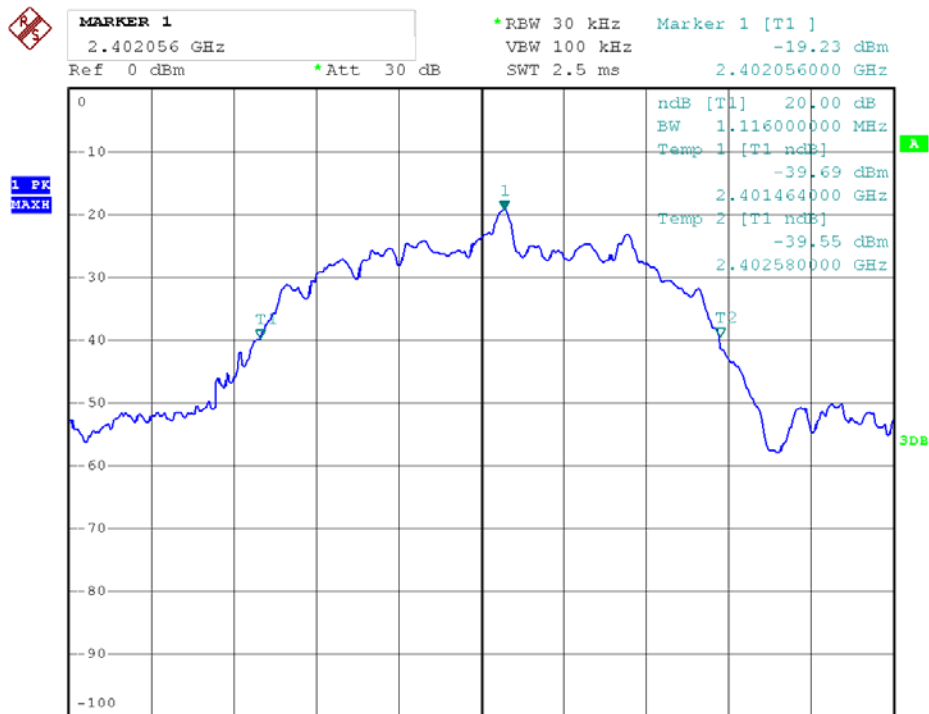



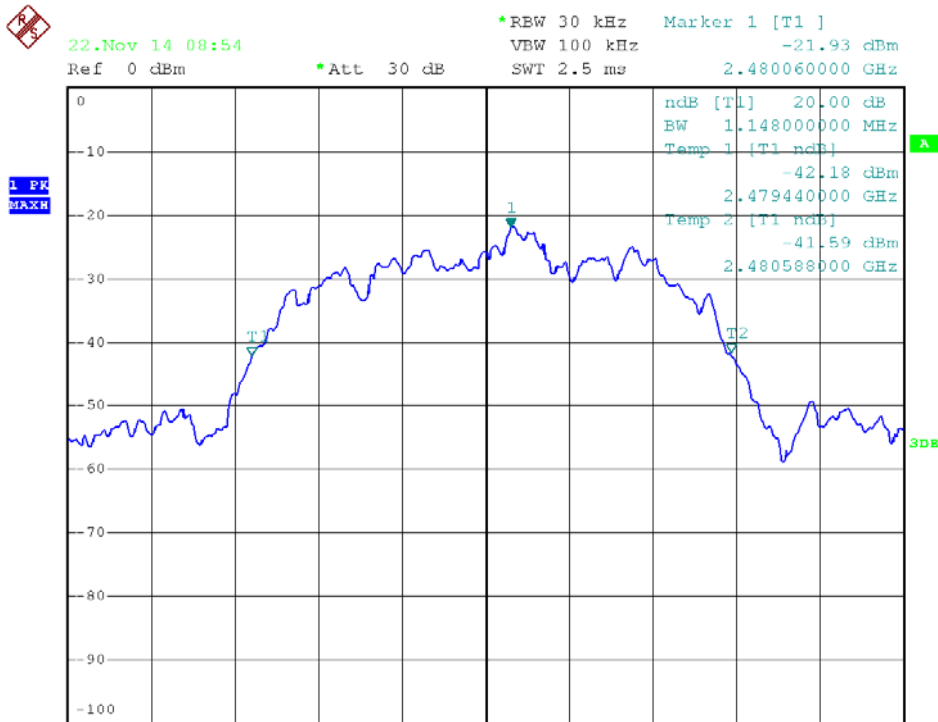

## 4. Radiated emission

### 4.1 Test equipment

Item	Equipment	Manufacturer	Model No.	Serial No.	Cal Due.	Cal. Interval
1	EMI Test Receiver	R&S	ESCI	101307	2014/12/26	1Y
2	Spectrum analyzer	Agilent	E4407B	US40240708	2015/07/11	1Y
3	Loop antenna	Chase	HLA6120	20129	2014/12/27	1Y
4	Trilog Broadband Antenna	Schwarzbeck	VULB9163	9163-462	2014/12/27	1Y
5	Double Ridged Horn Antenna	R&S	HF907	100276	2014/12/27	1Y
6	Pre-Amplifier	R&S	SCU-01	10049	2014/12/27	1Y
7	Pre-amplifier	A.H.	PAM0-0118	360	2014/12/27	1Y
8	RF Cable	R&S	R01	10403	2014/12/27	1Y
9	RF Cable	R&S	R02	10512	2014/12/27	1Y
10	Horn Antenna	EMCO	3116	9608-4877	2014/12/27	1Y

### 4.2 Block diagram of test setup

In 3m Anechoic Chamber Test Setup Diagram for below 1GHz

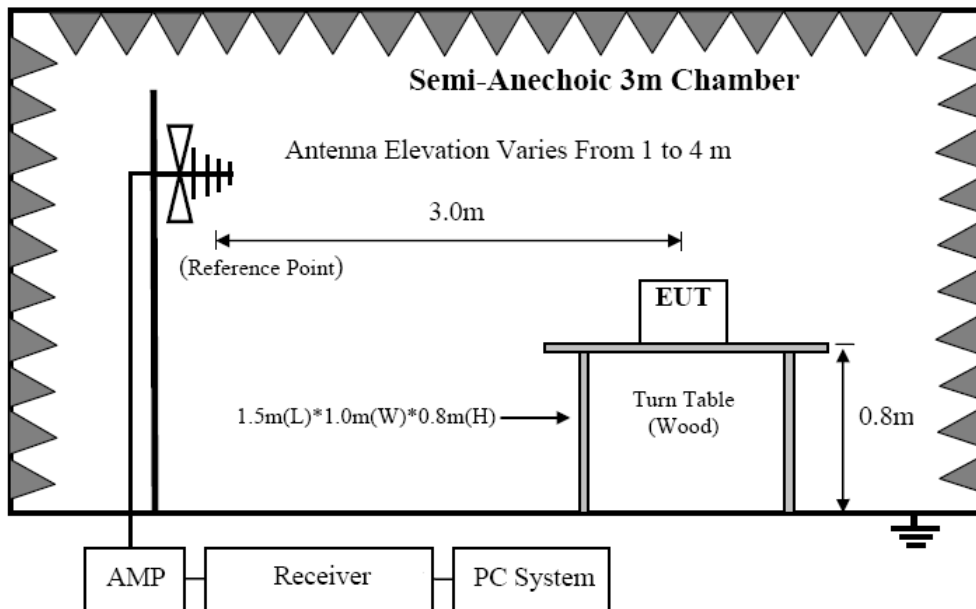

In 3m Anechoic Chamber Test Setup Diagram for frequency above 1GHz

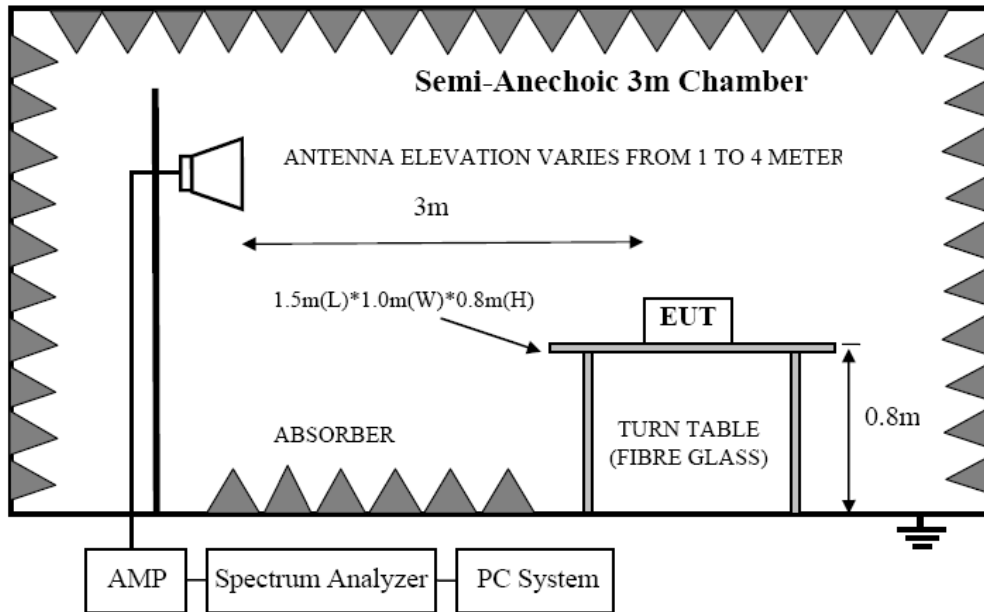

Note: For harmonic emissions test a appropriate high pass filter was inserted in the input port of AMP.

### 4.3 Limit

#### 4.3.1 FCC 15.205 Restricted frequency band

MHz	MHz	MHz	GHz
0.090 - 0.110	16.42 - 16.423	399.9 - 410	4.5 - 5.15
<sup>1</sup> 0.495 - 0.505	16.69475 - 16.69525	608 - 614	5.35 - 5.46
2.1735 - 2.1905	16.80425 - 16.80475	960 - 1240	7.25 - 7.75
4.125 - 4.128	25.5 - 25.67	1300 - 1427	8.025 - 8.5
4.17725 - 4.17775	37.5 - 38.25	1435 - 1626.5	9.0 - 9.2
4.20725 - 4.20775	73 - 74.6	1645.5 - 1646.5	9.3 - 9.5
6.215 - 6.218	74.8 - 75.2	1660 - 1710	10.6 - 12.7
6.26775 - 6.26825	108 - 121.94	1718.8 - 1722.2	13.25 - 13.4
6.31175 - 6.31225	123 - 138	2200 - 2300	14.47 - 14.5
8.291 - 8.294	149.9 - 150.05	2310 - 2390	15.35 - 16.2
8.362 - 8.366	156.52475 - 156.52525	2483.5 - 2500	17.7 - 21.4
8.37625 - 8.38675	156.7 - 156.9	2690 - 2900	22.01 - 23.12
8.41425 - 8.41475	162.0125 - 167.17	3260 - 3267	23.6 - 24.0
12.29 - 12.293	167.72 - 173.2	3332 - 3339	31.2 - 31.8
12.51975 - 12.52025	240 - 285	3345.8 - 3358	36.43 - 36.5
12.57675 - 12.57725	322 - 335.4	3600 - 4400	( <sup>2</sup> )

4.3.2 FCC 15.209 Limit

FREQUENCY MHz	DISTANCE Meters	FIELD STRENGTHS LIMIT	
		$\mu\text{V}/\text{m}$	$\text{dB}(\mu\text{V})/\text{m}$
30 ~ 88	3	100	40.0
88 ~ 216	3	150	43.5
216 ~ 960	3	200	46.0
960 ~ 1000	3	500	54.0
Above 1000	3	74.0 $\text{dB}(\mu\text{V})/\text{m}$ (Peak) 54.0 $\text{dB}(\mu\text{V})/\text{m}$ (Average)	

4.3.2 FCC 15.249 Limit

Fundamental frequency	Field strength of fundamental (millivolts/meter)	Field strength of harmonics (microvolts/meter)
902–928 MHz	50	500
2400–2483.5 MHz	50	500
5725–5875 MHz	50	500
24.0–24.25 GHz	250	2500

4.3.3 Limit for this EUT

The radiated emission tests were performed in the 3 meters test site, using the setup accordance with the ANSI C63.4:2009. The specification used was the FCC 15.209, and FCC 15.249 limits.

#### 4.4 Test Procedure

- (1) EUT was placed on a non-metallic table, 80 cm above the ground plane inside a semi-anechoic chamber.
- (2) Setup EUT and assistant system according clause 2.4 and 8.2
- (3) Test antenna was located 3m from the EUT on an adjustable mast. Below pre-scan procedure was first performed in order to find prominent radiated emissions.
  - (a) Change work frequency or channel of device if practicable.
  - (b) Change modulation type of device if practicable.
  - (c) Change power supply range from 85% to 115% of the rated supply voltage
  - (d) Rotated EUT though three orthogonal axes to determine the attitude of EUT arrangement produces highest emissions
- (4) Spectrum frequency from 9MHz to 25GHz (tenth harmonic of fundamental frequency) was investigated, and no any obvious emission were detected from 9KHz to 30MHz and 18GHz to 25GHz, so below final test was performed with frequency range from 30MHz to 18GHz.
- (5) For final emissions measurements at each frequency of interest, the EUT were rotated and the antenna height was varied between 1m and 4m in order to maximize the emission. Measurements in both horizontal and vertical polarities were made and the data was recorded. In order to find the maximum emission, the relative positions of equipments and all of the interface cables were changed according to ANSI C63.10 2009 on Radiated Emission test.
- (6) For emissions from 30MHz to 1GHz, Quasi-Peak values were measured with EMI Receiver and the bandwidth of Receiver is 120 KHz.
- (7) For emissions above 1GHz, both Peak and Average level were measured with Spectrum Analyzer, and the RBW is set at 1MHz, VBW is set at 3MHz for Peak measure, Detector is at PK; RBW is set at 1MHz, VBW is set at 10Hz for Average measure, Detector is at PK..

#### 4.5 Test result

##### **PASS. (See below detailed test result)**

According to the recorded data in following table, the EUT complied with the FCC Title 47, Part 15, Subpart C and section 15.205, 15.209 and 15.249, Vertical and Horizontal mode all have been tested, Horizontal mode is the worse case, with the worst margin reading of:

## Radiated Emission Test Result

<b>Test Site</b>	: 3m Chamber		
<b>Test Date</b>	: 2014-12-1	<b>Tested By</b>	: Rock Huang
<b>EUT</b>	: Afterglow Wireless Controller for PS3 (Controller)	<b>Model Number</b>	: PL-6422BT
<b>Power Supply</b>	: 3.7Vd.c	<b>Test Mode</b>	: Tx mode
<b>Condition</b>	: Temp:24.5°C,Humi:55%	<b>Antenna/Distan</b>	: 3m

Frequency (MHz)	Receiver		Rx Antenna		Cable loss (dB)	Amplifier Gain (dB)	Result Level (dBµV/m)	FCC 15.249	
	Reading (dBµV)	Detector (PK/QP/A V)	Polar (H/V)	Factor (dB)				Limit (dBµV/m)	Margin (dB)
Low Channel (2402)									
2402.00	62.22	PK	H	28.00	3.65	0.00	93.87	114.00	-20.13
2402.00	54.58	AV	H	28.00	3.65	0.00	86.23	94.00	-7.77
2402.00	60.26	PK	V	28.00	3.65	0.00	91.91	114.00	-22.09
2402.00	55.01	AV	V	28.00	3.65	0.00	86.66	94.00	-7.34
2390.00	9.72	PK	H	28.40	3.57	0.00	41.69	74.00	-32.31
2390.00	4.50	AV	H	28.40	3.57	0.00	36.47	54.00	-17.53
2390.00	10.56	PK	V	28.40	3.57	0.00	42.53	74.00	-31.47
2390.00	4.35	AV	V	28.40	3.57	0.00	36.32	54.00	-17.68
2400.00	10.74	PK	H	28.40	3.57	0.00	42.71	74.00	-31.29
2400.00	2.08	AV	H	28.40	3.57	0.00	34.05	54.00	-19.95
2400.00	7.99	PK	V	28.40	3.57	0.00	39.96	74.00	-34.04
2400.00	-0.21	AV	V	28.40	3.57	0.00	31.76	54.00	-22.24
4804.00	45.18	PK	H	32.30	5.91	31.78	51.61	74.00	-22.39
4804.00	38.36	AV	H	32.30	5.91	31.78	44.79	54.00	-9.21
4804.00	43.39	PK	V	32.30	5.91	31.78	49.82	74.00	-24.18
4804.00	36.31	AV	V	32.30	5.91	31.78	42.74	54.00	-11.26
7206.00	35.53	PK	H	36.30	6.34	30.97	47.20	74.00	-26.80
7206.00	25.63	AV	H	36.30	6.34	30.97	37.30	54.00	-16.70
7206.00	33.43	PK	V	36.30	6.34	30.97	45.10	74.00	-28.90
7206.00	25.75	AV	V	36.30	6.34	30.97	37.42	54.00	-16.58
9608.00	32.95	PK	H	37.90	8.01	30.86	48.00	74.00	-26.00
9608.00	24.62	AV	H	37.90	8.01	30.86	39.67	54.00	-14.33
9608.00	35.42	PK	V	37.90	8.01	30.86	50.47	74.00	-23.53
9608.00	27.53	AV	V	37.90	8.01	30.86	42.58	54.00	-11.42
96.80	47.12	QP	H	12.20	2.59	27.10	34.81	43.50	-8.69
96.80	39.75	QP	V	12.20	2.59	27.10	27.44	43.50	-16.06
Middle Channel (2441)									
2441.00	57.36	PK	H	28.30	3.69	0.00	89.35	114.00	-24.65
2441.00	51.83	AV	H	28.30	3.69	0.00	83.82	94.00	-10.18
2441.00	57.25	PK	V	28.30	3.69	0.00	89.24	114.00	-24.76
2441.00	48.60	AV	V	28.30	3.69	0.00	80.59	94.00	-13.41
4882.00	43.70	PK	H	32.90	6.34	31.78	51.16	74.00	-22.84
4882.00	35.11	AV	H	32.90	6.34	31.78	42.57	54.00	-11.43
4882.00	44.66	PK	V	32.90	6.34	31.78	52.12	74.00	-21.88
4882.00	37.04	AV	V	32.90	6.34	31.78	44.50	54.00	-9.50

7323.00	40.39	PK	H	36.70	6.22	30.97	52.34	74.00	-21.66
7323.00	34.23	AV	H	36.70	6.22	30.97	46.18	54.00	-7.82
7323.00	38.89	PK	V	36.70	6.22	30.97	50.84	74.00	-23.16
7323.00	32.87	AV	V	36.70	6.22	30.97	44.82	54.00	-9.18
9764.00	35.62	PK	H	38.20	8.11	30.86	51.07	74.00	-22.93
9764.00	29.39	AV	H	38.20	8.11	30.86	44.84	54.00	-9.16
9764.00	37.67	PK	V	38.20	8.11	30.86	53.12	74.00	-20.88
9764.00	28.76	AV	V	38.20	8.11	30.86	44.21	54.00	-9.79
96.80	46.29	QP	H	12.20	2.59	27.10	33.98	43.50	-9.52
96.80	40.81	QP	V	12.20	2.59	27.10	28.50	43.50	-15.00
High Channel (2480)									
2480.00	60.22	PK	H	28.00	3.65	0.00	91.87	114.00	-22.13
2480.00	58.33	AV	H	28.00	3.65	0.00	89.98	94.00	-4.02
2480.00	58.88	PK	V	28.00	3.65	0.00	90.53	114.00	-23.47
2480.00	58.19	AV	V	28.00	3.65	0.00	89.84	94.00	-4.16
2483.50	10.78	PK	H	28.70	3.62	0.00	43.10	74.00	-30.90
2483.50	5.79	AV	H	28.70	3.62	0.00	38.11	54.00	-15.89
2483.50	10.45	PK	V	28.70	3.62	0.00	42.77	74.00	-31.23
2483.50	4.26	AV	V	28.70	3.62	0.00	36.58	54.00	-17.42
4960.00	45.25	PK	H	32.80	6.17	31.78	52.44	74.00	-21.56
4960.00	35.35	AV	H	32.80	6.17	31.78	42.54	54.00	-11.46
4960.00	44.03	PK	V	32.80	6.17	31.78	51.22	74.00	-22.78
4960.00	39.10	AV	V	32.80	6.17	31.78	46.29	54.00	-7.71
7440.00	39.67	PK	H	36.80	6.26	30.97	51.76	74.00	-22.24
7440.00	33.27	AV	H	36.80	6.26	30.97	45.36	54.00	-8.64
7440.00	38.35	PK	V	36.80	6.26	30.97	50.44	74.00	-23.56
7440.00	32.93	AV	V	36.80	6.26	30.97	45.02	54.00	-8.98
96.80	46.07	QP	H	12.20	2.59	27.10	33.76	43.50	-9.74
96.80	41.92	QP	V	12.20	2.59	27.10	29.61	43.50	-13.89

- Note: 1. Result Level = Read Level + Antenna Factor + Cable loss - PRM Factor  
 2. If Peak Result comply with QP limit, QP Result is deemed to comply with QP limit  
 3. For fundamental frequency test: RBW=3MHz VBW=10MHz Peak detector for PK value ,  
 RBW=3MHz VBW=10MHz AV detector for AV value.

## 5. Antenna Requirements

### 5.1 Limit

For intentional device, according to FCC 47 CFR Section 15.203, an intentional radiator shall be designed to ensure that no antenna other than that furnished by the responsible party shall be used with the device. And according to FCC 47 CFR Section 15.249 (b), if transmitting antennas of directional gain greater than 6dBi are used, the power shall be reduced by the amount in dB that the directional gain of the antenna exceeds 6dBi.

### 5.2 Result

The EUT has an internal chip antenna permanently soldering on the printed circuit board, which complied with 15.203, the maximum gain was 0dBi.

## 6. Power Line Conducted Emission

### 6.1 Test equipment

Item	Equipment	Manufacturer	Model No.	Serial No.	Cal Due.	Cal. Interval
1	Test Receiver	R&S	ESCI	101308	2014/12/26	1 Year
2	LISN 1	AFJ	LS16	16011103219	2014/12/28	1 Year
3	LISN 2	R&S	ESH2-Z5	100309	2014/12/28	1 Year
4	Pulse Limiter	MTS-systemtechnik	MTS-IMP-136	261115-010-0024	2014/12/28	1 Year

### 6.2 Block diagram of test setup

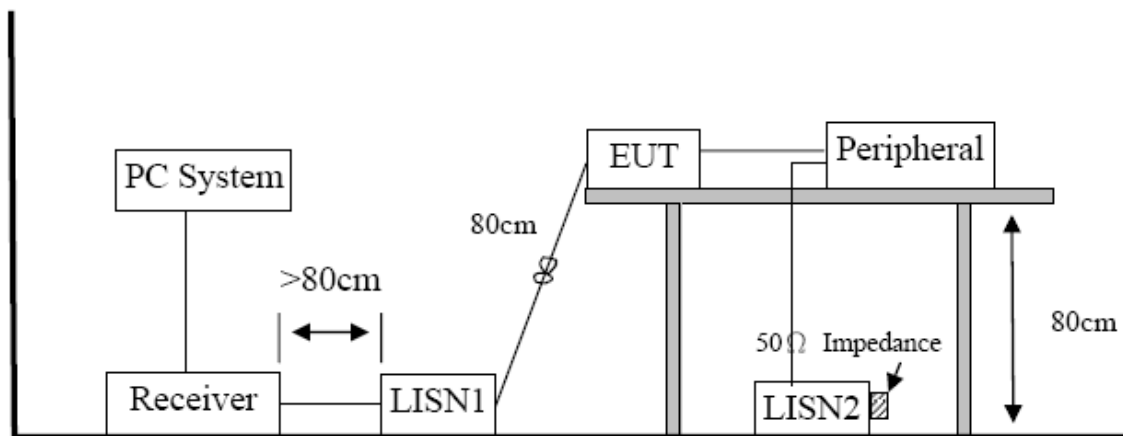



### 6.3 Power Line Conducted Emission Limits(Class B)

Frequency	Quasi-Peak Level dB(μV)	Average Level dB(μV)
150kHz ~ 500kHz	66 ~ 56*	56 ~ 46*
500kHz ~ 5MHz	56	46
5MHz ~ 30MHz	60	50

Note 1: \* Decreasing linearly with logarithm of frequency.

Note 2: The lower limit shall apply at the transition frequencies

### 6.4 Test Procedure

The EUT and Support equipment, if needed, were put placed on a non-metallic table, 80cm above the ground plane. Configuration EUT to simulate typical usage as described in clause 2.4 and test equipment as described in clause 10.2 of this report. All I/O cables were positioned to simulate typical actual usage as per ANSI C63.4: 2009. All support equipment power received from a second LISN. Emissions were measured on each current carrying line of the EUT using an EMI Test Receiver connected to the LISN powering the EUT. The Receiver scanned from 150 kHz to 30MHz for emissions in each of the test modes. During the above scans, the emissions were maximized by cable manipulation. The test mode(s) described in clause 2.4 were scanned during the preliminary test. After the preliminary scan, we found the test mode producing the highest emission level. The EUT configuration and worse cable configuration of the above highest emission levels were recorded for reference of the final test. EUT and support equipment were set up on the test bench as per the configuration with highest emission level in the preliminary test. A scan was taken on both power lines, Neutral and Line, recording at least the six highest emissions. Emission frequency and amplitude were recorded into a computer in which correction factors were used to calculate the emission level and compare reading to the applicable limit. The test data of the worst-case condition(s) was recorded. The bandwidth of test receiver is set at 9 KHz.

### 6.5 Test Result

**PASS.** (See below detailed test result)

EUT:	Afterglow Wireless Controller for PS3 (Controller)	Model No.:	PL-6422BT
Temperature:	24°C	Relative Humidity:	55%
Probe:	N	Test Power:	DC 5V Via PC USB Port Supply
Standard:	(CE)FCC PART 15 class B_QP	Test Result:	Pass
Test Mode:	TX	Test By:	Rock
Note:			

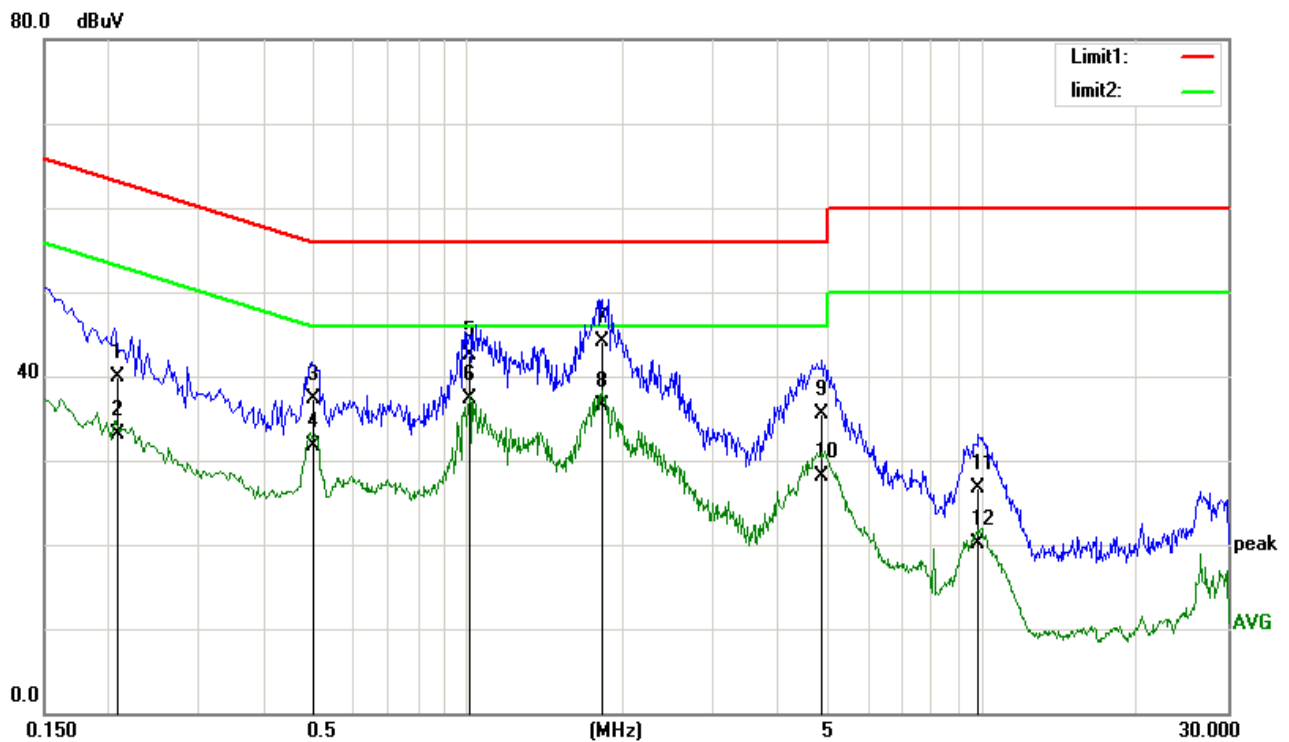

No.	Frequency (MHz)	Reading (dBuV)	Correct Factor(dB)	Result (dBuV)	Limit (dBuV)	Margin (dB)	Remark
1	0.2097	28.57	11.26	39.83	63.21	-23.38	QP
2	0.2097	21.86	11.26	33.12	53.21	-20.09	AVG
3	0.5000	27.10	10.18	37.28	56.00	-18.72	QP
4	0.5000	21.48	10.18	31.66	46.00	-14.34	AVG
5	1.0110	32.48	10.09	42.57	56.00	-13.43	QP
6	1.0110	27.29	10.09	37.38	46.00	-8.62	AVG
7	1.8299	33.94	10.18	44.12	56.00	-11.88	QP
8	1.8299	26.34	10.18	36.52	46.00	-9.48	AVG
9	4.8947	25.00	10.47	35.47	56.00	-20.53	QP
10	4.8947	17.69	10.47	28.16	46.00	-17.84	AVG
11	9.8067	15.88	10.78	26.66	60.00	-33.34	QP
12	9.8067	9.38	10.78	20.16	50.00	-29.84	AVG

EUT:	Afterglow Wireless Controller for PS3 (Controller)	Model No.:	PL-6422BT
Temperature:	24°C	Relative Humidity:	55%
Probe:	L1	Test Power:	DC 5V Via PC USB Port Supply
Standard:	(CE)FCC PART 15 class B_QP	Test Result:	Pass
Test Mode:	TX	Test By:	Rock
Note:			

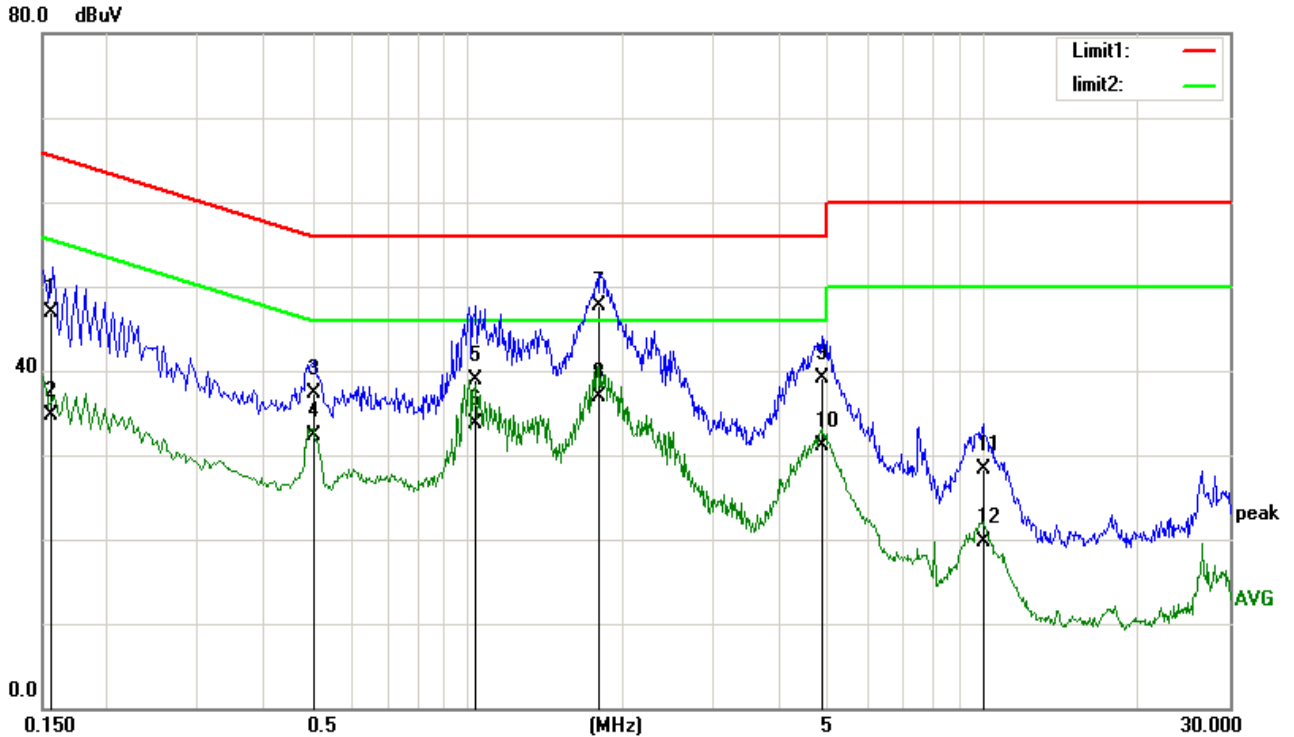

No.	Frequency (MHz)	Reading (dBuV)	Correct Factor(dB)	Result (dBuV)	Limit (dBuV)	Margin (dB)	Remark
1	0.1551	35.08	11.76	46.84	65.72	-18.88	QP
2	0.1551	22.95	11.76	34.71	55.72	-21.01	AVG
3	0.5014	27.19	10.18	37.37	56.00	-18.63	QP
4	0.5014	22.12	10.18	32.30	46.00	-13.70	AVG
5	1.0389	28.77	10.09	38.86	56.00	-17.14	QP
6	1.0389	23.54	10.09	33.63	46.00	-12.37	AVG
7	1.8083	37.45	10.18	47.63	56.00	-8.37	QP
8	1.8083	26.75	10.18	36.93	46.00	-9.07	AVG
9	4.8624	28.68	10.46	39.14	56.00	-16.86	QP
10	4.8624	20.64	10.46	31.10	46.00	-14.90	AVG
11	10.0186	17.44	10.79	28.23	60.00	-31.77	QP
12	10.0186	8.91	10.79	19.70	50.00	-30.30	AVG

## 7.EUT TEST PHOTO

### Conducted Measurement Photos



### Radiated Measurement Photos (Below 1GHz)



**Radiated Measurement Photos (Above 1GHz)**

**EUT PHOTO**





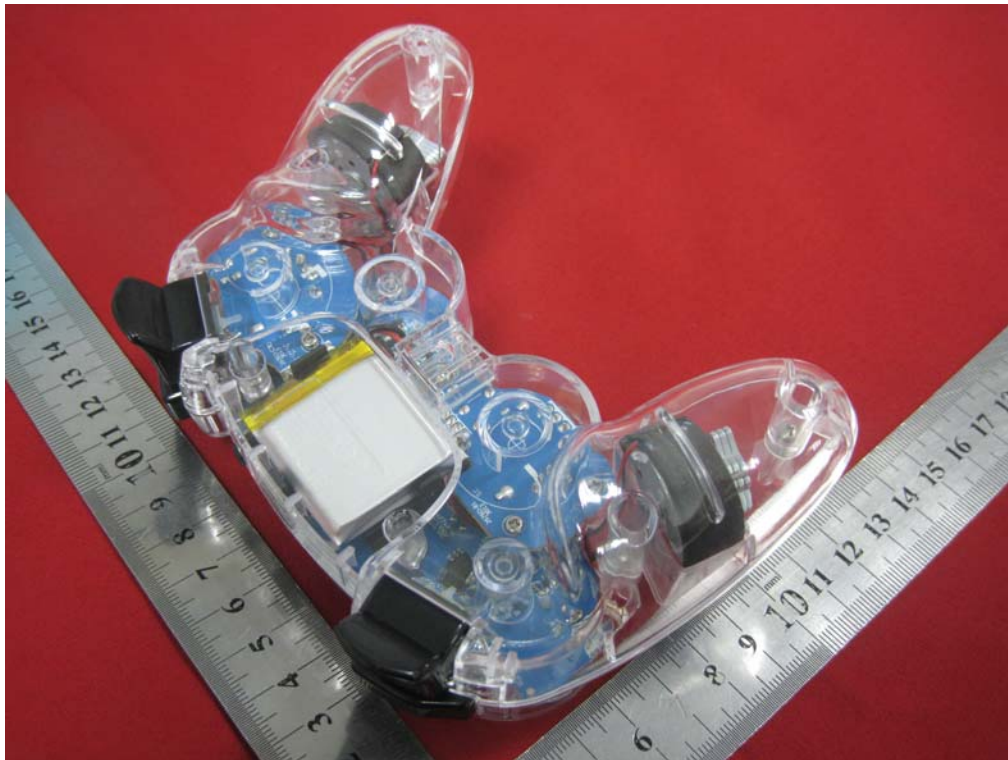

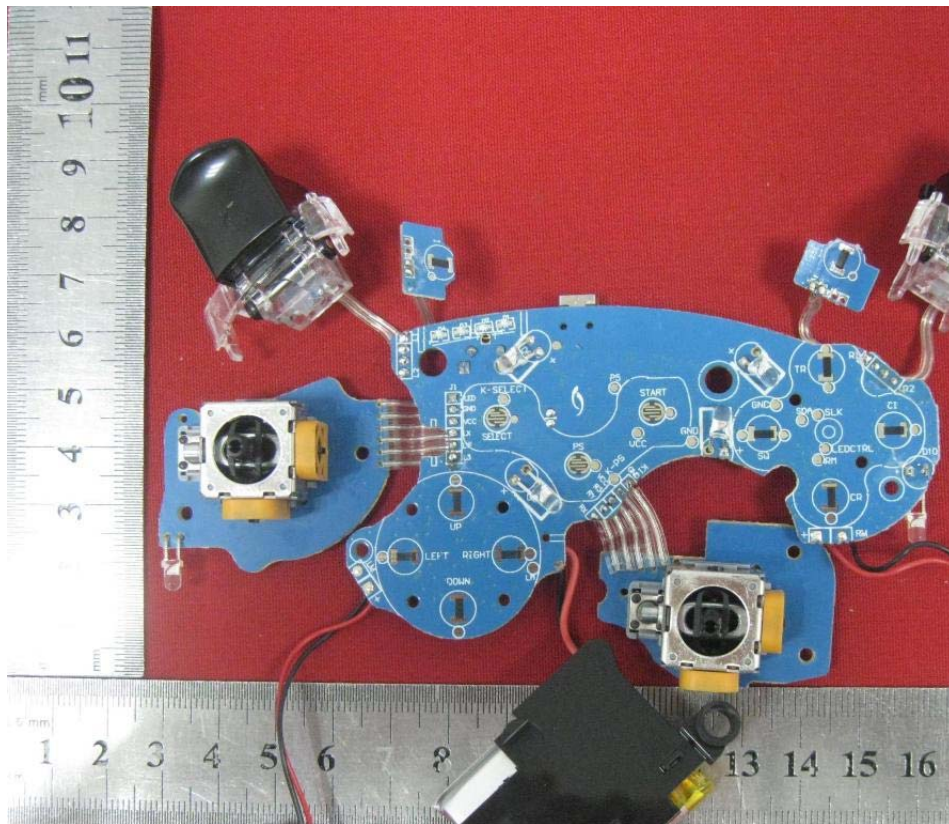
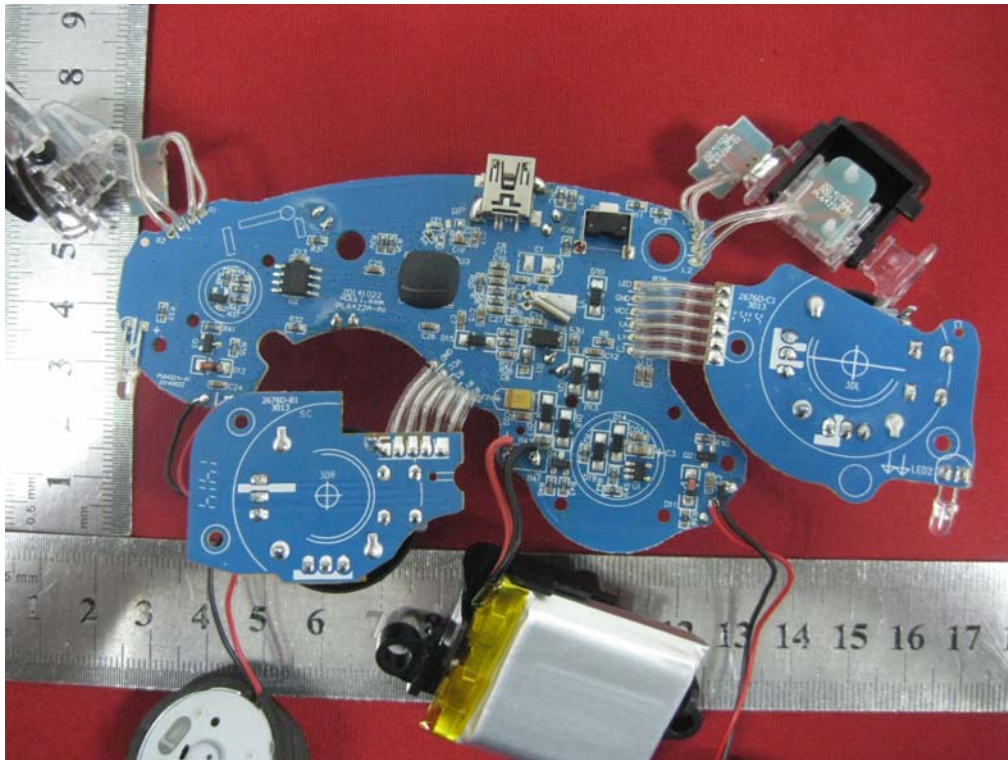

**END OF REPORT**