

FCC CERTIFICATION TEST REPORT FOR

FCC ID: X5B-PL6422A1

Report Reference No.....: 14FAB07013 11

Date of issue: 2014-07-24

Testing Laboratory.....: ATT Product Service Co., Ltd.

Address.....: No. 3, ChangLianShan Industrial Park, ChangAn Town,
DongGuan City, GuangDong, China.

Applicant's name: PERFORMANCE DESIGNED PRODUCTS, LLC

Address.....: 14144 Ventura Blvd,Suite 200,Sherman Oaks,CA 91423
U.S.A

Manufacturer: PERFORMANCE DESIGNED PRODUCTS, LLC

Test specification:

Test item description.....: Afterglow Wireless Controller for PS3 (Controller)

Trade Mark.....: N/A

Model/Type reference: PL-6422A

Ratings.....: 3.7V d.c (Rechargeable Battery)

Responsible Engineer

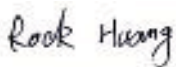

(Rock Huang/ Engineer)

Approved by



(Tomy Wu /EMC Manager)

TABLE OF CONTENTS

TEST REPORT DECLARE	3
1.Summary of test Standards and results.....	4
2.General test information	5
2.1 ACCREDITATIONS	5
2.2Description of EUT	5
2.3Accessories of EUT	5
2.4Assistant equipment used for test.....	5
2.5Block diagram of EUT configuration for test.....	6
2.6Test environment conditions.....	6
2.7Measurement uncertainty.....	6
3. 20dB Bandwidth.....	7
3.1 Test equipment.....	7
3.2 Block diagram of test setup	7
3.3 Applicable Standard.....	7
3.4 Test Procedure	7
3.5 Test Result	8
3.6 Original test data	8
4. Radiated emission.....	10
4.1 Test equipment.....	10
4.2 Block diagram of test setup	10
4.3 Limit.....	11
4.4 Test Procedure	13
4.5 Test result.....	13
5. Antenna Requirements.....	16
5.1 Limit.....	16
5.2 Result	16
6.Power Line Conducted Emission.....	16
6.1 Test equipment.....	16
6.2 Block diagram of test setup	16
6.3 Power Line Conducted Emission Limits(Class B).....	17
6.4 Test Procedure	17
6.5 Test Result	18

TEST REPORT DECLARE

Applicant	:	PERFORMANCE DESIGNED PRODUCTS, LLC
Address	:	14144 Ventura Blvd,Suite 200,Sherman Oaks,CA 91423 U.S.A
Equipment under Test	:	Afterglow Wireless Controller for PS3 (Controller)
Model No	:	PL-6422A
Trade Mark	:	--
Manufacturer	:	PERFORMANCE DESIGNED PRODUCTS, LLC
Address	:	14144 Ventura Blvd,Suite 200,Sherman Oaks,CA 91423 U.S.A

Test Standard Used: FCC Rules and Regulations Part 15 Subpart C: 2010

Test procedure used: ANSI C63.10:2009; ANSI C63.4: 2009
FCC Public Notice DA 00-705

FCC ID: X5B-PL6422A1

We Declare:

The equipment described above is tested by ATT Product Service Co., Ltd. and in the configuration tested the equipment complied with the standards specified above. The test results are contained in this test report and ATT Product Service Co., Ltd. is assumed of full responsibility for the accuracy and completeness of these tests.

After test and evaluation X/Y/Z axis of the EUT. will record worst case in this report. our opinion is that the equipment provided for test compliance with the requirement of the above FCC standards.

Report No:	14FAB07013 11		
Date of Test:	2014-07-15 to 2014-07-23	Date of Report:	2014-07-24

Note: This report applies to above tested sample only. This report shall not be reproduced in parts without written approval of ATT Product Service Co., Ltd.

1.Summary of test Standards and results

The EUT have been tested according to the applicable standards as referenced below.

Description of Test Item	Standard	Results
20dB Bandwidth	&15.215(c) ANSI C63.10 :2009	PASS
Radiated Emission	15.209,&15.205,&15.249 ANSI C63.10 :2009	PASS
Conducted Emissions	&15.207(a) ANSI C63.10 :2009	PASS
Antenna requirement	&15.203	PASS
Outside of Band Emission (50dB attenuation)	&15.249(d)	PASS

Note:

N/A: the EUT was powered by DC battery in normal use condition

2.General test information

2.1 ACCREDITATIONS

The measuring facility of laboratories has been authorized or registered by the following approval agencies.

USA **FCC** **Registration Number :923232**
Canada **INDUSTRY CANADA** **Registration Number 11033A**

2.2Description of EUT

EUT* Name	:	Afterglow Wireless Controller for PS3 (Controller)
Model Number	:	PL-6422A
Trade Mark	:	--
EUT function description	:	Please reference user manual of this device
Power supply	:	3.7V d.c
Operation frequency	:	2412MHz -2475MHz
Modulation	:	GFSK
Data rate	:	1Mbps
Antenna Type	:	built-in antenna, maximum PK gain:0dBi
Date of Receipt	:	2014-07-09
Sample Type	:	Series production

2.3Accessories of EUT

Description of Accessories	Manufacturer	Model number or Type	Other
/	/	/	/

2.4Assistant equipment used for test

Description of Assistant equipment	Manufacturer	Model number or Type	FCCID / FCC DOC	Other
PS3 Game Machine	Sony	CECH-4006B	VOC	03-27445859-56363 27-CECH-4006B
TV	OLYMP	14"TV	VOC	--

2.5 Block diagram of EUT configuration for test

Tested mode, channel, information		
Test Mode	Channel	Frequency (MHz)
Tx Mode	CH0	2412
	CH31	2440
	CH63	2475

2.6 Test environment conditions

During the measurement the environmental conditions were within the listed ranges:

Temperature range:	21-25°C
Humidity range:	40-75%
Pressure range:	86-106kPa

2.7 Measurement uncertainty

Test Item	Uncertainty
Uncertainty for Conduction emission test	2.44dB
Uncertainty for Radiation Emission test (150KHz-30MHz)	3.21dB
Uncertainty for Radiation Emission test (30MHz-200MHz)	3.42 dB (Polarize: V)
	3.52 dB (Polarize: H)
Uncertainty for Radiation Emission test (200MHz-1GHz)	3.52 dB (Polarize: V)
	3.54 dB (Polarize: H)
Uncertainty for Radiation Emission test (1GHz to 25GHz)	4.20 dB (Polarize: V)
	4.20 dB (Polarize: H)
Uncertainty for radio frequency	1×10 ⁻⁹
Uncertainty for conducted RF Power	0.65dB

Note: This uncertainty represents an expanded uncertainty expressed at approximately the 95% confidence level using a coverage factor of k=2.

3. 20dB Bandwidth

3.1 Test equipment

Item	Equipment	Manufacturer	Model No.	Serial No.	Cal Due.	Cal. Interval
1	EMI Test Receiver	R&S	ESCI	101307	2014/12/26	1Y
2	Attenuator	Mini-Circuits	BW-S10W2	101109	2014/12/27	1Y
3	RF Cable	Micable	C10-01-01-1	100309	2014/12/27	1Y

3.2 Block diagram of test setup



3.3 Applicable Standard

Intentional radiators operating under the alternative provisions to the general emission limits, as contained in §§ 15.217 through 15.257 and in Subpart E of this part, must be designed to ensure that the 20 dB bandwidth of the emission, or whatever bandwidth may otherwise be specified in the specific rule section under which the equipment operates, is contained within the frequency band designated in the rule section under which the equipment is operated...

3.4 Test Procedure

1. Check the calibration of the measuring instrument using either an internal calibrator or a known signal from an external generator.
2. Position the EUT on the test table without connection to measurement instrument. Turn on the EUT. Then set it to any one convenient frequency within its operating range. Set a reference level on the measuring instrument equal to the highest peak value.
3. Measure the frequency difference of two frequencies that were attenuated 20 dB from the reference level. Record the frequency difference as the emission bandwidth.
4. Repeat above procedures until all frequencies measured were complete..

3.5 Test Result

EUT: Afterglow Wireless Controller for PS3 (Controller)		M/N: PL-6422A			
Mode	Freq (MHz)	Result (MHz)	Limit (MHz)	Margin (MHz)	Conclusion
Tx	2412	1.036	/	/	PASS
	2440	1.084	/	/	PASS
	2475	1.048	/	/	PASS
Test Date : 2014-07-16			Test Engineer : Bin Jang		

3.6 Original test data

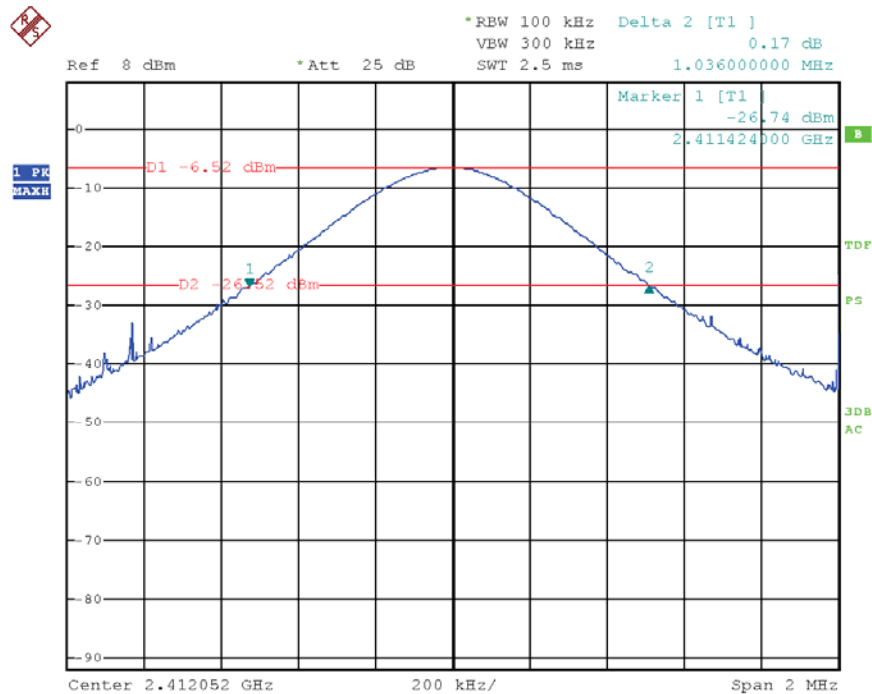

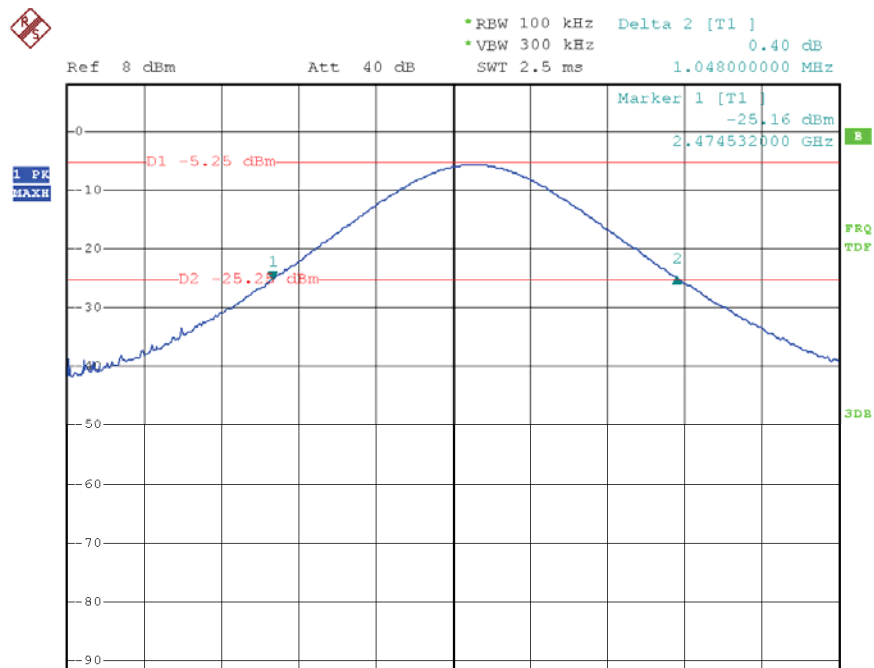
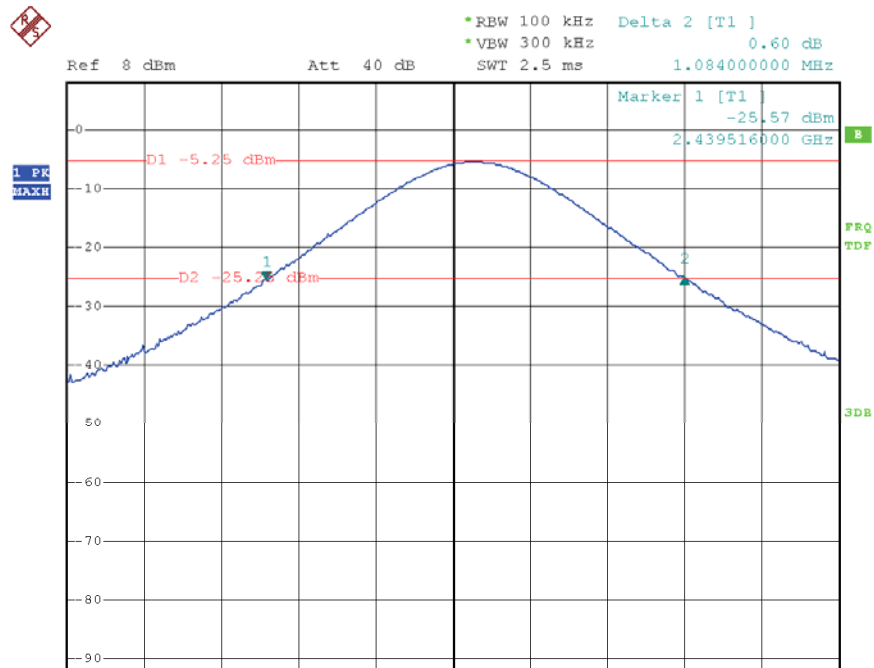

4. Radiated emission

4.1 Test equipment

Item	Equipment	Manufacturer	Model No.	Serial No.	Cal Due.	Cal. Interval
1	EMI Test Receiver	R&S	ESCI	101307	2014/12/26	1Y
2	Spectrum analyzer	Agilent	E4407B	US40240708	2015/07/11	1Y
3	Loop antenna	Chase	HLA6120	20129	2014/12/27	1Y
4	Trilog Broadband Antenna	Schwarzbeck	VULB9163	9163-462	2014/12/27	1Y
5	Double Ridged Horn Antenna	R&S	HF907	100276	2014/12/27	1Y
6	Pre-Amplifier	R&S	SCU-01	10049	2014/12/27	1Y
7	Pre-amplifier	A.H.	PAM0-0118	360	2014/12/27	1Y
8	RF Cable	R&S	R01	10403	2014/12/27	1Y
9	RF Cable	R&S	R02	10512	2014/12/27	1Y
10	Horn Antenna	EMCO	3116	9608-4877	2014/12/27	1Y

4.2 Block diagram of test setup

In 3m Anechoic Chamber Test Setup Diagram for below 1GHz

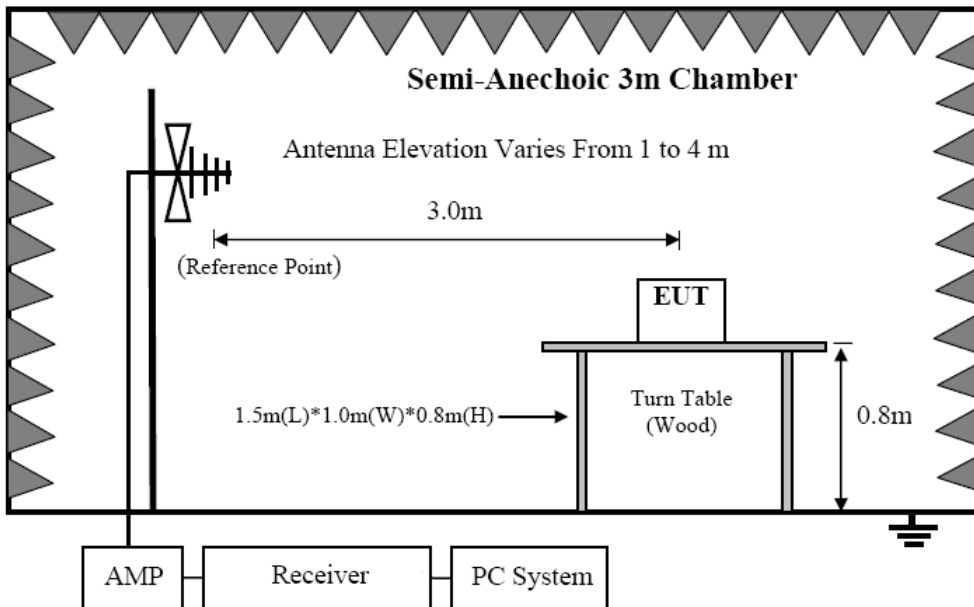

In 3m Anechoic Chamber Test Setup Diagram for frequency above 1GHz

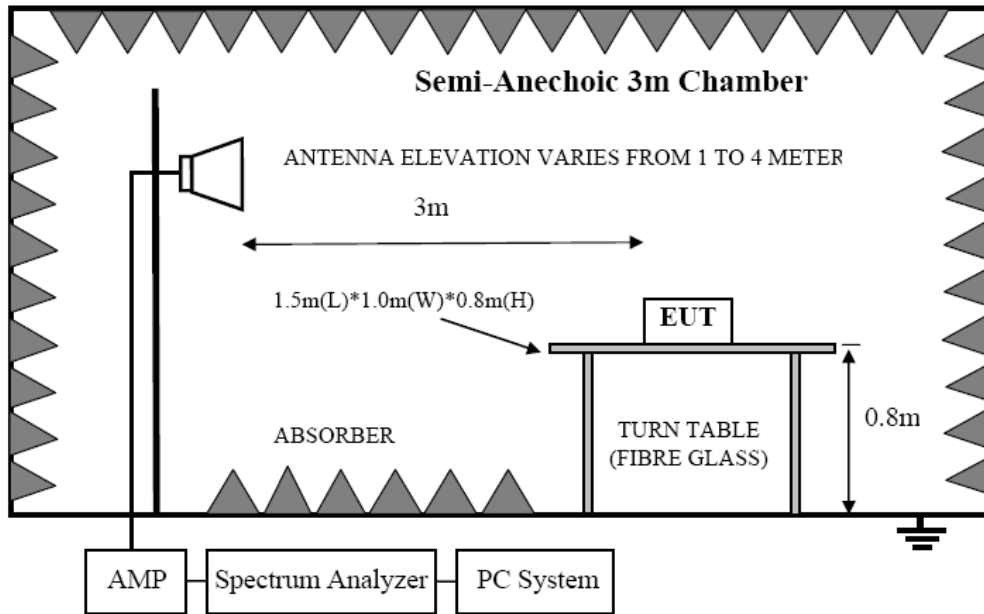

Note: For harmonic emissions test a appropriate high pass filter was inserted in the input port of AMP.

4.3 Limit

4.3.1 FCC 15.205 Restricted frequency band

MHz	MHz	MHz	GHz
0.090 - 0.110	16.42 - 16.423	399.9 - 410	4.5 - 5.15
¹ 0.495 - 0.505	16.69475 - 16.69525	608 - 614	5.35 - 5.46
2.1735 - 2.1905	16.80425 - 16.80475	960 - 1240	7.25 - 7.75
4.125 - 4.128	25.5 - 25.67	1300 - 1427	8.025 - 8.5
4.17725 - 4.17775	37.5 - 38.25	1435 - 1626.5	9.0 - 9.2
4.20725 - 4.20775	73 - 74.6	1645.5 - 1646.5	9.3 - 9.5
6.215 - 6.218	74.8 - 75.2	1660 - 1710	10.6 - 12.7
6.26775 - 6.26825	108 - 121.94	1718.8 - 1722.2	13.25 - 13.4
6.31175 - 6.31225	123 - 138	2200 - 2300	14.47 - 14.5
8.291 - 8.294	149.9 - 150.05	2310 - 2390	15.35 - 16.2
8.362 - 8.366	156.52475 - 156.52525	2483.5 - 2500	17.7 - 21.4
8.37625 - 8.38675	156.7 - 156.9	2690 - 2900	22.01 - 23.12
8.41425 - 8.41475	162.0125 - 167.17	3260 - 3267	23.6 - 24.0
12.29 - 12.293	167.72 - 173.2	3332 - 3339	31.2 - 31.8
12.51975 - 12.52025	240 - 285	3345.8 - 3358	36.43 - 36.5
12.57675 - 12.57725	322 - 335.4	3600 - 4400	(²)

4.3.2 FCC 15.209 Limit

FREQUENCY MHz	DISTANCE Meters	FIELD STRENGTHS LIMIT	
		$\mu\text{V}/\text{m}$	$\text{dB}(\mu\text{V})/\text{m}$
30 ~ 88	3	100	40.0
88 ~ 216	3	150	43.5
216 ~ 960	3	200	46.0
960 ~ 1000	3	500	54.0
Above 1000	3	74.0 $\text{dB}(\mu\text{V})/\text{m}$ (Peak) 54.0 $\text{dB}(\mu\text{V})/\text{m}$ (Average)	

4.3.2 FCC 15.249 Limit

Fundamental frequency	Field strength of fundamental (millivolts/meter)	Field strength of harmonics (microvolts/meter)
902–928 MHz	50	500
2400–2483.5 MHz	50	500
5725–5875 MHz	50	500
24.0–24.25 GHz	250	2500

4.3.3 Limit for this EUT

The radiated emission tests were performed in the 3 meters test site, using the setup accordance with the ANSI C63.4:2009. The specification used was the FCC 15.209, and FCC 15.249 limits.

4.4 Test Procedure

- (1) EUT was placed on a non-metallic table, 80 cm above the ground plane inside a semi-anechoic chamber.
- (2) Setup EUT and assistant system according clause 2.4 and 8.2
- (3) Test antenna was located 3m from the EUT on an adjustable mast. Below pre-scan procedure was first performed in order to find prominent radiated emissions.
 - (a) Change work frequency or channel of device if practicable.
 - (b) Change modulation type of device if practicable.
 - (c) Change power supply range from 85% to 115% of the rated supply voltage
 - (d) Rotated EUT though three orthogonal axes to determine the attitude of EUT arrangement produces highest emissions
- (4) Spectrum frequency from 9MHz to 25GHz (tenth harmonic of fundamental frequency) was investigated, and no any obvious emission were detected from 9KHz to 30MHz and 18GHz to 25GHz, so below final test was performed with frequency range from 30MHz to 18GHz.
- (5) For final emissions measurements at each frequency of interest, the EUT were rotated and the antenna height was varied between 1m and 4m in order to maximize the emission. Measurements in both horizontal and vertical polarities were made and the data was recorded. In order to find the maximum emission, the relative positions of equipments and all of the interface cables were changed according to ANSI C63.10 2009 on Radiated Emission test.
- (6) For emissions from 30MHz to 1GHz, Quasi-Peak values were measured with EMI Receiver and the bandwidth of Receiver is 120 KHz.
- (7) For emissions above 1GHz, both Peak and Average level were measured with Spectrum Analyzer, and the RBW is set at 1MHz, VBW is set at 3MHz for Peak measure, Detector is at PK; RBW is set at 1MHz VBW is set at 10Hz for Average measure, Detector is at PK..

4.5 Test result

PASS. (See below detailed test result)

According to the recorded data in following table, the EUT complied with the FCC Title 47, Part 15, Subpart C and section 15.205, 15.209 and 15.249, Vertical and Horizontal mode all have been tested , Horizontal mode is the worse case .with the worst margin reading of:

Radiated Emission Test Result

Test Mode:Tx

Test Site	: 3m Chamber	Tested By	: Bin Jiang
Test Date	: 2014-07-16	Model Number	: PL-6422A
EUT	: Afterglow PS3 Wireless Controller (Controller)	Test Mode	: Tx mode CH0,CH31,CH63
Power Supply	: 3.7Vdc	Antenna/Distan	: 3m
Condition	: Temp:24.5'C,Humi:55%		

Frequency (MHz)	Receiver		Rx Antenna		Cable Loss (dB)	Amplifier Gain (dB)	Result Level (dBµV/m)	FCC 15.249	
	Reading (dBµV)	Detector (PK/QP/ AV)	Polar (H/V)	Factor (dB)				Limit (dBµV/m)	Margin (dB)
Low Channel(2412)									
2412	60.68	PK	H	28	3.65	0	92.33	114	21.67
2412	48.81	AV	H	28	3.65	0	80.46	94	13.54
2412	59.12	PK	V	28	3.65	0	90.77	114	23.23
2412	48.52	AV	V	28	3.65	0	80.17	94	13.83
2390	31.48	PK	H	28.4	3.57	0	63.45	74	10.55
2390	15.26	AV	H	28.4	3.57	0	47.23	54	6.77
2390	26.64	PK	V	28.4	3.57	0	58.61	74	15.39
2390	15.61	AV	V	28.4	3.57	0	47.58	54	6.42
2400	30.45	PK	H	28.4	3.57	0	62.42	74	11.58
2400	16.67	AV	H	28.4	3.57	0	48.64	54	5.36
2400	29.38	PK	V	28.4	3.57	0	61.35	74	12.65
2400	16.47	AV	V	28.4	3.57	0	48.44	54	5.56
4824	55.15	PK	H	32.3	5.91	31.78	61.58	74	12.42
4824	37.22	AV	H	32.3	5.91	31.78	43.65	54	10.35
4824	50.04	PK	V	32.3	5.91	31.78	56.47	74	17.53
4824	31.25	AV	V	32.3	5.91	31.78	37.68	54	16.32
7236	44.2	PK	H	36.3	6.34	30.97	55.87	74	18.13
7236	29.61	AV	H	36.3	6.34	30.97	41.28	54	12.72
7236	46.15	PK	V	36.3	6.34	30.97	57.82	74	16.18
7236	29.88	AV	V	36.3	6.34	30.97	41.55	54	12.45
9648	41.68	PK	H	37.9	8.01	30.86	56.73	74	17.27
9648	27.6	AV	H	37.9	8.01	30.86	42.65	54	11.35
9648	40.98	PK	V	37.9	8.01	30.86	56.03	74	17.97
9648	27.11	AV	V	37.9	8.01	30.86	42.16	54	11.84
532	44.07	QP	H	12.8	2.63	27.2	32.3	46	13.7
532	43.27	QP	V	12.8	2.63	27.2	31.5	46	14.5
Middle Channel(2440)									
2440	60.2	PK	H	28	3.65	0	91.85	114	22.15
2440	53.59	AV	H	28	3.65	0	85.24	94	8.76
2440	57.86	PK	V	28	3.65	0	89.51	114	24.49
2440	49.42	AV	V	28	3.65	0	81.07	94	12.93
4880	50.4	PK	H	32.6	6.15	31.78	57.37	74	16.63
4880	32.49	AV	H	32.6	6.15	31.78	39.46	54	14.54

4880	47.58	PK	V	32.6	6.15	31.78	54.55	74	19.45
4880	29.81	AV	V	32.6	6.15	31.78	36.78	54	17.22
7320	45.24	PK	H	36.7	6.22	30.97	57.19	74	16.81
7320	28.18	AV	H	36.7	6.22	30.97	40.13	54	13.87
7320	40.51	PK	V	36.7	6.22	30.97	52.46	74	21.54
7320	26.2	AV	V	36.7	6.22	30.97	38.15	54	15.85
9760	42.04	PK	H	38.2	8.11	30.86	57.49	74	16.51
9760	27	AV	H	38.2	8.11	30.86	42.45	54	11.55
9760	41.39	PK	V	38.2	8.11	30.86	56.84	74	17.16
9760	25.78	AV	V	38.2	8.11	30.86	41.23	54	12.77
532	44.67	QP	H	12.8	2.63	27.2	32.9	46	13.1
532	42.37	QP	V	12.8	2.63	27.2	30.6	46	15.4
High Channel (2475)									
2475	61.07	PK	H	28	3.65	0	92.72	114	21.28
2475	56.69	AV	H	28	3.65	0	88.34	94	5.66
2475	58.9	PK	V	28	3.65	0	90.55	114	23.45
2475	53.76	AV	V	28	3.65	0	85.41	94	8.59
2483.5	34.15	PK	H	28.7	3.62	0	66.47	74	7.53
2483.5	17.32	AV	H	28.7	3.62	0	49.64	54	4.36
2483.5	32.39	PK	V	28.7	3.62	0	64.71	74	9.29
2483.5	14.92	AV	V	28.7	3.62	0	47.24	54	6.76
4950	48.36	PK	H	32.8	6.17	31.78	55.55	74	18.45
4950	29.55	AV	H	32.8	6.17	31.78	36.74	54	17.26
4950	48.09	PK	V	32.8	6.17	31.78	55.28	74	18.72
4950	31.57	AV	V	32.8	6.17	31.78	38.76	54	15.24
7425	41.85	PK	H	36.8	6.26	30.97	53.94	74	20.06
7425	25.39	AV	H	36.8	6.26	30.97	37.48	54	16.52
7425	38.19	PK	V	36.8	6.26	30.97	50.28	74	23.72
7425	24.03	AV	V	36.8	6.26	30.97	36.12	54	17.88
9900	43.25	PK	H	38.4	8.17	30.86	58.96	74	15.04
9900	27.06	AV	H	38.4	8.17	30.86	42.77	54	11.23
9900	40.64	PK	V	38.4	8.17	30.86	56.35	74	17.65
9900	24.36	AV	V	38.4	8.17	30.86	40.07	54	13.93
532	45.17	QP	H	12.8	2.63	27.2	33.4	46	12.6
532	43.57	QP	V	12.8	2.63	27.2	31.8	46	14.2

- Note: 1. Result Level = Read Level + Antenna Factor + Cable loss - PRM Factor
 2. If Peak Result comply with QP limit, QP Result is deemed to comply with QP limit

5. Antenna Requirements

5.1 Limit

For intentional device, according to FCC 47 CFR Section 15.203, an intentional radiator shall be designed to ensure that no antenna other than that furnished by the responsible party shall be used with the device. And according to FCC 47 CFR Section 15.249 (b), if transmitting antennas of directional gain greater than 6dBi are used, the power shall be reduced by the amount in dB that the directional gain of the antenna exceeds 6dBi.

5.2 Result

The EUT has an internal chip antenna permanently soldering on the printed circuit board, which complied with 15.203, the maximum gain was 0dBi.

6. Power Line Conducted Emission

6.1 Test equipment

Item	Equipment	Manufacturer	Model No.	Serial No.	Cal Due.	Cal. Interval
1	Test Receiver	R&S	ESCI	101308	2014/11/26	1 Year
2	LISN 1	AFJ	LS16	16011103219	2014/12/28	1 Year
3	LISN 2	R&S	ESH2-Z5	100309	2014/12/28	1 Year
4	Pulse Limiter	MTS-systemtechnik	MTS-IMP-136	261115-010-0024	2014/12/28	1 Year

6.2 Block diagram of test setup

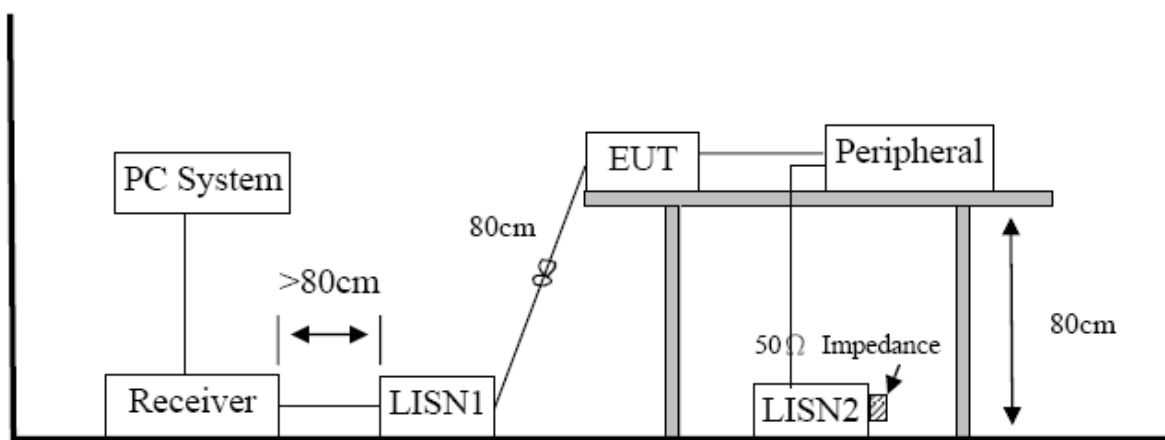

6.3 Power Line Conducted Emission Limits(Class B)

Frequency	Quasi-Peak Level dB(μV)	Average Level dB(μV)
150kHz ~ 500kHz	66 ~ 56*	56 ~ 46*
500kHz ~ 5MHz	56	46
5MHz ~ 30MHz	60	50

Note 1: * Decreasing linearly with logarithm of frequency.

Note 2: The lower limit shall apply at the transition frequencies

6.4 Test Procedure

The EUT and Support equipment, if needed, were put placed on a non-metallic table, 80cm above the ground plane. Configuration EUT to simulate typical usage as described in clause 2.4 and test equipment as described in clause 10.2 of this report. All I/O cables were positioned to simulate typical actual usage as per ANSI C63.4: 2009. All support equipment power received from a second LISN. Emissions were measured on each current carrying line of the EUT using an EMI Test Receiver connected to the LISN powering the EUT. The Receiver scanned from 150 kHz to 30MHz for emissions in each of the test modes. During the above scans, the emissions were maximized by cable manipulation. The test mode(s) described in clause 2.4 were scanned during the preliminary test. After the preliminary scan, we found the test mode producing the highest emission level. The EUT configuration and worse cable configuration of the above highest emission levels were recorded for reference of the final test. EUT and support equipment were set up on the test bench as per the configuration with highest emission level in the preliminary test. A scan was taken on both power lines, Neutral and Line, recording at least the six highest emissions. Emission frequency and amplitude were recorded into a computer in which correction factors were used to calculate the emission level and compare reading to the applicable limit. The test data of the worst-case condition(s) was recorded. The bandwidth of test receiver is set at 9 KHz.

6.5 Test Result

PASS. (See below detailed test result)

EUT:	Afterglow Wireless Controller for PS3 (Controller)	Model No.:	PL-6422A
Temperature:	24°C	Relative Humidity:	55%
Probe:	N	Test Power:	AC 120V/60Hz
Standard:	(CE)FCC PART 15 class B_QP	Test Result:	Pass
Test Mode:	Keeping TX	Test By:	Dylan
Note:	PS3 Mains		

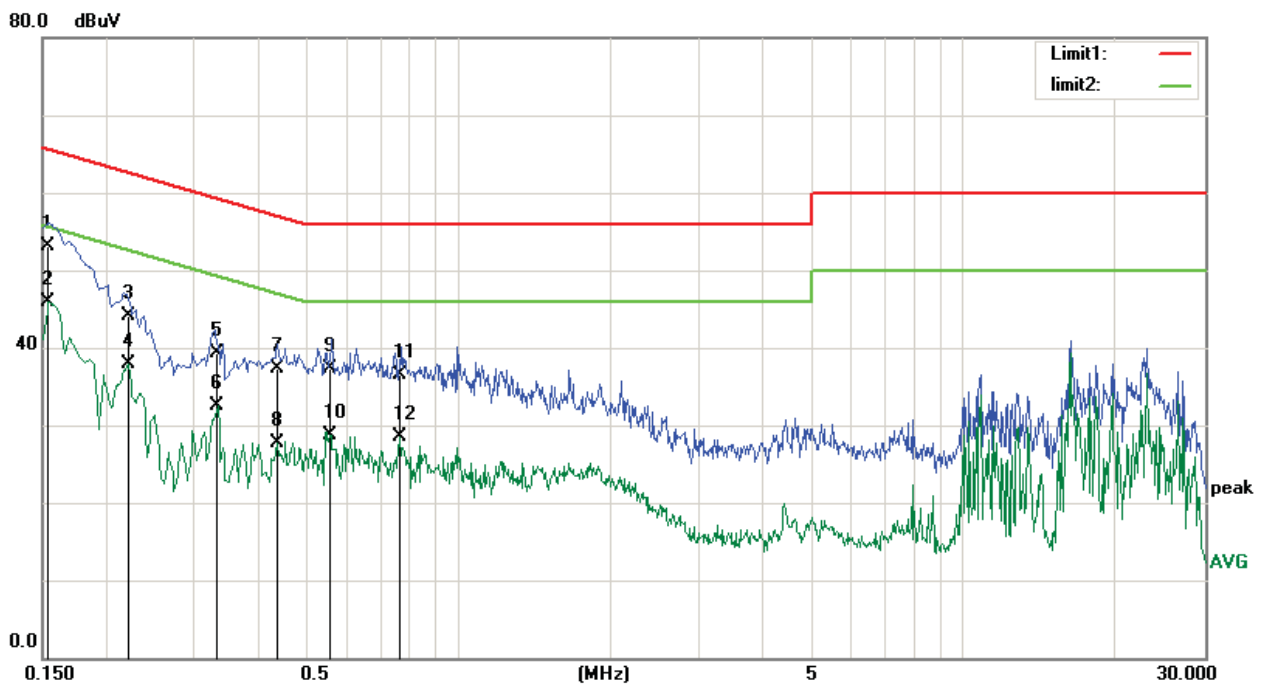

No.	Frequency (MHz)	Reading (dBuV)	Correct Factor (dB)	Result (dBuV)	Limit (dBuV)	Margin (dB)	Remark
1	0.1539	41.57	11.44	53.01	65.78	-12.77	QP
2	0.1539	34.50	11.44	45.94	55.78	-9.84	AVG
3	0.2220	33.05	10.97	44.02	62.74	-18.72	QP
4	0.2220	27.00	10.97	37.97	52.74	-14.77	AVG
5	0.3339	28.81	10.40	39.21	59.35	-20.14	QP
6	0.3339	22.05	10.40	32.45	49.35	-16.90	AVG
7	0.4380	27.10	10.26	37.36	57.10	-19.74	QP
8	0.4380	17.53	10.26	27.79	47.10	-19.31	AVG
9	0.5580	27.20	10.16	37.36	56.00	-18.64	QP
10	0.5580	18.54	10.16	28.70	46.00	-17.30	AVG
11	0.7660	26.36	10.10	36.46	56.00	-19.54	QP
12	0.7660	18.40	10.10	28.50	46.00	-17.50	AVG

EUT:	Afterglow Wireless Controller for PS3 (Controller)	Model No.:	PL-6422A
Temperature:	24°C	Relative Humidity:	55%
Probe:	L1	Test Power:	AC 120V/60Hz
Standard:	(CE)FCC PART 15 class B_QP	Test Result:	Pass
Test Mode:	Keeping TX	Test By:	Dylan
Note:	PS3 Mains		

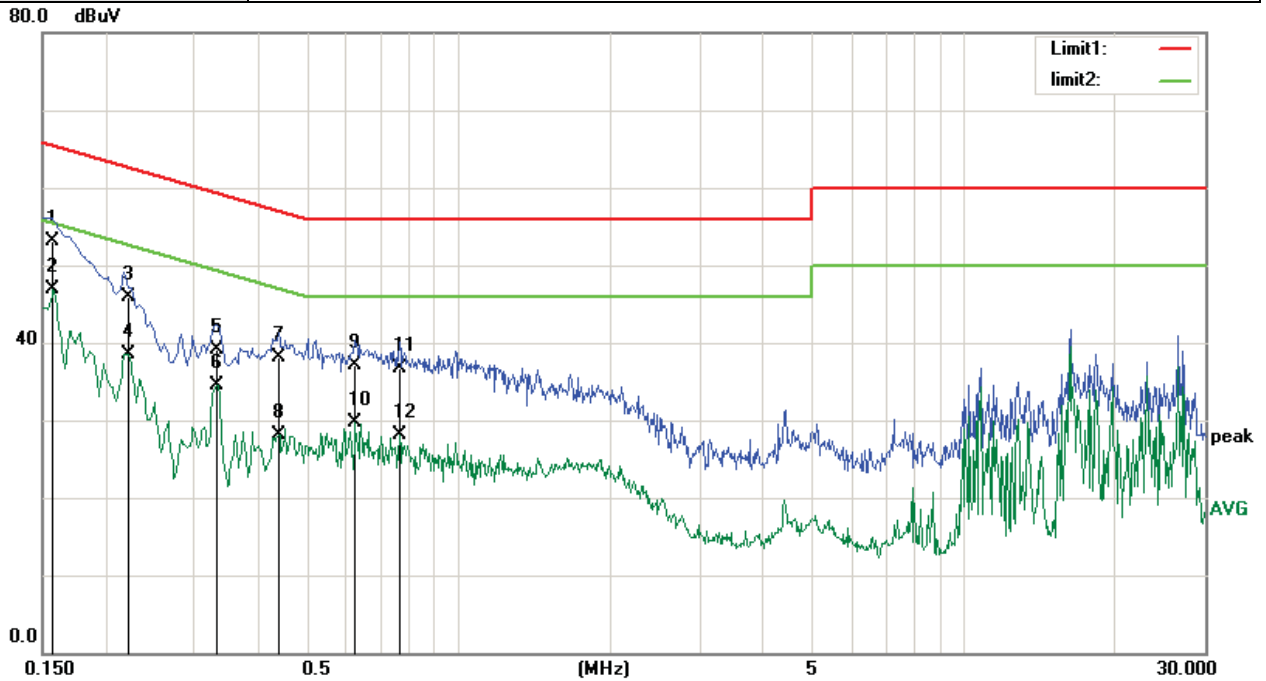

No.	Frequency (MHz)	Reading (dBuV)	Correct Factor (dB)	Result (dBuV)	Limit (dBuV)	Margin (dB)	Remark
1	0.1580	41.61	11.41	53.02	65.56	-12.54	QP
2	0.1580	35.58	11.41	46.99	55.56	-8.57	AVG
3	0.2220	34.91	10.97	45.88	62.74	-16.86	QP
4	0.2220	27.61	10.97	38.58	52.74	-14.16	AVG
5	0.3339	28.80	10.40	39.20	59.35	-20.15	QP
6	0.3339	24.15	10.40	34.55	49.35	-14.80	AVG
7	0.4420	27.92	10.26	38.18	57.02	-18.84	QP
8	0.4420	17.82	10.26	28.08	47.02	-18.94	AVG
9	0.6260	27.01	10.14	37.15	56.00	-18.85	QP
10	0.6260	19.61	10.14	29.75	46.00	-16.25	AVG
11	0.7660	26.61	10.10	36.71	56.00	-19.29	QP
12	0.7660	18.10	10.10	28.20	46.00	-17.80	AVG

END OF REPORT