

# FCC RADIO TEST REPORT

**FCC ID:X5B-878004RWS**  
**IC:8814A-878004RWS**

Report Reference No..... : 16FAB12002 11  
Date of issue ..... : 2016-12-15  
FCC 2.948 No ..... : 923232  
IC Registration Number ..... : 110033A-1  
Testing Laboratory ..... : ATT Product Service Co., Ltd.  
Address ..... : No. 3, ChangLianShan Industrial Park, ChangAn Town,  
DongGuan City, GuangDong, China.

Applicant's name..... : Performance Designed Products, LLC.  
Address..... : 14144 Ventura Blvd, Suite 200 Sherman  
Oaks,CA 91423 U.S.A.  
Manufacturer..... : Performance Designed Products, LLC.  
Address..... : 2300 West Empire Avenue Suite 600 Burbank CA 91504.

Test specification:  
Test item description..... : MASS EFFECT ANDROMEDA CE: NOMAD REMOTE  
CONTROL  
Trade Mark..... : N/A  
Model/Type reference..... : 878-004  
Ratings..... : I/P: 7.4Vdc battery for 5Vdc 1A adapter supply

Responsible Engineer :



Lake Hu

Authorized Signatory:

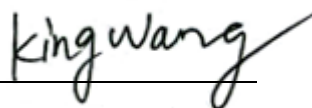

King Wang

## TABLE OF CONTENTS

TEST REPORT DECLARE .....	3
1. Summary of test Standards and results.....	4
2.1. Accretations .....	5
2.2. Description of EUT .....	5
2.3. Accessories of EUT .....	5
2.4. Assistant equipment used for test .....	5
2.5. Block diagram of EUT configuration for test .....	6
2.6. Test environment conditions .....	6
2.7. Measurement uncertainty .....	7
3. 6dB Bandwidth and 99% Occupied Bandwidth .....	7
3.1. Test equipment.....	7
3.2. Block diagram of test setup .....	7
3.3. Limits.....	7
3.4. Test Procedure .....	7
3.5. Test Result.....	8
3.6. Original test data .....	8
4. Maximum Peak Output Power.....	9
4.1. Test equipment.....	9
4.2. Block diagram of test setup .....	9
4.3. Limits.....	9
4.4. Test Procedure .....	9
5. Power Spectral Density .....	10
5.1. Test equipment.....	10
5.2. Block diagram of test setup .....	10
5.3. Limits.....	10
5.5. Test Result.....	11
5.6. Original test data .....	12
6. Spurious Emissions.....	13
6.1. Test equipment.....	13
6.2. Block diagram of test setup .....	13
6.3. Limit.....	14
7. 100 kHz Bandwidth of Frequency Band Edge .....	22
7.1. Test equipment.....	22
7.2. Block diagram of test setup .....	22
7.3. Limit.....	22

7.4. Test Procedure .....	23
7.5. Test result.....	23
8. Conducted Spurious Emissions .....	24
8.1. Test Equipment .....	24
8.2. Limit.....	24
8.3. Test Procedure .....	24
8.4. Test result.....	25
9. Antenna Requirements.....	26
9.1. Limit.....	26
9.2. Result.....	26

## TEST REPORT DECLARE

<b>Applicant</b>	:	Performance Designed Products, LLC.
<b>Address</b>	:	14144 Ventura Blvd, Suite 200 Sherman Oaks, CA 91423 U.S.A.
<b>Equipment under Test</b>	:	MASS EFFECT ANDROMEDA CE: NOMAD REMOTE CONTROL
<b>Model No</b>	:	878-004
<b>Trade Mark</b>	:	N/A
<b>Manufacturer</b>	:	Performance Designed Products, LLC.
<b>Address</b>	:	2300 West Empire Avenue Suite 600 Burbank CA 91504.

**Test Standard Used:** FCC Rules and Regulations Part 15 Subpart C : 2015.

RSS-247 ISSUE 1 May ,2015; RSS-GEN ISSUE 4 NOV 2014

**Test procedure used:** ANSI C63.10:2013, ANSI C63.4:2014, 558074 V03R05.

**We Declare:**

The equipment described above is tested by ATT Product Service Co., Ltd. and in the configuration tested the equipment complied with the standards specified above. The test results are contained in this test report and ATT Product Service Co., Ltd. is assumed of full responsibility for the accuracy and completeness of these tests.

**After test and evaluation, our opinion is that the equipment provided for test compliance with the requirement of the above FCC standards.**

<b>Report No:</b>	16FAB12002 11		
<b>Date of Test:</b>	2016-12-05--2016-12-14	<b>Date of Report:</b>	2016-12-15

Note: This report applies to above tested sample only. This report shall not be reproduced in parts without written approval of ATT Product Service Co., Ltd.

## 1. Summary of test Standards and results

The EUT have been tested according to the applicable standards as referenced below.

Description of Test Item	Standard	Results
6dB Bandwidth And 99% Occupied Bandwidth	FCC Part 15.247 (a)(2) RSS 247:5.2.1	PASS
Peak Output Power	FCC Part 15.247(b)(3) RSS 247:5.4.4	PASS
Power Spectral Density	FCC Part 15.247(e) RSS 247:5.2.2	PASS
Spurious Emissions at Antenna Port	FCC Part 15.247(d) RSS 247:5.5	PASS
Spurious Emissions	FCC Part 15.205, 15.209, FCC Part 15.247(d) RSS 247:5.5	PASS
100 kHz Bandwidth of Frequency Band Edge	FCC Part 15.247(d) RSS 247:5.5	PASS
AC Line Conducted Emissions	FCC Part 15.207 RSS 247:8.8	N/A
Antenna requirement	FCC Part 15: 15.203 RSS-Gen:8.3	PASS

## 2. GENERAL TEST INFORMATION

### 2.1. Accreditations

The measuring facility of laboratories has been authorized or registered by the following approval agencies.

**USA                      FCC    Registration Number :923232**

### 2.2. Description of EUT

EUT* Name	:	MASS EFFECT ANDROMEDA CE: NOMAD REMOTE CONTROL
Model Number	:	878-004
Trade Mark	:	N/A
EUT function description	:	Please reference user manual of this device
Power supply	:	7.4Vdc battery for 5Vdc 1A adapter supply
Radio Specification	:	IEEE802.11g
Operation frequency	:	IEEE 802.11g Mode: 2452MHz
Modulation	:	IEEE 802.11g Mode: OFDM
Antenna Type	:	PCB antenna,maximum PK gain: 2.81dBi
FVIN	:	MakoCar(v0.7.0)
Date of Receipt	:	2016-12-05
Sample Type	:	Series production

Note: EUT is the ab. of equipment under test.

### 2.3. Accessories of EUT

Description of Accessories	Manufacturer	Model number or Type	Other
AC/DC Adapter	Lingdiantong	LDT-24B	FCC DoC

### 2.4. Assistant equipment used for test

Description of Assistant equipment	Manufacturer	Model number or Type	Other

## 2.5. Block diagram of EUT configuration for test



EUT was connected to control to a special test jig provided by manufacturer which has a standard RSS-232 connector to connect to Notebook, and the Notebook will run a special test software "MP\_v1.1.1" provided by manufacturer to control EUT work in test mode as blow table.

Tested mode, channel, and data rate information			
Mode	data rate (Mbps) (see Note)	Channel	Frequency (MHz)
IEEE 802.11g	6	Middle: CH 9	2452
Note: According exploratory test, EUT will have maximum output power in those data rate, so those data rate were used for all test.			

## 2.6. Test environment conditions

During the measurement the environmental conditions were within the listed ranges:

Temperature range:	21-25°C
Humidity range:	40-75%
Pressure range:	86-106kPa

## 2.7. Measurement uncertainty

Test Item	Uncertainty
Uncertainty for Conduction emission test	2.44dB
Uncertainty for Radiation Emission test (150KHz-30MHz)	3.21dB
Uncertainty for Radiation Emission test (30MHz-1GHz)	3.14 dB (Polarize: V)
	3.16 dB (Polarize: H)
Uncertainty for Radiation Emission test (1GHz to 25GHz)	2.08dB(Polarize: V)
	2.56dB (Polarize: H)
Uncertainty for radio frequency	1×10 <sup>-9</sup>
Uncertainty for conducted RF Power	0.65dB

Note: This uncertainty represents an expanded uncertainty expressed at approximately the 95% confidence level using a coverage factor of k=2.

## 3. 6dB Bandwidth and 99% Occupied Bandwidth

### 3.1. Test equipment

Item	Equipment	Manufacturer	Model No.	Serial No.	Calibrated until	Calibrated Date
1	Spectrum analyzer	KEYSIGHT	N9010A	MY55150427	2017/05/05	2016/05/06
2	Attenuator	Mini-Circuits	BW-S10W2	101109	2016/12/19	2015/12/20
3	RF Cable	Micable	C10-01-01-1	100309	2016/12/19	2015/12/20

### 3.2. Block diagram of test setup

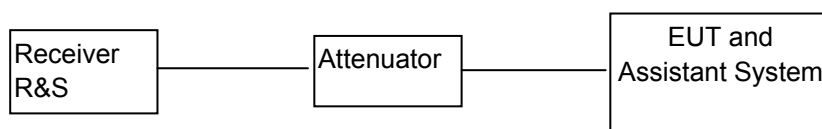

### 3.3. Limits

For direct sequence systems, the minimum 6dB bandwidth shall be at least 500 KHz

### 3.4. Test Procedure

- (1) Check the calibration of the measuring instrument using either an internal calibrator or a known signal from an external generator.
- (2) Position the EUT without connection to measurement instrument. Turn on the EUT and connect it to measurement instrument. Then set it to any one convenient frequency within its operating range. Set a reference level on the measuring instrument equal to the highest peak value.



- (3) Measure the frequency difference of two frequencies that were attenuated 6 dB from the reference level. Record the frequency difference as the emission bandwidth.
- (4) Repeat above procedures until all frequencies measured were complete.

### 3.5. Test Result

EUT Set Mode	CH or Frequency	6 dB bandwidth	99% dB bandwidth	Limt	Conclusion
		Result (MHz)	Result (MHz)		
IEEE 802.11g	CH 9	16.34	16.458	>500KHz	PASS

### 3.6. Original test data

802.11 g Mode 2452MHz

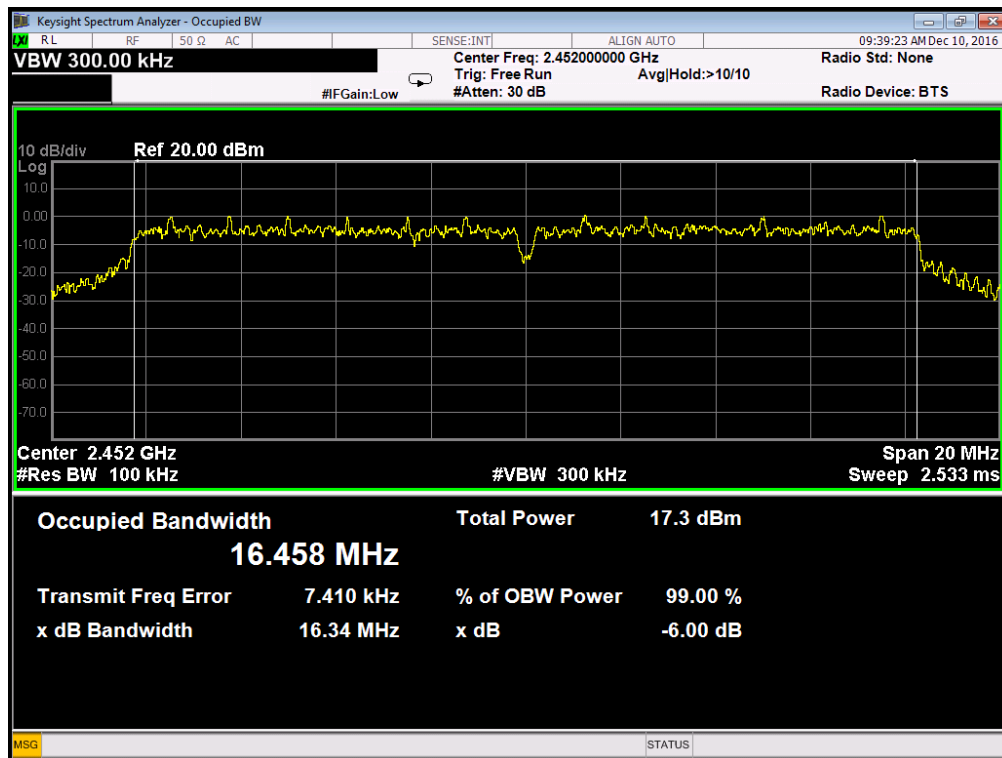

## 4. Maximum Peak Output Power

### 4.1. Test equipment

Item	Equipment	Manufacturer	Model No.	Serial No.	Calibrated until	Calibrated Date
1	Power meter	Agilent	E4417A	MY45100473	2016/12/19	2015/12/20
2	Wireband Power sensor	Agilent	E4427A	MY5100041	2016/12/19	2015/12/20
3	RF Cable	Micable	C10-01-01-1	100309	2016/12/19	2015/12/20

### 4.2. Block diagram of test setup

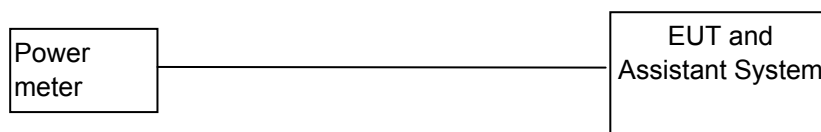

### 4.3. Limits

For systems using digital modulation in the 902-928 MHz, 2400-2483.5 MHz bands: 1 Watt. If transmitting antennas of directional gain greater than 6 dBi are used, the conducted output power from the intentional radiator shall be reduced below the stated values as appropriate, by the amount in dB that the directional gain of the antenna exceeds 6 dBi.

### 4.4. Test Procedure

1. Place the EUT on a bench and set it in transmitting mode.
2. A wide band power meter with a matched thermocouple detector was used to directly measure the output power from the RF output port of the EUT in continuously transmitting mode.
3. The measurement shall be repeated at the lowest, the middle, and the highest channel of the stated frequency range.

### 4.5. TEST RESULT

EUT Set Mode	Limit	Conclusion	CH	Result(dBm)
				Peak
IEEE 802.11g	30dBm	PASS	CH 9	15.73

## 5. Power Spectral Density

### 5.1. Test equipment

Item	Equipment	Manufacturer	Model No.	Serial No.	Calibrated until	Calibrated Date
1	Spectrum analyzer	KEYSIGHT	N9010A	MY55150427	2017/05/05	2016/05/06
2	Attenuator	Mini-Circuits	BW-S10W2	101109	2016/12/19	2015/12/20
3	RF Cable	Micable	C10-01-01-1	100309	2016/12/19	2015/12/20

### 5.2. Block diagram of test setup



### 5.3. Limits

For digitally modulated systems, the power spectral density conducted from the intentional radiator to the antenna shall not be greater than 8dBm in any 3 kHz band during any time interval of continuous transmission.

#### 5.4. TEST PROCEDURE

1. Check the calibration of the measuring instrument using either an internal calibrator or a known signal from an external generatorl.
2. Position the EUT was set without connection to measurement instrument. Turn on the EUT and connect its antenna terminal to measurement instrument via a low loss cable. Then set it to any one measured frequency within its operating range, and make sure the instrument is operated in its linear range
3. According to KDB 558074 D01 DTS Meas Guidance v03, set the RBW = 3 kHz, VBW = 30 kHz, Set the span to 1.5 times the DTS channel bandwidth.
4. Use the peak marker function to determine the maximum power level in any 3 kHz band segment within the fundamental EBW

#### 5.5. Test Result

EUT Set Mode	CH or Frequency	Result	Limit: <dBm/3KHz	Conclusion
IEEE 802.11g	CH 9	-14.93	8	PASS

### 5.6. Original test data

802.11 g Mode 2452MHz

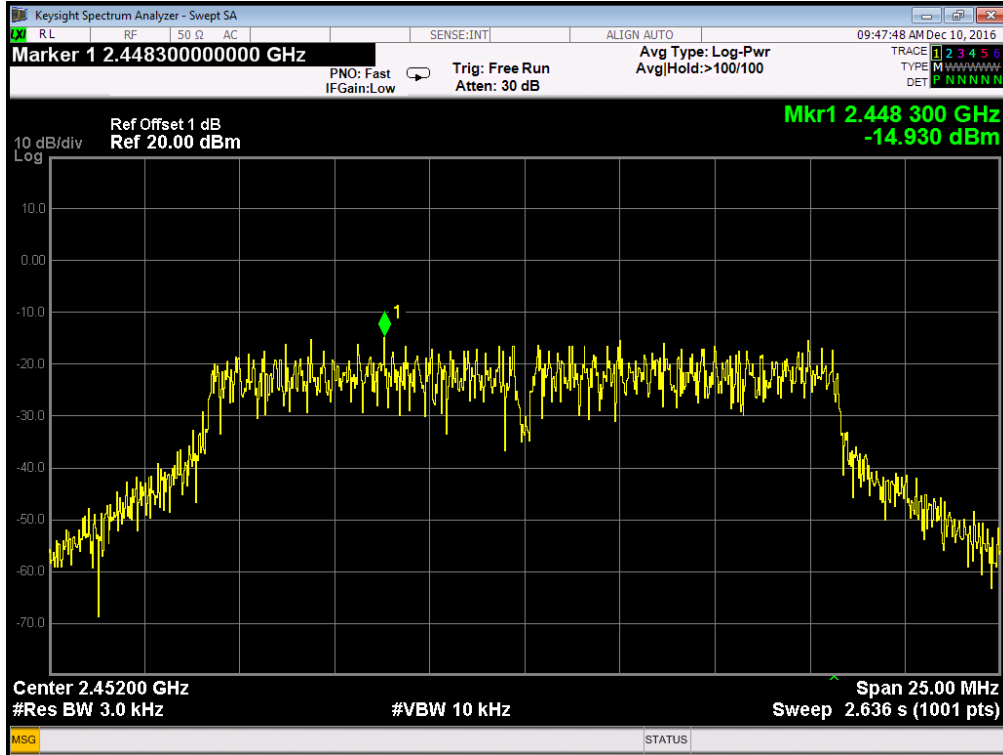

## 6. Spurious Emissions

### 6.1. Test equipment

Item	Equipment	Manufacturer	Model No.	Serial No.	Calibrated until	Calibrated Date
1	EMI Test Receiver	R&S	ESCI	101307	2016/12/19	2015/12/20
2	Spectrum analyzer	Agilent	E4407B	US40240708	2016/12/19	2015/12/20
3	Loop antenna	Chase	HLA6120	20129	2017/07/08	2016/07/09
4	Trilog Broadband Antenna	Schwarzbeck	VULB9163	9163-462	2016/12/19	2015/12/20
5	Double Ridged Horn Antenna	Schwarzbeck	BBHA9120D	9120D 1065	2016/12/19	2015/12/20
6	Pre-Amplifier	R&S	SCU-01	10049	2016/12/19	2015/12/20
7	Pre-Amplifier	A.H.	PAM0-0118	360	2016/12/19	2015/12/20
8	Pre-Amplifier	HP	8449B	3274A06298	2016/12/19	2015/12/20
9	RF Cable	R&S	R01	10403	2016/12/19	2015/12/20
10	RF Cable	R&S	R02	10512	2016/12/19	2015/12/20
11	Horn Antenna	Schwarzbeck	BBHA 9170	9170 1248	2016/12/19	2015/12/20

### 6.2. Block diagram of test setup

In 3m Anechoic Chamber Test Setup Diagram for below 1GHz

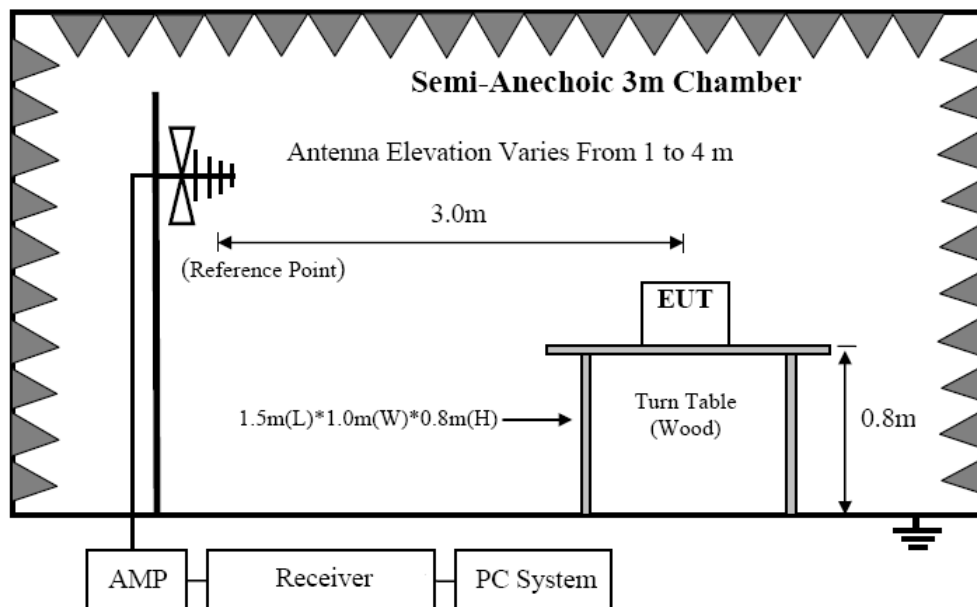

In 3m Anechoic Chamber Test Setup Diagram for frequency above 1GHz

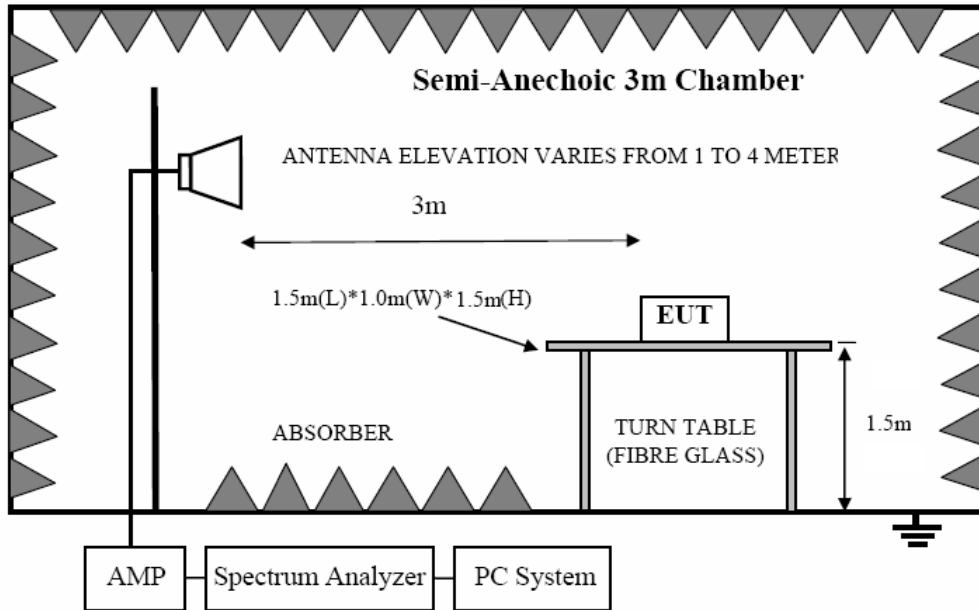

Note: For harmonic emissions test a appropriate high pass filter was inserted in the input port of AMP.

### 6.3. Limit

#### 6.3.1 FCC 15.205 Restricted frequency band

MHz	MHz	MHz	GHz
0.090 - 0.110	16.42 - 16.423	399.9 - 410	4.5 - 5.15
<sup>1</sup> 0.495 - 0.505	16.69475 - 16.69525	608 - 614	5.35 - 5.46
2.1735 - 2.1905	16.80425 - 16.80475	960 - 1240	7.25 - 7.75
4.125 - 4.128	25.5 - 25.67	1300 - 1427	8.025 - 8.5
4.17725 - 4.17775	37.5 - 38.25	1435 - 1626.5	9.0 - 9.2
4.20725 - 4.20775	73 - 74.6	1645.5 - 1646.5	9.3 - 9.5
6.215 - 6.218	74.8 - 75.2	1660 - 1710	10.6 - 12.7
6.26775 - 6.26825	108 - 121.94	1718.8 - 1722.2	13.25 - 13.4
6.31175 - 6.31225	123 - 138	2200 - 2300	14.47 - 14.5
8.291 - 8.294	149.9 - 150.05	2310 - 2390	15.35 - 16.2
8.362 - 8.366	156.52475 - 156.52525	2483.5 - 2500	17.7 - 21.4
8.37625 - 8.38675	156.7 - 156.9	2690 - 2900	22.01 - 23.12
8.41425 - 8.41475	162.0125 - 167.17	3260 - 3267	23.6 - 24.0
12.29 - 12.293	167.72 - 173.2	3332 - 3339	31.2 - 31.8
12.51975 - 12.52025	240 - 285	3345.8 - 3358	36.43 - 36.5
12.57675 - 12.57725	322 - 335.4	3600 - 4400	( <sup>2</sup> )

## 6.3.2 FCC 15.209 Limit

FREQUENCY MHz	DISTANCE Meters	FIELD STRENGTHS LIMIT	
		$\mu\text{V}/\text{m}$	$\text{dB}(\mu\text{V})/\text{m}$
30 ~ 88	3	100	40.0
88 ~ 216	3	150	43.5
216 ~ 960	3	200	46.0
960 ~ 1000	3	500	54.0
Above 1000	3	74.0 $\text{dB}(\mu\text{V})/\text{m}$ (Peak) 54.0 $\text{dB}(\mu\text{V})/\text{m}$ (Average)	

## 6.3.3 Limit for this EUT

The radiated emission tests were performed in the 3 meters test site, using the setup accordance with the ANSI C63.10:2013. The specification used was the FCC 15.209, and FCC 15.247 limits.



#### **6.4. TEST PROCEDURE**

- (1) EUT was placed on a non-metallic table, 80 cm above the ground plane inside a semi-anechoic chamber.
- (2) Setup EUT and assistant system according clause 2.4 and 8.2
- (3) Test antenna was located 3m from the EUT on an adjustable mast. Below pre-scan procedure was first performed in order to find prominent radiated emissions.
  - (a) Change work frequency or channel of device if practicable.
  - (b) Change modulation type of device if practicable.
  - (c) Change power supply range from 85% to 115% of the rated supply voltage
  - (d) Rotated EUT though three orthogonal axes to determine the attitude of EUT arrangement produces highest emissions
- (4) Spectrum frequency from 9MHz to 25GHz (tenth harmonic of fundamental frequency) was investigated, and no any obvious emission were detected from 9KHz to 30MHz and 18GHz to 25GHz, so below final test was performed with frequency range from 30MHz to 18GHz.
- (5) For final emissions measurements at each frequency of interest, the EUT were rotated and the antenna height was varied between 1m and 4m in order to maximize the emission. Measurements in both horizontal and vertical polarities were made and the data was recorded. In order to find the maximum emission, the relative positions of equipments and all of the interface cables were changed according to ANSI C63.10 2013 on Radiated Emission test.
- (6) For emissions from 30MHz to 1GHz, Quasi-Peak values were measured with EMI Receiver and the bandwidth of Receiver is 120 KHz.
- (7) For emissions above 1GHz, both Peak and Average level were measured with Spectrum Analyzer, and the RBW is set at 1MHz, VBW is set at 3MHz for Peak measure, Detector is at PK; RBW is set at 1MHz, VBW is set at 3MHz for Average measure, Detector is at RMS..

## 6.5. TEST RESULT

### Below 30M

<b>EUT:</b>	MASS EFFECT ANDROMEDA CE: NOMAD REMOTE CONTROL	<b>Model No.:</b>	878-004
<b>Temperature:</b>	24°C	<b>Relative Humidity:</b>	55%
<b>Distance:</b>	3m	<b>Test Power:</b>	7.4 Vdc
<b>Polarization:</b>	--	<b>Test Result:</b>	Pass
<b>Test Mode:</b>	TX IEEE 802.11g Mdoe: 2452MHz	<b>Test By:</b>	Lake

Freq. (MHz)	Reading (dBuV/m)	Limit (dBuV/m)	Margin (dB)	State P/F
--	--	--	--	P
--	--	--	--	P

**Note:**

The amplitude of spurious emissions which are attenuated by more than 20dB below the permissible value has no need to be reported.

Distance extrapolation factor =  $20 \log(\text{specific distance}/\text{test distance})(\text{dB})$ ;

Limit line = specific limits(dBuv) + distance extrapolation factor

## Between 30M – 1000 MHz

<b>EUT:</b>	MASS EFFECT ANDROMEDA CE: NOMAD REMOTE CONTROL	<b>Model No.:</b>	878-004
<b>Temperature:</b>	24	<b>Relative Humidity:</b>	55%
<b>Distance:</b>	3m	<b>Test Power:</b>	7.4 Vdc
<b>Polarization:</b>	Vertical	<b>Test Result:</b>	Pass
<b>Standard:</b>	(RE)FCC PART 15 class B 3m	<b>Test By:</b>	Lake
<b>Test Mode:</b>	TX IEEE 802.11g Mdoe: 2452MHz		

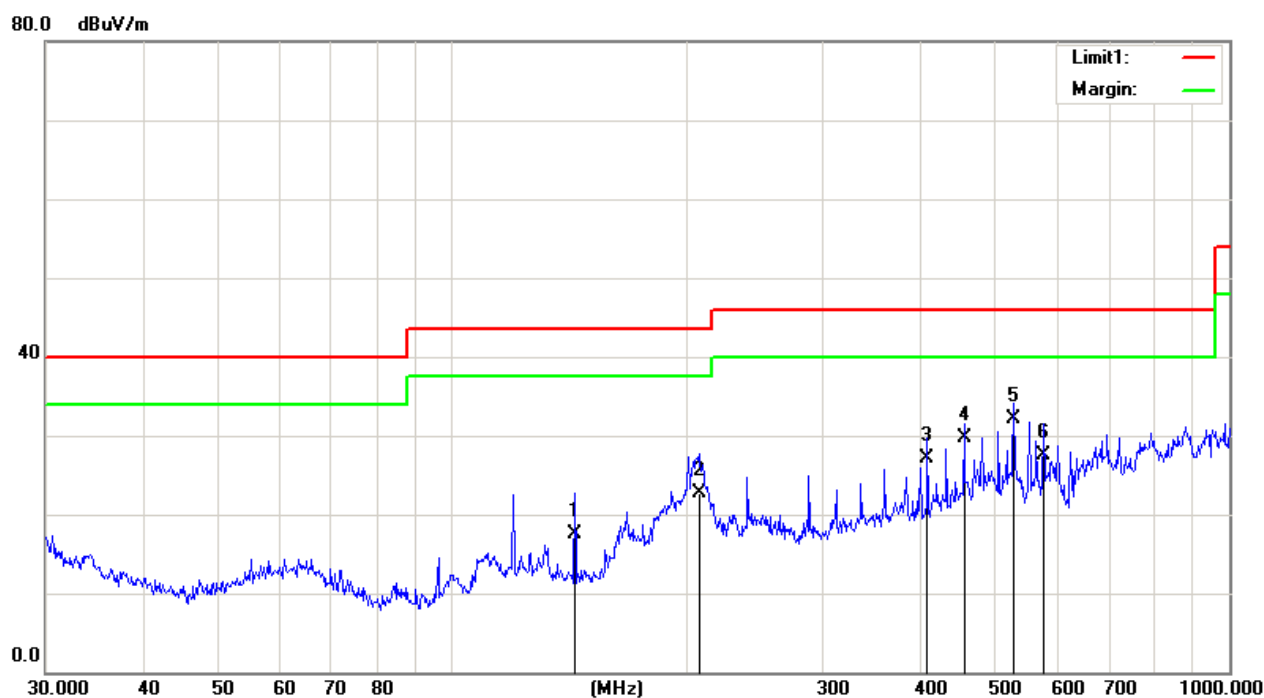

No.	Frequency (MHz)	Reading (dBuV/m)	Correct Factor(dB/m)	Result (dBuV/m)	Limit (dBuV/m)	Margin (dB)	Remark
1	143.8294	31.36	-13.91	17.45	43.50	-26.05	QP
2	207.8501	31.22	-8.53	22.69	43.50	-20.81	QP
3	408.9460	32.59	-5.45	27.14	46.00	-18.86	QP
4	455.9058	31.97	-2.34	29.63	46.00	-16.37	QP
5	528.2458	32.81	-0.70	32.11	46.00	-13.89	QP
6	576.6443	29.92	-2.36	27.56	46.00	-18.44	QP

<b>EUT:</b>	MASS EFFECT ANDROMEDA CE: NOMAD REMOTE CONTROL	<b>Model No.:</b>	878-004
<b>Temperature:</b>	24	<b>Relative Humidity:</b>	55%
<b>Distance:</b>	3m	<b>Test Power:</b>	7.4 Vdc
<b>Polarization:</b>	Horizontal	<b>Test Result:</b>	Pass
<b>Standard:</b>	(RE)FCC PART 15 class B 3m	<b>Test By:</b>	Lake
<b>Test Mode:</b>	TX IEEE 802.11g Mdoe: 2452MHz		

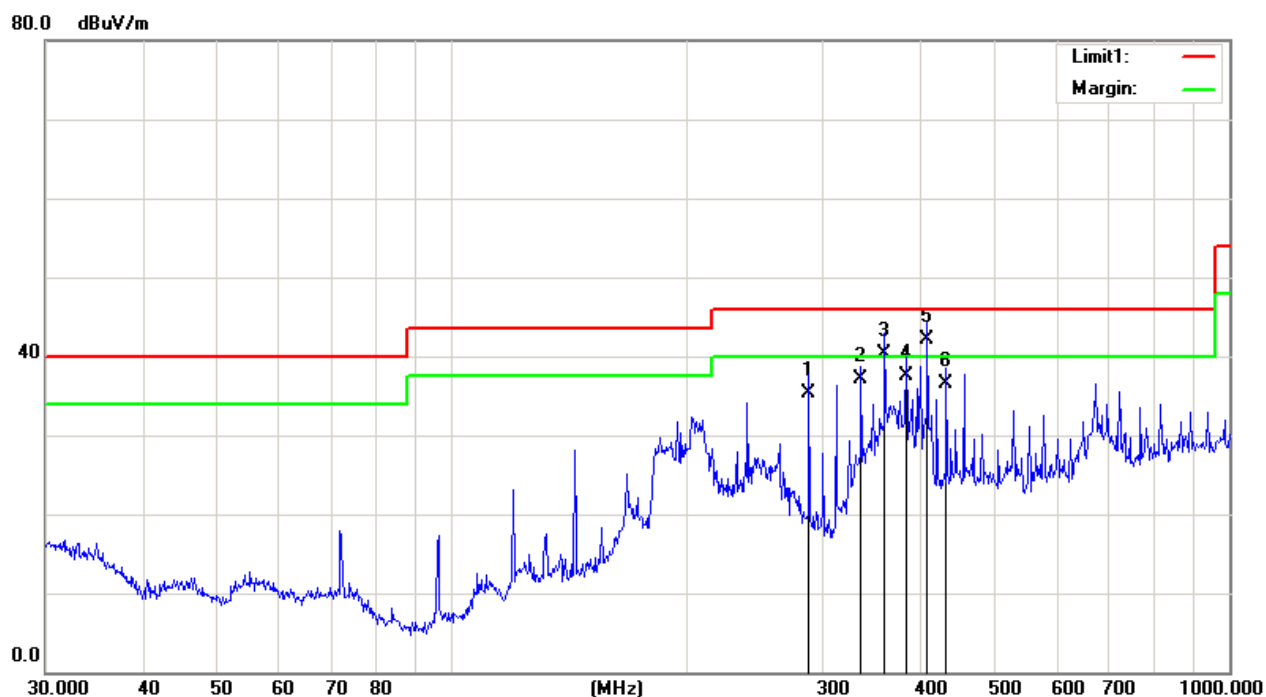

No.	Frequency (MHz)	Reading (dBuV/m)	Correct Factor(dB/m)	Result (dBuV/m)	Limit (dBuV/m)	Margin (dB)	Remark
1	287.9904	42.95	-7.69	35.26	46.00	-10.74	QP
2	336.0351	42.83	-5.82	37.01	46.00	-8.99	QP
3	360.4476	46.54	-6.25	40.29	46.00	-5.71	QP
4	383.9318	43.42	-5.90	37.52	46.00	-8.48	QP
5	408.9460	46.72	-4.66	42.06	46.00	-3.94	QP
6	432.5457	39.47	-2.89	36.58	46.00	-9.42	QP

**Between 1000M – 25000 MHz**

<b>Test Site</b>	: 3m Chamber		
<b>EUT</b>	: MASS EFFECT ANDROMEDA : CE: NOMAD REMOTE : CONTROL	<b>Tested By</b>	: Lake
<b>Power Supply</b>	: 7.4 Vdc	<b>Model Number</b>	: 878-004
<b>Condition</b>	: Temp:24.5'C,Humi:55%, : Press:100.1kPa	<b>Test Mode</b>	: Tx mode
<b>Memo</b>	: TX IEEE 802.11g Mdoe: : 2452MHz	<b>Antenna/Distance</b>	: VULB 9163 /3m

Frequency (MHz)	Receiver		Rx Antenna		Cable loss (dB)	Amplifier Gain (dB)	Corrected Amplitude (dB $\mu$ V/m)	FCC 15.247	
	Reading (dB $\mu$ V)	Detector (PK/QP/AV)	Polar (H/V)	Factor (dB)				Limit (dB $\mu$ V/m)	Margin (dB)
2452MHz									
4904	59.67	PK	H	31.6	1.13	31.66	60.74	74	-13.26
4904	41.62	AV	H	31.6	1.13	31.66	42.69	54	-11.31
4904	54.21	PK	V	31.6	1.13	31.66	55.28	74	-18.72
4904	34.22	AV	V	31.6	1.13	31.66	35.29	54	-18.71
7356	48.43	PK	H	36.8	1.38	31.65	54.96	74	-19.04
7356	30.49	AV	H	36.8	1.38	31.65	37.02	54	-16.98
7356	39.03	PK	V	36.8	1.38	31.65	45.56	74	-28.44
7356	26.76	AV	V	36.8	1.38	31.65	33.29	54	-20.71
9808	39.3	PK	H	40.3	1.62	31.64	49.58	74	-24.42
9808	23.56	AV	H	40.3	1.62	31.64	33.84	54	-20.16
9808	32.84	PK	V	40.3	1.62	31.64	43.12	74	-30.88
9808	21.14	AV	V	40.3	1.62	31.64	31.42	54	-22.58

Note: 1. Result Level = Read Level + Antenna Factor + Cable loss

**Radiated band edge:**

Frequency (MHz)	Receiver		Rx Antenna		Cable loss (dB)	Amplifier Gain (dB)	Corrected Amplitude (dBμV/m)	FCC 15.247	
	Reading (dBμV)	PK/QP/AV	Polar (H/V)	Factor (dB)				Limit (dBμV/m)	Margin (dB)
802.11g Mode 2452MHz									
2390	26.26	PK	H	27.6	0.85	0	54.71	74	-19.29
2390	13.32	AV	H	27.6	0.85	0	41.77	54	-12.23
2390	25.39	PK	V	27.6	0.85	0	53.84	74	-20.16
2390	13.33	AV	V	27.6	0.85	0	41.78	54	-12.22
2400	25.81	PK	H	27.7	0.86	0	54.37	74	-19.63
2400	13.26	AV	H	27.7	0.86	0	41.82	54	-12.18
2400	24.77	PK	V	27.7	0.86	0	53.33	74	-20.67
2400	13.24	AV	V	27.7	0.86	0	41.8	54	-12.20
2483.5	26.09	PK	H	27.9	0.87	0	54.86	74	-19.14
2483.5	13.09	AV	H	27.9	0.87	0	41.86	54	-12.14
2483.5	24.87	PK	V	27.9	0.87	0	53.64	74	-20.36
2483.5	13.09	AV	V	27.9	0.87	0	41.86	54	-12.14

Note: 1. Result Level = Read Level + Antenna Factor + Cable Loss- Amplifier Gain

## 7. 100 kHz Bandwidth of Frequency Band Edge

### 7.1. Test equipment

Item	Equipment	Manufacturer	Model No.	Serial No.	Calibrated until	Calibrated Date
1	Spectrum analyzer	KEYSIGHT	N9010A	MY55150427	2017/05/05	2016/05/06
2	Attenuator	Mini-Circuits	BW-S10W2	101109	2016/12/19	2015/12/20
3	RF Cable	Micable	C10-01-01-1	100309	2016/12/19	2015/12/20

### 7.2. Block diagram of test setup

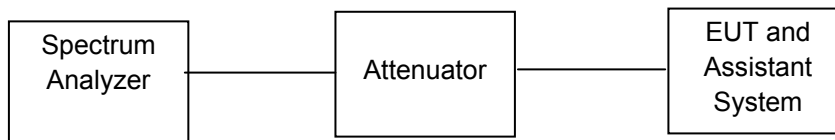

### 7.3. Limit

In any 100 kHz bandwidth outside the frequency band in which the spread spectrum or digitally modulated intentional radiator is operating, the radio frequency power that is produced by the intentional radiator shall be at least 20 dB below that in the 100 kHz bandwidth within the band that contains the highest level of the desired power, based on either an RF conducted or a radiated measurement, provided the transmitter demonstrates compliance with the peak conducted power limits. If the transmitter complies with the conducted power limits based on the use of RMS averaging over a time interval, as permitted under paragraph (b)(3) of this section, the attenuation required under this paragraph shall be 30 dB instead of 20 dB. Attenuation below the general limits specified in §15.209(a) is not required. In addition, radiated emissions which fall in the restricted bands, as defined in §15.205(a), must also comply with the radiated emission limits specified in §15.209(a) (see §15.205(c)).

### 7.4. Test Procedure

1. Check the calibration of the measuring instrument using either an internal calibrator or a known signal from an external generator.
2. Remove the antenna from the EUT and then connect to a low loss RF cable from the antenna port to a EMI test receiver, then turn on the EUT and make it operate in transmitting mode. Then set it to Low Channel and High Channel within its operating range, and make sure the instrument is operated in its linear range.
3. Set both RBW and VBW of spectrum analyzer to 100 kHz with a convenient frequency span including 100 kHz bandwidth from band edge.
4. Measure the highest amplitude appearing on spectral display and set it as a reference level. Plot the graph with marking the highest point and edge frequency.
5. Repeat above procedures until all measured frequencies were complete.

### 7.5. Test result

Frequency Band	Delta Peak to band emission (dBc)	>Limit (dBc)	Result
IEEE 802.11g Mdoe: 2452MHz			
2400	55.57	20	Pass
2483.5	55.77	20	Pass

802.11 g Mode

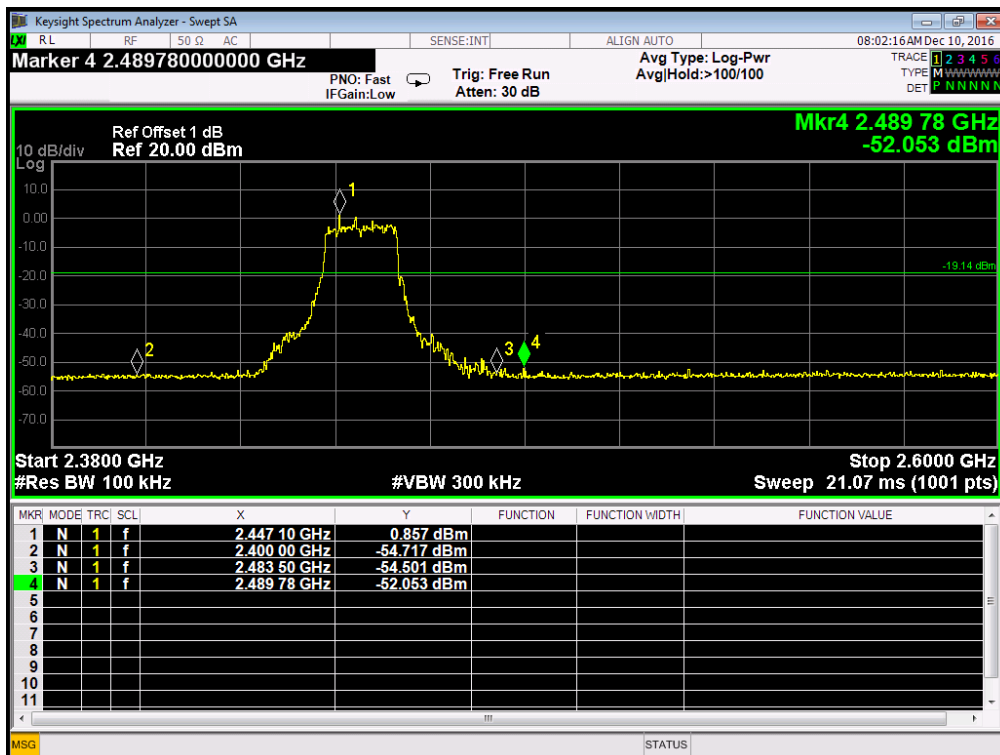



## 8. Conducted Spurious Emissions

### 8.1. Test Equipment

Item	Equipment	Manufacturer	Model No.	Serial No.	Calibrated until	Calibrated Date
1	Spectrum analyzer	KEYSIGHT	N9010A	MY55150427	2017/05/05	2016/05/06
2	Attenuator	Mini-Circuits	BW-S10W2	101109	2016/12/19	2015/12/20
3	RF Cable	Micable	C10-01-01-1	100309	2016/12/19	2015/12/20

### 8.2. Limit

In any 100kHz bandwidth outside the frequency bands in which the spread spectrum intentional radiator is operating, the radio frequency power that is produced by the intentional radiator shall be at least 20dB below that in the 100kHz bandwidth within the band that contains the highest level of the desired power.

### 8.3. Test Procedure

The transmitter output was connected to a spectrum analyzer, The resolution bandwidth is set to 100 kHz, The video bandwidth is set to 300 kHz and measure all the emissions detected.

### 8.4. Test result

PASS (See below detailed test result.)

802.11 g Mode 2452MHz

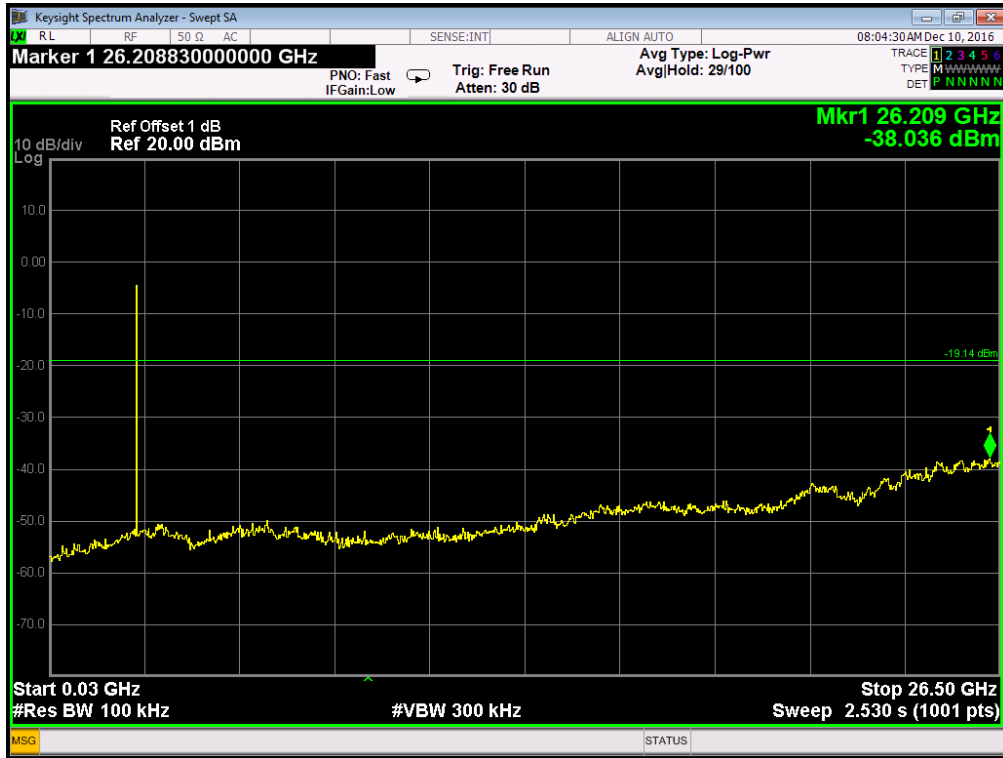

## **9. Antenna Requirements**

### **9.1. Limit**

For intentional device, according to FCC 47 CFR Section 15.203, an intentional radiator shall be designed to ensure that no antenna other than that furnished by the responsible party shall be used with the device. And according to FCC 47 CFR Section 15.247 (b), if transmitting antennas of directional gain greater than 6dBi are used, the power shall be reduced by the amount in dB that the directional gain of the antenna exceeds 6dBi.

### **9.2. Result**

The antennas used for this product are built-in undetachable dipole antenna and that no antenna other than that furnished by the responsible party shall be used with the device, the maximum peak gain of the transmit antenna is only 2.81dBi. The EUT has an internal antenna, the directional gain of antenna is 2.81 dBi, and the antenna connector is designed with permanent attachment and no consideration of replacement. Therefore the EUT is considered sufficient to comply with the provision.

**END OF REPORT**