

FCC CERTIFICATION TEST REPORT

For

FCC ID: X5B-064015R

IC: 8814A-064015R

Report Reference No..... : 15FAB08010 101

FCC 2.948 No..... : 923232

IC site number : 11033A

Date of issue..... : 2015-09-21

Testing Laboratory..... : ATT Product Service Co., Ltd.

Address..... : No. 3, ChangLianShan Industrial Park, ChangAn Town,
DongGuan City, GuangDong, China.

Applicant's name : PERFORMANCE DESIGNED PRODUCTS, LLC

Address..... : 14144 Ventura Blvd, Suite 200 Sherman Oaks, CA 91423
U.S.A

Manufacturer..... : PERFORMANCE DESIGNED PRODUCTS, LLC

Test specification:

Test item description..... : AG WIRELESS CONTROLLER FOR PS3

Trade Mark..... : --

Model/Type reference : 064-015R

Ratings..... : 5Vdc by notebook supply;

Tested by

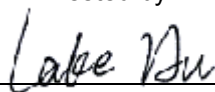

(Lake Hu/Engineer)

Approved by

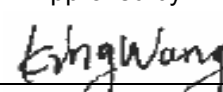

(King Wang/EMC Manger)

TABLE OF CONTENTS

1. Summary of test results	5
2. General test information.....	6
2.1. Description of EUT	6
2.2. Accessories of EUT	6
2.3. Assistant equipment used for test.....	6
2.4. Block diagram of EUT configuration for test.....	7
2.5. Test environment conditions.....	7
2.6. Measurement uncertainty	8
3. 20dB & 99% Bandwidth	9
3.1. Test equipment.....	9
3.2. Block diagram of test setup	9
3.3. Limits	9
3.4. Test Procedure	9
3.5. Test Result	10
3.6. Original test data	10
4. CARRIER FREQUENCY SEPARATION TEST	12
4.1. Test equipment.....	12
4.2. The Requirement For Section 15.247(a)(1)	12
4.3. EUT Configuration on Measurement.....	12
4.4. Operating Condition of EUT	12
4.5. Test Procedure	13
4.6. Test Result	13
5. NUMBER OF HOPPING FREQUENCY TEST	16
5.1. Test equipment.....	16
5.2. The Requirement For Section 15.247(a)(1)(iii).....	16
5.3. EUT Configuration on Measurement.....	16
5.4. Operating Condition of EUT	16
5.5. Test Procedure	16
5.6. Test Result	17
6. DWELL TIME TEST	18
6.1. Test equipment.....	18
6.2. The Requirement For Section 15.247(a)(1)(iii).....	18
6.3. EUT Configuration on Measurement.....	18
6.4. Operating Condition of EUT	18
6.5. Test Procedure	18

6.6.Test Result	19
7. Maxmum Output Power.....	25
7.1.Test equipment.....	25
7.2.Block diagram of test setup	25
7.3.Limits.....	25
7.4.Test Procedure	26
7.5.Test Result	26
8.Spurious Emission.....	29
8.1.Test equipment.....	29
8.2.Block diagram of test setup	29
8.3.Limit.....	31
8.4.Test Procedure	32
8.5.Test result.....	34
9.Band Edge.....	37
9.1.Test equipment.....	37
9.2.Block diagram of test setup	37
9.3.Limit.....	38
9.4.Test Procedure	38
9.5.Test result.....	38
10. Conducted Spurious Emissions.....	39
10.1.Test Equipment	39
10.2.Limit.....	39
10.3.Test Procedure	39
10.4.Test result.....	39
11. Power Line Conducted Emission.....	43
11.1.Test equipment.....	43
11.2.Block diagram of test setup	43
11.3.Power Line Conducted Emission Limits (Class B).....	43
11.5.Test Result.....	45
12.Antenna Requirements.....	47
12.1.Limit.....	47
12.2.Result.....	47

TEST REPORT DECLARE

Applicant	:	PERFORMANCE DESIGNED PRODUCTS, LLC
Address	:	14144 Ventura Blvd, Suite 200 Sherman Oaks, CA 91423 U.S.A
Equipment under Test	:	AG WIRELESS CONTROLLER FOR PS3
Model No	:	064-015R
FCC ID	:	X5B-064015R
Manufacturer	:	PERFORMANCE DESIGNED PRODUCTS, LLC
Address	:	14144 Ventura Blvd, Suite 200 Sherman Oaks, CA 91423 U.S.A

Test Standard Used: FCC Rules and Regulations Part 15 Subpart C: 2013
 RSS-247 ISSUE 1 MAY 2015; RSS-GEN ISSUE 4 NOV 2014

Test procedure used: ANSI C63.4: 2014, DA 00-705.
 ANSI C63.10:2013

We Declare:

The equipment described above is tested by ATT Product Service Co., Ltd and in the configuration tested the equipment complied with the standards specified above. The test results are contained in this test report and ATT Product Service Co., Ltd is assumed of full responsibility for the accuracy and completeness of these tests.

After test and evaluation, our opinion is that the equipment provided for test compliance with the requirement of the above FCC standards.

Report No:	15FAB08010 101		
Date of Test:	2015/08/14-2015/09/21	Date of Report:	2015/09/21

Note: This report applies to above tested sample only. This report shall not be reproduced in parts without written approval of ATT Product Service Co., Ltd.

1. SUMMARY OF TEST RESULTS

The EUT have been tested according to the applicable standards as referenced below.		
Description of Test Item	Standard	Results
20dB Bandwidth & 99% Bandwidth	FCC Part 15: 15.247 RSS-Gen:6.6	PASS
Carrier Frequency Separation Test	FCC Part 15: 15.247 RSS-247:5.1.2	PASS
Number Of Hopping Frequency	FCC Part 15: 15.247 RSS-247:5.1.4	PASS
Dwell Time Test	FCC Part 15: 15.247 RSS-247:5.1.4	PASS
Maximum Output Power	FCC Part 15: 15.247 RSS-247:5.4.2	PASS
Conducted Spurious Emissions	FCC Part 15: 15.247 RSS-247:5.5	PASS
Radiated Spurious Emissions	FCC Part 15:15.205/15.209 RSS-247:3.3	PASS
Antenna requirement	FCC Part 15: 15.203	PASS
Conducted Emission	FCC Part 15:15.207 RSS-Gen:8.8	PASS

2. GENERAL TEST INFORMATION

2.1. DESCRIPTION OF EUT

EUT* Name	: AG WIRELESS CONTROLLER FOR PS3
Model Number	: 064-015R
EUT function description	: Please reference user manual of this device
Power supply	: 5Vdc
Radio Technology	: Bluetooth V1.0
Operation frequency	: 2402-2480MHz
Modulation	: GFSK
Antenna Type	: built-in antenna, maximum PK gain:-0.61dBi
Date of Receipt	: 2015/08/14
Sample Type	: Single production

Note1: EUT is the ab. of equipment under test.

2.2. ACCESSORIES OF EUT

Description of Accessories	Manufacturer	Model number or Type	Output.
/	/	/	/

2.3. ASSISTANT EQUIPMENT USED FOR TEST

Description of Assistant equipment	Manufacturer	Model number or Type	EMC Compliance	SN
Notebook	acer	Aspire E1-472G	/	/

2.4. BLOCK DIAGRAM OF EUT CONFIGURATION FOR TEST

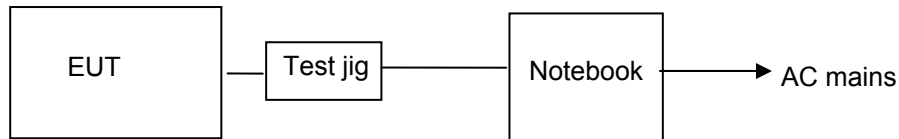

EUT was connected to control to a special test jig provided by manufacturer which has a Micro USB connector to connect to Notebook, and the Notebook will run a special test software to control EUT work in Continuous TX mode, and select test channel, wireless mode and data rate.

Remark: This product only GFSK. The radiation measurements are performed in X, Y, Z axis positioning. And found the X axis positioning which it is worse case, only the test worst case mode is recorded in the report. New battery is used during all test.

2.5. TEST ENVIRONMENT CONDITIONS

During the measurement the environmental conditions were within the listed ranges:

Temperature range:	21-25°C
Humidity range:	40-75%
Pressure range:	86-106kPa

2.6. MEASUREMENT UNCERTAINTY

Test Item	Uncertainty
Uncertainty for Conduction emission test	2.44dB
Uncertainty for Radiation Emission test (9KHz-30MHz)	3.21dB
Uncertainty for Radiation Emission test (30MHz-200MHz)	3.42 dB (Polarize: V)
	3.52 dB (Polarize: H)
Uncertainty for Radiation Emission test (200MHz-1GHz)	3.52 dB (Polarize: V)
	3.54 dB (Polarize: H)
Uncertainty for Radiation Emission test (1GHz to 25GHz)	4.20 dB (Polarize: V)
	4.20 dB (Polarize: H)
Uncertainty for radio frequency	1×10 ⁻⁹
Uncertainty for conducted RF Power	0.65dB

Note: This uncertainty represents an expanded uncertainty expressed at approximately the 95% confidence level using a coverage factor of k=2.

3. 20dB & 99% BANDWIDTH

3.1. TEST EQUIPMENT

Item	Equipment	Manufacturer	Model No.	Serial No.	Cal Due.	Cal. Interval
1	Spectrum analyzer	R&S	FSU	1166.1660.26	2015/12/26	1 Year
2	Attenuator	Mini-Circuits	BW-S10W2	101109	2015/12/26	1 Year
3	RF Cable	Micable	C10-01-01-1	100309	2015/12/26	1 Year

3.2. BLOCK DIAGRAM OF TEST SETUP

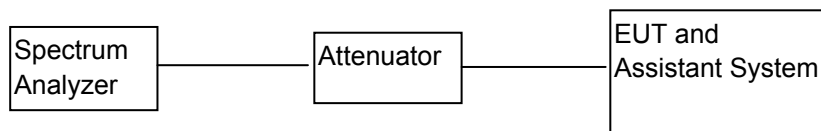

3.3. LIMITS

For direct sequence systems, the minimum 20dB bandwidth shall be at least 25 KHz

3.4. TEST PROCEDURE

- (1) Configure EUT and assistant system according clause 2.4 and 3.2
- (2) Connect EUT's antenna output to spectrum analyzer by RF cable.
- (3) Configure EUT work in test mode as stated in clause 2.4.
- (4) Set the spectrum analyzer as follows:

RBW:	100KHz
VBW:	300KHz
Detector Mode:	Peak
Sweep time:	auto
Trace mode:	Max hold

- (5) Allow the trace to stabilize, measure the maximum width of the emission that is constrained by the frequencies associated with the two outermost amplitude points (upper and lower frequencies) that are attenuated by 20 dB relative to the maximum level measured in the fundamental emission.

3.5. TEST RESULT

Channel	Frequency (MHz)	GFSK 20dB Bandwidth(MHz)	GFSK 99% Bandwidth (MHz)	Result
Low	2402	1.240	1.10	Pass
Middle	2441	1.240	1.10	Pass
High	2480	1.230	1.09	Pass

3.6. ORIGINAL TEST DATA

GFSK

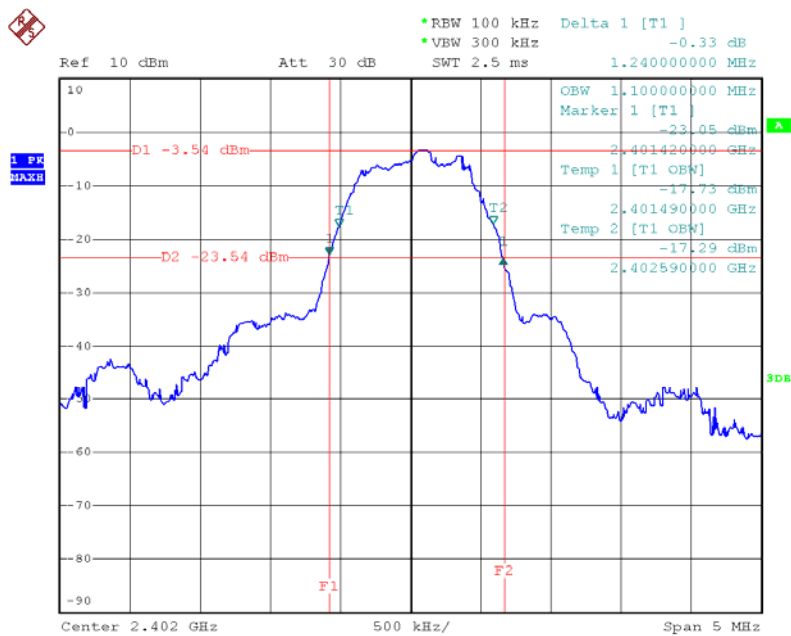

Date: 17.SEP.2015 16:08:37

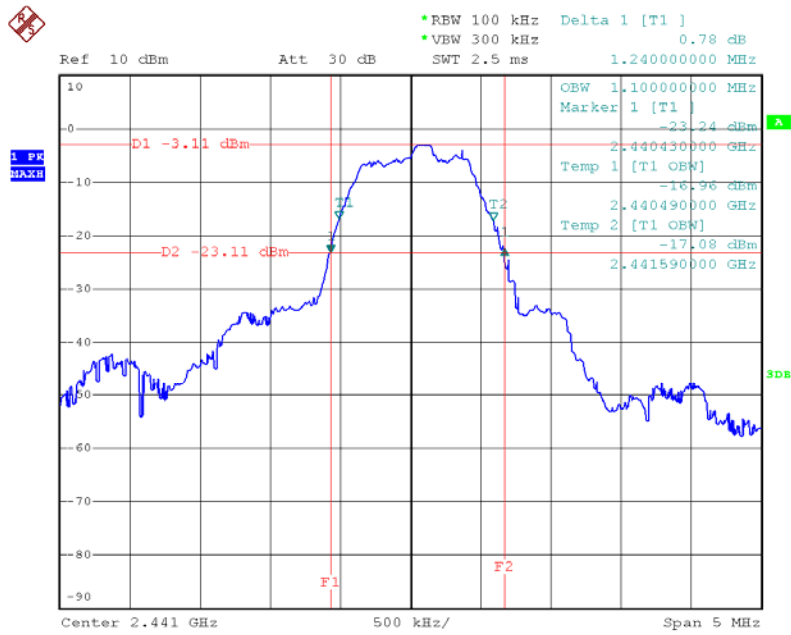

Date: 17.SEP.2015 16:09:27

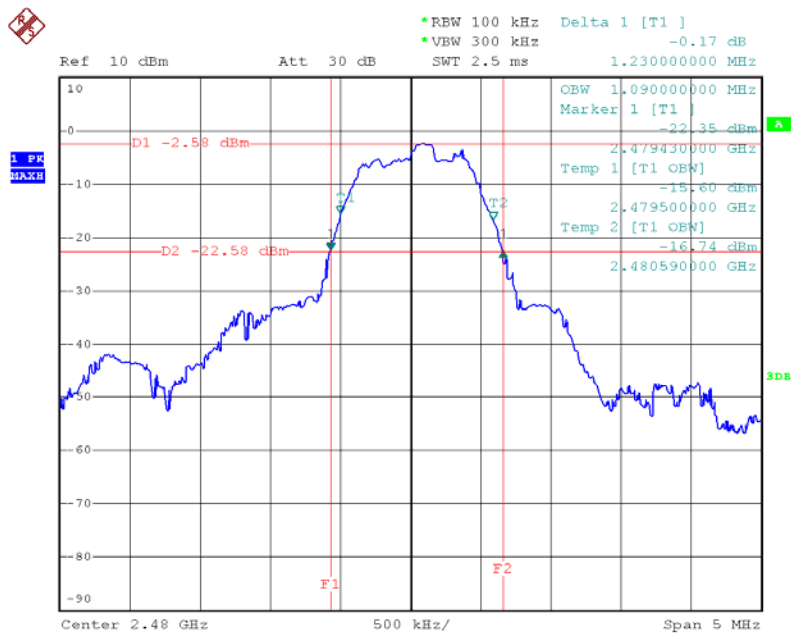

Date: 17.SEP.2015 16:10:12

4. CARRIER FREQUENCY SEPARATION TEST

4.1. TEST EQUIPMENT

Item	Equipment	Manufacturer	Model No.	Serial No.	Cal Due.	Cal. Interval
1	Spectrum analyzer	R&S	FSU	1166.1660.26	2015/12/26	1 Year
2	Attenuator	Mini-Circuits	BW-S10W2	101109	2015/12/26	1 Year
3	RF Cable	Micable	C10-01-01-1	100309	2015/12/26	1 Year

4.2. THE REQUIREMENT FOR SECTION 15.247(A)(1)

Section 15.247(a)(1): Frequency hopping systems shall have hopping channel carrier frequencies separated by a minimum of 25 kHz or the 20 dB bandwidth of the hopping channel, whichever is greater. Alternatively, frequency hopping systems operating in the 2400-2483.5 MHz band may have hopping channel carrier frequencies that are separated by 25 kHz or two-thirds of the 20 dB bandwidth of the hopping channel, whichever is greater, provided the systems operate with an output power no greater than 125 mW. The system shall hop to channel frequencies that are selected at the system hopping rate from a pseudorandomly ordered list of hopping frequencies. Each frequency must be used equally on the average by each transmitter. The system receivers shall have input bandwidths that match the hopping channel bandwidths of their corresponding transmitters and shall shift frequencies in synchronization with the transmitted signals.

4.3. EUT CONFIGURATION ON MEASUREMENT

The equipment are installed on the emission measurement to meet the commission requirements and operating regulations in a manner which tends to maximize its emission characteristics in normal application.

4.4. OPERATING CONDITION OF EUT

- (1) Setup the EUT and simulator as shown as Section 6.1.
- (2) Turn on the power of all equipment.
- (3) Let the EUT work in TX (Hopping on) modes measure it. The transmit frequency are 2402-2480MHz.
We select 2402MHz, 2441MHz, and 2480MHz TX frequency to transmit.

4.5. TEST PROCEDURE

- (1) The transmitter output was connected to the spectrum analyzer through a low loss cable.
- (2) .Set RBW of spectrum analyzer to 100 kHz and VBW to 300 kHz. Adjust Span to 3 MHz.
- (3) Set the adjacent channel of the EUT maxhold another trace.
- (4) Measurement the channel separation

4.6. Test Result

GFSK

Channel	Frequency (MHz)	Channel Separation(MHz)	Limit (MHz)	Result
Low	2402	0.998	>(25KHz or2/3*20dB Bandwidth)	PASS
Middle	2441	1.014	>(25KHz or2/3*20dB Bandwidth)	PASS
High	2479	0.966	>(25KHz or2/3*20dB Bandwidth)	PASS

The spectrum analyzer plots are attached as below.

GFSK

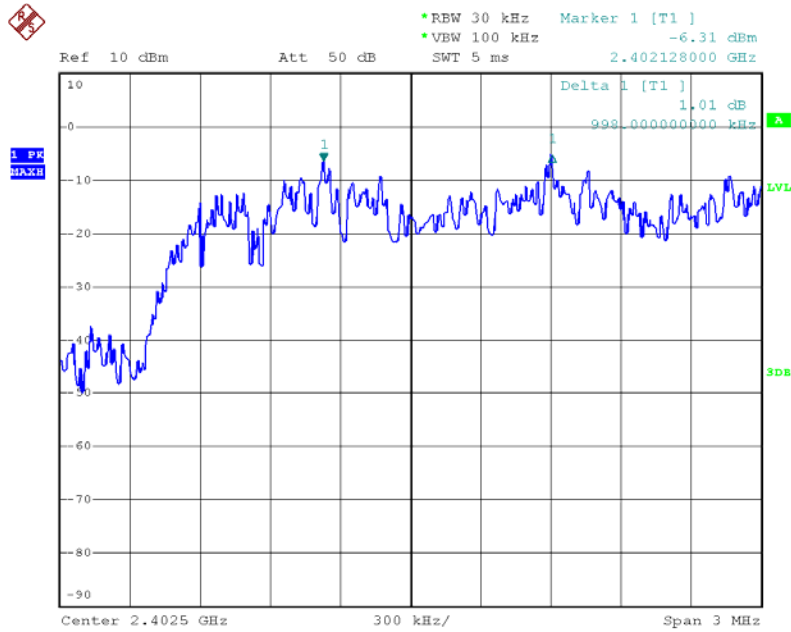

Date: 17.SEP.2015 15:30:33

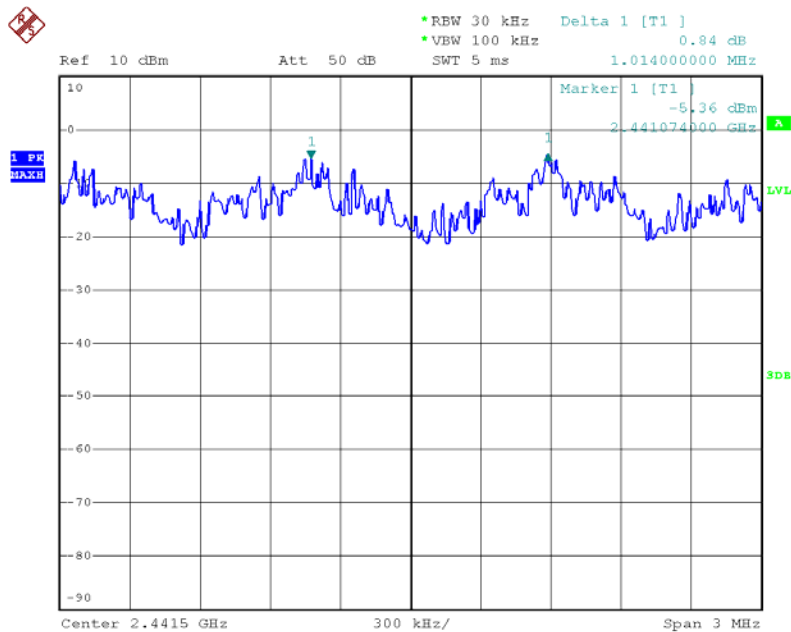

Date: 17.SEP.2015 15:32:49

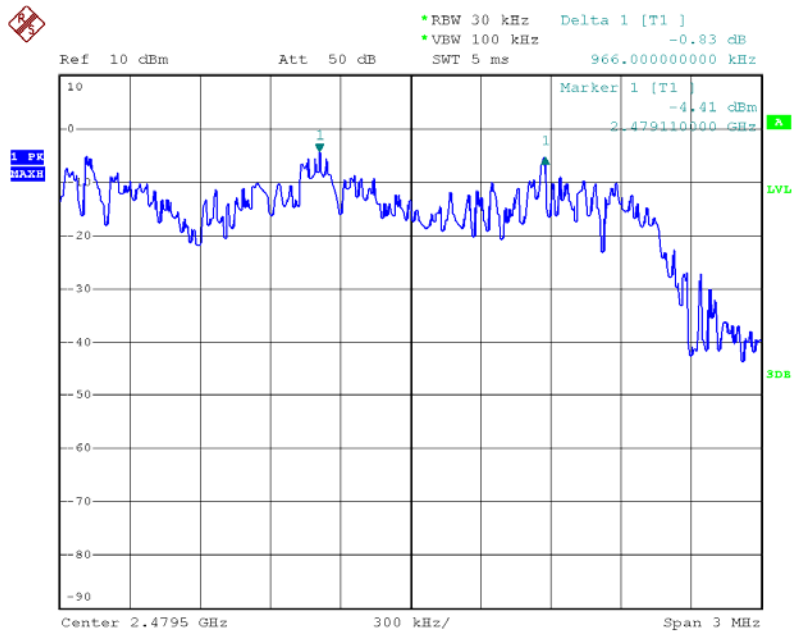

Date: 17.SEP.2015 15:35:56

5. NUMBER OF HOPPING FREQUENCY TEST

5.1. Test equipment

Item	Equipment	Manufacturer	Model No.	Serial No.	Cal Due.	Cal. Interval
1	Spectrum analyzer	R&S	FSU	1166.1660.26	2015/12/26	1 Year
2	Attenuator	Mini-Circuits	BW-S10W2	101109	2015/12/26	1 Year
3	RF Cable	Micable	C10-01-01-1	100309	2015/12/26	1 Year

5.2. THE REQUIREMENT FOR SECTION 15.247(a)(1)(iii)

Section 15.247(a)(1)(iii): Frequency hopping systems in the 2400-2483.5 MHz band shall use at least 15 channels.

5.3. EUT CONFIGURATION ON MEASUREMENT

The equipment are installed on the emission measurement to meet the commission requirements and operating regulations in a manner which tends to maximize its emission characteristics in normal application.

5.4. OPERATING CONDITION OF EUT

- (1) Setup the EUT and simulator as shown as Section 7.1.
- (2) Turn on the power of all equipment.
- (3) Let the EUT work in TX (Hopping on) modes measure it.

5.5. TEST PROCEDURE

- (1) The transmitter output was connected to the spectrum analyzer through a low loss cable.
- (2) Set the spectrum analyzer as Span=83.5MHz, RBW=100 kHz, VBW=300 kHz.
- (3) Max hold, view and count how many channel in the band.

5.6.TEST RESULT

Number of hopping channels

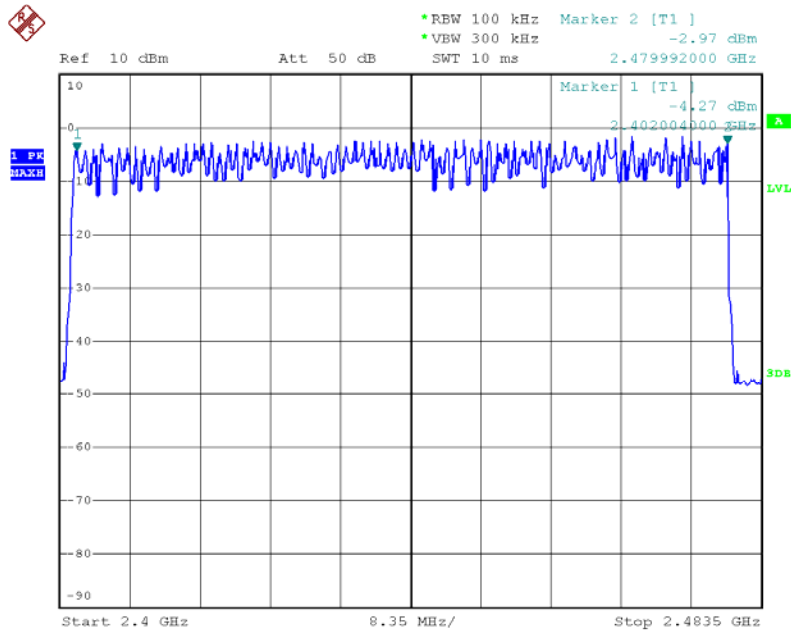

Date: 17.SEP.2015 15:19:56

Channel information									
CH	Frequency	CH	Frequency	CH	Frequency	CH	Frequency	CH	Frequency
0	2402	16	2418	32	2434	48	2450	64	2466
1	2403	17	2419	33	2435	49	2451	65	2467
2	2404	18	2420	34	2436	50	2452	66	2468
3	2405	19	2421	35	2437	51	2453	67	2469
4	2406	20	2422	36	2438	52	2454	68	2470
5	2407	21	2423	37	2439	53	2455	69	2471
6	2408	22	2424	38	2440	54	2456	70	2472
7	2409	23	2425	39	2441	55	2457	71	2473
8	2410	24	2426	40	2442	56	2458	72	2474
9	2411	25	2427	41	2443	57	2459	73	2475
10	2412	26	2428	42	2444	58	2460	74	2476
11	2413	27	2429	43	2445	59	2461	75	2477
12	2414	28	2430	44	2446	60	2462	76	2478
13	2415	29	2431	45	2447	61	2463	77	2479
14	2416	30	2432	46	2448	62	2464	78	2480
15	2417	31	2433	47	2449	63	2465	-	-

6. DWELL TIME TEST

6.1. Test equipment

Item	Equipment	Manufacturer	Model No.	Serial No.	Cal Due.	Cal. Interval
1	Spectrum analyzer	R&S	FSU	1166.1660.26	2015/12/26	1 Year
2	Attenuator	Mini-Circuits	BW-S10W2	101109	2015/12/26	1 Year
3	RF Cable	Micable	C10-01-01-1	100309	2015/12/26	1 Year

6.2. THE REQUIREMENT FOR SECTION 15.247(a)(1)(iii)

Section 15.247(a)(1)(iii): Frequency hopping systems in the 2400-2483.5 MHz band shall use at least 15 channels. The average time of occupancy on any channel shall not be greater than 0.4 seconds within a period of 0.4 seconds multiplied by the number of hopping channels employed. Frequency hopping systems may avoid or suppress transmissions on a particular hopping frequency provided that a minimum of 15 channels are used.

6.3. EUT CONFIGURATION ON MEASUREMENT

The equipment are installed on the emission measurement to meet the commission requirements and operating regulations in a manner which tends to maximize its emission characteristics in normal application.

6.4. OPERATING CONDITION OF EUT

- (1) Setup the EUT and simulator as shown as Section 8.1.
- (2) Turn on the power of all equipment.
- (3) Let the EUT work in TX (Hopping on) modes measure it. The transmit frequency are 2402-2480MHz. We select 2402MHz, 2441MHz, and 2480MHz TX frequency to transmit.

6.5. TEST PROCEDURE

- (1) The transmitter output was connected to the spectrum analyzer through a low loss cable.
- (2) Set center frequency of spectrum analyzer = operating frequency.
- (3) Set the spectrum analyzer as RBW=1MHz, VBW=1MHz, Span=0Hz, Adjust Sweep=5ms, 10ms, 20ms. Get the pulse time.

6.6.TEST RESULT

Mode	Channel Frequency (MHz)	Pulse Time (ms)	Dwell Time (ms)	Limit (ms)
DH1	2402	0.42	134.4	400
	2441	0.42	134.4	400
	2480	0.42	134.4	400
A period transmit time = $0.4 \times 79 = 31.6$ Dwell time = pulse time $\times (1600/(2*79)) \times 31.6$				
DH3	2402	1.74	278.4	400
	2441	1.76	281.6	400
	2480	1.68	268.8	400
A period transmit time = $0.4 \times 79 = 31.6$ Dwell time = pulse time $\times (1600/(4*79)) \times 31.6$				
DH5	2402	3.08	328.5	400
	2441	3.12	332.8	400
	2480	3.04	324.3	400
A period transmit time = $0.4 \times 79 = 31.6$ Dwell time = pulse time $\times (1600/(6*79)) \times 31.6$				

The spectrum analyzer plots are attached as below:

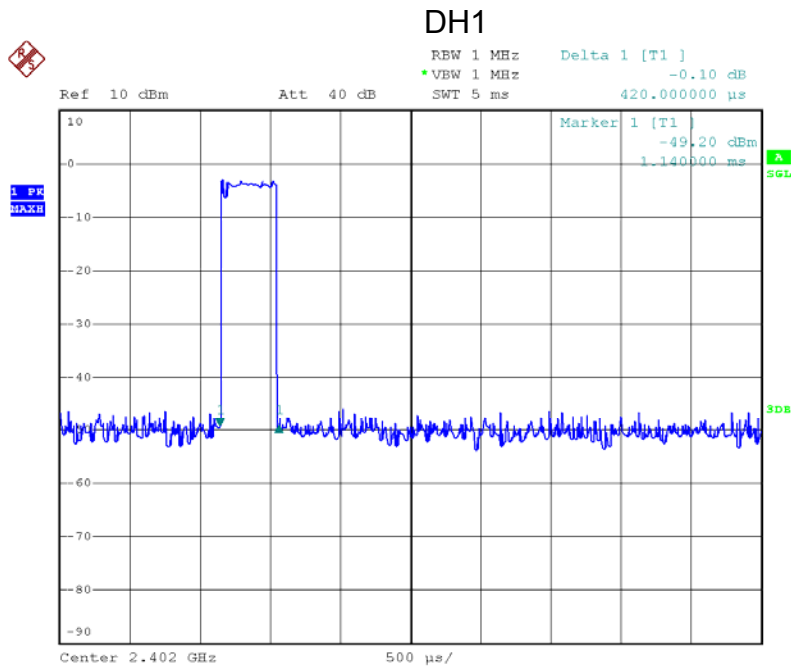

Date: 17.SEP.2015 15:58:19

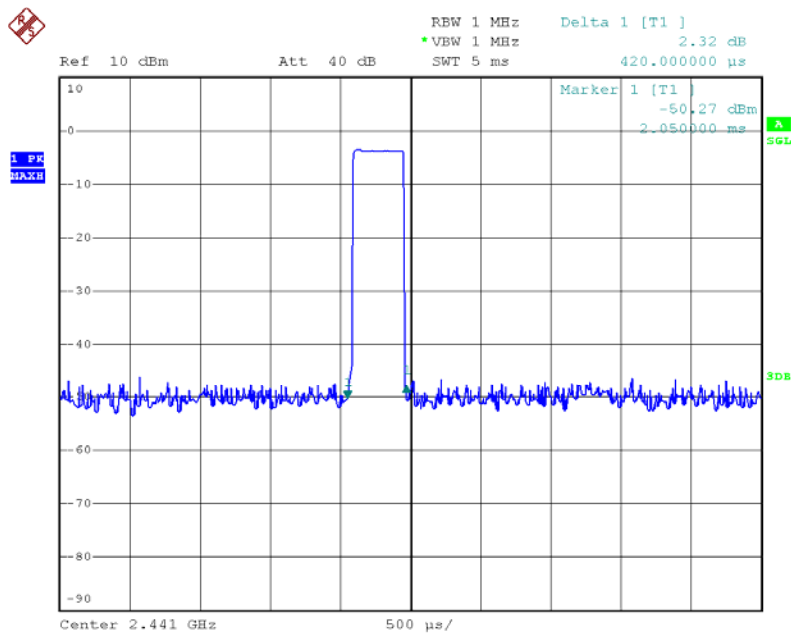

Date: 17.SEP.2015 15:59:16

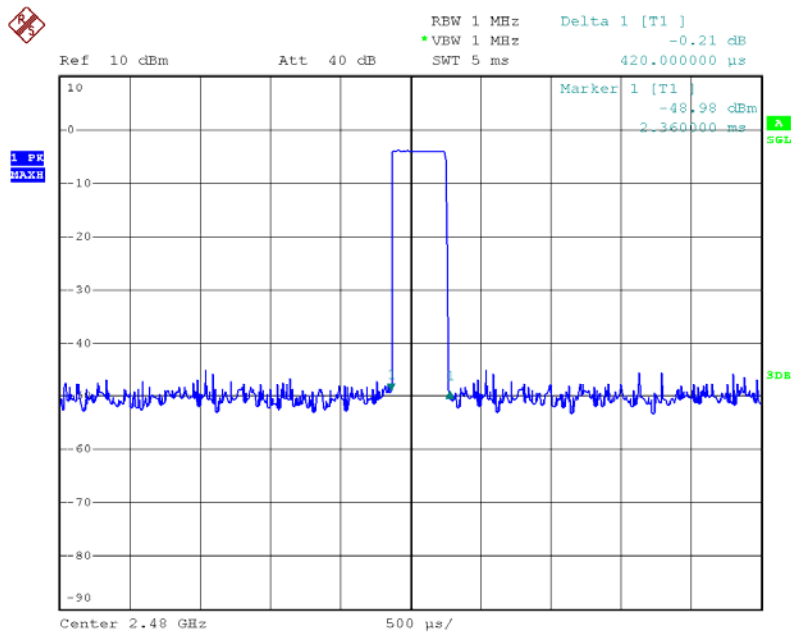

Date: 17.SEP.2015 16:00:24

DH3

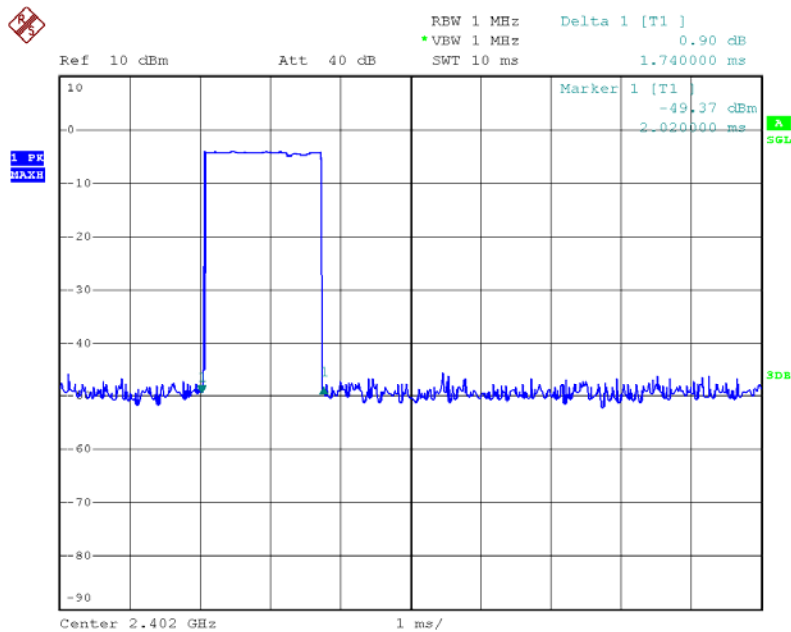

Date: 17.SEP.2015 16:01:09

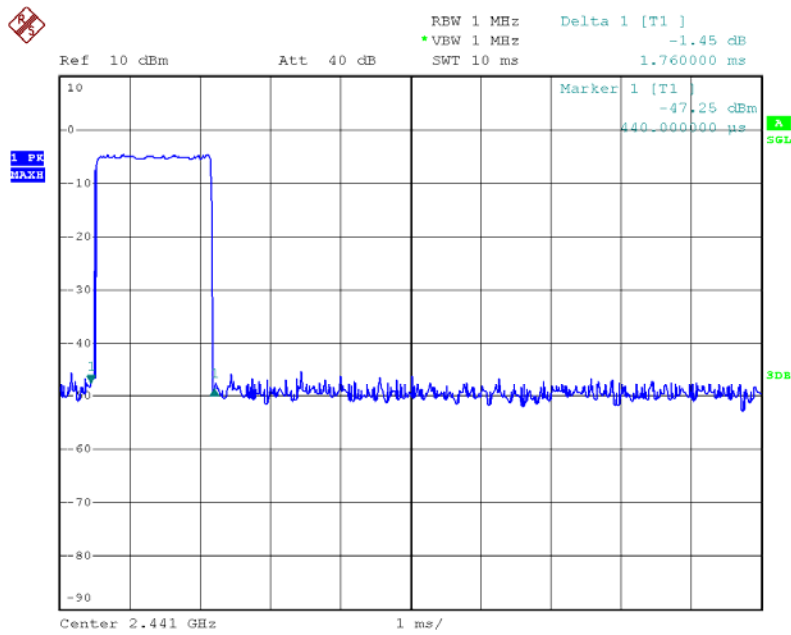

Date: 17.SEP.2015 16:01:34

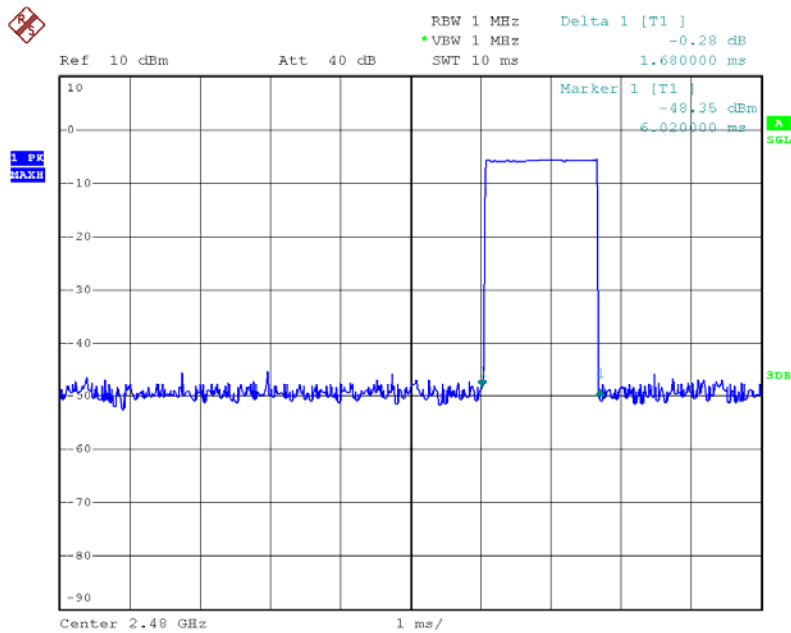

Date: 17.SEP.2015 16:01:58

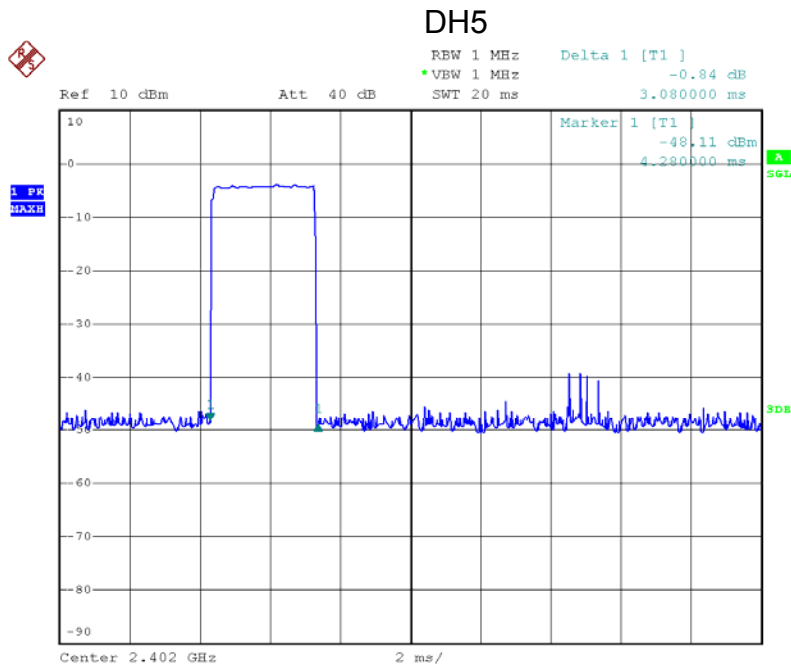

Date: 17.SEP.2015 16:03:00

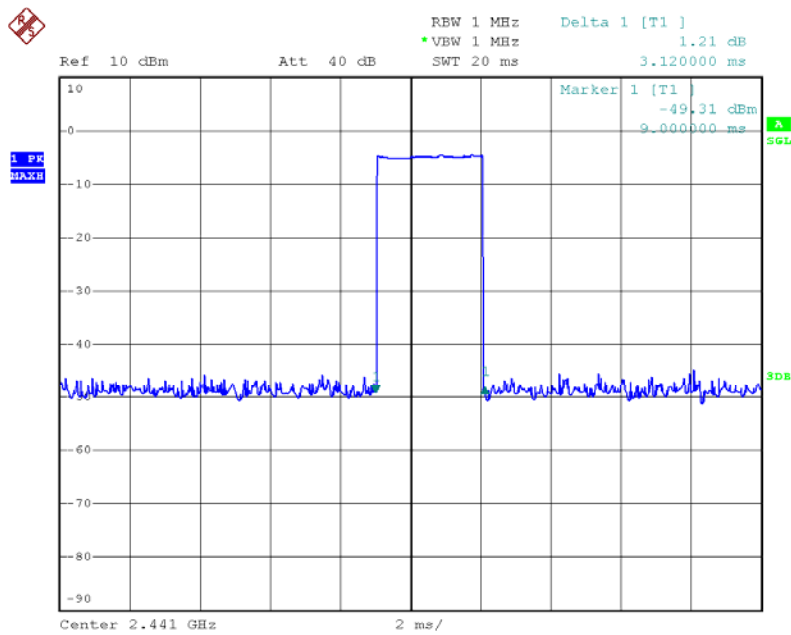

Date: 17.SEP.2015 16:03:24

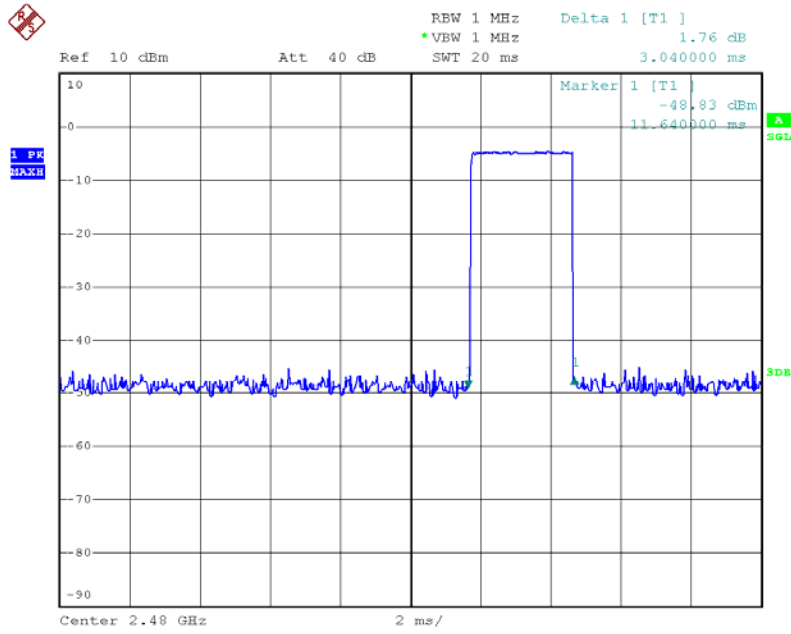

Date: 17.SEP.2015 16:03:48

7. MAXMUM OUTPUT POWER

7.1.TEST EQUIPMENT

Same with 3.1

7.2.BLOCK DIAGRAM OF TEST SETUP

Same with 3.2

7.3.LIMITS

For systems using digital modulation in the 902-928 MHz, 2400-2483.5 MHz bands: 0.125 Watt. If transmitting antennas of directional gain greater than 6 dBi are used, the conducted output power from the intentional radiator shall be reduced below the stated values as appropriate, by the amount in dB that the directional gain of the antenna exceeds 6 dBi.

7.4.TEST PROCEDURE

- (1) Configure EUT and assistant system according clause 2.4 and 3.2
- (2) Connect EUT's antenna output to spectrum analyzer by RF cable.
- (3) Configure EUT work in test mode as stated in clause 2.4.
- (4) Set the spectrum analyzer as follows:

RBW:	3MHz
VBW:	10MHz
Span	>1.5x 20dB bandwidth
Detector Mode:	Peak
Sweep time:	auto
Trace mode	Max hold

7.5.TEST RESULT

EUT Set Mode	Data Rate (Mbps)	Frequency (MHz)	Result(dBm)
			Peak
Tx mode (worst case:GFSK)	1	2402	-3.25
		2441	-2.77
		2480	-2.28
Limit: 21dBm		Conclusion: PASS	

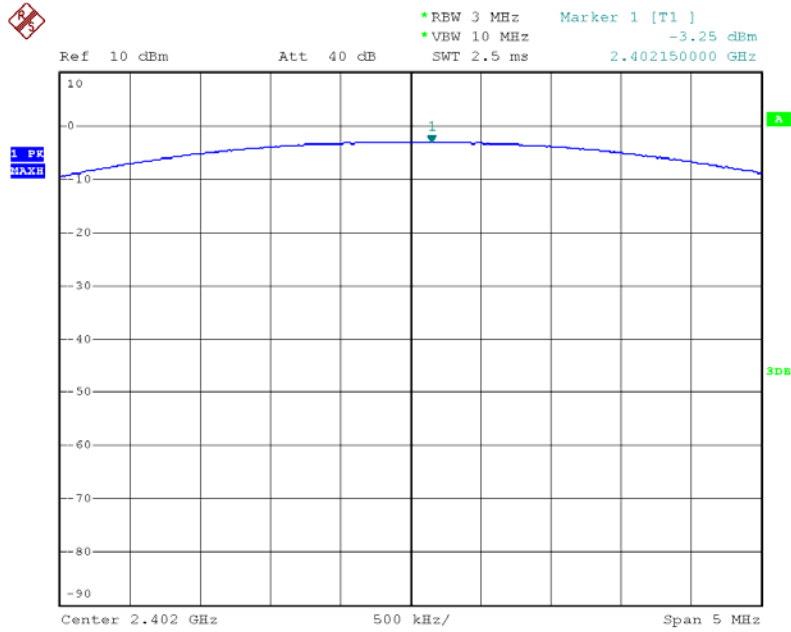

Date: 17.SEP.2015 16:11:07

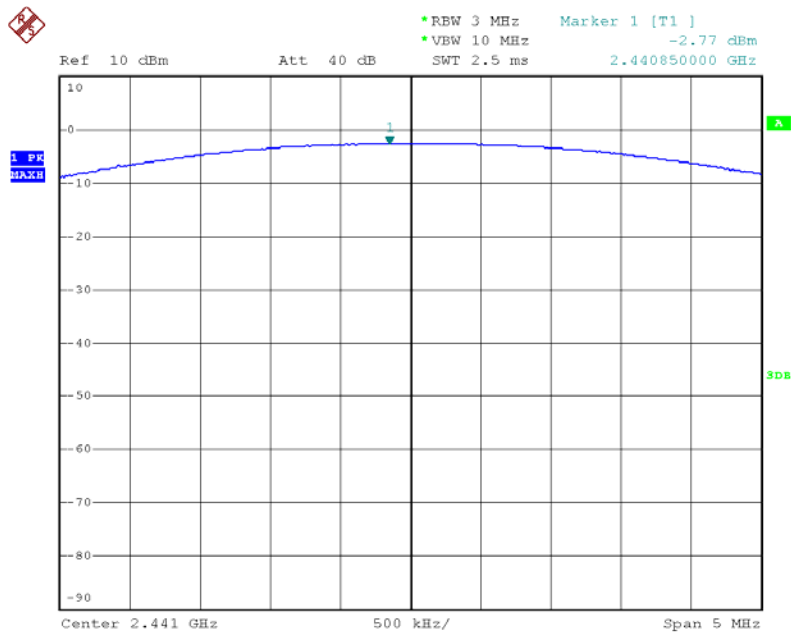

Date: 17.SEP.2015 16:11:31

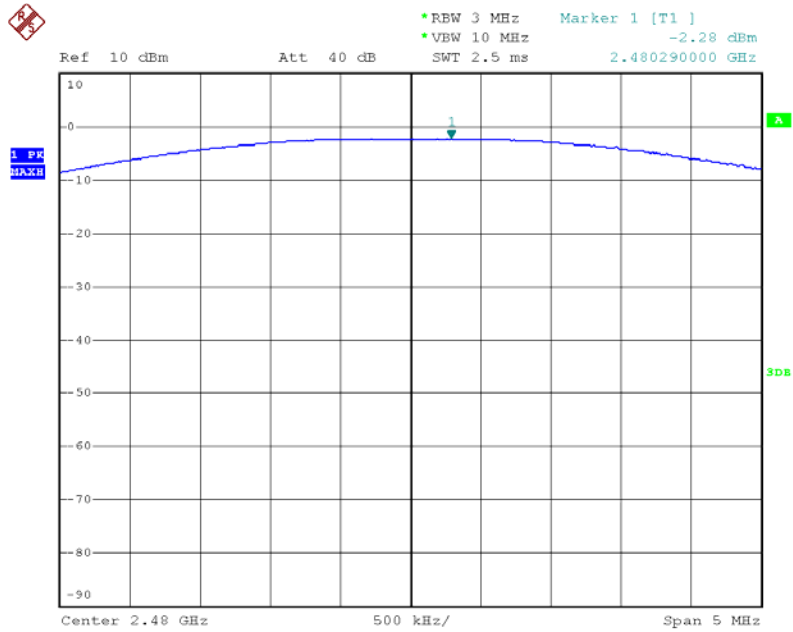

Date: 17.SEP.2015 16:11:40

8.SPURIOUS EMISSION

8.1. TEST EQUIPMENT

Item	Equipment	Manufacturer	Model No.	Serial No.	Cal Due.	Cal. Interval
1	EMI Test Receiver	R&S	ESU8	100316	2015/12/26	1 Year
2	Spectrum analyzer	R&S	FSU	1166.1660.26	2016/07/11	1 Year
3	Loop antenna	TESEQ	HLA6120	20129	2015/12/26	1 Year
4	Trilog Broadband Antenna	Schwarzbeck	VULB9163	9163-462	2015/12/26	1 Year
5	Double Ridged Horn Antenna	R&S	HF907	100276	2015/12/26	1 Year
6	Horn Antenna	EMCO	3116	00060095	2015/12/26	1 Year
7	Pre-amplifier	A.H.	PAM-1840VH	562	2015/12/26	1 Year
8	Pre-amplifier	R&S	AFS33-18002 650-30-8P-44	SEL0080	2015/12/26	1 Year
9	RF Cable	R&S	R01	10403	2015/12/26	1 Year
10	RF Cable	R&S	R02	10512	2015/12/26	1 Year

8.2. BLOCK DIAGRAM OF TEST SETUP

In 3m Anechoic Chamber Test Setup Diagram for 9KHz-30MHz

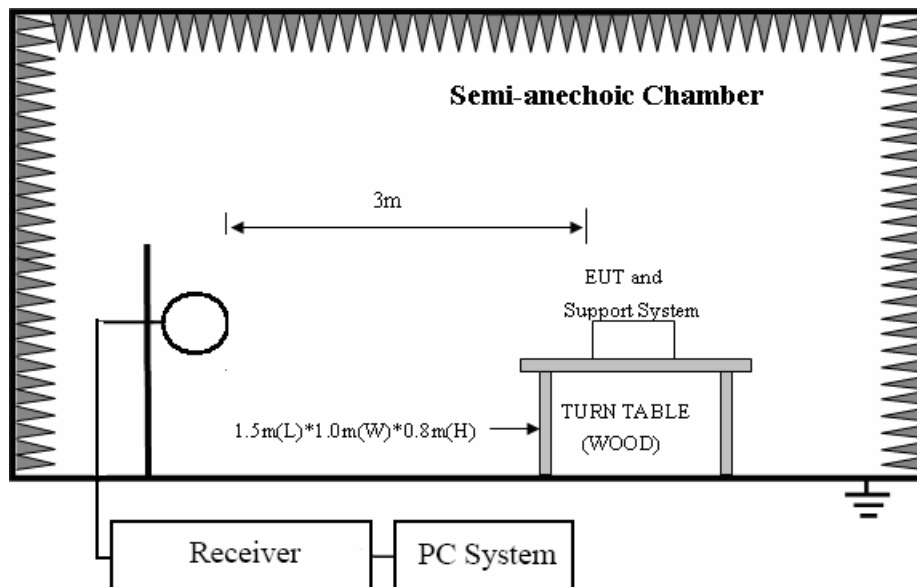

In 3m Anechoic Chamber Test Setup Diagram for 30MHz-1GHz

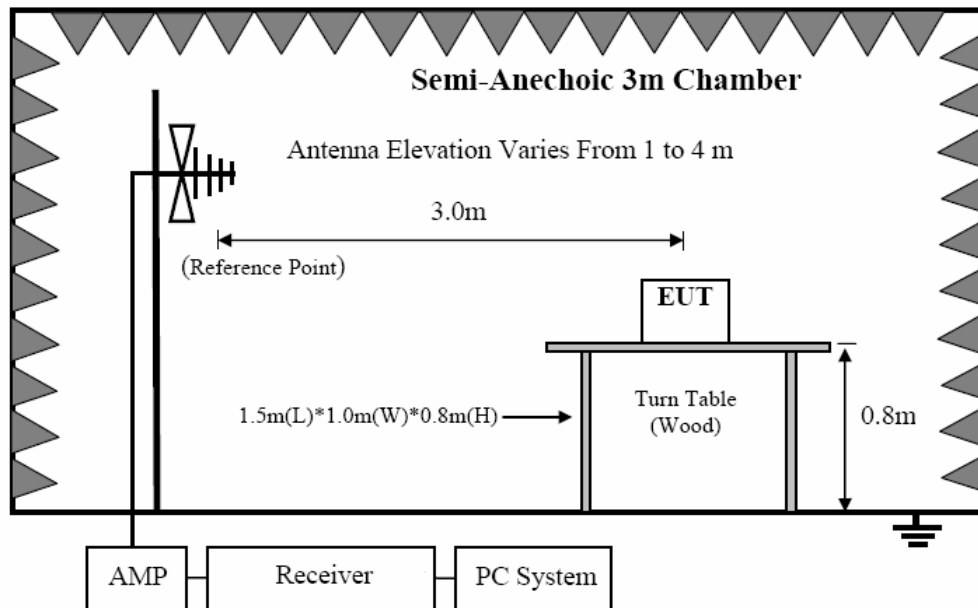

In 3m Anechoic Chamber Test Setup Diagram for frequency above 1GHz

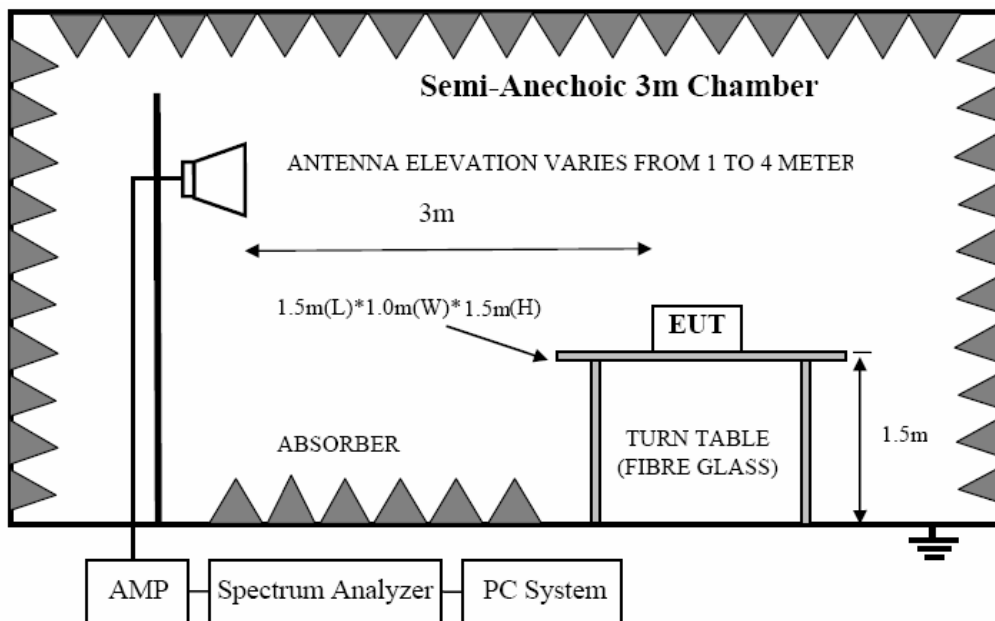

Note: For harmonic emissions test a appropriate high pass filter was inserted in the input port of AMP.

8.3.LIMIT

8.3.1. FCC 15.205 Restricted frequency band

MHz	MHz	MHz	GHz
0.090 - 0.110	16.42 - 16.423	399.9 - 410	4.5 - 5.15
¹ 0.495 - 0.505	16.69475 - 16.69525	608 - 614	5.35 - 5.46
2.1735 - 2.1905	16.80425 - 16.80475	960 - 1240	7.25 - 7.75
4.125 - 4.128	25.5 - 25.67	1300 - 1427	8.025 - 8.5
4.17725 - 4.17775	37.5 - 38.25	1435 - 1626.5	9.0 - 9.2
4.20725 - 4.20775	73 - 74.6	1645.5 - 1646.5	9.3 - 9.5
6.215 - 6.218	74.8 - 75.2	1660 - 1710	10.6 - 12.7
6.26775 - 6.26825	108 - 121.94	1718.8 - 1722.2	13.25 - 13.4
6.31175 - 6.31225	123 - 138	2200 - 2300	14.47 - 14.5
8.291 - 8.294	149.9 - 150.05	2310 - 2390	15.35 - 16.2
8.362 - 8.366	156.52475 - 156.52525	2483.5 - 2500	17.7 - 21.4
8.37625 - 8.38675	156.7 - 156.9	2690 - 2900	22.01 - 23.12
8.41425 - 8.41475	162.0125 - 167.17	3260 - 3267	23.6 - 24.0
12.29 - 12.293	167.72 - 173.2	3332 - 3339	31.2 - 31.8
12.51975 - 12.52025	240 - 285	3345.8 - 3358	36.43 - 36.5
12.57675 - 12.57725	322 - 335.4	3600 - 4400	(²)

8.3.2. FCC 15.209 Limit.

FREQUENCY MHz	DISTANCE Meters	FIELD STRENGTHS LIMIT	
		μV/m	dB(μV)/m
0.009 ~ 0.490	300	2400/F(KHz)	67.6-20log(F)
0.490 ~ 1.705	30	24000/F(KHz)	87.6-20log(F)
1.705 ~ 30.0	30	30	29.54
30 ~ 88	3	100	40.0
88 ~ 216	3	150	43.5
216 ~ 960	3	200	46.0
960 ~ 1000	3	500	54.0
Above 1000	3	74.0 dB(μV)/m (Peak) 54.0 dB(μV)/m (Average)	

Note: (1) The emission limits shown in the above table are based on measurements employing a CISPR QP detector except for the frequency bands 9-90KHz, 110-490KHz and above 1000MHz. Radiated emissions limits in these three bands are based on measurements employing an average detector.

(2) At frequencies below 30MHz, measurement may be performed at a distance closer then that specified, and the limit at closer measurement distance can be extrapolated by below formula:

$$\text{Limit}_{3m}(\text{dBuV/m}) = \text{Limit}_{30m}(\text{dBuV/m}) + 40\text{Log}(30\text{m}/3\text{m})$$

8.3.3. Limit for this EUT

All the emissions appearing within 15.205 restricted frequency bands shall not exceed the limits shown in 15.209, all the other emissions shall be at least 30dB below the fundamental emissions, or comply with 15.209 limits.

8.4. TEST PROCEDURE

- (1) EUT was placed on a non-metallic table, 80 cm above the ground plane inside a semi-anechoic chamber.
- (2) Setup EUT and assistant system according clause 2.4 and 7.2
- (3) Test antenna was located 3m from the EUT on an adjustable mast, and the antenna used as below table.

Test frequency range	Test antenna used
9KHz-30MHz	Active Loop antenna
30MHz-1GHz	Trilog Broadband Antenna
1GHz-18GHz	Double Ridged Horn Antenna(1GHz-18GHz)
18GHz-40GHz	Horn Antenna(18GHz-40GHz)

According ANSI C63.10:2013 clause 6.4.4.2 and 6,5.3, for measurements below 30 MHz, the loop antenna was positioned with its plane vertical from the EUT and rotated about its vertical axis for maximum response at each azimuth position around the EUT. And the loop antenna also be positioned with its plane horizontal at the specified distance from the EUT. The center of the loop is 1 m above the ground. for measurement above 30MHz, the Trilog Broadband Antenna or Horn Antenna was located 3m from EUT, Measurements were made with the antenna positioned in both the horizontal and vertical planes of Polarization, and the measurement antenna was varied from 1 m to 4 m. in height above the reference ground plane to obtain the maximum signal strength.

- (4) Below pre-scan procedure was first performed in order to find prominent frequency spectrum radiated emissions from 9KHz to 25GHz:
 - (a) Scanning the peak frequency spectrum with the antenna specified in step (3), and the EUT was rotated 360 degree, the antenna height was varied from 1m to 4m(Except loop antenna, it's fixed 1m above ground.)
 - (b) Change work frequency or channel of device if practicable.
 - (c) Change modulation type of device if practicable.
 - (d) Change power supply range from 85% to 115% of the rated supply voltage
 - (e) Rotated EUT though three orthogonal axes to determine the attitude of EUT arrangement produces highest emissions.

Spectrum frequency from 9KHz to 25GHz (tenth harmonic of fundamental frequency) was investigated, and no any obvious emission were detected from 18GHz to 25GHz, so below final test was performed with frequency range from 9KHz to 18GHz.

- (5) For final emissions measurements at each frequency of interest, the EUT was rotated and the antenna height was varied between 1m and 4m in order to maximize the emission. Measurements in both horizontal and vertical polarities were made and the data was recorded. In order to find the maximum emission, the relative positions of equipments and all of the interface cables were changed according to ANSI C63.10:2013 on Radiated Emission test.
- (6) The emissions from 9KHz to 1GHz were measured based on CISPR QP detector except for the frequency bands 9-90KHz, 110-490KHz, for emissions from 9KHz-90KHz,110KHz-490KHz and above 1GHz were measured based on average detector, for emissions above 1GHz, peak emissions also be measured and need comply with Peak limit.
- (7) The emissions from 9KHz to 1GHz, QP or average values were measured with EMI receiver with below RBW

Frequency band	RBW
9KHz-150KHz	200Hz
150KHz-30MHz	9KHz
30MHz-1GHz	120KHz

- (8) For emissions above 1GHz, both Peak and Average level were measured with Spectrum Analyzer, and the RBW is set at 1MHz, VBW is set at 3MHz for Peak measure; RBW is set at 1MHz, VBW is set at 10Hz for Average measure(according ANSI C63.10:2013 clause 4.2.3.2.3 procedure for average measure). Peak detector is used for Peak and AV measurement both.

8.5. TEST RESULT

PASS. (See below detailed test result)

All the emissions except fundamental emission from 9KHz to 25GHz were comply with 15.209 limit.

Note1: According exploratory test no any obvious emission were detected from 9KHz to 30MHz and 18GHz to 25GHz, so the final test was performed with frequency range from 30MHz to 18GHz and recorded in below.

Note2: For below test data, when the limit tabular marked "/" means this frequency point is the fundamental emission and no need comply with this limit.

Test Result

Test Site : 3m Chamber
EUT : AG WIRELESS
 : CONTROLLER FOR PS3 **Tested By** : Lake Hu
Power Supply : 5Vdc by notebook supply; **Model Number** : 064-015R
Condition : Temp:24.5'C,Humi:55%,
 : Press:100.1kPa **Test Mode** : Tx mode
Memo : GFSK **Antenna/Distance** : VULB 9163 /3m

Frequency (MHz)	Receiver		Rx Antenna		Cable loss (dB)	Amplifier Gain (dB)	Corrected Amplitude (dBμV/m)	FCC 15.247	
	Reading (dBμV)	PK/QP/AV	Polar (H/V)	Factor (dB)				Limit (dBμV/m)	Margin (dB)
Low Channel (2402)									
4804	45.28	PK	H	32.3	5.91	31.78	51.71	74	-22.29
4804	28.47	AV	H	32.3	5.91	31.78	34.9	54	-19.1
4804	46.59	PK	V	32.3	5.91	31.78	53.02	74	-20.98
4804	29.22	AV	V	32.3	5.91	31.78	35.65	54	-18.35
7206	33.14	PK	H	36.3	6.34	30.97	44.81	74	-29.19
7206	20.59	AV	H	36.3	6.34	30.97	32.26	54	-21.74
7206	35.16	PK	V	36.3	6.34	30.97	46.83	74	-27.17
7206	20.03	AV	V	36.3	6.34	30.97	31.7	54	-22.3
9608	28.47	PK	H	37.9	8.01	30.86	43.52	74	-30.48
9608	14.95	AV	H	37.9	8.01	30.86	30	54	-24
9608	29.38	PK	V	37.9	8.01	30.86	44.43	74	-29.57
9608	15.76	AV	V	37.9	8.01	30.86	30.81	54	-23.19
231.65	38.51	QP	H	14.2	2.74	27.6	27.85	46	-18.15
223.71	40.69	QP	V	14.2	2.74	27.6	30.03	46	-15.97
Middle Channel (2441)									
4882	45.05	PK	H	32.9	6.34	31.78	52.51	74	-21.49
4882	27.59	AV	H	32.9	6.34	31.78	35.05	54	-18.95
4882	46.71	PK	V	32.9	6.34	31.78	54.17	74	-19.83
4882	29.34	AV	V	32.9	6.34	31.78	36.8	54	-17.2
7323	33.06	PK	H	37.1	6.72	30.97	45.91	74	-28.09
7323	19.58	AV	H	37.1	6.72	30.97	32.43	54	-21.57
7323	34.16	PK	V	37.1	6.72	30.97	47.01	74	-26.99
7323	19.78	AV	V	37.1	6.72	30.97	32.63	54	-21.37
9764	28.05	PK	H	38.6	8.43	30.86	44.22	74	-29.78
9764	14.66	AV	H	38.6	8.43	30.86	30.83	54	-23.17

9764	28.07	PK	V	38.6	8.43	30.86	44.24	74	-29.76
9764	15.32	AV	V	38.6	8.43	30.86	31.49	54	-22.51
232.04	37.49	QP	H	14.2	2.74	27.6	26.83	46	-19.17
223.89	40.15	QP	V	14.2	2.74	27.6	29.49	46	-16.51
High Channel (2480)									
4960	43.56	PK	H	33.1	6.39	31.78	51.27	74	-22.73
4960	26.47	AV	H	33.1	6.39	31.78	34.18	54	-19.82
4960	45.22	PK	V	33.1	6.39	31.78	52.93	74	-21.07
4960	27.94	AV	V	33.1	6.39	31.78	35.65	54	-18.35
7440	32.29	PK	H	37.2	6.77	30.97	45.29	74	-28.71
7440	20.14	AV	H	37.2	6.77	30.97	33.14	54	-20.86
7440	33.62	PK	V	37.2	6.77	30.97	46.62	74	-27.38
7440	17.95	AV	V	37.2	6.77	30.97	30.95	54	-23.05
9920	28.58	PK	H	38.7	8.48	30.86	44.9	74	-29.1
9920	15.42	AV	H	38.7	8.48	30.86	31.74	54	-22.26
9920	28.08	PK	V	38.7	8.48	30.86	44.4	74	-29.6
9920	15.63	AV	V	38.7	8.48	30.86	31.95	54	-22.05
231.36	37.84	QP	H	14.2	2.74	27.6	27.18	46	-18.82
224.17	41.61	QP	V	14.2	2.74	27.6	30.95	46	-15.05

Note: 1. Result Level = Read Level + Antenna Factor + Cable Loss-Amp Gain
 2. If Peak Result comply with QP limit, QP Result is deemed to comply with QP limit

9. BAND EDGE

9.1. TEST EQUIPMENT

Item	Equipment	Manufacturer	Model No.	Serial No.	Cal Due.	Cal. Interval
1	EMI Test Receiver	R&S	ESU8	100316	2015/12/26	1 Year
2	Spectrum analyzer	R&S	FSU	1166.1660.26	2016/07/11	1 Year
3	Trilog Broadband Antenna	Schwarzbeck	VULB9163	9163-462	2015/12/26	1 Year
4	Double Ridged Horn Antenna	R&S	HF907	100276	2015/12/26	1 Year
5	Pre-amplifier	A.H.	PAM0-0118	360	2015/12/26	1 Year
6	RF Cable	R&S	R01	10403	2015/12/26	1 Year
7	RF Cable	R&S	R02	10512	2015/12/26	1 Year

9.2. BLOCK DIAGRAM OF TEST SETUP

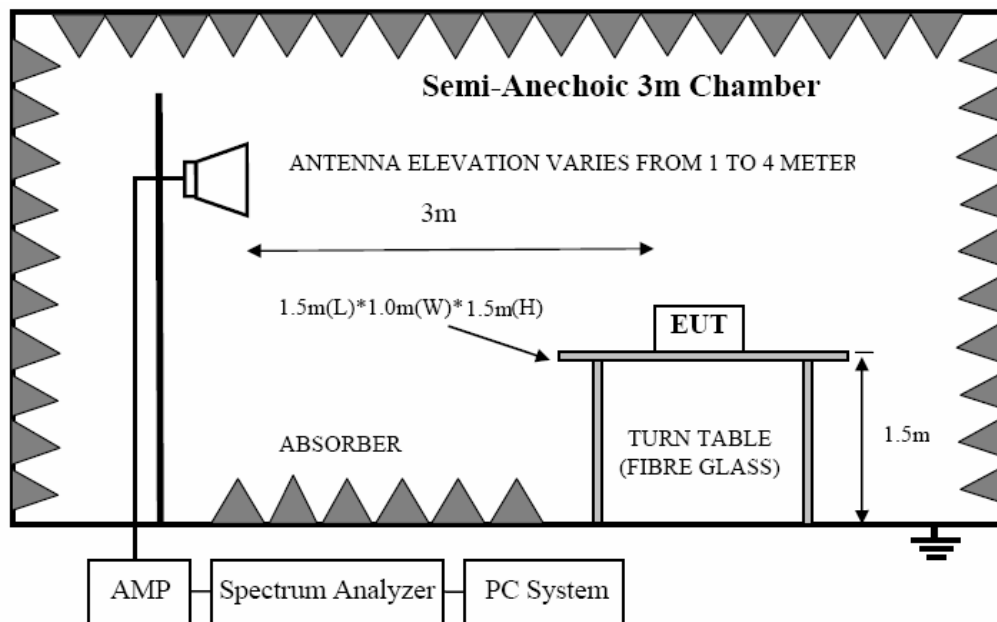

9.3.LIMIT

All the lower and upper band-edges emissions appearing within 2310MHz to 2390MHz and 2483.5MHz to 2500MHz restricted frequency bands shall not exceed the limits shown in 15.209, all the other emissions outside operation frequency band 2400MHz to 2483.5MHz shall be at least 20dB below the fundamental emissions, or comply with 15.209 limits.

9.4.TEST PROCEDURE

Same with clause 8.4 except change investigated frequency range from 2100MHz to 2450MHz and 2450MHz to 2500MHz.

Remark: All restriction band have been tested, and only the worse case is shown in report.

9.5.TEST RESULT

Frequency (MHz)	Receiver		Rx Antenna		Cable loss (dB)	Amplifier Gain (dB)	Corrected Amplitude (dBμV/m)	FCC 15.205	
	Reading (dBμV)	PK/QP/AV	Polar (H/V)	Factor (dB)				Limit (dBμV/m)	Margin (dB)
Lowest Channel (GFSK)									
2390	23.47	PK	H	27.8	3.57	0	54.84	74	-19.16
2390	10.08	AV	H	27.8	3.57	0	41.45	54	-12.55
2390	23.34	PK	V	27.8	3.57	0	54.71	74	-19.29
2390	10.22	AV	V	27.8	3.57	0	41.59	54	-12.41
2400	31.13	PK	H	28	3.57	0	62.7	74	-11.3
2400	12.21	AV	H	28	3.57	0	43.78	54	-10.22
2400	28.10	PK	V	28	3.57	0	59.67	74	-14.33
2400	10.05	AV	V	28	3.57	0	41.62	54	-12.38
Highest Channel (GFSK)									
2483.5	23.06	PK	H	28.7	3.72	0	55.48	74	-18.52
2483.5	9.59	AV	H	28.7	3.72	0	42.01	54	-11.99
2483.5	23.43	PK	V	28.7	3.72	0	55.85	74	-18.15
2483.5	9.61	AV	V	28.7	3.72	0	42.03	54	-11.97

Note: 1. Result Level = Read Level + Antenna Factor + Cable Loss- Amplifier Gain
 2. After test and evaluation hopping off mode and hopping on mode, will record worst case (hopping off mode) in this report.

10. Conducted Spurious Emissions

10.1. Test Equipment

Item	Equipment	Manufacturer	Model No.	Serial No.	Cal Due.	Cal. Interval
1	Spectrum analyzer	R&S	FSU	1166.1660.26	2015/12/26	1 Year
2	Attenuator	Mini-Circuits	BW-S10W2	101109	2015/12/26	1 Year
3	RF Cable	Micable	C10-01-01-1	100309	2015/12/26	1 Year

10.2. Limit

In any 100kHz bandwidth outside the frequency bands in which the spread spectrum intentional radiator is operating, the radio frequency power that is produced by the intentional radiator shall be at least 20dB below that in the 100kHz bandwidth within the band that contains the highest level of the desired power.

10.3. Test Procedure

The transmitter output was connected to a spectrum analyzer, The resolution bandwidth is set to 100 kHz, The video bandwidth is set to 300 kHz and measure all the emissions detected.

10.4. Test result

PASS (See below detailed test result.)

GFSK

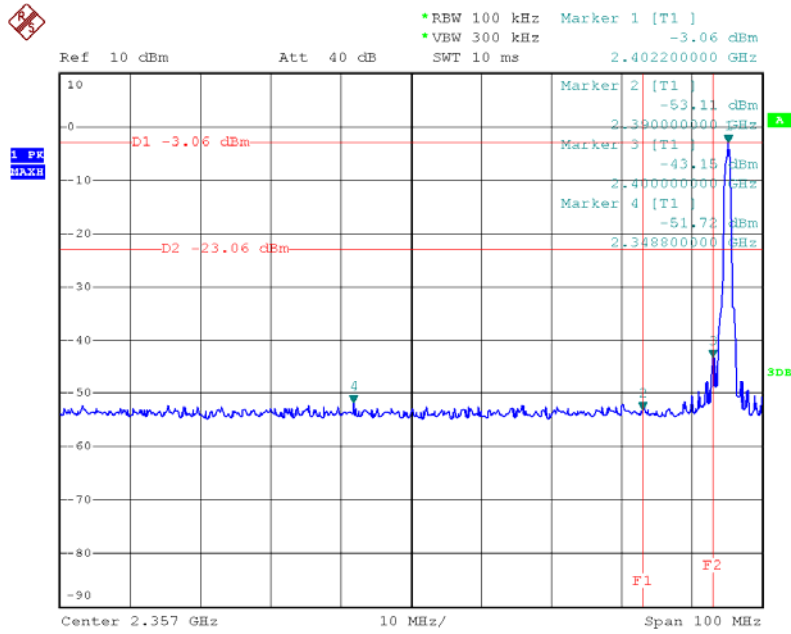

Date: 17.SEP.2015 16:13:54

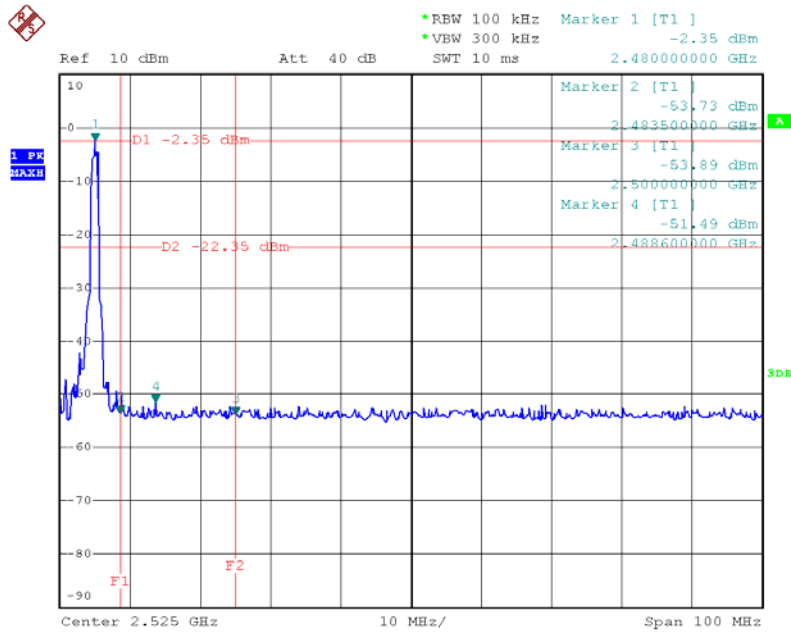

Date: 17.SEP.2015 16:14:50

GFSK 2402MHz

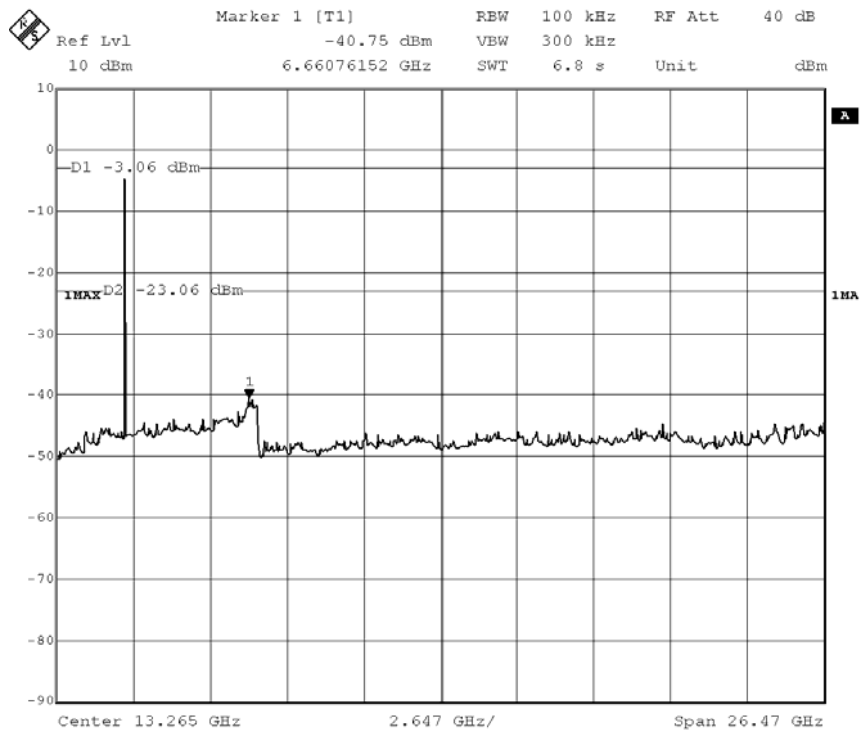

GFSK 2441MHz

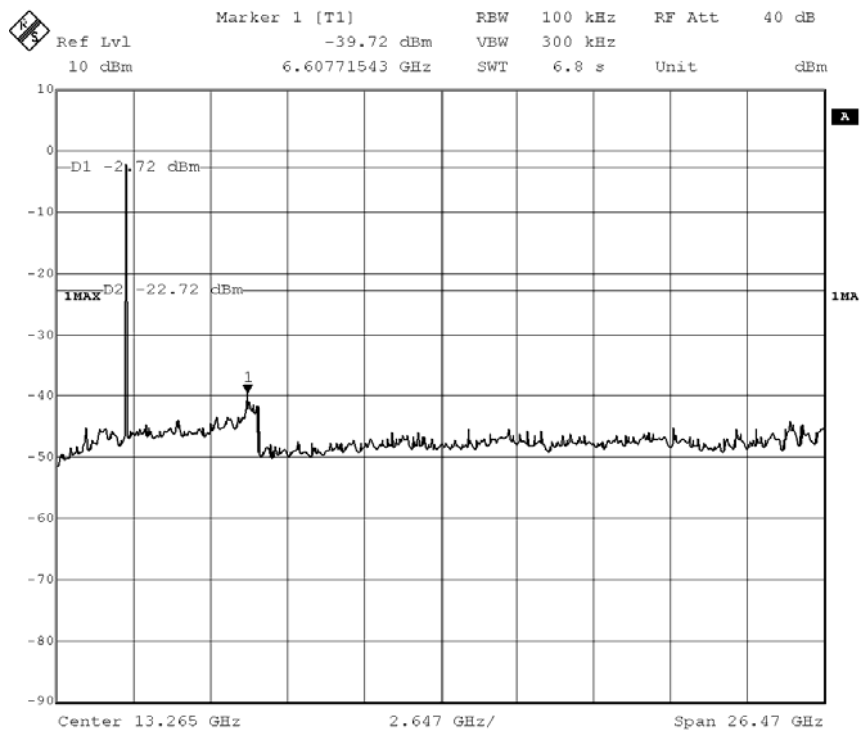

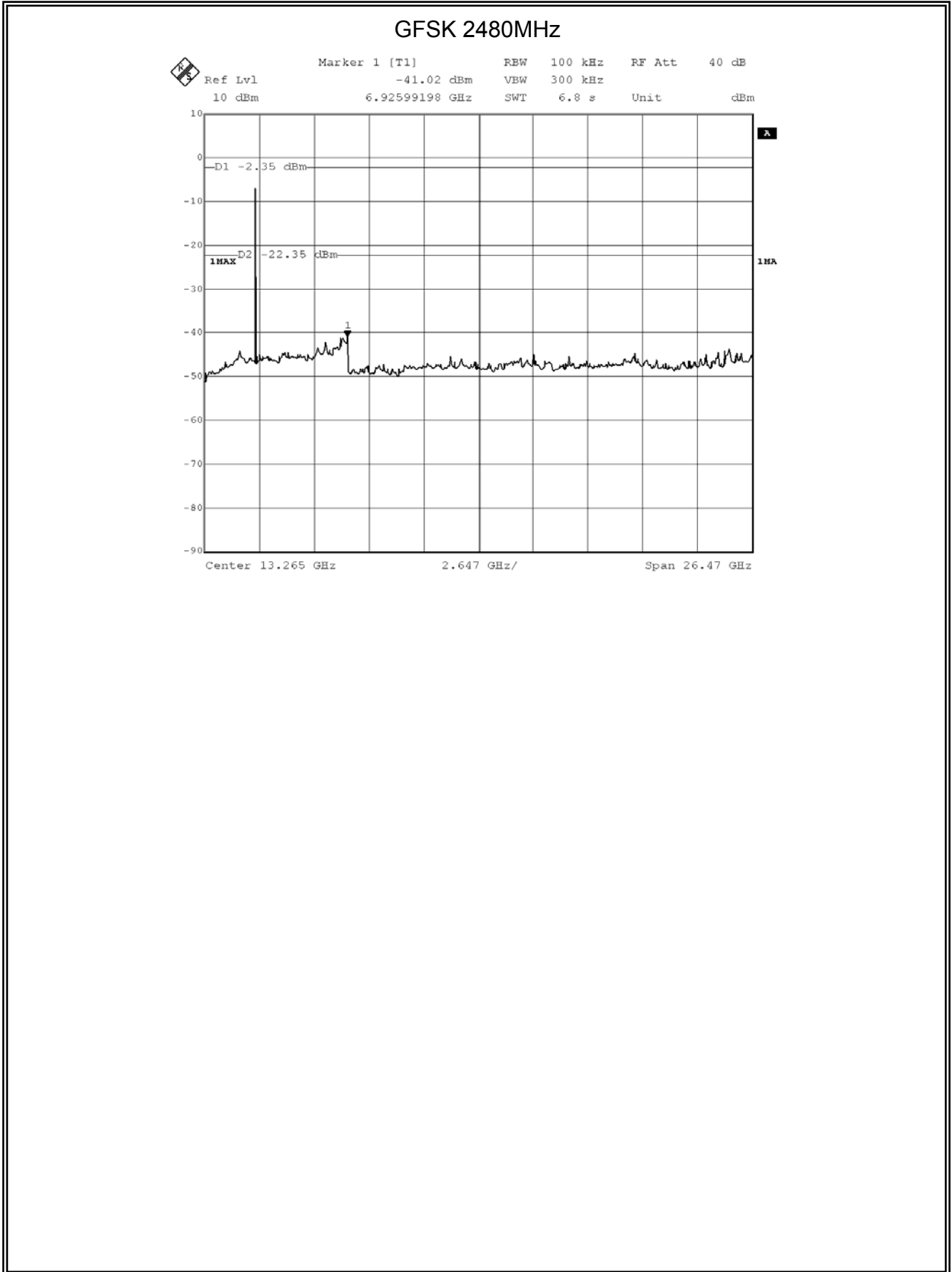

11. Power Line Conducted Emission

11.1. Test equipment

Item	Equipment	Manufacturer	Model No.	Serial No.	Cal Due.	Cal. Interval
1	Test Receiver	R&S	ESCI	101308	2015/12/26	1 Year
2	LISN 1	AFJ	LS16	16011103219	2015/12/26	1 Year
3	LISN 2	R&S	ESH2-Z5	100309	2015/12/26	1 Year
4	Pulse Limiter	MTS-systemtechnik	MTS-IMP-136	261115-010-0024	2015/12/26	1 Year

11.2. Block diagram of test setup

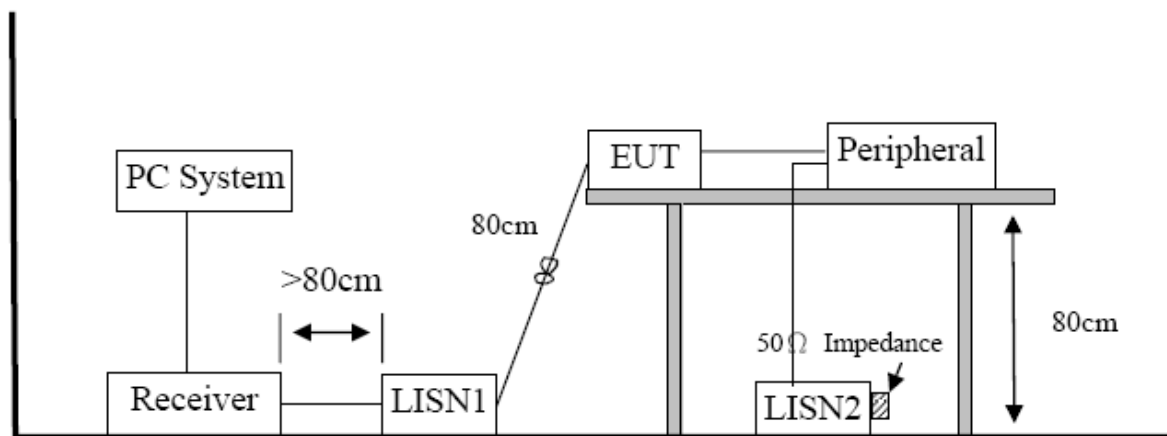

11.3. Power Line Conducted Emission Limits (Class B)

Frequency	Quasi-Peak Level dB(μ V)	Average Level dB(μ V)
150kHz ~ 500kHz	66 ~ 56*	56 ~ 46*
500kHz ~ 5MHz	56	46
5MHz ~ 30MHz	60	50

Note 1: * Decreasing linearly with logarithm of frequency.

Note 2: The lower limit shall apply at the transition frequencies

11.4. Test Procedure

The EUT and Support equipment, if needed, were put placed on a non-metallic table, 80cm above the ground plane. Configuration EUT to simulate typical usage as described in clause 2.4 and test equipment as described in clause 10.2 of this report. All I/O cables were positioned to simulate typical actual usage as per ANSI C63.4: 2009. All support equipment power received from a second LISN. Emissions were measured on each current carrying line of the EUT using an EMI Test Receiver connected to the LISN powering the EUT. The Receiver scanned from 150 kHz to 30MHz for emissions in each of the test modes. During the above scans, the emissions were maximized by cable manipulation. The test mode(s) described in clause 2.4 were scanned during the preliminary test. After the preliminary scan, we found the test mode producing the highest emission level. The EUT configuration and worse cable configuration of the above highest emission levels were recorded for reference of the final test. EUT and support equipment were set up on the test bench as per the configuration with highest emission level in the preliminary test. A scan was taken on both power lines, Neutral and Line, recording at least the six highest emissions. Emission frequency and amplitude were recorded into a computer in which correction factors were used to calculate the emission level and compare reading to the applicable limit. The test data of the worst-case condition(s) was recorded. The bandwidth of test receiver is set at 9 KHz.

11.5. Test Result

EUT:	AG WIRELELL CONTROLLER FOR PS3	Model No.:	064-015R
Temperature:	24°C	Relative Humidity:	55%
Probe:	L1	Test Power:	AC 120V/60Hz
Standard:	(CE)FCC PART 15_B	Test Result:	Pass
Test Mode:	Tx	Test By:	Lake
Note:	2402MHz		

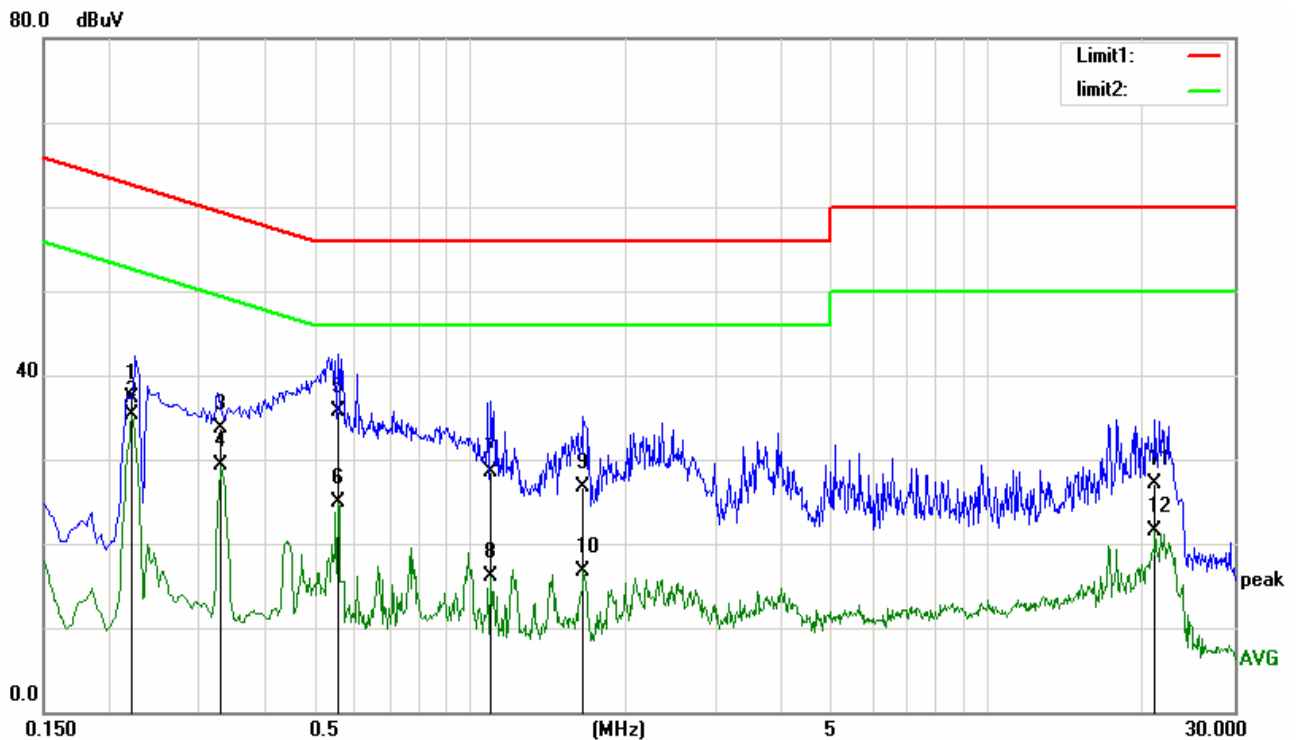

No.	Frequency (MHz)	Reading (dBuV)	Correct Factor(dB)	Result (dBuV)	Limit (dBuV)	Margin (dB)	Remark
1	0.2220	26.38	10.97	37.35	62.74	-25.39	QP
2	0.2220	24.34	10.97	35.31	52.74	-17.43	AVG
3	0.3300	23.25	10.40	33.65	59.45	-25.80	QP
4	0.3300	18.87	10.40	29.27	49.45	-20.18	AVG
5	0.5580	25.55	10.16	35.71	56.00	-20.29	QP
6	0.5580	14.66	10.16	24.82	46.00	-21.18	AVG
7	1.0940	18.48	10.10	28.58	56.00	-27.42	QP
8	1.0940	6.05	10.10	16.15	46.00	-29.85	AVG
9	1.6580	16.58	10.11	26.69	56.00	-29.31	QP
10	1.6580	6.69	10.11	16.80	46.00	-29.20	AVG
11	21.1140	16.96	10.18	27.14	60.00	-32.86	QP
12	21.1140	11.25	10.18	21.43	50.00	-28.57	AVG

EUT:	AG WIRELELL CONTROLLER FOR PS3	Model No.:	064-015R
Temperature:	24°C	Relative Humidity:	55%
Probe:	N	Test Power:	AC 120V/60Hz
Standard:	(CE)FCC PART 15_B	Test Result:	Pass
Test Mode:	Tx	Test By:	Lake
Note:	2402MHz		

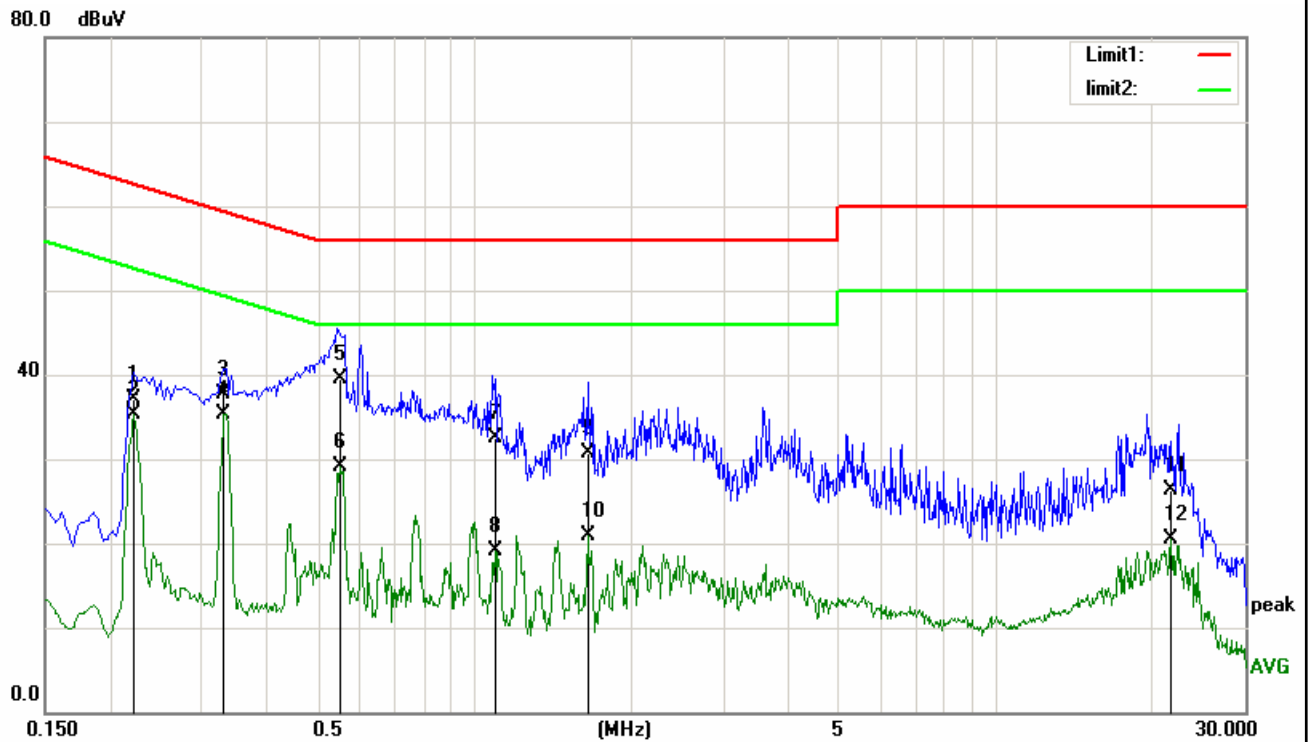

No.	Frequency (MHz)	Reading (dBuV)	Correct Factor(dB)	Result (dBuV)	Limit (dBuV)	Margin (dB)	Remark
1	0.2220	26.19	10.97	37.16	62.74	-25.58	QP
2	0.2220	24.28	10.97	35.25	52.74	-17.49	AVG
3	0.3300	27.38	10.40	37.78	59.45	-21.67	QP
4	0.3300	24.98	10.40	35.38	49.45	-14.07	AVG
5	0.5540	29.34	10.16	39.50	56.00	-16.50	QP
6	0.5540	18.85	10.16	29.01	46.00	-16.99	AVG
7	1.0940	22.46	10.10	32.56	56.00	-23.44	QP
8	1.0940	8.94	10.10	19.04	46.00	-26.96	AVG
9	1.6457	20.60	10.11	30.71	56.00	-25.29	QP
10	1.6457	10.87	10.11	20.98	46.00	-25.02	AVG
11	21.6619	16.10	10.17	26.27	60.00	-33.73	QP
12	21.6619	10.29	10.17	20.46	50.00	-29.54	AVG

12.ANTENNA REQUIREMENTS

12.1. Limit

For intentional device, according to FCC 47 CFR Section 15.203, an intentional radiator shall be designed to ensure that no antenna other than that furnished by the responsible party shall be used with the device. And according to FCC 47 CFR Section 15.247 (b), if transmitting antennas of directional gain greater than 6dBi are used, the power shall be reduced by the amount in dB that the directional gain of the antenna exceeds 6dBi.

12.2. RESULT

The antennas used for this product are dipole antenna and other than that furnished by the responsible party shall be used with the device, the maximum peak gain of the transmit antenna is only -0.61dBi. The EUT has an internal antenna, the directional gain of antenna is -0.61dBi, and the antenna connector is designed with permanent attachment and no consideration of replacement. Therefore the EUT is considered sufficient to comply with the provision.

END OF REPORT