

# LVL50

FOR  
POUR  
PS4®

## WIRELESS HEADSET CASQUE-MICRO SANS FIL

LVL50 Wireless Stereo Headset for PS4

051-049

Quick Start Guide  
Guide De Démarrage Rapide  
Guia De Início Rápido  
Guia de início rápido

**!** Don't return this product to the store.  
Ne retournez pas ce produit au magasin.  
No devuelva este producto a la tienda.  
Não devolva este produto à loja.

Limited Warranty Information Inside  
Information sur la Garantie limitée à l'intérieur  
Información sobre la Garantía Limitada en el interior  
Informações sobre a garantia limitada na parte de dentro



- EN LVL50 Wireless Headset
- FR Casque-micro sans fil LVL50
- ES Auricular inalámbrico LVL50
- PT Fones de ouvido sem fio LVL50

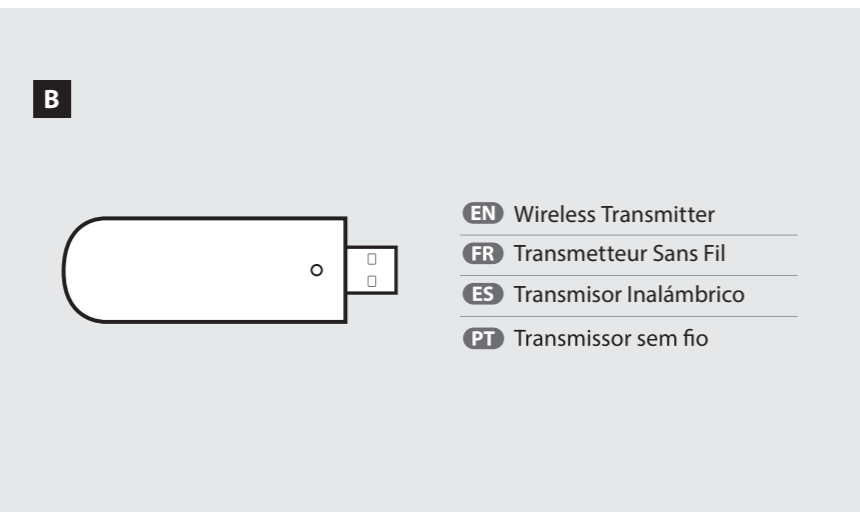

- EN Wireless Transmitter
- FR Transmetteur Sans Fil
- ES Transmisor Inalámbrico
- PT Transmissor sem fio

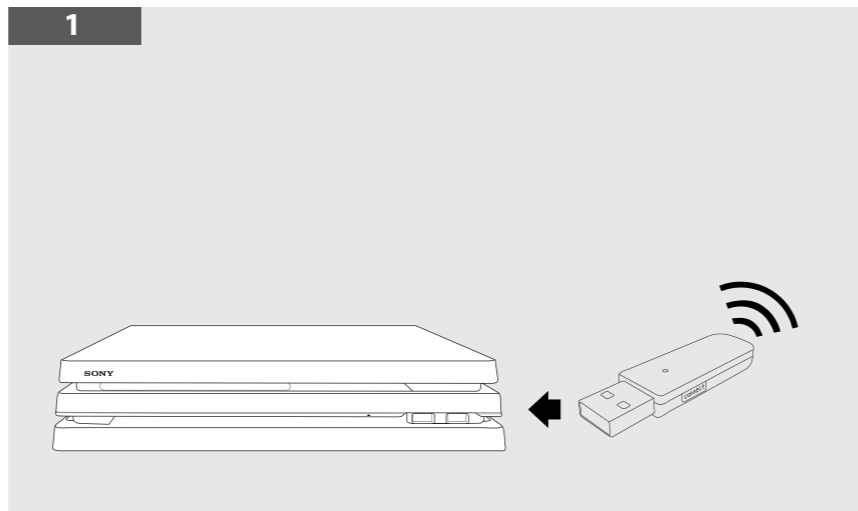

- EN **Pairing USB Transmitter**  
Press and hold button on USB Transmitter until LED flashes  
Press and hold Power button on headset until it pairs with USB Transmitter
- FR **Jumelage de l'émetteur USB**  
Maintenez le bouton enfoncé sur l'émetteur USB jusqu'à ce que la DEL clignote  
Maintenez le bouton d'alimentation enfoncé sur le casque-micro jusqu'à ce qu'il soit jumelé à l'émetteur USB
- ES **Conectando transmisor USB**  
Mantenga presionado el botón del transmisor USB hasta que el LED parpadee  
Mantenga presionado el botón "Power" (Encendido) del auricular hasta que se conecte con el transmisor USB
- PT **Emparelhamento com o Transmissor USB**  
Pressione e mantenha pressionado o botão no Transmissor USB até o LED ficar intermitente  
Pressione e mantenha pressionado o botão Ligar/Desligar nos fones de ouvido até o emparelhamento com o Transmissor USB ser concluído

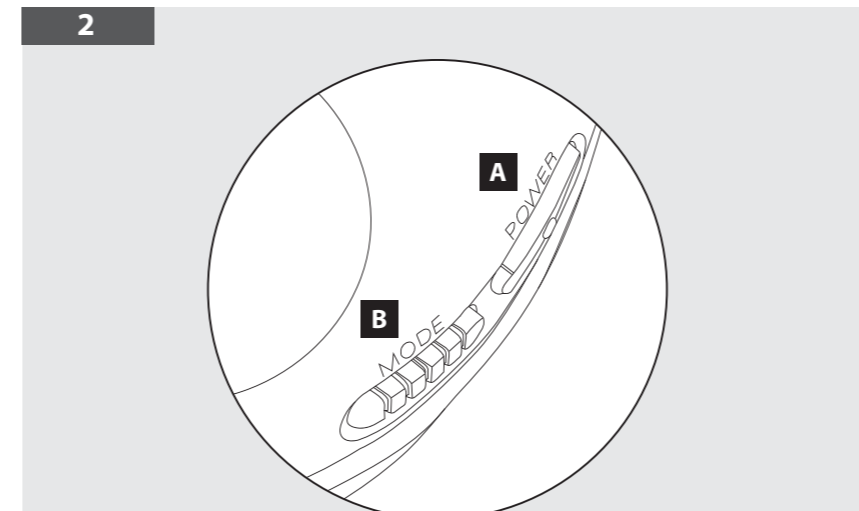

- EN **a. Power on**  
Press power button to turn on headset
- EN **b. Switching Audio Modes**  
Press Mode button to switch between Pure Audio and Bass Boost
- FR **a. Mise sous tension**  
Appuyez sur le bouton d'alimentation pour mettre en marche le casque-micro
- FR **b. Changer les modes audio**  
Appuyez sur le bouton Mode pour passer entre l'audio pur et l'amplification des basses
- ES **a. Encendido**  
Presione el botón Power (Encendido) para encender el auricular
- ES **b. Cambio de modos de audio**  
Presione el botón "Mode" (Modo) para cambiar entre los modos Audio puro y Potenciador de graves
- PT **a. Ligar/Desligar**  
Pressione o botão Ligar/Desligar para ligar os fones de ouvido
- PT **b. Como alternar os modos de áudio**  
Pressione o botão Modo para alternar entre Áudio Puro e Reforço de Graves

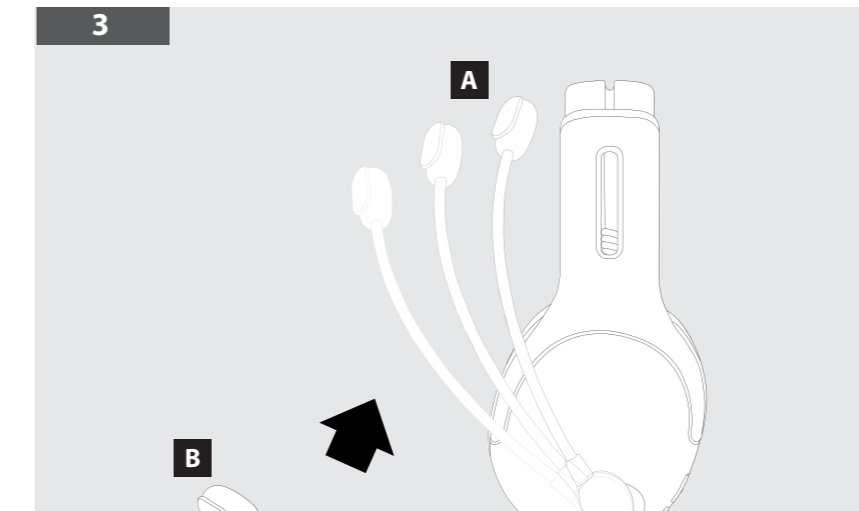

- EN **Mic Mute**  
a. Mic Boom up to mute  
b. Mic Boom down to unmute
- FR **Mic en sourdine**  
a. Micro vers le haut pour la mise en sourdine  
b. Micro vers le bas pour la mise en marche
- ES **Silenciar micrófono**  
a. Suba el micrófono Boom para silenciar  
b. Baje el micrófono Boom reactivar el sonido
- PT **Como ativar/desativar o microfone**  
a. Levante o microfone para ativar o modo b. Abaixar o microfone para desativar o modo
- EN **Mic Monitoring**  
Allows you to hear your voice through the headset when you speak
- FR **Contrôle du micro**  
Permet d'entendre votre voix dans le casque-micro lorsque vous parlez
- ES **Monitoreo del micrófono**  
Le permite escuchar su voz por el auricular cuando habla
- PT **Monitoramento do microfone**  
Permite que você ouça sua voz nos fones de ouvido ao falar

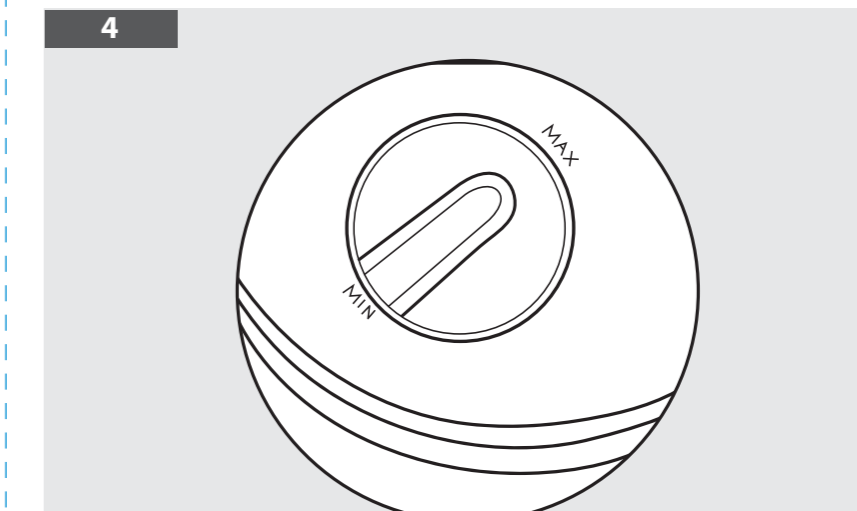

- EN **Adjust Volume**  
Turn volume dial on right ear cup to preferred audio level
- FR **Ajuster le volume**  
Tournez la molette de volume sur l'oreillette de droite au niveau audio de votre choix
- ES **Ajustar volumen**  
Gire el dial de volumen del auricular derecho al nivel de audio preferido
- PT **Como ajustar o volume**  
Gire o regulador de volume no fone de ouvido direito para o nível de áudio desejado

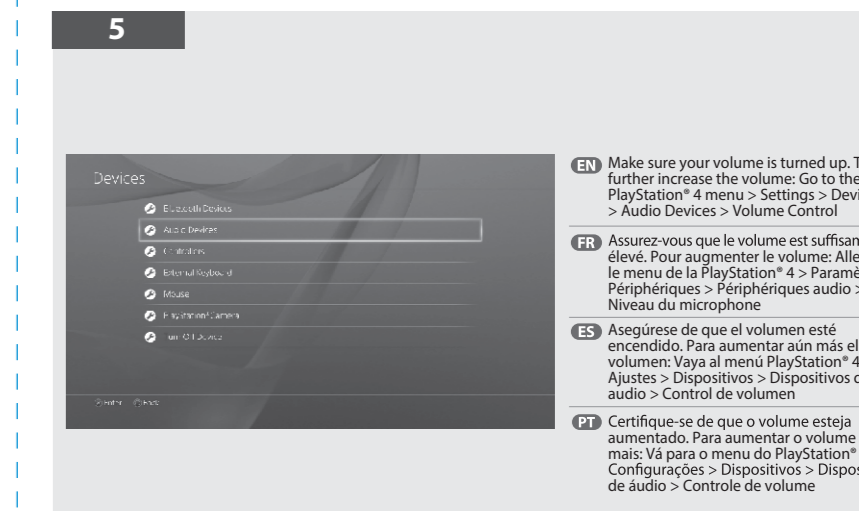

- EN Make sure your volume is turned up. To further increase the volume: Go to the PlayStation®4 menu > Settings > Devices > Audio Devices > Volume Control
- FR Assurez-vous que le volume est suffisamment élevé. Pour augmenter le volume: Allez sur le menu de la PlayStation®4 > Paramètres > Périphériques > Périphériques audio > Niveau du microphone
- ES Asegúrese de que el volumen esté encendido. Para aumentar aún más el volumen: Vaya al menú PlayStation®4 > Ajustes > Dispositivos > Dispositivos de audio > Control de volumen
- PT Certifique-se de que o volume esteja aumentado. Para aumentar o volume ainda mais: Vá para o menu do PlayStation®4 > Configurações > Dispositivos > Dispositivos de áudio > Controle de volume

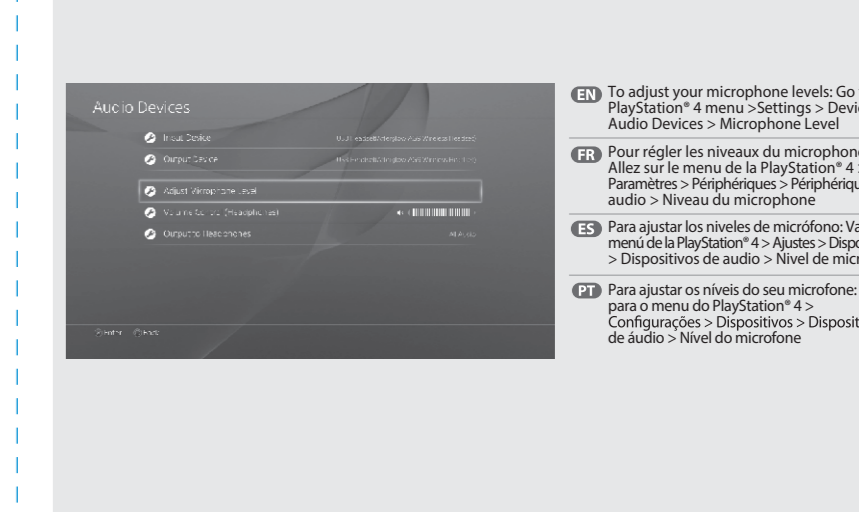

- EN To adjust your microphone levels: Go to PlayStation®4 menu > Settings > Devices > Audio Devices > Microphone Level
- FR Pour régler les niveaux du microphone: Allez sur le menu de la PlayStation®4 > Paramètres > Périphériques > Périphériques audio > Niveau du microphone
- ES Para ajustar los niveles de microfono: Vaya al menú de la PlayStation®4 > Configuraciones > Dispositivos > Dispositivos de audio > Nivel de microfono
- PT Para ajustar os níveis do seu microfone: Vá para o menu do PlayStation®4 > Configurações > Dispositivos > Dispositivos de áudio > Nível do microfone

©2018 Performance Designed Products LLC. Performance Designed Products, PDP, PDPgaming, Afterglow and their respective logos are trademarks and/or registered trademarks of Performance Designed Products LLC. All rights reserved. All other logos and trademarks are property of their respective owners. Manufactured and Distributed under license from Sony Interactive Entertainment LLC.  
"PS", "PlayStation" and "PS4" are registered trademarks of Sony Interactive Entertainment Inc. All rights reserved.  
©2018 Performance Designed Products LLC. Performance Designed Products, PDP, PDPgaming, Afterglow et leurs logos respectifs sont des marques commerciales et/ou marques déposées de Performance Designed Products LLC. Tous droits réservés. Tous les autres logos et toutes les autres marques de commerce sont la propriété de leurs détenteurs respectifs. Fabriqué et distribué sous licence de Sony Interactive Entertainment LLC.  
"PS", "PlayStation" et "PS4" sont des marques de commerce déposées de Sony Interactive Entertainment Inc. Tous droits réservés.  
©2018 Performance Designed Products LLC. Performance Designed Products, PDP, PDPgaming, Afterglow y sus respectivos logotipos son marcas comerciales o marcas registradas de Performance Designed Products LLC. Todos los derechos reservados. El resto de logotipos y marcas registradas son propiedad de sus respectivos dueños. Fabricado y distribuido bajo licencia de Sony Interactive Entertainment LLC.  
"PS", "PlayStation" y "PS4" são marcas comerciais registradas de Sony Interactive Entertainment Inc. Todos los derechos reservados.

©2018 Performance Design Products LLC. Performance Designed Products, PDP, PDPgaming, Afterglow e os respectivos logotipos são marcas comerciais e/ou marcas registradas da Performance Designed Products LLC. Todos os direitos reservados. As restantes logomarcas e marcas comerciais são propriedade dos respectivos proprietários. Fabricado e distribuído sob licenciamento por parte da Sony Interactive Entertainment LLC.  
"PS", "PlayStation" e "PS4" são marcas registradas da Sony Interactive Entertainment Inc. Todos os direitos reservados.

This Product is manufactured and imported by Performance Designed Products LLC.  
Ce produit est fabriqué et importé par Performance Designed Products LLC.  
Este producto está fabricado e importado por Performance Designed Products LLC.  
Este produto foi fabricado e importado pela Performance Designed Products LLC.

4225 W Buckeye Rd #2  
Phoenix, AZ 85009, USA  
Ph: 800-331-3844  
(USA & Canada only)

US Patents/Brevets aux É.-U.:  
www.pdp.com/patents

MADE IN CHINA/FABRIQUÉ EN CHINE/HECHO EN CHINA support.pdp.com

**FEDERAL COMMUNICATIONS COMMISSION INTERFERENCE STATEMENT**  
This equipment has been tested and found to comply with the limits for a Class B digital device, pursuant to part 15 of the FCC Rules. These limits are designed to provide reasonable protection against harmful interference in a residential installation. This equipment generates, uses and can radiate radio frequency energy and, if not installed and used in accordance with the instructions, may cause harmful interference to radio communications. However, there is no guarantee that interference will not occur in a particular installation. If this equipment does cause harmful interference to radio or television reception, which can be determined by turning the equipment off and on, the user is encouraged to try to correct the interference by one or more of the following measures:  
-Reorient or relocate the receiving antenna.  
-Increase the separation between the equipment and receiver.  
-Connect the equipment into an outlet on a circuit different from that to which the receiver is connected.  
-Consult the dealer or an experienced radio/TV technician for help.  
**CAUTION:**  
Any changes or modifications not expressly approved by the grantee of this device could void the user's authority to operate the equipment.  
**This device complies with Part 15 of the FCC Rules. Operation is subject to the following two conditions:**  
(1) this device may not cause harmful interference, and  
(2) this device must accept any interference received, including interference that may cause undesired operation.  
**RF exposure warning**  
The equipment complies with FCC RF exposure limits set forth for an uncontrolled environment.  
The equipment must not be co-located or operating in conjunction with any other antenna or transmitter.  
**RF exposure warning**  
This equipment must be installed and operated in accordance with provided instructions and the antenna(s) used for this transmitter must be installed to provide a separation distance of at least 20 cm from all persons and must not be co-located or operating in conjunction with any other antenna or transmitter. End-users and installers must be provided with antenna installation instructions and transmitter operating conditions for satisfying RF exposure compliance.

Canada, Innovation, Science and Economic Development Canada (ISED) Notices  
This device contains licence-exempt transmitter(s)/receiver(s) that comply with Innovation, Science and Economic Development Canada's licence-exempt RSS(s). Operation is subject to the following two conditions:  
(1) This device may not cause interference.  
(2) This device must accept any interference, including interference that may cause undesired operation of the device.

Avis du Canada, Innovation, Sciences et Développement économique Canada (ISED)  
L'émetteur/récepteur exempt de licence contenu dans le présent appareil est conforme aux CNR d'Innovation, Sciences et Développement économique Canada applicables aux appareils radio exempts de licence. L'exploitation est autorisée aux deux conditions suivantes:  
(1) L'appareil ne doit pas produire de brouillage;  
(2) L'appareil doit accepter tout brouillage radioélectrique subi, même si le brouillage est susceptible d'en compromettre le fonctionnement.

Radio Frequency (RF) Exposure Information  
The radiated output power of the Wireless Device is below the Innovation, Science and Economic Development Canada (ISED) radio frequency exposure limits. The Wireless Device should be used in such a manner such that the potential for human contact during normal operation is minimized.

This device has been evaluated for and shown compliant with the ISED Specific Absorption Rate ("SAR") limits when operated in portable exposure conditions.

Informations concernant l'exposition aux fréquences radio (RF)  
La puissance de sortie rayonnée du dispositif sans fil est inférieure aux limites d'exposition aux radiofréquences d'Innovation, Sciences et Développement économique Canada (ISED). Le dispositif sans fil doit être utilisé de manière à minimiser le potentiel de contact humain pendant le fonctionnement normal.  
Cet appareil a été évalué et montré conforme aux limites de DAS (Débit d'Absorption Spécifique) de l'ISED lorsqu'il est utilisé dans des conditions d'exposition portables.  
Radio Frequency (RF) Exposure Information  
The radiated output power of the Wireless Device is below the Innovation, Science and Economic Development Canada (ISED) radio frequency exposure limits. The Wireless Device should be used in such a manner such that the potential for human contact during normal operation is minimized.

This device has also been evaluated and shown compliant with the ISED RF Exposure limits under mobile exposure conditions. (antennas are greater than 20cm from a person's body).

Informations concernant l'exposition aux fréquences radio (RF)  
La puissance de sortie rayonnée du dispositif sans fil est inférieure aux limites d'exposition aux radiofréquences d'Innovation, Sciences et Développement économique Canada (ISED). Le dispositif sans fil doit être utilisé de manière à minimiser le potentiel de contact humain pendant le fonctionnement normal.  
Cet appareil a également été évalué et montré conforme aux limites d'exposition RF ISED dans des conditions d'exposition mobiles. (Les antennes sont à plus de 20 cm du corps d'une personne).

### ENGLISH LIMITED WARRANTY

**■ Coverage and Term** • PDP warrants that this product will be free from manufacturing defects for two years from the original date of purchase. Manufacturing defects are those defects in materials and/or workmanship, subject to final determination by PDP's customer service department. This warranty applies only to original purchasers with a valid proof of purchase from an authorized PDP retailer that clearly shows the date of purchase.

**■ Exclusive Remedy and Exclusions** • The exclusive remedy for valid claims will be the repair, replacement or refund of the product. This warranty does not cover defects caused by accidents, improper or abusive use of the product, unauthorized or improper modifications, repairs or handling.

**■ How to Get Service** • Purchasers should contact the PDP customer service department at (800) 331-3844 (US and Canada only) or +442036957905 (UK only) or by visiting support.pdp.com or support.pdp-eu.com. Inquiries are typically answered within twenty-four business hours.

**■ Your Rights Under Applicable Law** • This warranty does not affect the legal rights of customers under applicable state, provincial or national laws governing the sale of consumer goods.

**■ Additional Information for Australian Customers** • PDP products come with guarantees that cannot be excluded under the Australian Consumer Law. You are entitled to a replacement or refund for a major failure and compensation for any other reasonably foreseeable loss or damage. You are also entitled to have the goods repaired or replaced if the goods fail to be of acceptable quality and the failure does not amount to a major failure. The benefits given to you under our express warranty are in addition to other rights and remedies you have under the Australian Consumer Law and other laws.

### FRANÇAIS CANADA GARANTIE LIMITÉE

**■ Couverture et conditions** • PDP garantit que ce produit sera libre de défauts de fabrication pendant deux ans à partir de sa date originale d'achat. Les défauts de fabrication sont les défauts de matériaux ou de main-d'œuvre déterminés à la discrétion du service à la clientèle de PDP. Cette garantie s'applique uniquement aux acheteurs originaux disposant d'une preuve d'achat valide provenant d'un détaillant agréé de PDP qui illustre clairement la date d'achat.

**■ Recours exclusif et exclusions** • Le recours exclusif des réclamations considérées comme étant valides sera la réparation, le remplacement ou le remboursement du produit. Cette garantie ne couvre pas les défauts causés par les accidents, les usages inappropriés ou abusifs de ce produit, les modifications non autorisées ou inadéquates, les réparations ou les manutentions non autorisées.

**■ Comment obtenir du service** • Les acheteurs doivent contacter le service à la clientèle de PDP au (800) 331-3844 (États-Unis et Canada seulement) ou +442036957905 (Royaume-Uni seulement) ou en visitant le site support.pdp.com ou support.pdp-eu.com. Nous répondons habituellement aux réclamations dans un délai de 24 heures ouvrables.

**■ Vos droits en vertu des lois applicables** • Cette garantie n'affecte pas les droits légaux des clients en vertu des lois applicables dans chaque état, province ou pays régissant la vente de biens de consommation.

### ESPAÑOL GARANTÍA LIMITADA

**■ Cobertura y plazo** • PDP garantiza que este producto estará libre de defectos de fabricación durante dos años a partir de la fecha original de compra. Los defectos de fabricación son los defectos en los materiales o la mano de obra, sujetos a la determinación final del departamento de atención al cliente del PDP. Esta garantía se aplica solamente a los compradores originales con una prueba válida de compra en un distribuidor autorizado de PDP que muestre claramente la fecha de compra.

**■ Recurso exclusivo y exclusiones** • El recurso exclusivo para los reclamos válidos será la reparación, sustitución o devolución del producto. Esta garantía no cubre los defectos causados por accidentes, uso indebido o abusivo del producto, modificaciones, reparaciones o manipulación no autorizadas o incorrectas.

**■ Cómo obtener ayuda** • Los compradores deben ponerse en contacto con el departamento de atención al cliente de PDP al número (800) 331-3844 (EE. UU. y Canadá únicamente) o al número +442036957905 (Reino Unido únicamente), o pueden acceder a support.pdp.com o support.pdp-eu.com. En general, las preguntas se contestan durante el transcurso de las siguientes veinticuatro horas hábiles.

**■ Sus derechos según la ley aplicable** • Esta garantía no afecta los derechos legales de los clientes de acuerdo con las leyes estatales, provinciales o nacionales aplicables que rigen la venta de bienes de consumo.

### PORTUGUÊS GARANTIA LIMITADA

**■ Cobertura e termo** • A PDP assegura que este produto estará livre de defeitos de fabricação durante dois anos a contar da data da compra. Defeitos de fabricação são os defeitos em materiais e/ou fabricação, sujeitos a aprovação final pelo departamento de atendimento ao cliente da PDP. Esta garantia se aplica somente aos compradores originais que tenham um comprovante de compra válido de uma loja autorizada pela PDP no qual conste a data da compra.

**■ Indenização exclusiva e exclusões** • A indenização exclusiva para reclamações válidas será o reparo, substituição ou reembolso do produto. Esta garantia não cobre defeitos causados por acidentes, uso indevido ou abusivo do produto, manuseio, modificações ou reparos não autorizados ou indevidos.

**■ Como obter atendimento** • Os compradores devem entrar em contato com o departamento de atendimento ao cliente da PDP ligando para (800) 331-3844 (somente EUA e Canadá) ou +442036957905 (somente Reino Unido) ou acessando os sites support.pdp.com ou support.pdp-eu.com. As perguntas costumam ser respondidas em até 24 horas (horário comercial).

**■ Seus direitos conforme a lei aplicável** • Esta garantia não afeta os direitos legais dos consumidores conforme as leis estadual, provincial ou nacional referentes à venda de bens de consumo.

### Argentina

AVH  
Deheza 3189, C1429EBC CABA  
Tel. 45450686  
Tel. 66323284 ext. 273  
Email: sac@avh.com.ar  
Página web: www.avh.com.ar

Argentina  
COMPUUNDO S.A.  
Camacua 46 | C.A.B.A. | CP 1406  
Tel. +54 (011) 4632.0096  
Email: cac@compuundo.com.ar  
Página web: www.compuundo.com.ar

Brasil  
HG DIGITAL SERVICE LTDA.  
AVENIDA POMPEIA, 1522  
SÃO PAULO - SP  
CEP 050220-001 - VILA POMPEIA  
Tel. (11) 3868-2658 / 3862-2516  
Fax (11) 3875-1333  
Email: hgdigital@hgdigital.com.br

Chile  
SERVICIO TECNICO NINTENDO CHILE  
LO ECHEVERS 311  
PARQUE INDUSTRIAL, VESPUCCIO OESTE  
QUILICURA  
SANTIAGO, CHILE  
Tel. +562-27147855  
Email: st.nintendochile@jvlat.com

Colombia  
PUNTOS DE SERVICIOS S.A.  
CARRERA 49 # 93-12  
BOGOTÁ, COLOMBIA  
PBX (+57 1) 2567233 2567261 ext 105  
Online: www.puntosdeservicios.com

Perú  
ELAUI E.I.R.L.  
AVENIDA EX OSCAR BENAVIDES 4707  
CALLAO, LIMA  
Tel. (511) 619-7697/619-7698  
Email: gex9@elaui.com  
Online: www.elaui.com.pe

México  
DISTRIBUIDORA GAMEXPRESS  
55 36851100  
JUAN SALVADOR AGRAZ #40,  
PISO 7 (OFICINAS GAMEXPRESS) COL. LOMAS DE SANTA FE,  
CUAJIMALPA 05348, CIUDAD DE MÉXICO.  
Página Web: http://gameexpress.vg/contacto.php

Argentina  
AVH  
Deheza 3189, C1429EBC CABA  
Tel. 45450686  
Tel. 66323284 ext. 273  
Email: sac@avh.com.ar  
Página web: www.avh.com.ar