

Overhead Garage Door Operator

Dominator Tempo & Syncro Instruction Manual

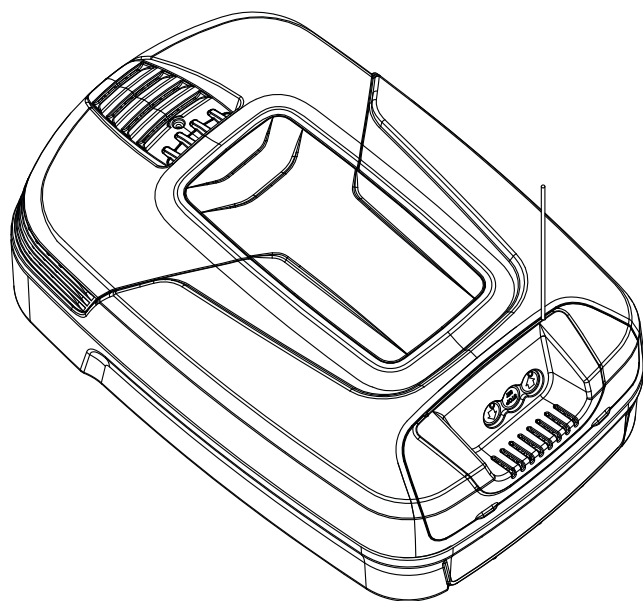

Conforms to:
ANSI/CAN/UL325
Tested to comply
with Part 15 of the
FCC Rules



**DOMINATOR TEMPO ATS-2AM
SECTIONAL DOOR OPENER**

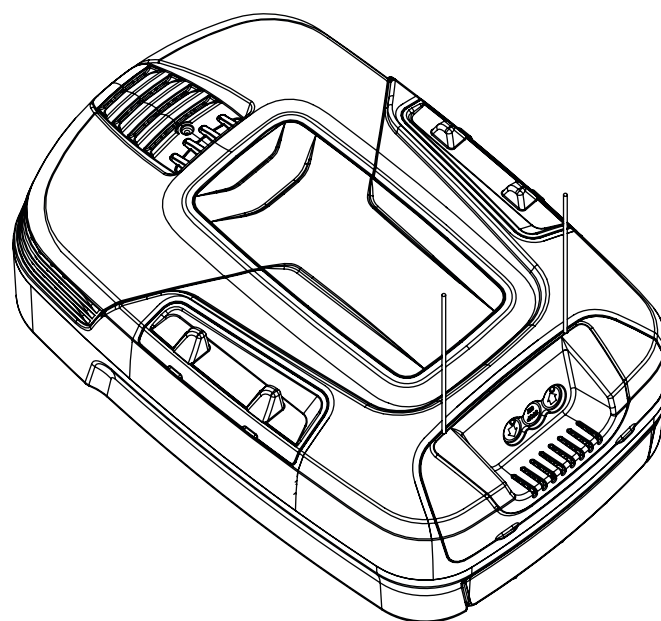

**DOMINATOR SYNCRO ATS-3AM
SMART SECTIONAL DOOR OPENER**

FOR RESIDENTIAL USE ONLY



WARNING!: It is vital for the safety of persons to follow all instructions. Failure to comply with the installation instructions and the safety warnings may result in serious personal injury and/or property and remote control opener damage. Please save these instructions for future reference.



ELECTROCUTION!: To reduce the risk of electric shock, this equipment has a grounding type plug that has a third (grounding) pin. This plug will only fit into a grounding type outlet. If the plug does not fit into the outlet, contact a qualified electrician to install the proper outlet. Do not change the plug in any way. This operator is not equipped for permanent wiring. Contact a qualified electrician to install a suitable receptacle if one is not available.

CONTENTS

Overhead Garage Door Operator

1. Safety Information	4	6.6 Coding Transmitters	15
2. System Specifications	5	6.6.1 Setting Remote Control Transmitter Codes	15
3. Operating controls	6	6.6.2 Install Wireless Wall Mounted Remote Transmitter	16
4. Kit Contents	7	6.6.5 Remotely Coding Remote Control Transmitters	16
5. Operator Safety & Security	8	6.6.3 Erasing All Remote Control Transmitter Codes	16
5.1 Manual Door Operation	8	6.6.4 Vacation Mode	16
5.2 Emergency Evacuations	8	6.7 Battery Backup	17
5.3 Power Failure	8	6.7.1 Connecting the Battery Backup	17
5.4 Re-Engaging the Operator	8	6.7.2 Test the Opener	17
5.5 Security - Inbuilt Locking Facility	8	6.7.3 LED Battery indicator	17
6. Installation Instructions	9	6.8 Accessories	17
6.1 C-Rail Assembly	10	6.9 Auto-Ki Smart Phone Control	18
6.2 Mounting Operator for a Track Type Door	10	7. Operation Instructions	19
6.2.1 Determine Bracket Position	10	7.1 How to Use Your Operator	20
6.2.2 Mounting the Wall Bracket	10	7.1.1 To Operate the opener:	20
6.2.3 Attach the C-Rail to the Wall Bracket	10	7.1.2 Replacing the Battery: 3V Lithium Battery CR2032.	20
6.2.4 Securing the Powerhead Perforated Angle or equivalent	11	7.2 User Operating Controls	21
6.2.6 Mounting Door Bracket	11	7.3. Troubleshooting	22
6.2.7 Attaching the Arms	11	7.4. Service / Warning Indicator	23
6.3 Safety Beam Installation	12	7.4.1 Main Light = Service / Warning Indicator:	23
6.3.1 Safety Infra-Red Beam Kit (P/N 62047)	12	7.4.2 Connecting or Disconnecting Accessories:	23
6.3.2 Assembling the Mounting Bracket	12	8. User Maintenance Instruction	23
6.3.3 PE Assist Alignment	12	8.1 Door Maintenance	23
6.4 Setting Speed and Limits	13	8.2 If You Need a Service Call	23
6.4.1 Set the Limit Positions and adjust drive speed:	13	9. Appendix	24
6.4.2 Clearing the Door Limit Positions	13	A - Status Indication during Operating Mode.	24
6.4.3 Re-profiling the Door	13	B - Adjustment Mode Instructions	25
6.5 Safety Testing & Auto-Close	14	C - Adjusting Force Margins	25
6.5.1 Obstruction Detection Test	14	D - Battery Functions	25
6.5.2 Test the Close Cycle and Safety Reversal	14	E - Setting limits via Transmitter	26
6.5.3 Testing the Open Cycle	14	F - Setting the PET Mode position	27
6.5.4 Test the Manual Door Operation	14	G - Setting up Tilt Door	27
6.5.5 Auto-Close	14		

1. Safety Information



WARNING!

- This operator should be installed in accordance with relevant US and Canada Standards.
- To reduce the risk of injury to persons – Use this operator only with a sectional door. DO NOT install product on J-Type or Single Piece Doors.
- This operator is not suitable for commercial, industrial or common entry applications.
- This operator is a plug in domestic appliance and is designed for indoor use only. It must be installed in a dry position that is protected from the weather.
- Door must have Safety Beams fitted.
- Activate the operator only when the garage door is in full view, free of obstructions and with the operator properly adjusted.
- The network device allows for operation of the door when not in line-of-sight of the door and operator. Therefore the door may operate unexpectedly, therefore do not allow anything to stay in or near the path of the door.
- Watch the moving door and keep people away until the door is completely opened or closed.



ELECTROCUTION:

- Installation and wiring must be in compliance with your local building and electrical codes.
- This operator is not equipped for permanent wiring. Contact a qualified electrician to install a suitable receptacle if one is not available.
- To reduce the risk of electric shock, this equipment has a grounding type plug that has a third (grounding) pin. This plug will only fit into a grounding type outlet. If the plug does not fit into outlet, contact a qualified electrician to install the proper outlet. Do not change the plug in any way.
- If the power cord is damaged, it must be replaced by the manufacturer, its service agent or a similarly qualified person in order to avoid a hazard.
- Connect the power cord only to properly earthed mains. If an extension lead must be used, make sure it is a 3-core lead and approved to 7 amp capacity.
- This unit is not user serviceable. Unplug the power cord before removing the cover. Ensure that the power cord is attached clear of all moving parts. Ignoring these instructions can cause electric shock.

Please read these important safety rules

These safety alert symbols indicate a personal safety or property damage instruction exists. READ THESE INSTRUCTIONS CAREFULLY.

This automatic garage door operator is designed and tested to offer safe service provided it is installed and operated in strict accordance with the following safety rules. Failure to comply with the installation instructions and the safety warnings may result in death, serious personal injury and/or property damage.



CAUTION:

- If your garage has no pedestrian entrance door, an emergency access device should be installed. This accessory allows manual operation of the garage door from outside in case of power failure.
- Keep the garage door balanced. Sticking or binding doors must be repaired. Garage doors, door springs, brackets and their hardware are under extreme tension and can cause serious personal injury. Do not attempt any garage door adjustment. Do not use if repair or adjustment is needed. Call for professional garage door service.
- Position the Garage Door Operator so that the power plug is accessible when inserted into the power outlet.
- Install the wall transmitter in a location where the garage door is visible, but out of the reach of children at a height of at least 5 feet (1.53m).
- To avoid serious personal injury from entanglement, remove all unnecessary ropes or chains and disable any equipment such as locks which are not needed for powered operation.
- Do not wear rings, watches or loose clothing while installing or servicing a garage door operator.
- Ensure ladder is the correct type for the job and is on flat ground. We recommend the user has 3 points of contact while on ladder.
- Activate the operator only when the garage door is in full view, free of obstructions and with the operator properly adjusted.
- The operator is not intended for use by young children or infirm persons without supervision.
- Keep transmitters away from children.
- Do not allow children to play with door controls.

2. System Specifications

Factory Default Settings

	Default	Maximum
Maximum motor run time	1 Minute	-
Courtesy light time	180 secs	-
Obstruction force margin	0.7 amp	1.5 amp
Auto close time	0 seconds	-

Technical Specifications

Model	SYNCRO ATS-3AMB	SYNCRO ATS-3AM	TEMPO ATS-2AMB	TEMPO ATS-2AM
Input Voltage	120Vac / 60Hz	120Vac / 60Hz	120Vac / 60Hz	120Vac / 60Hz
Current (Max)	2.0A	2.0A	2.0A	2.0A
Transformer secondary output Voltage	24Vac	24Vac	24Vac	24Vac
Motor type	24Vdc geared motor with permanent magnet	24Vdc geared motor with permanent magnet	24Vdc geared motor with permanent magnet	24Vdc geared motor with permanent magnet
Shuttle travel distance in the C-Rail	9.19ft (2.8m) approximately (standard)	9.19ft (2.8m) approximately (standard)	9.19ft (2.8m) approximately (standard)	9.19ft (2.8m) approximately (standard)
Maximum shuttle travel distance in the C-Rail	16.4ft (5m) (with extended C-Rail)	16.4ft (5m) (with extended C-Rail)	16.4ft (5m) (with extended C-Rail)	16.4ft (5m) (with extended C-Rail)
Peak Short Term Pulling Force	1000N	1000N	1000N	1000N
Maximum door hanging weight	520lbs (236kg)	520lbs (236kg)	440lbs (200kg)	440lbs (200kg)
Receiver type	UHF Multifrequency FM-Receiver	UHF Multifrequency FM-Receiver	UHF Multifrequency FM-Receiver	UHF Multifrequency FM-Receiver
Receiver code storage capacity	14 X 4 button transmitter codes	14 X 4 button transmitter codes	14 X 4 button transmitter codes	14 X 4 button transmitter codes
Transmitter frequency	433.47MHz; 433.92MHz; 434.37MHz	433.47MHz; 433.92MHz; 434.37MHz	433.47MHz; 433.92MHz; 434.37MHz	433.47MHz; 433.92MHz; 434.37MHz
Coding type	TrioCode128™	TrioCode128™	TrioCode128™	TrioCode128™
Number of code combinations	Over 4.29 billion random codes	Over 4.29 billion random codes	Over 4.29 billion random codes	Over 4.29 billion random codes
Code generation	Nonlinear encryption algorithm	Nonlinear encryption algorithm	Nonlinear encryption algorithm	Nonlinear encryption algorithm
Remote control battery	CR2032 3 Volts	CR2032 3 Volts	CR2032 3 Volts	CR2032 3 Volts
Courtesy light	2 LED Modules	2 LED Modules	2 LED Modules	2 LED Modules
Control board fuse	10A (slow blow)	10A (slow blow)	10A (slow blow)	10A (slow blow)
Battery backup	2 x 12PCA 1.3 - 12V1.3 AH Batteries	Battery compatible, (requires optional Battery Backup kit)	2 x 12PCA 1.3 - 12V1.3 AH Batteries	Battery compatible, (requires optional Battery Backup kit)
Network connectivity	Network ready, Smart hub already installed	Network ready, Smart hub already installed	Network compatible, (requires optional Smart Phone Control Kit)	Network compatible, (requires optional Smart Phone Control Kit)

NOTE: Intermittent operations may occur in areas which experience very strong winds. The strong wind puts extra pressure on the door and tracks which may in turn trigger the safety obstruction detection system intermittently.



3. Operating controls

Button	Function
1. DOWN ARROW (Blue)	Closes the door
2. DOWN ARROW LED (Blue)	Illuminates when the door is closed and flashes when the door is obstructed on close or stopped.
3. STOP (Red)	Stops the door
4. UP ARROW (Green)	Opens the door
5. UP ARROW LED (Green)	Illuminates when the door is open and flashes when the door is open with the auto-close timer running, obstructed on opening or stopped.
6. MODE (Yellow)	Enables Load Diagnostics Mode
7. MODE STATUS LED (Yellow)	Illuminates when in Diagnostics Mode
8. BATTERY STATUS LED (Yellow)	Illuminates when battery is charged and flashes when battery is charging, in use or battery failed. Battery function not available with ATS-2 model.
9. REMOTE CONTROL STATUS LED (Red)	Flashes on remote lockout and flickers on remote control activity
10. ADJUSTMENT LED (Yellow)	Flashes a certain number of times depending on the parameter being changed.
11. NETWORK LED (ATS-3AMB Only)	Is a dual colour LED. Illuminates purple when hot spot active, blue when connected to cloud and red when in production mode. Flashes different colour depending on the activity.

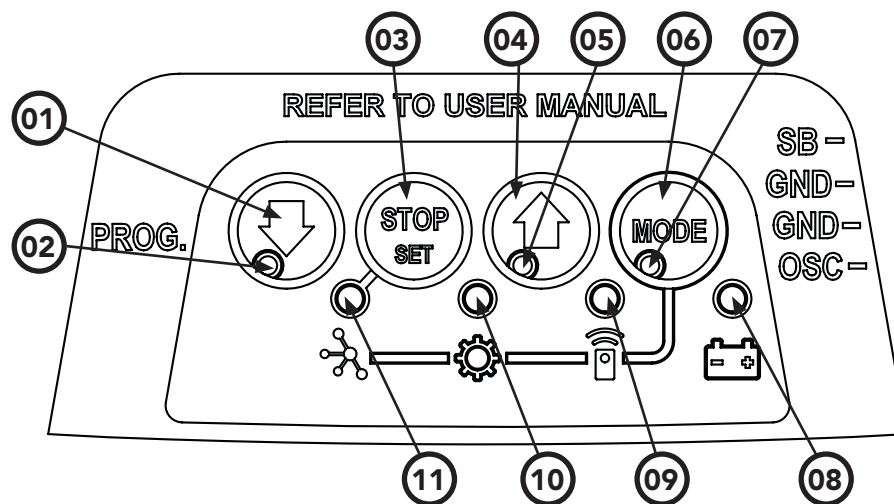

Fig.3.1

4. Kit Contents

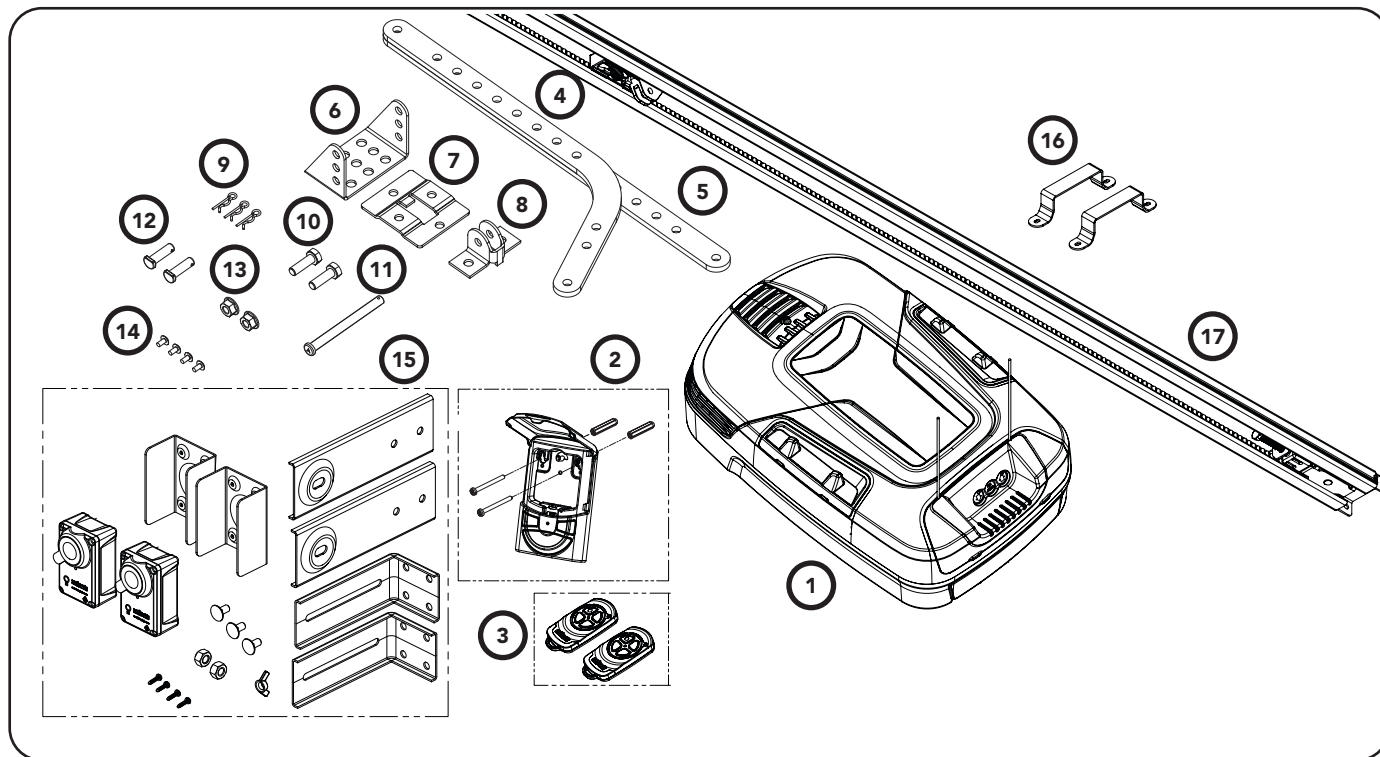

Fig.4.1

- | | |
|-------------------------------------|--|
| 1. 1 x ATS drive unit | 8. 1 x Door bracket |
| 2. 1 x Wall mount transmitter kit | 9. 3 x Pin Snap SSP 8 ZNU 31080 |
| 3. 2 x Transmitters and batteries | 10. 2 x Hex Head screw M8x25 |
| 4. 1 x Bent arm door attachment | 11. 1 x Pin 0890 |
| 5. 1 x Straight arm door attachment | 12. 2 x Clevis Pin 0829 |
| 6. 1 x Wall bracket TS01 | 13. 2 x Hex Serration flange nut M8 |
| 7. 1 x Door bracket Locator | 14. 4 x Hex flange screw taptite 'S' M4 x 10 |
| | 15. 1 x Wired Safety Beam kit |

- PLUS
- 16. 2 x Track Bracket
 - 17. 1 x Pre-Assembled C-Rail

NOTE: Chain/belt in one piece rail has been tensioned by the factory. Do not adjust the tension of the chain/timing belt.

IMPORTANT NOTE: If modification to the track length required, adjustment must be made only from power head end.

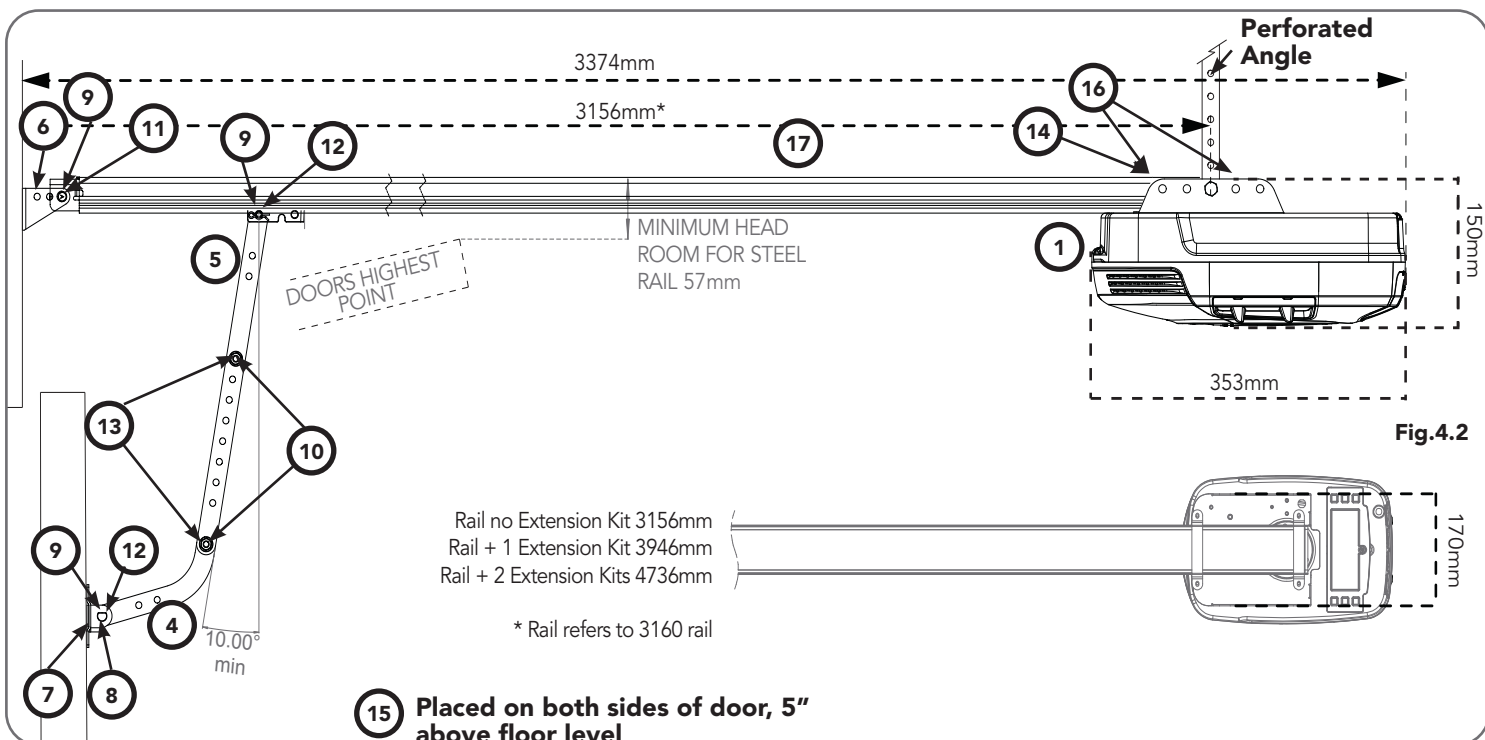

5. Operator Safety & Security

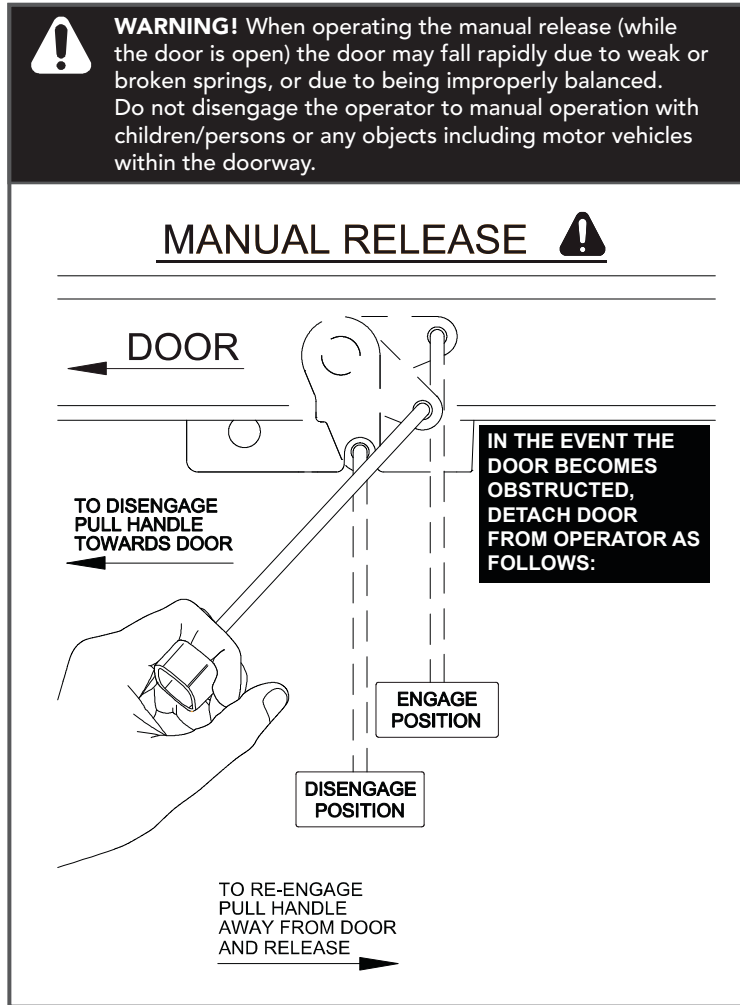

Fig. 5.1

5.1 Manual Door Operation

To disengage the operator from the door (preferably with the door in the closed position), pull down on the string handle on an angle towards the door (Fig 5.1). This will allow you to manually open or close the door.



CAUTION: Do not use the string handle as a mechanism to open the door. Failure to comply may cause serious injury.

To re-engage the operator pull the string handle away from the door - see Re-Engaging the Operator.

5.2 Emergency Evacuations

In emergencies the garage door can be disengaged from the operator, via the manual release cord and the door opened manually. The manual release cord should be a maximum of 1.8m from the ground. The cord can be adjusted for special considerations.

5.3 Power Failure

When there is a power failure, the operator will be unable to automatically open or close your garage door. To use your door whilst there is no power you will need to disengage the operator and use the door manually – see 5.1 Manual Door Operation.

5.4 Re-Engaging the Operator

When the door has been disengaged from the opener, the shuttle assembly, attached to the manual release cord, can move up and down the chain. Re-engage the opener (Fig 5.1) (preferably with the door open to waist height) and then press the programmed transmitter button, the motor will run until the shuttle assembly engages the chain index on the chain, you will hear it click into place. Then the door will operate as normal.

5.5 Security - Inbuilt Locking Facility

DO NOT lock your door when your operator is engaged as it has inbuilt locking facility. With the opener engaged your door will be locked whether the power is on or off.



CAUTION: When the operator is manually disengaged, the door is no longer locked. To lock the door manually, re-engage the operator after the door is closed.

6. Installation Instructions

IMPORTANT INSTALLATION INSTRUCTIONS

WARNING! TO REDUCE THE RISK OF SEVERE INJURY OR DEATH:

- (1) READ AND FOLLOW ALL INSTALLATION INSTRUCTIONS.
- (2) INSTALL ONLY ON A PROPERLY OPERATING AND BALANCED GARAGE DOOR. AN IMPROPERLY BALANCED DOOR HAS THE POTENTIAL TO INFLICT SEVERE INJURY. HAVE A QUALIFIED SERVICE PERSON MAKE REPAIRS TO CABLES, SPRING ASSEMBLIES, AND OTHER HARDWARE BEFORE INSTALLING THE OPENER.
- (3) REMOVE ALL PULL ROPES AND REMOVE, OR MAKE INOPERATIVE ALL LOCKS CONNECTED TO THE GARAGE DOOR BEFORE INSTALLING OPENER.
- (4) WHERE POSSIBLE, INSTALL THE DOOR OPENER 7 FEET OR MORE ABOVE THE FLOOR. FOR PRODUCTS HAVING AN EMERGENCY RELEASE, MOUNT THE EMERGENCY RELEASE WITHIN REACH BUT AT LEAST 6 FEET ABOVE THE FLOOR AND AVOIDING CONTACT WITH VEHICLES TO AVOID ACCIDENTAL RELEASE.
- (5) DO NOT CONNECT THE OPENER TO SOURCE OF POWER UNTIL INSTRUCTED TO DO SO.
- (6) LOCATE THE CONTROL BUTTON:
 - (I) WITHIN SIGHT OF DOOR,
 - (II) AT A MINIMUM HEIGHT OF 5 FEET ABOVE FLOORS, LANDINGS, STEPS OR ANY OTHER ADJACENT WALKING SURFACE SO SMALL CHILDREN ARE NOT ABLE TO REACH IT, AND
 - (III) AWAY FROM ALL MOVING PARTS OF THE DOOR.
- (7) INSTALL THE ENTRAPMENT WARNING LABEL NEXT TO THE CONTROL BUTTON IN A PROMINENT LOCATION. INSTALL THE EMERGENCY RELEASE MARKING. ATTACH THE MARKING ON OR NEXT TO THE EMERGENCY RELEASE.
- (8) AFTER INSTALLING THE OPENER, THE DOOR MUST REVERSE WITHIN 2 SECONDS WHEN IT CONTACTS A 1 1/2 -INCH HIGH OBJECT (OR A 2 BY 4 BOARD LAID FLAT) ON THE FLOOR.
- (9) FOR PRODUCTS HAVING A MANUAL RELEASE, INSTRUCT THE END USER ON THE OPERATION OF THE MANUAL RELEASE.

6.1 C-Rail Assembly

6.1.1 Installing the C-Rail

- Remove the Opener from the box.
- Locate and insert the shaft of drive unit (1) into the C-Rail's sprocket as shown in Fig 6.1.
- Fix the two track brackets (16) with four (4) M4 x 8 screws (14) supplied in accessory pack (Fig 6.1.2).
- Place drive unit back in packing box for protection.

ELECTROCUTION! This operator is not equipped for permanent wiring. Contact a qualified electrician to install a suitable receptacle if one is not available.

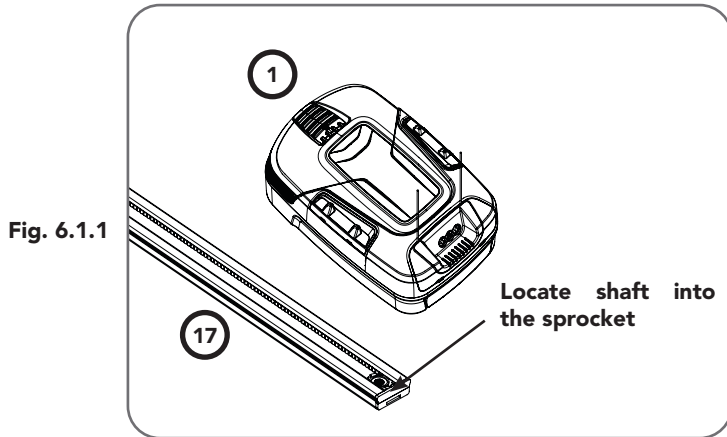

Fig. 6.1.1

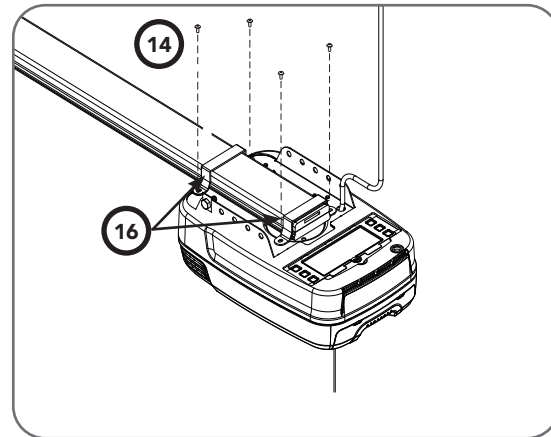

Fig.6.1.2

6.2 Mounting Operator for a Track Type Door

WARNING! To reduce the risk of injury to persons - Use this operator only with a sectional door.

6.2.1 Determine Bracket Position

- Determine the centre of the door and mark this point with a line on the wall above.
- Raise the door and find the highest point of travel of the first (top) door panel.
- Using step ladder and a level, transfer this height to the wall above the door and mark a line 2.36" (60mm) above it, across the centre line (Fig.6.2.1).

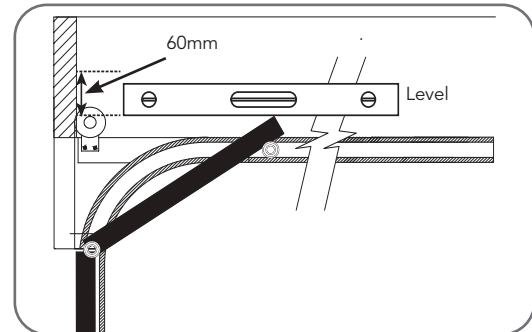

Fig.6.2.1

6.2.2 Mounting the Wall Bracket

- Draw two lines extending 0.846" (21.5mm) from each side of the centre point (Fig.6.2.2).
- Centre the wall bracket (6) over the intersection of these two lines. Mark centres for at least two holes and ensure it is into a solid mounting point.
- Drill holes in the wall with an appropriate bit.
- Secure to the wall using:
 - IF CONCRETE OR BRICK:
8mm (5/6") loxins/dynabolts.
 - IF TIMBER:
wood screw #20 or similar (minimum 1.97" 50mm long) (Fig.6.2.2).

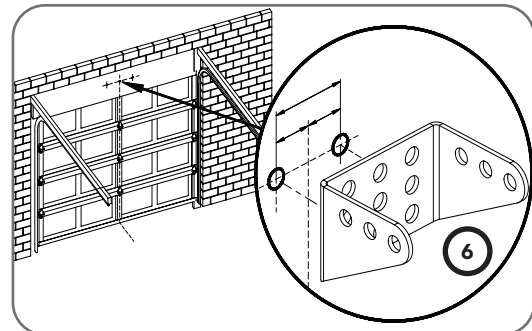

Fig.6.2.2

WARNING!: Make sure concrete, brick wall or timber lintels are solid and sound so as to form a secure mounting platform.

6.2.3 Attach the C-Rail to the Wall Bracket

- Leave the drive unit in its packing box on the floor for protection and lift the other end of the C-Rail.
- Attach the C-Rail assembly (17) to the wall bracket (6) with the 3.54" (90mm) long pin (11) and secure with the supplied pin snap (9) (Fig.6.2.3).

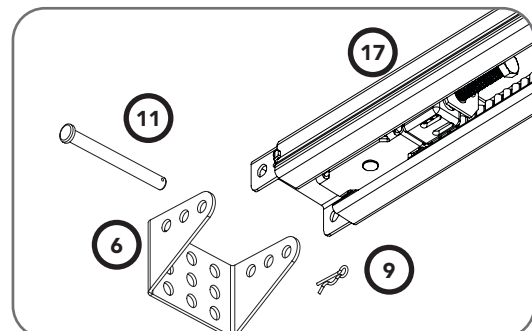
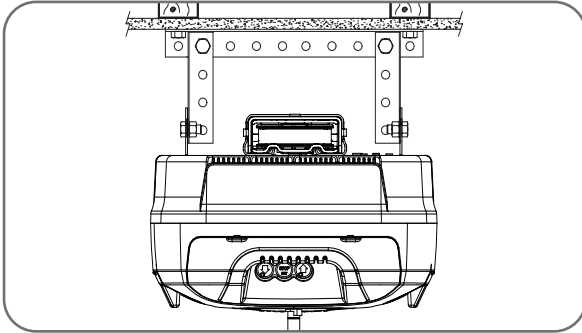

Fig.6.2.3

6.2 Mounting Operator for a Track Type Door

Fig.6.2.4



Ceiling Beams that run towards the door requires:

- 1 x perforated L shape metal strip and
- 2 x shorter perforate L shape metal drop down strips.

Fig.6.2.5

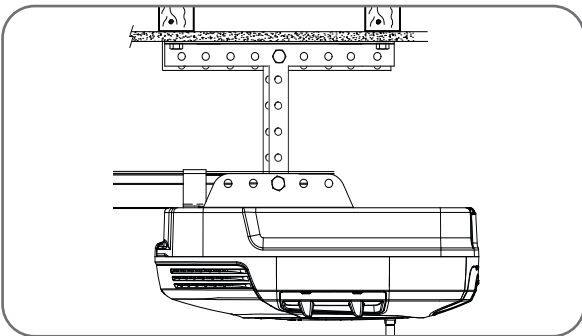

Ceiling Beams that run parallel to the door requires:

- 2 x perforated L shape metal strips and
- 2 x shorter perforate L shape metal drop down strips.

6.2.6 Mounting Door Bracket

- a. The door bracket locator (7) is placed over the door bracket (8), on the door's centre line one-third down the top panel and mounted using M6 or equivalent screws (not supplied) (Fig 6.2.6).
- b. STEEL DOORS ONLY: Bracket can be welded in place.

NOTE: As various types of doors exist, if in doubt about the strength of the door, reinforcement may need to be added to the frame of the door panel where necessary. Damage to the door panel may occur if the bracket is installed incorrectly on a panel with insufficient strength. The door operator warranty does not cover damage caused by the operator to the door and/or door panel.

Fig.6.2.6

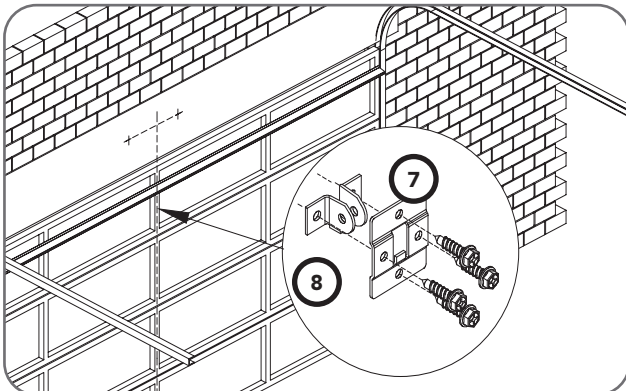

6.2.7 Attaching the Arms

- a. Assemble the bent arm (4) (connecting to the door) to the right side of the straight arm (5) with bolts (10) and nuts (13) supplied in the accessory pack. Connect the straight arm (5) to the shuttle with a clevis pin (12) and a pin snap (9). Always use both bent and straight arms (Fig 6.2.7).
- b. Connect the assembled arm to the bracket with clevis pin (12) and pin snap (9). The angle "A" must be more than 10°.

6.2.4 Securing the Powerhead Perforated Angle or equivalent

- a. Measure across the ceiling from the centre point 3155mm (+/- 50mm) to find a supporting beam.
- b. Create a perforated angle which best suits your site. Use a hack saw to cut the L shape metal strips. Secure the perforated angle to a supporting beam using diagrams shown below (Fig.6.2.4 & Fig.6.2.5).
- c. Raise the drive unit to the ceiling mounted perforated angle and secure with M8x20mm screws and nuts (not supplied). Strips should not extend more than 0.708" 18mm below centre of drive unit mounting holes.
- d. To prevent moisture on the C-rail running into the powerhead it is recommended a strip of silicon sealant is placed across the top of the C-rail just before the opener.



WARNING! The operator must be securely fastened to a structural support of the garage. Failure to fasten the operator correctly may lead to operator failure causing serious personal injury and/or property damage.



ELECTROCUTION! This operator is not equipped for permanent wiring. Contact a qualified electrician to install a suitable receptacle if one is not available.



WARNING! connecting the bent arm other way around may damage the door.

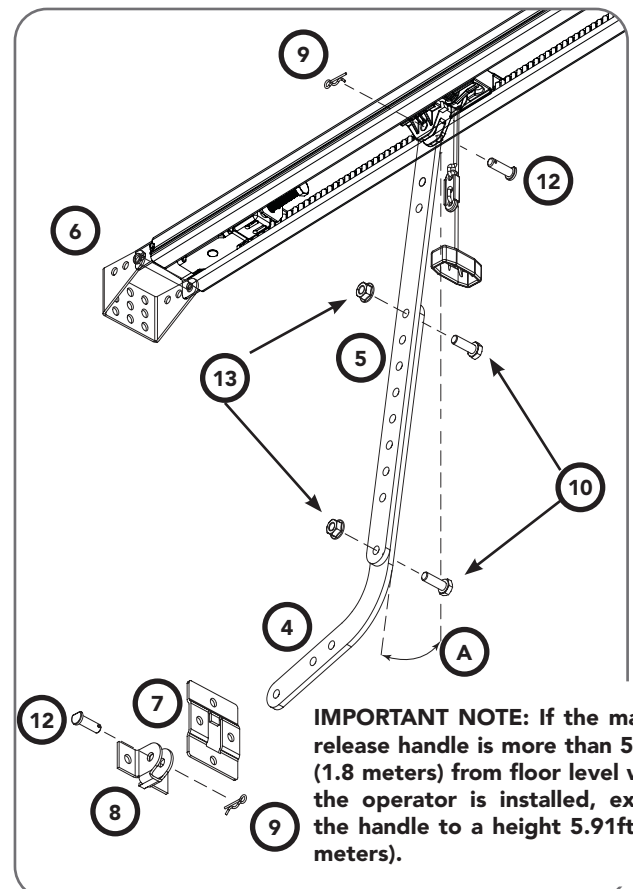

Fig.6.2.7

IMPORTANT NOTE: If the manual release handle is more than 5.91ft (1.8 meters) from floor level when the operator is installed, extend the handle to a height 5.91ft (1.8 meters).

6.3 Safety Beam Installation

IMPORTANT NOTE: The Safety Beam must be installed and connected before the travel limits are set.

6.3.1 Safety Infra-Red Beam Kit (P/N 62047)

A Safety Beam extends across the door opening. This Safety Beam is designed to detect an obstruction while the door is closing and to send a signal to the door operator to reverse or stop the door movement. **Install the Safety Beam indoor only.**

6.3.2 Assembling the Mounting Bracket

- Place the round screw (3) through the Bracket (5). Attach the Safety Beam Transmitter (TX) using four (4) M3 x 5 Taptite screws (4) (Fig. 6.3.1).
- Connect the mounting bracket (2) to the Bracket (5) using the wing nut (8) onto the round screw (3). Secure the adjustment bracket (6) to the mounting bracket (2) using two (2) screws (3) and nuts (7).
- Repeat steps (a) and (b) to assemble the Safety Beam Receiver (RX).
- Locate the Safety Beam in a strategic location in the door opening. **We recommend** that the sensor is placed no higher than 6" and no lower than 5" above the floor level. The mounting surface should be rigid.

6.3.3 PE Assist Alignment

- Wire the PE Beams as per Wiring Diagram (Fig. 6.3.2).
 - After the beams are installed the beam alignment feature of the opener can be used.
 - Turn power on to the opener.
 - Align the safety beams by moving them per Fig 6.3.3 and using the main light as a guide:
 - bright = aligned
 - dull = not aligned or blocked
- When the beams are aligned, continue with Setting Limits.

WARNING: When the Safety Beam is fitted, the doorway must be clear of all obstructions and persons at all times. Incorrect location of the safety beams may not give safety protection at all times. Check to make sure that the height of the beam gives maximum protection.

WARNING: Connect the Safety Beam as per diagram in Fig 6.3.2. Tampering with the Safety Beam could result in serious personal injury and/or property damage and will void the warranty.

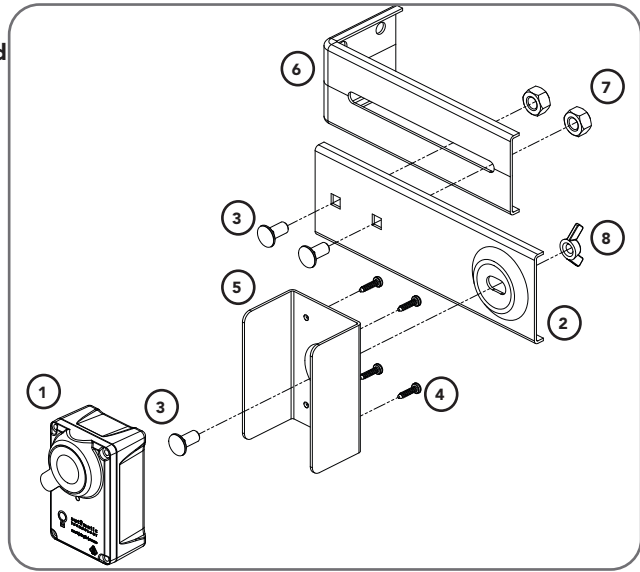

Fig.6.3.1

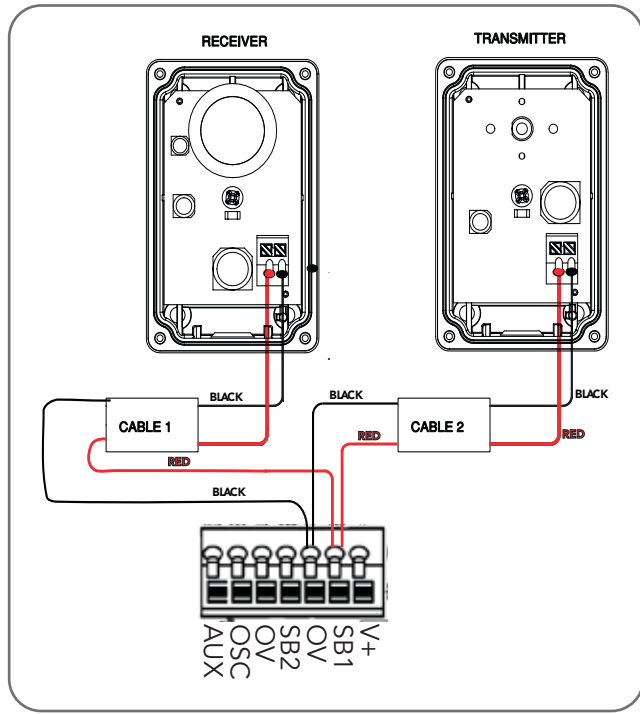

Fig.6.3.2

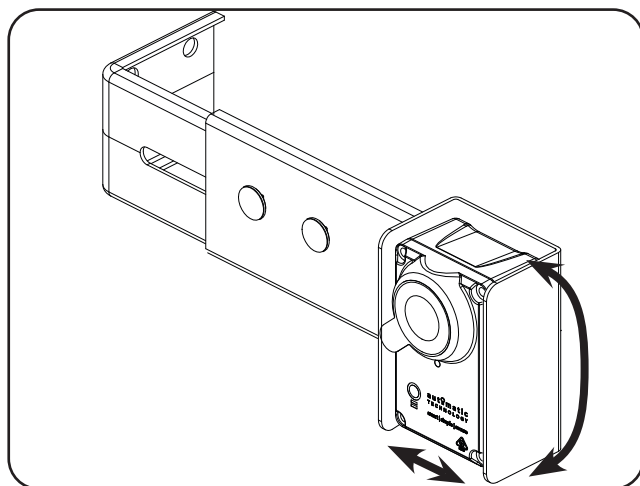

Fig 6.3.3

6.4 Setting Speed and Limits

6.4.1 Set the Limit Positions and adjust drive speed:

The Limit Positions can vary due to site conditions, such as uneven ground. When setting the Close limit, ensure the position is when the door makes first contact with the ground. Alternatively for the Open limit the position should be at the height of the garage opening.

NOTE: The drive speed is set to the fastest setting by default. This may not be suitable for larger doors or for single piece doors. For tilt doors (J-Type only), please refer to Appendix G for initial setup.

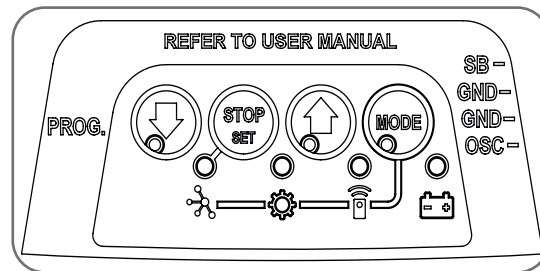



Fig.6.4.1



Door Opener Speed Mode	STATUS	MAIN LIGHT
Fast (Default)	On	3 Flash
Medium	On	2 Flashes
Slow	On	1 Flashes

a. Switch power on and the BLUE LED on the CLOSE button 

will start to flash and the GEAR  LED is lit to indicate that the opener is ready to set the Close travel limit (**Fig 6.4.1**).



b. Press either the CLOSE  or OPEN button  to move the door to the halfway point.

CLOSE limit:

- Press and hold the CLOSE button  to start closing the door, taking note of the speed the door moves.
- If the close speed is not suitable, to make a change, press and hold the CLOSE button and by pressing the STOP / SET button on the opener it will cycle through all three speed modes as shown in table.
- Once at the desired speed, release the CLOSE button.
- To set the close limit,  the door by making single presses of the CLOSE button  to the desired position. We recommend the CLOSE limit position being the first point of contact of the rubber strip (at the bottom of the door) with the ground.



WARNING! In setting the close limit position, do not force the door into the floor with excessive force, as this can interfere with the ease of operation of the manual release mechanism.

- If the door overshoots, press the OPEN button  to move the door in the OPEN direction.
- When the door is at the desired CLOSE position, press the STOP / SET button  on the opener, the GREEN LED on the OPEN button  will now flash.

NOTE: If unhappy with the speed or travel limit setting, restart this procedure by resetting the door limit positions as per below first.

6.4.2 Clearing the Door Limit Positions





Limit positions can be deleted by:

- Press the MODE button repetitively until the GEAR  LED is lit.
- Press and hold the MODE button for 10 secs, let the MODE button go when the main light stops flashing.
- The close LED will flash continuously to indicate limits have been cleared.

NOTE: If no action is taken within 30 seconds, the opener will return to normal operating mode and restore the original settings.

- Follow from CLOSE limit: above to set new limit positions.

OPEN limit:

- Press and hold the OPEN button  to start opening the door, taking note of the speed the door moves.
- If the open speed is not suitable, to make a change, press and hold the OPEN button and by pressing the STOP / SET button on the opener it will cycle through all three speed modes as shown in table.
- Once at the desired speed, release the OPEN button.
- Continue inching the door to the desired position.
- To set the open limit  the door by making single presses of the OPEN button  to the desired position. We recommend the OPEN limit position being the height of the garage opening.
- If the door overshoots, press the CLOSE button  to move the door in the CLOSE direction.



WARNING! The door will automatically close, open and close again after the next step. Ensure that nothing is in the door's path.



- When the door is at the desired OPEN position, press the STOP / SET button The door will now automatically close and open to calculate the safety obstruction settings.



tip Refer to Appendix B & C for adjustments to margins.

6.4.3 Re-profiling the Door

Re-profiling is a simplified way of re-learning the travel characteristic of a previously setup Limit Switch travel installation. Re-profiling can be used when the travel characteristics of the door change due to mechanical adjustments etc. To initiate a re-profile:

- Limits must be set.
- Press the MODE button repetitively until the GEAR  LED is lit.
- Press and hold the CLOSE button  for two seconds, the door will open and close by itself to record profile.

6.5 Safety Testing & Auto-Close

6.5.1 Obstruction Detection Test

Check the Safety Beam photoelectric sensor is operating after the installation.

- Place an obstruction (white vertical surface 6 in. high by 12 in. wide) in the center of the opening, perpendicular to the plane of the door when in the closed position as per **Fig 6.5.1**.
- Press the CLOSE button  or the transmitter button to close the door. The photoelectric sensor shall sense an obstruction as described above. The door will not move more than an inch (2.54cm), and the opener lights will flash.

6.5.2 Test the Close Cycle and Safety Reversal

- Press the OPEN button  or transmitter button to open the door. (If the door starts closing, press the transmitter button to stop the door, then press transmitter again to open).
- Place an object approximately 1-1/2"(38mm) high (or a 2"x 4" board laid flat) on the floor directly under the door, **Fig 6.5.2**.
- Press the transmitter button to close door.
- The door should strike the object and re-open.
- Remove the timber.

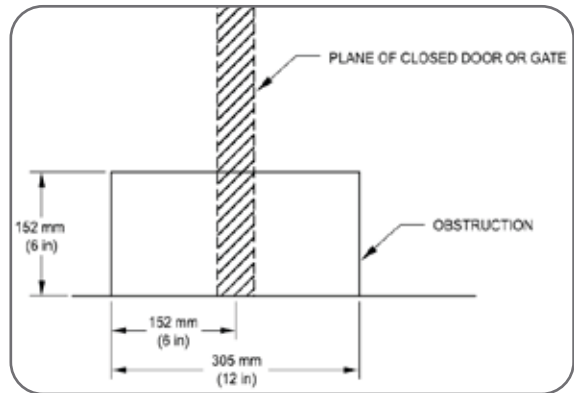

Fig.6.5.1

CAUTION: Take care when testing the safety obstruction force. Excessive force may cause serious personal injury and/or property damage can result from failure to follow this warning.

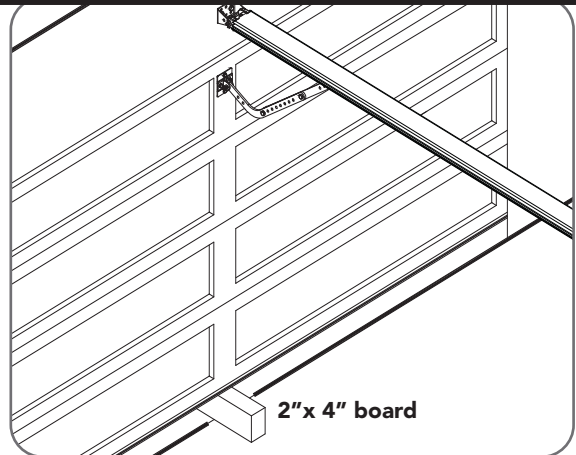



Fig.6.5.2

IMPORTANT WARNING! If the door is closing and is unable to re-open when obstructed, discontinue use. DO NOT use a door with faulty obstruction sensing. Repair fault and re-test before using.

6.5.3 Testing the Open Cycle

- Press the CLOSE button  or transmitter button to close the door.
- Press the transmitter button again to open the door.
- When the door reaches approximately half way, firmly grab the door's bottom rail - the door should stop.

If the door does not reverse readily when closing, or stop when opening, put the door into manual by pulling down on the manual release string to disengage the motor and contact your dealer for support.

6.5.4 Test the Manual Door Operation





Periodically disengage the opener and manually operate the door. The door must be smooth to operate by hand. The force required on the bottom rail should not exceed 44lbs (20kg).

6.5.5 Auto-Close

Auto-Close mode is a function that automatically closes the door after a pre-set time. Safety beams must be installed in order to run the Auto-Close function. There are two types of Auto-Close available:

- Standard auto-close - the door will Auto-Close after a programmed time. In this mode the timer starts to countdown as soon as the door is fully open. This function is useful in case the safety beam does not get triggered.
- Safety Beam triggered auto-close - the door will auto-close after a programmed time. In this mode the timer starts counting down only when the safety beam is triggered. ie car leaving the garage.

To enable the Auto-Close function:

- Press the MODE button repetitively until the GEAR  LED starts flashing.
- Press the OPEN button  until the GEAR  LED flashes:
 - two (2) times to get to PE auto-close or
 - three (3) times to get to standard auto-close.
- Press STOP / SET button to enter parameter.
- The default setting for Auto-Close is OFF. Press the OPEN button  to move through options and the light's brightness will change accordingly.
- Press STOP / SET button to save the parameter's new value or press MODE to leave the value unchanged.

WARNING! If the door fails these tests, put the opener into manual mode, only operate the door by hand and call for service.

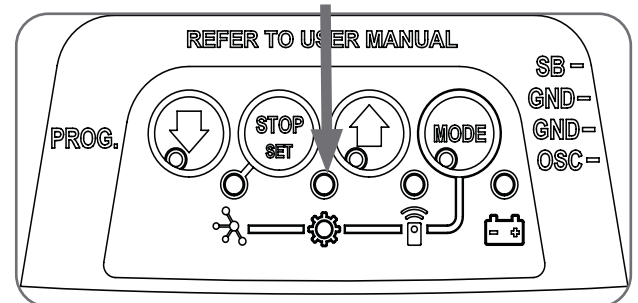

WARNING! It is compulsory to have Safety Beams installed when using Auto-Close mode.

Parameter		Value options = Indicated by brightness of main light (DEFAULT parameter underlined)					
Name	Flashes	1	2	3	4	5	6
PE AUTO-CLOSE	2	<u>OFF</u>	15sec	30sec	60sec	90sec	-
AUTO-CLOSE	3	<u>OFF</u>	15sec	30sec	60sec	90sec	120sec

6.6 Coding Transmitters

6.6.1 Setting Remote Control Transmitter Codes

The opener can only be operated from 4-button remote control transmitters that have been programmed into its memory. Up to 64 codes can be stored in the memory.

- Press the MODE button repetitively until the TRANSMIT LED is lit.
- Press and HOLD the button/s indicated in the **Fig 6.6.1** to set the required transmitter function. The Main light will start to flash rapidly.
- Press one of the four (4) buttons on the remote control transmitter (**Fig 6.6.2**) until the main light starts to flash rapidly, then release transmitter button.
- Press the remote control transmitter button again until the main light stops flashing rapidly.
- Release both buttons. The remote control transmitter button is now coded, press to test.

NOTE: Refer to the Light indicator table for the details of the transmitter status.

MAIN LIGHT	TRANSMITTER STATUS
ON	Button added
OFF	Button removed
2 FLASHES, then OFF	Remote control deleted
4 FLASHES, then OFF	Memory full



TRANSMITTER FUNCTION	BUTTON		
			
Open / Stop / Close	HOLD		
PET (Pedestrian) Mode		HOLD	
Open			HOLD
Light	HOLD	HOLD	
Vacation Mode	HOLD		HOLD

Fig.6.6.1

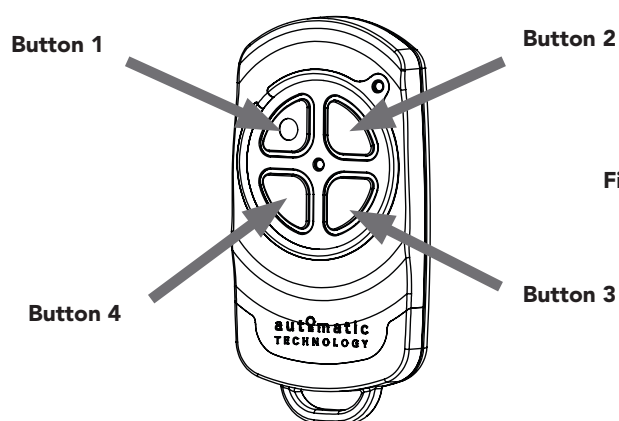

Fig.6.6.2

TRANSMITTERS COMPLIANCE STATEMENT

TRANSMITTERS COMPLY WITH ALL UNITED STATES AND CANADIAN LEGAL REQUIREMENTS AS OF THE DATE OF MANUFACTURE. TO COMPLY WITH **FCC PART 15** AND OR **RSS 210 INNOVATION, SCIENCE AND ECONOMIC DEVELOPMENT CANADA** RULES, ADJUSTMENT OR MODIFICATIONS OF THIS RECEIVER AND / OR TRANSMITTER ARE PROHIBITED, EXCEPT FOR CHANGING THE CODE SETTING OR REPLACING THE BATTERY. THERE ARE NO OTHER USER SERVICEABLE PARTS. TESTED TO COMPLY WITH FCC STANDARD FOR HOME OR OFFICE USE. OPERATION IS SUBJECT TO THE FOLLOWING TWO CONDITIONS:

- (1) THIS DEVICE MAY NOT CAUSE HARMFUL INTERFERENCE, AND
- (2) THIS DEVICE MUST ACCEPT ANY INTERFERENCE RECEIVED, INCLUDING INTERFERENCE THAT MAY CAUSE UNDESIRE OPERATION.

NOTE: THIS EQUIPMENT HAS BEEN TESTED AND FOUND TO COMPLY WITH THE LIMITS FOR A CLASS B DIGITAL DEVICE, PURSUANT TO PART 15 OF THE FCC RULES. THESE LIMITS ARE DESIGNED TO PROVIDE REASONABLE PROTECTION AGAINST HARMFUL INTERFERENCE IN A RESIDENTIAL INSTALLATION. THIS EQUIPMENT GENERATES, USES AND CAN RADIATE RADIO FREQUENCY ENERGY AND, IF NOT INSTALLED AND USED IN ACCORDANCE WITH THE INSTRUCTIONS, MAY CAUSE HARMFUL INTERFERENCE TO RADIO COMMUNICATIONS. HOWEVER, THERE IS NO GUARANTEE THAT INTERFERENCE WILL NOT OCCUR IN A PARTICULAR INSTALLATION. IF THIS EQUIPMENT DOES CAUSE HARMFUL INTERFERENCE TO RADIO OR TELEVISION RECEPTION, WHICH CAN BE DETERMINED BY TURNING THE EQUIPMENT OFF AND ON, THE USER IS ENCOURAGED TO TRY TO CORRECT THE INTERFERENCE BY ONE OR MORE OF THE FOLLOWING MEASURES:

- REORIENT OR RELOCATE THE RECEIVING ANTENNA
- INCREASE THE SEPARATION BETWEEN THE EQUIPMENT AND RECEIVER
- CONNECT THE EQUIPMENT INTO AN OUTLET ON A CIRCUIT DIFFERENT FROM THAT TO WHICH THE RECEIVER IS CONNECTED
- CONSULT YOUR LOCAL DEALER OR AN EXPERIENCED RADIO/TV TECHNICIAN FOR HELP.

6.6 Coding Transmitters

6.6.2 Install Wireless Wall Mounted Remote Transmitter

- Turn the wall switch over and pull the tab to commission the battery. (Fig 6.6.2)
- Store the transmitter code as per instructions in Section 6.6.1. Test the transmitter button.
- Mount the transmitter using parts provided in a convenient location, yet out of reach of children and at least 5 feet off the ground. (Fig 6.6.3)
- Make sure the door is visible from this location.

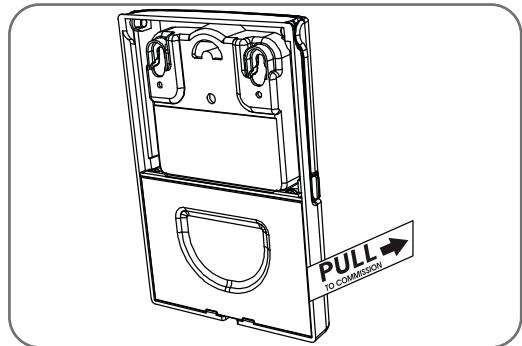

Fig.6.6.2

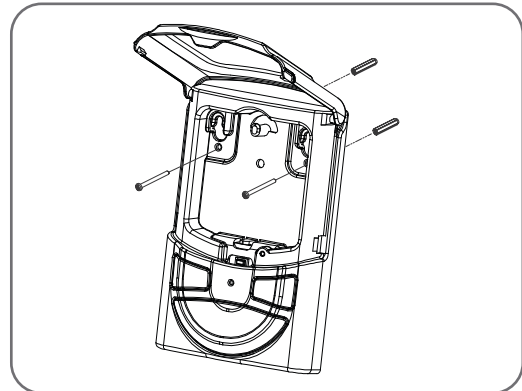

Fig.6.6.3

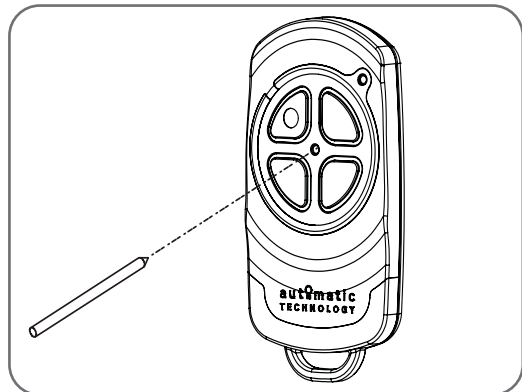

Fig.6.6.4

WARNING! The manufacturer is not responsible for any radio or TV interference caused by unauthorized modifications to this equipment. Such modifications could void the user's authority to operate the equipment.

IMPORTANT WARNING

LOCATE THE WALL MOUNTED REMOTE CONTROL:

- (1) WITHIN SIGHT OF DOOR.
- (2) AT MINIMUM HEIGHT OF 5 FEET ABOVE FLOORS, LANDINGS, STEPS OR OTHER ADJACENT WALKING SURFACE SO SHALL CHILDREN ARE NOT ABLE TO REACH IT, AND
- (3) AWAY FROM MOVING PARTS OF THE DOOR.
- (4) PLACE THE ATTACHED ENTRAPMENT WARNING LABEL ON WALL NEXT TO WALL MOUNTED TRANSMITTER. USE AN ADDITIONAL MECHANICAL MEANS (PLATE, BOARD, ETC.), WHICH CAN SECURE THE LABELS TO SURFACES TO WHICH THE ADHESIVE WILL NOT ADHERE.
- (5) DO NOT REMOVE OR PAINT OVER THIS LABEL.

6.6.3 Erasing All Remote Control Transmitter Codes

- Press the MODE button repetitively until the TRANSMIT  LED is lit.
- Press and hold the MODE button for 10 secs, let the MODE button go when the main light stops flashing.
- Follow steps a - e in Storing the Transmitter Code to code new transmitters.

6.6.4 Vacation Mode

- To turn on Vacation mode and lock out all remotes, press the button on the remote programmed with Vacation Mode.
- To turn off Vacation Mode, press the transmitter button programmed to vacation mode to turn off.

6.6.5 Remotely Coding Remote Control Transmitters

Using this method transmitters can be coded without access to the opener's control panel as long as a pre-coded transmitter is available.

- Take any pre-coded transmitter. Press the button for the function to be duplicated and release.
- Using a small needle / pen, press and hold firmly for two seconds the middle button, through the Coding Hole (Fig 6.6.4).
- Within ten (10) seconds take the additional transmitter you wish to code. Hold the new transmitter's button for two seconds, pause for two seconds, hold again for two seconds and then release.
- Wait for ten (10) seconds and then press the new transmitter's button to test.

6.7 Battery Backup

6.7.1 Connecting the Battery Backup

(Available with ATS-3AM model, optional for ATS-2AM)

a. Remove the screw and open the cover to the batteries. (Fig.6.7.1)

! WARNING! After Step (c) the opener may become active (even when power is off). This is a result of a residual charge in the batteries.

- b. Connect the coupling blue harness (2A) to the red plus terminal (A+) on Battery (A), then connect coupling blue harness (2B) to the black minus terminal (B-) on Battery (B).
- c. Connect the coupling red wire (4A) to the red plus terminal (A+) on Battery (A), then connect coupling black wire (4B) to the black minus terminal (B-) on Battery (B).
- d. Close the cover, securing with screw and reconnect power.

NOTE: Batteries may take up to 24 hours to charge fully after initial installation.

6.7.2 Test the Opener

- a. Press either the OPEN or CLOSE button to test the battery backup installation.
- b. Whilst door is in motion, disconnect mains power. The door should continue to operate as normal.
- c. Press either the OPEN or CLOSE button to activate the door. Whilst door is in motion, reconnect power. The door should complete the cycle as normal.

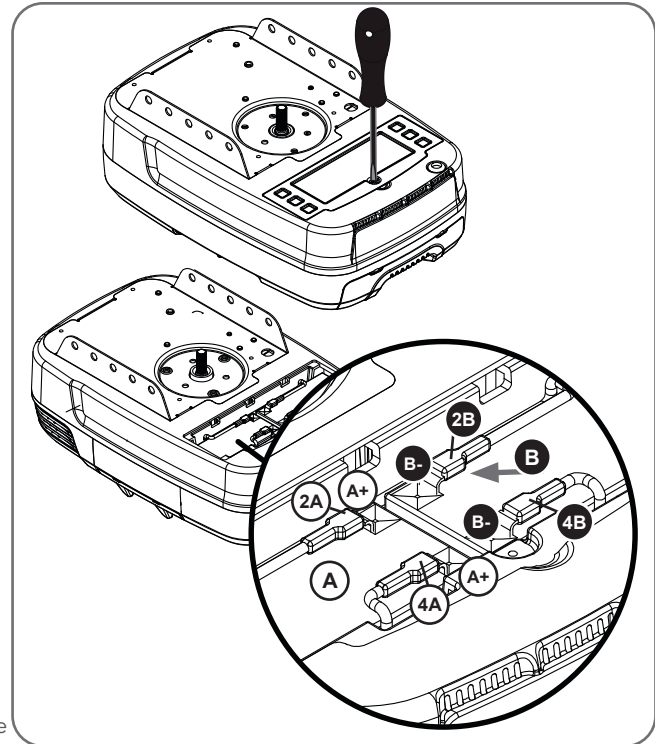

Fig.6.7.1

Status	Opener Battery LED
Battery not used	Stays off
Battery charging	Flashing 1 sec on and 1 sec off
Battery charged	Solid on
Battery in use	Flashing 0.2 sec on and 1.8 sec off
Battery failed	Flashing 0.2 sec on and 0.2 sec off

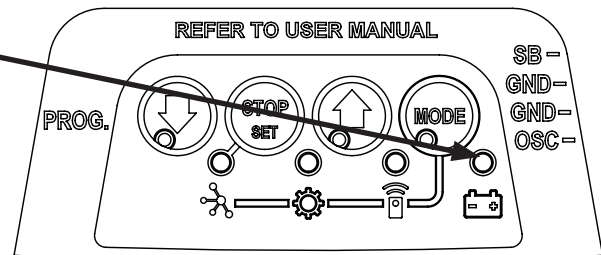

Fig.6.7.2

6.8 Accessories

6.8.1 Terminal Block

Wired accessory items can be connected to the terminal block J4 such as Safety Beams (Fig. 6.8.1).

Terminal connections from top down are as follows:

1. SB (Safety Beam input, mandatory);
2. GND (Common ground for accessories and Safety Beam);
3. GND (Common ground)
4. OSC (Open/Stop/Close trigger)

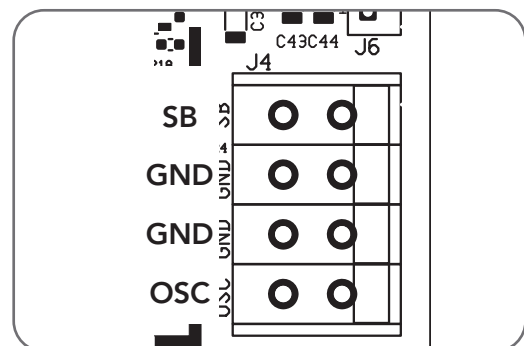

Fig.6.8.1



6.9 Auto-Ki Smart Phone Control (ATS-3AMB Only)

CLASS B DEVICE CAN ICES-3 (B)/NMB-3 (B)

This equipment has been tested and found to comply with the limits for a Class B digital device, pursuant to Part 15 of the FCC Rules. These limits are designed to provide reasonable protection against harmful interference in a residential installation. This equipment generates, uses and can radiate radio frequency energy and, if not installed and used in accordance with the instructions, may cause harmful interference to radio communications. However, there is no guarantee that interference will not occur in a particular installation. If this equipment does cause harmful interference to radio or television reception, which can be determined by turning the equipment off and on, the user is encouraged to try to correct the interference by one or more of the following measures:

- Reorient or relocate the receiving antenna
- Increase the separation between the equipment and receiver
- Connect the equipment into an outlet on a circuit different from that to which the receiver is connected.
- Consult the dealer or experienced radio/TV technician for help.

To comply with FCC/IC RF exposure limits for general population / uncontrolled exposure, the antenna(s) used for this transmitter must be installed to provide a separation distance of at least 7.87in (20cm) from all persons and must not be co-located or operating in conjunction with any other antenna or transmitter.

Changes or modifications not expressly approved by the party responsible for compliance could void the user's authority to operate the equipment.
This network device allows for unattended operation of the door when not in line-of-sight of the door opener.

The door may operate unexpectedly, therefore do not allow anything to stay in or near the path of the door. When the door is not operating automatically, watch the door when it is moving and keep people away until the door is completely opened or closed. **Contact with the moving door can cause serious personal injury or damage to property.**

Your opener must be fitted with SAFETY BEAMS. Safety Beams detect any obstructions in the door's path and override automatic operation if one presents. These must be installed as in accordance with UL 325 and CSA C222.2 No 247.

This is in addition to regular professional servicing, and monthly obstruction tests as detailed in your opener's Owners Manual.

The compliance to FCC radiation exposure limits for an uncontrolled environment, and a minimum of 20cm separation between antenna and body. This device complies with part 15 of the FCC Rules. Operation is subject to the following two conditions: (1) This device may not cause harmful interference, and (2) this device must accept any interference received, including interference that may cause undesired operation.

tip Ensure limits are set prior to connecting to Wifi.

6.9.1 Connecting to Wifi

The Smart Phone Control works via your home's WiFi network. Initial set up involves linking your phone app, smart hub and opener to your home network.

- Download the ATA App.
- Ensure the WiFi router is within range of the opener.
- On the opener press the MODE button repetitively until the

NETWORK  LED is lit. (Fig 6.9.1)

- Press and hold the OPEN button on the opener for 4 seconds. The

NETWORK  LED will turn purple when Hot Spot is Active.

- Go to phone settings, then WiFi and select (ATA000000).
- Open App and tap on Start.
- Select setup a new Smart Hub
- When Smart hub hotspot connection appears, select OK got it.
- Ensure WiFi network = (ATA000000) then select connect to hub.
- The opener main light and a red NETWORK  LED will start to flash.
- Press STOP / SET button on the opener.
- Name your smart hub on the app and select SAVE.

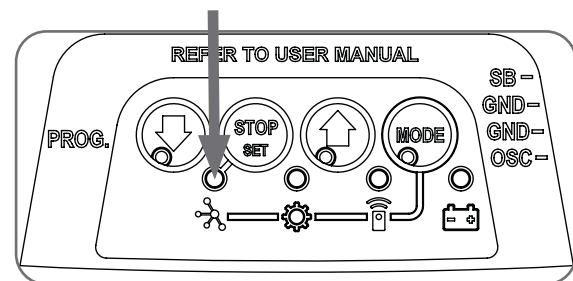



Fig.6.9.1

- Set the time zone and SAVE.
- Create an admin user and select "OK got it".
- Fill in name and password and select CREATE.
- Fill in email and security question or select skip this step and select SAVE.
- Select the push notification and select SAVE.
- Select and connect to WiFi. Choose your home WiFi and fill in password and select connect.
- The NETWORK  LED will change to solid blue.
- Now you can test the app.

7. Operation Instructions

IMPORTANT SAFETY INSTRUCTIONS

WARNING! TO REDUCE THE RISK OF SEVERE INJURY OR DEATH:

- (1) **READ AND FOLLOW ALL INSTALLATION INSTRUCTIONS.**
- (2) NEVER LET CHILDREN OPERATE OR PLAY WITH DOOR CONTROLS. KEEP THE REMOTE CONTROL AWAY FROM CHILDREN.
- (3) ALWAYS KEEP THE MOVING DOOR IN SIGHT AND AWAY FROM PEOPLE AND OBJECTS UNTIL IT IS COMPLETELY CLOSED. **NO ONE SHOULD CROSS THE PATH OF THE MOVING DOOR.**
- (4) **NEVER GO UNDER A STOPPED, PARTIALLY OPEN DOOR.**
- (5) TEST DOOR OPENER MONTHLY. THE GARAGE DOOR **MUST** REVERSE ON CONTACT WITH A 1-1/2-INCH HIGH OBJECT (OR A 2 BY 4 BOARD LAID FLAT) ON THE FLOOR. AFTER ADJUSTING EITHER THE FORCE OR THE LIMIT OF TRAVEL, RETEST THE DOOR OPENER. FAILURE TO ADJUST THE OPENER PROPERLY INCREASES THE RISK OF SEVERE INJURY OR DEATH.
- (6) FOR PRODUCTS HAVING AN EMERGENCY RELEASE, WHEN POSSIBLE, USE THE EMERGENCY RELEASE ONLY WHEN THE DOOR IS CLOSED. USE CAUTION WHEN USING THIS RELEASE WITH THE DOOR OPEN. WEAK OR BROKEN SPRINGS ARE CAPABLE OF INCREASING THE RATE OF DOOR CLOSURE AND INCREASING THE RISK OF SEVERE INJURY OR DEATH.
- (7) **KEEP GARAGE DOORS PROPERLY BALANCED.** SEE OWNER'S MANUAL. AN IMPROPERLY BALANCED DOOR INCREASES THE RISK OF SEVERE INJURY OR DEATH. HAVE A QUALIFIED SERVICE PERSON MAKE REPAIRS TO CABLES, SPRING ASSEMBLIES, AND OTHER HARDWARE.
- (8) EXCEPT FOR MODEL AM800, THIS OPERATOR SYSTEM IS EQUIPPED WITH AN UNATTENDED OPERATION FEATURE. THE DOOR COULD MOVE UNEXPECTEDLY. **NO ONE SHOULD CROSS THE PATH OF THE MOVING DOOR.**
- (9) **SAVE THESE INSTRUCTIONS.**

7.1 How to Use Your Operator

For maximum efficiency of your operator, your garage door must be in good operating condition.

An annual service of your garage door by door professional is recommended.

Fig.7.1.1

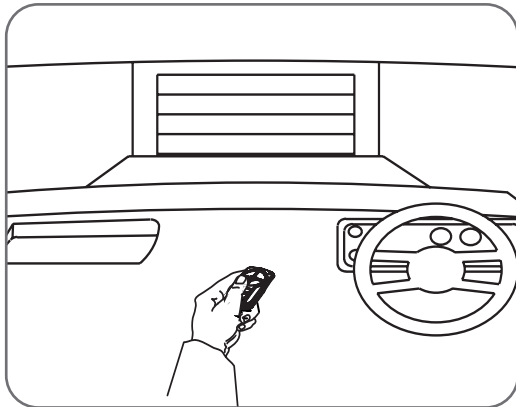

CAUTION: Activate the operator only when the door is in full view, free of obstructions and with the operator properly adjusted. No one should enter or leave the garage while the door is in motion. Do not allow children to play near the door.



WARNING! This operator has a grounding type plug and there are no user serviceable parts inside this operator.

Fig.7.1.2

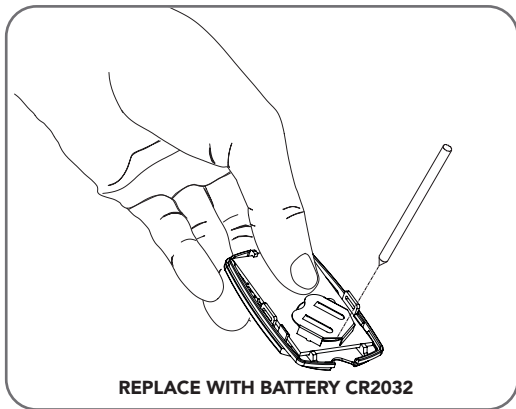

7.1.1 To Operate the opener:

- Press the programmed transmitter button until your door begins to move (usually 2 seconds). Make sure you can see the door when you use the transmitter (**Fig 7.1.1**).
- If you are in a vehicle you should aim the transmitter through your windscreen as shown.
- Check that the door is fully open or closed before you drive in or away.
- If you press the transmitter whilst the door is moving the door will stop. The next press of the transmitter will move the door in the opposite direction.

7.1.2 Replacing the Battery: 3V Lithium Battery CR2032.

- To test the battery is working, press and hold a transmitter button. Check Light Status table to determine if battery needs replacing

Light Status	Battery Status
Solid	OK
Flashing	Requires replacement
No light	Requires replacement

- Remove screw from back of cover.
- Use screw driver to separate the transmitter casing to expose circuit board.
- Use a non-metallic object (e.g. pen) to remove the battery. (**Fig. 7.1.2**).

7.2 User Operating Controls

Button	Function
1. DOWN ARROW (Blue)	Closes the door
2. DOWN ARROW LED (Blue)	Illuminates when the door is closed and flashes when the door is obstructed on close or stopped.
3. STOP (Red)	Stops the door
4. UP ARROW (Green)	Opens the door
5. UP ARROW LED (Green)	Illuminates when the door is open and flashes when the door is open with the auto-close timer running, obstructed on opening or stopped.
6. MODE (Yellow)	Enables Load Diagnostics Mode
7. MODE STATUS LED (Yellow)	Illuminates when in Diagnostics Mode
8. BATTERY STATUS LED (Yellow)	Illuminates when battery is charged and flashes when battery is charging, in use or battery failed. Battery function not available with ATS-2 model.
9. REMOTE CONTROL STATUS LED (Red)	Flashes on remote lockout and flickers on remote control activity
10. ADJUSTMENT LED (Yellow)	Flashes a certain number of times depending on the parameter being changed.
11. NETWORK LED (ATS-3AMB Only)	Is a dual colour LED. Illuminates purple when hot spot active, blue when connected to cloud and red when in production mode. Flashes different colour depending on the activity.

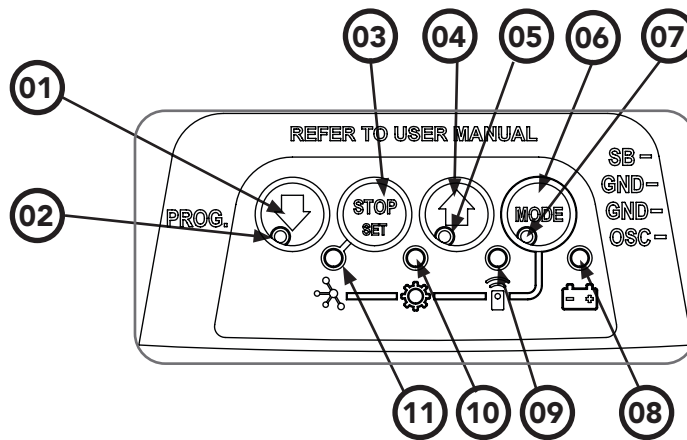

7.3. Troubleshooting

Symptom	Possible cause	Remedy
The opener does not work from the transmitter	Garage door in poor condition e.g. springs may be broken	Check the door's operation
	The opener does not have power	Plug a device of similar voltage (e.g. a hairdryer) into the power point and check that it is OK
	The battery in the transmitter is flat	Replace the battery
	The opener has turned on "Vacation Mode"	Turn off "Vacation Mode" (Section 6.6.4)
	The transmitter button is not programmed to operate the door.	Code in the transmitter
One transmitter works but the other/s do not	Faulty transmitter	Replace transmitter
	Flat battery	Replace battery
The chain / belt moves but the door remains stationary	The opener is disengaged	Re-engage the opener
Motor is running but chain / belt is not moving	Damage motor assembly	Contact your dealer for support.
The transmitter range varies or is restricted	Variations are normal depending on conditions e.g. temperature or external interference	Make sure you can see the door when you use the transmitter.
	The battery life is exhausted	Check the battery status by pressing a button (flashing or no light, battery need changing)
	Position of the transmitter in the motor vehicle	Aim the transmitter through the windscreen.
The Courtesy light does not work	LED has failed	Change LED.
The door reverses for no apparent reason	This may occur occasionally from environmental conditions such as areas that are windy, dusty or have extreme temperature changes.	Ensure the door runs smoothly before increasing the force pressure.
	If Safety beams are installed they may be partially obstructed.	Ensure the beam path is not obstructed. Check the Alignment.
Door will not close	Safety Beam not working	To access safety close mode, hold the transmitter button to close for 6 seconds and continue to hold while the door closes. Check Safety Beam
	Safety Beam battery flat	
Auto Close not working	Safety Beam or wiring faulty	Repair Safety Beam or replace wiring. Re-align optics. See Safety Beam instructions.
The door stops or moves very slowly under battery (Optional Battery Back Up Accessory)	The batteries may have little or no charge	Connect mains power and leave the batteries to charge. The batteries may take 24 hours to reach their maximum charge capacity.
The CLOSE (Blue) LED is flashing	Limits are not set	Set Up Limits (Section 6.4).



7.4. Service / Warning Indicator

7.4.1 Main Light = Service / Warning Indicator:

Requirements for a service and user warnings are indicated after operation by the main light repeatable flashing OFF a number of times followed by a pause. The below table identifies the issues and remedies.

Flashes	Issue	Remedy
1	Normal operation (door is fully open)	
2	PE is preventing door from moving	Clear away any obstructions. Test Door. If unable to move the door and suspect beam is faulty, enter Safety Beam Emergency Close by pressing and holding a pre-coded button on transmitter for more than five seconds and the door will start closing.
3	NOT AVAILABLE	
4	Wireless PE battery is low	Change PE Battery
5	NOT AVAILABLE	
6	Maintenance is due after pre-set number of cycles.	Contact dealer to arrange service.
7	Standby battery is faulty	Contact (800) 934 9892 within America for assistance
8	Door was obstructed	Clear away any obstructions and test door opens/closes correctly. (If door is damaged, contact your door professional)
9	Motor overloaded or stalled	Check the doors operation by disengaging the motor and ensuring the door runs smoothly. If necessary make door adjustments or contact your door professional.
10	Unit running on battery power	Main light will flash (3) three times at the start of the cycle to indicate opener is running from battery backup. Check power supply.

7.4.2 Connecting or Disconnecting Accessories:

When disconnecting or reconnecting accessory base station modules (Auto-Lock) press the MODE button repetitively until the GEAR LED is on, then press the STOP / SET button until the main courtesy light stops flashing.

8. User Maintenance Instruction



WARNING! Run the Safety Testing procedures **MONTHLY** in Section 10 to ensure garage door is fit for use.



WARNING! Failure to maintain your garage door may void the warranty on your garage door operator.



CAUTION: Frequently examine the installation, in particular cables, springs and mountings, for signs of wear, damage or imbalance.

DO NOT USE if repair or adjustment is needed since a fault in the installation or an incorrectly balanced door may cause injury.

Adjustments should only be carried out by experienced persons, as this function can be dangerous if not performed under strict safety procedures.

8.1 Door Maintenance

A poorly maintained door could cause fatal / serious injuries or damage to property.

- Frequently examine the door, particularly the cables, springs and mountings for signs of wear, damage or imbalance. **DO NOT USE** if repair or adjustment is needed since a fault in the installation or an incorrectly balanced door may cause injury.
- Fasteners: Check all screws, nuts and bolts to ensure they are secure.
- Spring Tension: It is natural for springs to lose tension. Should the door become hard to operate or completely inoperative, contact a door professional.
- Guide Tracks: Clean the internal sections of the guide tracks every 3 - 6 months with a cloth dampened with mineral turps or methylated spirits.

8.2 If You Need a Service Call

If the opener needs a service please call the dealer who installed the garage door opener (their contact details are usually on a sticker on the back of your garage door).

BEFORE CALLING you should have the following information to assist in providing the appropriate service:

- Has anything happened since the opener last operated OK, e.g. a storm, a jolt to the door etc.?
- What is the current light status on the opener?
- Manually disengage the door (Section 5).
How easy is it to manually open and close the door?
- What model is the opener? (Model no. information is located at the rear of the opener)
- Who installed the opener? (Dealer details should be on a sticker on the back of your garage door)
- When was it installed? (If known)





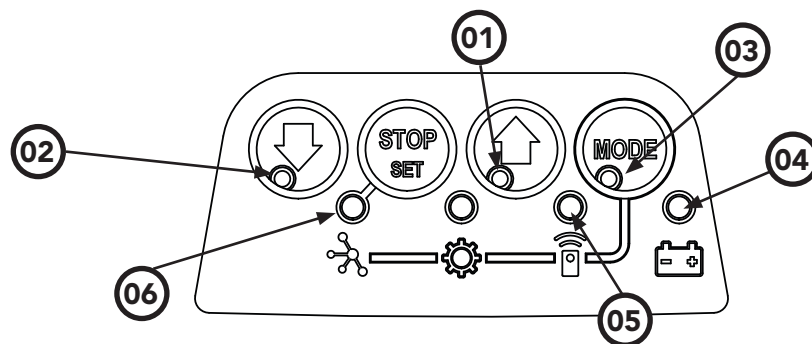

9. Appendix

A - Status Indication during Operating Mode.

LEDs	Light Status					Description
	BLUE	GREEN	YELLOW	RED	PURPLE	
DOOR OPEN (2) AND CLOSED (1) LEDS		solid				Open
		flashing				Open with Autoclose timer running
		flashing				Opening / Obstructed on Open
	solid					Closed
	flashing					Closing / Obstructed on Close
	flashing	flashing				Stopped
	solid	solid				Partial Open
MODE LED (3)			flashing			Load Diagnostics mode
BATTERY LED (4)			off			Battery not used / not fitted
			solid			Battery charged
			flashing			Battery charging, when connected to power, without power battery in use (holding STOP for 10s will shutdown)
			rapid flashing			Battery failed
REMOTE CONTROL STATUS LED (5)				flashing		Remote lockout
				rapid flashing		Remote Control Activity
NETWORK LED (6) (ATS-3AMB Only)	1 flash then pause				solid	Hot Spot Active
	2 flashes then pause					Connecting to Wi-Fi
	solid					Connected to Server
	rapid flashing					Connected to Cloud
	alternate			flashing		Interrupts Hub communications with opener
				alternate		Requires confirmation from user
						Rebooting



B - Adjustment Mode Instructions

- Press the MODE button repetitively until the GEAR  LED starts flashing
- Referring to the table below, select the desired parameter using the OPEN  and CLOSE  buttons and observing the number of flashes on the GEAR  LED. The selected parameter's value is indicated by the main light's brightness.
- Press STOP / SET button to start editing the parameter's value. The TRANSMIT  LED will turn on when editing is active.
- Use the OPEN  and CLOSE  buttons to step through the available options. The light's brightness will change accordingly.
- Press STOP / SET button to save the parameter's new value or press MODE to leave the value unchanged.
- Continue from a. above to select another parameter or press MODE to exit adjustment mode.





Parameter		Value options = Indicated by brightness of main light (DEFAULT parameter underlined)									
Name	Flashes	1	2	3	4	5	6	7	8	9	10
MARGIN	1	<u>0.7A</u>	0.9A	1.2A	1.5A	2.0A	-	-	-	-	-
PE AUTO-CLOSE	2	<u>OFF</u>	15sec	30sec	60sec	90sec	-	-	-	-	-
AUTO-CLOSE	3	<u>OFF</u>	15sec	30sec	60sec	90sec	120sec	-	-	-	-
LIGHT TIMER	4	30sec	60sec	90sec	120sec	<u>180sec</u>	240sec	-	-	-	-

C - Adjusting Force Margins

Adjusting Safety Obstruction Force

The Safety Obstruction Force is calculated automatically during setup. Adjusting this is normally only necessitated by environmental conditions such as windy or dusty areas, and areas with extreme temperature changes.

To Increase / Decrease Force Pressure

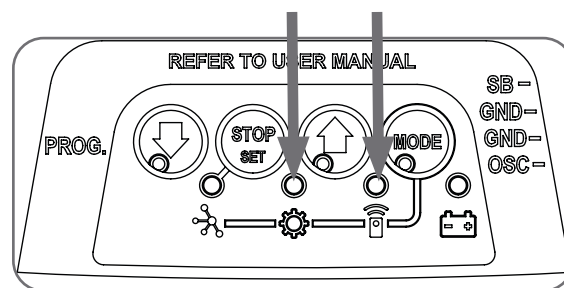

- Press the MODE button repetitively until the GEAR  LED is flashing.
- The LED will start flashing with one flash every second.
- Press the STOP / STEP button and the MODE button LED and the TRANSMIT  LED will be lit and the GEAR  LED will flash once every second.
- By pressing the OPEN button  will increase the force pressure and CLOSE button  will decrease the force - Main light will dim or brighten as the pressure is decreased or increased.
- Press STOP / SET button to save the new value. (Refer to Appendix B for margin settings)
- Test the force again as per Testing Close Cycle and Testing Open Cycle.





D - Battery Functions

- Holding the STOP button for 10secs when running from battery backup will shut the PCB down so as to reduce battery current consumption to a minimum.
- Holding the STOP button for 4secs when a battery is fitted and running from mains power will cause the controller to test the battery state to determine if it is disconnected / open circuit, missing, faulty or ready.

E - Setting limits via Transmitter

- a. Switch power on and the BLUE LED on the CLOSE button  will start to flash to indicate that the opener is ready to set the Close travel limit
- b. Press the MODE button repetitively until the TRANSMIT  LED is lit.
- c. Press and HOLD the CLOSE button  to set the Open / Stop / Close function. The Main light will start to flash rapidly.
- d. Press and hold button 1 on the transmitter, then release transmitter button.
- e. Press and hold button 1 on the remote control button again until the main light stops flashing rapidly.
- f. Release both buttons. The transmitter button is now coded, press to test and observe the speed of the door through a full cycle.
- g. The drive speed is set to the fastest setting by default. This may not be suitable for larger doors or for single piece doors:

CLOSE limit:

- (i) Using the programmed transmitter, press and hold the button 4 to close. To inch the door, single presses of the button 4 will move the door to desired limit.
- (ii) While inching (to CLOSE) to set the close speed, press and hold button 4 on the remote and by pressing the SET button 2 the opener will cycle through all three speed modes as shown in table.
- (iii) Once at the desired speed, release the remote button 4.
- (iv) Continue inching the door to the desired position. We recommend the CLOSE limit position being the first point of contact of the rubber strip (at the bottom of the door) with the ground.
- (v) If the door overshoots, press the OPEN button 1 on the remote to move the door in the OPEN direction.
- (vi) When the door is at the desired CLOSE position,  the SET button 2, the GREEN LED on the OPEN button  will now flash.

Button 1
(inch Open)

Button 2 (Set)

Button 4
(inch Close)

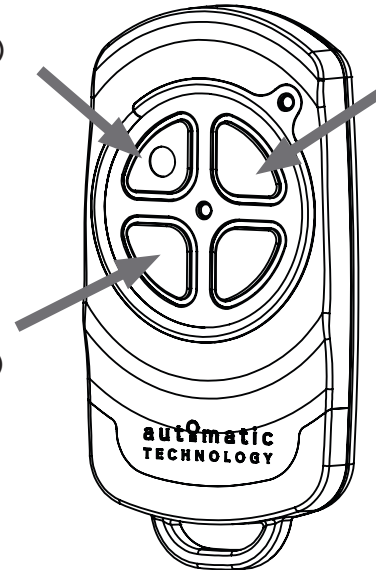

OPEN limit:

- (i) Using the programmed transmitter, press and hold the button 1 to open. To inch the door, single presses of the button 1 will move the door to desired limit.
- (ii) While inching (to OPEN) to set the open speed, press and hold button 1 on the remote and by pressing the SET button 2 the opener will cycle through all three speed modes as shown in table.
- (iii) Once at the desired speed, release the remote button 1.
- (iv) Continue inching the door to the desired position. We recommend the OPEN limit position being the height of the garage opening





WARNING! The door will automatically close, open and close again after the next step. Ensure that nothing is in the door's path.

- (v) If the door overshoots, press the CLOSE button 4 on the remote to move the door in the CLOSE direction.
- (vi) When the door is at the desired OPEN position, press the SET button 2. The door will now automatically close and open to calculate the safety obstruction settings.

F - Setting the PET Mode position

When activated, PET mode drives the door to a preset position from the close position, therefore allowing a pet or parcel to go under the door.

- a. Drive and stop the door at the desired PET mode open position by pressing the transmitter button coded for Open/Stop/Close operation.
- b. Press the MODE button repetitively until the GEAR  LED is lit.
- c. Press OPEN button  to save PET position - Main light will flash and both OPEN and CLOSE LED will light up.

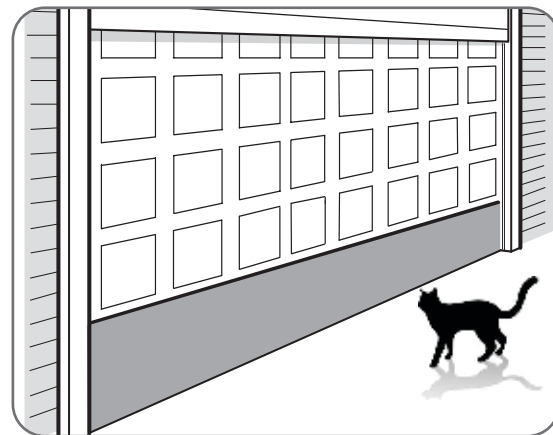

G - Setting up Tilt Door

Prior to limit set up, the opener can be set to J-Type Tilt Profile. This process allows the opener to pre-set to J-Type settings where the limit is not greater than 1500mm. If J-Type is selected, the speed is customised and cannot be changed.

- a. Press the MODE button repetitively until the GEAR  LED starts flashing.
- b. Press and hold STOP / SET button for 2 seconds to check the door type, until the main courtesy light turns solid ON or OFF.
 - Main courtesy light ON - Tilt type (J-Type only)
 - Main courtesy light OFF - Sectional type
- c. Press and hold STOP / SET for 6 seconds to change the door type, until the main courtesy light turns solid ON or OFF. If required, repeat step b to check the door type selected.
- d. Press MODE button to exit the door selection mode. Proceed to Section 6.4 to set the limits.

