

1

2

3

4

5

6

A

B

C

D

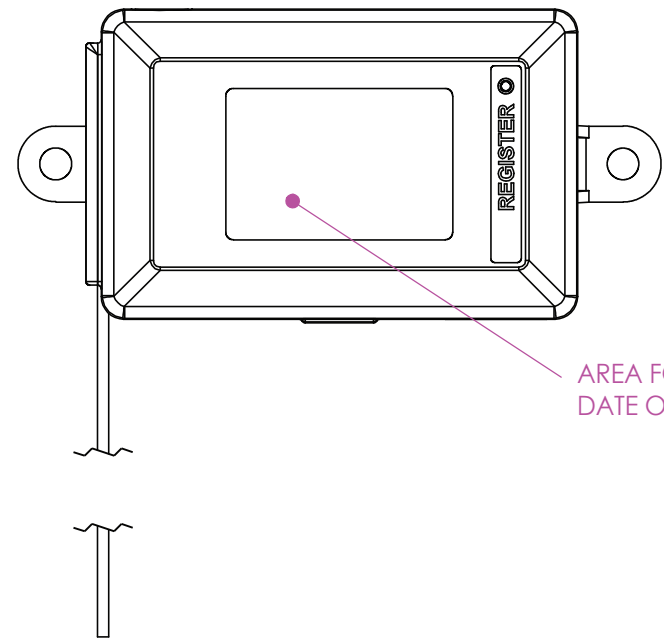
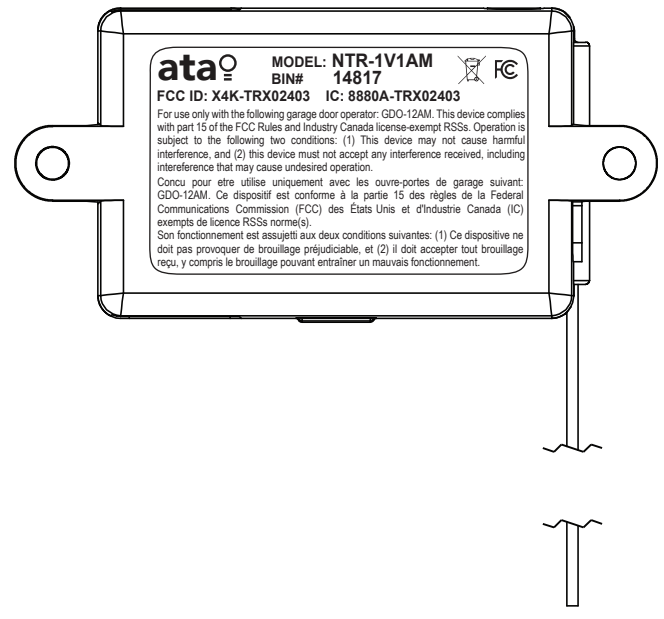

AREA FOR: QR-CODE, SSID &
DATE OF MANUFACTURE

DESCRIPTION	QTY	MAT'L	REMARKS
		LEXAN 0.18THK	ADHESIVE BACKING

Automatic Technology Australia Pty Ltd.
 6-8 FIVEWAYS BOULEVARD, KEYSBOROUGH, VIC, 3173, AUSTRALIA
 PHONE: +61(0) 3 9791 0200 FAX: +61(0) 3 9791 0250
 WEB: www.ata-aust.com.au

GENERAL TOLERANCES:
 DECIMAL: 0.X ±0.1 RADIUS: 0.5
 0.XX ±0.05 CHAMFER: 0.5 x 45°
 ANGLE: ±0.5° SURFACE FINISH
DEBUR AND BREAK SHARP EDGES

TITLE:
LABEL AUTO-KI SMART MODULE NTR-1V1AM

NAME G.GAFF
 DATE 19/05/21

DOCUMENT NO. **160191_02**
 SCALE: 1 : 1 PART NO. 14818

SHEET
A4