

1

2

3

4

5

6

A

B

C

D

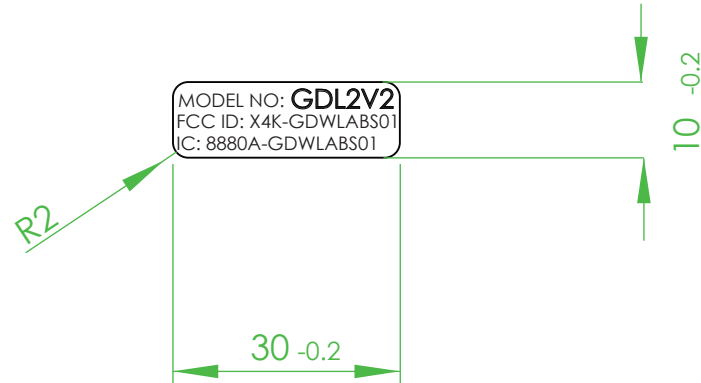
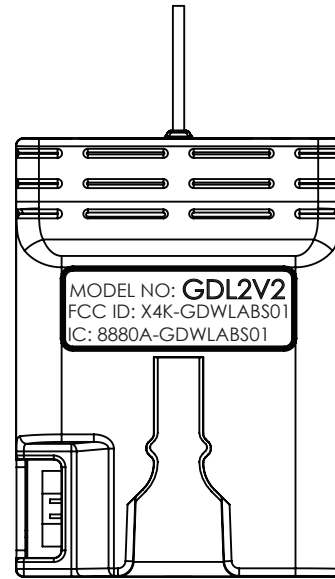

NOTE: ALL TEXT IS BLACK UNLESS OTHERWISE SPECIFIED
BACKGROUND: WHITE

		LEXAN 0.18THK	ADHESIVE BACKING
DESCRIPTION		QTY	REMARKS
<p>PROPRIETARY AND CONFIDENTIAL THE INFORMATION CONTAINED IN THIS DRAWING IS THE SOLE PROPERTY OF AUTOMATIC TECHNOLOGY AUSTRALIA Pty Ltd. ANY REPRODUCTION IN PART OR AS A WHOLE WITHOUT THE WRITTEN PERMISSION OF AUTOMATIC TECHNOLOGY AUSTRALIA Pty Ltd. IS PROHIBITED.</p> <p>GENERAL TOLERANCES: DECIMAL: 0.X ±0.1 RADIUS: 0.5 0.XX ±0.05 CHAMFER: 0.5 x 45° ANGLE: ±0.5° SURFACE FINISH</p> <p>DEBUR AND BREAK SHARP EDGES</p>			
<p>Automatic Technology Australia Pty Ltd. 6-8 FIVEWAYS BOULEVARD, KEYSBOROUGH, VIC, 3173, AUSTRALIA PHONE: +61(0) 3 9791 0200 FAX: +61(0) 3 9791 0250 WEB: www.ata-aust.com.au</p>			
<p>TITLE: LABEL IDENTITY BS-GDL2V2 SDO AM</p>			
NAME	G.GAFF	DOCUMENT NO.	160787_00
DATE	22/03/22	SCALE:	1 : 1
		PART NO.	TBA
			SHEET A4