

A

B

C

D

LIGHT GREY: BACKGROUND

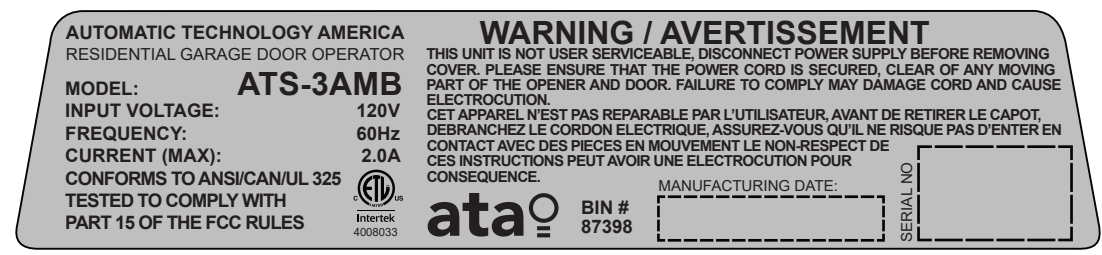
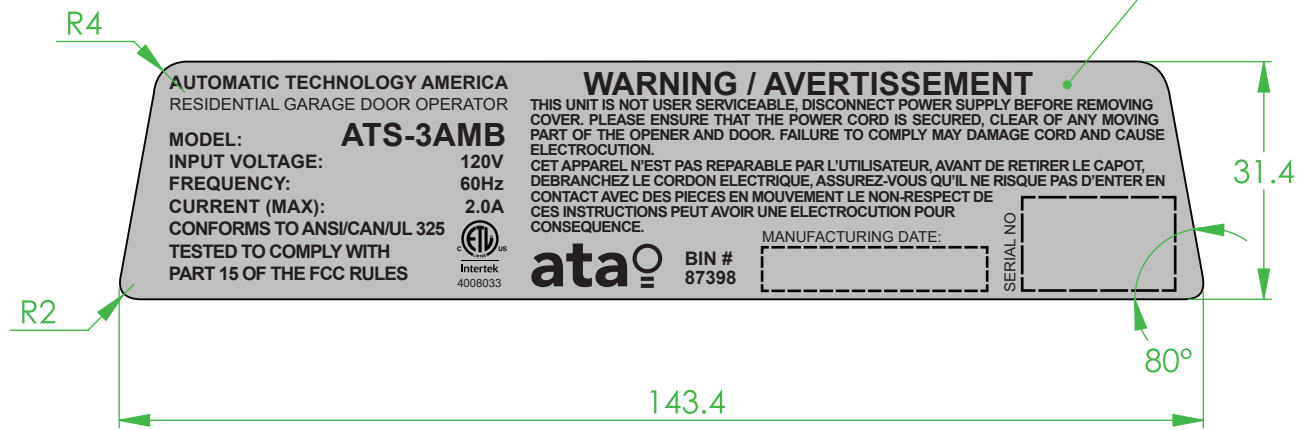

NOTE: ALL TEXT & ARTWORK COLOURS ARE BLACK UNLESS OTHERWISE SPECIFIED

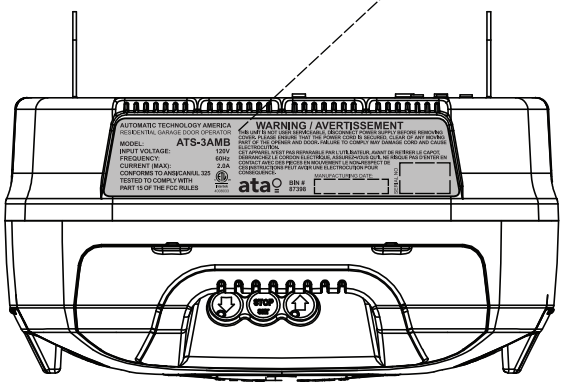

DESCRIPTION	QTY	MAT'L	REMARKS
	1	LEXAN 8B35 0.18THK	9495MP ADHESIVE BACKING

PROPRIETARY AND CONFIDENTIAL
 THE INFORMATION CONTAINED IN THIS DRAWING IS THE SOLE PROPERTY OF AUTOMATIC TECHNOLOGY AUSTRALIA Pty Ltd. ANY REPRODUCTION IN PART OR AS A WHOLE WITHOUT THE WRITTEN PERMISSION OF AUTOMATIC TECHNOLOGY AUSTRALIA Pty Ltd. IS PROHIBITED.

Automatic Technology Australia Pty Ltd.
 6-8 FIVEWAYS BOULEVARD, KEYSBOROUGH, VIC, 3173, AUSTRALIA
 PHONE: +61(0) 3 9791 0200 FAX: +61(0) 3 9791 0250
 WEB: www.ata-aust.com.au

GENERAL TOLERANCES:
 DECIMAL: 0.X ±0.1 RADIUS: 0.5
 0.XX ±0.05 CHAMFER: 0.5 x 45°
 ANGLE: ±0.5° SURFACE FINISH

TITLE:
WARNING INFO LABEL_ATS-3AMB

DEBUR AND BREAK SHARP EDGES
 NAME G.GAFF
 DATE 22/03/21

DOCUMENT NO. **160733_00**
 SCALE: 1 : 1 PART NO. 87471
 SHEET **A4**

A

B

C

D

LIGHT GREY: BACKGROUND

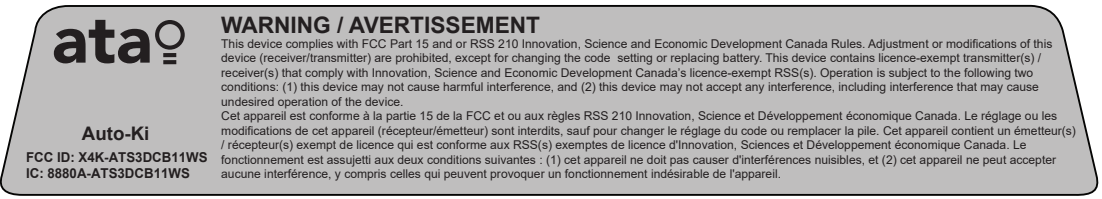
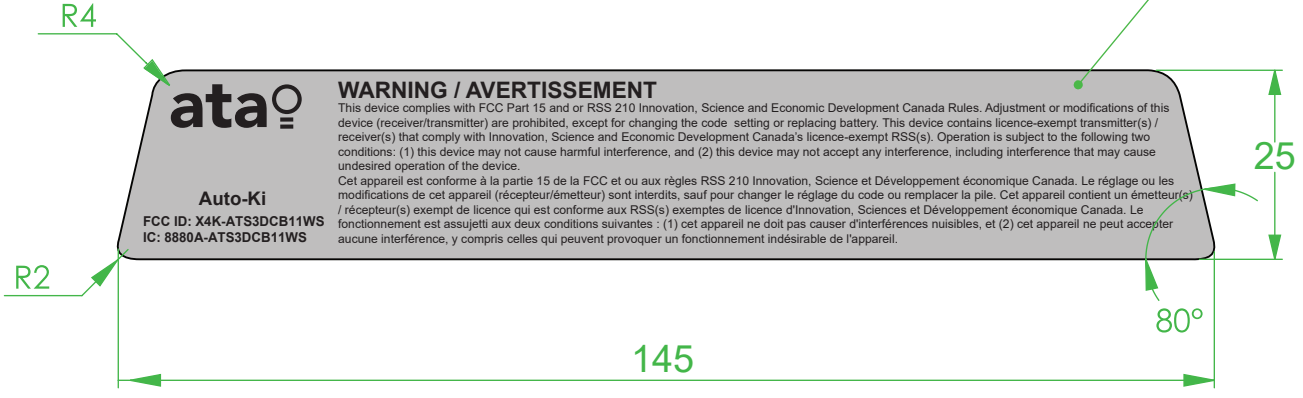

NOTE: ALL TEXT & ARTWORK COLOURS ARE BLACK UNLESS OTHERWISE SPECIFIED

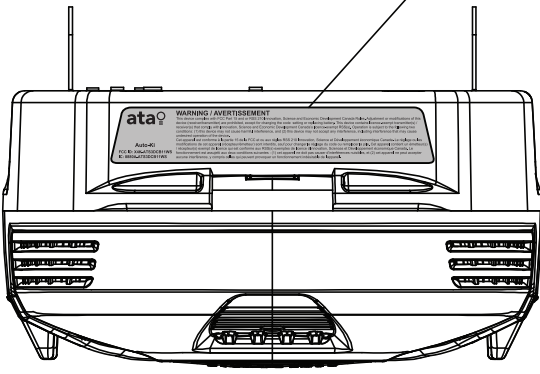

DESCRIPTION	QTY	MAT'L	REMARKS
	1	LEXAN 8B35 0.18THK	9495MP ADHESIVE BACKING

PROPRIETARY AND CONFIDENTIAL
 THE INFORMATION CONTAINED IN THIS DRAWING IS THE SOLE PROPERTY OF AUTOMATIC TECHNOLOGY AUSTRALIA Pty Ltd. ANY REPRODUCTION IN PART OR AS A WHOLE WITHOUT THE WRITTEN PERMISSION OF AUTOMATIC TECHNOLOGY AUSTRALIA Pty Ltd. IS PROHIBITED.

Automatic Technology Australia Pty Ltd.
 6-8 FIVEWAYS BOULEVARD, KEYSBOROUGH, VIC, 3173, AUSTRALIA
 PHONE: +61(0) 3 9791 0200 FAX: +61(0) 3 9791 0250
 WEB: www.ata-aust.com.au

GENERAL TOLERANCES: DECIMAL: 0.X ±0.1 RADIUS: 0.5 0.XX ±0.05 CHAMFER: 0.5 x 45° ANGLE: ±0.5° SURFACE FINISH		TITLE: ATS-3AM FCC STATEMENT LABEL	
DEBUR AND BREAK SHARP EDGES		DOCUMENT NO. 160767_00	
NAME G.GAFF	DATE 16/03/21	SCALE: 1 : 1	PART NO. TBA
			SHEET A4