

**FCC 47 CFR PART 15 SUBPART E AND ANSI C63.10:2013  
TEST REPORT**

**For**

**All In One Panel PC**

**Model : 3365-199**

**Trade Name :** 

**Issued for**

**ADLINK TECHNOLOGY INC.**

**9F, No. 166, Jian Yi Road, Chungho City, Taipei, Taiwan ZIP:235, R.O.C**

**Issued by**

**Compliance Certification Services Inc.  
Hsinchu Lab.**

**No.989-1, Wenshan Rd., Shangshan Village,  
Qionglin Township, Hsinchu County 30741, Taiwan (R.O.C.)**

**TEL: +886-3-5921698**

**FAX: +886-3-5921108**

**<http://www.ccsrf.com>**

**E-Mail : [service@ccsrf.com](mailto:service@ccsrf.com)**

**Issued Date: April 22, 2016**



**Note:** This report shall not be reproduced except in full, without the written approval of Compliance Certification Services Inc. This document may be altered or revised by Compliance Certification Services Inc. personnel only, and shall be noted in the revision section of the document. The client should not use it to claim product endorsement by TAF or any government agencies. The test results of this report relate only to the tested sample identified in this report.

## Revision History

<b>Rev.</b>	<b>Issue Date</b>	<b>Revisions</b>	<b>Effect Page</b>	<b>Revised By</b>
00	01/05/2016	Initial Issue	All Page 96	Gloria Chang
01	04/22/2016	Revised Applicant Address & Antenna Information	P.1, P.4, P.6	Gloria Chang

**TABLE OF CONTENTS**

<b>TITLE</b>	<b>PAGE NO.</b>
<b>1. TEST REPORT CERTIFICATION .....</b>	<b>4</b>
<b>2. EUT DESCRIPTION .....</b>	<b>5</b>
<b>3. DESCRIPTION OF TEST MODES .....</b>	<b>7</b>
<b>4. TEST METHODOLOGY .....</b>	<b>9</b>
<b>5. FACILITIES AND ACCREDITATION .....</b>	<b>9</b>
5.1 FACILITIES .....	9
5.2 ACCREDITATIONS.....	9
5.3 MEASUREMENT UNCERTAINTY .....	10
<b>6. SETUP OF EQUIPMENT UNDER TEST.....</b>	<b>11</b>
<b>7. FCC PART 15.407 REQUIREMENTS .....</b>	<b>12</b>
7.1 6dB BANDWIDTH .....	12
7.2 MAXIMUM CONDUCTED OUTPUT POWER.....	24
7.3 PEAK POWER SPECTRAL DENSITY .....	30
7.4 RADIATED EMISSION.....	56
7.5 CONDUCTED EMISSION .....	83
7.6 FREQUENCY STABILITY .....	88
<b>APPENDIX SETUP PHOTOS .....</b>	<b>93</b>

# 1. TEST REPORT CERTIFICATION

**Applicant** : ADLINK TECHNOLOGY INC.  
**Address** : 9F, No. 166, Jian Yi Road, Chungho City, Taipei, Taiwan  
 ZIP:235, R.O.C  
**Equipment Under Test** : All In One Panel PC  
**Model** : 3365-199  
**Trade Name** :   
**Tested Date** : September 02 ~ October 13, 2015

APPLICABLE STANDARD	
Standard	Test Result
FCC Part 15 Subpart E AND ANSI C63.10:2013	PASS

WE HEREBY CERTIFY THAT: The above equipment has been tested by Compliance Certification Services Inc., and found compliance with the requirements set forth in the technical standards mentioned above. The results of testing in this report apply only to the product/system, which was tested. Other similar equipment will not necessarily produce the same results due to production tolerance and measurement uncertainties.

**Approved by:**



Sb. Lu  
Sr. Engineer

**Reviewed by:**



Gundam Lin  
Sr. Engineer



<b>Type of Modulation</b>	IEEE 802.11a : OFDM (64QAM, 16QAM, QPSK, BPSK) IEEE 802.11an HT20/40 : OFDM (64QAM, 16QAM, QPSK, BPSK)
<b>Antenna Type</b>	PIFA Antenna × 2: Ant. 1 / Chain 1, Antenna Gain: 7.5 dBi Ant. 2 / Chain 0, Antenna Gain : 5.84 dBi
<b>Power Rating</b>	12Vdc
<b>Test Voltage</b>	120Vac, 60Hz
<b>AC Power Cord Type</b>	Non-shielded cable, 1.8m (Detachable)
<b>DC Power Cable Type</b>	Non-shielded cable, 1.2m (Non-detachable), with a ferrite core
<b>I/O Port</b>	RS-232 Port × 2, RJ-45 Port × 1, USB Port × 5, Power Port × 1

**Power Adapter :**

No.	Manufacturer	Model No.	Power Input	Power Output
1	FSP	FSP060-DIBAN2	100-240Vac, 1.5A, 50-60Hz	12Vdc, 5.0A MAX

**Remark :**

1. The sample selected for test was engineering sample that approximated to production product and was provided by manufacturer.
2. For more details, please refer to the User's manual of the EUT.
3. This submittal(s) (test report) is intended for FCC ID: X4D-3365-199 filing to comply with Section 15.207, 15.209 and 15.407 of the FCC Part 15, Subpart E Rules.

### 3. DESCRIPTION OF TEST MODES

The EUT is an 802.11a/b/gn transceiver in All In One Panel PC form factor.

For IEEE 802.11a, 802.11an HT20/HT40 mode (2TX / 2RX) :

Ant. 1 / Chain 0 & Ant. 2 / Chain 1 transmit/receive.

#### Conducted Emission / Radiated Emission Test (Below 1 GHz)

1. The following test modes were scanned during the preliminary test:

No.	Pre-Test Mode
1	TX Mode

2. After the preliminary scan, the following test mode was found to produce the highest emission level.

Final Test Mode		
Emission	Radiated Emission	TX Mode
	Conducted Emission	TX Mode

**Remark :** Then, the above highest emission mode of the configuration of the EUT and cable was chosen for all final test items.

**Conducted / Radiated Emission Test (Above 1 GHz)****IEEE 802.11a, 802.11an HT20 mode**

The EUT had been tested under operating condition.

There are three channels have been tested as following :

**UNII Band 1:**

Channel	Frequency (MHz)
Low	5180
Middle	5200
High	5240

**UNII Band 3:**

Channel	Frequency (MHz)
Low	5745
Middle	5785
High	5825

IEEE 802.11a mode : 6Mbps data rate (worst case) were chosen for full testing.

IEEE 802.11an HT20 mode : 6.5Mbps data rate (worst case) were chosen for full testing.

**IEEE 802.11an HT40 mode**

The EUT had been tested under operating condition.

There are two and three channels have been tested as following :

**UNII Band 1:**

Channel	Frequency (MHz)
Low	5190
High	5230

**UNII Band 3:**

Channel	Frequency (MHz)
Low	5755
High	5795

IEEE 802.11an HT40 mode : 13.5Mbps data rate (worst case) were chosen for full testing.

**Remark :** The field strength of spurious emission was measured in the following position: EUT stand-up position(Z axis), lie-down position(X, Y axis). The worst emission was found in stand-up position(Z axis) and the worst case was recorded.



## 4. TEST METHODOLOGY

The tests documented in this report were performed in accordance with ANSI C63.10:2013 and FCC CFR 47, 15.207, 15.209 and 15.407.

## 5. FACILITIES AND ACCREDITATION

### 5.1 FACILITIES

All measurement facilities used to collect the measurement data are located at

NO. 989-1, Wenshan Rd., Shangshan Village,  
Qionglin Township, Hsinchu County 30741, Taiwan (R.O.C.)

The sites are constructed in conformance with the requirements of ANSI C63.10:2013 and CISPR 22. All receiving equipment conforms to CISPR 16-1-1, CISPR 16-1-2, CISPR 16-1-3, CISPR 16-1-4, CISPR 16-1-5.

### 5.2 ACCREDITATIONS

Our laboratories are accredited and approved by the following approval agencies according to ISO/IEC 17025.

<b>Taiwan</b>	TAF
---------------	-----

The measuring facility of laboratories has been authorized or registered by the following approval agencies.

<b>Canada</b>	INDUSTRY CANADA
<b>Japan</b>	VCCI
<b>Taiwan</b>	BSMI
<b>USA</b>	FCC MRA

Copies of granted accreditation certificates are available for downloading from our web site, <http://www.ccsrf.com>

**Remark:** FCC Designation Number TW1027.

### 5.3 MEASUREMENT UNCERTAINTY

The following table is for the measurement uncertainty, which is calculated as per the document CISPR 16-4-2.

PARAMETER	UNCERTAINTY
Semi Anechoic Chamber (966 Chamber_B) / Radiated Emission, 30 to 1000 MHz	+/- 3.97
Semi Anechoic Chamber (966 Chamber_B) / Radiated Emission, 1 to 18GHz	+/- 3.58
Semi Anechoic Chamber (966 Chamber_B) / Radiated Emission, 18 to 26 GHz	+/- 3.59
Semi Anechoic Chamber (966 Chamber_B) / Radiated Emission, 26 to 40 GHz	+/- 3.81
Conducted Emission (Mains Terminals), 9kHz to 30MHz	+/- 2.48

This uncertainty represents an expanded uncertainty expressed at approximately the 95% confidence level using a coverage factor of k=2.

Consistent with industry standard (e.g. CISPR 22, clause 11, Measurement Uncertainty) determining compliance with the limits shall be base on the results of the compliance measurement. Consequently the measure emissions being less than the maximum allowed emission result in this be a compliant test or passing test.

The acceptable measurement uncertainty value without requiring revision of the compliance statement is base on conducted and radiated emissions being less than  $U_{CISPR}$  which is 3.6dB and 5.2dB respectively. CCS values (called  $U_{Lab}$  in CISPR 16-4-2) is less than  $U_{CISPR}$  as shown in the table above. Therefore, MU need not be considered for compliance.

## 6. SETUP OF EQUIPMENT UNDER TEST

### SUPPORT EQUIPMENT

No.	Product	Manufacturer	Model No.	Serial No.
1	Notebook PC	HP	ProBook 4421s	CNF03242PJ

No.	Signal Cable Description
1	Non-shielded RJ-45 cable, 12m × 1

### SETUP DIAGRAM FOR TESTS

EUT & peripherals setup diagram is shown in appendix setup photos.

### EUT OPERATING CONDITION

1. EUT & peripherals setup diagram is shown in appendix setup photos.

2. TX Mode:

- ⇒ **Tx Data Rate:** 6Mbps Bandwidth 20 (IEEE 802.11a mode)  
6.5Mbps Bandwidth 20 (IEEE 802.11an HT20 mode)  
13.5Mbps Bandwidth 40 (IEEE 802.11an HT40 mode)

⇒ **Power control :**

#### **UNII Band 1**

- IEEE 802.11a Channel Low (5180MHz) Chain 0/1 Power set 17
- IEEE 802.11a Channel Mid (5200MHz) Chain 0/1 Power set 18
- IEEE 802.11a Channel High (5240MHz) Chain 0/1 Power set 18
- IEEE 802.11an HT20 Channel Low (5180MHz) Chain 0/1 Power set 16.5
- IEEE 802.11an HT20 Channel Mid (5200MHz) Chain 0/1 Power set 18
- IEEE 802.11an HT20 Channel High (5240MHz) Chain 0/1 Power set 18
- IEEE 802.11an HT40 Channel Low (5190MHz) Chain 0/1 Power set 11
- IEEE 802.11an HT40 Channel High (5230MHz) Chain 0/1 Power set 18

#### **UNII Band 3**

- IEEE 802.11a Channel Low (5745MHz) Chain 0/1 Power set 7.5
- IEEE 802.11a Channel Mid (5785MHz) Chain 0/1 Power set 18
- IEEE 802.11a Channel High (5825MHz) Chain 0/1 Power set 12.5
- IEEE 802.11an HT20 Channel Low (5745MHz) Chain 0/1 Power set 7.5
- IEEE 802.11an HT20 Channel Mid (5785MHz) Chain 0/1 Power set 18
- IEEE 802.11an HT20 Channel High (5825MHz) Chain 0/1 Power set 11.5
- IEEE 802.11an HT40 Channel Low (5755MHz) Chain 0/1 Power set 7.5
- IEEE 802.11an HT40 Channel High (5795MHz) Chain 0/1 Power set 14.5

3. All of the functions are under run.

4. Start test.

## 7. FCC PART 15.407 REQUIREMENTS

### 7.1 6dB BANDWIDTH

#### LIMITS

According to § 15.407 (e), within the 5.725-5.85 GHz band, the minimum 6 dB bandwidth of U-NII devices shall be at least 500 kHz.

#### TEST EQUIPMENT

Name of Equipment	Manufacturer	Model	Serial Number	Calibration Due
EXA Signal Analyzer	Agilent	N9010A	MY52220817	03/19/2016

*Remark: Each piece of equipment is scheduled for calibration once a year.*

#### TEST SETUP

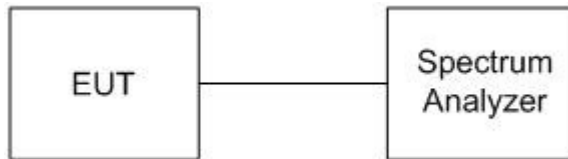

#### TEST PROCEDURE

1. Place the EUT on the table and set it in the transmitting mode.
2. Remove the antenna from the EUT and then connect a low loss RF cable from the antenna port to the spectrum analyzer.
3. Set the spectrum analyzer as RBW = 100kHz, VBW = 300kHz, Sweep = auto.
4. Mark the peak frequency and -6dB (upper and lower) frequency.
5. Repeat until all the rest channels are investigated.

**TEST RESULTS**

**IEEE 802.11a Mode**

U-NII	Channel	Channel Frequency (MHz)	6dB Bandwidth (MHz)		Limit (kHz)	Pass / Fail
			Chain 0	Chain 1		
Band 3	Low	5745	16.4700	16.4900	500	PASS
	Middle	5785	16.4000	16.4900	500	PASS
	High	5825	16.4500	16.4300	500	PASS

**IEEE 802.11an HT20 Mode**

U-NII	Channel	Channel Frequency (MHz)	6dB Bandwidth (MHz)		Limit (kHz)	Pass / Fail
			Chain 0	Chain 1		
Band 3	Low	5745	17.6600	17.6900	500	PASS
	Middle	5785	17.6800	17.5800	500	PASS
	High	5825	17.5500	17.7500	500	PASS

**IEEE 802.11an HT40 Mode**

U-NII	Channel	Channel Frequency (MHz)	6dB Bandwidth (MHz)		Limit (kHz)	Pass / Fail
			Chain 0	Chain 1		
Band 3	Low	5755	36.1300	36.2000	500	PASS
	High	5795	36.0300	35.8400	500	PASS

**6dB BANDWIDTH**

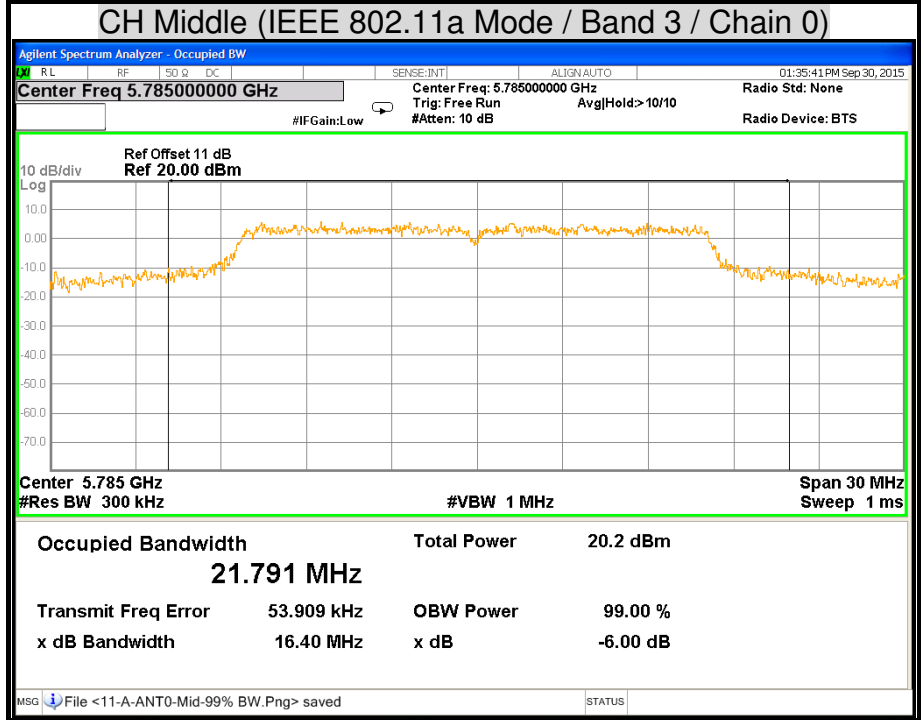
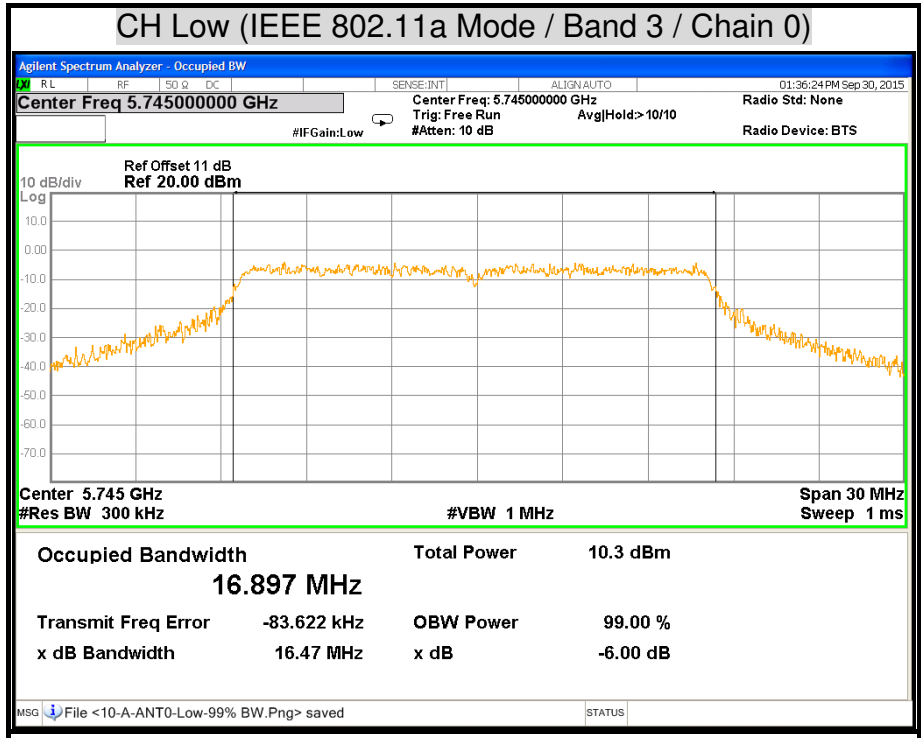

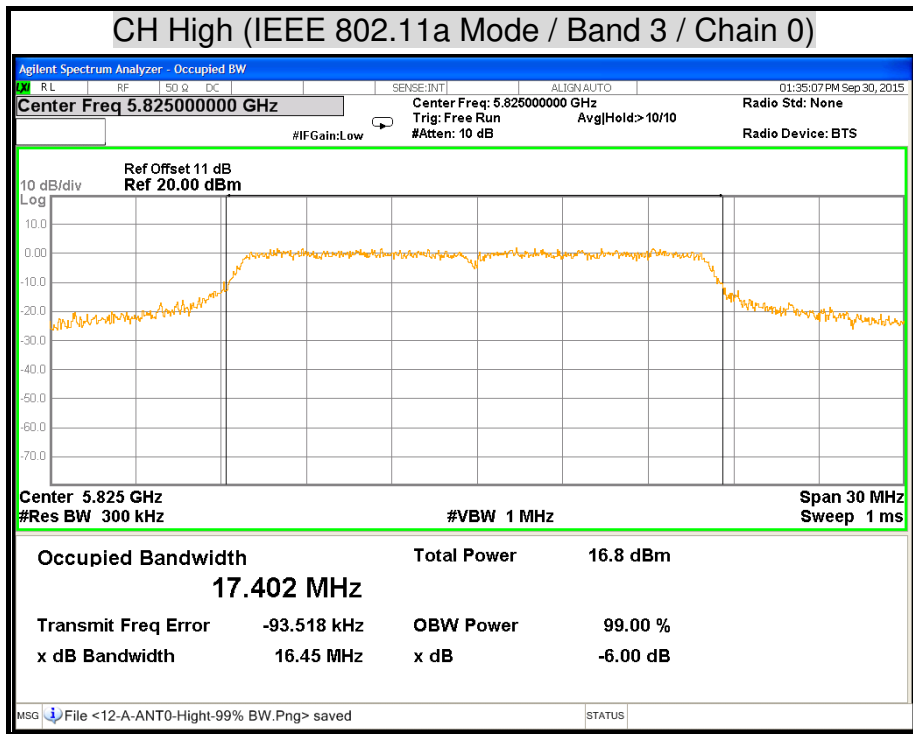

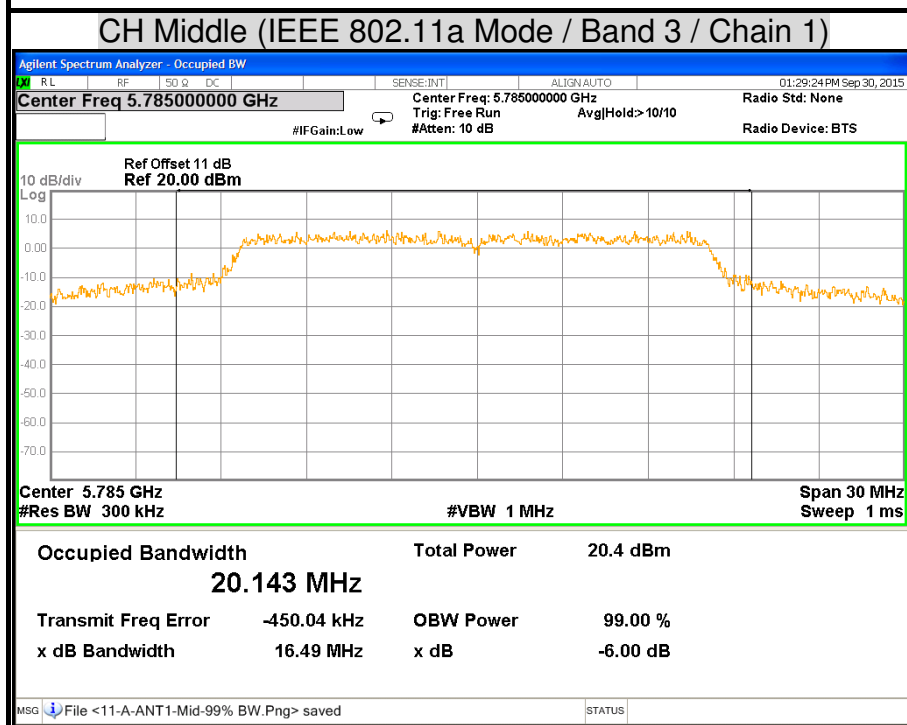
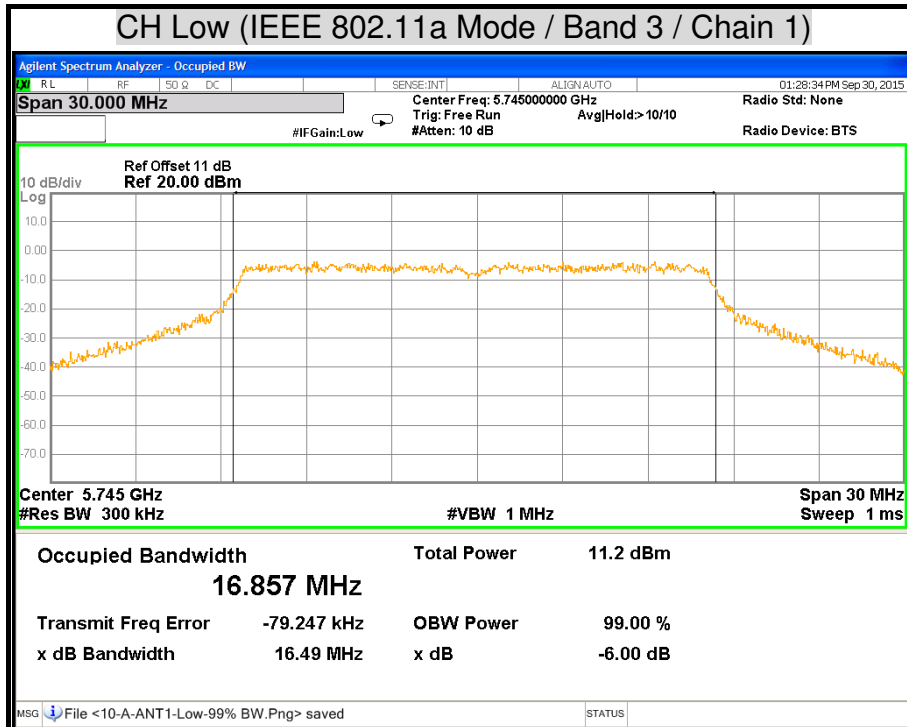



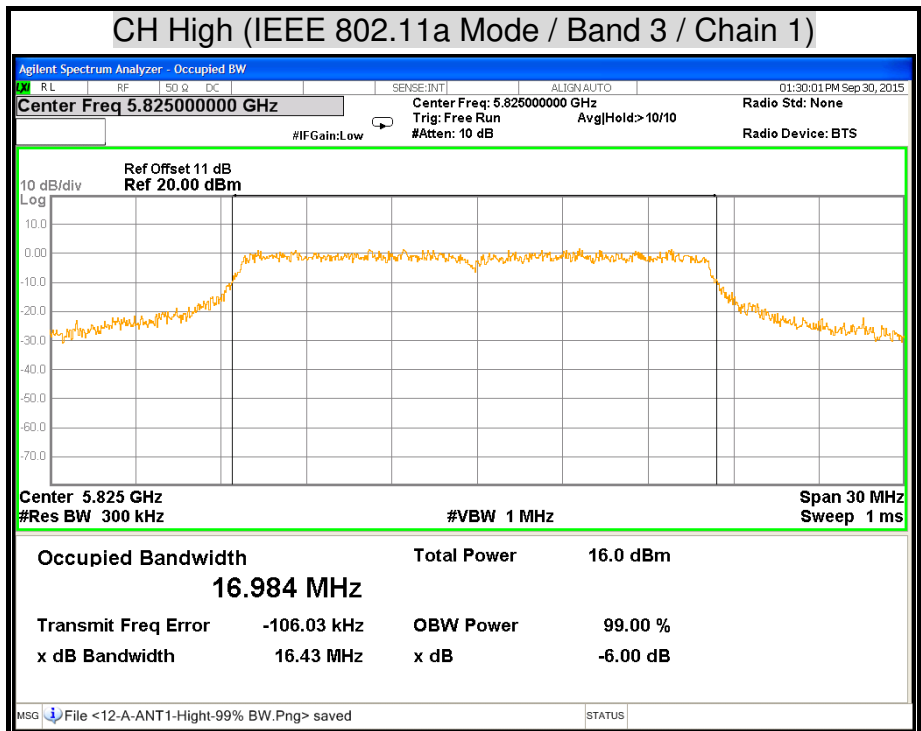

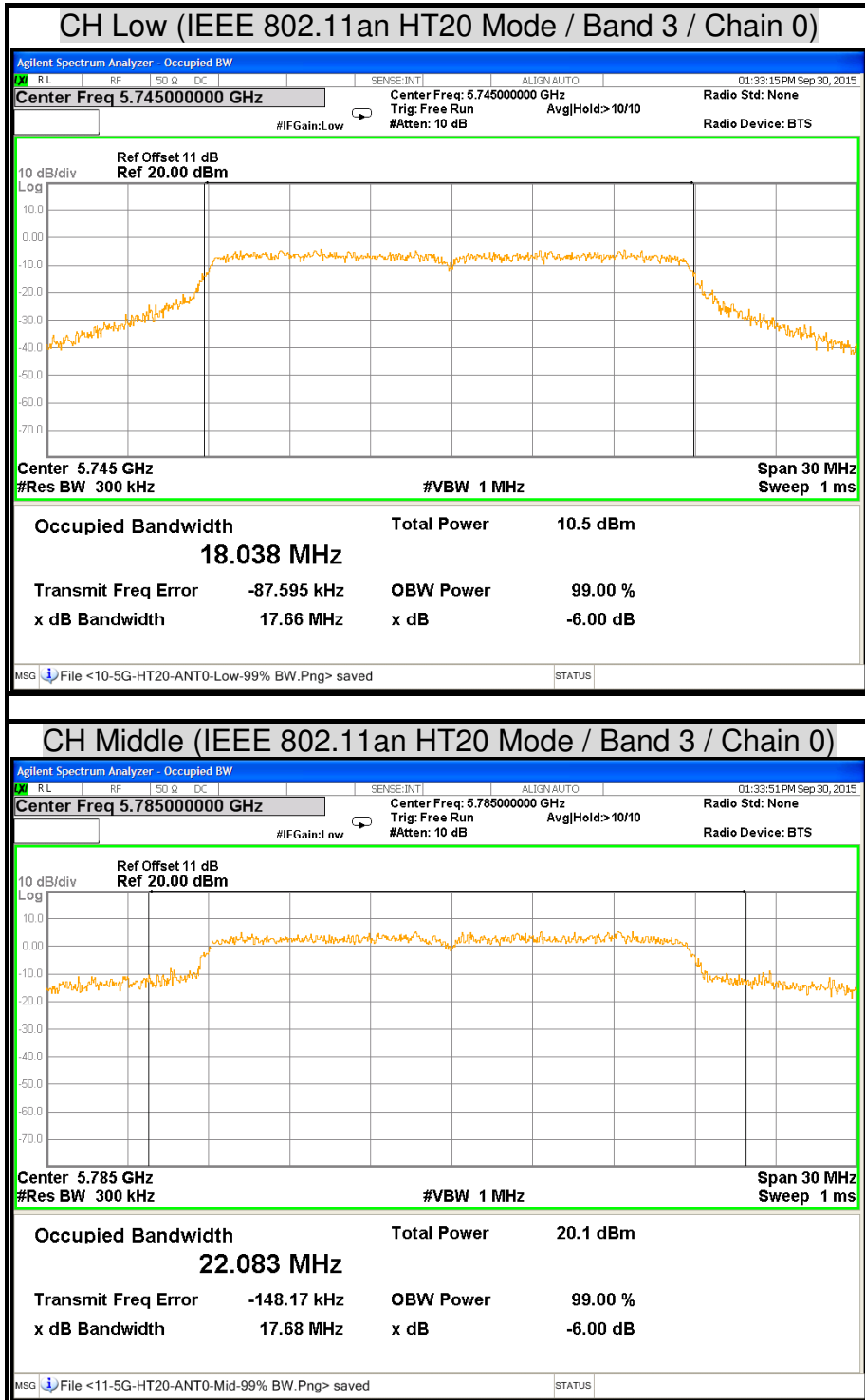

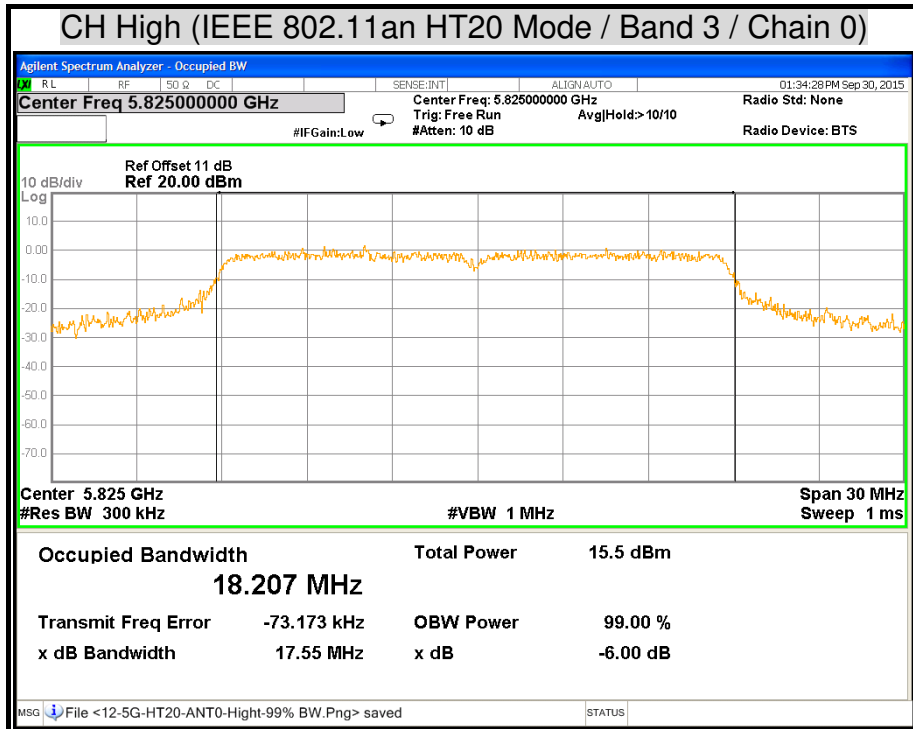

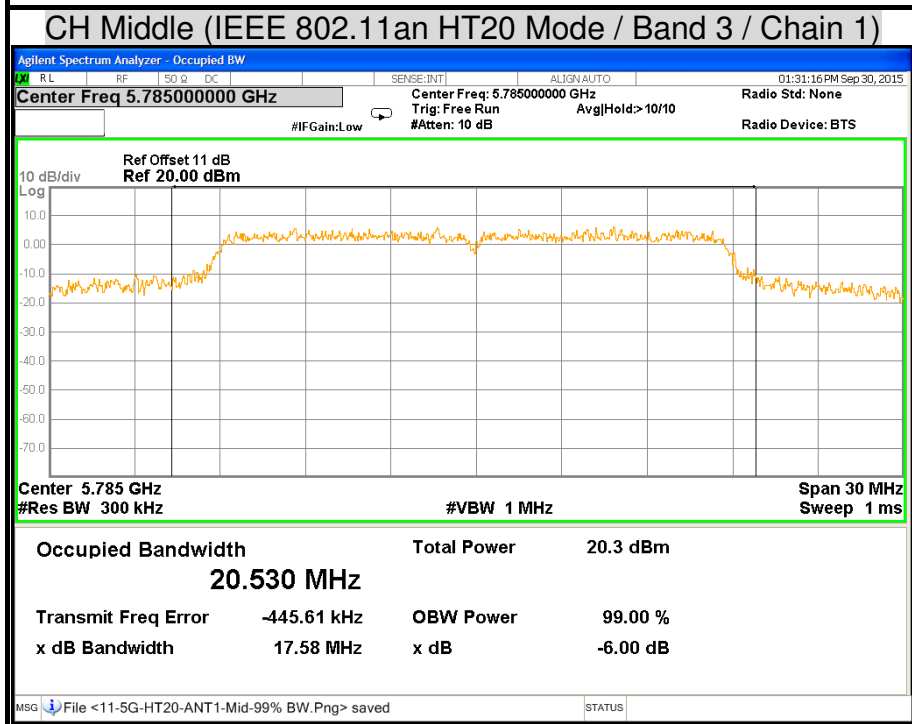
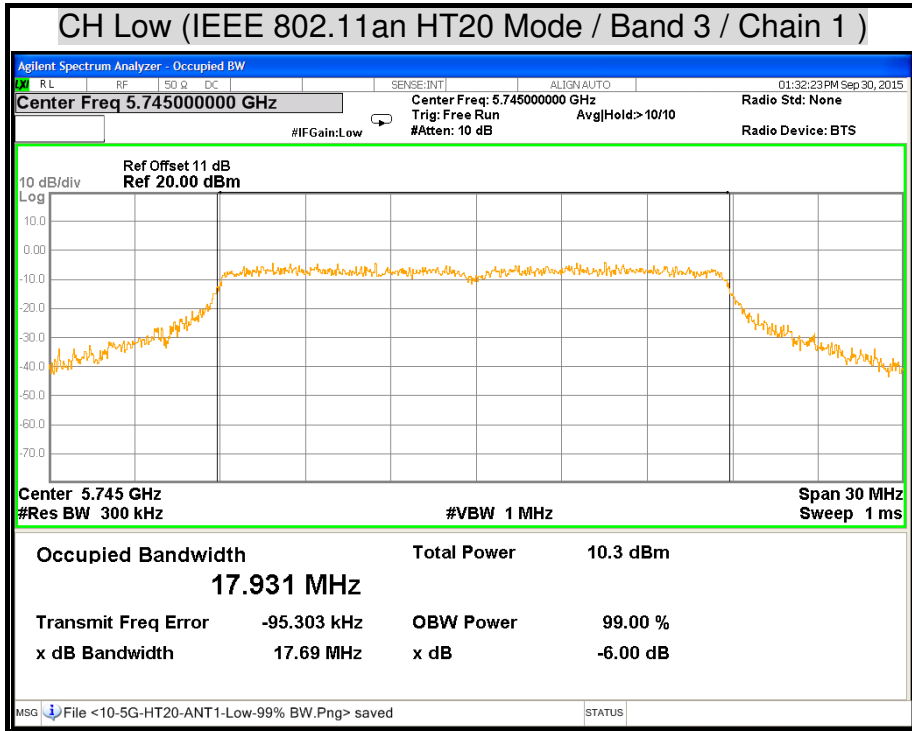

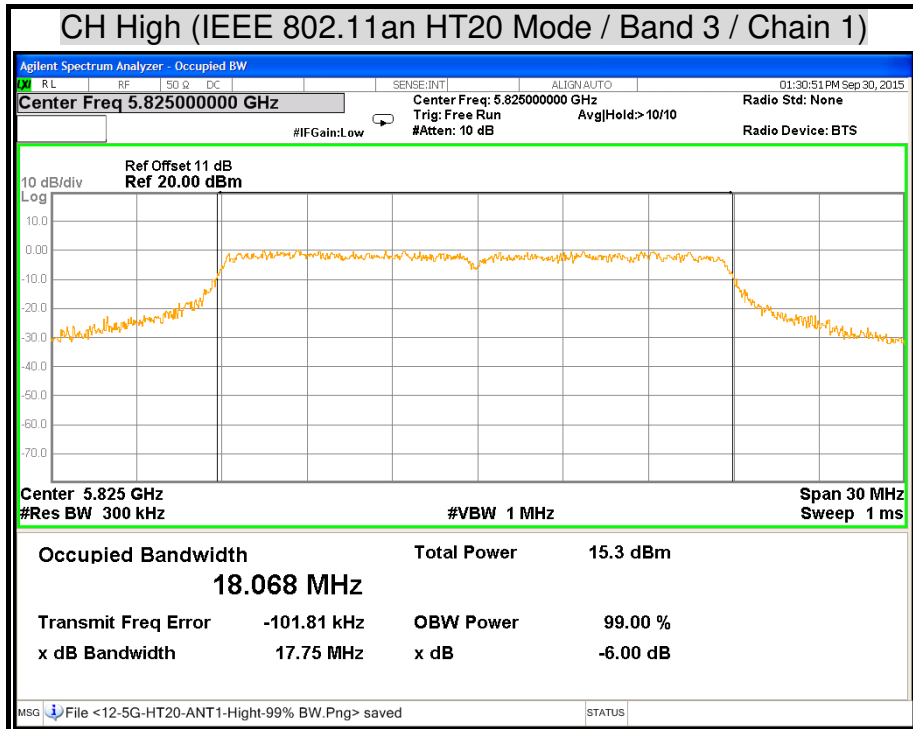

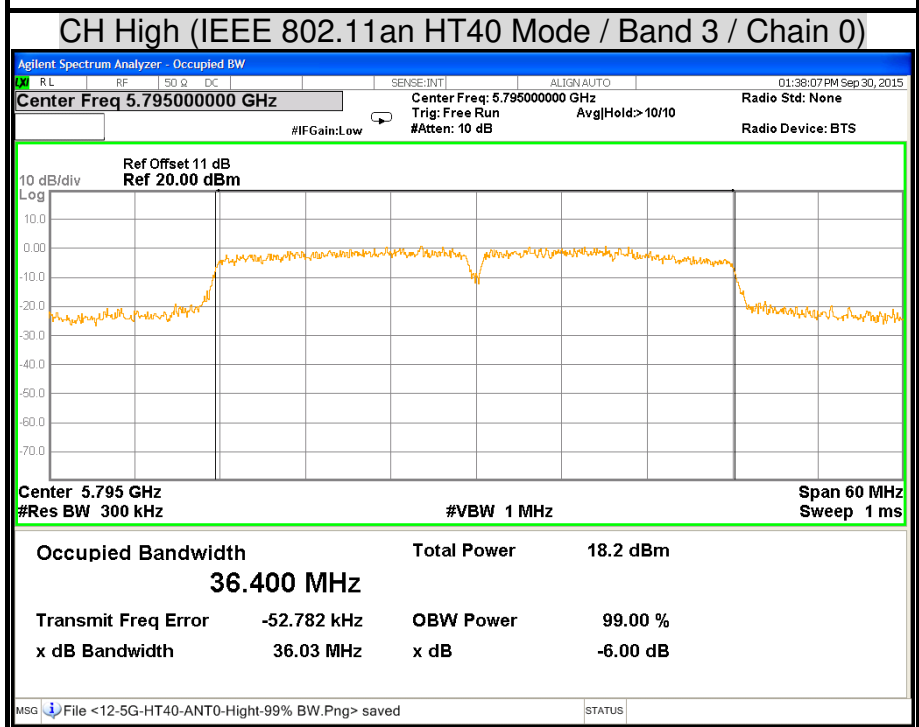
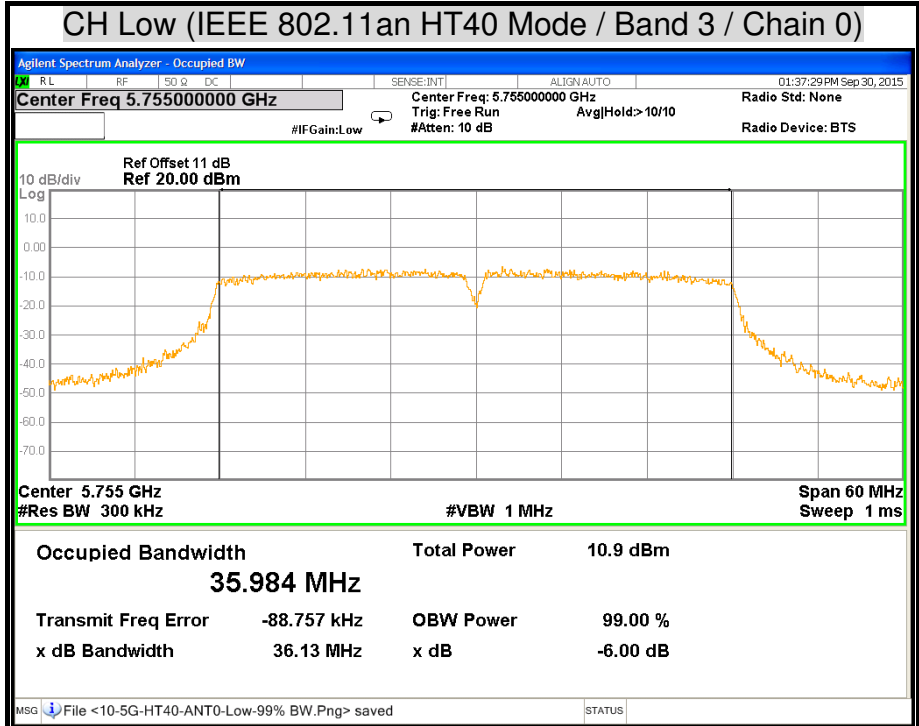

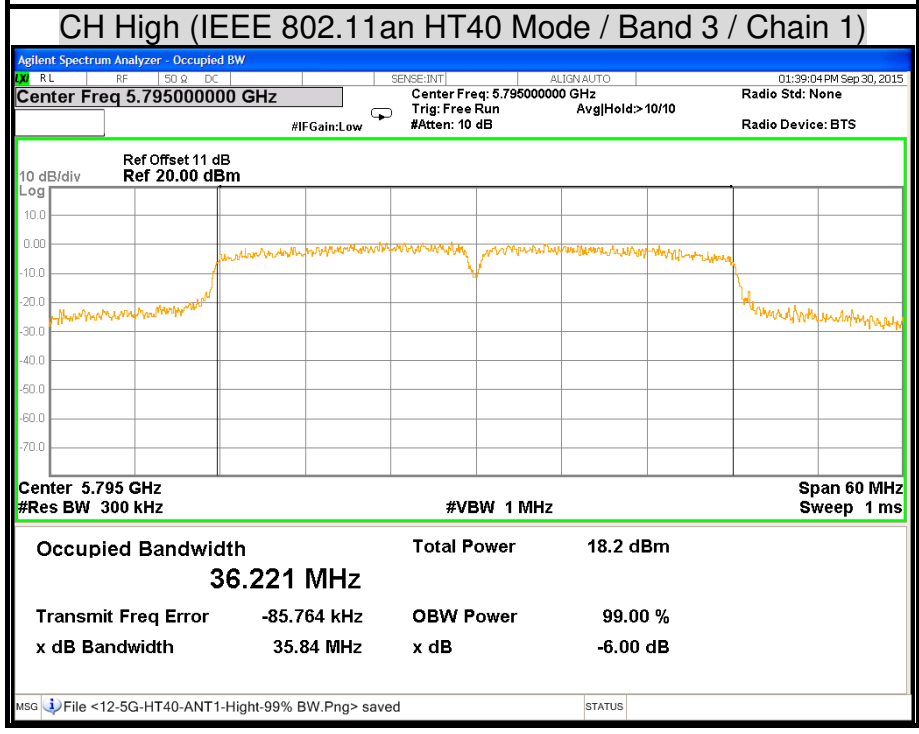
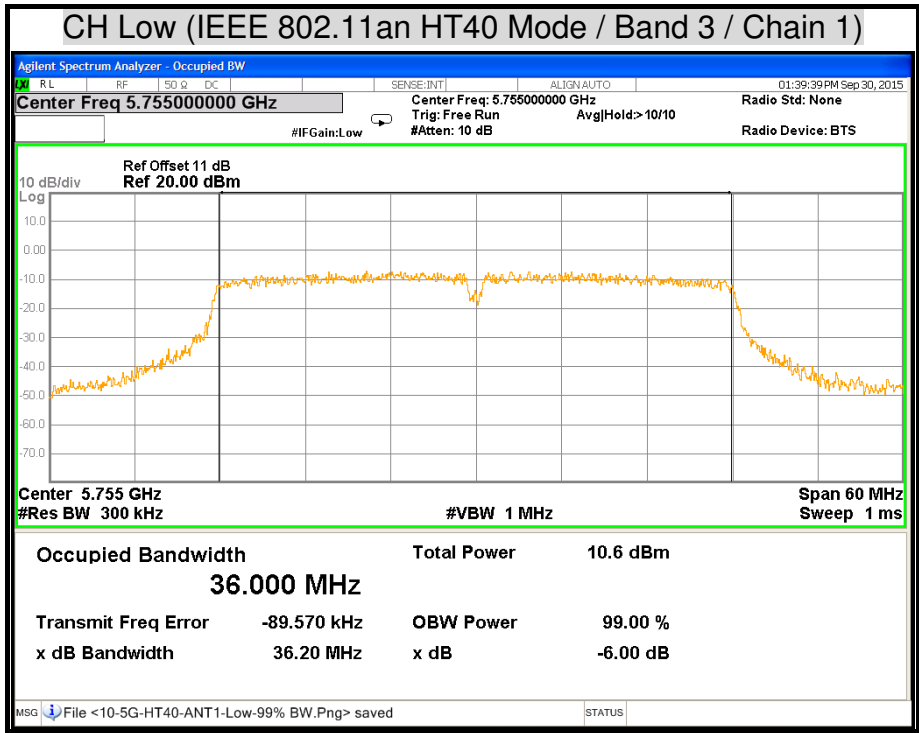

## 7.2 MAXIMUM CONDUCTED OUTPUT POWER

### LIMITS

#### § 15.407(a)

(1) For the band 5.15-5.25 GHz,

(I) For an outdoor access point operating in the band 5.15-5.25 GHz, the maximum conducted output power over the frequency band of operation shall not exceed 1W provided the maximum antenna gain does not exceed 6 dBi. In addition, the maximum power spectral density shall not exceed 17 dBm in any 1 megahertz band. If transmitting antennas of directional gain greater than 6 dBi are used, both the maximum conducted output power and the maximum power spectral density shall be reduced by the amount in dB that the directional gain of the antenna exceeds 6 dBi. The maximum e.i.r.p. at any elevation angle above 30 degrees as measured from the horizon must not exceed 125 mW (21 dBm).

(II) For an indoor access point operating in the band 5.15-5.25 GHz, the maximum conducted output power over the frequency band of operation shall not exceed 1W provided the maximum antenna gain does not exceed 6 dBi. In addition, the maximum power spectral density shall not exceed 17dBm in any 1 megahertz band. If transmitting antennas of directional gain greater than 6dBi are used, both the maximum conducted output power and the maximum power spectral density shall be reduced by the amount in dB that the directional gain of the antenna exceeds 6dBi.

(III) For fixed point-to-point access points operating in the band 5.15-5.25 GHz, the maximum conducted output power over the frequency band of operation shall not exceed 1 W. Fixed point-to-point U-NII devices may employ antennas with directional gain up to 23 dBi without any corresponding reduction in the maximum conducted output power or maximum power spectral density. For fixed point-to-point transmitters that employ a directional antenna gain greater than 23 dBi, a 1 dB reduction in maximum conducted output power and maximum power spectral density is required for each 1 dB of antenna gain in excess of 23 dBi. Fixed, point-to-point operations exclude the use of point-to-multipoint systems, omnidirectional applications, and multiple collocated transmitters transmitting the same information. The operator of the U-NII device, or if the equipment is professionally installed, the installer, is responsible for ensuring that systems employing high gain directional antennas are used exclusively for fixed, point-to-point operations.



- (IV) For mobile and portable client devices in the 5.15-5.25 GHz band, the maximum conducted output power over the frequency band of operation shall not exceed 250 mW provided the maximum antenna gain does not exceed 6 dBi. In addition, the maximum power spectral density shall not exceed 11 dBm in any 1 megahertz band. If transmitting antennas of directional gain greater than 6 dBi are used, both the maximum conducted output power and the maximum power spectral density shall be reduced by the amount in dB that the directional gain of the antenna exceeds 6 dBi.
- (2) For the 5.25-5.35 GHz and 5.47-5.725 GHz bands, the maximum conducted output power over the frequency bands of operation shall not exceed the lesser of 250 mW or  $11 \text{ dBm} + 10 \log B$ , where B is the 26 dB emission bandwidth in megahertz. In addition, the maximum power spectral density shall not exceed 11 dBm in any 1 megahertz band. If transmitting antennas of directional gain greater than 6 dBi are used, both the maximum conducted output power and the maximum power spectral density shall be reduced by the amount in dB that the directional gain of the antenna exceeds 6 dBi.
- (3) For the band 5.725-5.85 GHz, the maximum conducted output power over the frequency band of operation shall not exceed 1 W. In addition, the maximum power spectral density shall not exceed 30 dBm in any 500-kHz band. If transmitting antennas of directional gain greater than 6 dBi are used, both the maximum conducted output power and the maximum power spectral density shall be reduced by the amount in dB that the directional gain of the antenna exceeds 6 dBi. However, fixed point-to-point U-NII devices operating in this band may employ transmitting antennas with directional gain greater than 6 dBi without any corresponding reduction in transmitter conducted power. Fixed, point-to-point operations exclude the use of point-to-multipoint systems, omnidirectional applications, and multiple collocated transmitters transmitting the same information. The operator of the U-NII device, or if the equipment is professionally installed, the installer, is responsible for ensuring that systems employing high gain directional antennas are used exclusively for fixed, point-to-point operations.

§ KDB 662911 : For power measurements on IEEE 802.11 devices

Array Gain = 0 dB (i.e., no array gain) for  $N_{\text{ANT}} \leq 4$  ;

Array Gain = 0 dB (i.e., no array gain) for channel widths  $\geq 40$  MHz for any  $N_{\text{ANT}}$  ;

Array Gain =  $5 \log(N_{\text{ANT}}/N_{\text{SS}})$  dB or 3 dB, whichever is less for 20-MHz channel widths with  $N_{\text{ANT}} \geq 5$ .

**TEST EQUIPMENT**

Name of Equipment	Manufacturer	Model	Serial Number	Calibration Due
Power Meter	ANRITSU	ML2495A	1149001	12/11/2015
Power Sensor	ANRITSU	MA2411B	1126148	12/11/2015

*Remark: Each piece of equipment is scheduled for calibration once a year.*

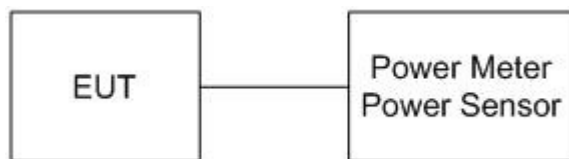
**TEST SETUP****TEST PROCEDURE**

The transmitter output is connected to the power meter. The power meter is set to the power detection.

**TEST RESULTS**

**IEEE 802.11a Mode / UNII Band 1**

Channel	Channel Frequency (MHz)	Power (dBm)		Power Total		Power Limit		Pass / Fail
		Chain 0	Chain 1	(dBm)	(W)	(dBm)	(W)	
Low	5180	14.26	14.12	17.20	0.0525	20.29	0.1069	PASS
Middle	5200	15.09	15.03	18.07	0.0641	20.29	0.1069	PASS
High	5240	15.03	15.58	18.32	0.0679	20.29	0.1069	PASS

**Remark:**

1. At final test to get the worst-case emission at 6 Mbps.
2. The cable assembly insertion loss of 10.5 dB (including 10 dB pad and 0.5dB cable) was Entered as an offset in the power meter to allow for direct reading of power.
3. The directional gain is 9.71dBi which is more than 6dBi, the limit should be 20.29dBm.
4. Total peak power = Chain 0 + Chain 1.

**IEEE 802.11an HT20 Mode / UNII Band 1**

Channel	Channel Frequency (MHz)	Power (dBm)		Power Total		Power Limit		Pass / Fail
		Chain 0	Chain 1	(dBm)	(W)	(dBm)	(W)	
Low	5180	13.56	13.62	16.60	0.0457	20.29	0.1069	PASS
Middle	5200	15.04	15.28	18.17	0.0656	20.29	0.1069	PASS
High	5240	15.04	15.23	18.15	0.0653	20.29	0.1069	PASS

**Remark:**

1. At final test to get the worst-case emission at 6.5 Mbps.
2. The cable assembly insertion loss of 10.5 dB (including 10 dB pad and 0.5 dB cable) was Entered as an offset in the power meter to allow for direct reading of power.
3. The directional gain is 9.71dBi which is more than 6dBi, the limit should be 20.29dBm.
4. Total peak power = Chain 0 + Chain 1.

**IEEE 802.11an HT40 Mode / UNII Band 1**

Channel	Channel Frequency (MHz)	Power (dBm)		Power Total		Power Limit		Pass / Fail
		Chain 0	Chain 1	(dBm)	(W)	(dBm)	(W)	
Low	5190	7.91	8.13	11.03	0.0127	20.29	0.1069	PASS
High	5230	15.26	16.13	18.73	0.0746	20.29	0.1069	PASS

**Remark:**

1. At final test to get the worst-case emission at 13.5 Mbps.
2. The cable assembly insertion loss of 10.5 dB (including 10 dB pad and 0.5 dB cable) was Entered as an offset in the power meter to allow for direct reading of power.
3. The directional gain is 9.71dBi which is more than 6dBi, the limit should be 20.29dBm.
4. Total peak power = Chain 0 + Chain 1.

**IEEE 802.11a Mode / UNII Band 3**

Channel	Channel Frequency (MHz)	Power (dBm)		Power Total		Power Limit		Pass / Fail
		Chain 0	Chain 1	(dBm)	(W)	(dBm)	(W)	
Low	5745	5.89	5.68	8.80	0.0076	26.29	0.4256	PASS
Middle	5785	15.17	15.53	18.36	0.0685	26.29	0.4256	PASS
High	5825	11.57	10.86	14.24	0.0265	26.29	0.4256	PASS

**Remark:**

1. At final test to get the worst-case emission at 6 Mbps.
2. The cable assembly insertion loss of 10.5 dB (including 10 dB pad and 0.5 dB cable) was Entered as an offset in the power meter to allow for direct reading of power.
3. The directional gain is 9.71dBi which is more than 6dBi, the limit should be 26.29dBm.
4. Total peak power = Chain 0 + Chain 1.

**IEEE 802.11an HT20 Mode / UNII Band 3**

Channel	Channel Frequency (MHz)	Power (dBm)		Power Total		Power Limit		Pass / Fail
		Chain 0	Chain 1	(dBm)	(W)	(dBm)	(W)	
Low	5745	5.97	6.03	9.01	0.0080	26.29	0.4256	PASS
Middle	5785	15.64	15.69	18.68	0.0738	26.29	0.4256	PASS
High	5825	10.52	10.03	13.29	0.0213	26.29	0.4256	PASS

**Remark:**

1. At final test to get the worst-case emission at 6.5 Mbps.
2. The cable assembly insertion loss of 10.5 dB (including 10 dB pad and 0.5 dB cable) was Entered as an offset in the power meter to allow for direct reading of power.
3. The directional gain is 9.71dBi which is more than 6dBi, the limit should be 26.29dBm.
4. Total peak power = Chain 0 + Chain 1.

**IEEE 802.11an HT40 Mode / UNII Band 3**

Channel	Channel Frequency (MHz)	Power (dBm)		Power Total		Power Limit		Pass / Fail
		Chain 0	Chain 1	(dBm)	(W)	(dBm)	(W)	
Low	5755	5.54	5.72	8.64	0.0073	26.29	0.4256	PASS
High	5795	13.52	13.06	16.31	0.0428	26.29	0.4256	PASS

**Remark:**

1. At final test to get the worst-case emission at 13.5 Mbps.
2. The cable assembly insertion loss of 10.5 dB (including 10 dB pad and 0.5dB cable) was Entered as an offset in the power meter to allow for direct reading of power.
3. The directional gain is 9.71dBi which is more than 6dBi, the limit should be 26.29dBm.
4. Total peak power = Chain 0 + Chain 1.

## 7.3 PEAK POWER SPECTRAL DENSITY

### LIMITS

#### § 15.407 (a)

##### (1) For the band 5.15-5.25 GHz

(I) For an outdoor access point operating in the band 5.15-5.25 GHz, the maximum conducted output power over the frequency band of operation shall not exceed 1 W provided the maximum antenna gain does not exceed 6 dBi. In addition, the maximum power spectral density shall not exceed 17 dBm in any 1 megahertz band. If transmitting antennas of directional gain greater than 6 dBi are used, both the maximum conducted output power and the maximum power spectral density shall be reduced by the amount in dB that the directional gain of the antenna exceeds 6dBi. The maximum e.i.r.p. at any elevation angle above 30 degrees as measured from the horizon must not exceed 125 mW (21 dBm).

(II) For an indoor access point operating in the band 5.15-5.25 GHz, the maximum conducted output power over the frequency band of operation shall not exceed 1 W provided the maximum antenna gain does not exceed 6 dBi. In addition, the maximum power spectral density shall not exceed 17 dBm in any 1 megahertz band. If transmitting antennas of directional gain greater than 6 dBi are used, both the maximum conducted output power and the maximum power spectral density shall be reduced by the amount in dB that the directional gain of the antenna exceeds 6dBi.

(IV) For mobile and portable client devices in the 5.15-5.25 GHz band, the maximum conducted output power over the frequency band of operation shall not exceed 250 mW provided the maximum antenna gain does not exceed 6 dBi. In addition, the maximum power spectral density shall not exceed 11 dBm in any 1 megahertz band. If transmitting antennas of directional gain greater than 6 dBi are used, both the maximum conducted output power and the maximum power spectral density shall be reduced by the amount in dB that the directional gain of the antenna exceeds 6dBi.

- (2) For the 5.25-5.35 GHz and 5.47-5.725 GHz bands, the maximum conducted output power over the frequency bands of operation shall not exceed the lesser of 250 mW or 11 dBm 10 log B, where B is the 26 dB emission bandwidth in megahertz. In addition, the maximum power spectral density shall not exceed 11 dBm in any 1 megahertz band. If transmitting antennas of directional gain greater than 6 dBi are used, both the maximum conducted output power and the maximum power spectral density shall be reduced by the amount in dB that the directional gain of the antenna exceeds 6 dBi.
- (3) For the band 5.725-5.85 GHz, the maximum conducted output power over the frequency band of operation shall not exceed 1 W. In addition, the maximum power spectral density shall not exceed 30 dBm in any 500-kHz band. If transmitting antennas of directional gain greater than 6 dBi are used, both the maximum conducted output power and the maximum power spectral density shall be reduced by the amount in dB that the directional gain of the antenna exceeds 6 dBi. However, fixed point-to-point U-NII devices operating in this band may employ transmitting antennas with directional gain greater than 6 dBi without any corresponding reduction in transmitter conducted power. Fixed, point-to-point operations exclude the use of point-to-multipoint systems, omnidirectional applications, and multiple collocated transmitters transmitting the same information. The operator of the U-NII device, or if the equipment is professionally installed, the installer, is responsible for ensuring that systems employing high gain directional antennas are used exclusively for fixed, point-to-point operations.

**TEST EQUIPMENT**

Name of Equipment	Manufacturer	Model	Serial Number	Calibration Due
EXA Signal Analyzer	Agilent	N9010A	MY52220817	03/19/2016

*Remark: Each piece of equipment is scheduled for calibration once a year.*

**TEST SETUP**



**TEST PROCEDURE**

1. Place the EUT on the table and set it in transmitting mode.  
Remove the antenna from the EUT and then connect a low loss RF cable from the antenna port to the spectrum analyzer.
2. Set the spectrum analyzer as RBW = 1MHz, VBW = 3MHz, Span = Sweep= AUTO
3. Record the max. reading.
4. Repeat the above procedure until the measurements for all frequencies are completed.



**TEST RESULTS**

**IEEE 802.11a Mode**

U-NII	Channel	Channel Frequency (MHz)	PPSD (dBm)		PSD Total (dBm)	Limit (dBm/MHz)	Pass / Fail
			Chain 0	Chain 1			
Band 1	Low	5180	2.79	3.10	5.96	7.29	PASS
	Middle	5200	3.52	3.95	6.75	7.29	PASS
	High	5240	3.69	4.35	7.04	7.29	PASS

**Remark:**

1. At final test to get the worst-case emission at 6Mbps.
2. The cable assembly insertion loss of 10.5 dB (including 10 dB pad and 0.5 dB cable) was Entered as an offset in the spectrum analyzer to allow for direct reading of power.
3. Total power spectral density = Chain 0 + Chain 1.
4. The directional gain is 9.71dBi which is more than 6dBi, the limit should be 7.29dBm.

**IEEE 802.11an HT20 Mode**

U-NII	Channel	Channel Frequency (MHz)	PPSD (dBm)		PSD Total (dBm)	Limit (dBm/MHz)	Pass / Fail
			Chain 0	Chain 1			
Band 1	Low	5180	2.32	1.92	5.13	7.29	PASS
	Middle	5200	3.30	3.31	6.32	7.29	PASS
	High	5240	3.43	3.75	6.60	7.29	PASS

**Remark:**

1. At final test to get the worst-case emission at 6.5Mbps.
2. The cable assembly insertion loss of 10.5 dB (including 10 dB pad and 0.5 dB cable) was Entered as an offset in the spectrum analyzer to allow for direct reading of power.
3. Total power spectral density = Chain 0 + Chain 1.
4. The directional gain is 9.71dBi which is more than 6dBi, the limit should be 7.29dBm.

**IEEE 802.11n HT40 Mode**

U-NII	Channel	Channel Frequency (MHz)	PPSD (dBm)		PSD Total (dBm)	Limit (dBm/MHz)	Pass / Fail
			Chain 0	Chain 1			
Band 1	Low	5190	-6.00	-6.21	-3.10	7.29	PASS
	High	5230	1.44	1.58	4.52	7.29	PASS

**Remark:**

1. At final test to get the worst-case emission at 13.5Mbps.
2. The cable assembly insertion loss of 10.5 dB (including 10 dB pad and 0.5 dB cable) was Entered as an offset in the spectrum analyzer to allow for direct reading of power.
3. Total power spectral density = Chain 0 + Chain 1.
4. The directional gain is 9.71dBi which is more than 6dBi, the limit should be 7.29dBm.

**IEEE 802.11a Mode**

U-NII	Channel	Channel Frequency (MHz)	PPSD (dBm)		PSD Total (dBm)	Limit (dBm/500kHz)	Pass / Fail
			Chain 0	Chain 1			
Band 3	Low	5745	-8.39	-7.94	-5.15	26.29	PASS
	Middle	5785	1.07	1.59	4.35	26.29	PASS
	High	5825	-2.74	-2.52	0.38	26.29	PASS

**Remark:**

1. At final test to get the worst-case emission at 6Mbps.
2. The cable assembly insertion loss of 10.5 dB (including 10 dB pad and 0.5 dB cable) was Entered as an offset in the spectrum analyzer to allow for direct reading of power.
3. Total power spectral density = Chain 0 + Chain 1.
4. The directional gain is 9.71dBi which is more than 6dBi, the limit should be 26.29dBm.

**IEEE 802.11an HT20 Mode**

U-NII	Channel	Channel Frequency (MHz)	PPSD (dBm)		PSD Total (dBm)	Limit (dBm/500kHz)	Pass / Fail
			Chain 0	Chain 1			
Band 3	Low	5745	-8.59	-8.14	-5.35	29.93	PASS
	Middle	5785	1.45	2.11	4.80	29.93	PASS
	High	5825	-3.46	-3.69	-0.56	29.93	PASS

**Remark:**

1. At final test to get the worst-case emission at 6.5Mbps.
2. The cable assembly insertion loss of 10.5 dB (including 10 dB pad and 0.5 dB cable) was Entered as an offset in the spectrum analyzer to allow for direct reading of power.
3. Total power spectral density = Chain 0 + Chain 1.
4. The directional gain is 9.71dBi which is more than 6dBi, the limit should be 26.29dBm.

**IEEE 802.11an HT40 Mode**

U-NII	Channel	Channel Frequency (MHz)	PPSD (dBm)		PSD Total (dBm)	Limit (dBm/500kHz)	Pass / Fail
			Chain 0	Chain 1			
Band 3	Low	5755	-11.23	-11.11	-8.16	29.93	PASS
	High	5795	-3.23	-3.44	-0.32	29.93	PASS

**Remark:**

1. At final test to get the worst-case emission at 13.5Mbps.
2. The cable assembly insertion loss of 10.5 dB (including 10 dB pad and 0.5 dB cable) was Entered as an offset in the spectrum analyzer to allow for direct reading of power.
3. Total power spectral density = Chain 0 + Chain 1.
4. The directional gain is 9.71dBi which is more than 6dBi, the limit should be 26.29dBm.

**POWER SPECTRAL DENSITY**

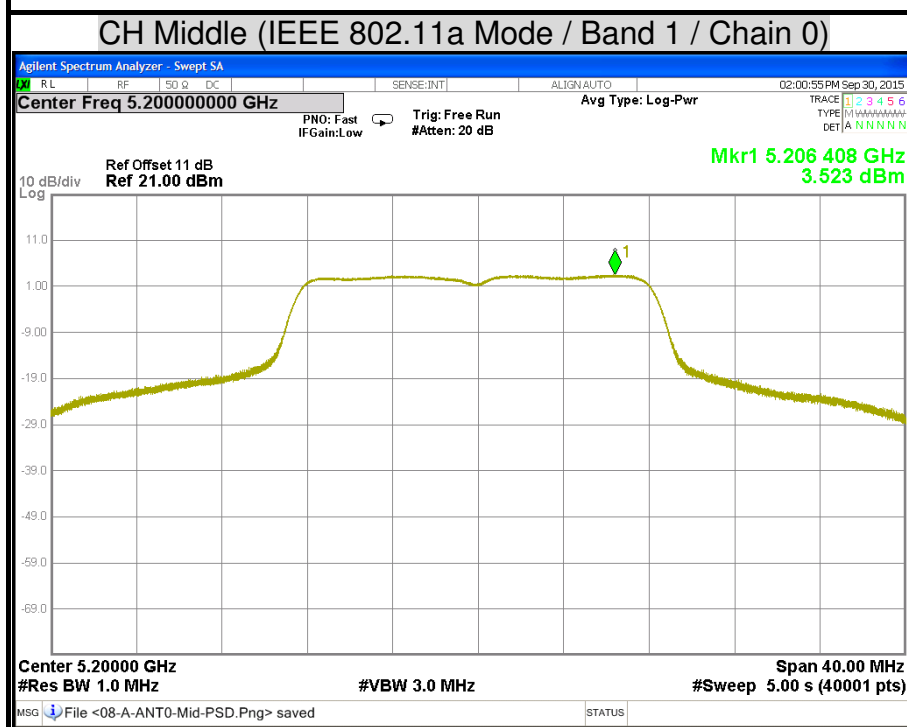
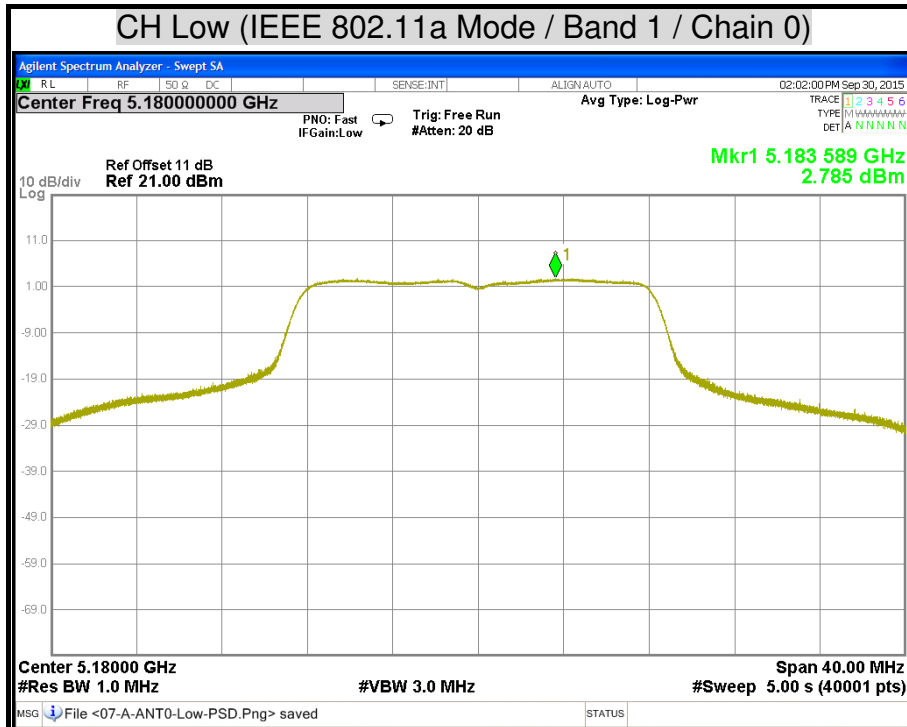

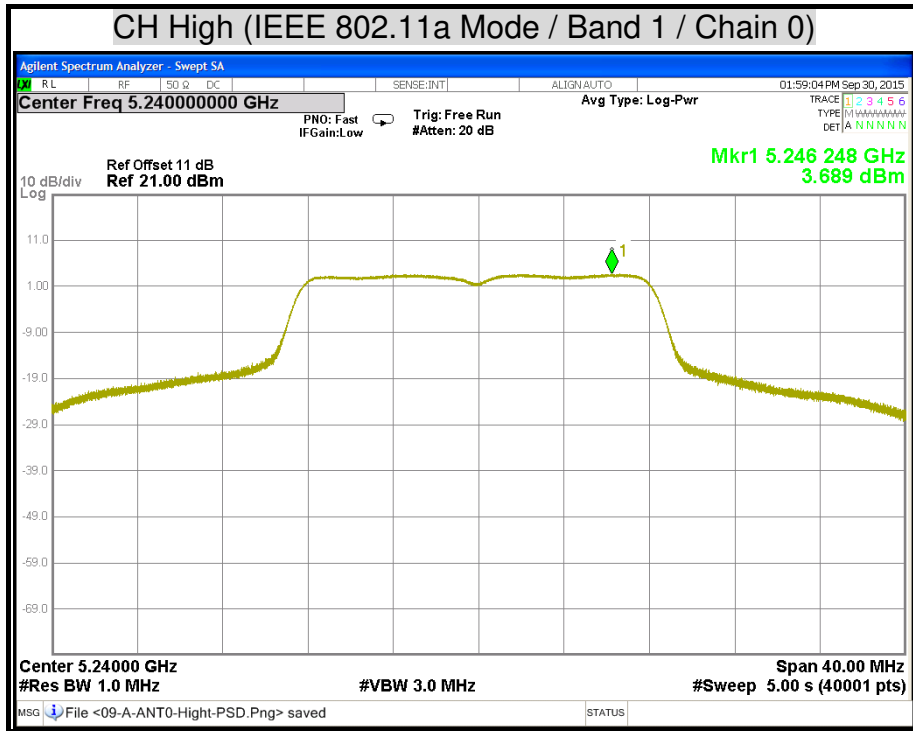

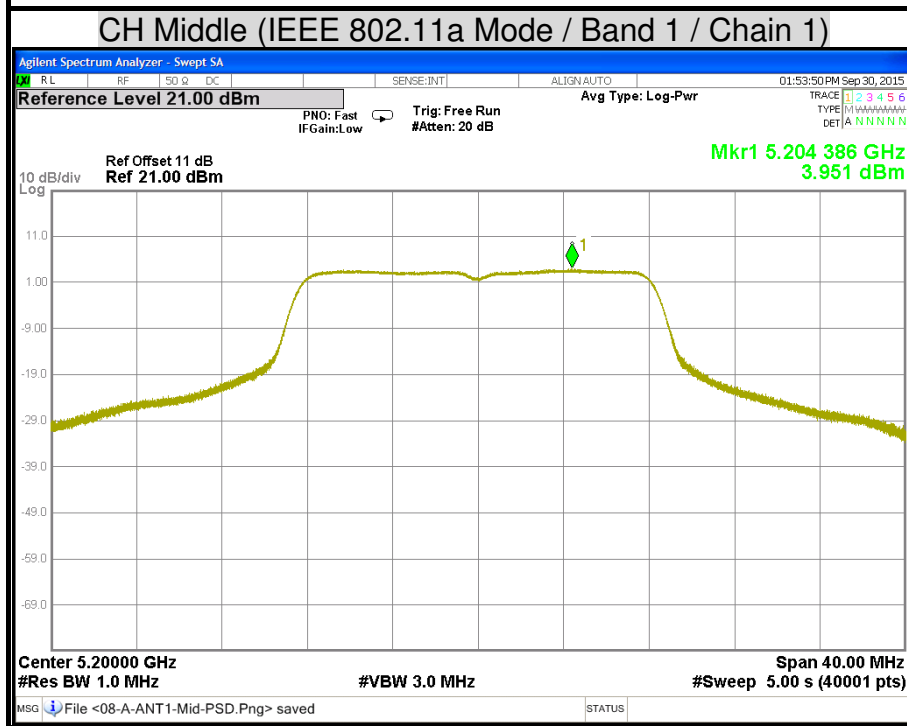
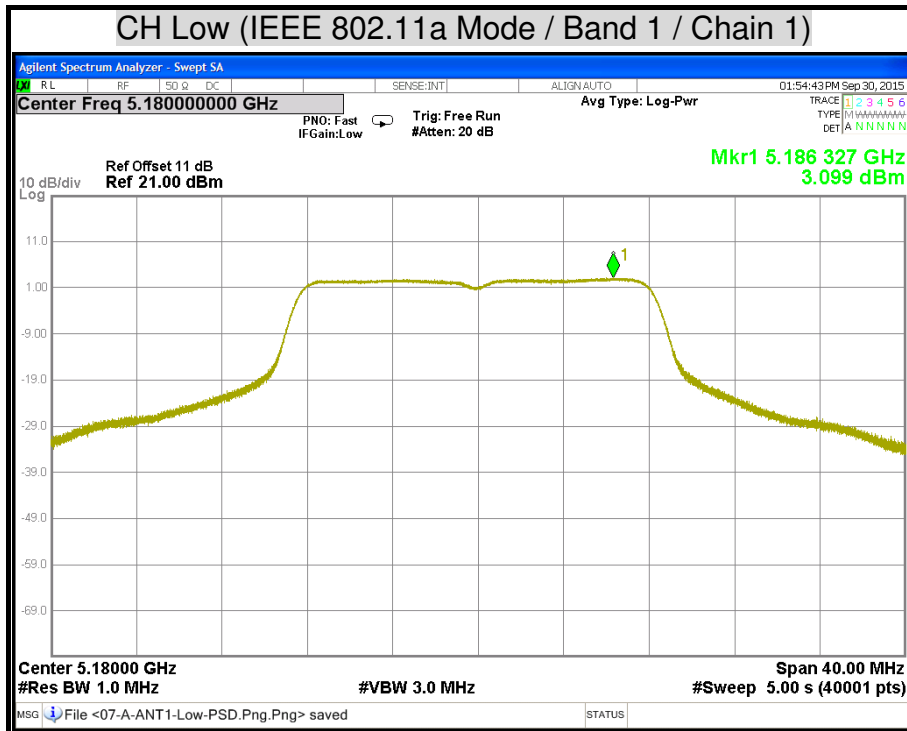

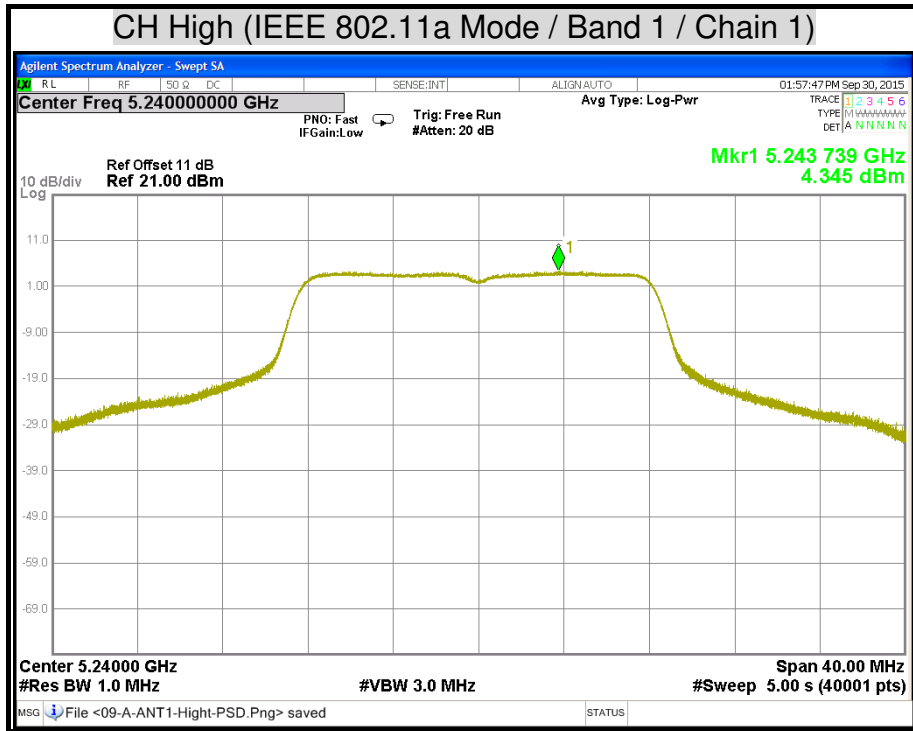

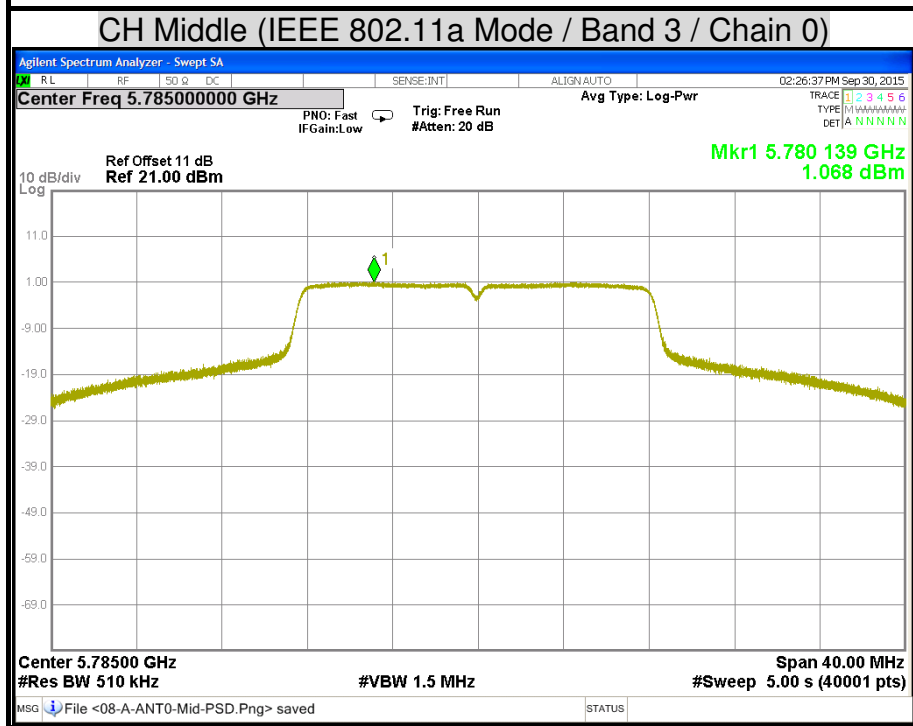
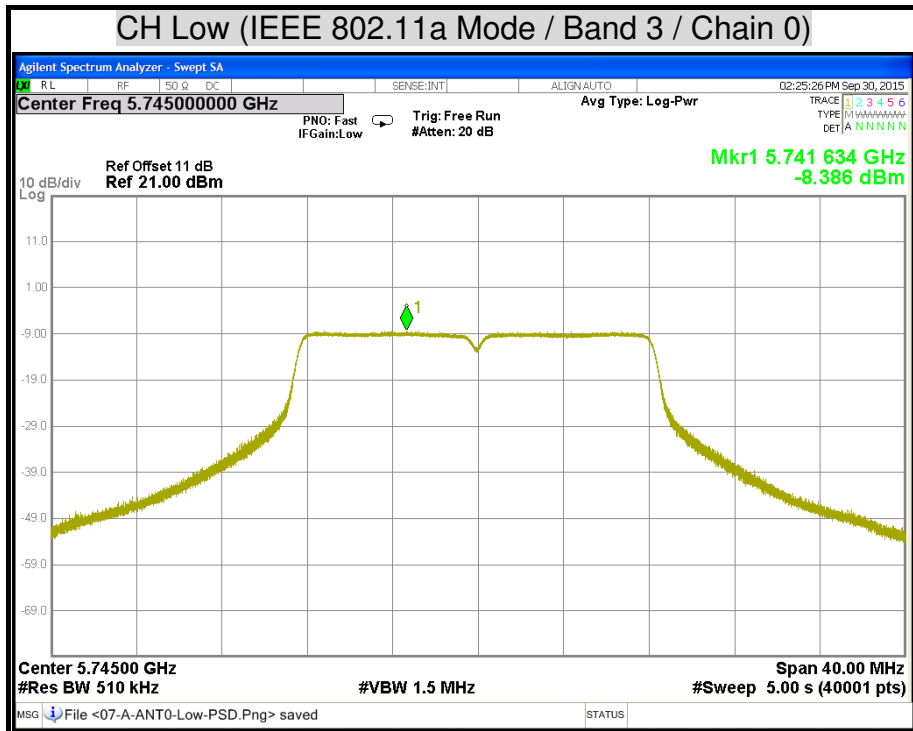



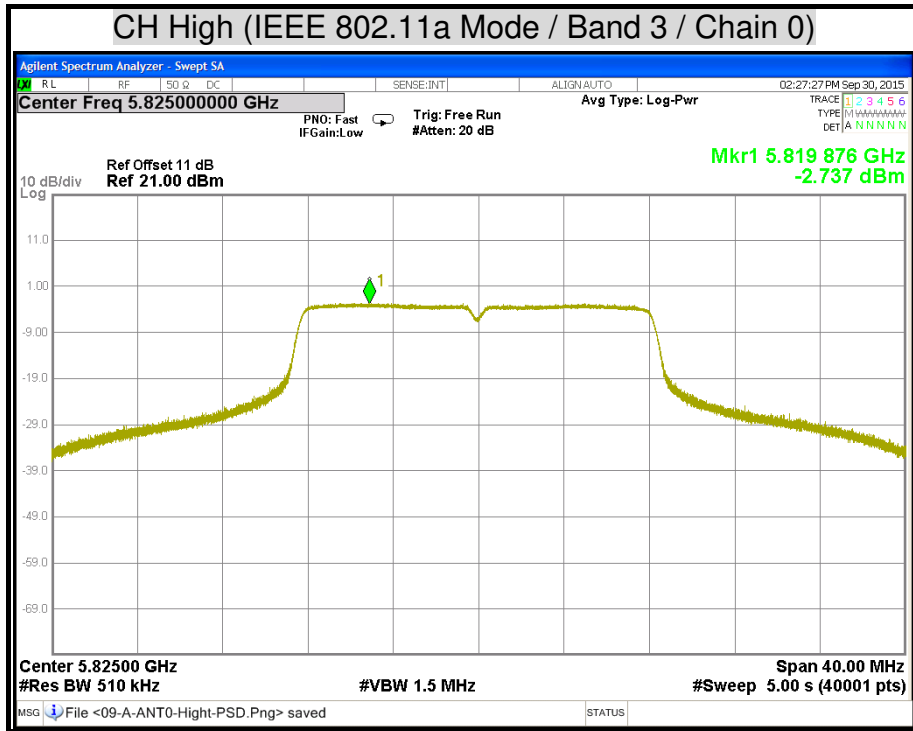

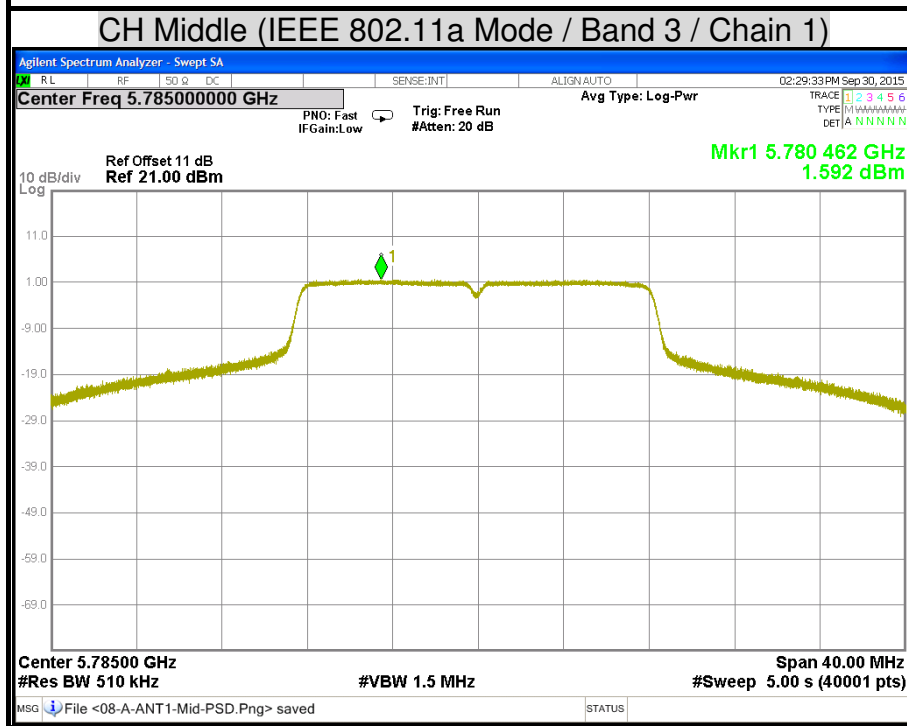
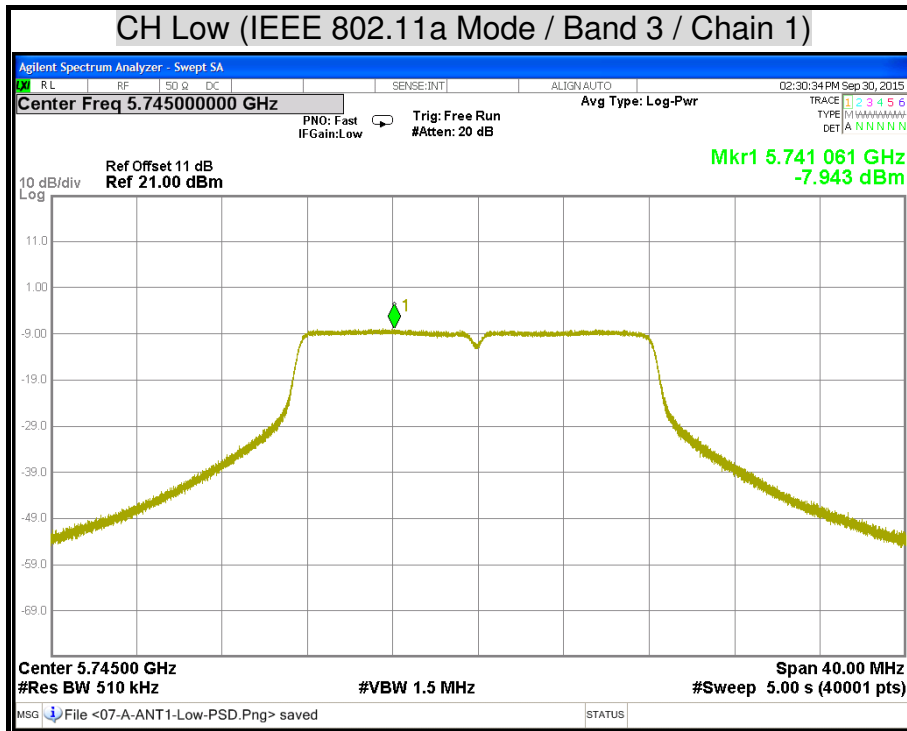

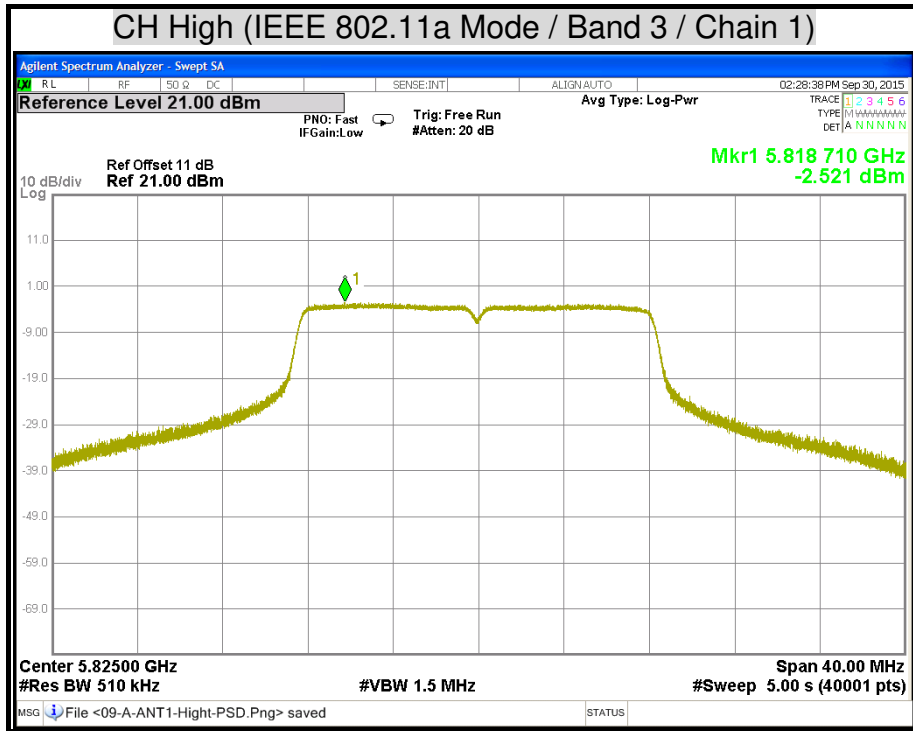

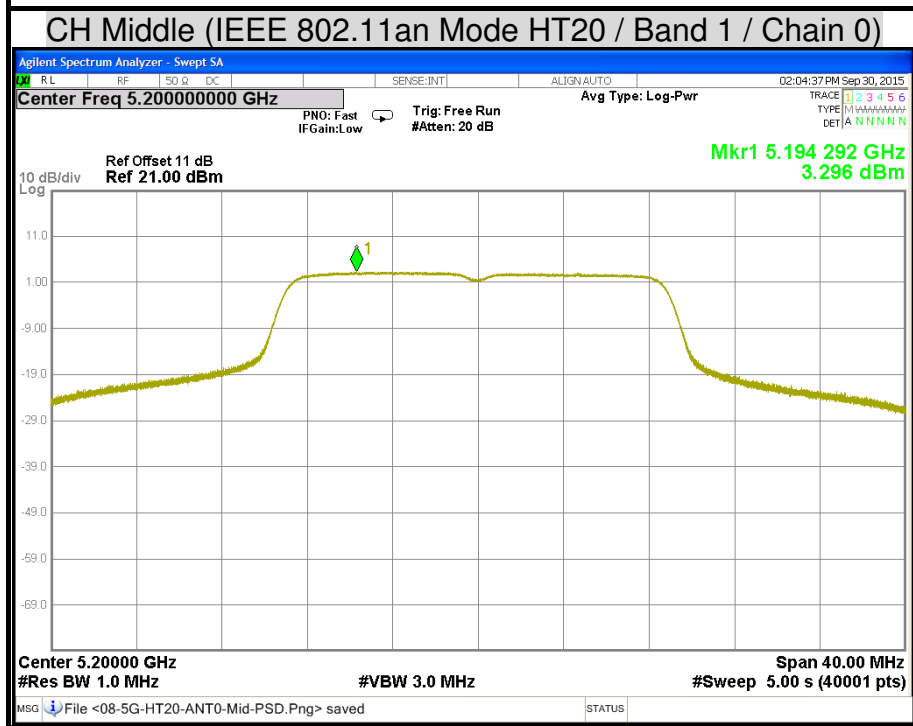
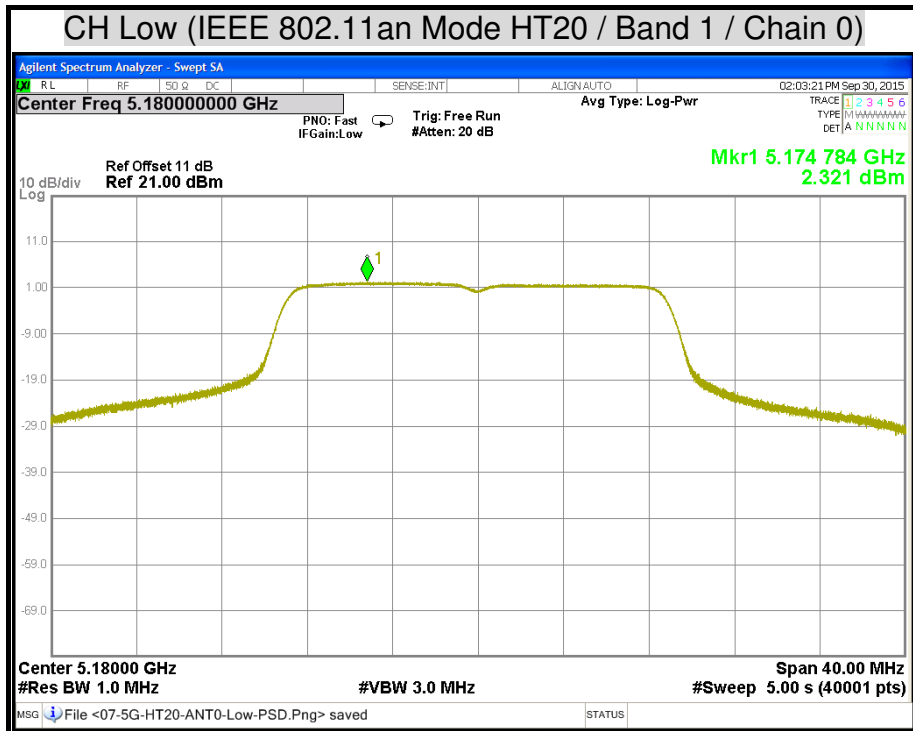

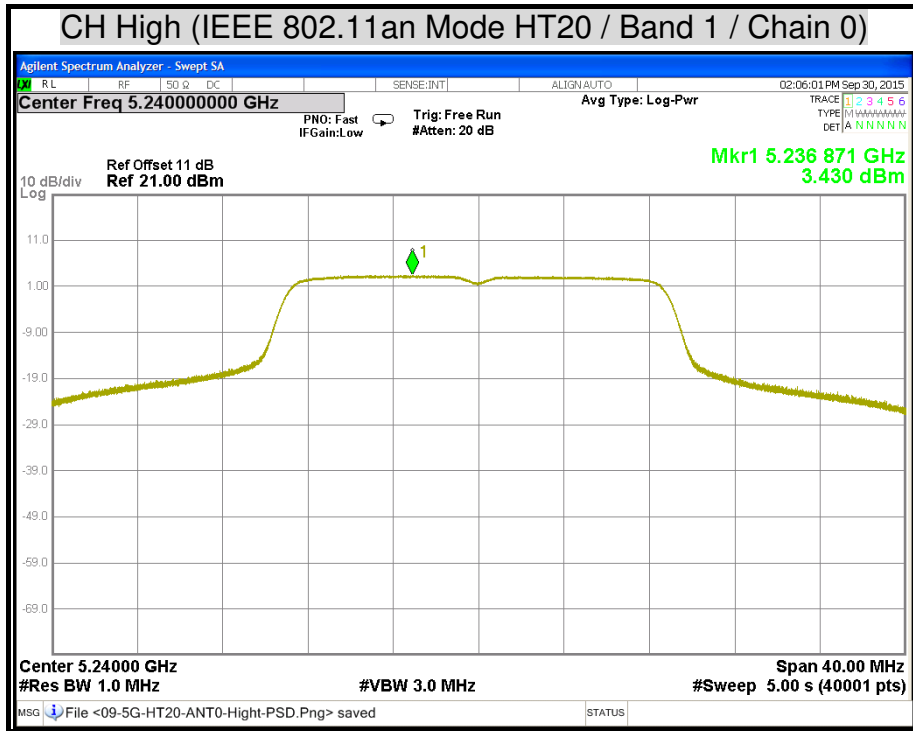

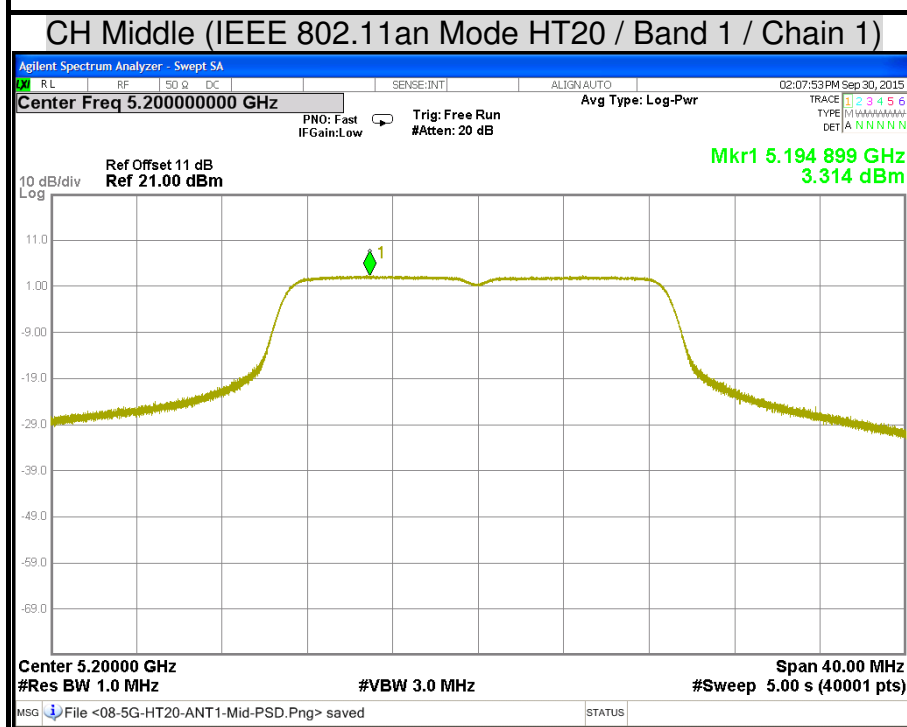
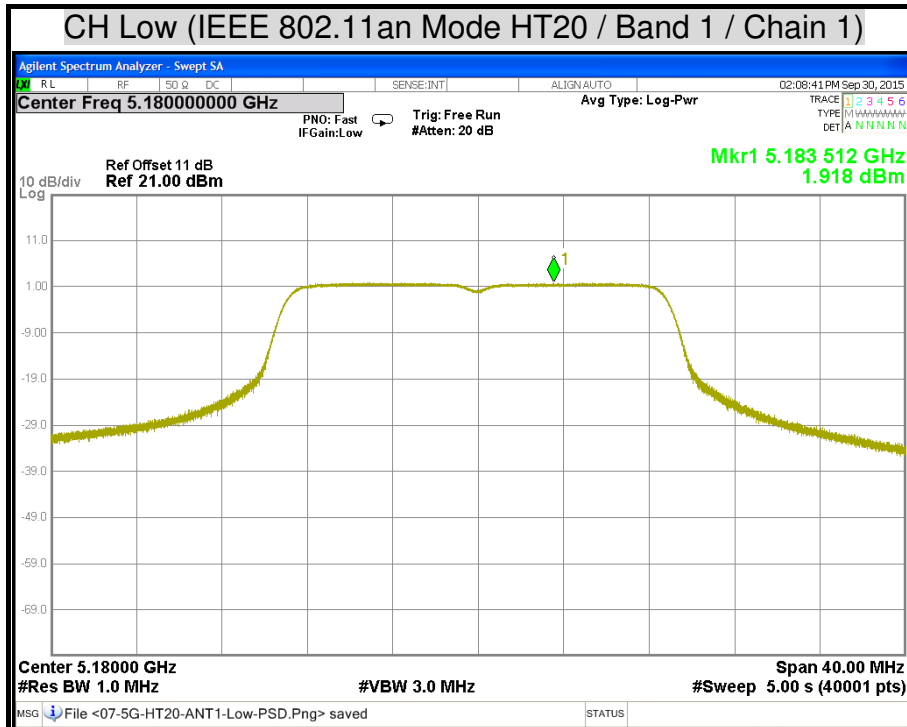

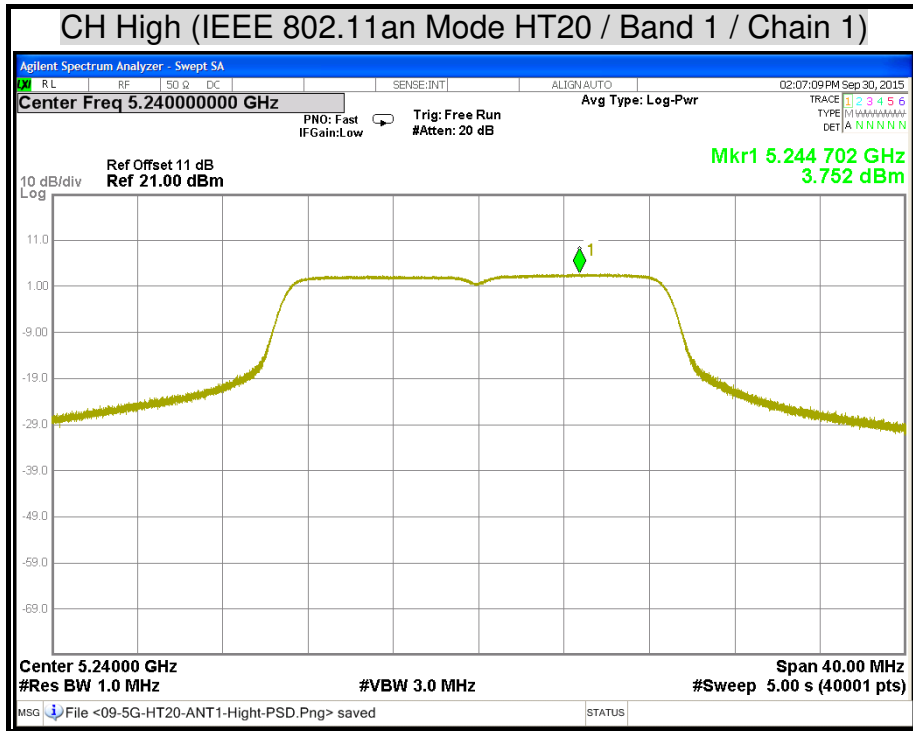

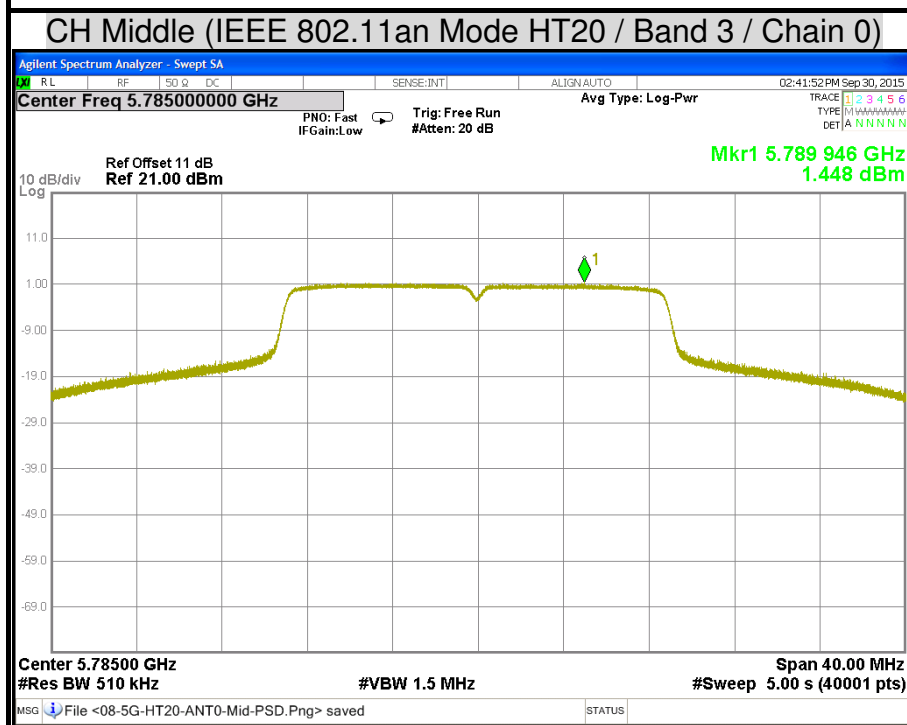
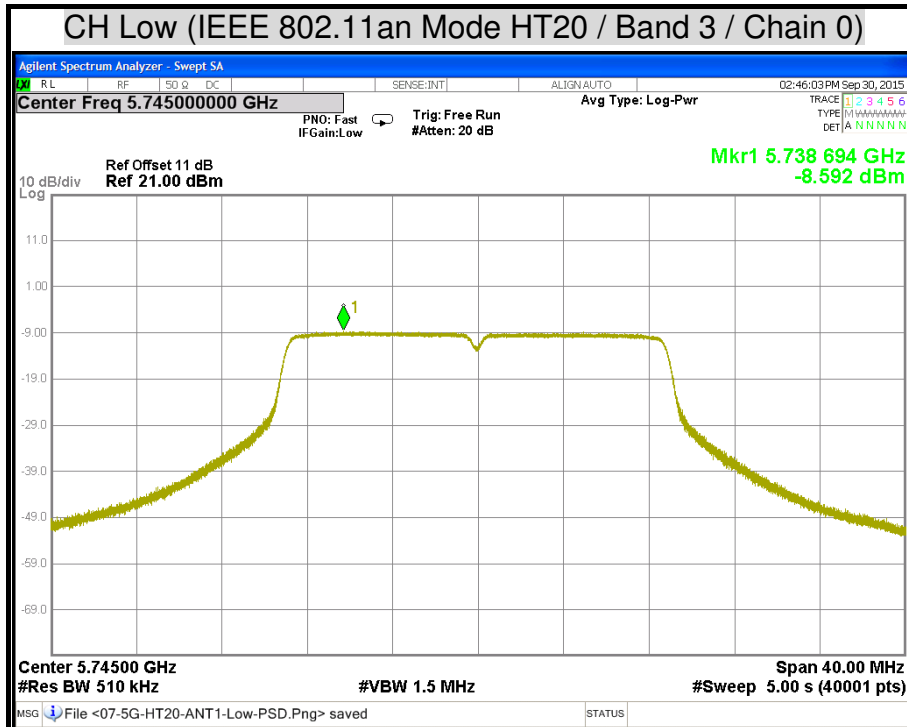



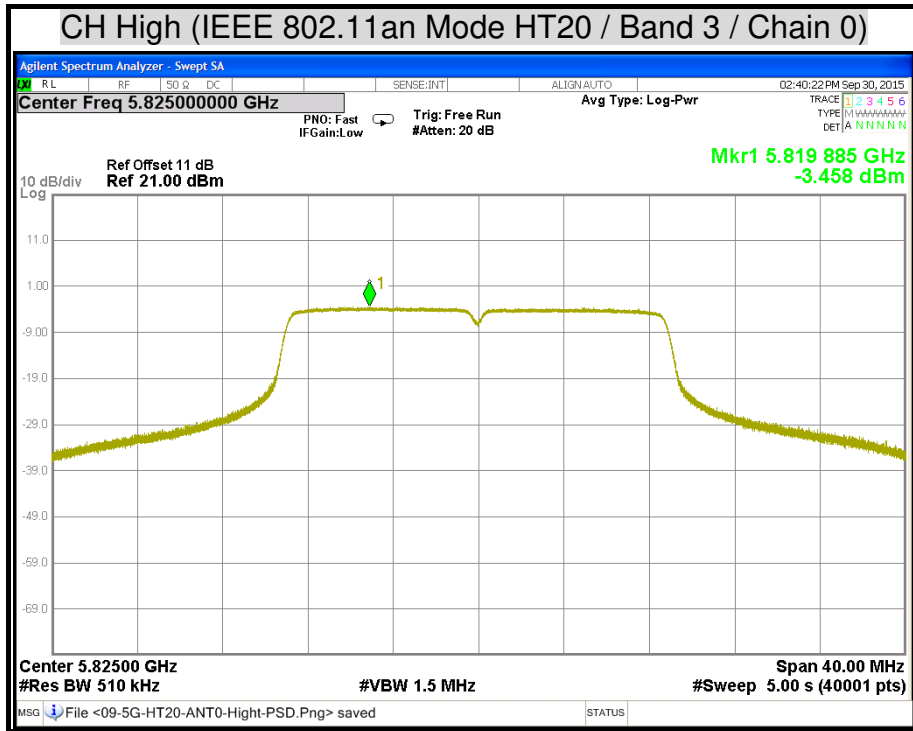

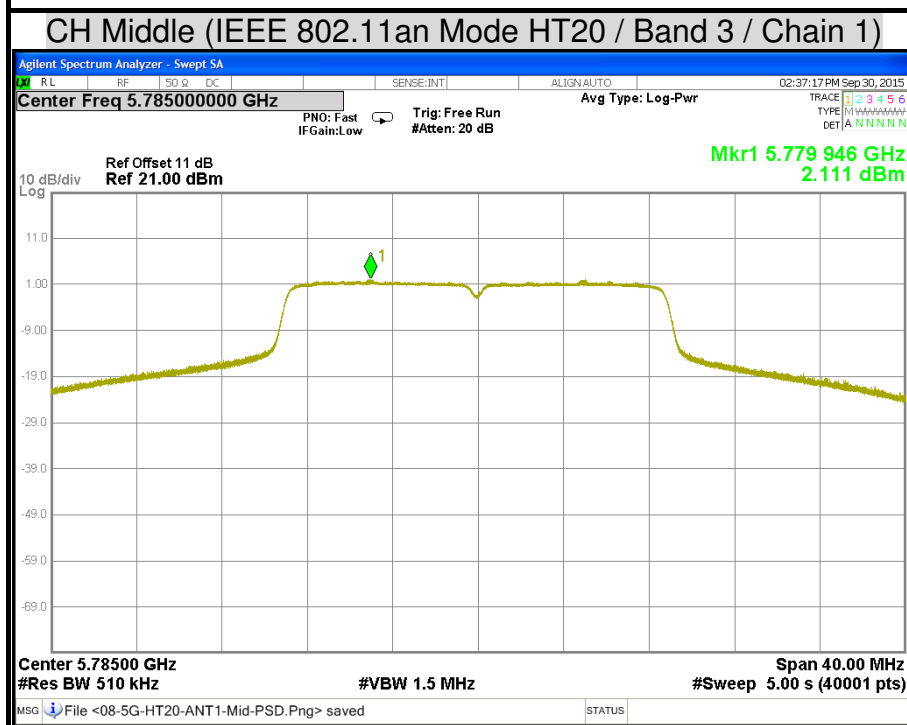
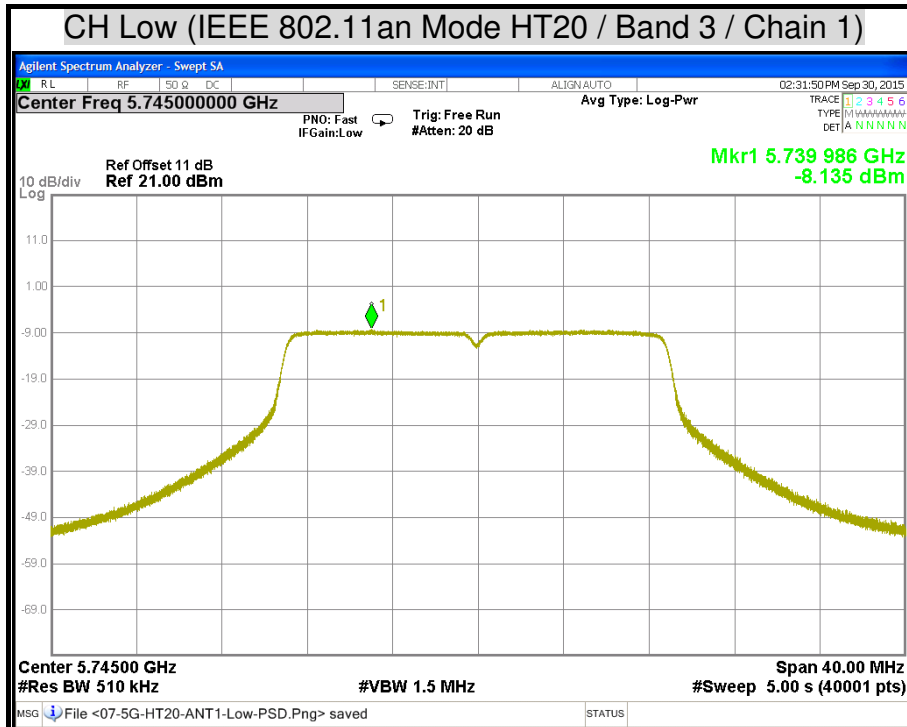

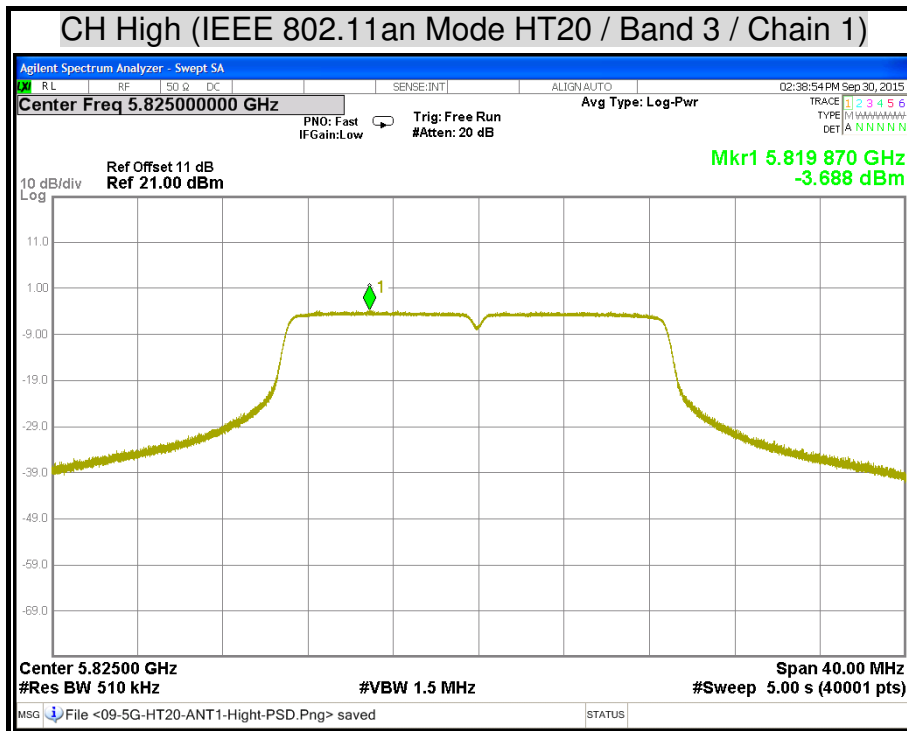

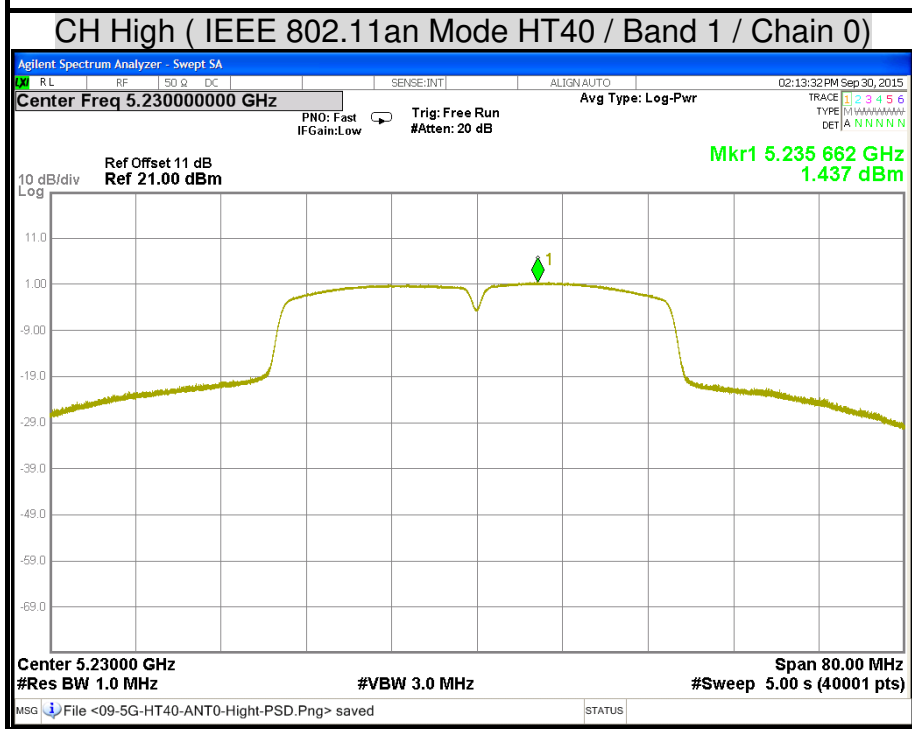
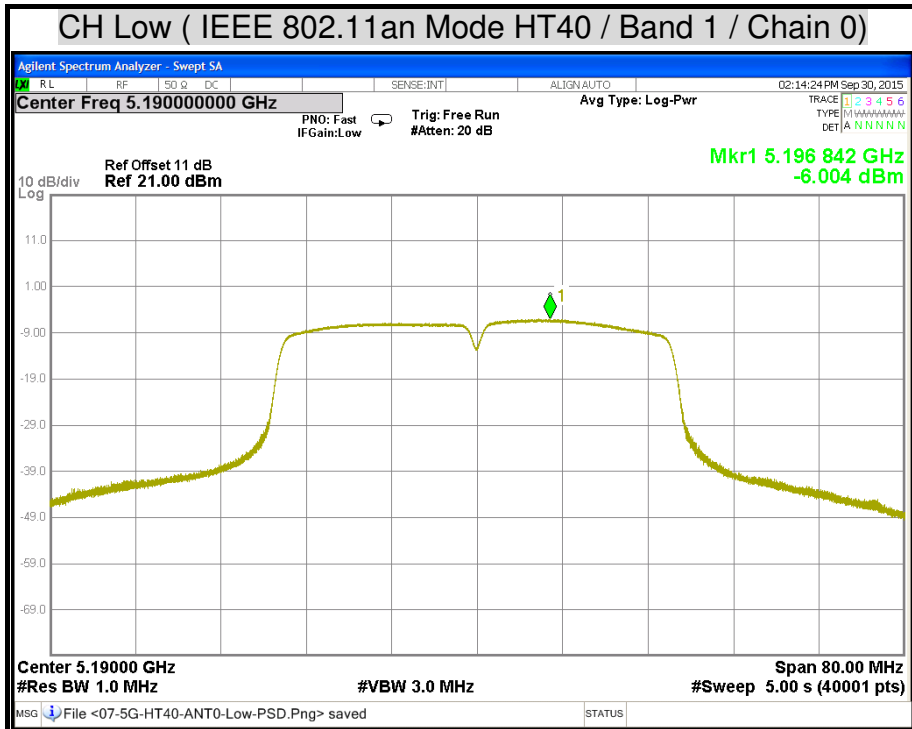

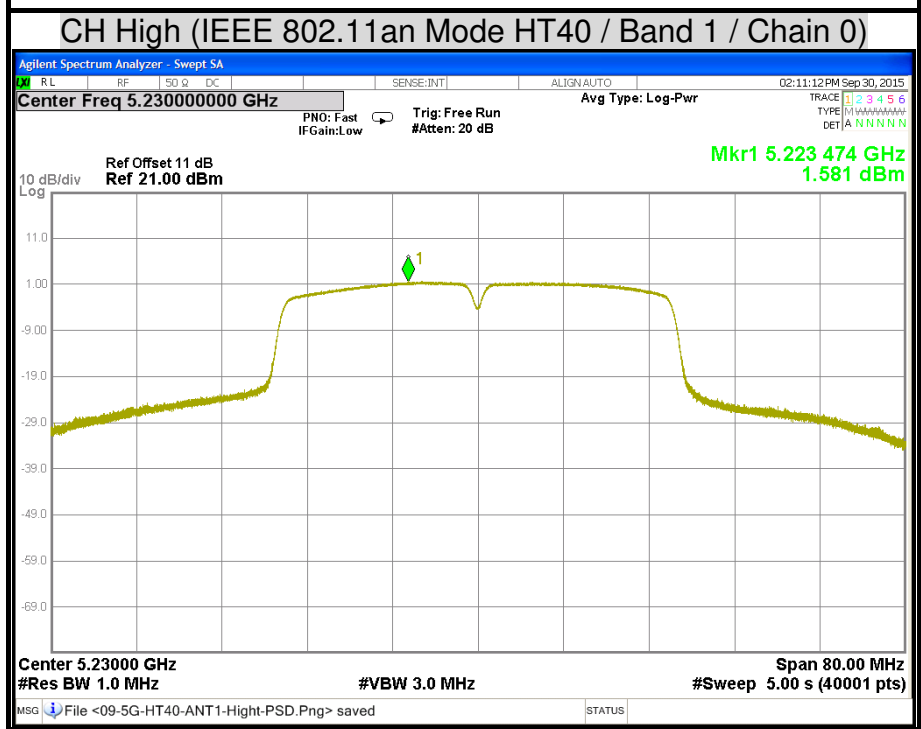
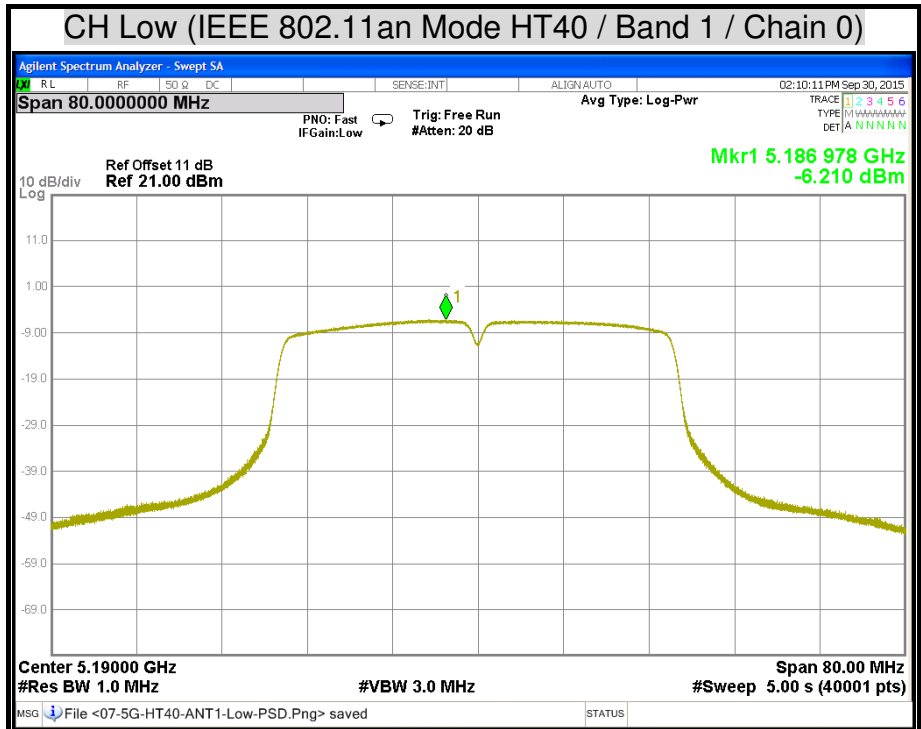

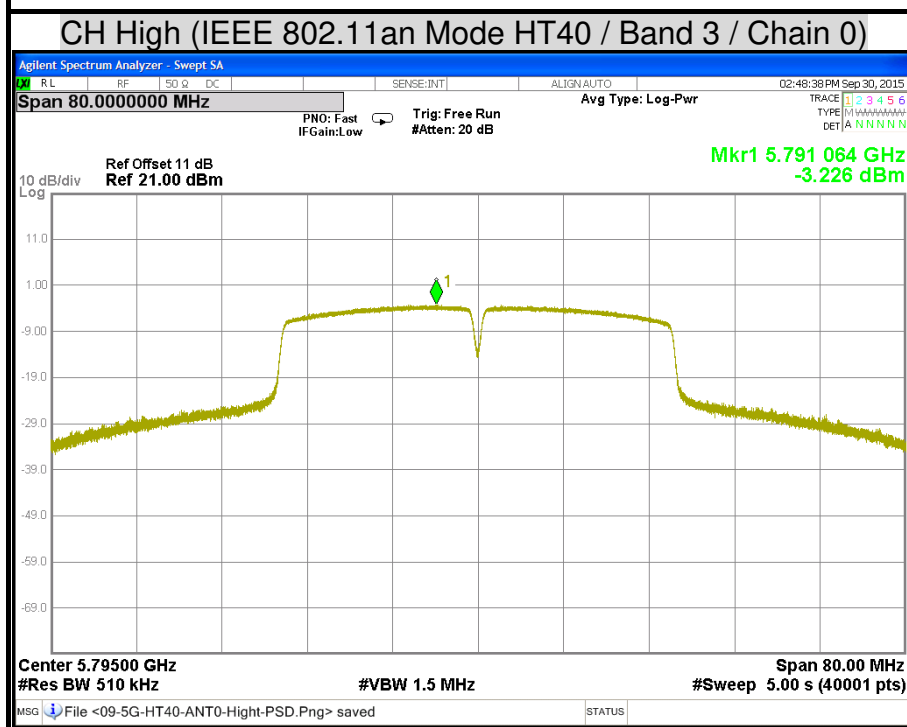
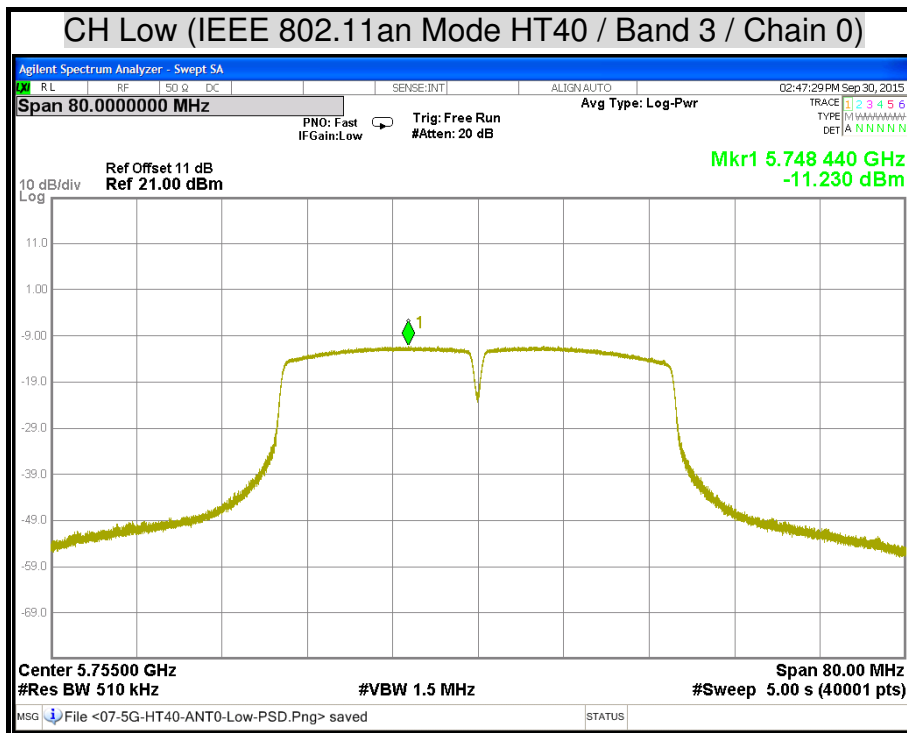

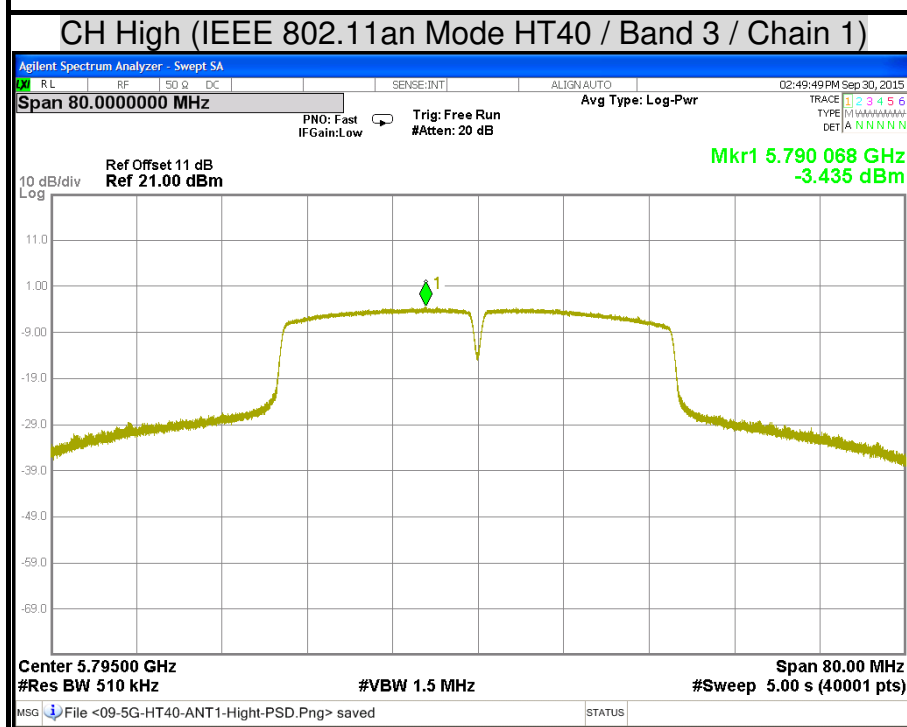
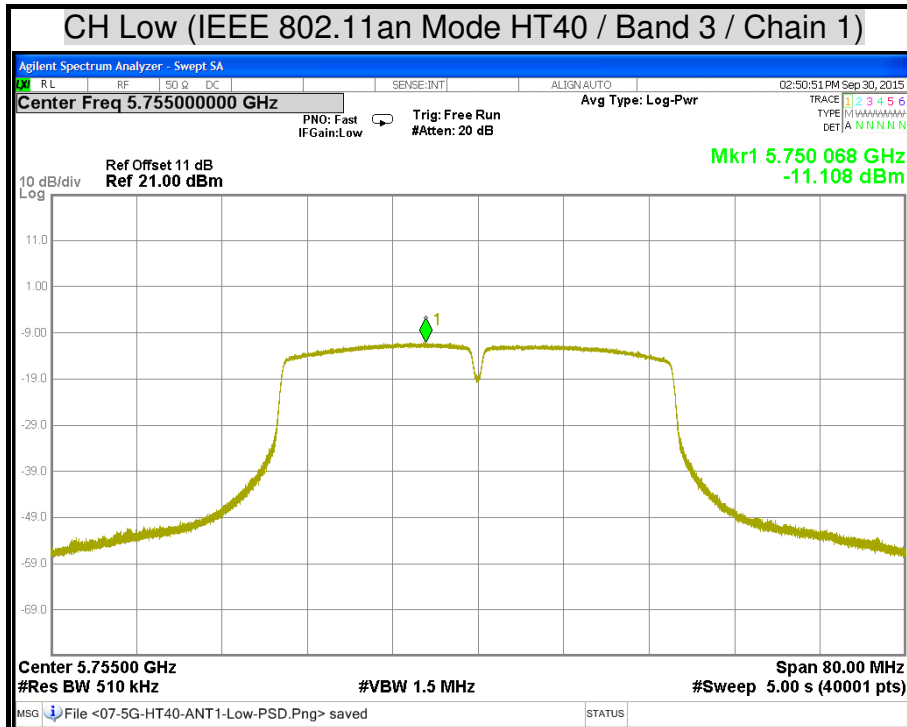

## 7.4 RADIATED EMISSION

### LIMITS

(1) According to § 15.205 (a) Except as shown in paragraph (d) of this section, only spurious emissions are permitted in any of the frequency bands listed below:

MHz	MHz	MHz	GHz
0.090 - 0.110	16.42 - 16.423	399.9 - 410	4.5 - 5.15
<sup>1</sup> 0.495 - 0.505	16.69475 - 16.69525	608 - 614	5.35 - 5.46
2.1735 - 2.1905	16.80425 - 16.80475	960 - 1240	7.25 - 7.75
4.125 - 4.128	25.5 - 25.67	1300 - 1427	8.025 - 8.5
4.17725 - 4.17775	37.5 - 38.25	1435 - 1626.5	9.0 - 9.2
4.20725 - 4.20775	73 - 74.6	1645.5 - 1646.5	9.3 - 9.5
6.215 - 6.218	74.8 - 75.2	1660 - 1710	10.6 - 12.7
6.26775 - 6.26825	108 - 121.94	1718.8 - 1722.2	13.25 - 13.4
6.31175 - 6.31225	123 - 138	2200 - 2300	14.47 - 14.5
8.291 - 8.294	149.9 - 150.05	2310 - 2390	15.35 - 16.2
8.362 - 8.366	156.52475 - 156.52525	2483.5 - 2500	17.7 - 21.4
8.37625 - 8.38675	156.7 - 156.9	2655 - 2900	22.01 - 23.12
8.41425 - 8.41475	162.0125 - 167.17	3260 - 3267	23.6 - 24.0
12.29 - 12.293	167.72 - 173.2	3332 - 3339	31.2 - 31.8
12.51975 - 12.52025	240 - 285	3345.8 - 3338	36.43 - 36.5
12.57675 - 12.57725	322 - 335.4	3600 - 4400	( <sup>2</sup> )
13.36 - 13.41			

**Remark:**

1. <sup>1</sup> Until February 1, 1999, this restricted band shall be 0.490-0.510 MHz.
2. <sup>2</sup> Above 38.6

(2) According to § 15.205 (b) Except as provided in paragraphs (d) and (e) of this section, the field strength of emissions appearing within these frequency bands shall not exceed the limits shown in §15.209. At frequencies equal to or less than 1000 MHz, compliance with the limits in §15.209 shall be demonstrated using measurement instrumentation employing a CISPR quasi-peak detector. Above 1000 MHz, compliance with the emission limits in §15.209 shall be demonstrated based on the average value of the measured emissions. The provisions in §15.35 apply to these measurements.



(3) According to § 15.209 (a) Except as provided elsewhere in this Subpart, the emissions from an intentional radiator shall not exceed the field strength levels specified in the following table :

Frequency (MHz)	Field Strength (microvolts/meter)	Measurement Distance (meters)
0.009 – 0.490	2400/F(KHz)	300
0.490 – 1.705	24000/F(KHz)	30
1.705 – 30.0	30	30
30 - 88	100 **	3
88 - 216	150 **	3
216 - 960	200 **	3
Above 960	500	3

**Remark:** \*\*Except as provided in paragraph (g), fundamental emissions from intentional radiators operating under this Section shall not be located in the frequency bands 54-72 MHz, 76-88 MHz, 174-216 MHz or 470-806 MHz. However, operation within these frequency bands is permitted under other sections of this Part, e.g., Sections 15.231 and 15.241.

(4) According to § 15.209 (b) In the emission table above, the tighter limit applies at the band edges.

**TEST EQUIPMENT**

**Radiated Emission / 966Chamber\_B**

Name of Equipment	Manufacture	Model	Serial Number	Calibration Due
Spectrum Analyzer	Agilent	E4446A	MY46180323	04/14/2016
EMI Test Receiver	Rohde & Schwarz	ESCI	100221	04/22/2016
Bi-log Antenna	TESEQ	CBL 6112D	35403	08/04/2016
Broad-Band Horn Antenna	Schwarzbeck	BBHA 9120 D	9120D-778	08/09/2016
Double-Ridged Waveguide Horn	ETS-LINDGREN	3117	00078733	12/02/2015
Horn Antenna	COM-POWER	AH-840	03077	12/17/2015
Pre-Amplifier	Agilent	8447D	2944A10052	07/14/2016
Pre-Amplifier	Agilent	8449B	3008A01916	07/14/2016
LOOP Antenna	COM-POWER	AL-130	121060	05/24/2016

**Remark:** Each piece of equipment is scheduled for calibration once a year.

**TEST SETUP**

The diagram below shows the test setup that is utilized to make the measurements for emission below 1GHz.

**9kHz ~ 30MHz**

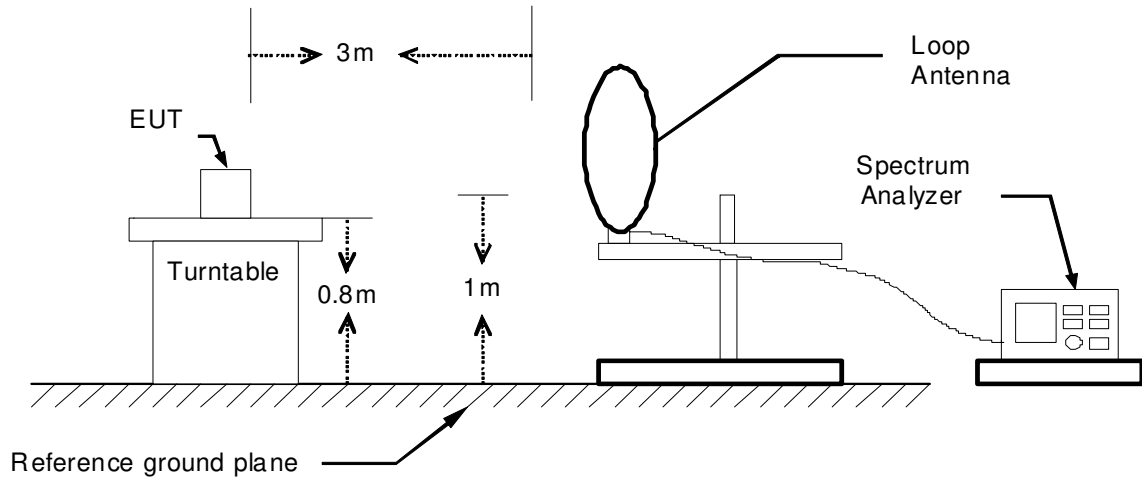

**30MHz ~ 1GHz**

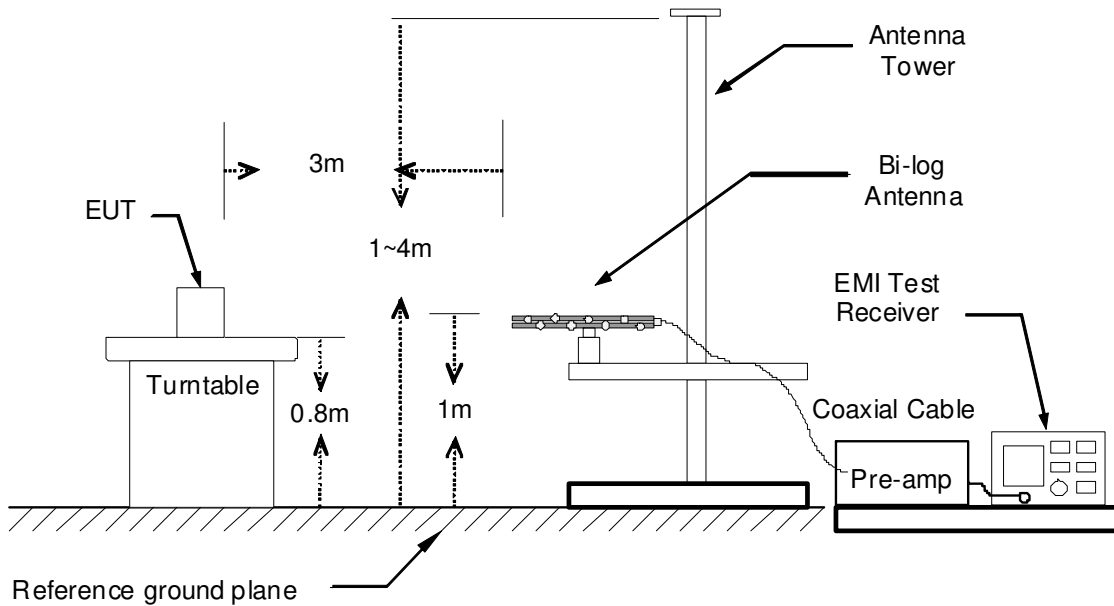

The diagram below shows the test setup that is utilized to make the measurements for emission above 1GHz.

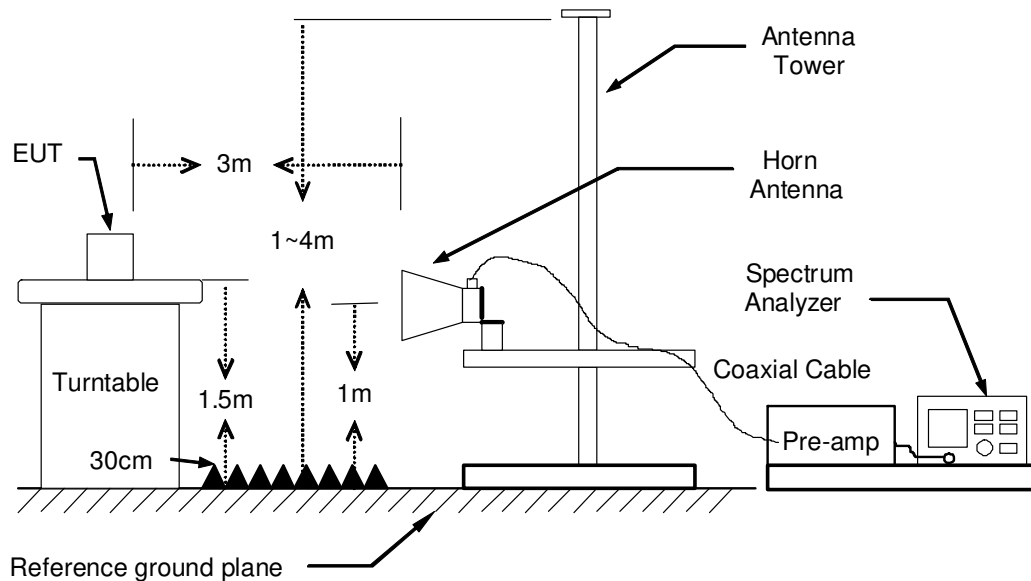

### **TEST PROCEDURE**

1. The EUT was placed on the top of a rotating table 0.8 and 1.5 meters above the ground. The table was rotated 360 degrees to determine the position of the highest radiation.
2. While measuring the radiated emission below 1GHz, the EUT was set 3 meters away from the interference-receiving antenna, which was mounted on the top of a variable-height antenna tower. While measuring the radiated emission above 1GHz, the EUT was set 3 meters away from the interference-receiving antenna.
3. The antenna is a broadband antenna, and its height is varied from one meter to four meters above the ground to determine the maximum value of the field strength. Both horizontal and vertical polarization of the antenna are set to make the measurement.
4. For each suspected emission, the EUT was arranged to its worst case and then the antenna was tuned to heights from 1 meter to 4 meters and the table was turned from 0 degrees to 360 degrees to find the maximum reading.
5. The test-receiver system was set to Peak Detect Function and Specified Bandwidth with Maximum Hold Mode.
6. If the emission level of the EUT in peak mode was 10 dB lower than the limit specified, then testing could be stopped and the peak values of the EUT would be reported. Otherwise the emissions that did not have 10 dB margin would be re-tested one by one using peak, quasi-peak or average method as specified and then reported in a data sheet.

#### **Remark :**

1. The resolution bandwidth and video bandwidth of test receiver/spectrum analyzer is 120 KHz for Peak detection (PK) and Quasi-peak detection (QP) at frequency below 1GHz.
2. The resolution bandwidth and video bandwidth of test receiver/spectrum analyzer is 1 MHz for Peak detection and frequency above 1GHz.
3. The resolution bandwidth of test receiver/spectrum analyzer is 1 MHz and the video bandwidth is 10 Hz for Average detection (AV) at frequency above 1GHz.

**TEST RESULTS**

**Below 1 GHz (9kHz ~ 30MHz)**

No emission found between lowest internal used/generated frequency to 30MHz.

**Below 1 GHz (30MHz ~ 1GHz)**

<b>Product Name</b>	All In One Panel PC	<b>Test By</b>	Rex Chiu
<b>Test Model</b>	3365-199	<b>Test Date</b>	2015/09/15
<b>Test Mode</b>	TX Mode	<b>Temp. &amp; Humidity</b>	25°C, 50%

**966Chamber\_B at 3Meter / Horizontal**

Freq. MHz	Reading dBuV	C.F. dB/m	Result dBuV/m	Limit dBuV/m	Margin dB	Azimuth deg	Height cm	Remark
102.75	48.58	-15.42	33.16	43.50	-10.34	106	200	Peak
178.41	55.92	-16.59	39.33	43.50	-4.17	96	200	Peak
250.19	50.47	-12.67	37.80	46.00	-8.20	247	100	Peak
341.37	48.98	-10.45	38.53	46.00	-7.47	141	100	Peak
427.70	41.93	-8.89	33.04	46.00	-12.96	155	200	Peak
666.32	40.86	-5.99	34.87	46.00	-11.13	314	100	Peak
940.83	39.14	-2.52	36.62	46.00	-9.38	134	100	Peak

**966Chamber\_B at 3Meter / Vertical**

Freq. MHz	Reading dBuV	C.F. dB/m	Result dBuV/m	Limit dBuV/m	Margin dB	Azimuth deg	Height cm	Remark
31.94	44.24	-9.24	35.00	40.00	-5.00	350	100	Peak
46.49	52.08	-17.75	34.33	40.00	-5.67	58	100	Peak
115.36	48.62	-14.53	34.09	43.50	-9.41	120	100	Peak
177.44	53.79	-16.56	37.23	43.50	-6.27	82	100	Peak
427.70	41.31	-8.89	32.42	46.00	-13.58	333	100	Peak
500.45	41.07	-8.13	32.94	46.00	-13.06	269	100	Peak
940.83	38.62	-2.52	36.10	46.00	-9.90	126	100	Peak

**Remark:**

1. Quasi-peak test would be performed if the peak result were greater than the quasi-peak limit.
2. Correction Factor (dB/m) = Antenna Factor (dB/m) + Cable Loss (dB) – PreAmp.Gain (dB)
3. Result (dBuV/m) = Reading (dBuV) + Correction Factor (dB/m)
4. Margin (dB) = Remark result (dBuV/m) - Quasi-peak limit (dBuV/m).

**Above 1 GHz**

<b>Product Name</b>	All In One Panel PC	<b>Test By</b>	Rex Chiu
<b>Test Model</b>	3365-199	<b>Test Date</b>	2015/09/14
<b>Test Mode</b>	UNII Band 1 / IEEE 802.11a TX / CH Low	<b>Temp. &amp; Humidity</b>	25°C, 50%

**966Chamber\_B at 3Meter / Horizontal**

Freq. MHz	Reading dBuV	C.F. dB/m	Result dBuV/m	Limit dBuV/m	Margin dB	Azimuth deg	Height cm	Remark
2995.00	47.49	4.13	51.62	74.00	-22.38	251	100	Peak
5350.00	38.24	9.46	47.70	74.00	-26.30	316	200	Peak
5975.00	40.33	10.81	51.14	74.00	-22.86	252	200	Peak
7008.00	36.89	12.25	49.14	74.00	-24.86	66	100	Peak
8568.00	36.56	13.21	49.77	74.00	-24.23	69	200	Peak
10368.00	28.50	16.43	44.93	54.00	-9.07	218	100	Average
10368.00	37.29	16.43	53.72	74.00	-20.28	218	100	Peak

**966Chamber\_B at 3Meter / Vertical**

Freq. MHz	Reading dBuV	C.F. dB/m	Result dBuV/m	Limit dBuV/m	Margin dB	Azimuth deg	Height cm	Remark
4655.00	41.72	8.01	49.73	74.00	-24.27	283	100	Peak
5360.00	40.79	9.48	50.27	74.00	-23.73	230	200	Peak
5980.00	40.73	10.82	51.55	74.00	-22.45	215	100	Peak
6984.00	36.88	12.23	49.11	74.00	-24.89	149	200	Peak
8724.00	37.06	13.22	50.28	74.00	-23.72	66	200	Peak
10356.00	28.80	16.40	45.20	54.00	-8.80	262	200	Average
10356.00	37.70	16.40	54.10	74.00	-19.90	262	200	Peak

**Remark:**

1. Measuring frequencies from 1 GHz to the 10th harmonic of highest fundamental frequency.
2. Average test would be performed if the peak result were greater than the average limit.
3. Measurements above show only up to 6 maximum emissions noted, or would be lesser, with " N/A " remark, if no specific emissions from the EUT are recorded (ie: margin>20dB from the applicable limit) and considered that's already beyond the background noise floor.
4. Result = Reading + Correction Factor  
 Margin = Result - Limit  
 Remark Peak = Result(PK) - Limit(PK)  
 Remark AVG = Result(AV) - Limit(AV)

<b>Product Name</b>	All In One Panel PC	<b>Test By</b>	Rex Chiu
<b>Test Model</b>	3365-199	<b>Test Date</b>	2015/09/14
<b>Test Mode</b>	UNII Band 1 / IEEE 802.11a TX / CH Middle	<b>Temp. &amp; Humidity</b>	25°C, 50%

**966Chamber\_B at 3Meter / Horizontal**

Freq. MHz	Reading dBuV	C.F. dB/m	Result dBuV/m	Limit dBuV/m	Margin dB	Azimuth deg	Height cm	Remark
2995.00	46.58	4.13	50.71	74.00	-23.29	246	100	Peak
5150.00	38.13	9.10	47.23	74.00	-26.77	211	100	Peak
5350.00	37.69	9.46	47.15	74.00	-26.85	285	100	Peak
5980.00	41.07	10.82	51.89	74.00	-22.11	170	100	Peak
7008.00	37.46	12.25	49.71	74.00	-24.29	72	100	Peak
8544.00	36.98	13.20	50.18	74.00	-23.82	138	200	Peak
10392.00	28.80	16.50	45.30	54.00	-8.70	260	100	Average
10392.00	37.63	16.50	54.13	74.00	-19.87	260	100	Peak

**966Chamber\_B at 3Meter / Vertical**

Freq. MHz	Reading dBuV	C.F. dB/m	Result dBuV/m	Limit dBuV/m	Margin dB	Azimuth deg	Height cm	Remark
5150.00	36.02	9.10	45.12	54.00	-8.88	258	200	Average
5150.00	50.02	9.10	59.12	74.00	-14.88	242	200	Peak
5350.00	40.05	9.46	49.51	74.00	-24.49	208	100	Peak
5510.00	41.72	9.76	51.48	74.00	-22.52	230	200	Peak
5975.00	40.40	10.81	51.21	74.00	-22.79	212	200	Peak
7200.00	38.11	12.30	50.41	74.00	-23.59	175	200	Peak
8664.00	37.33	13.22	50.55	74.00	-23.45	218	100	Peak
10404.00	29.80	16.53	46.33	54.00	-7.67	212	200	Average
10404.00	38.70	16.53	55.23	74.00	-18.77	212	200	Peak

**Remark:**

1. Measuring frequencies from 1 GHz to the 10th harmonic of highest fundamental frequency.
2. Average test would be performed if the peak result were greater than the average limit.
3. Measurements above show only up to 6 maximum emissions noted, or would be lesser, with " N/A " remark, if no specific emissions from the EUT are recorded (ie: margin>20dB from the applicable limit) and considered that's already beyond the background noise floor.
4. Result = Reading + Correction Factor  
 Margin = Result - Limit  
 Remark Peak = Result(PK) - Limit(PK)  
 Remark AVG = Result(AV) - Limit(AV)

<b>Product Name</b>	All In One Panel PC	<b>Test By</b>	Rex Chiu
<b>Test Model</b>	3365-199	<b>Test Date</b>	2015/09/14
<b>Test Mode</b>	UNII Band 1 / IEEE 802.11a TX / CH High	<b>Temp. &amp; Humidity</b>	25°C, 50%

**966Chamber\_B at 3Meter / Horizontal**

Freq. MHz	Reading dBuV	C.F. dB/m	Result dBuV/m	Limit dBuV/m	Margin dB	Azimuth deg	Height cm	Remark
3000.00	47.00	4.14	51.14	74.00	-22.86	242	100	Peak
3495.00	43.42	4.62	48.04	74.00	-25.96	244	100	Peak
5150.00	37.91	9.10	47.01	74.00	-26.99	332	200	Peak
5355.00	38.85	9.47	48.32	74.00	-25.68	0	200	Peak
5770.00	38.07	10.35	48.42	74.00	-25.58	114	200	Peak
6000.00	40.29	10.87	51.16	74.00	-22.84	251	200	Peak
7260.00	38.01	12.32	50.33	74.00	-23.67	229	100	Peak
8640.00	36.27	13.21	49.48	74.00	-24.52	172	100	Peak
10476.00	28.30	16.72	45.02	54.00	-8.98	260	100	Average
10476.00	37.07	16.72	53.79	74.00	-20.21	260	100	Peak

**966Chamber\_B at 3Meter / Vertical**

Freq. MHz	Reading dBuV	C.F. dB/m	Result dBuV/m	Limit dBuV/m	Margin dB	Azimuth deg	Height cm	Remark
4980.00	41.36	8.77	50.13	74.00	-23.87	242	100	Peak
5150.00	39.41	9.10	48.51	74.00	-25.49	236	200	Peak
5350.00	40.50	9.46	49.96	74.00	-24.04	218	200	Peak
5520.00	40.88	9.79	50.67	74.00	-23.33	250	200	Peak
5985.00	41.29	10.84	52.13	74.00	-21.87	175	200	Peak
6984.00	36.67	12.23	48.90	74.00	-25.10	42	100	Peak
8784.00	37.86	13.23	51.09	74.00	-22.91	360	200	Peak
10476.00	28.70	16.72	45.42	54.00	-8.58	251	100	Average
10476.00	37.46	16.72	54.18	74.00	-19.82	251	100	Peak

**Remark:**

1. Measuring frequencies from 1 GHz to the 10th harmonic of highest fundamental frequency.
2. Average test would be performed if the peak result were greater than the average limit.
3. Measurements above show only up to 6 maximum emissions noted, or would be lesser, with " N/A " remark, if no specific emissions from the EUT are recorded (ie: margin>20dB from the applicable limit) and considered that's already beyond the background noise floor.
4. Result = Reading + Correction Factor  
 Margin = Result - Limit  
 Remark Peak = Result(PK) - Limit(PK)  
 Remark AVG = Result(AV) - Limit(AV)

<b>Product Name</b>	All In One Panel PC	<b>Test By</b>	Rex Chiu
<b>Test Model</b>	3365-199	<b>Test Date</b>	2015/09/14
<b>Test Mode</b>	UNII Band 1 / IEEE 802.11an HT20 TX / CH Low	<b>Temp. &amp; Humidity</b>	25°C, 50%

**966Chamber\_B at 3Meter / Horizontal**

Freq. MHz	Reading dBuV	C.F. dB/m	Result dBuV/m	Limit dBuV/m	Margin dB	Azimuth deg	Height cm	Remark
3000.00	46.92	4.14	51.06	74.00	-22.94	251	100	Peak
4040.00	42.22	6.52	48.74	74.00	-25.26	337	100	Peak
5405.00	39.89	9.57	49.46	74.00	-24.54	94	100	Peak
6000.00	40.36	10.87	51.23	74.00	-22.77	223	200	Peak
7236.00	37.23	12.31	49.54	74.00	-24.46	72	200	Peak
8532.00	36.65	13.20	49.85	74.00	-24.15	129	200	Peak
10356.00	28.10	16.40	44.50	54.00	-9.50	4	200	Average
10356.00	36.89	16.40	53.29	74.00	-20.71	4	200	Peak

**966Chamber\_B at 3Meter / Vertical**

Freq. MHz	Reading dBuV	C.F. dB/m	Result dBuV/m	Limit dBuV/m	Margin dB	Azimuth deg	Height cm	Remark
4415.00	41.33	7.44	48.77	74.00	-25.23	177	200	Peak
5360.00	40.99	9.48	50.47	74.00	-23.53	225	200	Peak
5985.00	41.02	10.84	51.86	74.00	-22.14	220	100	Peak
6876.00	37.31	12.12	49.43	74.00	-24.57	287	200	Peak
8196.00	37.09	13.11	50.20	74.00	-23.80	328	100	Peak
10356.00	29.20	16.40	45.60	54.00	-8.40	259	200	Average
10356.00	38.10	16.40	54.50	74.00	-19.50	259	200	Peak

**Remark:**

1. Measuring frequencies from 1 GHz to the 10th harmonic of highest fundamental frequency.
2. Average test would be performed if the peak result were greater than the average limit.
3. Measurements above show only up to 6 maximum emissions noted, or would be lesser, with " N/A " remark, if no specific emissions from the EUT are recorded (ie: margin>20dB from the applicable limit) and considered that's already beyond the background noise floor.
4. Result = Reading + Correction Factor  
 Margin = Result – Limit  
 Remark Peak = Result(PK) – Limit(PK)  
 Remark AVG = Result(AV) – Limit(AV)



<b>Product Name</b>	All In One Panel PC	<b>Test By</b>	Rex Chiu
<b>Test Model</b>	3365-199	<b>Test Date</b>	2015/09/14
<b>Test Mode</b>	UNII Band 1 / IEEE 802.11an HT20 TX / CH Middle	<b>Temp. &amp; Humidity</b>	25°C, 50%

**966Chamber\_B at 3Meter / Horizontal**

Freq. MHz	Reading dBuV	C.F. dB/m	Result dBuV/m	Limit dBuV/m	Margin dB	Azimuth deg	Height cm	Remark
3000.00	48.13	4.14	52.27	74.00	-21.73	248	100	Peak
5150.00	41.12	9.10	50.22	74.00	-23.78	203	100	Peak
5980.00	41.39	10.82	52.21	74.00	-21.79	219	200	Peak
6528.00	37.11	11.77	48.88	74.00	-25.12	9	200	Peak
7968.00	36.90	13.02	49.92	74.00	-24.08	306	200	Peak
9576.00	36.48	14.84	51.32	74.00	-22.68	181	200	Peak

**966Chamber\_B at 3Meter / Vertical**

Freq. MHz	Reading dBuV	C.F. dB/m	Result dBuV/m	Limit dBuV/m	Margin dB	Azimuth deg	Height cm	Remark
3930.00	41.68	6.17	47.85	74.00	-26.15	337	200	Peak
5150.00	35.20	9.10	44.30	54.00	-9.70	235	200	Average
5150.00	44.47	9.10	53.57	74.00	-20.43	235	200	Peak
6000.00	41.16	10.87	52.03	74.00	-21.97	185	100	Peak
7020.00	37.36	12.26	49.62	74.00	-24.38	115	100	Peak
8784.00	36.50	13.23	49.73	74.00	-24.27	317	100	Peak
10404.00	29.10	16.53	45.63	54.00	-8.37	214	200	Average
10404.00	37.86	16.53	54.39	74.00	-19.61	214	200	Peak

**Remark:**

1. Measuring frequencies from 1 GHz to the 10th harmonic of highest fundamental frequency.
2. Average test would be performed if the peak result were greater than the average limit.
3. Measurements above show only up to 6 maximum emissions noted, or would be lesser, with " N/A " remark, if no specific emissions from the EUT are recorded (ie: margin>20dB from the applicable limit) and considered that's already beyond the background noise floor.
4. Result = Reading + Correction Factor  
 Margin = Result - Limit  
 Remark Peak = Result(PK) - Limit(PK)  
 Remark AVG = Result(AV) - Limit(AV)

<b>Product Name</b>	All In One Panel PC	<b>Test By</b>	Rex Chiu
<b>Test Model</b>	3365-199	<b>Test Date</b>	2015/09/14
<b>Test Mode</b>	UNII Band 1 / IEEE 802.11an HT20 TX / CH High	<b>Temp. &amp; Humidity</b>	25°C, 50%

**966Chamber\_B at 3Meter / Horizontal**

Freq. MHz	Reading dBuV	C.F. dB/m	Result dBuV/m	Limit dBuV/m	Margin dB	Azimuth deg	Height cm	Remark
3000.00	45.87	4.14	50.01	74.00	-23.99	254	100	Peak
4630.00	40.95	7.95	48.90	74.00	-25.10	132	200	Peak
5430.00	39.28	9.61	48.89	74.00	-25.11	216	200	Peak
7080.00	37.02	12.27	49.29	74.00	-24.71	172	100	Peak
8676.00	36.74	13.22	49.96	74.00	-24.04	269	100	Peak
10488.00	29.30	16.76	46.06	54.00	-7.94	255	100	Average
10488.00	38.03	16.76	54.79	74.00	-19.21	255	100	Peak

**966Chamber\_B at 3Meter / Vertical**

Freq. MHz	Reading dBuV	C.F. dB/m	Result dBuV/m	Limit dBuV/m	Margin dB	Azimuth deg	Height cm	Remark
4985.00	42.08	8.78	50.86	74.00	-23.14	227	100	Peak
5420.00	41.29	9.59	50.88	74.00	-23.12	240	100	Peak
5980.00	41.59	10.82	52.41	74.00	-21.59	187	100	Peak
6732.00	37.04	11.98	49.02	74.00	-24.98	335	100	Peak
8016.00	36.93	13.06	49.99	74.00	-24.01	126	100	Peak
10488.00	29.70	16.76	46.46	54.00	-7.54	243	100	Average
10488.00	38.57	16.76	55.33	74.00	-18.67	243	100	Peak

**Remark:**

1. Measuring frequencies from 1 GHz to the 10th harmonic of highest fundamental frequency.
2. Average test would be performed if the peak result were greater than the average limit.
3. Measurements above show only up to 6 maximum emissions noted, or would be lesser, with " N/A " remark, if no specific emissions from the EUT are recorded (ie: margin>20dB from the applicable limit) and considered that's already beyond the background noise floor.
4. Result = Reading + Correction Factor  
 Margin = Result - Limit  
 Remark Peak = Result(PK) - Limit(PK)  
 Remark AVG = Result(AV) - Limit(AV)

<b>Product Name</b>	All In One Panel PC	<b>Test By</b>	Rex Chiu
<b>Test Model</b>	3365-199	<b>Test Date</b>	2015/09/14
<b>Test Mode</b>	UNII Band 1 / IEEE 802.11an HT40 TX / CH Low	<b>Temp. &amp; Humidity</b>	25°C, 50%

**966Chamber\_B at 3Meter / Horizontal**

Freq. MHz	Reading dBuV	C.F. dB/m	Result dBuV/m	Limit dBuV/m	Margin dB	Azimuth deg	Height cm	Remark
2995.00	46.52	4.13	50.65	74.00	-23.35	231	100	Peak
5470.00	40.10	9.68	49.78	74.00	-24.22	333	100	Peak
5990.00	40.63	10.85	51.48	74.00	-22.52	225	200	Peak
6780.00	37.52	12.03	49.55	74.00	-24.45	109	100	Peak
8208.00	36.69	13.12	49.81	74.00	-24.19	310	200	Peak
10008.00	36.74	15.45	52.19	74.00	-21.81	40	200	Peak

**966Chamber\_B at 3Meter / Vertical**

Freq. MHz	Reading dBuV	C.F. dB/m	Result dBuV/m	Limit dBuV/m	Margin dB	Azimuth deg	Height cm	Remark
4025.00	41.28	6.48	47.76	74.00	-26.24	294	200	Peak
5465.00	41.75	9.68	51.43	74.00	-22.57	193	100	Peak
5975.00	41.07	10.81	51.88	74.00	-22.12	184	100	Peak
6672.00	37.10	11.92	49.02	74.00	-24.98	228	100	Peak
7968.00	37.61	13.02	50.63	74.00	-23.37	196	100	Peak
10020.00	36.18	15.48	51.66	74.00	-22.34	310	100	Peak

**Remark:**

1. Measuring frequencies from 1 GHz to the 10th harmonic of highest fundamental frequency.
2. Average test would be performed if the peak result were greater than the average limit.
3. Measurements above show only up to 6 maximum emissions noted, or would be lesser, with " N/A " remark, if no specific emissions from the EUT are recorded (ie: margin>20dB from the applicable limit) and considered that's already beyond the background noise floor.
4. Result = Reading + Correction Factor  
 Margin = Result – Limit  
 Remark Peak = Result(PK) – Limit(PK)  
 Remark AVG = Result(AV) – Limit(AV)

<b>Product Name</b>	All In One Panel PC	<b>Test By</b>	Rex Chiu
<b>Test Model</b>	3365-199	<b>Test Date</b>	2015/09/14
<b>Test Mode</b>	UNII Band 1 / IEEE 802.11an HT40 TX / CH High	<b>Temp. &amp; Humidity</b>	25°C, 50%

**966Chamber\_B at 3Meter / Horizontal**

Freq. MHz	Reading dBuV	C.F. dB/m	Result dBuV/m	Limit dBuV/m	Margin dB	Azimuth deg	Height cm	Remark
2995.00	46.44	4.13	50.57	74.00	-23.43	249	100	Peak
5150.00	41.66	9.10	50.76	74.00	-23.24	222	100	Peak
5975.00	40.53	10.81	51.34	74.00	-22.66	217	200	Peak
7116.00	37.08	12.28	49.36	74.00	-24.64	110	200	Peak
8892.00	36.27	13.24	49.51	74.00	-24.49	170	100	Peak
10464.00	29.10	16.69	45.79	54.00	-8.21	193	200	Average
10464.00	38.82	16.69	55.51	74.00	-18.49	193	200	Peak

**966Chamber\_B at 3Meter / Vertical**

Freq. MHz	Reading dBuV	C.F. dB/m	Result dBuV/m	Limit dBuV/m	Margin dB	Azimuth deg	Height cm	Remark
3985.00	41.48	6.37	47.85	74.00	-26.15	259	200	Peak
5150.00	40.20	9.10	49.30	54.00	-4.70	244	200	Average
5150.00	58.70	9.10	67.80	74.00	-6.20	244	200	Peak
5590.00	41.29	9.94	51.23	74.00	-22.77	226	200	Peak
7368.00	37.02	12.35	49.37	74.00	-24.63	293	200	Peak
8592.00	36.43	13.21	49.64	74.00	-24.36	88	200	Peak
10464.00	27.80	16.69	44.49	54.00	-9.51	248	100	Average
10464.00	36.55	16.69	53.24	74.00	-20.76	248	100	Peak

**Remark:**

1. Measuring frequencies from 1 GHz to the 10th harmonic of highest fundamental frequency.
2. Average test would be performed if the peak result were greater than the average limit.
3. Measurements above show only up to 6 maximum emissions noted, or would be lesser, with " N/A " remark, if no specific emissions from the EUT are recorded (ie: margin>20dB from the applicable limit) and considered that's already beyond the background noise floor.
4. Result = Reading + Correction Factor  
 Margin = Result – Limit  
 Remark Peak = Result(PK) – Limit(PK)  
 Remark AVG = Result(AV) – Limit(AV)

<b>Product Name</b>	All In One Panel PC	<b>Test By</b>	Rex Chiu
<b>Test Model</b>	3365-199	<b>Test Date</b>	2015/09/14
<b>Test Mode</b>	UNII Band 3 / IEEE 802.11a TX / CH Low	<b>Temp. &amp; Humidity</b>	25°C, 50%

**966Chamber\_B at 3Meter / Horizontal**

Freq. MHz	Reading dBuV	C.F. dB/m	Result dBuV/m	Limit dBuV/m	Margin dB	Azimuth deg	Height cm	Remark
3000.00	46.58	4.14	50.72	74.00	-23.28	259	100	Peak
3830.00	44.07	5.81	49.88	74.00	-24.12	252	100	Peak
5725.00	34.07	10.25	44.32	54.00	-9.68	215	100	Average
5725.00	50.74	10.25	60.99	74.00	-13.01	215	100	Peak
5845.00	38.15	10.52	48.67	74.00	-25.33	324	200	Peak
6648.00	38.07	11.89	49.96	74.00	-24.04	66	200	Peak
8712.00	36.43	13.22	49.65	74.00	-24.35	0	100	Peak
10032.00	36.23	15.52	51.75	74.00	-22.25	97	200	Peak

**966Chamber\_B at 3Meter / Vertical**

Freq. MHz	Reading dBuV	C.F. dB/m	Result dBuV/m	Limit dBuV/m	Margin dB	Azimuth deg	Height cm	Remark
4980.00	41.40	8.77	50.17	74.00	-23.83	197	100	Peak
5725.00	39.13	10.25	49.38	54.00	-4.62	228	200	Average
5725.00	62.23	10.25	72.48	74.00	-1.52	228	200	Peak
5845.00	37.68	10.52	48.20	74.00	-25.80	104	100	Peak
5975.00	41.22	10.81	52.03	74.00	-21.97	236	200	Peak
6924.00	37.15	12.17	49.32	74.00	-24.68	262	200	Peak
8256.00	36.34	13.13	49.47	74.00	-24.53	226	200	Peak
9516.00	35.94	14.76	50.70	74.00	-23.30	196	200	Peak

**Remark:**

1. Measuring frequencies from 1 GHz to the 10th harmonic of highest fundamental frequency.
2. Average test would be performed if the peak result were greater than the average limit.
3. Measurements above show only up to 6 maximum emissions noted, or would be lesser, with " N/A " remark, if no specific emissions from the EUT are recorded (ie: margin>20dB from the applicable limit) and considered that's already beyond the background noise floor.
4.  $Result = Reading + Correction\ Factor$   
 $Margin = Result - Limit$   
 $Remark\ Peak = Result(PK) - Limit(PK)$   
 $Remark\ AVG = Result(AV) - Limit(AV)$

<b>Product Name</b>	All In One Panel PC	<b>Test By</b>	Rex Chiu
<b>Test Model</b>	3365-199	<b>Test Date</b>	2015/09/14
<b>Test Mode</b>	UNII Band 3 / IEEE 802.11a TX / CH Middle	<b>Temp. &amp; Humidity</b>	25°C, 50%

**966Chamber\_B at 3Meter / Horizontal**

Freq. MHz	Reading dBuV	C.F. dB/m	Result dBuV/m	Limit dBuV/m	Margin dB	Azimuth deg	Height cm	Remark
2995.00	47.27	4.13	51.40	74.00	-22.60	261	100	Peak
3855.00	44.17	5.90	50.07	74.00	-23.93	277	100	Peak
5590.00	39.08	9.94	49.02	74.00	-24.98	275	100	Peak
5850.00	36.92	10.53	47.45	74.00	-26.55	301	200	Peak
7080.00	36.86	12.27	49.13	74.00	-24.87	340	200	Peak
11568.00	30.20	18.64	48.84	54.00	-5.16	234	100	Average
11568.00	40.02	18.64	58.66	74.00	-15.34	234	100	Peak
17364.00	26.20	26.30	52.50	54.00	-1.50	218	100	Average
17364.00	39.14	26.30	65.44	74.00	-8.56	218	100	Peak

**966Chamber\_B at 3Meter / Vertical**

Freq. MHz	Reading dBuV	C.F. dB/m	Result dBuV/m	Limit dBuV/m	Margin dB	Azimuth deg	Height cm	Remark
5310.00	42.29	9.39	51.68	74.00	-22.32	234	200	Peak
5725.00	34.80	10.25	45.05	54.00	-8.95	263	100	Average
5725.00	42.14	10.25	52.39	74.00	-21.61	263	100	Peak
5850.00	39.64	10.53	50.17	74.00	-23.83	240	100	Peak
7188.00	37.17	12.30	49.47	74.00	-24.53	146	100	Peak
11568.00	30.55	18.64	49.19	54.00	-4.81	226	200	Average
11568.00	40.76	18.64	59.40	74.00	-14.60	226	200	Peak
17352.00	26.00	26.30	52.30	54.00	-1.70	256	100	Average
17352.00	42.83	26.30	69.13	74.00	-4.87	256	100	Peak

**Remark:**

1. Measuring frequencies from 1 GHz to the 10th harmonic of highest fundamental frequency.
2. Average test would be performed if the peak result were greater than the average limit.
3. Measurements above show only up to 6 maximum emissions noted, or would be lesser, with " N/A " remark, if no specific emissions from the EUT are recorded (ie: margin>20dB from the applicable limit) and considered that's already beyond the background noise floor.
4. Result = Reading + Correction Factor  
 Margin = Result - Limit  
 Remark Peak = Result(PK) - Limit(PK)  
 Remark AVG = Result(AV) - Limit(AV)

<b>Product Name</b>	All In One Panel PC	<b>Test By</b>	Rex Chiu
<b>Test Model</b>	3365-199	<b>Test Date</b>	2015/09/14
<b>Test Mode</b>	UNII Band 3 / IEEE 802.11a TX / CH High	<b>Temp. &amp; Humidity</b>	25°C, 50%

**966Chamber\_B at 3Meter / Horizontal**

Freq. MHz	Reading dBuV	C.F. dB/m	Result dBuV/m	Limit dBuV/m	Margin dB	Azimuth deg	Height cm	Remark
2995.00	46.88	4.13	51.01	74.00	-22.99	248	100	Peak
3885.00	44.84	6.01	50.85	74.00	-23.15	241	100	Peak
5850.00	31.61	10.53	42.14	54.00	-11.86	215	191	Average
5850.00	55.27	10.53	65.80	74.00	-8.20	215	191	Peak
7188.00	37.22	12.30	49.52	74.00	-24.48	244	200	Peak
9888.00	35.99	15.28	51.27	74.00	-22.73	251	200	Peak
11652.00	27.80	18.85	46.65	54.00	-7.35	244	200	Average
11652.00	37.19	18.85	56.04	74.00	-17.96	244	200	Peak

**966Chamber\_B at 3Meter / Vertical**

Freq. MHz	Reading dBuV	C.F. dB/m	Result dBuV/m	Limit dBuV/m	Margin dB	Azimuth deg	Height cm	Remark
4520.00	41.71	7.70	49.41	74.00	-24.59	300	200	Peak
5480.00	41.35	9.70	51.05	74.00	-22.95	241	100	Peak
5850.00	37.21	10.53	47.74	54.00	-6.26	242	100	Average
5850.00	62.49	10.53	73.02	74.00	-0.98	242	100	Peak
6540.00	36.67	11.78	48.45	74.00	-25.55	72	200	Peak
8424.00	36.15	13.18	49.33	74.00	-24.67	169	200	Peak
10500.00	35.49	16.79	52.28	74.00	-21.72	330	200	Peak

**Remark:**

1. Measuring frequencies from 1 GHz to the 10th harmonic of highest fundamental frequency.
2. Average test would be performed if the peak result were greater than the average limit.
3. Measurements above show only up to 6 maximum emissions noted, or would be lesser, with " N/A " remark, if no specific emissions from the EUT are recorded (ie: margin>20dB from the applicable limit) and considered that's already beyond the background noise floor.
4. Result = Reading + Correction Factor  
 Margin = Result - Limit  
 Remark Peak = Result(PK) - Limit(PK)  
 Remark AVG = Result(AV) - Limit(AV)

<b>Product Name</b>	All In One Panel PC	<b>Test By</b>	Rex Chiu
<b>Test Model</b>	3365-199	<b>Test Date</b>	2015/09/14
<b>Test Mode</b>	UNII Band 3 / IEEE 802.11an HT20 TX / CH Low	<b>Temp. &amp; Humidity</b>	25°C, 50%

**966Chamber\_B at 3Meter / Horizontal**

Freq. MHz	Reading dBuV	C.F. dB/m	Result dBuV/m	Limit dBuV/m	Margin dB	Azimuth deg	Height cm	Remark
2995.00	47.41	4.13	51.54	74.00	-22.46	243	100	Peak
3830.00	44.47	5.81	50.28	74.00	-23.72	268	100	Peak
5725.00	38.50	10.25	48.75	54.00	-5.25	250	100	Average
5725.00	48.28	10.25	58.53	74.00	-15.47	250	100	Peak
6984.00	37.28	12.23	49.51	74.00	-24.49	346	200	Peak
8640.00	37.35	13.21	50.56	74.00	-23.44	242	200	Peak
10524.00	35.41	16.83	52.24	74.00	-21.76	49	200	Peak

**966Chamber\_B at 3Meter / Vertical**

Freq. MHz	Reading dBuV	C.F. dB/m	Result dBuV/m	Limit dBuV/m	Margin dB	Azimuth deg	Height cm	Remark
5315.00	41.37	9.40	50.77	74.00	-23.23	219	200	Peak
5725.00	41.67	10.25	51.92	54.00	-2.08	234	126	Average
5725.00	62.69	10.25	72.94	74.00	-1.06	234	126	Peak
6000.00	41.19	10.87	52.06	74.00	-21.94	208	200	Peak
6696.00	36.50	11.94	48.44	74.00	-25.56	181	100	Peak
8064.00	36.19	13.08	49.27	74.00	-24.73	12	100	Peak
9636.00	36.81	14.93	51.74	74.00	-22.26	310	100	Peak

**Remark:**

1. Measuring frequencies from 1 GHz to the 10th harmonic of highest fundamental frequency.
2. Average test would be performed if the peak result were greater than the average limit.
3. Measurements above show only up to 6 maximum emissions noted, or would be lesser, with " N/A " remark, if no specific emissions from the EUT are recorded (ie: margin>20dB from the applicable limit) and considered that's already beyond the background noise floor.
4.  $Result = Reading + Correction\ Factor$   
 $Margin = Result - Limit$   
 $Remark\ Peak = Result(PK) - Limit(PK)$   
 $Remark\ AVG = Result(AV) - Limit(AV)$



<b>Product Name</b>	All In One Panel PC	<b>Test By</b>	Rex Chiu
<b>Test Model</b>	3365-199	<b>Test Date</b>	2015/09/14
<b>Test Mode</b>	UNII Band 3 / IEEE 802.11an HT20 TX / CH Middle	<b>Temp. &amp; Humidity</b>	25°C, 50%

**966Chamber\_B at 3Meter / Horizontal**

Freq. MHz	Reading dBuV	C.F. dB/m	Result dBuV/m	Limit dBuV/m	Margin dB	Azimuth deg	Height cm	Remark
2990.00	46.08	4.12	50.20	74.00	-23.80	249	200	Peak
3855.00	45.91	5.90	51.81	74.00	-22.19	256	100	Peak
5985.00	40.47	10.84	51.31	74.00	-22.69	222	200	Peak
7164.00	37.24	12.29	49.53	74.00	-24.47	360	200	Peak
11568.00	31.04	18.64	49.68	54.00	-4.32	185	200	Average
11568.00	40.73	18.64	59.37	74.00	-14.63	185	200	Peak
17352.00	26.30	26.30	52.60	54.00	-1.40	243	100	Average
17352.00	39.41	26.30	65.71	74.00	-8.29	243	100	Peak

**966Chamber\_B at 3Meter / Vertical**

Freq. MHz	Reading dBuV	C.F. dB/m	Result dBuV/m	Limit dBuV/m	Margin dB	Azimuth deg	Height cm	Remark
5435.00	42.07	9.62	51.69	74.00	-22.31	238	200	Peak
5725.00	36.10	10.25	46.35	54.00	-7.65	259	100	Average
5725.00	46.26	10.25	56.51	74.00	-17.49	259	100	Peak
5980.00	40.77	10.82	51.59	74.00	-22.41	207	100	Peak
7500.00	37.80	12.38	50.18	74.00	-23.82	306	200	Peak
11568.00	29.33	18.64	47.97	54.00	-6.03	206	200	Average
11568.00	38.67	18.64	57.31	74.00	-16.69	206	200	Peak
17364.00	26.50	26.30	52.80	54.00	-1.20	254	100	Average
17364.00	42.19	26.30	68.49	74.00	-5.51	254	100	Peak

**Remark:**

1. Measuring frequencies from 1 GHz to the 10th harmonic of highest fundamental frequency.
2. Average test would be performed if the peak result were greater than the average limit.
3. Measurements above show only up to 6 maximum emissions noted, or would be lesser, with " N/A " remark, if no specific emissions from the EUT are recorded (ie: margin>20dB from the applicable limit) and considered that's already beyond the background noise floor.
4. Result = Reading + Correction Factor  
Margin = Result - Limit  
Remark Peak = Result(PK) - Limit(PK)  
Remark AVG = Result(AV) - Limit(AV)

<b>Product Name</b>	All In One Panel PC	<b>Test By</b>	Rex Chiu
<b>Test Model</b>	3365-199	<b>Test Date</b>	2015/09/14
<b>Test Mode</b>	UNII Band 3 / IEEE 802.11an HT20 TX / CH High	<b>Temp. &amp; Humidity</b>	25°C, 50%

**966Chamber\_B at 3Meter / Horizontal**

Freq. MHz	Reading dBuV	C.F. dB/m	Result dBuV/m	Limit dBuV/m	Margin dB	Azimuth deg	Height cm	Remark
2995.00	47.53	4.13	51.66	74.00	-22.34	236	100	Peak
3885.00	45.07	6.01	51.08	74.00	-22.92	263	100	Peak
5850.00	31.59	10.53	42.12	54.00	-11.88	217	147	Average
5850.00	54.31	10.53	64.84	74.00	-9.16	217	147	Peak
6720.00	36.65	11.96	48.61	74.00	-25.39	86	200	Peak
8496.00	36.70	13.20	49.90	74.00	-24.10	249	200	Peak
10032.00	36.73	15.52	52.25	74.00	-21.75	174	200	Peak

**966Chamber\_B at 3Meter / Vertical**

Freq. MHz	Reading dBuV	C.F. dB/m	Result dBuV/m	Limit dBuV/m	Margin dB	Azimuth deg	Height cm	Remark
3875.00	43.15	5.97	49.12	74.00	-24.88	360	200	Peak
5330.00	41.69	9.43	51.12	74.00	-22.88	233	200	Peak
5850.00	40.45	10.53	50.98	54.00	-3.02	236	154	Average
5850.00	62.05	10.53	72.58	74.00	-1.42	236	154	Peak
7152.00	37.13	12.29	49.42	74.00	-24.58	351	200	Peak
9000.00	36.72	13.25	49.97	74.00	-24.03	252	100	Peak
10152.00	36.00	15.84	51.84	74.00	-22.16	269	200	Peak

**Remark:**

1. Measuring frequencies from 1 GHz to the 10th harmonic of highest fundamental frequency.
2. Average test would be performed if the peak result were greater than the average limit.
3. Measurements above show only up to 6 maximum emissions noted, or would be lesser, with " N/A " remark, if no specific emissions from the EUT are recorded (ie: margin>20dB from the applicable limit) and considered that's already beyond the background noise floor.
4. Result = Reading + Correction Factor  
 Margin = Result - Limit  
 Remark Peak = Result(PK) - Limit(PK)  
 Remark AVG = Result(AV) - Limit(AV)

<b>Product Name</b>	All In One Panel PC	<b>Test By</b>	Rex Chiu
<b>Test Model</b>	3365-199	<b>Test Date</b>	2015/09/14
<b>Test Mode</b>	UNII Band 3 / IEEE 802.11an HT40 TX / CH Low	<b>Temp. &amp; Humidity</b>	25°C, 50%

**966Chamber\_B at 3Meter / Horizontal**

Freq. MHz	Reading dBuV	C.F. dB/m	Result dBuV/m	Limit dBuV/m	Margin dB	Azimuth deg	Height cm	Remark
2995.00	48.14	4.13	52.27	74.00	-21.73	259	100	Peak
5725.00	38.30	10.25	48.55	54.00	-5.45	216	100	Average
5725.00	48.06	10.25	58.31	74.00	-15.69	216	100	Peak
5975.00	40.99	10.81	51.80	74.00	-22.20	202	100	Peak
6732.00	37.02	11.98	49.00	74.00	-25.00	265	200	Peak
7920.00	36.90	12.95	49.85	74.00	-24.15	116	100	Peak
10152.00	36.38	15.84	52.22	74.00	-21.78	287	200	Peak

**966Chamber\_B at 3Meter / Vertical**

Freq. MHz	Reading dBuV	C.F. dB/m	Result dBuV/m	Limit dBuV/m	Margin dB	Azimuth deg	Height cm	Remark
5450.00	42.18	9.65	51.83	74.00	-22.17	237	200	Peak
5725.00	43.00	10.25	53.25	54.00	-0.75	241	134	Average
5725.00	59.94	10.25	70.19	74.00	-3.81	241	134	Peak
5990.00	41.45	10.85	52.30	74.00	-21.70	196	100	Peak
7044.00	37.08	12.26	49.34	74.00	-24.66	40	200	Peak
8280.00	37.57	13.14	50.71	74.00	-23.29	228	200	Peak
9900.00	36.80	15.29	52.09	74.00	-21.91	349	200	Peak

**Remark:**

1. Measuring frequencies from 1 GHz to the 10th harmonic of highest fundamental frequency.
2. Average test would be performed if the peak result were greater than the average limit.
3. Measurements above show only up to 6 maximum emissions noted, or would be lesser, with " N/A " remark, if no specific emissions from the EUT are recorded (ie: margin>20dB from the applicable limit) and considered that's already beyond the background noise floor.
4. Result = Reading + Correction Factor  
 Margin = Result – Limit  
 Remark Peak = Result(PK) – Limit(PK)  
 Remark AVG = Result(AV) – Limit(AV)

<b>Product Name</b>	All In One Panel PC	<b>Test By</b>	Rex Chiu
<b>Test Model</b>	3365-199	<b>Test Date</b>	2015/09/14
<b>Test Mode</b>	UNII Band 3 / IEEE 802.11an HT40 TX / CH High	<b>Temp. &amp; Humidity</b>	25°C, 50%

**966Chamber\_B at 3Meter / Horizontal**

Freq. MHz	Reading dBuV	C.F. dB/m	Result dBuV/m	Limit dBuV/m	Margin dB	Azimuth deg	Height cm	Remark
3000.00	47.01	4.14	51.15	74.00	-22.85	254	100	Peak
5725.00	33.60	10.25	43.85	54.00	-10.15	238	100	Average
5725.00	45.46	10.25	55.71	74.00	-18.29	238	100	Peak
5850.00	32.70	10.53	43.23	54.00	-10.77	254	100	Average
5850.00	44.24	10.53	54.77	74.00	-19.23	254	100	Peak
6504.00	37.33	11.74	49.07	74.00	-24.93	55	100	Peak
7740.00	36.63	12.71	49.34	74.00	-24.66	230	200	Peak
9768.00	36.76	15.11	51.87	74.00	-22.13	329	100	Peak

**966Chamber\_B at 3Meter / Vertical**

Freq. MHz	Reading dBuV	C.F. dB/m	Result dBuV/m	Limit dBuV/m	Margin dB	Azimuth deg	Height cm	Remark
5275.00	42.54	9.33	51.87	74.00	-22.13	240	200	Peak
5725.00	39.50	10.25	49.75	54.00	-4.25	224	100	Average
5725.00	55.70	10.25	65.95	74.00	-8.05	224	100	Peak
5850.00	40.87	10.53	51.40	54.00	-2.60	242	185	Average
5850.00	60.34	10.53	70.87	74.00	-3.13	242	185	Peak
7200.00	37.98	12.30	50.28	74.00	-23.72	115	100	Peak
11592.00	28.30	18.70	47.00	54.00	-7.00	213	100	Average
11592.00	36.29	18.70	54.99	74.00	-19.01	213	100	Peak
17388.00	26.08	26.32	52.40	54.00	-1.60	256	100	Average
17388.00	36.42	26.32	62.74	74.00	-11.26	256	100	Peak

**Remark:**

1. Measuring frequencies from 1 GHz to the 10th harmonic of highest fundamental frequency.
2. Average test would be performed if the peak result were greater than the average limit.
3. Measurements above show only up to 6 maximum emissions noted, or would be lesser, with " N/A " remark, if no specific emissions from the EUT are recorded (ie: margin>20dB from the applicable limit) and considered that's already beyond the background noise floor.
4. Result = Reading + Correction Factor  
 Margin = Result - Limit  
 Remark Peak = Result(PK) - Limit(PK)  
 Remark AVG = Result(AV) - Limit(AV)



**Detector Mode : Peak Polarity : Vertical**

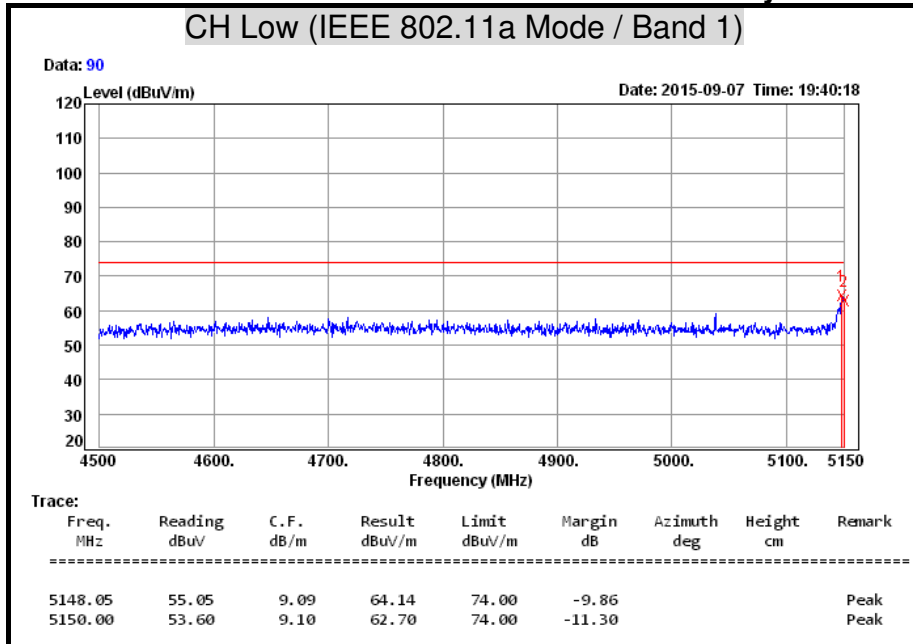

**Detector Mode : Average Polarity : Vertical**

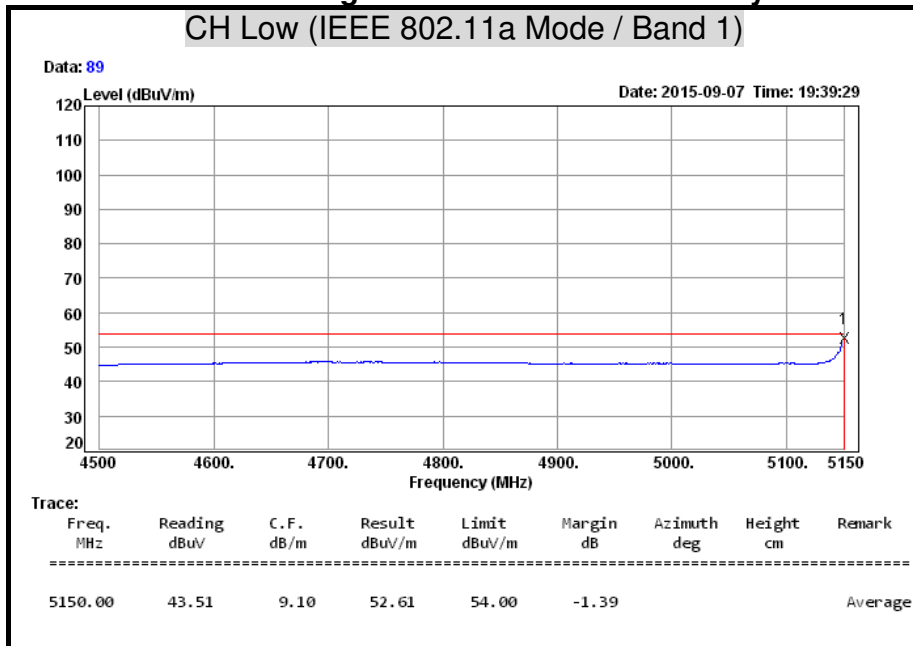









**Detector Mode : Peak Polarity : Vertical**

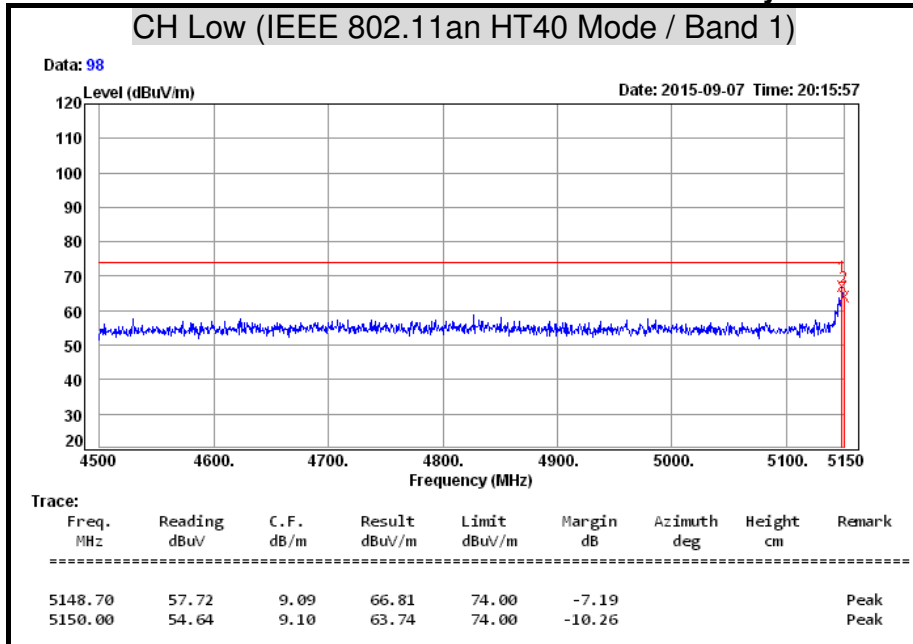

**Detector Mode : Average Polarity : Vertical**

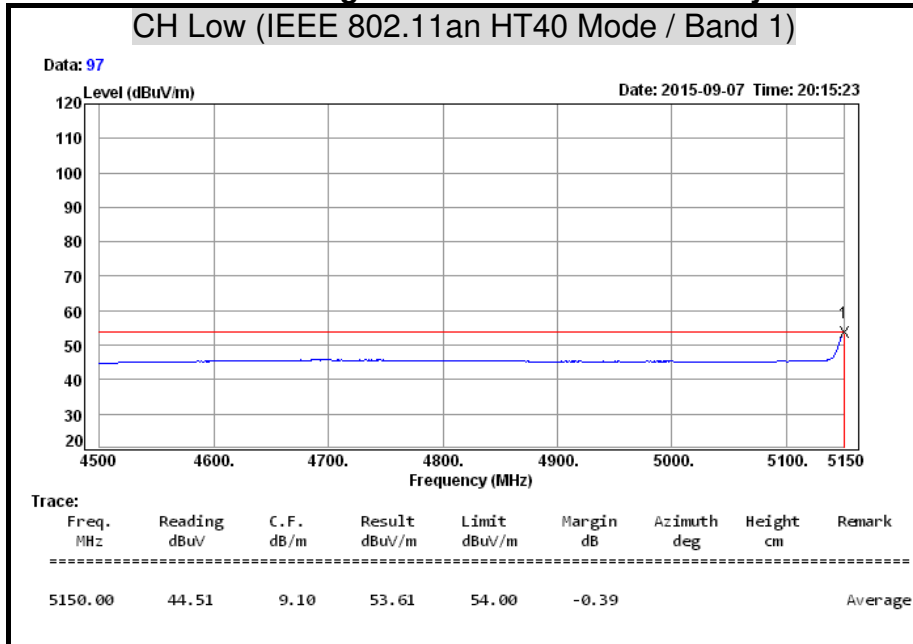

## 7.5 CONDUCTED EMISSION

### LIMITS

§ 15.207 (a) Except as shown in paragraph (b) and (c) this section, for an intentional radiator that is designed to be connected to the public utility (AC) power line, the radio frequency voltage that is conducted back onto the AC power line on any frequency or frequencies within the band 150 kHz to 30 MHz shall not exceed the limits in the following table, as measured using a 50  $\mu$ H/50 ohms line impedance stabilization network (LISN). Compliance with the provisions of this paragraph shall be based on the measurement of the radio frequency voltage between each power line and ground at the power terminal. The lower limit applies at the boundary between the frequency ranges.

Frequency Range (MHz)	Conducted Limit (dB $\mu$ v)	
	Quasi-peak	Average
0.15 - 0.50	66 to 56	56 to 46
0.50 - 5.00	56	46
5.00 - 30.0	60	50

### TEST EQUIPMENT

Name of Equipment	Manufacturer	Model	Serial Number	Calibration Due
L.I.S.N	Schwarzbeck	NSLK 8127	8127465	08/05/2016
L.I.S.N	Schwarzbeck	NSLK 8127	8127473	03/09/2016
EMI Test Receiver	Rohde & Schwarz	ESCS 30	838550/003	11/02/2015
Pulse Limiter	Rohde & Schwarz	ESH3-Z2	100111	06/28/2016

**Remark:** Each piece of equipment is scheduled for calibration once a year.

**TEST SETUP**

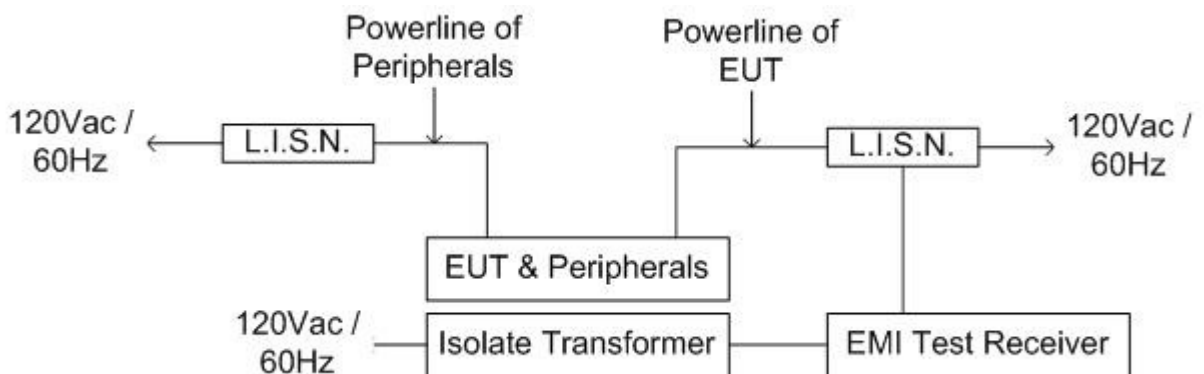
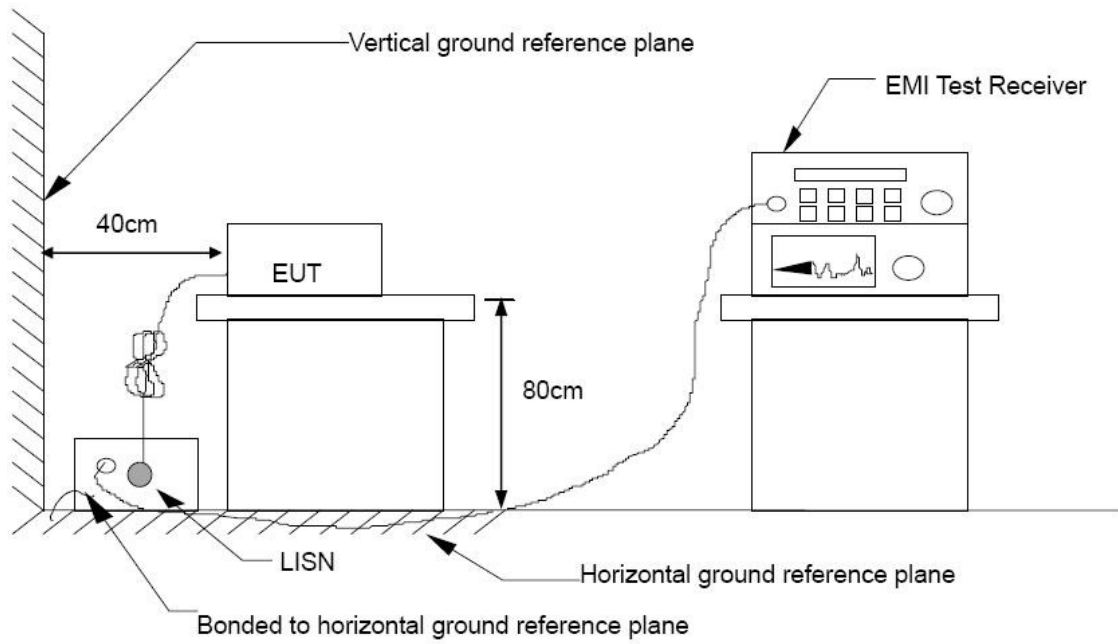

**TEST PROCEDURE**

The basic test procedure was in accordance with ANSI C63.10:2013.

The test procedure is performed in a 4m × 3m × 2.4m (L×W×H) shielded room.

The EUT along with its peripherals were placed on a 1.0m (W) × 1.5m (L) and 0.8m in height wooden table and the EUT was adjusted to maintain a 0.4 meter space from a vertical reference plane.

The EUT was connected to power mains through a line impedance stabilization network (LISN) which provides 50 ohm coupling impedance for measuring instrument and the chassis ground was bounded to the horizontal ground plane of shielded room. All peripherals were connected to the second LISN and the chassis ground also bounded to the horizontal ground plane of shielded room.

The EUT was located so that the distance between the boundary of the EUT and the closest surface of the LISN is 0.8 m. Where a mains flexible cord was provided by the manufacturer shall be 1 m long, or if in excess of 1 m, the excess cable was folded back and forth as far as possible so as to form a bundle not exceeding 0.4 m in length.

**TEST RESULTS**

<b>Product Name</b>	All In One Panel PC	<b>Test By</b>	Alan Wu
<b>Test Model</b>	3365-199	<b>Test Date</b>	2015/10/02
<b>Test Mode</b>	Mode 1	<b>Temp. &amp; Humidity</b>	23°C, 54%

**LINE**

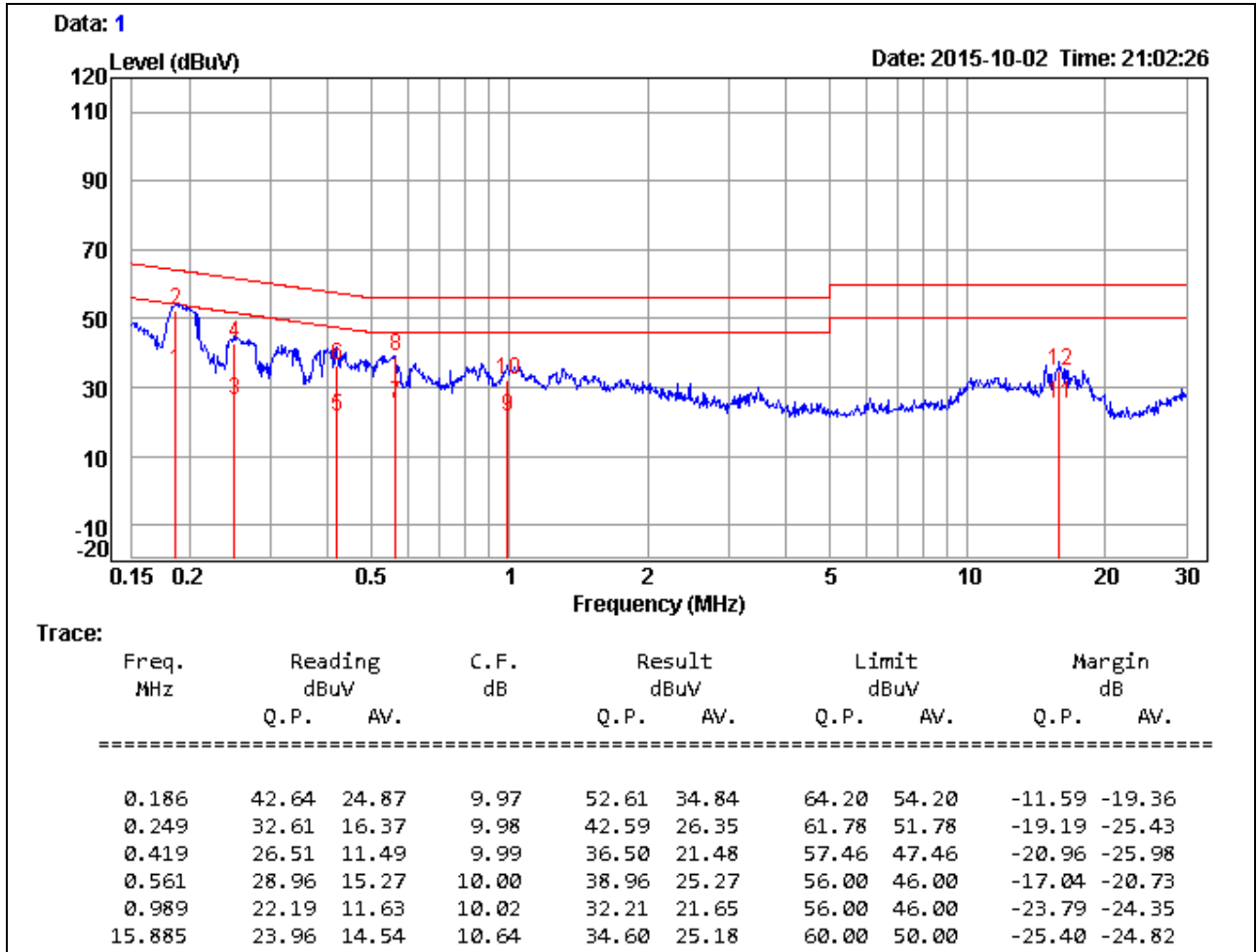

**Remark:**

1. Correction Factor = Insertion loss + Cable loss
2. Result level = Reading Value + Correction factor
3. Margin value = Result level – Limit value

<b>Product Name</b>	All In One Panel PC	<b>Test By</b>	Alan Wu
<b>Test Model</b>	3365-199	<b>Test Date</b>	2015/10/02
<b>Test Mode</b>	Mode 1	<b>Temp. &amp; Humidity</b>	23°C, 54%

NEUTRAL

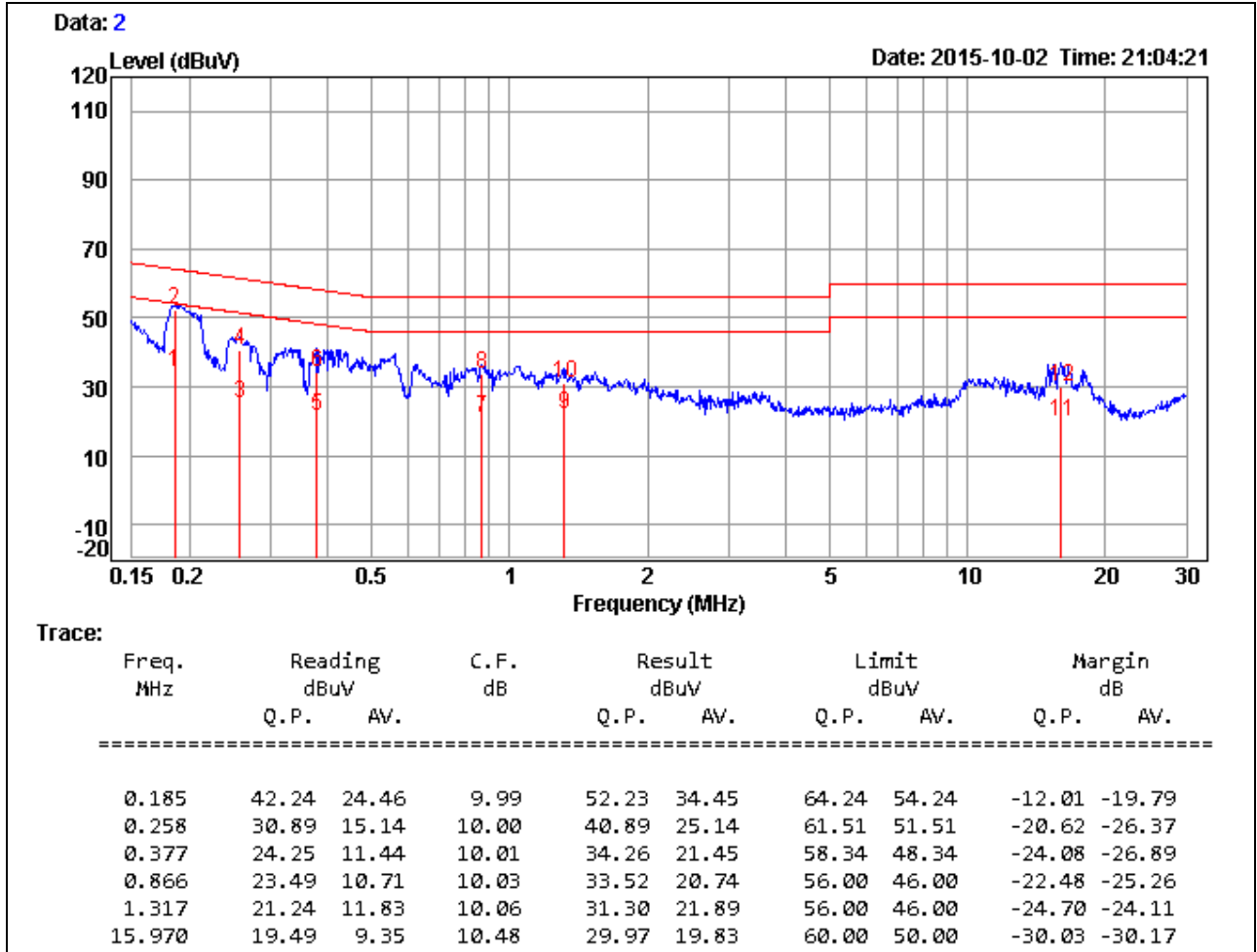

**Remark:**

1. Correction Factor = Insertion loss + Cable loss
2. Result level = Reading Value + Correction factor
3. Margin value = Result level – Limit value

## 7.6 FREQUENCY STABILITY

### LIMITS

§ 15.407 (g) manufacturers of U-NII devices are responsible for ensuring frequency stability such that an emission is maintained within the band of operation under all conditions of normal operation as specified in the user’s manual.

### TEST EQUIPMENT

Name of Equipment	Manufacturer	Model	Serial Number	Calibration Due
EXA Signal Analyzer	Agilent	N9010A	MY52220817	03/19/2016
Temp. & Humid. Chamber	TERCHY	MHC-120L	960424	09/01/2016

*Remark: Each piece of equipment is scheduled for calibration once a year.*

### TEST SETUP

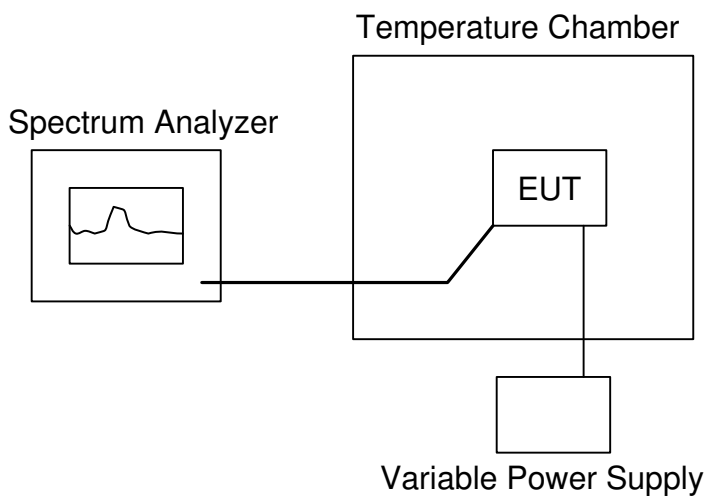



**TEST PROCEDURE**

1. Place the EUT on the table and set it in the transmitting mode.
2. Remove the antenna from the EUT and then connect a low loss RF cable from the antenna port to the spectrum analyzer.
3. Set the environment into appropriate environment.
4. Set the spectrum analyzer as RBW=1kHz, VBW = RBW, Span = 200kHz, Sweep = auto.
5. Mark the peak frequency and measure the frequency tolerance using frequency counter function.
6. Repeat until all the results are investigated.

**TEST RESULTS**

**IEEE 802.11a mode**

U-NII	Channel	Channel Frequency (MHz)	Measured Frequency (MHz)	Delta Frequency (kHz)	20 ppm Limit (kHz)	Margin (kHz)
Band 1	Low	5180	5179.926297	-73.70	103.60	-29.90
	Middle	5200	5199.926410	-73.59	104.00	-30.41
	High	5240	5239.926928	-73.07	104.80	-31.73
Band 3	Low	5745	5744.919337	-80.66	114.90	-34.24
	Middle	5785	5784.918077	-81.92	115.70	-33.78
	High	5825	5824.919174	-80.83	116.50	-35.67

**IEEE 802.11an HT20 Mode**

U-NII	Channel	Channel Frequency (MHz)	Measured Frequency (MHz)	Delta Frequency (kHz)	20 ppm Limit (kHz)	Margin (kHz)
Band 1	Low	5180	5179.926311	-73.69	103.60	-29.91
	Middle	5200	5199.926334	-73.67	104.00	-30.33
	High	5240	5239.926524	-73.48	104.80	-31.32
Band 3	Low	5745	5744.918984	-81.02	114.90	-33.88
	Middle	5785	5784.918685	-81.32	115.70	-34.38
	High	5825	5824.918097	-81.90	116.50	-34.60

**IEEE 802.11an HT40 Mode**

U-NII	Channel	Channel Frequency (MHz)	Measured Frequency (MHz)	Delta Frequency (kHz)	20 ppm Limit (kHz)	Margin (kHz)
Band1	Low	5190	5189.926636	-73.36	103.80	-30.44
	High	5230	5229.926452	-73.55	104.60	-31.05
Band 3	Low	5755	5754.922591	-77.41	115.10	-37.69
	High	5795	5794.920428	-79.57	115.90	-36.33