



TEST REPORT

Test Report No.: 1-4038/11-01-07



Testing Laboratory

CETECOM ICT Services GmbH
 Untertürkheimer Straße 6 – 10
 66117 Saarbrücken/Germany
 Phone: + 49 681 5 98 - 0
 Fax: + 49 681 5 98 - 9075
 Internet: <http://www.cetecom.com>
 e-mail: ict@cetecom.com

Accredited Testing Laboratory:
 The testing laboratory (area of testing) is accredited according to DIN EN ISO/IEC 17025 (2005) by the Deutsche Akkreditierungsstelle GmbH (DAkKS) The accreditation is valid for the scope of testing procedures as stated in the accreditation certificate with the registration number: D-PL-12076-01-01

Applicant

RSI Video Technologies
 56, rue Jean Giraudoux - Bâtiment 60
 67200 Strasbourg/France
 Phone: +33 3 90 20 66 96
 Fax: +33 3 90 20 66 36
 Contact: Thierry Petri
 e-mail: thierry.petri@rsivideotech.com

Manufacturer

Same as Applicant

Test Standard/s

47CFR15	2009-10	Subpart B - Unintentional Radiators
ICES-003, Issue 4	2004-02	Interference-Causing Equipment Standard Digital Apparatus

<p style="text-align: center;">Test Item</p> <p>Kind of test item: Wireless Alarm Model name: XT610 FCC ID: X46XT00 IC: 8816A-XT00 S/N serial number: F4803811230A13EB HW hardware status: 38/11 SW software status: unknown Power Supply: DC 9V</p>	
--	--

This test report is electronically signed and valid without handwritten signature. The public keys can be requested at the test laboratory to verify the electronic signatures.

Test performed:

Test Report authorised:

 Joachim Wolsdorfer
 Testing Manager

 Jens Hennemann
 Testing Manager



1	Table of contents	
1	Table of contents.....	2
2	General information	3
2.1	Notes and disclaimer	3
2.2	Application details	4
3	Test standard/s:.....	4
4	Test Environment	4
5	Test Laboratories sub-contracted	4
6	Information about Test Conditions	5
6.1	Test Item.....	5
6.2	EUT: Type, S/N etc. and Short Descriptions Used in this Test Report.....	5
6.3	Auxiliary Equipment (AE): Type, S/N etc. and Short Descriptions	5
6.4	EUT Set-up(s).....	5
6.5	EUT Operating Modes.....	5
7	Summary of Test Results	6
7.1	Emission.....	6
7.2	Measurement and Test Set-up	7
7.3	Measurement uncertainty.....	7
8	Detailed test results - Emission	8
8.1	Electromagnetic Radiated Emissions (Distance 10 m)	8
8.2	Electromagnetic Radiated Emissions (Distance 5 m)	13
8.3	Conducted Emission.....	18
9	Test equipment and ancillaries used for tests	22
10	Observations	24
	Annex A: Photographs of the test set-up	25
	Annex B: Photographs of the EUT	27
	Annex C: Document history	30
	Annex D: Further information	30

2 General information

2.1 Notes and disclaimer

The test results of this test report relate exclusively to the test item specified in this test report. CETECOM ICT Services GmbH does not assume responsibility for any conclusions and generalizations drawn from the test results with regard to other specimens or samples of the type of the equipment represented by the test item.

The test report may only be reproduced or published in full. Reproduction or publication of extracts from the report requires the prior written approval of CETECOM ICT Services GmbH.

The testing service provided by CETECOM ICT Services GmbH has been rendered under the current "General Terms and Conditions for CETECOM ICT Services GmbH".

CETECOM ICT Services GmbH will not be liable for any loss or damage resulting from false, inaccurate, inappropriate or incomplete product information provided by the customer.

Under no circumstances does the CETECOM ICT Services GmbH test report include any endorsement or warranty regarding the functionality, quality or performance of any other product or service provided.

Under no circumstances does the CETECOM ICT Services GmbH test report include or imply any product or service warranties from CETECOM ICT Services GmbH, including, without limitation, any implied warranties of merchantability, fitness for purpose, or non-infringement, all of which are expressly disclaimed by CETECOM ICT Services GmbH.

All rights and remedies regarding vendor's products and services for which CETECOM ICT Services GmbH has prepared this test report shall be provided by the party offering such products or services and not by CETECOM ICT Services GmbH.

In no case this test report can be considered as a Letter of Approval.

This test report is electronically signed and valid without handwritten signature. For verification of the electronic signatures, the public keys can be requested at the testing laboratory.

2.2 Application details

Date of receipt of order: 2011-12-02
Date of receipt of test item: 2012-03-20
Start of test: 2012-03-23
End of test: 2012-03-23
Person(s) present during the test: -/-

3 Test standard/s:

Test Standard	Version	Test Standard Description
47CFR15	2009-10	Subpart B - Unintentional Radiators
ICES-003, Issue 4	2004-02	Interference-Causing Equipment Standard Digital Apparatus

4 Test Environment

Temperature: 20°C – 25°C
Relative humidity content: 30 % - 50 %
Air pressure: 1020 hPa
Power supply: 230 V / 50 Hz

5 Test Laboratories sub-contracted

6 Information about Test Conditions

6.1 Test Item

Kind of test item :	Wireless Alarm		
Type identification :	XT610		
Equipment classification:	Equipment for fixed use		
Environment classification:	Residential, commercial and light industry		
Supply voltage :	DC 9V and battery		
Ports : (maximum cable lengths declared by manufacturer)	Description	Direction	Length
	DC power port	Input	> 3m
	Signal/control ports	In / output	> 3m
Is mounting position / usual operating position defined?	wall mounted		
Additional information:			
- the radio part of this device is not part of this test report. The device contains a RF module with FCC ID: R17GE862Q2 and IC ID:5131A-GE864Q2.			
-during testing only DC power port has been used			

6.2 EUT: Type, S/N etc. and Short Descriptions Used in this Test Report

short description*)	EUT	Type	S/N serial number	HW hardware status	SW software status
EUT A	wireless Alarm system with GSM	XT610	F4803811230A13EB	38/11	unknown

*) EUT short description is used to simplify the identification of the EUT in this test report.

6.3 Auxiliary Equipment (AE): Type, S/N etc. and Short Descriptions

AE description*)	Auxiliary equipment	Type	S/N serial number	HW hardware status	SW software status
AE A	DC Power Supply	Rohde und Schwarz	1757	unknown	unknown

*) AE short description is used to simplify the identification of the auxiliary equipment in this test report.

6.4 EUT Set-up(s)

EUT set-up no.*)	Combination of EUT and AE	Remarks
set. 1	EUT A + AE A	-/-

*) EUT set-up no. is used to simplify the identification of the EUT set-up in this test report.

6.5 EUT Operating Modes

EUT operating mode no.*)	Description of operating modes	Additional information
op. 1	active	powered by external power supply and batteries plugged in

*) EUT operating mode no. is used to simplify the test report.

7 Summary of Test Results

- No deviations from the technical specifications were ascertained
 There were deviations from the technical specifications ascertained

7.1 Emission

7.1.1 Enclosure

EMI Phenomenon	Frequency range	Basic standard	Result
Radiated Interference Field Strength	30 - 1000 MHz	FCC Part 15 Class B	passed
Radiated Interference Field Strength	> 1 GHz	FCC Part 15 Class B	passed

7.1.2 AC Mains Power Input/Output Ports

EMI Phenomenon	Frequency range	Basic standard	Result
Conducted interference voltage	0,15– 30 MHz	FCC Part 15 Class B	passed

Remarks:

NA1	Not tested because not required by used standard
NA2	Test not applicable because port does not exists
NA3	Test not applicable because port only for services
NA4	Test not applicable because port lengths not longer than 3m
NA5	Not tested because not required by customer
NA6	Not tested because used frequency < 108 MHz

7.2 Measurement and Test Set-up

Note: The test configuration is in accordance with the requirements given in the standards in point 3

7.3 Measurement uncertainty

The uncertainty of the measurement equipment fulfils CISPR 16 and the related European and national standards.

The semi anechoic chamber fulfils the requirements of CISPR 16-1 (ANSI C63.4) for a test volume of 3m Ø.

The uncertainty of the measurement equipment fulfils CISPR 16 and the related European and national standards.

The semi anechoic chamber fulfils the requirements of CISPR 16-1 (ANSI C63.4) for a test volume of 3m Ø.

The table below shows the measurement uncertainties for each measurement method. The expanded uncertainty (k=2 or 95%) was calculated with worst case values.

Measurement Method	Frequency area Impulse duration time	Description	Expanded uncertainty (k=2 or 95%)
Radiated Emission FCC part 15 B, ANSI C63.4	30 MHz – 18 GHz	- / -	± 4.28 dB
Conducted Emission FCC part 15 B, ANSI C63.4	9 kHz – 30 MHz	- / -	± 3.49 dB

8 Detailed test results - Emission

8.1 Electromagnetic Radiated Emissions (Distance 10 m)

8.1.1 Instrumentation for Test (see equipment list)

F 1	F 2	F 4b	F 5	F 6	F 7	F 8	F 21				
-----	-----	------	-----	-----	-----	-----	------	--	--	--	--

8.1.2 Test Plan

EUT set-up	set 1		
Operating mode	Application	Limit	Result
op 1	Enclosure	FCC part 15 B Class B	passed

Remarks: Powered by external power supply (115V / 60Hz)

8.1.3 Radiated Limits

Frequency- range	FCC part 15 B Class B	FCC part 15 B Class A
30 MHz – 88 MHz	30 dB μ V/m	39,1 dB μ V/m
88 MHz – 216 MHz	33,5 dB μ V/m	43,5 dB μ V/m
216 MHz – 960 MHz	36 dB μ V/m	46,4 dB μ V/m
960 MHz – 40000 MHz	44 dB μ V/m	49,5 dB μ V/m
	* This values are recalculated from the class B limits at 3 m antenna distance in §15.109 (g 2) of the FCC rules	

8.1.4 Calibration Information

Device	Serial number	ICT Number	Calibration valid until	Calibration interval
ESCI 3 Receiver	100083/003	300003312	03/2013	12 month
Trilog Antenna	9163-295	300003787	04/2012	24 month
ESU 26	100037	300003555	01/2013	12 month
Horn Antenna	9107-3699	300005222	04/2012	24 month

Remarks:

System check of all relevant devices and the chamber (weekly)

Cable loss: 0.5 to 4.2 dB (30 MHz to 2 GHz); the cable and connectors loss is re-measured every 3 month

8.1.5 Test Results

Common Information

EUT: XT610
 Serial Number: F4803811230A13EB
 Test Description: FCC part 15 B class B
 Operating Conditions: active + GSM idle
 Operator Name: Hennemann
 Comment: DC: 9 V

Scan Setup: STAN_Fin [EMI radiated]

Hardware Setup: Electric Field (NOS)
 Receiver: [ESCI 3]
 Level Unit: dBµV/m
Subrange **Step Size** **Detectors** **IF BW** **Meas. Time** **Preamp**
 30 MHz - 2 GHz 60 kHz QPK 120 kHz 1 s 20 dB

FCC_10m(B)

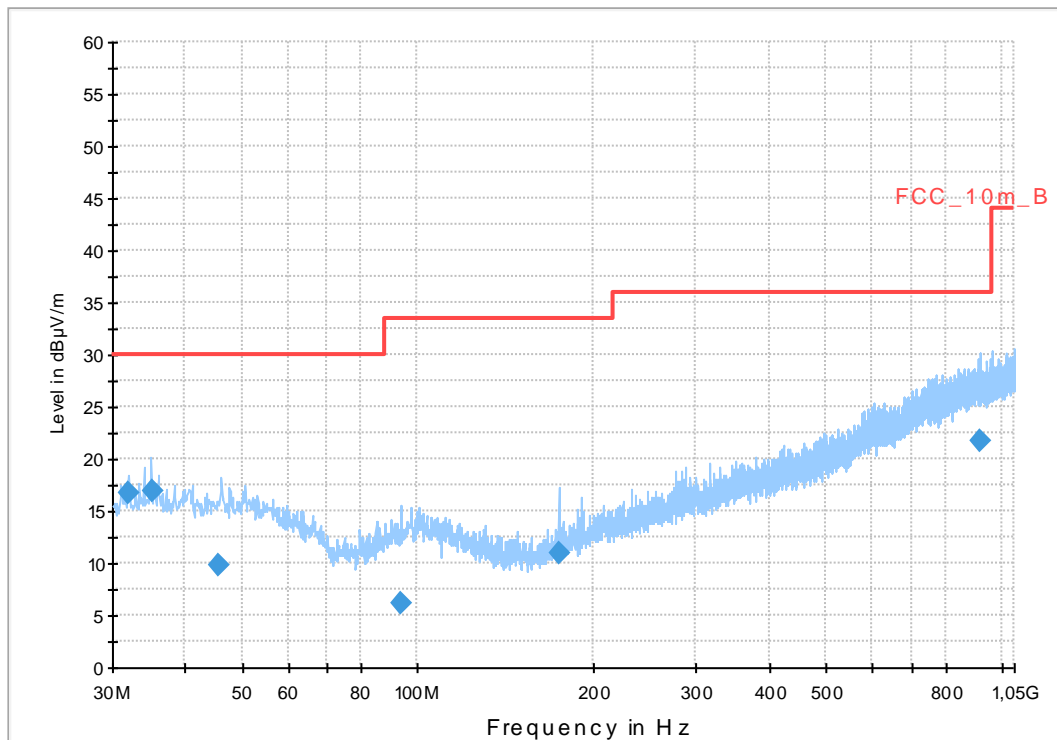

Final Result 1

Frequency (MHz)	QuasiPeak (dBµV/m)	Meas. Time (ms)	Bandwidth (kHz)	Height (cm)	Polarization	Azimuth (deg)	Corr. (dB)	Margi n (dB)	Limit (dBµV/m)	Comment
32.027100	16.8	1000.0	120.000	311.0	V	93.0	12.7	13.2	30.0	
35.012850	16.9	1000.0	120.000	116.0	V	101.0	13.0	13.1	30.0	
45.614400	9.9	1000.0	120.000	145.0	H	270.0	13.3	20.1	30.0	
93.849000	6.2	1000.0	120.000	400.0	H	270.0	11.1	27.3	33.5	
174.445500	10.9	1000.0	120.000	100.0	V	105.0	10.1	22.6	33.5	
916.480650	21.7	1000.0	120.000	400.0	V	142.0	25.3	14.3	36.0	

8.1.6 Hardware Set-up

Subrange 1
Frequency Range: 30 MHz - 2 GHz

Receiver: Receiver [ESCI 3]
@ GPIB0 (ADR 20), SN 100083/003, FW 4.42

Signal Path: without Notch
FW 1.0

Antenna: VULB 9163
SN 9163-295, FW ---
Correction Table (vertical): VULP6113
Correction Table (horizontal): VULP6113
Correction Table (vertical): Cable_EN_1GHz (1005)
Correction Table (horizontal): Cable_EN_1GHz (1005)

Antenna Tower: Tower [EMCO 2090 Antenna Tower]
@ GPIB0 (ADR 8), FW REV 3.12

Turntable: Turntable [EMCO Turntable]
@ GPIB0 (ADR 9), FW REV 3.12

EMC 32 Version 8.52.00

8.1.7 Signal strength calculation

Calculation formula:

$$SS = U_R + CL + AF$$

List of abbreviations:

SS	▶	signal strength
U_R	▶	voltage at the receiver
CL	▶	loss of the cable
AF	▶	antenna factor

List with correction factors:

Frequency [MHz]	CL [dB]	AF [dB μ V/m]
30,000	0,20	12,30
100,000	0,60	11,30
200,000	1,10	10,60
300,000	1,30	13,20
400,000	1,60	15,30
500,000	1,90	16,80
600,000	2,00	18,80
700,000	2,20	20,30
800,000	2,30	21,50
900,000	2,40	22,80
1000,000	2,50	23,30

Example calculation:

For example at 500,000 000 MHz the measured Voltage (U_R) is 12,35 dB μ V/m, the loss of the cable (CL) is 1,90 dB and the antenna factor (AF) is 16,80 dB μ V/m the final result will be calculated:

$$SS \text{ [dB}\mu\text{V]} = 12,35 \text{ [dB}\mu\text{V/m]} + 1,90 \text{ [dB]} + 16,80 \text{ [dB}\mu\text{V/m]} = \underline{31,05 \text{ [dB}\mu\text{V/m]}} \text{ (35,69 } \mu\text{V/m)}$$

8.1.8 Test Set-up

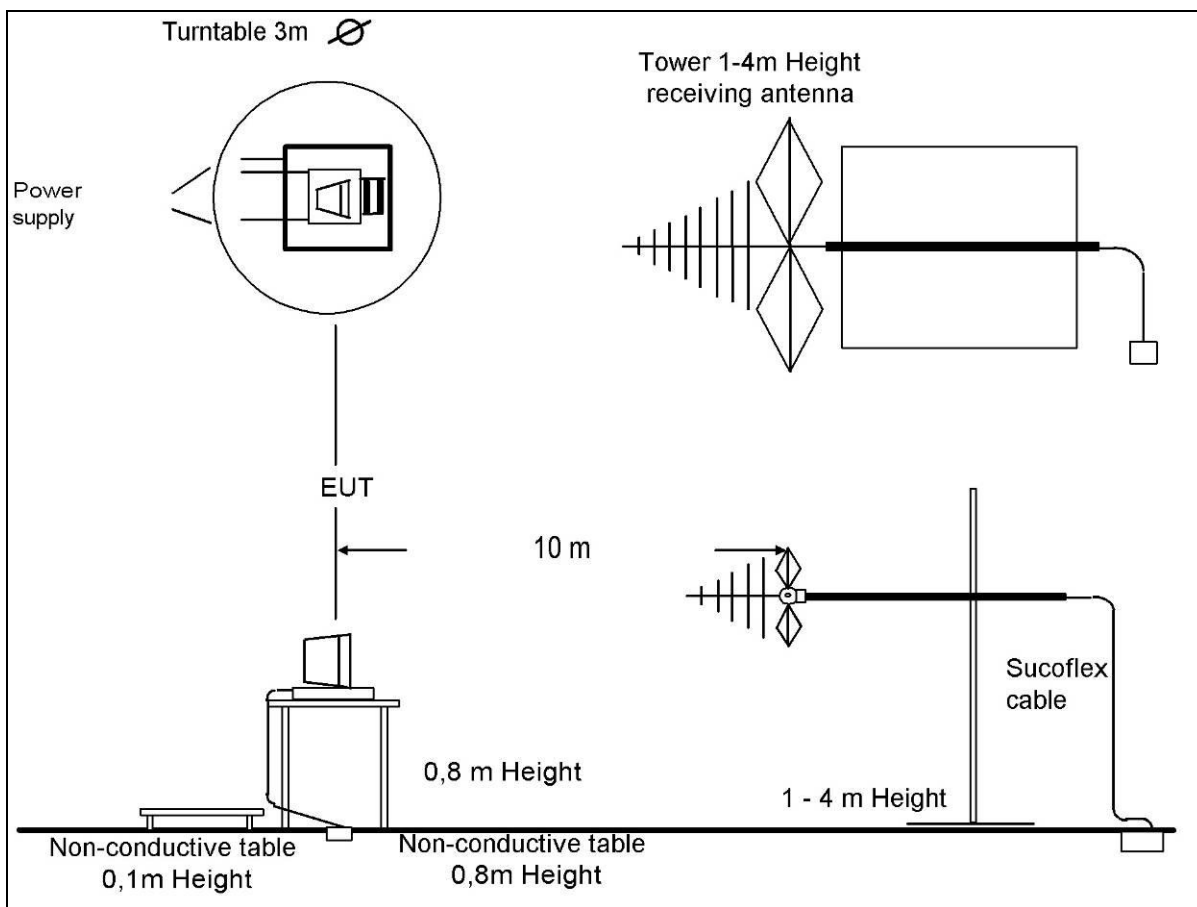

8.2 Electromagnetic Radiated Emissions (Distance 5 m)

8.2.1 Instrumentation for Test (see equipment list)

F 1	F 6	F 29	F 30	F 33	F21						
-----	-----	------	------	------	-----	--	--	--	--	--	--

8.2.2 Test Plan

EUT set-up	set 1		
Operating mode	Application	Limit	Result
op 1	Enclosure	FCC part 15B Class B	passed

Remarks:	The measured values are recalculated from 5m to 3m distance Powered by external power supply (115V / 60Hz)
-----------------	---

8.2.3 Radiated Limits

Frequency- range	CISPR 22 / EN 55022 Class B	CISPR 22 / EN 55022 Class A
30 MHz - 230 MHz	40 dB μ V/m	50 dB μ V/m
230 MHz - 1000 MHz	47 dB μ V/m	57 dB μ V/m
Frequency- range	47CFR15: (FCC part 15 B) Class B	47CFR15: (FCC part 15 B) Class A
1000 MHz – 2000 MHz	54 dB μ V/m	59,5 dB μ V/m

Frequency- range	47CFR15: (FCC part 15 B) Class B	47CFR15: (FCC part 15 B) Class A *
30 MHz – 88 MHz	40 dB μ V/m	49,1 dB μ V/m
88 MHz – 216 MHz	43,5 dB μ V/m	53,5 dB μ V/m
216 MHz – 960 MHz	46 dB μ V/m	56,4 dB μ V/m
960 MHz – 18000 MHz	54 dB μ V/m	59,5 dB μ V/m
		* This values are recalculated from the class A limits at 10 m antenna distance in §15.109 (g 2) of the FCC rules.

8.2.4 Calibration Information

Device	Serial number	ICT Number	Calibration valid until	Calibration interval
ESU 26	100037	300003555	01/2013	12 month
Horn Antenna	9120B188	300003896	04/2012	24 month

Remarks:

System check of all relevant devices and the chamber (weekly)

Cable loss: 0.5 to 4.2 dB (30 MHz to 2 GHz); the cable and connectors loss is re-measured every 3 month

8.2.5 Test Results

Common Information

EUT:	XT610
Serial Number:	F4803811230A13EB
Test Description:	FCC part 15 B class B
Operating Conditions:	active + GSM idle
Operator Name:	Hennemann
Comment:	DC: 9 V

FCC_1_10_B_5m

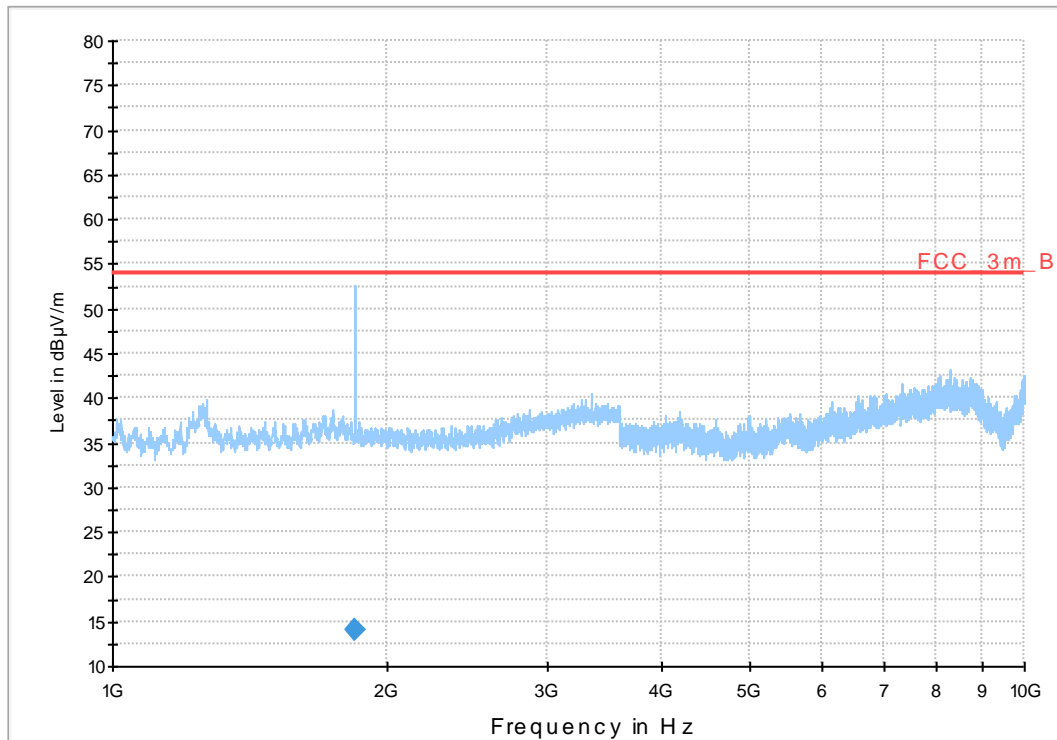

Final Result 1

Frequency (MHz)	Average (dBµV/m)	Meas. Time (ms)	Bandwidth (kHz)	Height (cm)	Polarization	Azimuth (deg)	Corr. (dB)	Margin (dB)	Limit (dBµV/m)	Comment
1846.617254	14.1	100.0	100.000	100.0	V	205.0	-4.1	39.9	54.0	

8.2.6 Hardware Set-up

Subrange 1	
Frequency Range:	1 GHz - 10 GHz
Receiver:	ESU [ESU 26] @ GPIB0 (ADR 17), SN 100037/026, FW 4.43
Signal Path:	1_6_EN FW 1.0 Correction Table: 3_5m Correction Table: LNA_EN (matix)
Antenna:	BBHA 9120 B Correction Table (vertical): BBHA9120 Correction Table (horizontal): BBHA9120 Correction Table (vertical): Cable_Horn_EN (1103) Correction Table (horizontal): Cable_Horn_EN (1103)
Antenna Tower:	Generic Tripod [Generic Tripod] @ GPIB0 (ADR 19), SN ?
Turntable:	Turntable [EMCO Turntable] @ GPIB0 (ADR 9), FW REV 3.12

8.2.7 Signal strength calculation

Calculation formula:

$$SS = U_R + CL + AF + PA + DC$$

List of abbreviations:

SS	▶	signal strength
U_R	▶	voltage at the receiver
CL	▶	loss of the cable and gain of the preamp
AF	▶	antenna factor
DC	▶	distance correction (results measured on 5 m calculated to 3 m)

List with correction factors:

Frequency [GHz]	CL [dB]	AF [dB μ V/m]	DC [dB]
1,000	-35,50	26,20	4,40
1,500	-35,20	26,10	4,40
2,000	-35,10	26,70	4,40
2,500	-35,00	26,50	4,40
3,000	-34,70	27,60	4,40
3,500	-34,80	28,40	4,40
4,000	-35,00	28,60	4,40
4,500	-34,90	28,90	4,40
5,000	-34,80	29,30	4,40
5,500	-34,35	29,80	4,40
6,000	-34,00	30,30	4,40
6,500	-33,50	31,20	4,40
7,000	-33,10	31,20	4,40
7,500	-33,40	31,70	4,40
8,000	-33,80	32,10	4,40
8,500	-33,75	32,30	4,40
9,000	-33,70	31,70	4,40
9,500	-33,50	29,40	4,40
10,000	-33,40	33,00	4,40

Example calculation:

For example at 4,000 000 000 GHz the measured Voltage (U_R) is 46,13 dB μ V/m, the loss of the cable (CL) is -35,00 dB, the antenna factor (AF) is 28,60 dB μ V/m and the distance correction (DC) is 4,40 dB the final result will be calculated:

$$SS \text{ [dB}\mu\text{V]} = 46,13 \text{ [dB}\mu\text{V/m]} + (-35,00) \text{ [dB]} + 28,60 \text{ [dB}\mu\text{V/m]} + 4,4 \text{ [dB]} = \underline{44,13 \text{ [dB}\mu\text{V/m]}} \text{ (160,88 } \mu\text{V/m)}$$

8.2.8 Test Set-up

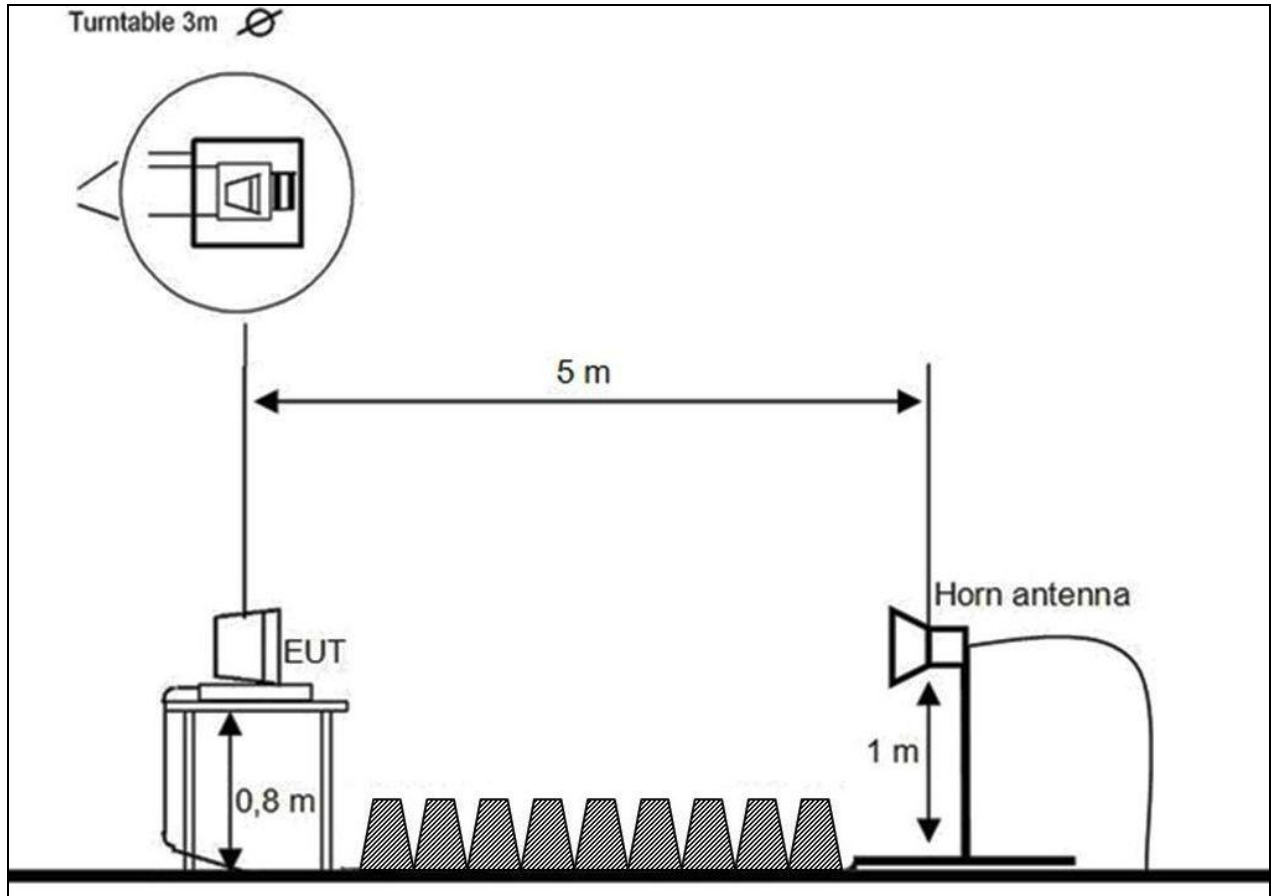

8.3 Conducted Emission

8.3.1 Instrumentation for Test (see equipment list)

G 1	G 2	F 21								
-----	-----	------	--	--	--	--	--	--	--	--

8.3.2 Test Plan

EUT set-up	set 1		
Operating mode	Port / Line	Limit	Result
op 1	AC power line	47CFR15: (FCC part 15 B) Class B	passed

Remark : Powered by external power supply (115V / 60Hz)

8.3.3 Conducted Limits (Power-Line)

Frequency- range	FCC part 15 B Class B		FCC part 15 B Class A	
	Quasi-Peak (dB μ V)	Average (dB μ V)	Quasi-Peak (dB μ V)	Average (dB μ V)
0,15 MHz – 0,5 MHz	66-56	56-46	79	66
0,5 MHz -5 MHz	56	46	73	60
5 MHz -30 MHz	60	50	73	60

8.3.4 Calibration Information

Device	Serial number	ICT Number	Calibration valid until	Calibration interval
HP 8542 EMI Receiver with RF Filter Unit	3617A00170	300000568	01 / 2013	12 month
ESCI	100083	3000003312	03 / 2013	12 month
VISN ESH 3-Z5	892475/017	300002209	01 / 2014	24 month
VISN ESH 2-Z5	892602/024	300000587	01 / 2012	24 month

Remarks: All emission components and the shielded room were checked weekly
Cable loss: 0.6 to 2.4 dB (150kHz to 30 MHz)

8.3.5 Test Results of Main

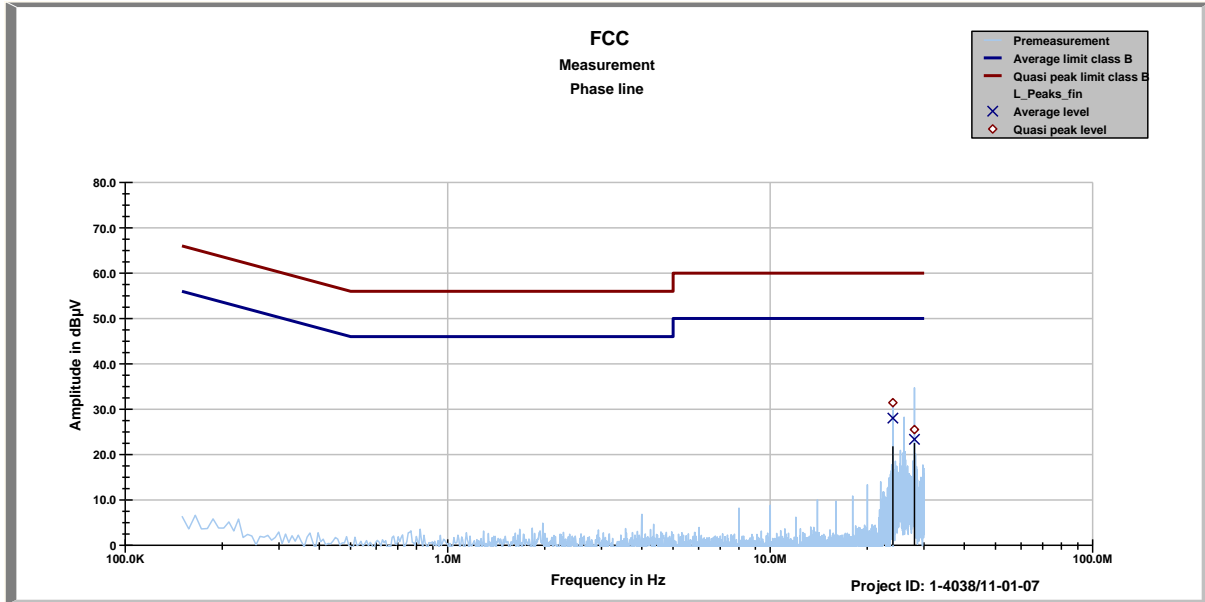

FCC
Phase line tbl

Project ID: 1-4038/11-01-07

11:07:49 AM, Friday, March 23, 2012

Frequency	Quasi peak level	Margin quasi peak	Average level	Margin average
MHz	dBµV	dBµV	dBµV	dBµV
24.003	31.43	28.57	28.03	21.97
28.006	25.50	34.50	23.35	26.65

Project ID - 1-4038/11-01-07
 EUT - XT610
 SN: F4803811230A13EB
 Operating mode - active + GSM idle

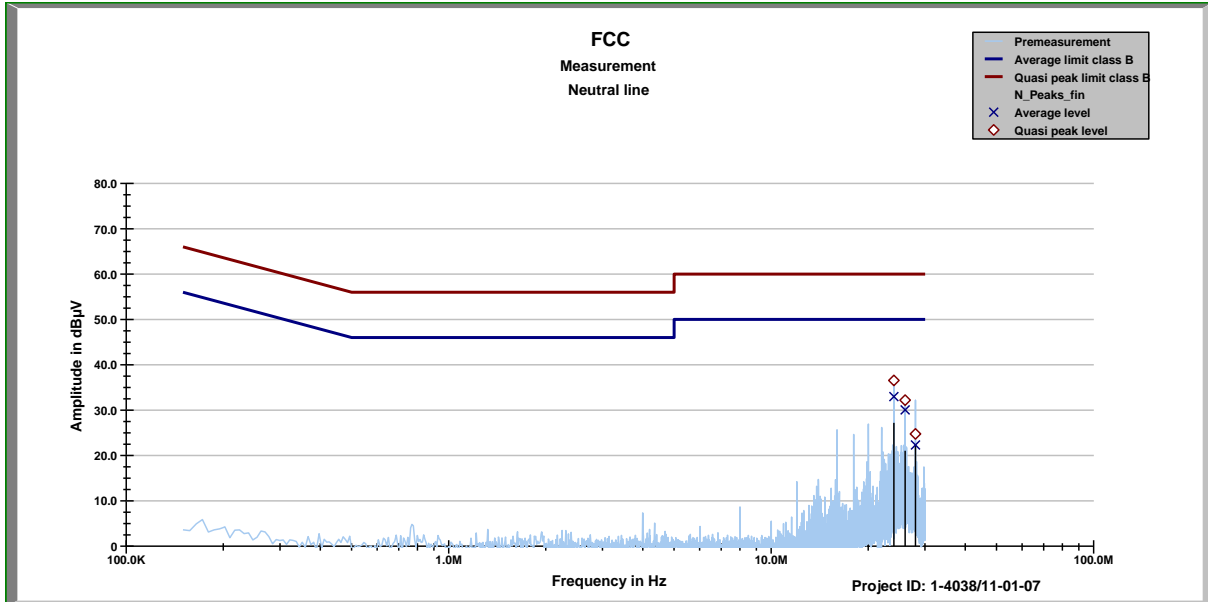

FCC
Neutral line tbl

Project ID: 1-4038/11-01-07

11:07:49 AM, Friday, March 23, 2012

Frequency	Quasi peak level	Margin quasi peak	Average level	Margin average
MHz	dBµV	dBµV	dBµV	dBµV
24.003	36.54	23.46	32.97	17.03
26.002	32.19	27.81	30.04	19.96
28.006	24.75	35.25	22.31	27.69

Project ID - 1-4038/11-01-07
 EUT - XT610
 SN: F4803811230A13EB
 Operating mode - active + GSM idle

8.3.6 Signal strength calculation

Calculation formula:
 $SS = UR + CF + VC$

List of abbreviations:

- SS ► signal strength
- UR ► voltage at the receiver
- CF ► loss of the cable and filter (passband filter 130 kHz – 30 MHz)
- VC ► correction factor of the ISN (ESH3-Z5)

List with correction factors:

Frequency [MHz]	CF [dB]	VC [dB]
0,150	9,80	1,42
1,000	9,80	0,41
5,000	9,90	0,32
10,000	9,90	0,23
15,000	10,00	0,39
20,000	10,00	1,19
25,000	10,20	1,55
30,000	10,30	1,31

Example calculation:

For example at 10,000 000 MHz the measured Voltage (UR) is 37,62 dB μ V, the loss of the cable and filter (CF) is 9,90 dB and the correction factor of the ISN (VC) is 0,23 dB the final result will be calculated:
 $SS \text{ [dB}\mu\text{V]} = 37,62 \text{ [dB}\mu\text{V]} + 9,90 \text{ [dB]} + 0,23 \text{ [dB]} = \underline{47,75 \text{ [dB}\mu\text{V]}} \text{ (244, 06 } \mu\text{V)}$

8.3.7 Test Set-up

According to EMC basic standard **ANSI 63.4**

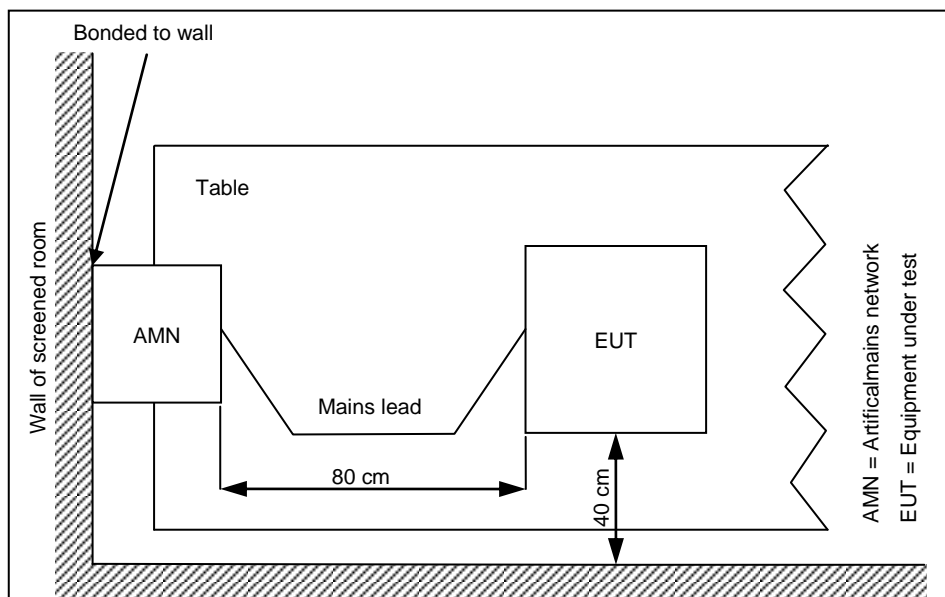

9 Test equipment and ancillaries used for tests

To simplify the identification of the test equipment and/or ancillaries which were used, the reporting of the relevant test cases only refer to the test item number as specified in the table below.

No.	Instrument/Ancillary	Manufacturer	Type	Serial-No.	Internal identification
Radiated emission in chamber F					
F-1	Control Computer	F+W		FW0502032	300003303
F-2	Trilog-Antenna	Schwarzbeck	VULB 9163	9163-295	---
F-3a	Amplifier	Veritech Microwave Inc.	0518C-138	- / -	- / -
F-4b	Switch	HP	3488A	- / -	300000368
F-5	EMI Test receiver	R&S	ESCI	100083	300003312
F-6	Turntable Interface-Box	EMCO / ETS-LINDGREN	Model 105637	44583	300003747
F-7	Tower/Turntable Controller	EMCO / ETS-LINDGREN	Model 2090	64672	300003746
F-8	Tower	EMCO / ETS-LINDGREN	Model 2175	64762	300003745
F-9	Ultra Notch-Filter Rejected band Ch. 62	WRCD		9	
Radiated immunity in chamber F					
F-10	Control Computer	F+W		FW0502032	300003303
F-11	Signal Generator	HP	8665A	2833A00112	300001373
F-12	RF-Amplifier	ar	100W1000 M1	12951	300000529
F-13	Directional Coupler	ar	DC 3010	12708	300001428
F-14	Stacked Logper Antenna	Schwarzbeck	STLP9128 E	9128 E 013	300003408
F-15	RF-Amplifier	ar	60S1G3	313649	300003410
F-15b	RF-Amplifier 0.8 – 4 GHz	BONN	BLMA 0840-2000/100D	076820B	300003783
F-16	Directional Coupler	ar	DC7144A	312786	300003411
F-17	Horn Antenna	ar	AT 4002	19739	300000633
F-18	Power Meter	R&S	NRV	860327/024	F033
F-19	Power sensor	R&S	URV5-Z2	839080/005	300002844.02
F-20	Power sensor	R&S	URV5-Z2	830755/057	F032
Harmonics and flicker in front of chamber F					
F-21	Flicker and Harmonics Test System	Spitzenberger & Spies	PHE4500/B I PHE4500/B II	B5983 B5984	300000210
F-28	Power Supply	Hewlett Packard	6032 A	2920 A 04466	300000580
Radiated emission in chamber F > 1GHz					
F-29	Horn antenna	Schwarzbeck	BBHA 9120 B	9120B188	300003896
F-30	Amplifier	ProNova	0518C-138	005	F 024
F-31	Amplifier	Miteq	42-00502650-28-5A	1103782	300003379
F-32	Horn antenna	Emco	3115	9709-5289	300000213
F-33	Spectrum Analyzer	R&S	ESU26	100037	300003555
F-34	Loop antenna	EMCO	6502	8905-2342	300000256

No.	Instrument/Ancillary	Manufacturer	Type	Serial-No.	Internal identification
Conducted emission in chamber G					
G-1	EMI Receiver	Hewlett Packard	8542 E	3617A00170	300000568
G-2	V-ISN	Rohde & Schwarz	ESH 3-Z5	892475/017	300002209
G-2a	V-ISN	Rohde & Schwarz	ESH 2-Z5	892602/024	300000587
G-3	2-Wire ISN	Schaffner	ISN T200	19075	300003422
G-4	4-Wire ISN	Schaffner	ISN T400	22325	300003423
G-5	Shielded wire ISN	Schaffner	ISN ST08	22583	300003433
G-6	Unshielded 8 wire ISN	Teseq	ISN T800	26113	300003833
G-7	Unshielded 8 wire ISN	Teseq	ISN T8-Cat. 6	26374	300003851
G-8	RF Current probe	FCC	F-33-4	46	300003257
G-9	V-ISN	Schaffner	ISN PLC-150	21579	300003318
G-10	V-ISN	Schaffner	ISN PLC-25-30	21584	300003319
G 10a	PLC Filter	TESEQ	Filter PLC	23436	300003598
G 10b	Coupling unit 75 Ohm	Fiedler	AC	----	300003272.04
Conducted immunity in chamber G					
G-11	Signal generator	R&S	SMG	8610647025	300000204.01
G-12	RF-Amplifier	BONN	BSA 0125-75	066502-01	300003545
G-13	Power Meter	R&S	URV 5	837723/025	300002844.01
G-14	Power Sensor	R&S	URV 5-Z2	832874/021	300002239
G-15	Directional coupler	emv	DC 2000	9401-1677	300000592
G-16	Attenuator 6dB	Alan	50HP6-100 N	121048 0348	300003148
G-17	EM-Injection Clamp	FCC	203i	232	300000626
G-18	CDN	FCC	FCC-801-M3-16	237	300000627
G-19	CDN	FCC	FCC-801-T2	78	300000629
G-20	CDN	FCC	FCC-801-AF 2	62	300000630
G-21	CDN	FCC	FCC-801-AF 4	61	300000631
G-22	CDN	FCC	FCC-801-M1	2027	300002761
G-23	CDN	Lüthi	CDN 801-M2/M3	9350105	300000534
G-24	Transformator for 50Hz Loop Antenna	EM-Test	MC2630	0200-10	300002659.01
G-25	50Hz Loop Antenna	EM-Test	MS 100	none	300002659
Surge, Burst, Dips and Interruptions in chamber G					
G-26	Hybrid-Generator	EM-Test	UCS 500N5	V112711033	300004257
G-27	Motor Variac	EM-Test	MV 2616	0600-01	300002658
G-28	Capacitive Coupling Clamp	MWB	KKS 100	---	300000589
G- 29a	Coupling Decoupling Network	EMC-Partner	CDN-2000-06-32	158	300004108
G-29	Coupling Decoupling Network	EMC-Partner	CDN-UTP	00014	300003226
ESD in chamber G					
G-30	ESD generator	Schaffner	NSG 435	308	300002249
Emission on bench in chamber G					
G-31	Absorbing Clamp	R&S	MDS-21	832 231/006	300000527
generic in chamber G					
G-32	power supply	Hewlett Packard	6038A	2848A06673	300001512

10 Observations

No observations, exceeding those reported with the single test cases, have been made.

Annex A: Photographs of the test set-up

Photo 1: radiated emission < 1GHz

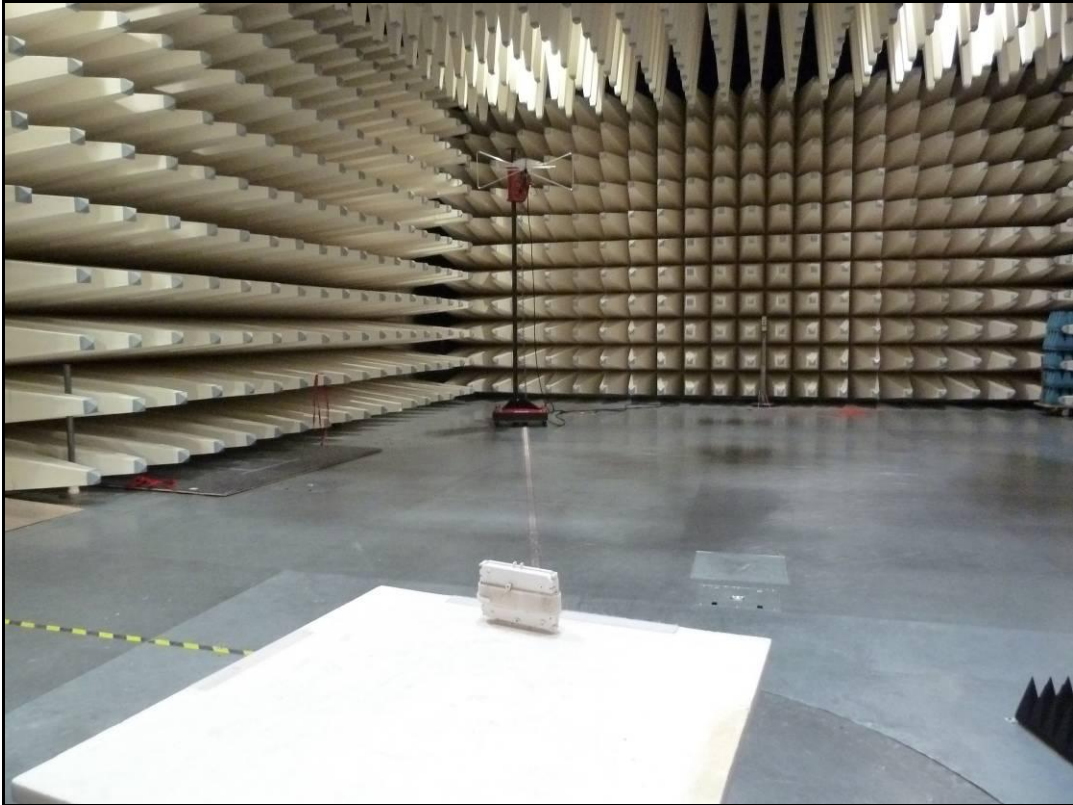
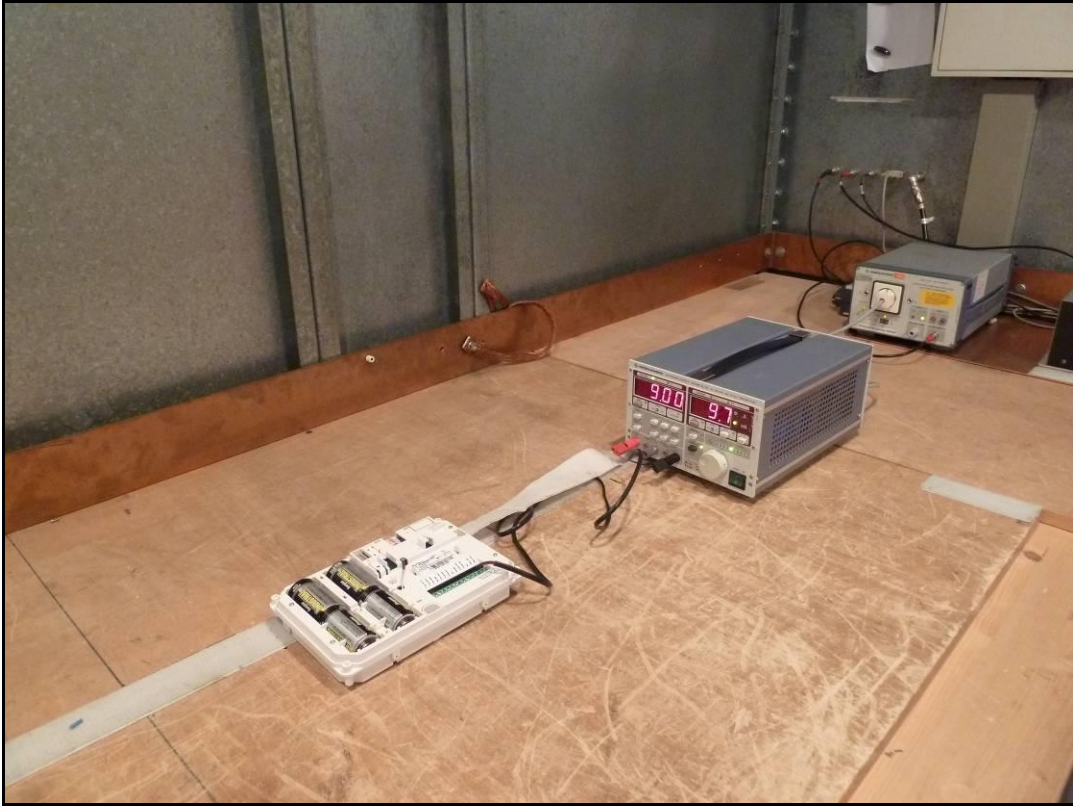

Photo 2: radiated emission 1-10 GHz



Photo 3: conducted emission



Annex B: Photographs of the EUT

Photo 4: EUT A front view



Photo 5: EUT A rear view



Photo 6: EUT A enclosure opened



Photo 7: EUT A enclosure opened with pcb antenna

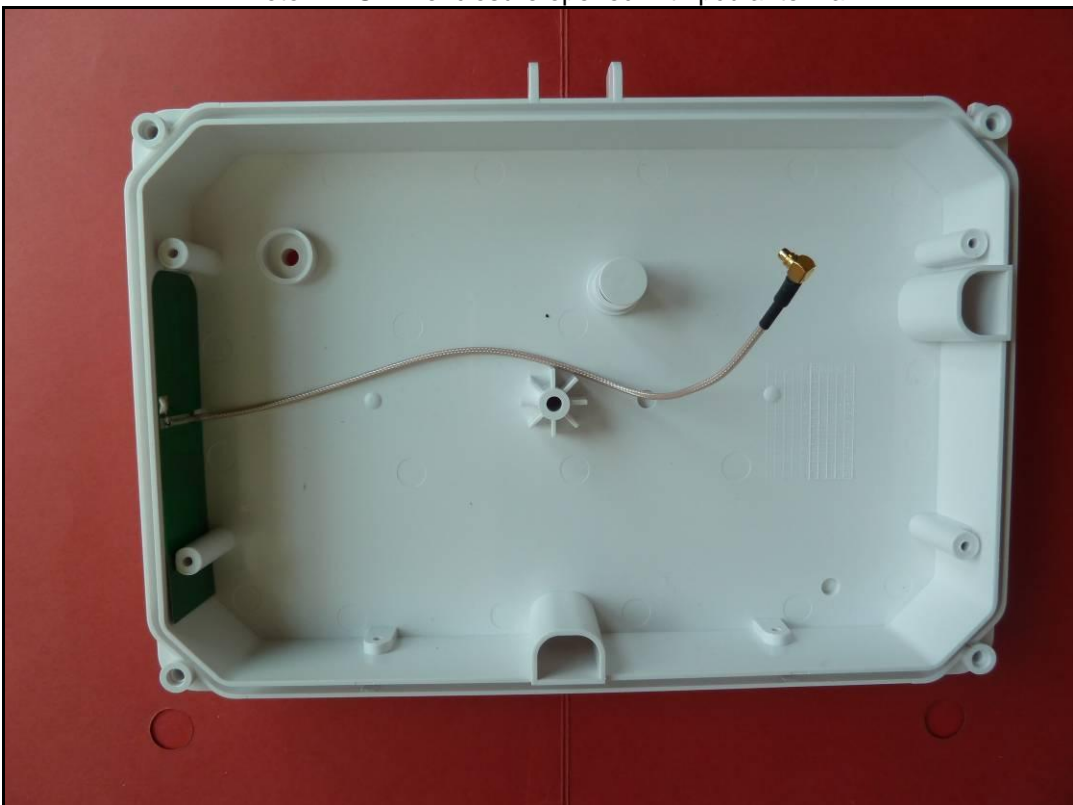

Photo 8: EUT A enclosure opened pcb top view

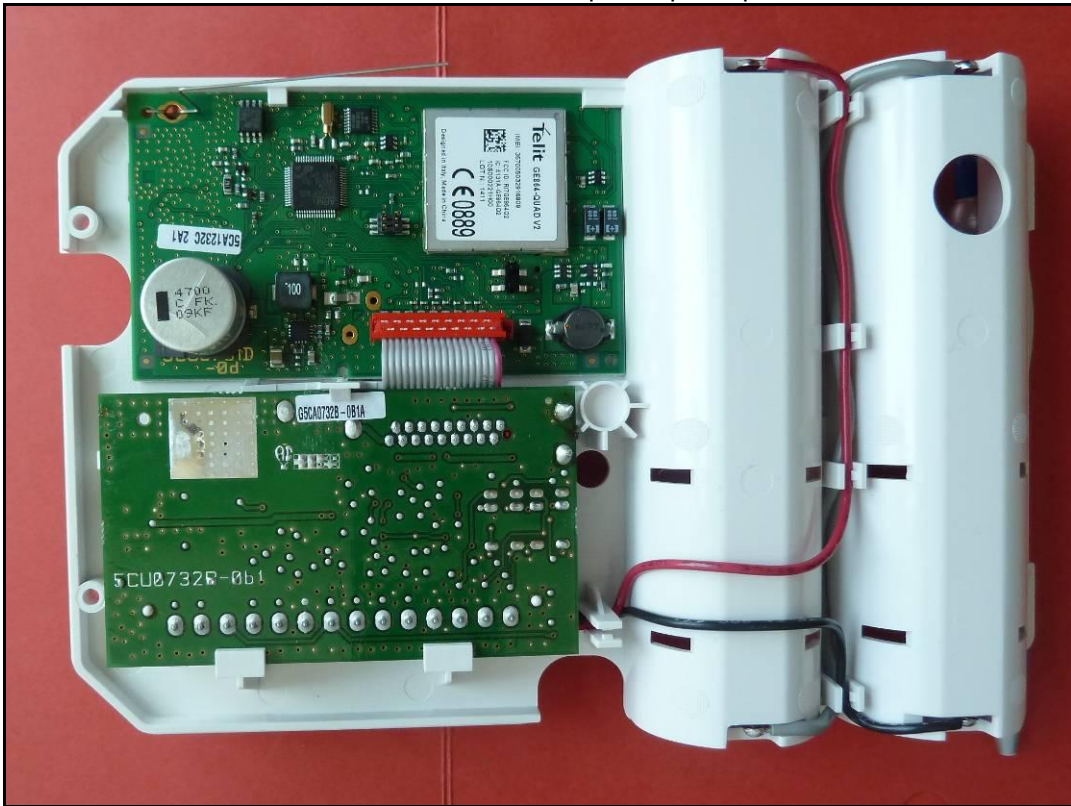
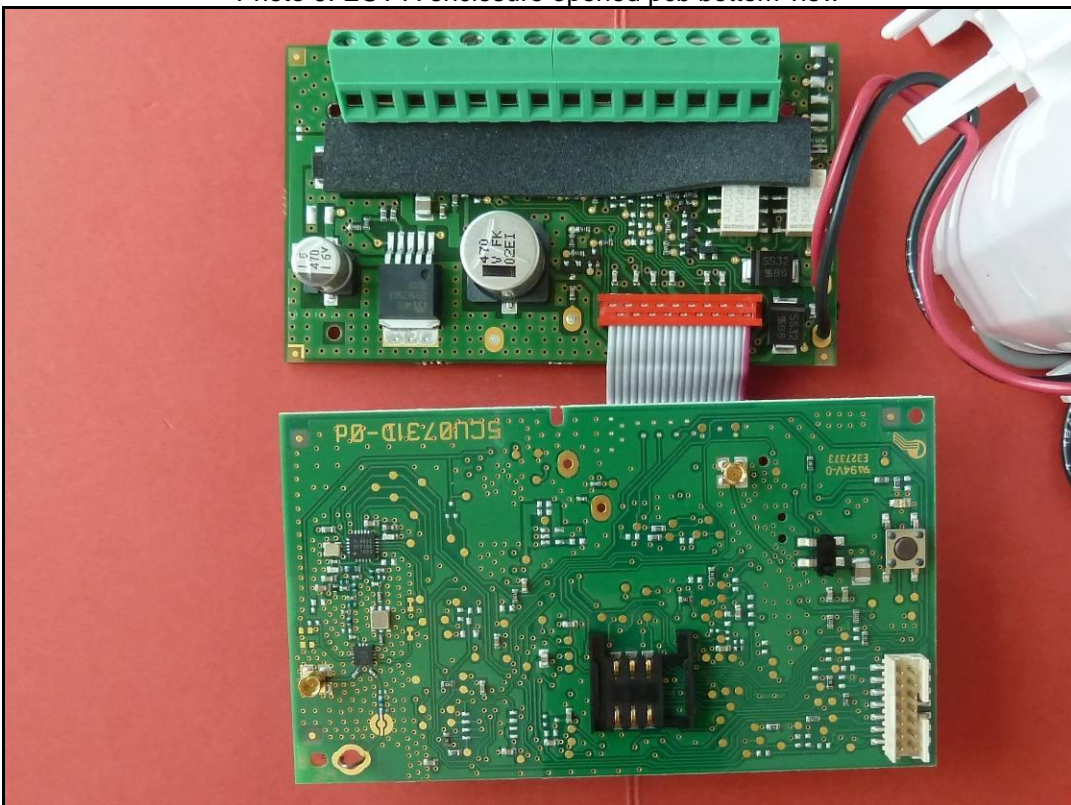

Photo 9: EUT A enclosure opened pcb bottom view



Annex C: Document history

Version	Applied changes	Date of release
-/-	Initial release	2012-03-26

Annex D: Further information**Glossary**

DUT	-	Device under Test
EMC	-	Electromagnetic Compatibility
EUT	-	Equipment under Test
FCC	-	Federal Communication Commission
FCC ID	-	Company Identifier at FCC
HW	-	Hardware
IC	-	Industry Canada
Inv. No.	-	Inventory number
N/A	-	not applicable
S/N	-	Serial Number
SW	-	Software