

TEST REPORT

Test report no.: 1-4371/12-01-20



Testing laboratory

CETECOM ICT Services GmbH
Untertuerkheimer Strasse 6 – 10
66117 Saarbruecken / Germany
Phone: + 49 681 5 98 - 0
Fax: + 49 681 5 98 - 9075
Internet: <http://www.cetecom.com>
e-mail: ict@cetecom.com

Accredited Testing Laboratory:

The testing laboratory (area of testing) is accredited according to DIN EN ISO/IEC 17025 (2005) by the Deutsche Akkreditierungsstelle GmbH (DAkkS). The accreditation is valid for the scope of testing procedures as stated in the accreditation certificate with the registration number: D-PL-12076-01-01
Area of Testing: Radio/Satellite Communications

Applicant

RSI Video Technologies
56, rue Jean Giraudoux - Bâtiment 60
67200 Strasbourg / FRANCE
Phone: +33 3 90 20 66 96
Fax: +33 3 90 20 66 36
Contact: Thierry Petri
e-mail: thierry.petri@rsivideotech.com
Phone: +33 3 90 20 66 96

Manufacturer

RSI Video Technologies
56, rue Jean Giraudoux - Bâtiment 60
67200 Strasbourg / FRANCE

Test standard/s

47 CFR Part 15 Title 47 of the Code of Federal Regulations; Chapter I
Part 15 - Radio frequency devices
RSS - 210 Issue 8 Spectrum Management and Telecommunications - Radio Standards Specification
Low-power Licence-exempt Radiocommunication Devices (All Frequency Bands):
Category I Equipment

For further applied test standards please refer to section 3 of this test report.

Test Item

Kind of test item: Wireless Alarm
Model name: BR650
FCC ID: X46BR50
IC: 8816A-BR50
Frequency: 13.56 MHz
Technology tested: RFID
Antenna: Integrated antenna
Power Supply: 3.6 V DC by Lithium battery (SAFT LS14500)
Temperature Range: -30°C to +60 °C



This test report is electronically signed and valid without handwriting signature. For verification of the electronic signatures, the public keys can be requested at the testing laboratory.

Test report authorised:



Marco Bertolino
Testing Manager

Test performed:



Andreas Luckenbill

1 Table of contents

1 Table of contents2

2 General information3

 2.1 Notes and disclaimer3

 2.2 Application details.....3

3 Test standard/s3

4 Test environment.....4

5 Test item4

6 Test laboratories sub-contracted4

7 Summary of measurement results5

8 RF measurements6

 8.1 Description of test setup6

 8.1.1 Radiated measurements.....6

 8.1.2 Conducted measurements.....7

 8.2 Additional comments7

 8.3 RSP100 test report cover sheet / performance test data8

9 Measurement results.....9

 9.1 Timing of the transmitter9

 9.2 Field strength of the fundamental10

 9.3 Field strength of the harmonics and spurious11

 9.4 Frequency tolerance15

 9.5 AC line conducted15

10 Test equipment and ancillaries used for tests16

11 Observations17

Annex A Photographs of the test setup18

Annex B External photographs of the EUT.....21

Annex C Internal photographs of the EUT24

Annex D Document history30

Annex E Further information.....30

Annex F Accreditation Certificate31

2 General information

2.1 Notes and disclaimer

The test results of this test report relate exclusively to the test item specified in this test report. CETECOM ICT Services GmbH does not assume responsibility for any conclusions and generalizations drawn from the test results with regard to other specimens or samples of the type of the equipment represented by the test item.

The test report may only be reproduced or published in full. Reproduction or publication of extracts from the report requires the prior written approval of CETECOM ICT Services GmbH.

The testing service provided by CETECOM ICT Services GmbH has been rendered under the current "General Terms and Conditions for CETECOM ICT Services GmbH".

CETECOM ICT Services GmbH will not be liable for any loss or damage resulting from false, inaccurate, inappropriate or incomplete product information provided by the customer.

Under no circumstances does the CETECOM ICT Services GmbH test report include any endorsement or warranty regarding the functionality, quality or performance of any other product or service provided.

Under no circumstances does the CETECOM ICT Services GmbH test report include or imply any product or service warranties from CETECOM ICT Services GmbH, including, without limitation, any implied warranties of merchantability, fitness for purpose, or non-infringement, all of which are expressly disclaimed by CETECOM ICT Services GmbH.

All rights and remedies regarding vendor's products and services for which CETECOM ICT Services GmbH has prepared this test report shall be provided by the party offering such products or services and not by CETECOM ICT Services GmbH.

In no case this test report can be considered as a Letter of Approval.

This test report is electronically signed and valid without handwritten signature. For verification of the electronic signatures, the public keys can be requested at the testing laboratory.

2.2 Application details

Date of receipt of order:	2012-03-06
Date of receipt of test item:	2012-04-04
Start of test:	2012-04-11
End of test:	2012-04-16
Person(s) present during the test:	-/-

3 Test standard/s

Test standard	Date	Test standard description
47 CFR Part 15	2010-10	Title 47 of the Code of Federal Regulations; Chapter I Part 15 - Radio frequency devices
RSS - 210 Issue 8	2010-12	Spectrum Management and Telecommunications - Radio Standards Specification Low-power Licence-exempt Radiocommunication Devices (All Frequency Bands): Category I Equipment

4 Test environment

Temperature:	T_{nom}	+22 °C during room temperature tests
	T_{max}	+60 °C during high temperature tests
	T_{min}	-30 °C during low temperature tests
Relative humidity content:		41 %
Barometric pressure:		not relevant for this kind of testing
Power supply:	V_{nom}	3.6 V DC by Lithium battery (SAFT LS14500)
	V_{max}	3.9 V
	V_{min}	3.3 V

5 Test item

Kind of test item	:	Wireless Alarm
Type identification	:	BR650
S/N serial number	:	Rad. 40405211800A0142
HW hardware status	:	No information available!
SW software status	:	No information available!
Frequency band [MHz]	:	13.56 MHz
Type of radio transmission	:	Modulated carrier
Use of frequency spectrum	:	
Channel access method	:	-/-
Type of modulation	:	N0N
Number of channels	:	1
Antenna	:	Integrated antenna
Power supply	:	3.6 V DC by Lithium battery (SAFT LS14500)
Temperature range	:	-30°C to +60 °C

6 Test laboratories sub-contracted

None

7 Summary of measurement results

- No deviations from the technical specifications were ascertained**
- There were deviations from the technical specifications ascertained

TC Identifier	Description	Verdict	Date	Remark
RF-Testing	CFR Part 15 RSS 210, Issue 8	Passed	2012-04-19	-/-

Test Specification Clause	Test Case	Temperature Conditions	Power Source Voltages	Pass	Fail	NA	NP	Results (max.)
§ 15.35 (c)/ RSS-GEN Issue 2	Timing of the transmitter (Duty cycle correction factor)	Nominal	Nominal	<input checked="" type="checkbox"/>	<input type="checkbox"/>	<input type="checkbox"/>	<input type="checkbox"/>	complies
§ 15.225 (a)/ RSS-210 Issue 8	Fieldstrength of Fundamental	Nominal	Nominal	<input checked="" type="checkbox"/>	<input type="checkbox"/>	<input type="checkbox"/>	<input type="checkbox"/>	complies
§ 15.209/ RSS-210 Issue 8	Fieldstrength of harmonics and spurious	Nominal	Nominal	<input checked="" type="checkbox"/>	<input type="checkbox"/>	<input type="checkbox"/>	<input type="checkbox"/>	complies
§ 15.225 (e)/ RSS-210 Issue 8	Frequency tolerance	Nominal	Extreme	<input checked="" type="checkbox"/>	<input type="checkbox"/>	<input type="checkbox"/>	<input type="checkbox"/>	complies
		Extreme	Nominal	<input checked="" type="checkbox"/>	<input type="checkbox"/>	<input type="checkbox"/>	<input type="checkbox"/>	

Note: NA = Not Applicable; NP = Not Performed

8 RF measurements

8.1 Description of test setup

8.1.1 Radiated measurements

The radiated measurements are performed in vertical and horizontal plane in the frequency range from 9 kHz to 25 GHz in semi-anechoic chambers. The EUT is positioned on a non-conductive support with a height of 0.80 m above a conductive ground plane that covers the whole chamber. The receiving antennas are confirmed with specifications ANSI C63.2-1996 clause 15 and ANSI C63.4-2003 clause 4.1.5. These antennas can be moved over the height range between 1.0 m and 4.0 m in order to search for maximum field strength emitted from EUT. The measurement distances between EUT and receiving antennas are indicated in the test setups for the various frequency ranges. For each measurement, the EUT is rotated in all three axes until the maximum field strength is received. The wanted and unwanted emissions are received by spectrum analysers where the detector modes and resolution bandwidths over various frequency ranges are set according to requirement ANSI C63-4-2003 clause 4.2. Antennas are confirmed with ANSI C63.2-1996 item 15.

Semi anechoic chamber

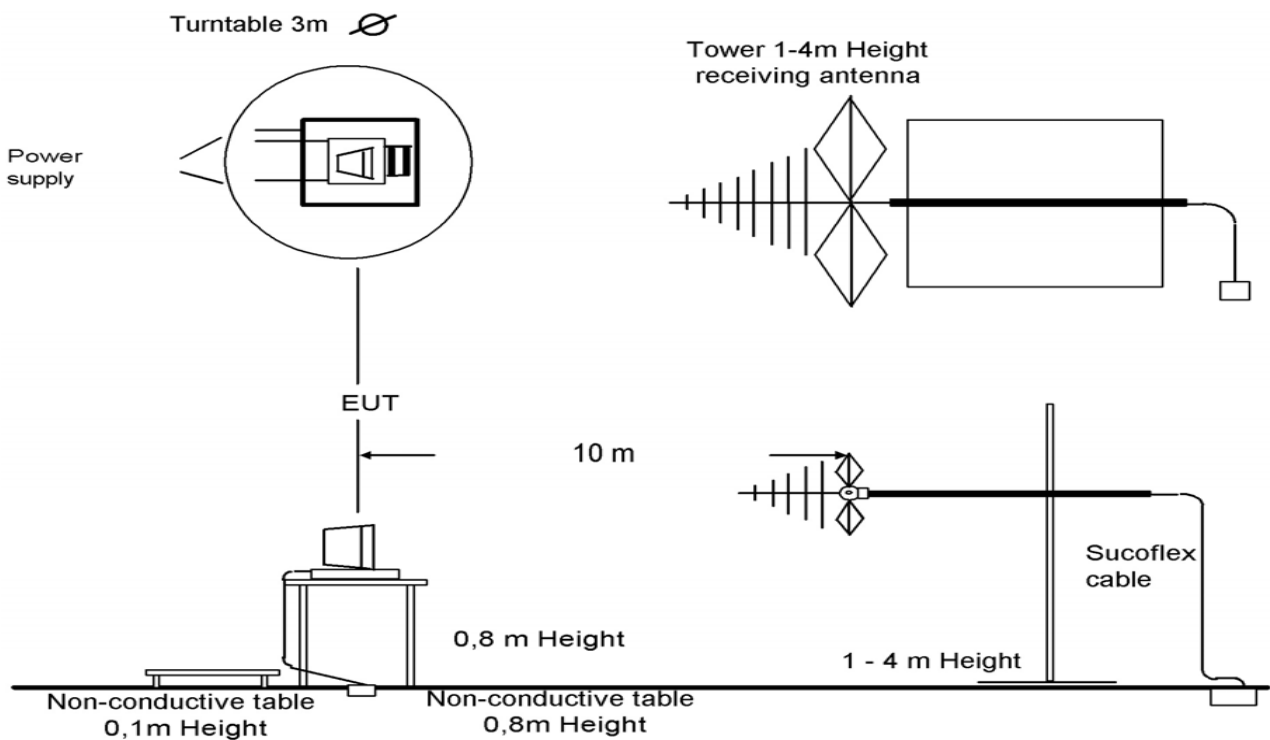

Picture 1: Diagram radiated measurements

9 kHz - 30 MHz:	active loop antenna
30 MHz – 1 GHz:	tri-log antenna
> 1 GHz:	horn antenna

The EUT is powered by an external power supply with nominal voltage. The signalling is performed from outside the chamber with a signalling unit (CMU200 or other) by air link using signalling antenna.

8.1.2 Conducted measurements

The EUT's RF signal is coupled out by the antenna connector which is supplied by the manufacturer. The signal is first 10dB attenuated before it is power divided (~6dB loss per branch). One of the signal paths is connected to the communication base Station (CMU200 or other), the other one is connected to the spectrum analyzer. The specific losses for both signal paths are first checked within a calibration. The measurement readings on the signalling unit/spectrum analyzer are corrected by the specific test set-up loss. The attenuator, power divider, signalling unit and the spectrum analyzer are impedance matched on 50 Ohm.

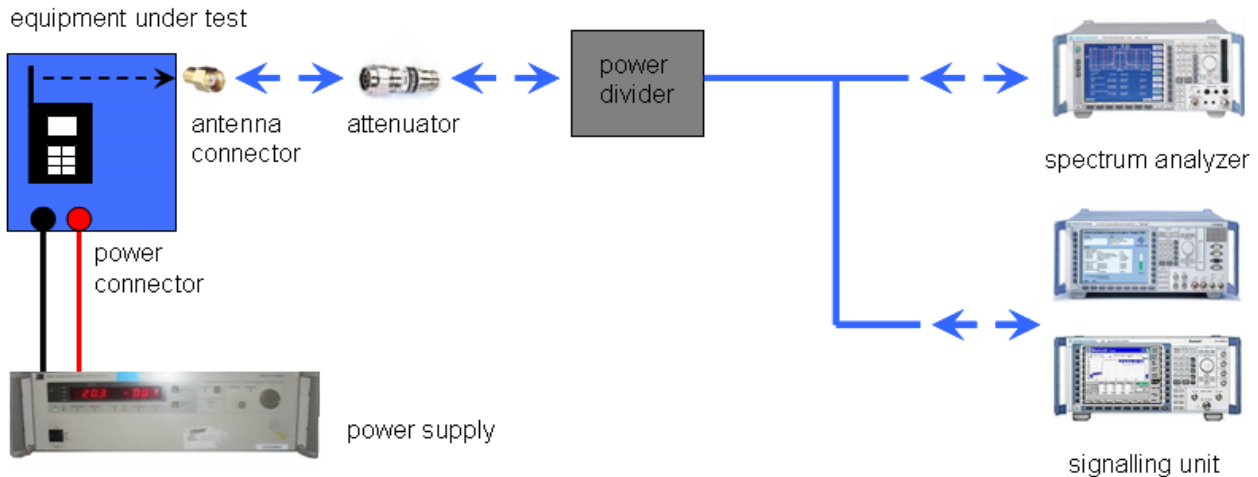

Picture 2: Diagram conducted measurements

8.2 Additional comments

Reference documents: None

Special test descriptions: None

Configuration descriptions: None

8.3 RSP100 test report cover sheet / performance test data

Test Report Number	:	1-4371/12-01-20
Equipment Model Number	:	BR650
Certification Number	:	8816A-BR50
Manufacturer (complete Address)	:	RSI Video Technologies 56, rue Jean Giraudoux - Bâtiment 60 67200 Strasbourg / FRANCE
Tested to radio standards specification no.	:	RSS 210, Issue 8
Open Area Test Site IC No.	:	IC 3462C-1
Frequency Range or fixed frequency	:	13.56 MHz
Field Strength [dB μ V/m] (at which distance)	:	58 dB μ V/m @ 10m
Occupied bandwidth (99%-BW) [Hz]	:	16 kHz
Type of modulation	:	N0N
Emission Designator (TRC-43)	:	16K0N0N
Antenna Information	:	Integrated antenna
Transmitter Spurious (worst case) [dB μ V/m @ 3m]:		63 dB μ V/m
Receiver Spurious (worst case) [dB μ V/m @ 3m]:		No idle mode

ATTESTATION:

DECLARATION OF COMPLIANCE:

I attest that the testing was performed or supervised by me; that the test measurements were made in accordance with the above-mentioned Industry Canada standard(s); and that the equipment identified in this application has been subjected to all the applicable test conditions specified in the Industry Canada standards and all of the requirements of the standard have been met.

Laboratory Manager:

2012-04-19
Date

Andreas Luckenbill
Name

Signature

9 Measurement results

9.1 Timing of the transmitter

Measurement:

Measurement parameter	
Detector:	-/-
Sweep time:	-/-
Resolution bandwidth:	-/-
Video bandwidth:	-/-
Span:	-/-
Trace-Mode:	-/-

Limits:

FCC	IC
Timing of the transmitter	
<p>(c) Unless otherwise specified, e.g. Section 15.255(b), when the radiated emission limits are expressed in terms of the average value of the emission, and pulsed operation is employed, the measurement field strength shall be determined by averaging over one complete pulse train, including blanking intervals, as long as the pulse train does not exceed 0.1 seconds. As an alternative (provided the transmitter operates for longer than 0.1 seconds) or in cases where the pulse train exceeds 0.1 seconds, the measured field strength shall be determined from the average absolute voltage during a 0.1 second interval during which the field strength is at its maximum value. The exact method of calculating the average field strength shall be submitted with any application for certification or shall be retained in the measurement data file for equipment subject to notification or verification.</p>	

Duty cycle 100%.

Result: passed

9.2 Field strength of the fundamental

Measurement:

Measurement parameter	
Detector:	Quai Peak
Sweep time:	Auto
Resolution bandwidth:	200 Hz up to 150 kHz, 9 kHz up to 30 MHz, 120 kHz up to 1 GHz
Video bandwidth:	≥ RBW
Span:	10 kHz
Trace-Mode:	Max Hold

Limits:

FCC		IC
Fundamental Frequency (MHz)	Field strength of Fundamental ($\mu\text{V/m}$)	Measurement distance (m)
13.553 to 13.567	15848 $\mu\text{V/m}$ (84 $\text{dB}\mu\text{V/m}$)	30
	158489 $\mu\text{V/m}$ (104 $\text{dB}\mu\text{V/m}$)	10 (Recalculated acc. to FCC part15.31 (f2))

Result:

TEST CONDITIONS		MAXIMUM POWER ($\text{dB}\mu\text{V/m}$)	
Frequency		13.56 MHz	13.56 MHz
Mode		at 10 m distance	at 30 m distance
T_{nom}	V_{nom}	58 $\text{dB}\mu\text{V/m}$	38 $\text{dB}\mu\text{V/m}$ *
Measurement uncertainty		±3dB	

* Limits recalculated from 10m to 30m with 40 dB/decade according to FCC 15.31 (f2).

Result: passed

9.3 Field strength of the harmonics and spurious

Measurement:

Measurement parameter	
Detector:	Quasi Peak / Average
Sweep time:	Auto
Resolution bandwidth:	200 Hz up to 150 kHz, 9 kHz up to 30 MHz, 120 kHz up to 1 GHz
Video bandwidth:	≥ RBW
Span:	Steps 100 MHz
Trace-Mode:	Max hold

Limits:

FCC		IC	
Field strength of the harmonics and spurious.			
Frequency (MHz)	Field strength (µV/m)	Measurement distance (m)	
0.0009 – 0.490	2400/F(kHz)	300	
0.490 – 1.705	24000/F(kHz)	30	
1.705 – 30	30 (29.5 dBµV/m)	30	
30 – 88	100 (40 dBµV/m)	3	
88 – 216	150 (43.5 dBµV/m)	3	
216 – 960	200 (46 dBµV/m)	3	

Result:

EMISSION LIMITATIONS				
f [MHz]	Detector	Limit max. allowed [dBµV/m]	Amplitude of emission [dBµV/m]	Results
No peaks detected!				

Result: passed

Plots of the measurements

Plot 1: 9 kHz – 30 MHz;

Part 15.209 Magnetics, Measurement distance 3m

Transmit frequency 13.56 MHz

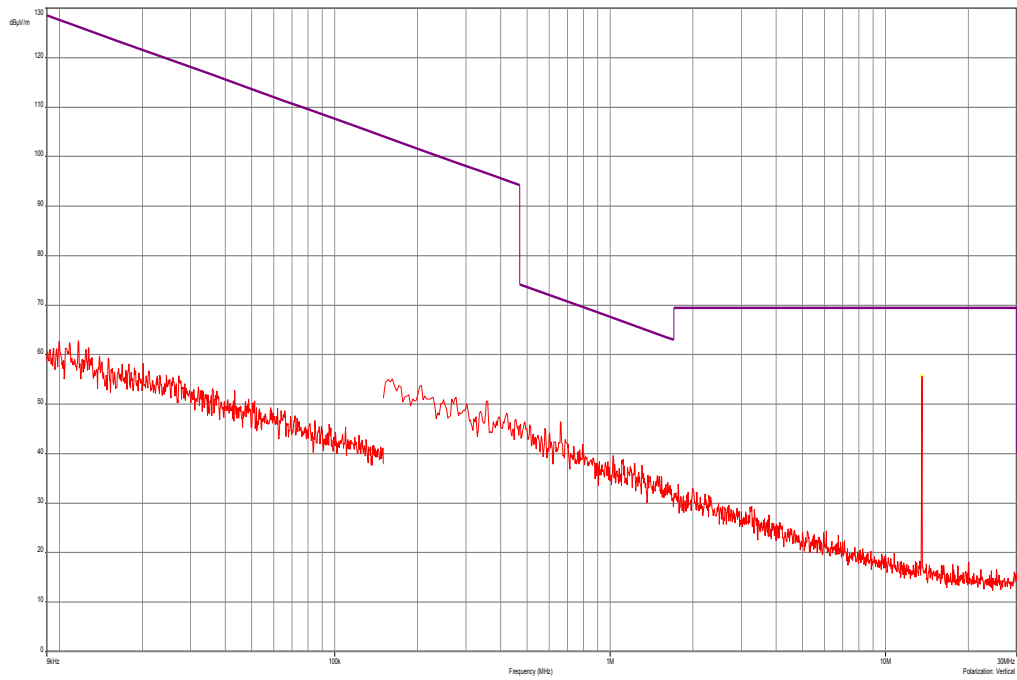

Plot 2: 30 MHz – 1000 MHz

Transmit frequency 13.56 MHz

Common Information

EUT:	BR651
Serial Number:	40405211800A0142
Test Description:	FCC part 15 B class B
Operating Conditions:	cont TX 13,56 MHz
Operator Name:	Hennemann
Comment:	battery powered

Scan Setup: STAN_Fin [EMI radiated]

Hardware Setup:	Electric Field (NOS)				
Receiver:	[ESCI 3]				
Level Unit:	dBµV/m				
Subrange	Step Size	Detectors	IF BW	Meas. Time	Preamp
30 MHz - 2 GHz	60 kHz	QPK	120 kHz	1 s	20 dB

FCC_10m(B)_3

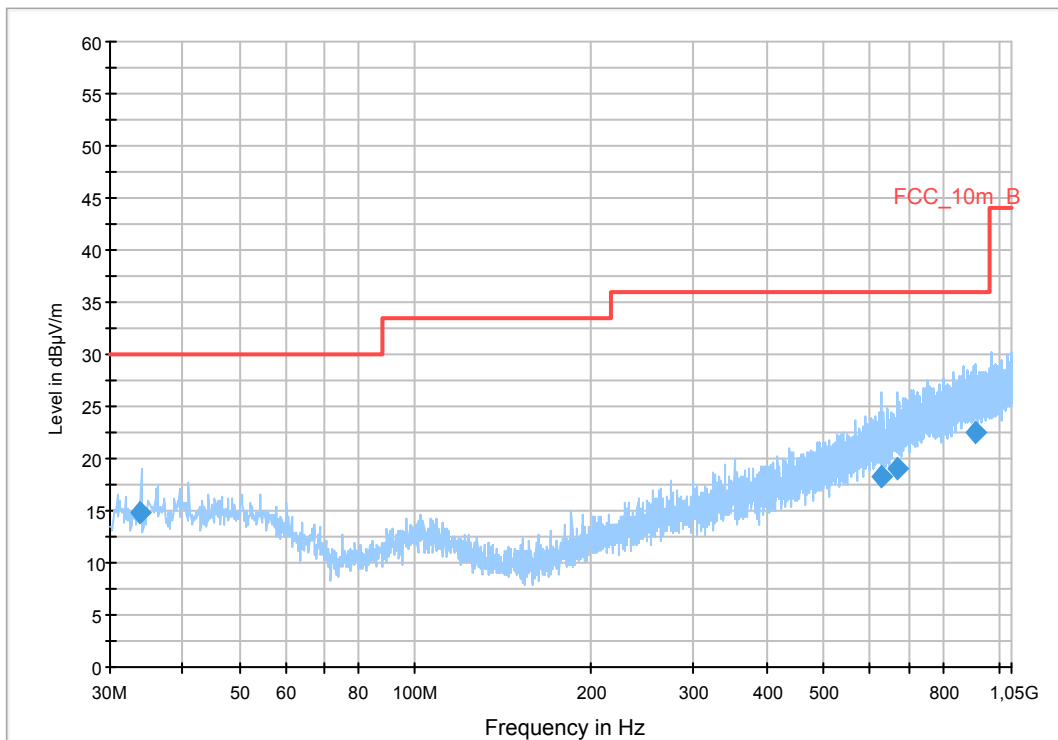

Final Result 1

Frequency (MHz)	QuasiPeak (dBµV/m)	Meas. Time (ms)	Bandwidth (kHz)	Height (cm)	Polarization	Azimuth (deg)	Corr. (dB)	Margin (dB)	Limit (dBµV/m)	Comment
33.876900	14.8	1000.0	120.000	104.0	V	191.0	12.9	15.2	30.0	
627.565466	18.3	1000.0	120.000	146.0	H	262.0	21.0	17.7	36.0	
671.234100	19.1	1000.0	120.000	208.0	V	18.0	21.7	16.9	36.0	
907.831450	22.5	1000.0	120.000	307.0	H	112.0	25.2	13.5	36.0	

Plot 3: Spectrum mask part 15.225 (a, b, c, d)

Limits recalculated from 30m to 3m with 40 dB/decade according to FCC 15.31 (f2)

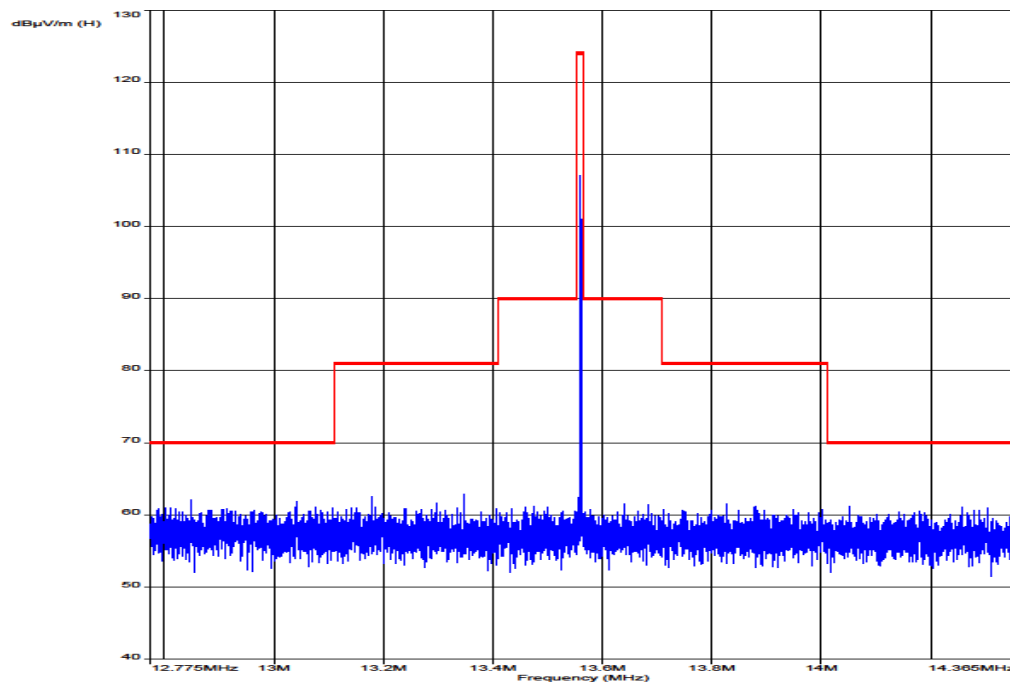

The transmitter holds the requirements of FCC 15.225 (a, b, c and d)

9.4 Frequency tolerance

Measurement:

Measurement parameter	
Detector:	Peak
Sweep time:	Auto
Resolution bandwidth:	100 Hz
Video bandwidth:	300 Hz
Span:	30 kHz
Trace-Mode:	Max hold

Limits:

FCC	IC
<p>The frequency tolerance of the carrier signal shall be maintained within +/- 0.01% of the operating frequency over a temperature variation of -20 degrees to +50 degrees C at normal supply voltage, and for a variation in the primary supply voltage from 85% to 115% of the rated supply voltage at a temperature of 20 degrees C.</p>	

Result: **passed**

Frequency tolerance								
Over temperature variation			Over voltage variation			MHz		
Limit is +/- 1.356 kHz			Limit is +/- 1.356 kHz					
T (°C)]	Frequency	result	Power voltage	Frequency	result	F [MHz]	Detector	Level [µV/m]
-30°	13.56015	Pass	3.3 V	13.56006	Pass			
-20°	13.56018	Pass	3.4 V	13.56006	Pass			
-10°	13.56021	Pass	3.5 V	13.56006	Pass			
0°	13.56018	Pass	3.6 V	13.56006	Pass			
10°	13.56012	Pass	3.7 V	13.56006	Pass			
20°	13.56006	Pass	3.8 V	13.56006	Pass			
30°	13.56000	Pass	3.9 V	13.56006	Pass			
40°	13.55994	Pass						
50°	13.55991	Pass						
60°	13.55988	Pass						
Measurement uncertainty			±100 Hz					

9.5 AC line conducted

Not applicable!

10 Test equipment and ancillaries used for tests

Typically, the calibrations of the test apparatus are commissioned to and performed by an accredited calibration laboratory. The calibration intervals are determined in accordance with the DIN EN ISO/IEC 17025. In addition to the external calibrations, the laboratory executes comparison measurements with other calibrated test systems or effective verifications. Weekly chamber inspections and range calibrations are performed. Where possible, rf-generating and signalling equipment as well as measuring receivers and analyzers are connected to an external high-precision 10 MHz reference (GPS-based or rubidium frequency standard).

In order to simplify the identification of the equipment used at some special tests, some items of test equipment and ancillaries can be provided with an identifier or number in the equipment list below (Labor/Item).

No.	Lab / Item	Equipment	Type	Manufact.	Serial No.	INV. No Cetecom	Kind of Calibration	Last Calibration	Next Calibration
11	n. a.	DC Power Supply 0 – 32V	1108-32	Heiden	001802	300001383	Ve	23.06.2010	23.06.2013
2	n. a.	Temperature Test Chamber	T-40/50	CTS GmbH	064023	300003540	vIKI!	20.09.2011	20.09.2013
3	n. a.	Coaxial Attenuator 30dB/500W	8325	Bird	1530	300001595	ev		
4	n. a.	Double-Ridged Waveguide Horn Antenna 1-18.0GHz	3115	EMCO	8812-3088	300001032	vIKI!	11.05.2011	11.05.2013
5	n. a.	Active Loop Antenna	6502	EMCO	2210	300001015	ne		
6	n. a.	Anechoic chamber	FAC 3/5m	MWB / TDK	87400/02	300000996		23.03.2009	
7	n. a.	Relais Matrix	3488A	HP Meßtechnik	2719A15013	300001156	ne		
8	n. a.	Three-Way Power Splitter, 50 Ohm	11850C	HP Meßtechnik		300000997	ne		
9	n. a.	Switch / Control Unit	3488A	HP	2605e08770	300001443	ne		
10	n. a.	TRILOG Broadband Test-Antenna 30 MHz - 3 GHz	VULB9163	Schwarzbeck	371	300003854	vIKI!	14.10.2011	14.10.2014
11	n. a.	MXE EMI Receiver 20 Hz bis 26,5 GHz	N9038A	Agilent Technologies	MY51210197	3000042xx	k	19.12.2011	19.12.2012
12	n. a.	Spectrum Analyzer 20 Hz - 50 GHz	FSU50	R&S	200012	300003443	ve	01.07.2010	01.07.2012
13	45	Switch-Unit	3488A	HP Meßtechnik	2719A14505	300000368	g		
14	50	DC power supply, 60Vdc, 50A, 1200 W	6032A	HP Meßtechnik	2920A04466	300000580	ne		
15	n. a.	software	SPS_PHE 1.4f	Spitzberger & Spieß	B5981; 5D1081; B5979	300000210	ne		
16	n. a.	EMI Test Receiver	ESCI 1166.5950.03	R&S	100083	300003312	k	04.01.2012	04.01.2014
17	n. a.	Analyser-Reference-System (Harmonics and Flicker)	ARS 16/1	SPS	A3509 07/0 0205	300003314	k	14.07.2011	14.07.2013
18	n. a.	Amplifier	JS42-00502650-28-5A	MITEQ	1084532	300003379	ev		
19	n. a.	Antenna Tower	Model 2175	ETS-LINDGREN	64762	300003745	izw		
20	n. a.	Positioning Controller	Model 2090	ETS-LINDGREN	64672	300003746	izw		
21	n. a.	Turntable Interface-Box	Model 105637	ETS-LINDGREN	44583	300003747	izw		
22	n. a.	TRILOG Broadband Test-Antenna 30 MHz - 3 GHz	VULB9163	Schwarzbeck	295	300003787	k	01.04.2010	
23	n. a.	Spectrum-Analyser	FSU26	R&S	200809	300003874	k	06.01.2012	06.01.2014

Agenda: Kind of Calibration

k	calibration / calibrated	EK	limited calibration
ne	not required (k, ev, izw, zw not required)	zw	cyclical maintenance (external cyclical maintenance)
ev	periodic self verification	izw	internal cyclical maintenance
Ve	long-term stability recognized	g	blocked for accredited testing
vkI!	Attention: extended calibration interval		
NK!	Attention: not calibrated	*)	next calibration ordered / currently in progress

11 Observations

No observations exceeding those reported with the single test cases have been made.

Annex A Photographs of the test setup

Photo documentation:

Photo 1:

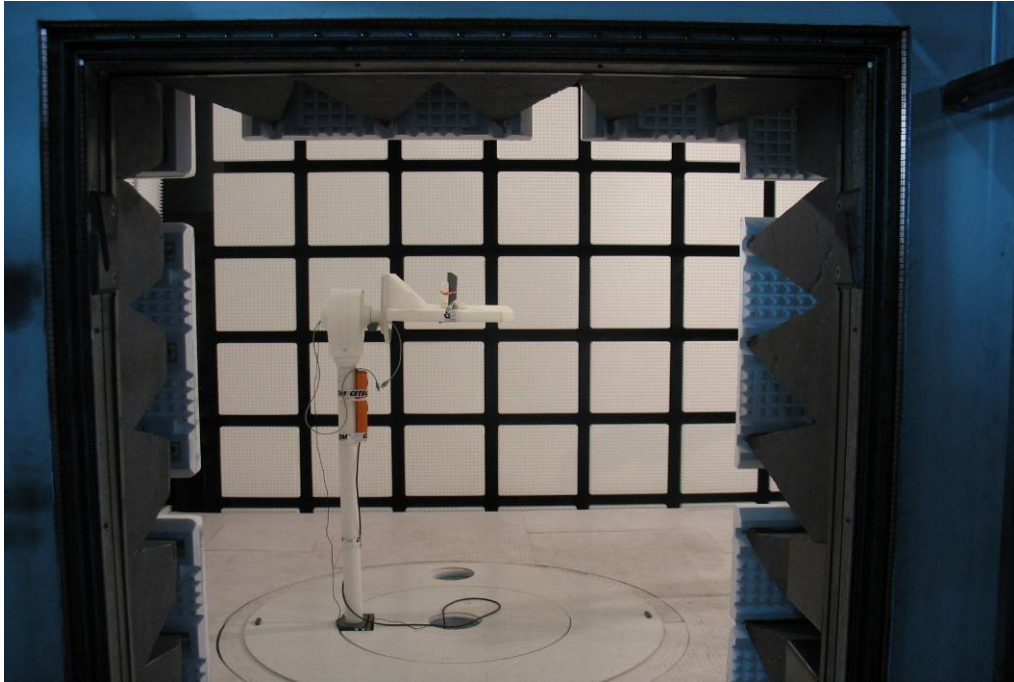

Photo 2:



Photo 3:



Photo 4:

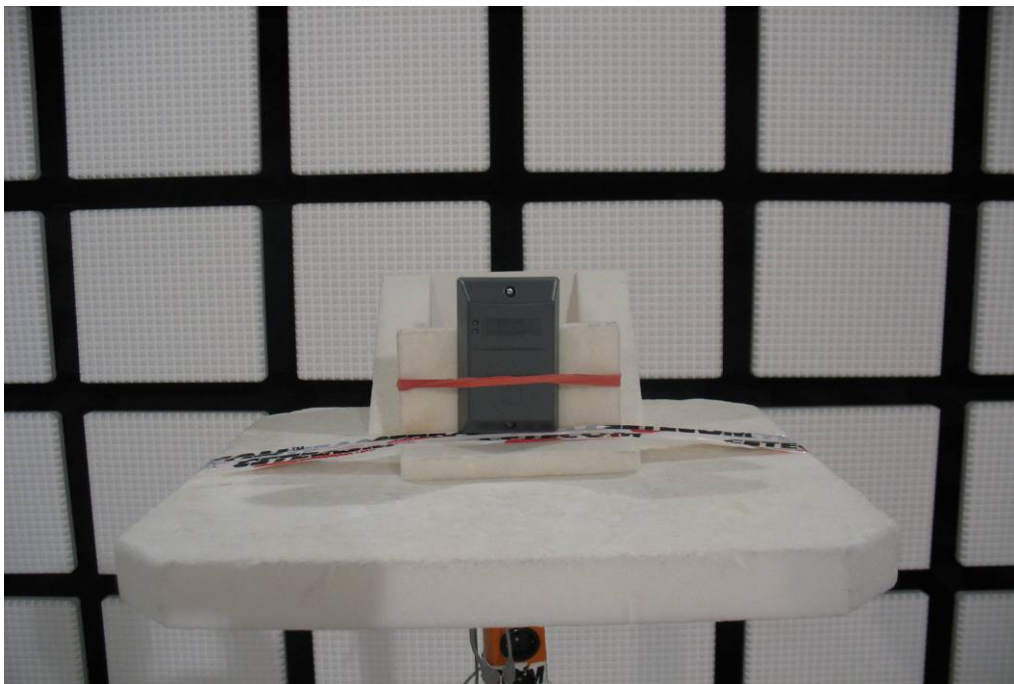
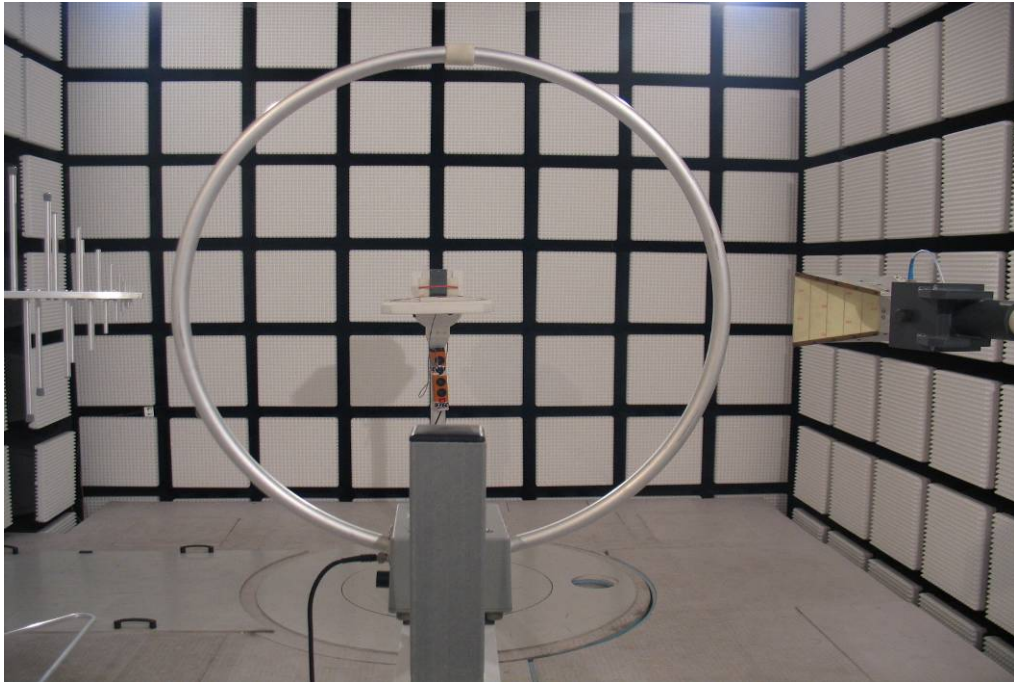

Photo 5:



Annex B External photographs of the EUT

Photo documentation:

Photo 1:



Photo 2:



Photo 3:



Photo 4:



Photo 5:



Annex C Internal photographs of the EUT

Photo documentation:

Photo 1:



Photo 2:



Photo 3:



Photo 4:



Photo 5:



Photo 6:



Photo 7:



Photo 8:



Photo 9:

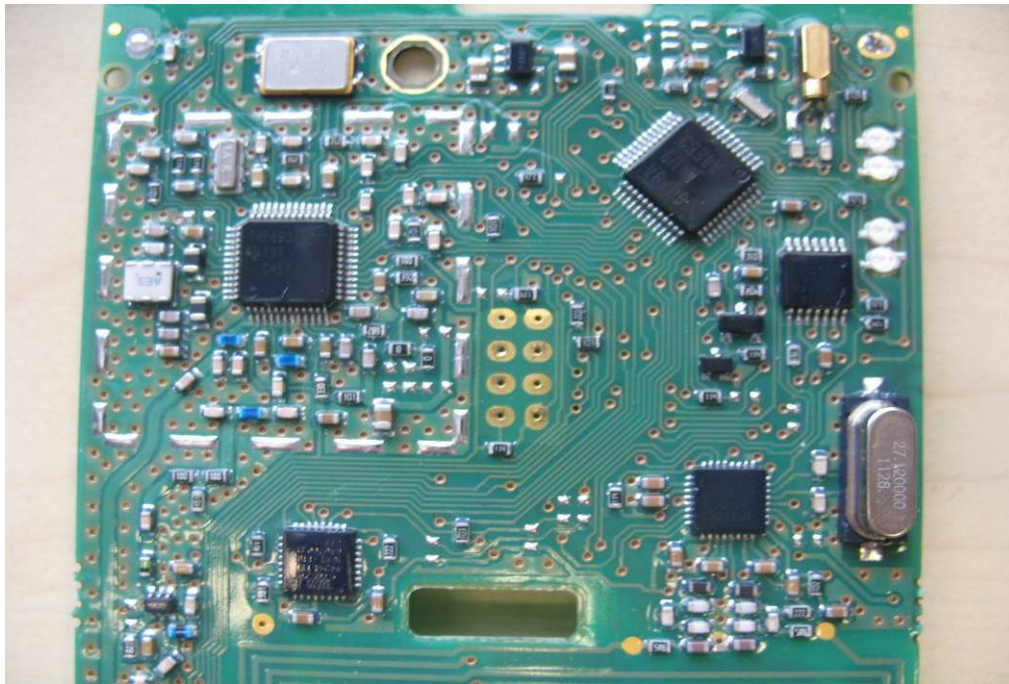

Photo 10:



Photo 11:

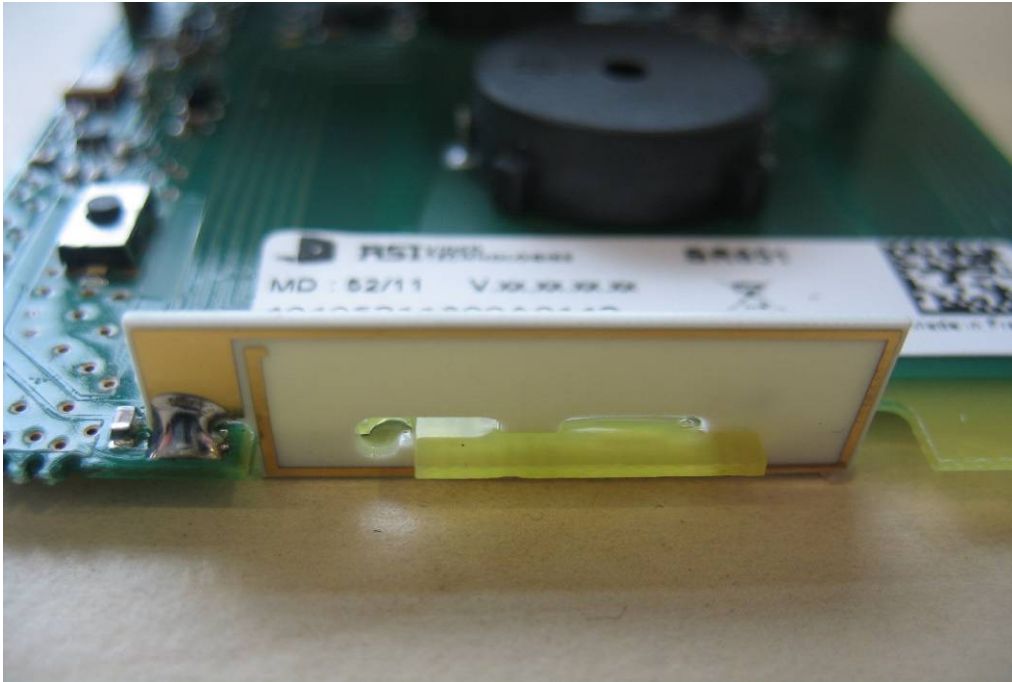

Photo 12:



Annex D Document history

Version	Applied changes	Date of release
1.0	Initial release	2012-04-19

Annex E Further information**Glossary**

AVG	-	Average
DUT	-	Device under test
EMC	-	Electromagnetic Compatibility
EN	-	European Standard
EUT	-	Equipment under test
ETSI	-	European Telecommunications Standard Institute
FCC	-	Federal Communication Commission
FCC ID	-	Company Identifier at FCC
HW	-	Hardware
IC	-	Industry Canada
Inv. No.	-	Inventory number
N/A	-	Not applicable
PP	-	Positive peak
QP	-	Quasi peak
S/N	-	Serial number
SW	-	Software

Annex F Accreditation Certificate



Deutsche Akkreditierungsstelle GmbH
German Accreditation Body

Entrusted according to Section 8 subsection 1 AkkStelleG in connection with Section 1 subsection 1 AkkStelleGBV
Signatory to the Multilateral Agreements of EA, ILAC and IAF for Mutual Recognition

Accreditation



The Deutsche Akkreditierungsstelle GmbH (German Accreditation Body) attests that the testing laboratory

CETECOM ICT Services GmbH
Untertürkheimer Straße 6-10
66117 Saarbrücken

is competent under the terms of DIN EN ISO/IEC 17025:2005 to carry out tests in the following fields:

- Wired communications and DECT
- Acoustic
- Radio
- Shirt Range Devices (SRD)
- RFID
- WiMax and Richtfunk
- Mobile radio (GSM / DCS), Over the Air (OTA) Performance
- Electromagnetic Compatibility (EMC) incl. Automotive
- Product safety
- SAR and Hearing Aid Compatibility (HAC)
- Environmental simulation
- Smart Card Terminals
- Bluetooth
- Wi-Fi-Services

The accreditation certificate shall only apply in connection with the notice of accreditation of 13.04.2011 with the accreditation number D-PL-12076-01 and is valid until 03.09.2014. It comprises the cover sheet, the reverse side of the cover sheet and the following annex with a total of 82 pages.

Registration number of the certificate: **D-PL-12076-01-01**

Frankfurt am Main, 13.04.2011

[Signature]
Dipl.-Ing. (FH) Ralf Egner
Head of Division 2

This document is a translation. The definitive version is the original German accreditation certificate.
www.dakks.de

Deutsche Akkreditierungsstelle GmbH

Office Berlin
Spittelmarkt 10
10117 Berlin

Office Frankfurt am Main
Gartenstraße 6
60594 Frankfurt am Main

Office Braunschweig
Bundesallee 100
38116 Braunschweig

The publication of extracts of the accreditation certificate is subject to the prior written approval by Deutsche Akkreditierungsstelle GmbH (DAkkS). Exempted is the unchanged form of separate disseminations of the cover sheet by the conformity assessment body mentioned overleaf.

No impression shall be made that the accreditation also extends to fields beyond the scope of accreditation attested by DAkkS.

The accreditation was granted pursuant to the Act on the Accreditation Body (AkkStelleG) of 31 July 2009 (Federal Law Gazette I p. 2625) and the Regulation (EC) No 765/2008 of the European Parliament and of the Council of 9 July 2008 setting out the requirements for accreditation and market surveillance relating to the marketing of products (Official Journal of the European Union L 218 of 9 July 2008; p. 30). DAkkS is a signatory to the Multilateral Agreements for Mutual Recognition of the European co-operation for Accreditation (EA), International Accreditation Forum (IAF) and International Laboratory Accreditation Cooperation (ILAC). The signatories to these agreements recognise each other's accreditations.

The up-to-date state of membership can be retrieved from the following websites:
EA: www.european-accreditation.org
ILAC: www.ilac.org
IAF: www.iaf.nu

Front side of certificate

Back side of certificate

Note:

The current certificate including annex is published on our website (see link below) or may be received from CETECOM ICT Services on request.

http://www.cetecom.com/fileadmin/de/CETECOM_D_Saarbruecken/accreditations_Jan_2010/DAKKS_Akkredi_Urk_EN17025-En_incl_Annex.pdf