



# MEASUREMENT REPORT

## FCC PART 15.407 WLAN 802.11a/n

---

**FCC ID:** X3ZWFMOD10

**APPLICANT:** Amp'ed RF Technology, Inc.

**Application Type:** Certification

**Product:** Dual band wifi module

**Model No.:** WF60

**Brand Name:** Amp'ed RF

**FCC Classification:** Unlicensed National Information Infrastructure (NII)

**FCC Rule Part(s):** Part15 Subpart E (Section 15.407)

**Test Procedure(s):** ANSI C63.10-2013, KDB 789033 D02v02r01

**Test Date:** November 15, 2018 ~ December 19, 2018

Reviewed By:



(Kevin Guo)

Approved By:

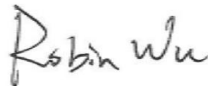

(Robin Wu)



The test results relate only to the samples tested.

This equipment has been shown to be capable of compliance with the applicable technical standards as indicated in the measurement report and was tested in accordance with the measurement procedures specified in KDB 789033 D02v02r01. Test results reported herein relate only to the item(s) tested.

The test report shall not be reproduced except in full without the written approval of MRT Technology (Suzhou) Co., Ltd.

### Revision History

Report No.	Version	Description	Issue Date	Note
1811WSU012-U2	Rev. 01	Initial report	12-28-2018	Valid

---

## CONTENTS

Description	Page
<b>§2.1033 General Information .....</b>	<b>6</b>
<b>1. INTRODUCTION .....</b>	<b>7</b>
1.1. Scope .....	7
1.2. MRT Test Location .....	7
<b>2. PRODUCT INFORMATION .....</b>	<b>8</b>
2.1. Equipment Description.....	8
2.2. Product Specification Subjective to this Report.....	8
2.3. Working Frequencies for this report.....	9
2.4. Description of Available Antennas .....	9
2.5. Description of Antenna RF Port .....	9
2.6. Test Mode .....	10
2.7. Description of Test Software .....	10
2.8. Device Capabilities .....	11
2.9. Test Configuration .....	12
2.10. EMI Suppression Device(s)/Modifications.....	12
2.11. Labeling Requirements.....	12
<b>3. DESCRIPTION OF TEST .....</b>	<b>13</b>
3.1. Evaluation Procedure .....	13
3.2. AC Line Conducted Emissions .....	13
3.3. Radiated Emissions.....	14
<b>4. TEST EQUIPMENT CALIBRATION DATE .....</b>	<b>15</b>
<b>5. MEASUREMENT UNCERTAINTY.....</b>	<b>16</b>
<b>6. TEST RESULT .....</b>	<b>17</b>
6.1. Summary .....	17
6.2. 26dB Bandwidth Measurement.....	18
6.2.1. Test Limit .....	18
6.2.2. Test Procedure used.....	18
6.2.3. Test Setting.....	18
6.2.4. Test Setup .....	18
6.2.5. Test Result.....	19
6.3. 6dB Bandwidth Measurement.....	22
6.3.1. Test Limit .....	22
6.3.2. Test Procedure used.....	22

---

6.3.3. Test Setting.....	22
6.3.4. Test Setup .....	22
6.3.5. Test Result.....	23
6.4. Output Power Measurement.....	25
6.4.1. Test Limit .....	25
6.4.2. Test Procedure Used .....	25
6.4.3. Test Setting.....	25
6.4.4. Test Setup .....	25
6.4.5. Test Result.....	26
6.5. Transmit Power Control .....	28
6.5.1. Test Limit .....	28
6.5.2. Test Procedure Used .....	28
6.5.3. Test Setting.....	28
6.5.4. Test Setup .....	28
6.5.5. Test Result.....	28
6.6. Power Spectral Density Measurement.....	29
6.6.1. Test Limit .....	29
6.6.2. Test Procedure Used .....	29
6.6.3. Test Setting.....	29
6.6.4. Test Setup .....	30
6.6.5. Test Result.....	31
6.7. Frequency Stability Measurement.....	34
6.7.1. Test Limit .....	34
6.7.2. Test Procedure Used .....	34
6.7.3. Test Setup .....	34
6.7.4. Test Result.....	35
6.8. Radiated Spurious Emission Measurement.....	36
6.8.1. Test Limit .....	36
6.8.2. Test Procedure Used .....	36
6.8.3. Test Setting.....	36
6.8.4. Test Setup .....	38
6.8.5. Test Result.....	40
6.9. Radiated Restricted Band Edge Measurement .....	54
6.9.1. Test Limit .....	54
6.9.2. Test Procedure Used .....	55
6.9.3. Test Setting.....	55
6.9.4. Test Setup .....	56
6.9.5. Test Result.....	57
6.10. AC Conducted Emissions Measurement.....	73

6.10.1. Test Limit .....	73
6.10.2. Test Procedure .....	73
6.10.3. Test Setup .....	74
6.10.4. Test Result.....	75
<b>7. CONCLUSION.....</b>	<b>77</b>
<b>Appendix A - Test Setup Photograph .....</b>	<b>78</b>
<b>Appendix B - EUT Photograph.....</b>	<b>79</b>

## §2.1033 General Information

<b>Applicant:</b>	Amp'ed RF Technology, Inc.
<b>Applicant Address:</b>	1879 Lundy Ave, Suite 138, San Jose, CA, 95131
<b>Manufacturer:</b>	Amp'ed RF Technology, Inc.
<b>Manufacturer Address:</b>	1879 Lundy Ave, Suite 138, San Jose, CA, 95131
<b>Test Site:</b>	MRT Technology (Suzhou) Co., Ltd
<b>Test Site Address:</b>	D8 Building, No.2 Tian'edang Rd., Wuzhong Economic Development Zone, Suzhou, China
<b>FCC Registration No.:</b>	893164
<b>Test Device Serial No.:</b>	N/A <input type="checkbox"/> Production <input checked="" type="checkbox"/> Pre-Production <input type="checkbox"/> Engineering

### Test Facility / Accreditations

Measurements were performed at MRT Laboratory located in Tian'edang Rd., Suzhou, China.

- MRT facility is a FCC registered (MRT Reg. No. 893164) test facility with the site description report on file and has met all the requirements specified in ANSI C63.4-2014.
- MRT facility is an IC registered (MRT Reg. No. 11384A-1) test laboratory with the site description on file at Industry Canada.
- MRT facility is a VCCI registered (R-20025, G-20034, C-20020, T-20020) test laboratory with the site description on file at VCCI Council.
- MRT Lab is accredited to ISO 17025 by the American Association for Laboratory Accreditation (A2LA) under the American Association for Laboratory Accreditation Program (A2LA Cert. No. 3628.01) in EMC, Telecommunications, Radio and SAR testing.



# 1. INTRODUCTION

## 1.1. Scope

Measurement and determination of electromagnetic emissions (EMC) of radio frequency devices including intentional and/or unintentional radiators for compliance with the technical rules and regulations of the Federal Communications Commission and the Industry Canada Certification and Engineering Bureau.

## 1.2. MRT Test Location

The map below shows the location of the MRT LABORATORY, its proximity to the Taihu Lake. These measurement tests were conducted at the MRT Technology (Suzhou) Co., Ltd. Facility located at D8 Building, No.2 Tian'edang Rd., Wuzhong Economic Development Zone, Suzhou, China. The measurement facility compliant with the test site requirements specified in ANSI C63.4-2014.



## 2. PRODUCT INFORMATION

### 2.1. Equipment Description

Product Name:	Dual band wifi module
Model No.:	WF60
Brand Name:	Amp'ed RF
Wi-Fi Specification:	802.11a/b/g/n-HT20

### 2.2. Product Specification Subjective to this Report

Frequency Range:	For 802.11a/n-HT20: 5180~5240MHz, 5745~5825MHz
Type of Modulation:	802.11a/n: OFDM
Data Rate:	802.11a: 6/9/12/18/24/36/48/54Mbps 802.11n: up to 65Mbps

Note: For other features of this EUT, test report will be issued separately.



### 2.3. Working Frequencies for this report

802.11a/n-HT20

Channel	Frequency	Channel	Frequency	Channel	Frequency
36	5180 MHz	40	5200 MHz	44	5220 MHz
48	5240 MHz	149	5745 MHz	153	5765 MHz
157	5785 MHz	161	5805 MHz	165	5825 MHz
--	--	--	--	--	--

### 2.4. Description of Available Antennas

Antenna Specification				
Model Name	Type	Frequency Band	Connector	Max. Peak Gain
146153	FPC Antenna	2400-2480	ipex	3.0
		5150-5250, 5725-5850	ipex	4.5

### 2.5. Description of Antenna RF Port

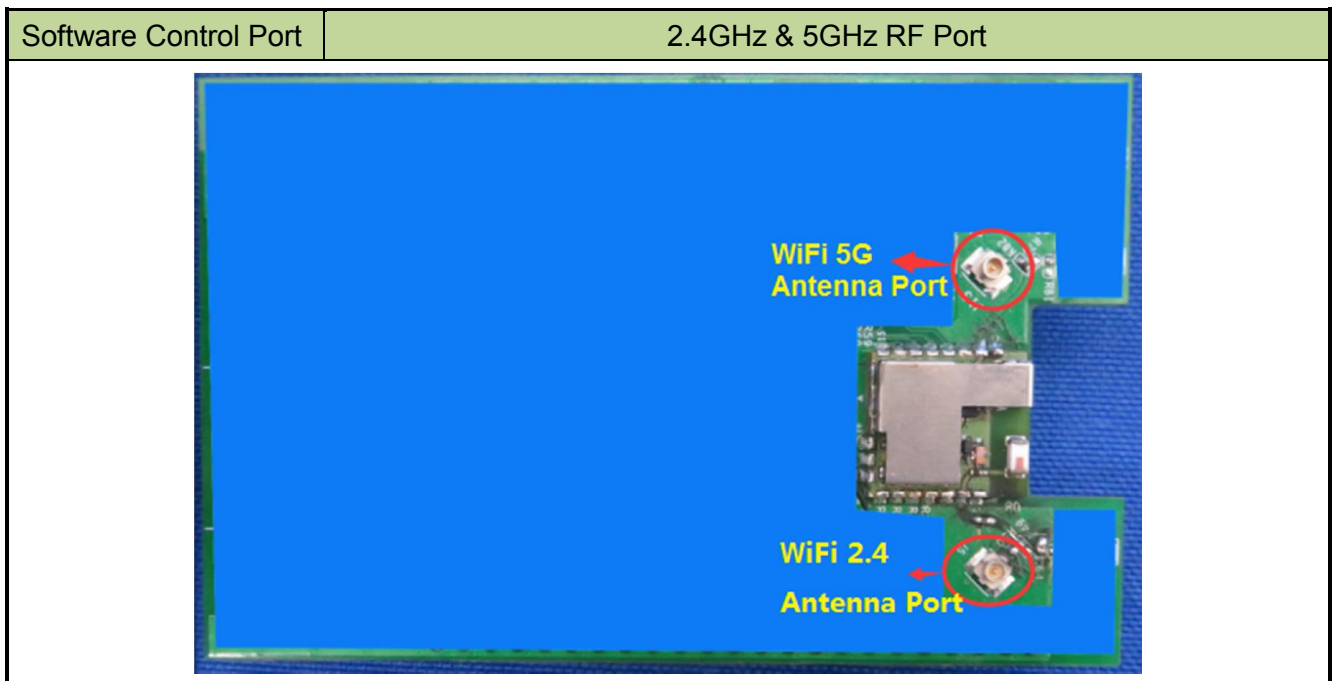

## 2.6. Test Mode

Test Mode	Mode 1: Transmit by 802.11a (6Mbps)
	Mode 2: Transmit by 802.11n-HT20 (MCS0)

## 2.7. Description of Test Software

The test utility software used during testing was “etf”, and the version was “ETF\_GUI\_A40.00.0007”.

### Power Parameter Value:

Test Mode	Test Frequency (MHz)	Power Parameter Value
802.11a	5180	18
	5220	18
	5240	18
	5745	18
	5785	18
	5825	18
802.11n-HT20	5180	18
	5220	18
	5240	18
	5745	18
	5785	18
	5825	18

## 2.8. Device Capabilities

This device contains the following capabilities:

2.4GHz WLAN (DTS), 5GHz WLAN (NII)

**Note:** 5GHz (NII) operation is possible in 20MHz channel bandwidths. The maximum achievable duty cycles for all modes were determined based on measurements performed on a spectrum analyzer in zero-span mode with RBW = 8MHz, VBW = 50MHz. The RBW and VBW were both greater than 50/T, where T is the minimum transmission duration, and the number of sweep points across T was greater than 100. The duty cycles are as follows:

Model No.	Test Mode	Duty Cycle
WF60	802.11a	97.61%
	802.11n-HT20	97.48%

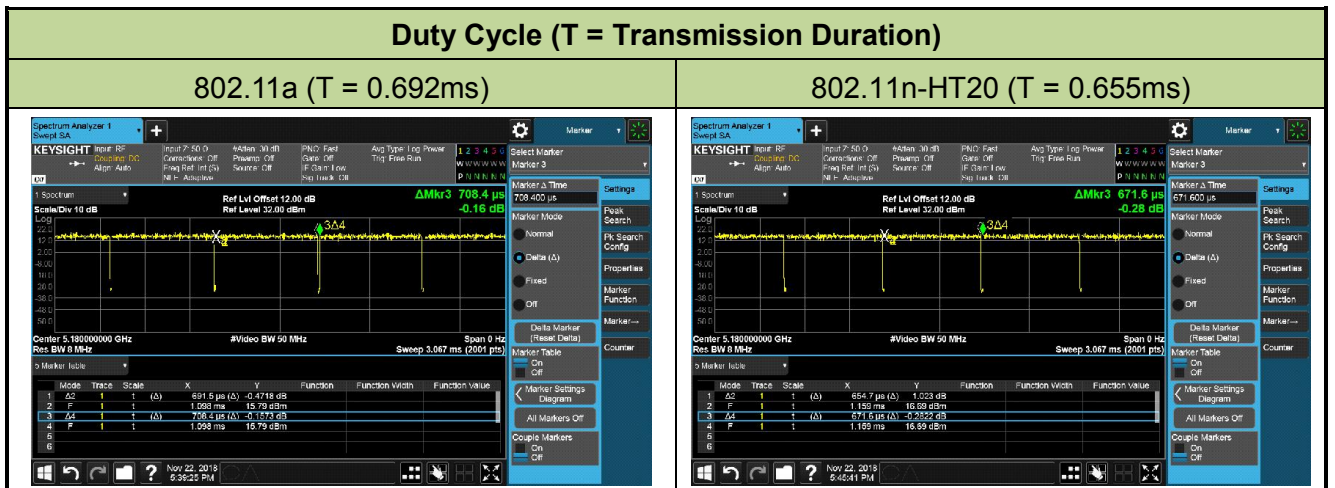

## 2.9. Test Configuration

The **Dual band wifi module** was tested per the guidance of KDB 789033 D02v02r01. ANSI C63.10-2013 was used to reference the appropriate EUT setup for radiated spurious emissions testing and AC line conducted testing.

## 2.10. EMI Suppression Device(s)/Modifications

No EMI suppression device(s) were added and/or no modifications were made during testing.

## 2.11. Labeling Requirements

Per 2.1074 & 15.19; Docket 95-19

The label shall be permanently affixed at a conspicuous location on the device; instruction manual or pamphlet supplied to the user and be readily visible to the purchaser at the time of purchase. However, when the device is so small wherein placement of the label with specified statement is not practical, only the FCC ID must be displayed on the device per Section 15.19(a)(5). Please see attachment for FCC ID label and label location.

### 3. DESCRIPTION OF TEST

#### 3.1. Evaluation Procedure

The measurement procedures described in the American National Standard for Testing Unlicensed Wireless Devices (ANSI C63.10-2013), and the guidance provided in KDB 789033 D02v02r01 were used in the measurement of the **Dual band wifi module**.

**Deviation from measurement procedure.....None**

#### 3.2. AC Line Conducted Emissions

The line-conducted facility is located inside an 8'x4'x4' shielded enclosure. A 1m x 2m wooden table 80cm high is placed 40cm away from the vertical wall and 80cm away from the sidewall of the shielded room. Two 10kHz-30MHz, 50Ω/50uH Line-Impedance Stabilization Networks (LISNs) are bonded to the shielded room floor. Power to the LISNs is filtered by external high-current high-insertion loss power line filters. These filters attenuate ambient signal noise from entering the measurement lines. These filters are also bonded to the shielded enclosure.

The EUT is powered from one LISN and the support equipment is powered from the second LISN. All interconnecting cables more than 1 meter were shortened to a 1 meter length by non-inductive bundling (serpentine fashion) and draped over the back edge of the test table. All cables were at least 40cm above the horizontal reference ground-plane. Power cables for support equipment were routed down to the second LISN while ensuring that that cables were not draped over the second LISN.

Sufficient time for the EUT, support equipment, and test equipment was allowed in order for them to warm up to their normal operating condition. The RF output of the LISN was connected to the receiver and exploratory measurements were made to determine the frequencies producing the maximum emission from the EUT. The receiver was scanned from 150kHz to 30MHz. The detector function was set to peak mode for exploratory measurements while the bandwidth of the analyzer was set to 9kHz. The EUT, support equipment, and interconnecting cables were arranged and manipulated to maximize each emission. Each emission was also maximized by varying: power lines, the mode of operation or data exchange speed, or support equipment whichever determined the worst-case emission. Once the worst case emissions have been identified, the one EUT cable configuration/arrangement and mode of operation that produced these emissions are used for final measurements on the same test site. The analyzer is set to CISPR quasi-peak and average detectors with a 9kHz resolution bandwidth for final measurements.

An extension cord was used to connect to a single LISN which powered by EUT. The extension cord was calibrated with LISN, the impedance and insertion loss are compliance with the requirements as stated in ANSI C63.10-2013.

### 3.3. Radiated Emissions

The radiated test facilities consisted of an indoor 3 meter semi-anechoic chamber used for final measurements and exploratory measurements, when necessary. The measurement area is contained within the semi-anechoic chamber which is shielded from any ambient interference. For measurements above 1GHz absorbers are arranged on the floor between the turn table and the antenna mast in such a way so as to maximize the reduction of reflections. For measurements below 1GHz, the absorbers are removed. A MF Model 210SS turntable is used for radiated measurement. It is a continuously rotatable, remotecontrolled, metallic turntable and 2 meters (6.56 ft.) in diameter. The turn table is flush with the raised floor of the chamber in order to maintain its function as a ground plane. An 80cm high PVC support structure is placed on top of the turntable.

For all measurements, the spectrum was scanned through all EUT azimuths and from 1 to 4 meter receive antenna height using a broadband antenna from 30MHz up to the upper frequency shown in 15.33(b)(1) depending on the highest frequency generated or used in the device or on which the device operates or tunes. For frequencies above 1GHz, linearly polarized double ridge horn antennas were used. For frequencies below 30MHz, a calibrated loop antenna was used. When exploratory measurements were necessary, they were performed at 1 meter test distance inside the semi-anechoic chamber using broadband antennas, broadband amplifiers, and spectrum analyzers to determine the frequencies and modes producing the maximum emissions. Sufficient time for the EUT, support equipment, and test equipment was allowed in order for them to warm up to their normal operating condition. The test set-up for frequencies below 1GHz was placed on top of the 0.8 meter high, 1 x 1.5 meter table; and test set-up for frequencies 1-40GHz was placed on top of the 1.5 meter high, 1 x 1.5 meter table. The EUT, support equipment, and interconnecting cables were arranged and manipulated to maximize each emission. Appropriate precaution was taken to ensure that all emissions from the EUT were maximized and investigated. The system configuration, clock speed, mode of operation or video resolution, if applicable, turntable azimuth, and receive antenna height was noted for each frequency found.

Final measurements were made in the semi-anechoic chamber using calibrated, linearly polarized broadband and horn antennas. The test setup was configured to the setup that produced the worst case emissions. The spectrum analyzer was set to investigate all frequencies required for testing to compare the highest radiated disturbances with respect to the specified limits. The turntable containing the EUT was rotated through 360 degrees and the height of the receive antenna was varied 1 to 4 meters and stopped at the azimuth and height producing the maximum emission. Each emission was maximized by changing the orientation of the EUT through three orthogonal planes and changing the polarity of the receive antenna, whichever produced the worst-case emissions. According to 3dB Beam-Width of horn antenna, the horn antenna should be always directed to the EUT when rising height.

#### 4. TEST EQUIPMENT CALIBRATION DATE

##### Conducted Emissions - SR2

Instrument	Manufacturer	Type No.	Asset No.	Cali. Interval	Cali. Due Date
EMI Test Receiver	R&S	ESR3	MRTSUE06185	1 year	2019/04/20
Two-Line V-Network	R&S	ENV 216	MRTSUE06002	1 year	2019/06/15
Two-Line V-Network	R&S	ENV 216	MRTSUE06003	1 year	2019/06/15
Thermohygrometer	Testo	608-H1	MRTSUE06404	1 year	2019/08/15
Shielding Anechoic Chamber	Mikebang	Chamber-SR2	MRTSUE06214	N/A	N/A

##### Radiated Emissions – AC1

Instrument	Manufacturer	Type No.	Asset No.	Cali. Interval	Cali. Due Date
MXE EMI Receiver	Agilent	N9038A	MRTSUE06125	1 year	2019/08/14
EXA Signal Analyzer	Keysight	N9010B	MRTSUE06452	1 year	2019/07/20
Loop Antenna	Schwarzbeck	FMZB 1519	MRTSUE06025	1 year	2019/11/20
Bilog Period Antenna	Schwarzbeck	VULB 9162	MRTSUE06022	1 year	2019/10/21
Broad Band Horn Antenna	Schwarzbeck	BBHA 9120D	MRTSUE06171	1 year	2019/11/18
Broad Band Horn Antenna	Schwarzbeck	BBHA 9170	MRTSUE06024	1 year	2019/12/14
Broadband Coaxial Preamp	Agilent	BBV 9718	MRTSUE06176	1 year	2019/11/17
Preamp	Schwarzbeck	BBV 9721	MRTSUE06121	1 year	2019/06/13
Digital Thermometer & Hygrometer	MingGao	ETH529	MRTSUE06170	1 year	2019/12/12
Anechoic Chamber	RIKEN	Chamber-AC2	MRTSUE06213	1 year	2019/05/02

##### Conducted Test Equipment - TR3

Instrument	Manufacturer	Type No.	Asset No.	Cali. Interval	Cali. Due Date
EXA Signal Analyzer	KEYSIGHT	N9020A	MRTSUE06106	1 year	2019/04/20
EXA Signal Analyzer	Keysight	N9010B	MY57110481	1 year	2019/07/20
USB wideband power sensor	KEYSIGHT	U2021XA	MRTSUE0644	1 year	2019/07/20
Temperature & Humidity Chamber	BAOYT	BYH-150CL	MRTSUE06051	1 year	2019/12/06
Thermohygrometer	testo	608-H1	MRTSUE06401	1 year	2019/08/15

Software	Version	Function
e3	V 8.3.5	EMI Test Software

## 5. MEASUREMENT UNCERTAINTY

Where relevant, the following test uncertainty levels have been estimated for tests performed on the EUT as specified in CISPR 16-4-2. This uncertainty represents an expanded uncertainty expressed at approximately the 95% confidence level using a coverage factor of  $k = 2$ .

<b>AC Conducted Emission Measurement - SR2</b>
Measuring Uncertainty for a Level of Confidence of 95% ( $U=2Uc(y)$ ): 150kHz~30MHz: 3.46dB
<b>Radiated Emission Measurement – AC1</b>
Measuring Uncertainty for a Level of Confidence of 95% ( $U=2Uc(y)$ ): 9kHz ~ 1GHz: 4.18dB 1GHz ~ 40GHz: 4.76dB
<b>Output Power - TR3</b>
Measuring Uncertainty for a Level of Confidence of 95% ( $U=2Uc(y)$ ): 1.13dB
<b>Power Spectrum Density - TR3</b>
Measuring Uncertainty for a Level of Confidence of 95% ( $U=2Uc(y)$ ): 1.15dB
<b>Occupied Bandwidth - TR3</b>
Measuring Uncertainty for a Level of Confidence of 95% ( $U=2Uc(y)$ ): 0.28%



## 6. TEST RESULT

### 6.1. Summary

**Product Name:** Dual band wifi module

**FCC ID:** X3ZWFMOD10

FCC Section(s)	Test Description	Test Limit	Test Condition	Test Result	Reference
15.407(a)	26dB Bandwidth	N/A	Conducted	Pass	Section 6.2
15.407(e)	6dB Bandwidth	≥ 500kHz		Pass	Section 6.3
15.407(a)(1)(ii), (2), (3)	Maximum Conducted Output Power	Refer to section 6.4		Pass	Section 6.4
15.407(h)(1)	Transmit Power Control	≤ 24 dBm		N/A	Section 6.5
15.407(a)(1)(ii), (2), (3), (5)	Peak Power Spectral Density	Refer to Section 6.6		Pass	Section 6.6
15.407(g)	Frequency Stability	± 20 ppm		Pass	Section 6.7
15.407(b)(1), (4)(i)	Undesirable Emissions	Refer to Section 6.8	Radiated	Pass	Section 6.8 & 6.9
15.205, 15.209 15.407(b)(5), (6), (7)	General Field Strength Limits(Restricted Bands andRadiated Emission Limits)	Emissions in restrictedbands must meet theradiated limits detailed in15.209		Pass	
15.207	AC Conducted Emissions 150kHz - 30MHz	< FCC 15.207 limits	Line Conducted	Pass	Section 6.10

Notes:

- 1) The analyzer plots shown in this section were all taken with a correction table loaded into the analyzer. The correction table was used to account for the losses of the cables and attenuators used as part of the system to connect the EUT to the analyzer at all frequencies of interest.
- 2) All modes of operation and data rates were investigated. For radiated emission test, every axis (X, Y, Z) was also verified. The test results shown in the following sections represent the worst case emissions.

## 6.2. 26dB Bandwidth Measurement

### 6.2.1. Test Limit

N/A

### 6.2.2. Test Procedure used

KDB 789033 D02v02r01 - Section C.1

### 6.2.3. Test Setting

1. The analyzers' automatic bandwidth measurement capability was used to perform the 26dB bandwidth measurement. The "X" dB bandwidth parameter was set to  $X = 26$ . The automatic bandwidth measurement function also has the capability of simultaneously measuring the 99% occupied bandwidth. The bandwidth measurement was not influenced by any intermediated power nulls in the fundamental emission.
2. RBW = approximately 1% of the emission bandwidth.
3. VBW  $\geq 3 \times$  RBW.
4. Detector = Peak.
5. Trace mode = max hold.

### 6.2.4. Test Setup

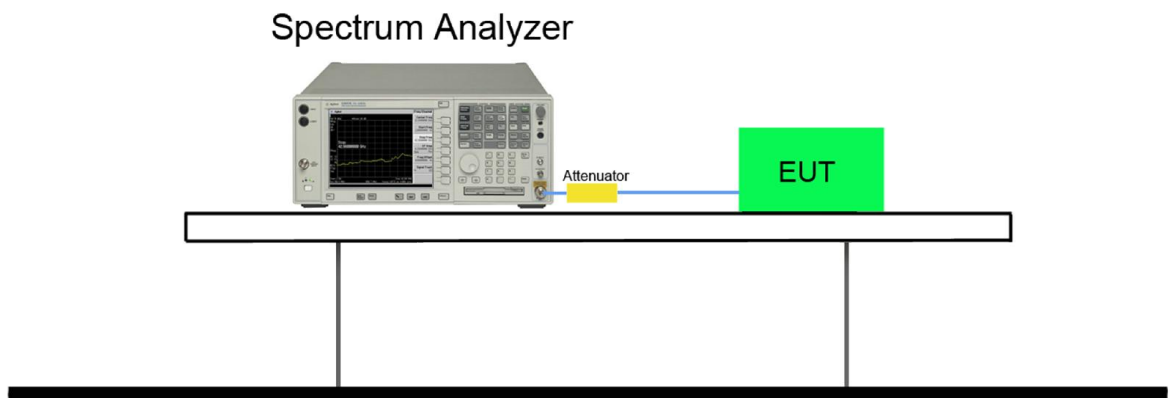

### 6.2.5. Test Result

Product	Dual band wifi module	Temperature	24°C
Test Engineer	Jone Zhang	Relative Humidity	59%
Test Site	TR3	Test Date	2018/11/19

Test Mode	Data Rate/ MCS	Channel No.	Frequency (MHz)	26dB Bandwidth (MHz)	99% Bandwidth (MHz)
802.11a	6Mbps	36	5180	26.88	16.93
802.11a	6Mbps	44	5220	26.55	16.87
802.11a	6Mbps	48	5240	25.81	16.85
802.11a	6Mbps	149	5745	20.72	16.71
802.11a	6Mbps	157	5785	20.76	16.70
802.11a	6Mbps	165	5825	22.14	16.71
802.11n-HT20	MCS0	36	5180	26.64	17.87
802.11n-HT20	MCS0	44	5220	26.77	17.86
802.11n-HT20	MCS0	48	5240	26.71	17.84
802.11n-HT20	MCS0	149	5745	20.44	17.77
802.11n-HT20	MCS0	157	5785	20.79	17.75
802.11n-HT20	MCS0	165	5825	21.94	17.76

802.11a 26dB Bandwidth & 99% Bandwidth

Channel 36 (5180MHz)

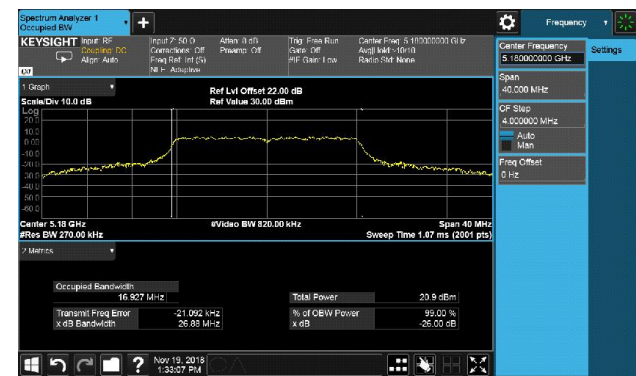

Channel 44 (5220MHz)

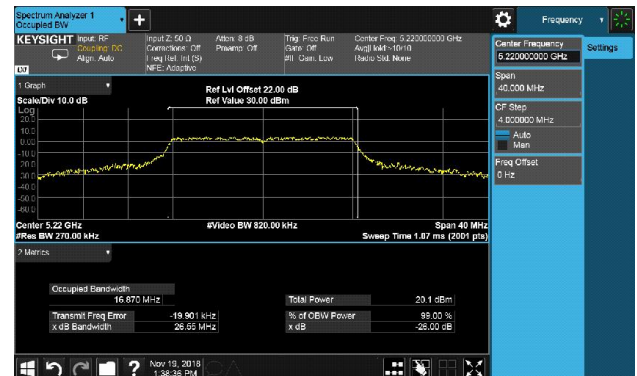

Channel 48 (5240MHz)

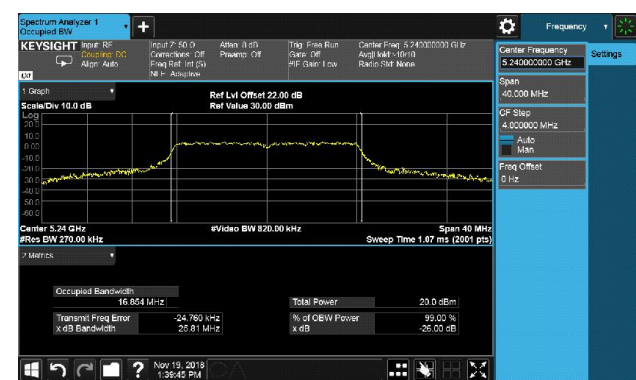

Channel 149 (5745MHz)

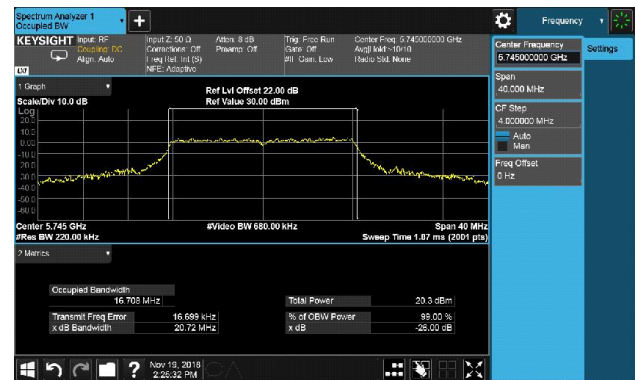

Channel 157 (5785MHz)

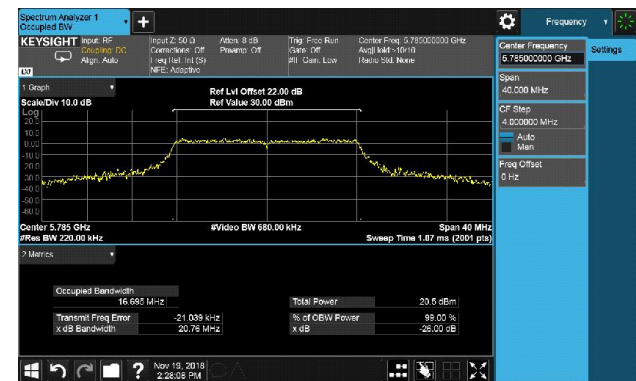

Channel 165 (5825MHz)

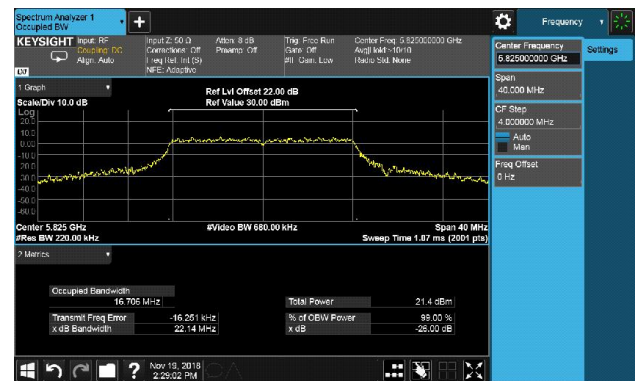

802.11n-HT20 26dB Bandwidth & 99% Bandwidth

Channel 36 (5180MHz)



Channel 44 (5220MHz)

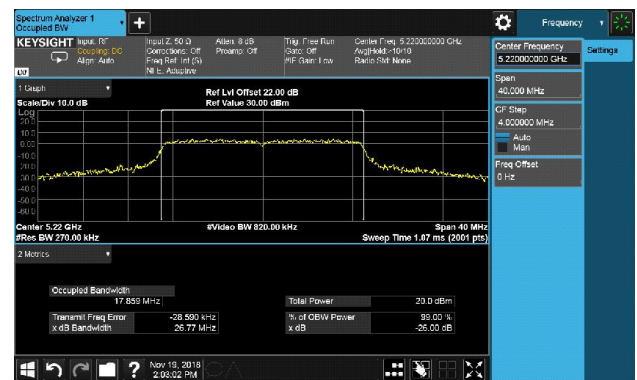

Channel 48 (5240MHz)

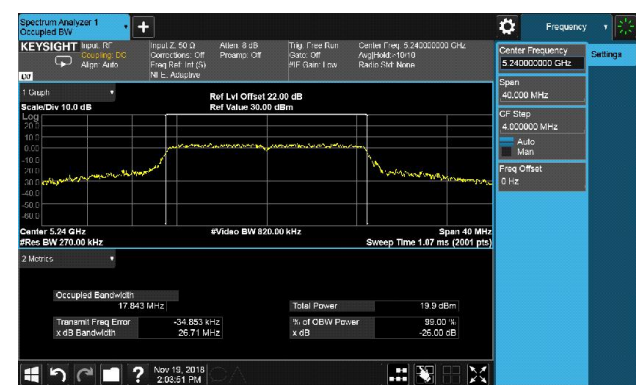

Channel 149 (5745MHz)



Channel 157 (5785MHz)



Channel 165 (5825MHz)



### 6.3. 6dB Bandwidth Measurement

#### 6.3.1. Test Limit

The minimum 6dB bandwidth shall be at least 500 kHz.

#### 6.3.2. Test Procedure used

KDB 789033 D02v02r01 - Section C.2

#### 6.3.3. Test Setting

1. Set center frequency to the nominal EUT channel center frequency.
2. RBW = 100 kHz.
3. VBW  $\geq 3 \times$  RBW.
4. Detector = Peak.
5. Trace mode = max hold.
6. Sweep = auto couple.
7. Allow the trace to stabilize.
8. Measure the maximum width of the emission that is constrained by the frequencies associated with the two outermost amplitude points (upper and lower frequencies) that are attenuated by 6 dB relative to the maximum level measured in the fundamental emission.

#### 6.3.4. Test Setup

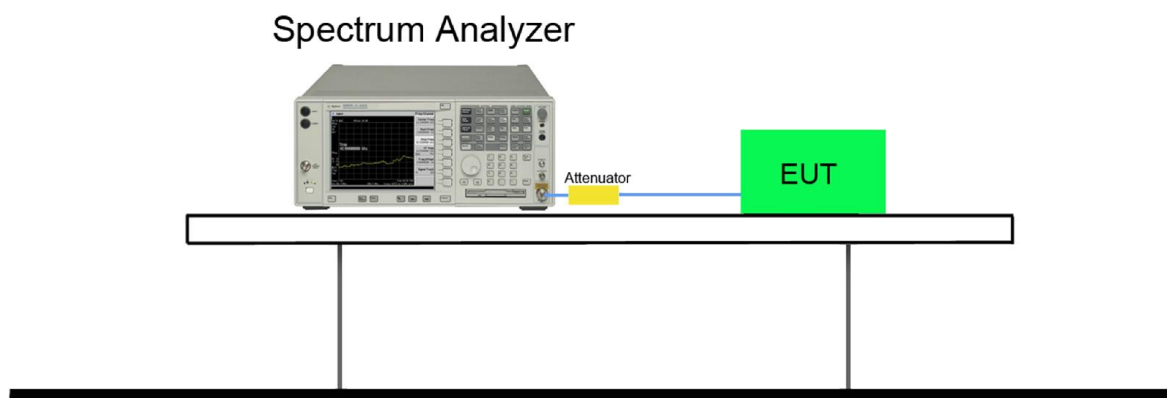

### 6.3.5. Test Result

Product	Dual band wifi module	Temperature	24°C
Test Engineer	Jone Zhang	Relative Humidity	59%
Test Site	TR3	Test Date	2018/11/19

Test Mode	Data Rate/MCS	Channel No.	Frequency (MHz)	6dB Bandwidth (MHz)	Limit (MHz)	Result
802.11a	6Mbps	149	5745	16.33	≥ 0.5	Pass
802.11a	6Mbps	157	5785	16.34	≥ 0.5	Pass
802.11a	6Mbps	165	5825	16.33	≥ 0.5	Pass
802.11n-HT20	MCS0	149	5745	17.55	≥ 0.5	Pass
802.11n-HT20	MCS0	157	5785	17.17	≥ 0.5	Pass
802.11n-HT20	MCS0	165	5825	17.28	≥ 0.5	Pass





802.11n-HT20 6dB Bandwidth

Channel 149 (5745MHz)

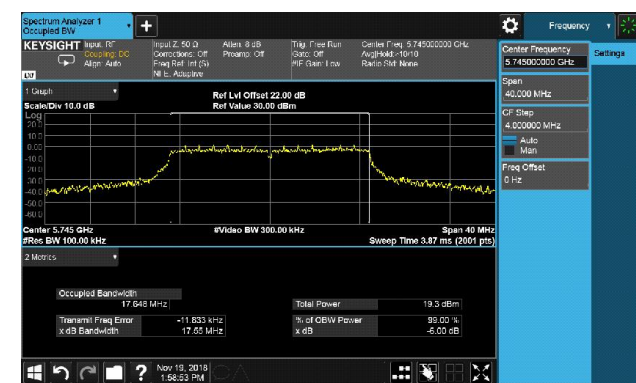

Channel 157 (5785MHz)

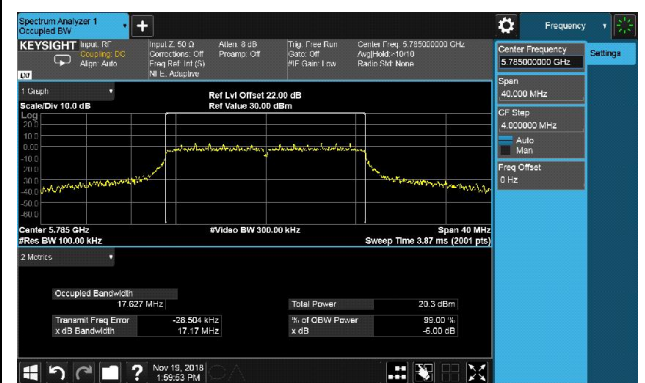

Channel 165 (5825MHz)

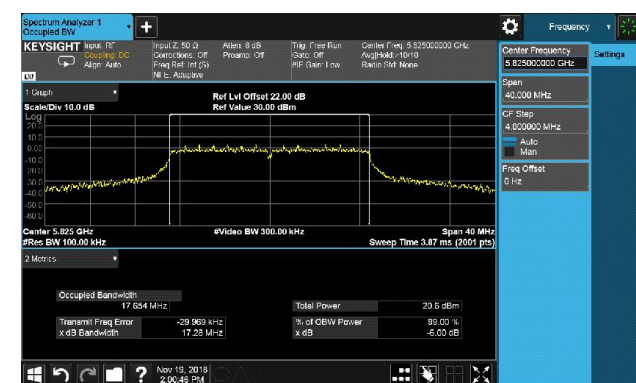



## 6.4. Output Power Measurement

### 6.4.1. Test Limit

For the band 5.15 - 5.25 GHz, the maximum conducted output power over the frequency band of operation shall not exceed 250mW provided the maximum antenna gain does not exceed 6 dBi.

For the band 5.725 - 5.85 GHz, the maximum conducted output power over the frequency band of operation shall not exceed 1 W (30dBm).

If transmitting antennas of directional gain greater than 6dBi are used, the maximum conducted output power shall be reduced by the amount in dB that the directional gain of the antenna exceeds 6dBi.

### 6.4.2. Test Procedure Used

KDB 789033 D02v02r01 - Section E) 3) b) Method PM-G

### 6.4.3. Test Setting

Average power measurements were performed only when the EUT was transmitting at its maximum power control level using a broadband power meter with a pulse sensor. The power meter implemented triggering and gating capabilities which were set up such that power measurements were recorded only during the ON time of the transmitter.

### 6.4.4. Test Setup

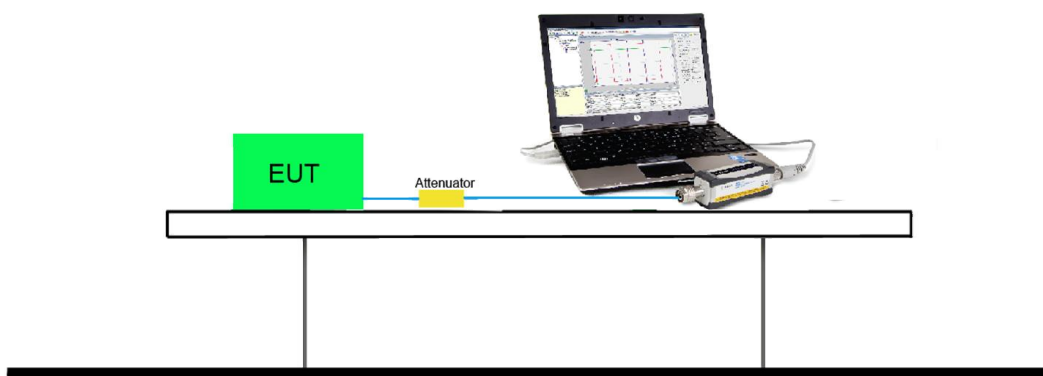

#### 6.4.5. Test Result

Power output test was verified over all data rates of each mode shown as below table, and then choose the maximum power output (grey marker) for final test of each channel.

Test Mode	Bandwidth	Channel	Frequency (MHz)	Data Rate/ MCS	Average Power (dBm)
802.11a	20	36	5180	6Mbps	14.65
				24Mbps	14.59
				54Mbps	14.53
802.11n-HT20	20	36	5180	MCS0	14.56
				MCS4	14.50
				MCS8	14.42



Product	Dual band wifi module	Temperature	24°C
Test Engineer	Jone Zhang	Relative Humidity	59%
Test Site	TR3	Test Date	2018/11/19

Test Mode	Data Rate/ MCS	Channel No.	Freq. (MHz)	Average Power (dBm)	Power Limit (dBm)	Result
11a	6Mbps	36	5180	14.65	23.98	Pass
11a	6Mbps	44	5220	14.48	23.98	Pass
11a	6Mbps	48	5240	14.26	23.98	Pass
11a	6Mbps	149	5745	14.38	30.00	Pass
11a	6Mbps	157	5785	14.89	30.00	Pass
11a	6Mbps	165	5825	15.34	30.00	Pass
11n-HT20	MCS0	36	5180	14.56	23.98	Pass
11n-HT20	MCS0	40	5220	14.36	23.98	Pass
11n-HT20	MCS0	48	5240	14.16	23.98	Pass
11n-HT20	MCS0	149	5745	14.29	30.00	Pass
11n-HT20	MCS0	157	5785	14.83	30.00	Pass
11n-HT20	MCS0	165	5825	15.31	30.00	Pass

## 6.5. Transmit Power Control

### 6.5.1. Test Limit

The U-NII device is required to have the capability to operate at least 6 dB below the mean EIRP value of 30 dBm.

### 6.5.2. Test Procedure Used

KDB 789033 D02v01- Section E)3)b) Method PM-G

### 6.5.3. Test Setting

Average power measurements were performed only when the EUT was transmitting at its maximum power control level using a broadband power meter with a pulse sensor. The power meter implemented triggering and gating capabilities which were set up such that power measurements were recorded only during the ON time of the transmitter.

### 6.5.4. Test Setup



### 6.5.5. Test Result

The device doesn't support the 5.25-5.35 GHz band and the 5.47-5.725 GHz band, so the item is not applicable.

## 6.6. Power Spectral Density Measurement

### 6.6.1. Test Limit

For the band 5.15-5.25 GHz, the maximum power spectral density shall not exceed 11 dBm in any 1 megahertz band.

For the band 5.725-5.85 GHz, the maximum power spectral density shall not exceed 30 dBm in any 500-kHz band.

If transmitting antennas of directional gain greater than 6dBi are used, the peak power spectral density shall be reduced by the amount in dB that the directional gain of the antenna exceeds 6dBi.

### 6.6.2. Test Procedure Used

KDB 789033 D02v02r01 - Section F

### 6.6.3. Test Setting

1. Analyzer was set to the center frequency of the UNII channel under investigation
2. Span was set to encompass the entire 26dB EBW of the signal.
3. RBW = 1MHz, if measurement bandwidth of Maximum PSD is specified in 500 kHz,  
RBW = 100 kHz
4. VBW = 3MHz
5. Number of sweep points  $\geq 2 \times (\text{span} / \text{RBW})$
6. Detector = power averaging (Average)
7. Sweep time = auto
8. Trigger = free run
9. Use the peak search function on the instrument to find the peak of the spectrum and record its value.
10. Add  $10 \cdot \log(1/x)$ , where  $x$  is the duty cycle, to the measured power in order to compute the average power during the actual transmission times (because the measurement represents an average over both the on and off times of the transmission). For example, add  $10 \cdot \log(1/0.25) = 6$  dB if the duty cycle is 25 percent.
11. When the measurement bandwidth of Maximum PSD is specified in 500 kHz, add a constant factor  $10 \cdot \log(500\text{kHz}/100\text{kHz}) = 6.99$  dB to the measured result.

### 6.6.4. Test Setup

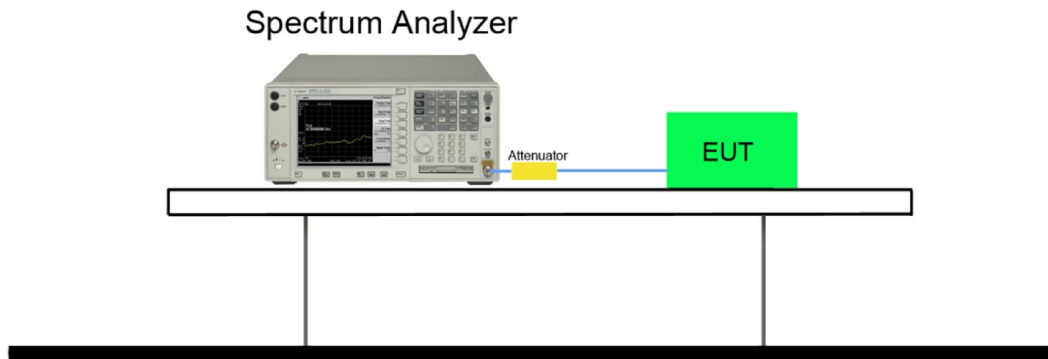

### 6.6.5. Test Result

Product	Dual band wifi module	Temperature	25°C
Test Engineer	Jone Zhang	Relative Humidity	59%
Test Site	TR3	Test Date	2018/11/19

#### For 5180-5240MHz Band:

Test Mode	Data Rate/ MCS	Channel No.	Freq. (MHz)	PSD (dBm/ MHz)	Duty Cycle (%)	Total PSD (dBm/ MHz)	PSD Limit (dBm/MHz)	Result
11a	6Mbps	36	5180	3.36	97.61	3.46	11.00	Pass
11a	6Mbps	44	5220	2.97	97.61	3.07	11.00	Pass
11a	6Mbps	48	5240	3.26	97.61	3.37	11.00	Pass
11n-HT20	MCS0	36	5180	2.98	97.48	3.09	11.00	Pass
11n-HT20	MCS0	44	5220	2.63	97.48	2.74	11.00	Pass
11n-HT20	MCS0	48	5240	2.90	97.48	3.01	11.00	Pass

Note 1: When EUT duty cycle  $\geq$  98%, the total PSD (dBm/MHz) = PSD (dBm/MHz).

Note 2: When EUT duty cycle  $<$  98%, the total PSD (dBm/MHz) = PSD (dBm/MHz) +  $10 \cdot \log(1/\text{Duty Cycle})$ .

#### For 5745-5825MHz Band:

Test Mode	Data Rate/ MCS	Channel No.	Freq. (MHz)	PSD (dBm/ 100kHz)	Duty Cycle (%)	Constant Factor	Total PSD (dBm/500 KHz)	PSD Limit (dBm/ 500kHz)	Result
11a	6Mbps	149	5745	-5.35	97.61	6.99	1.75	30.00	Pass
11a	6Mbps	157	5785	-5.61	97.61	6.99	1.49	30.00	Pass
11a	6Mbps	165	5825	-4.48	97.61	6.99	2.62	30.00	Pass
11n-HT20	MCS0	149	5745	-5.64	97.48	6.99	1.35	30.00	Pass
11n-HT20	MCS0	157	5785	-4.90	97.48	6.99	2.09	30.00	Pass
11n-HT20	MCS0	165	5825	-5.16	97.48	6.99	1.83	30.00	Pass

Note 1: When EUT duty cycle  $\geq$  98%, the total PSD (dBm/500KHz) = PSD (dBm/100KHz) + Constant Factor.

Note 2: When EUT duty cycle  $<$  98%, the total PSD (dBm/500KHz) = PSD (dBm/100KHz) + Constant Factor +  $10 \cdot \log(1/\text{Duty Cycle})$ .

### 802.11a Power Spectral Density

Channel 36 (5180MHz)



Channel 44 (5220MHz)



Channel 48 (5240MHz)



Channel 149 (5745MHz)

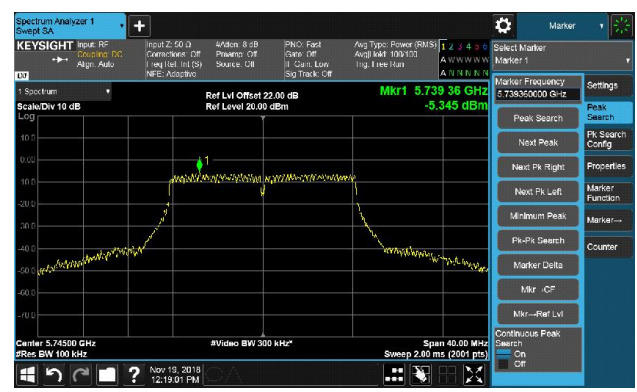

Channel 157 (5785MHz)

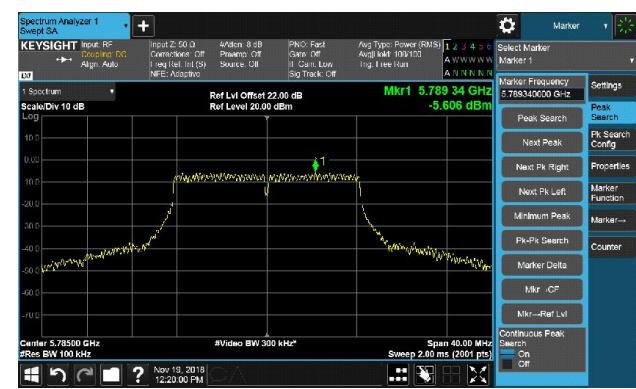

Channel 165 (5825MHz)





### 802.11n-HT20 Power Spectral Density

Channel 36 (5180MHz)



Channel 44 (5220MHz)

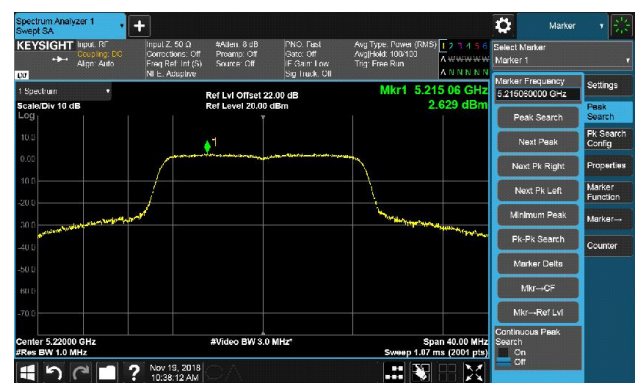

Channel 48 (5240MHz)



Channel 149 (5745MHz)

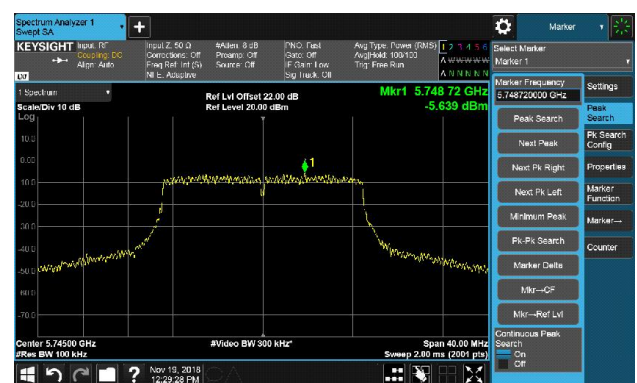

Channel 157 (5785MHz)

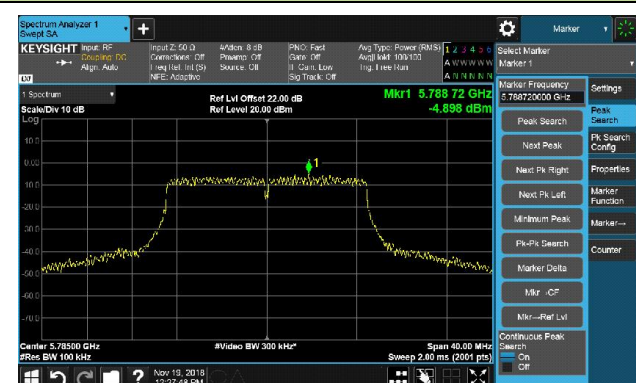

Channel 165 (5825MHz)

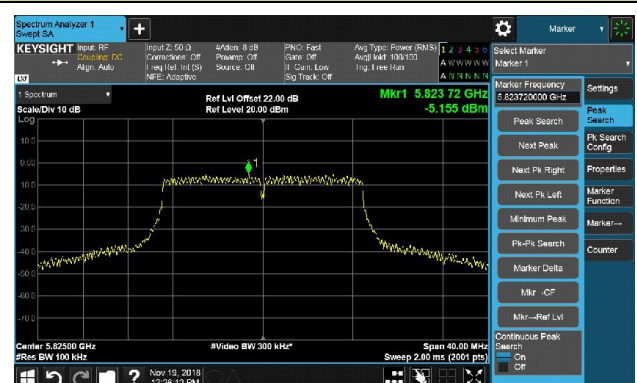

## 6.7. Frequency Stability Measurement

### 6.7.1. Test Limit

Fundamental emissions must be contained within the frequency bands specified in this section during all conditions of operation.

The transmitter center frequency tolerance shall be  $\pm 20$  ppm maximum for the 5GHz band (IEEE 802.11 specification).

### 6.7.2. Test Procedure Used

#### Frequency Stability Under Temperature Variations:

The equipment under test was connected to an external AC or DC power supply and input rated voltage. RF output was connected to a frequency counter or spectrum analyzer via feed through attenuators. The EUT was placed inside the temperature chamber. Set the spectrum analyzer RBW low enough to obtain the desired frequency resolution and measure EUT 20°C operating frequency as reference frequency. Turn EUT off and set the chamber temperature to highest. After the temperature stabilized for approximately 30 minutes recorded the frequency. Repeat step measure with 10°C decreased per stage until the lowest temperature reached.

#### Frequency Stability Under Voltage Variations:

Set chamber temperature to 20°C. Use a variable AC power supply / DC power source to power the EUT and set the voltage to rated voltage. Set the spectrum analyzer RBW low enough to obtain the desired frequency resolution and recorded the frequency.

Reduce the input voltage to specify extreme voltage variation ( $\pm 15\%$ ) and endpoint, record the maximum frequency change.

### 6.7.3. Test Setup

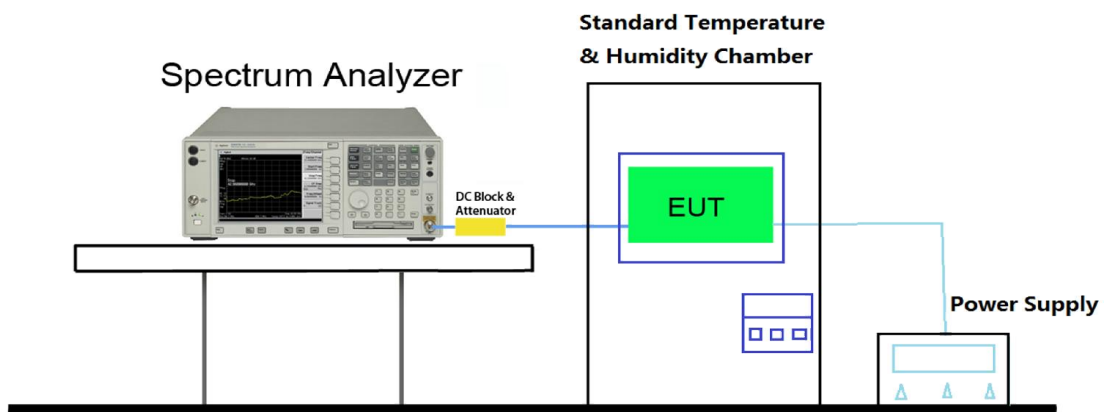

**6.7.4. Test Result**

Product	Dual band wifi module	Temperature	-10 ~ 60°C
Test Engineer	Jone Zhang	Relative Humidity	46 ~ 55%RH
Test Site	TR3	Test Time	2018/12/17
Test Mode	5180MHz (Carrier Mode)		

Voltage (%)	Power (VAC)	Temp (°C)	Frequency Tolerance (ppm)
100%	120	- 10	-7.72
		0	-15.44
		+ 10	-8.45
		+ 20 (Ref)	-6.33
		+ 30	-6.32
		+ 40	-5.40
		+ 50	-3.86
		+ 60	-8.95
115%	138	+ 20	-6.45
85%	102	+ 20	-7.32

Note 1: Frequency Tolerance (ppm) =  $\{[\text{Measured Frequency (Hz)} - \text{Declared Frequency (Hz)}] / \text{Declared Frequency (Hz)}\} * 10^6$ .

Note 2: Operating temperature range is declared by manufacturer.

## 6.8. Radiated Spurious Emission Measurement

### 6.8.1. Test Limit

All out of band emissions appearing in a restricted band as specified in Section 15.205 of the Title 47CFR must not exceed the limits shown in Table per Section 15.209.

FCC Part 15 Subpart C Paragraph 15.209		
Frequency [MHz]	Field Strength [uV/m]	Measured Distance [Meters]
0.009 - 0.490	2400/F (kHz)	300
0.490 - 1.705	24000/F (kHz)	30
1.705 - 30	30	30
30 - 88	100	3
88 - 216	150	3
216 - 960	200	3
Above 960	500	3

### 6.8.2. Test Procedure Used

ANSI C63.10 Section 6.3 (General Requirements)

ANSI C63.10 Section 6.4 (Standard test method below 30MHz)

ANSI C63.10 Section 6.5 (Standard test method above 30MHz to 1GHz)

ANSI C63.10 Section 6.6 (Standard test method above 1GHz)

### 6.8.3. Test Setting

**Table 1 - RBW as a function of frequency**

Frequency	RBW
9 ~ 150 kHz	200 ~ 300 Hz
0.15 ~ 30 MHz	9 ~ 10 kHz
30 ~ 1000 MHz	100 ~ 120 kHz

**Quasi-Peak Measurements below 1GHz**

1. Analyzer center frequency was set to the frequency of the radiated spurious emission of interest
2. Span was set greater than 1MHz
3. RBW = as specified in Table 1
4. Detector = CISPR quasi-peak
5. Sweep time = auto couple
6. Trace was allowed to stabilize

**Peak Measurements above 1GHz**

1. Analyzer center frequency was set to the frequency of the radiated spurious emission of interest
2. RBW = 1MHz
3. VBW = 3MHz
4. Detector = peak
5. Sweep time = auto couple
6. Trace mode = max hold
7. Trace was allowed to stabilize

**Average Measurements above 1GHz (Method VB)**

1. Analyzer center frequency was set to the frequency of the radiated spurious emission of interest
2. RBW = 1MHz
3. VBW; If the EUT is configured to transmit with duty cycle  $\geq 98\%$ , set VBW = 10 Hz.  
If the EUT duty cycle is  $< 98\%$ , set VBW  $\geq 1/T$ . T is the minimum transmission duration.
4. Detector = Peak
5. Sweep time = auto
6. Trace mode = max hold
7. Trace was allowed to stabilize

### 6.8.4. Test Setup

#### 9kHz ~30MHz Test Setup:

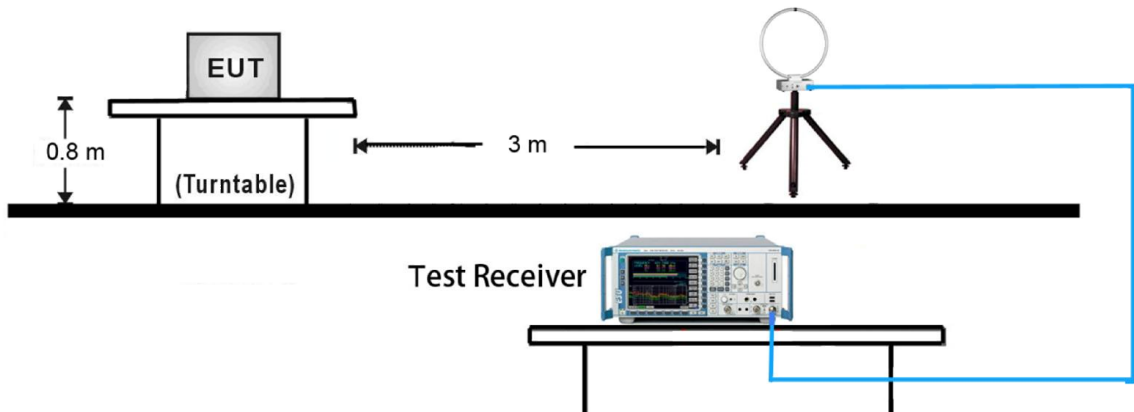

#### 30MHz ~ 1GHz Test Setup:

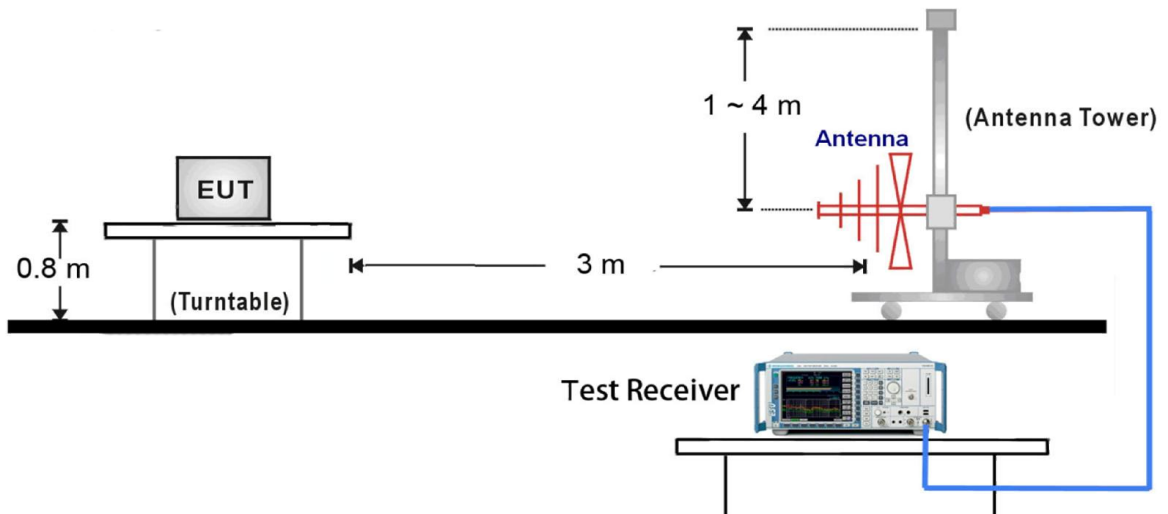

1GHz ~18GHz Test Setup:

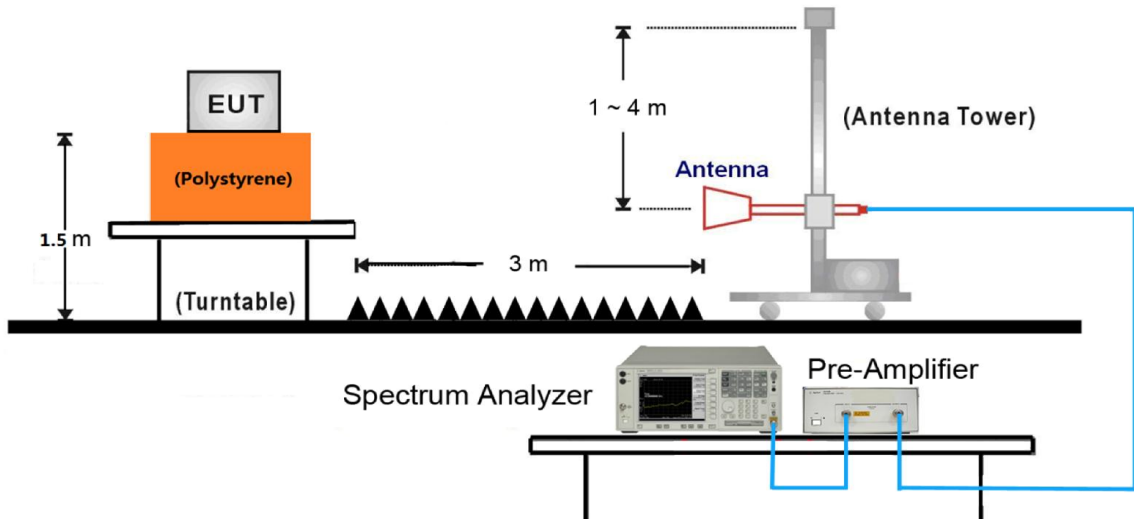

18GHz ~40GHz Test Setup:

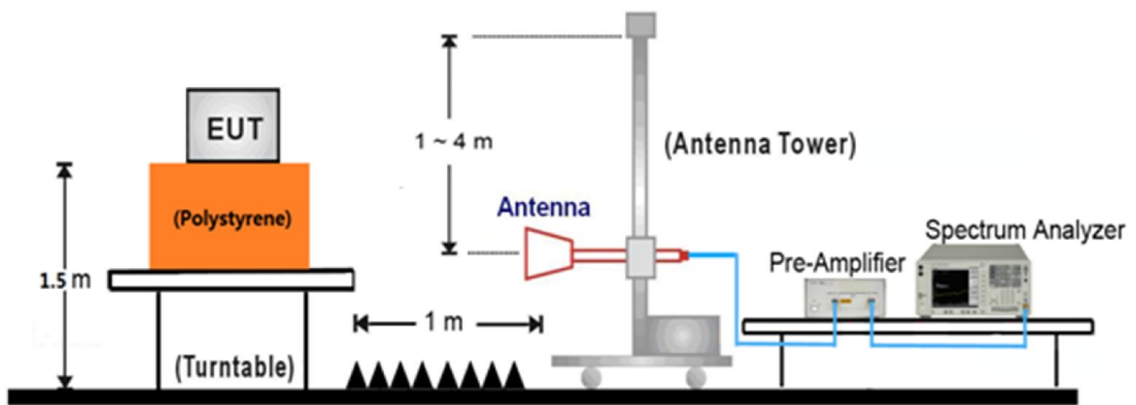

**6.8.5. Test Result**

Product	Dual band wifi module	Temperature	26°C
Test Engineer	Flag Yang	Relative Humidity	57 %
Test Site	AC1	Test Date	2018/11/16
Test Mode:	802.11a	Test Channel:	36
Remark:	1. Average measurement was not performed if peak level lower than average limit. So the margin was calculated using the average limit for emissions fall within the restricted bands. 2. Other frequency was 20dB below limit line within 1-18GHz, there is not show in the report.		

Mark	Frequency (MHz)	Reading Level (dBμV)	Factor (dB)	Measure Level (dBμV/m)	Limit (dBμV/m)	Margin (dB)	Detector	Polarization
*	9950.5	35.3	16.7	52.0	68.2	-16.2	Peak	Horizontal
*	10358.5	46.9	17.4	64.3	68.2	-3.9	Peak	Horizontal
	11897.0	34.8	17.3	52.1	74.0	-21.9	Peak	Horizontal
	15543.5	36.7	18.9	55.6	74.0	-18.4	Peak	Horizontal
	15543.5	24.7	18.9	43.6	54.0	-10.4	Average	Horizontal
*	9984.5	34.8	16.7	51.5	68.2	-16.7	Peak	Vertical
*	10358.5	43.4	17.4	60.8	68.2	-7.4	Peak	Vertical
	11956.5	34.6	17.3	51.9	74.0	-22.1	Peak	Vertical
	12449.5	33.8	17.2	51.0	74.0	-23.0	Peak	Vertical

Note 1: "\*" is not in restricted band, its limit is -27dBm/MHz. At a distance of 3 meters, the field strength limit in dBμV/m can be determined by adding a "conversion" factor of 95.2dB to the EIRP limit of -27dBm/MHz to obtain the limit for out of band spurious emissions.

Note 2: Measure Level (dBμV/m) = Reading Level (dBμV) + Factor (dB)

Factor (dB) = Cable Loss (dB) + Antenna Factor (dB/m) - Pre\_Amplifier Gain (dB)



Product	Dual band wifi module	Temperature	26°C
Test Engineer	Flag Yang	Relative Humidity	57 %
Test Site	AC1	Test Date	2018/11/16
Test Mode:	802.11a	Test Channel:	44
Remark:	<ol style="list-style-type: none"> <li>1. Average measurement was not performed if peak level lower than average limit. So the margin was calculated using the average limit for emissions fall within the restricted bands.</li> <li>2. Other frequency was 20dB below limit line within 1-18GHz, there is not show in the report.</li> </ol>		

Mark	Frequency (MHz)	Reading Level (dBμV)	Factor (dB)	Measure Level (dBμV/m)	Limit (dBμV/m)	Margin (dB)	Detector	Polarization
*	9925.0	34.4	16.6	51.0	68.2	-17.2	Peak	Horizontal
*	10435.0	46.2	17.3	63.5	68.2	-4.7	Peak	Horizontal
	11846.0	33.8	17.2	51.0	74.0	-23.0	Peak	Horizontal
	15654.0	37.4	18.9	56.3	74.0	-17.7	Peak	Horizontal
	15654.5	25.8	18.9	44.7	54.0	-9.3	Average	Horizontal
*	9738.0	35.6	15.9	51.5	68.2	-16.7	Peak	Vertical
*	10435.0	39.5	17.3	56.8	68.2	-11.4	Peak	Vertical
	12067.0	33.5	17.5	51.0	74.0	-23.0	Peak	Vertical
	15669.8	23.3	18.8	42.1	54.0	-11.9	Average	Vertical
	15671.0	36.0	18.8	54.8	74.0	-19.2	Peak	Vertical

Note 1: "\*" is not in restricted band, its limit is -27dBm/MHz. At a distance of 3 meters, the field strength limit in dBμV/m can be determined by adding a "conversion" factor of 95.2dB to the EIRP limit of -27dBm/MHz to obtain the limit for out of band spurious emissions.

Note 2: Measure Level (dBμV/m) = Reading Level (dBμV) + Factor (dB)

Factor (dB) = Cable Loss (dB) + Antenna Factor (dB/m) - Pre\_Amplifier Gain (dB)

Product	Dual band wifi module	Temperature	26°C
Test Engineer	Flag Yang	Relative Humidity	57 %
Test Site	AC1	Test Date	2018/11/16
Test Mode:	802.11a	Test Channel:	48
Remark:	<ol style="list-style-type: none"> <li>1. Average measurement was not performed if peak level lower than average limit. So the margin was calculated using the average limit for emissions fall within the restricted bands.</li> <li>2. Other frequency was 20dB below limit line within 1-18GHz, there is not show in the report.</li> </ol>		

Mark	Frequency (MHz)	Reading Level (dBμV)	Factor (dB)	Measure Level (dBμV/m)	Limit (dBμV/m)	Margin (dB)	Detector	Polarization
*	9814.5	34.1	16.4	50.5	68.2	-17.7	Peak	Horizontal
*	10486.0	43.8	17.5	61.3	68.2	-6.9	Peak	Horizontal
	11710.0	33.9	17.3	51.2	74.0	-22.8	Peak	Horizontal
	15730.5	36.9	18.9	55.8	74.0	-18.2	Peak	Horizontal
	15730.5	24.6	18.9	43.5	54.0	-10.5	Average	Horizontal
*	9848.5	34.3	16.7	51.0	68.2	-17.2	Peak	Vertical
*	10477.5	38.9	17.4	56.3	68.2	-11.9	Peak	Vertical
	11854.5	34.3	17.2	51.5	74.0	-22.5	Peak	Vertical
	15705.0	35.6	18.9	54.5	74.0	-19.5	Peak	Vertical
	15705.5	23.7	18.9	42.6	54.0	-11.4	Average	Vertical

Note 1: "\*" is not in restricted band, its limit is -27dBm/MHz. At a distance of 3 meters, the field strength limit in dBμV/m can be determined by adding a "conversion" factor of 95.2dB to the EIRP limit of -27dBm/MHz to obtain the limit for out of band spurious emissions.

Note 2: Measure Level (dBμV/m) = Reading Level (dBμV) + Factor (dB)

Factor (dB) = Cable Loss (dB) + Antenna Factor (dB/m) - Pre\_Amplifier Gain (dB)

Product	Dual band wifi module	Temperature	26°C
Test Engineer	Flag Yang	Relative Humidity	57 %
Test Site	AC1	Test Date	2018/11/16
Test Mode:	802.11a	Test Channel:	149
Remark:	1. Average measurement was not performed if peak level lower than average limit. So the margin was calculated using the average limit for emissions fall within the restricted bands. 2. Other frequency was 20dB below limit line within 1-18GHz, there is not show in the report.		

Mark	Frequency (MHz)	Reading Level (dBμV)	Factor (dB)	Measure Level (dBμV/m)	Limit (dBμV/m)	Margin (dB)	Detector	Polarization
*	9636.0	34.4	15.5	49.9	68.2	-18.3	Peak	Horizontal
*	10180.0	33.8	17.1	50.9	68.2	-17.3	Peak	Horizontal
	11489.0	37.1	17.8	54.9	74.0	-19.1	Peak	Horizontal
	11490.0	26.3	17.8	44.1	54.0	-9.9	Average	Horizontal
	12492.0	34.0	17.4	51.4	74.0	-22.6	Peak	Horizontal
*	10035.5	33.5	16.7	50.2	68.2	-18.0	Peak	Vertical
*	10307.5	33.9	17.3	51.2	68.2	-17.0	Peak	Vertical
	11795.0	34.0	17.3	51.3	74.0	-22.7	Peak	Vertical
	12390.0	33.3	17.2	50.5	74.0	-23.5	Peak	Vertical

Note 1: "\*" is not in restricted band, its limit is -27dBm/MHz. At a distance of 3 meters, the field strength limit in dBμV/m can be determined by adding a "conversion" factor of 95.2dB to the EIRP limit of -27dBm/MHz to obtain the limit for out of band spurious emissions.

Note 2: Measure Level (dBμV/m) = Reading Level (dBμV) + Factor (dB)

Factor (dB) = Cable Loss (dB) + Antenna Factor (dB/m) - Pre\_Amplifier Gain (dB)

Product	Dual band wifi module	Temperature	26°C
Test Engineer	Flag Yang	Relative Humidity	57 %
Test Site	AC1	Test Date	2018/11/16
Test Mode:	802.11a	Test Channel:	157
Remark:	1. Average measurement was not performed if peak level lower than average limit. So the margin was calculated using the average limit for emissions fall within the restricted bands. 2. Other frequency was 20dB below limit line within 1-18GHz, there is not show in the report.		

Mark	Frequency (MHz)	Reading Level (dBμV)	Factor (dB)	Measure Level (dBμV/m)	Limit (dBμV/m)	Margin (dB)	Detector	Polarization
*	9746.5	34.1	16.1	50.2	68.2	-18.0	Peak	Horizontal
*	10256.5	34.8	17.2	52.0	68.2	-16.2	Peak	Horizontal
	11571.0	26.6	17.8	44.4	54.0	-9.6	Average	Horizontal
	11574.0	39.0	17.7	56.7	74.0	-17.3	Peak	Horizontal
	12398.5	34.6	17.2	51.8	74.0	-22.2	Peak	Horizontal
*	9831.5	32.8	16.6	49.4	68.2	-18.8	Peak	Vertical
*	10299.0	32.8	17.3	50.1	68.2	-18.1	Peak	Vertical
	11557.0	33.0	17.8	50.8	74.0	-23.2	Peak	Vertical
	12390.0	33.6	17.2	50.8	74.0	-23.2	Peak	Vertical

Note 1: "\*" is not in restricted band, its limit is -27dBm/MHz. At a distance of 3 meters, the field strength limit in dBμV/m can be determined by adding a "conversion" factor of 95.2dB to the EIRP limit of -27dBm/MHz to obtain the limit for out of band spurious emissions.

Note 2: Measure Level (dBμV/m) = Reading Level (dBμV) + Factor (dB)

Factor (dB) = Cable Loss (dB) + Antenna Factor (dB/m) - Pre\_Amplifier Gain (dB)

Product	Dual band wifi module	Temperature	26°C
Test Engineer	Flag Yang	Relative Humidity	57 %
Test Site	AC1	Test Date	2018/11/16
Test Mode:	802.11a	Test Channel:	165
Remark:	1. Average measurement was not performed if peak level lower than average limit. So the margin was calculated using the average limit for emissions fall within the restricted bands. 2. Other frequency was 20dB below limit line within 1-18GHz, there is not show in the report.		

Mark	Frequency (MHz)	Reading Level (dBμV)	Factor (dB)	Measure Level (dBμV/m)	Limit (dBμV/m)	Margin (dB)	Detector	Polarization
*	9806.0	34.7	16.3	51.0	68.2	-17.2	Peak	Horizontal
*	10503.0	32.7	17.6	50.3	68.2	-17.9	Peak	Horizontal
	11642.0	39.4	17.6	57.0	74.0	-17.0	Peak	Horizontal
	11650.2	26.8	17.6	44.4	54.0	-9.6	Average	Horizontal
	12271.0	33.8	17.4	51.2	74.0	-22.8	Peak	Horizontal
*	9840.0	33.9	16.7	50.6	68.2	-17.6	Peak	Vertical
*	10384.0	32.8	17.4	50.2	68.2	-18.0	Peak	Vertical
	11616.5	32.8	17.6	50.4	74.0	-23.6	Peak	Vertical
	12347.5	32.9	17.2	50.1	74.0	-23.9	Peak	Vertical

Note 1: "\*" is not in restricted band, its limit is -27dBm/MHz. At a distance of 3 meters, the field strength limit in dBμV/m can be determined by adding a "conversion" factor of 95.2dB to the EIRP limit of -27dBm/MHz to obtain the limit for out of band spurious emissions.

Note 2: Measure Level (dBμV/m) = Reading Level (dBμV) + Factor (dB)

Factor (dB) = Cable Loss (dB) + Antenna Factor (dB/m) - Pre\_Amplifier Gain (dB)

Product	Dual band wifi module	Temperature	26°C
Test Engineer	Flag Yang	Relative Humidity	57 %
Test Site	AC1	Test Date	2018/11/16
Test Mode:	802.11n-HT20	Test Channel:	36
Remark:	1. Average measurement was not performed if peak level lower than average limit. So the margin was calculated using the average limit for emissions fall within the restricted bands. 2. Other frequency was 20dB below limit line within 1-18GHz, there is not show in the report.		

Mark	Frequency (MHz)	Reading Level (dBμV)	Factor (dB)	Measure Level (dBμV/m)	Limit (dBμV/m)	Margin (dB)	Detector	Polarization
*	9840.0	34.2	16.7	50.9	68.2	-17.3	Peak	Horizontal
*	10358.5	45.8	17.4	63.2	68.2	-5.0	Peak	Horizontal
	11149.0	33.3	17.7	51.0	74.0	-23.0	Peak	Horizontal
	12118.0	32.3	17.5	49.8	74.0	-24.2	Peak	Horizontal
*	9950.5	34.3	16.7	51.0	68.2	-17.2	Peak	Vertical
*	10358.5	41.0	17.4	58.4	68.2	-9.8	Peak	Vertical
	11225.5	33.8	17.6	51.4	74.0	-22.6	Peak	Vertical
	12560.0	33.4	17.3	50.7	74.0	-23.3	Peak	Vertical

Note 1: "\*" is not in restricted band, its limit is -27dBm/MHz. At a distance of 3 meters, the field strength limit in dBμV/m can be determined by adding a "conversion" factor of 95.2dB to the EIRP limit of -27dBm/MHz to obtain the limit for out of band spurious emissions.

Note 2: Measure Level (dBμV/m) = Reading Level (dBμV) + Factor (dB)

Factor (dB) = Cable Loss (dB) + Antenna Factor (dB/m) - Pre\_Amplifier Gain (dB)

Product	Dual band wifi module	Temperature	26°C
Test Engineer	Flag Yang	Relative Humidity	57 %
Test Site	AC1	Test Date	2018/11/16
Test Mode:	802.11n-HT20	Test Channel:	44
Remark:	1. Average measurement was not performed if peak level lower than average limit. So the margin was calculated using the average limit for emissions fall within the restricted bands. 2. Other frequency was 20dB below limit line within 1-18GHz, there is not show in the report.		

Mark	Frequency (MHz)	Reading Level (dBμV)	Factor (dB)	Measure Level (dBμV/m)	Limit (dBμV/m)	Margin (dB)	Detector	Polarization
*	9738.0	33.8	15.9	49.7	68.2	-18.5	Peak	Horizontal
*	10443.5	45.5	17.2	62.7	68.2	-5.5	Peak	Horizontal
	11880.0	32.9	17.3	50.2	74.0	-23.8	Peak	Horizontal
	15662.5	35.7	18.9	54.6	74.0	-19.4	Peak	Horizontal
	15662.8	24.0	18.9	42.9	54.0	-11.1	Average	Horizontal
*	10027.0	35.4	16.6	52.0	68.2	-16.2	Peak	Vertical
*	10426.5	43.0	17.3	60.3	68.2	-7.9	Peak	Vertical
	11123.5	32.9	17.7	50.6	74.0	-23.4	Peak	Vertical
	12670.5	32.5	17.7	50.2	74.0	-23.8	Peak	Vertical

Note 1: "\*" is not in restricted band, its limit is -27dBm/MHz. At a distance of 3 meters, the field strength limit in dBμV/m can be determined by adding a "conversion" factor of 95.2dB to the EIRP limit of -27dBm/MHz to obtain the limit for out of band spurious emissions.

Note 2: Measure Level (dBμV/m) = Reading Level (dBμV) + Factor (dB)

Factor (dB) = Cable Loss (dB) + Antenna Factor (dB/m) - Pre\_Amplifier Gain (dB)

Product	Dual band wifi module	Temperature	26°C
Test Engineer	Flag Yang	Relative Humidity	57 %
Test Site	AC1	Test Date	2018/11/16
Test Mode:	802.11n-HT20	Test Channel:	48
Remark:	1. Average measurement was not performed if peak level lower than average limit. So the margin was calculated using the average limit for emissions fall within the restricted bands. 2. Other frequency was 20dB below limit line within 1-18GHz, there is not show in the report.		

Mark	Frequency (MHz)	Reading Level (dBμV)	Factor (dB)	Measure Level (dBμV/m)	Limit (dBμV/m)	Margin (dB)	Detector	Polarization
*	9865.5	35.1	16.7	51.8	68.2	-16.4	Peak	Horizontal
*	10477.5	46.7	17.4	64.1	68.2	-4.1	Peak	Horizontal
	12067.0	34.5	17.5	52.0	74.0	-22.0	Peak	Horizontal
	15713.5	37.2	18.9	56.1	74.0	-17.9	Peak	Horizontal
	15714.3	25.5	18.9	44.4	54.0	-9.6	Average	Horizontal
*	10171.5	33.9	17.0	50.9	68.2	-17.3	Peak	Vertical
*	10486.0	41.8	17.5	59.3	68.2	-8.9	Peak	Vertical
	11803.5	32.8	17.3	50.1	74.0	-23.9	Peak	Vertical
	12670.5	33.1	17.7	50.8	74.0	-23.2	Peak	Vertical

Note 1: "\*" is not in restricted band, its limit is -27dBm/MHz. At a distance of 3 meters, the field strength limit in dBμV/m can be determined by adding a "conversion" factor of 95.2dB to the EIRP limit of -27dBm/MHz to obtain the limit for out of band spurious emissions.

Note 2: Measure Level (dBμV/m) = Reading Level (dBμV) + Factor (dB)

Factor (dB) = Cable Loss (dB) + Antenna Factor (dB/m) - Pre\_Amplifier Gain (dB)



Product	Dual band wifi module	Temperature	26°C
Test Engineer	Flag Yang	Relative Humidity	57 %
Test Site	AC1	Test Date	2018/11/16
Test Mode:	802.11n-HT20	Test Channel:	149
Remark:	<ol style="list-style-type: none"> <li>1. Average measurement was not performed if peak level lower than average limit. So the margin was calculated using the average limit for emissions fall within the restricted bands.</li> <li>2. Other frequency was 20dB below limit line within 1-18GHz, there is not show in the report.</li> </ol>		

Mark	Frequency (MHz)	Reading Level (dBμV)	Factor (dB)	Measure Level (dBμV/m)	Limit (dBμV/m)	Margin (dB)	Detector	Polarization
*	9772.0	34.5	16.2	50.7	68.2	-17.5	Peak	Horizontal
*	10384.0	34.3	17.4	51.7	68.2	-16.5	Peak	Horizontal
	11489.0	37.2	17.8	55.0	74.0	-19.0	Peak	Horizontal
	11489.9	25.9	17.8	43.7	54.0	-10.3	Average	Horizontal
	12517.5	33.6	17.3	50.9	74.0	-23.1	Peak	Horizontal
*	9865.5	33.9	16.7	50.6	68.2	-17.6	Peak	Vertical
*	10367.0	33.3	17.4	50.7	68.2	-17.5	Peak	Vertical
	11795.0	33.7	17.3	51.0	74.0	-23.0	Peak	Vertical
	12364.5	33.7	17.2	50.9	74.0	-23.1	Peak	Vertical

Note 1: "\*" is not in restricted band, its limit is -27dBm/MHz. At a distance of 3 meters, the field strength limit in dBμV/m can be determined by adding a "conversion" factor of 95.2dB to the EIRP limit of -27dBm/MHz to obtain the limit for out of band spurious emissions.

Note 2: Measure Level (dBμV/m) = Reading Level (dBμV) + Factor (dB)

Factor (dB) = Cable Loss (dB) + Antenna Factor (dB/m) - Pre\_Amplifier Gain (dB)

Product	Dual band wifi module	Temperature	26°C
Test Engineer	Flag Yang	Relative Humidity	57 %
Test Site	AC1	Test Date	2018/11/16
Test Mode:	802.11n-HT20	Test Channel:	157
Remark:	1. Average measurement was not performed if peak level lower than average limit. So the margin was calculated using the average limit for emissions fall within the restricted bands. 2. Other frequency was 20dB below limit line within 1-18GHz, there is not show in the report.		

Mark	Frequency (MHz)	Reading Level (dBμV)	Factor (dB)	Measure Level (dBμV/m)	Limit (dBμV/m)	Margin (dB)	Detector	Polarization
*	9695.5	34.5	15.5	50.0	68.2	-18.2	Peak	Horizontal
*	10171.5	33.7	17.0	50.7	68.2	-17.5	Peak	Horizontal
	11565.5	38.3	17.8	56.1	74.0	-17.9	Peak	Horizontal
	11570.8	26.5	17.8	44.3	54.0	-9.7	Average	Horizontal
	12560.0	34.0	17.3	51.3	74.0	-22.7	Peak	Horizontal
*	9899.5	33.6	16.6	50.2	68.2	-18.0	Peak	Vertical
*	10443.5	33.5	17.2	50.7	68.2	-17.5	Peak	Vertical
	11548.5	33.1	17.8	50.9	74.0	-23.1	Peak	Vertical
	12551.5	33.4	17.3	50.7	74.0	-23.3	Peak	Vertical

Note 1: "\*" is not in restricted band, its limit is -27dBm/MHz. At a distance of 3 meters, the field strength limit in dBμV/m can be determined by adding a "conversion" factor of 95.2dB to the EIRP limit of -27dBm/MHz to obtain the limit for out of band spurious emissions.

Note 2: Measure Level (dBμV/m) = Reading Level (dBμV) + Factor (dB)

Factor (dB) = Cable Loss (dB) + Antenna Factor (dB/m) - Pre\_Amplifier Gain (dB)

Product	Dual band wifi module	Temperature	26°C
Test Engineer	Flag Yang	Relative Humidity	57 %
Test Site	AC1	Test Date	2018/11/16
Test Mode:	802.11n-HT20	Test Channel:	165
Remark:	1. Average measurement was not performed if peak level lower than average limit. So the margin was calculated using the average limit for emissions fall within the restricted bands. 2. Other frequency was 20dB below limit line within 1-18GHz, there is not show in the report.		

Mark	Frequency (MHz)	Reading Level (dBμV)	Factor (dB)	Measure Level (dBμV/m)	Limit (dBμV/m)	Margin (dB)	Detector	Polarization
*	8803.0	34.7	13.3	48.0	68.2	-20.2	Peak	Horizontal
*	10307.5	34.0	17.3	51.3	68.2	-16.9	Peak	Horizontal
	11642.0	38.4	17.6	56.0	74.0	-18.0	Peak	Horizontal
	11649.6	27.4	17.6	45.0	54.0	-9.0	Average	Horizontal
	12475.0	34.2	17.3	51.5	74.0	-22.5	Peak	Horizontal
*	9678.5	34.2	15.4	49.6	68.2	-18.6	Peak	Vertical
*	10188.5	33.7	17.1	50.8	68.2	-17.4	Peak	Vertical
	11336.0	34.3	17.6	51.9	74.0	-22.1	Peak	Vertical
	11897.0	34.2	17.3	51.5	74.0	-22.5	Peak	Vertical

Note 1: "\*" is not in restricted band, its limit is -27dBm/MHz. At a distance of 3 meters, the field strength limit in dBμV/m can be determined by adding a "conversion" factor of 95.2dB to the EIRP limit of -27dBm/MHz to obtain the limit for out of band spurious emissions.

Note 2: Measure Level (dBμV/m) = Reading Level (dBμV) + Factor (dB)

Factor (dB) = Cable Loss (dB) + Antenna Factor (dB/m) - Pre\_Amplifier Gain (dB)

**The Worst Case of Radiated Emission below 1GHz:**

Site: AC1	Time: 2018/12/17 - 15:14
Limit: FCC_Part15.209_RE(3m)	Engineer: Flag Yang
Probe: VULB 9168 _20-2000MHz	Polarity: Horizontal
EUT: Dual band wifi module	Power: AC 120V/60Hz

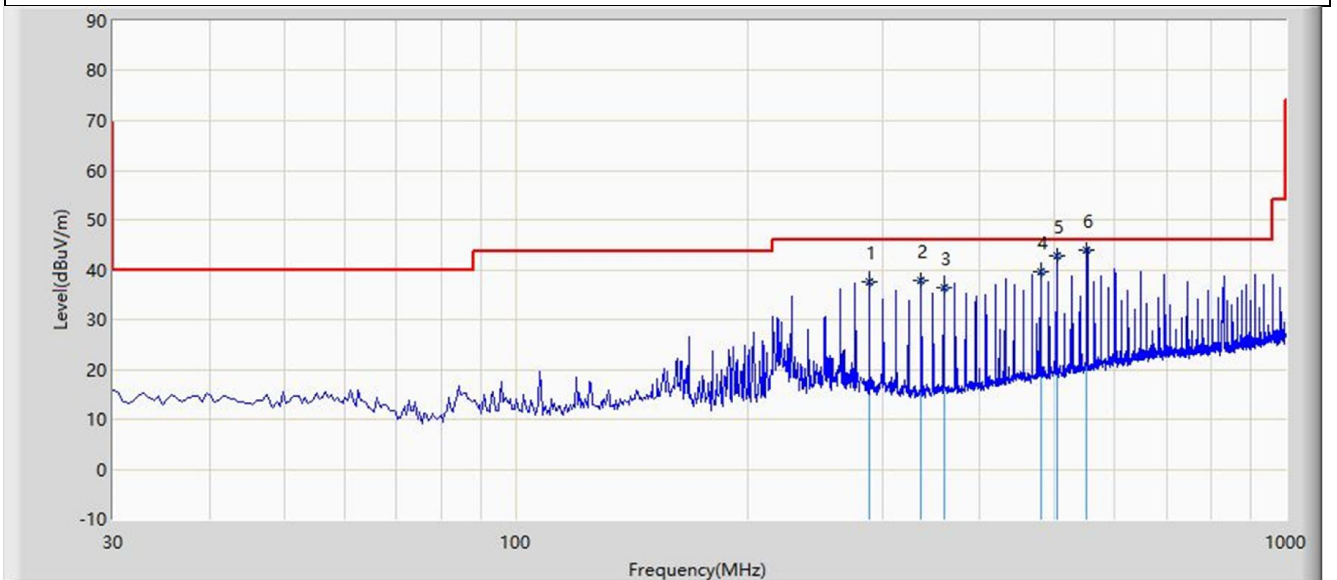
**Test Mode: Worst case**

No	Flag	Mark	Frequency (MHz)	Measure Level (dBuV/m)	Reading Level (dBuV)	Over Limit (dB)	Limit (dBuV/m)	Factor (dB)	Type
1			288.020	37.664	23.563	-8.336	46.000	14.101	QP
2			336.035	37.710	22.417	-8.290	46.000	15.293	QP
3		*	359.800	36.415	20.650	-9.585	46.000	15.765	QP
4			480.080	39.618	21.335	-6.382	46.000	18.283	QP
5			503.845	42.624	23.980	-3.376	46.000	18.644	QP
6			551.860	43.926	24.336	-2.074	46.000	19.589	QP

Note 1: Measure Level (dBuV/m) = Reading Level (dBuV) + Factor (dB)

Factor (dB) = Cable Loss (dB) + Antenna Factor (dB/m)

Note 2: The test trace is same as the ambient noise and the amplitude of the emissions are attenuated more than 20dB below the permissible (the test frequency range: 9kHz ~ 30MHz, 18GHz ~ 40GHz), therefore no data appear in the report.

Site: AC1	Time: 2018/12/17 - 15:14
Limit: FCC_Part15.209_RE(3m)	Engineer: Flag Yang
Probe: VULB 9168 _20-2000MHz	Polarity: Vertical
EUT: Dual band wifi module	Power: AC 120V/60Hz

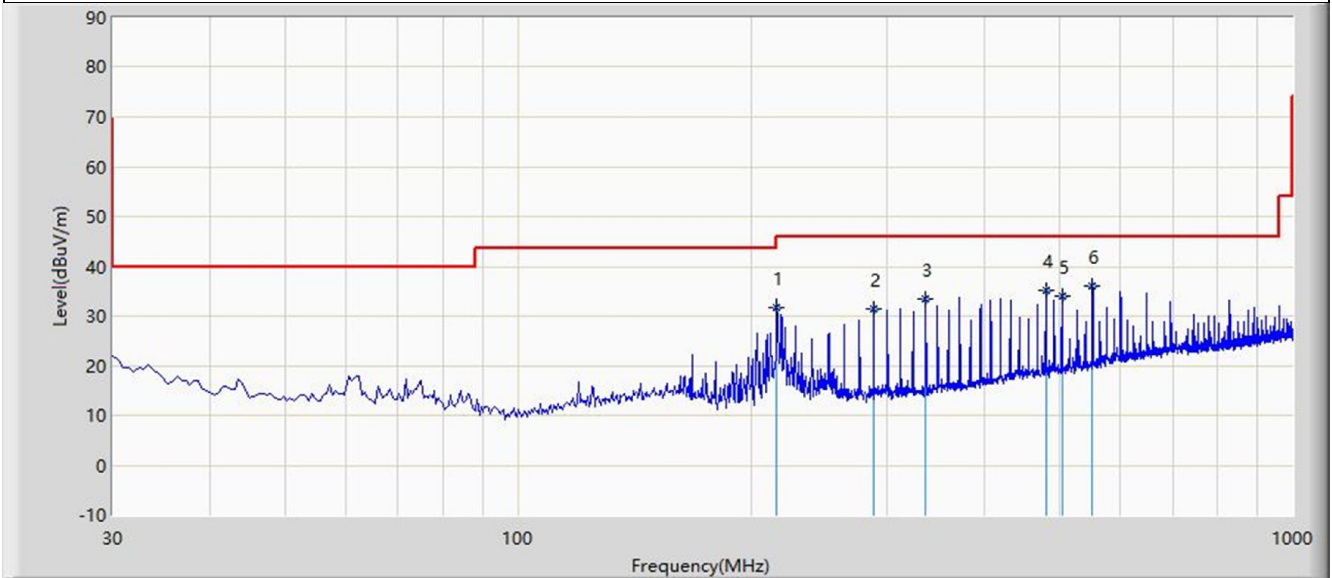
**Test Mode: Worst case**

No	Flag	Mark	Frequency (MHz)	Measure Level (dBuV/m)	Reading Level (dBuV)	Over Limit (dB)	Limit (dBuV/m)	Factor (dB)	Type
1			215.755	31.709	19.960	-11.791	43.500	11.749	QP
2			288.020	31.451	17.350	-14.549	46.000	14.101	QP
3		*	336.035	33.603	18.310	-12.397	46.000	15.293	QP
4			480.080	35.073	16.790	-10.927	46.000	18.283	QP
5			503.845	33.969	15.325	-12.031	46.000	18.644	QP
6			551.860	36.033	16.443	-9.967	46.000	19.589	QP

Note 1: Measure Level (dB $\mu$ V/m) = Reading Level (dB $\mu$ V) + Factor (dB)

Factor (dB) = Cable Loss (dB) + Antenna Factor (dB/m)

Note 2: The test trace is same as the ambient noise and the amplitude of the emissions are attenuated more than 20dB below the permissible (the test frequency range: 9kHz ~ 30MHz, 18GHz ~ 40GHz), therefore no data appear in the report.

## 6.9. Radiated Restricted Band Edge Measurement

### 6.9.1. Test Limit

#### **For 15.205 requirement:**

Radiated emissions which fall in the restricted bands, as defined in Section 15.205(a) of FCC part 15, must also comply with the radiated emission limits specified in Section 15.209(a).

Frequency (MHz)	Frequency (MHz)	Frequency (MHz)	Frequency (GHz)
0.090 - 0.110	16.42 - 16.423	399.9 - 410	4.5 - 5.15
<sup>1</sup> 0.495 - 0.505	16.69475 - 16.69525	608 - 614	5.35 - 5.46
2.1735 - 2.1905	16.80425 - 16.80475	960 - 1240	7.25 - 7.75
4.125 - 4.128	25.5 - 25.67	1300 - 1427	8.025 - 8.5
4.17725 - 4.17775	37.5 - 38.25	1435 - 1626.5	9.0 - 9.2
4.20725 - 4.20775	73 - 74.6	1645.5 - 1646.5	9.3 - 9.5
6.215 - 6.218	74.8 - 75.2	1660 - 1710	10.6 - 12.7
6.26775 - 6.26825	108 - 121.94	1718.8 - 1722.2	13.25 - 13.4
6.31175 - 6.31225	123 - 138	2200 - 2300	14.47 - 14.5
8.291 - 8.294	149.9 - 150.05	2310 - 2390	15.35 - 16.2
8.362 - 8.366	156.52475 - 156.525	2483.5 - 2500	17.7 - 21.4
8.37625 - 8.38675	156.7 - 156.9	2690 - 2900	22.01 - 23.12
8.41425 - 8.41475	162.0125 - 167.17	3260 - 3267	23.6 - 24.0
12.29 - 12.293	167.72 - 173.2	3332 - 3339	31.2 - 31.8
12.51975 - 12.52025	240 - 285	3345.8 - 3358	36.43 - 36.5
12.57675 - 12.57725	322 - 335.4	3600 - 4400	( <sup>2</sup> )
13.36 - 13.41	--	--	--

#### **For 15.407(b) requirement:**

For transmitters operating in the 5.15-5.25 GHz band: All emissions outside of the 5.15-5.35 GHz band shall not exceed an e.i.r.p. of -27 dBm/MHz.

For transmitters operating in the 5.725-5.85 GHz band: All emissions shall be limited to a level of -27 dBm/MHz at 75 MHz or more above or below the band edge increasing linearly to 10 dBm/MHz at 25 MHz above or below the band edge, and from 25 MHz above or below the band edge increasing linearly to a level of 15.6 dBm/MHz at 5 MHz above or below the band edge, and from 5 MHz above or below the band edge increasing linearly to a level of 27 dBm/MHz at the band edge.

Refer to KDB 789033 D02v02r01 G)2)c), as specified in § 15.407(b), emissions above 1000 MHz that are outside of the restricted bands are subject to a maximum emission limit of -27 dBm/MHz (or -17 dBm/MHz as specified in § 15.407(b)(4)). However, an out-of-band emission that complies with both the peak and average limits of § 15.209 is not required to satisfy the -27 dBm/MHz or -17 dBm/MHz maximum emission limit.

All out of band emissions appearing in a restricted band as specified in Section 15.205 of the Title 47CFR must not exceed the limits shown in Table per Section 15.209.

FCC Part 15 Subpart C Paragraph 15.209		
Frequency [MHz]	Field Strength [uV/m]	Measured Distance [Meters]
0.009 - 0.490	2400/F (kHz)	300
0.490 - 1.705	24000/F (kHz)	30
1.705 - 30	30	30
30 - 88	100	3
88 - 216	150	3
216 - 960	200	3
Above 960	500	3

**6.9.2. Test Procedure Used**

ANSI C63.10 Section 6.3 (General Requirements)

ANSI C63.10 Section 6.6 (Standard test method above 1GHz)

**6.9.3. Test Setting**

**Peak Measurements above 1GHz**

1. Analyzer center frequency was set to the frequency of the radiated spurious emission of interest
2. RBW = 1MHz
3. VBW = 3MHz
4. Detector = peak
5. Sweep time = auto couple
6. Trace mode = max hold
7. Trace was allowed to stabilize

### Average Measurements above 1GHz (Method VB)

1. Analyzer center frequency was set to the frequency of the radiated spurious emission of interest
2. RBW = 1MHz
3. VBW If the EUT is configured to transmit with duty cycle  $\geq 98\%$ , set  $VBW \leq RBW/100$  (i.e., 10 kHz) but not less than 10 Hz. If the EUT duty cycle is  $< 98\%$ , set  $VBW \geq 1/T$ .
4. Detector = Peak
5. Sweep time = auto
6. Allow max hold to run for at least 50 traces if the transmitted signal is continuous or has at least 98% duty cycle. For lower duty cycles, increase the minimum number of traces by a factor of  $1/x$ , where  $x$  is the duty cycle.

#### 6.9.4. Test Setup

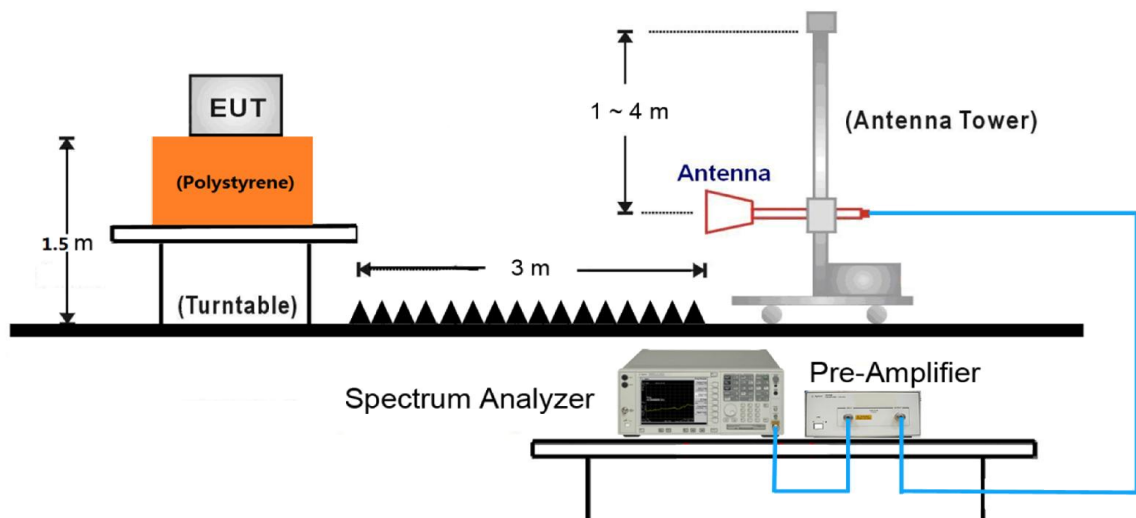



### 6.9.5. Test Result

Site: AC1	Time: 2018/11/17 - 07:44
Limit: FCC_Part15.209_RE(3m)	Engineer: Flag Yang
Probe: BBHA9120D_1-18GHz	Polarity: Horizontal
EUT: Dual band wifi module	Power: 120V/60Hz
Test Mode: Transmit by 802.11a at channel 5180MHz	

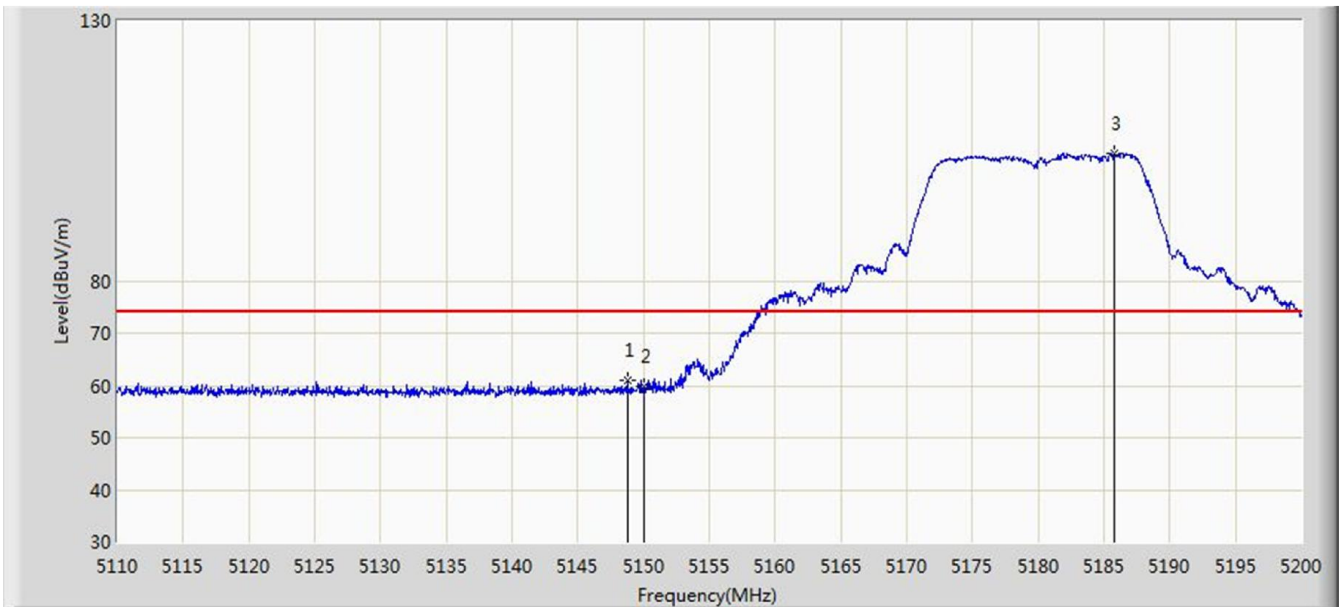

No	Flag	Mark	Frequency (MHz)	Measure Level (dBuV/m)	Reading Level (dBuV)	Over Limit (dB)	Limit (dBuV/m)	Factor (dB)	Type
1			5148.745	61.016	54.456	-12.984	74.000	6.560	PK
2			5150.000	59.849	53.287	-14.151	74.000	6.562	PK
3		*	5185.735	104.515	98.109	N/A	N/A	6.406	PK

Note: Measure Level (dB $\mu$ V/m) = Reading Level (dB $\mu$ V) + Factor (dB)

Factor (dB) = Cable Loss (dB) + Antenna Factor (dB/m).

Site: AC1	Time: 2018/11/17 - 07:52
Limit: FCC_Part15.209_RE(3m)	Engineer: Flag Yang
Probe: BBHA9120D_1-18GHz	Polarity: Horizontal
EUT: Dual band wifi module	Power: 120V/60Hz
Test Mode: Transmit by 802.11a at channel 5180MHz	

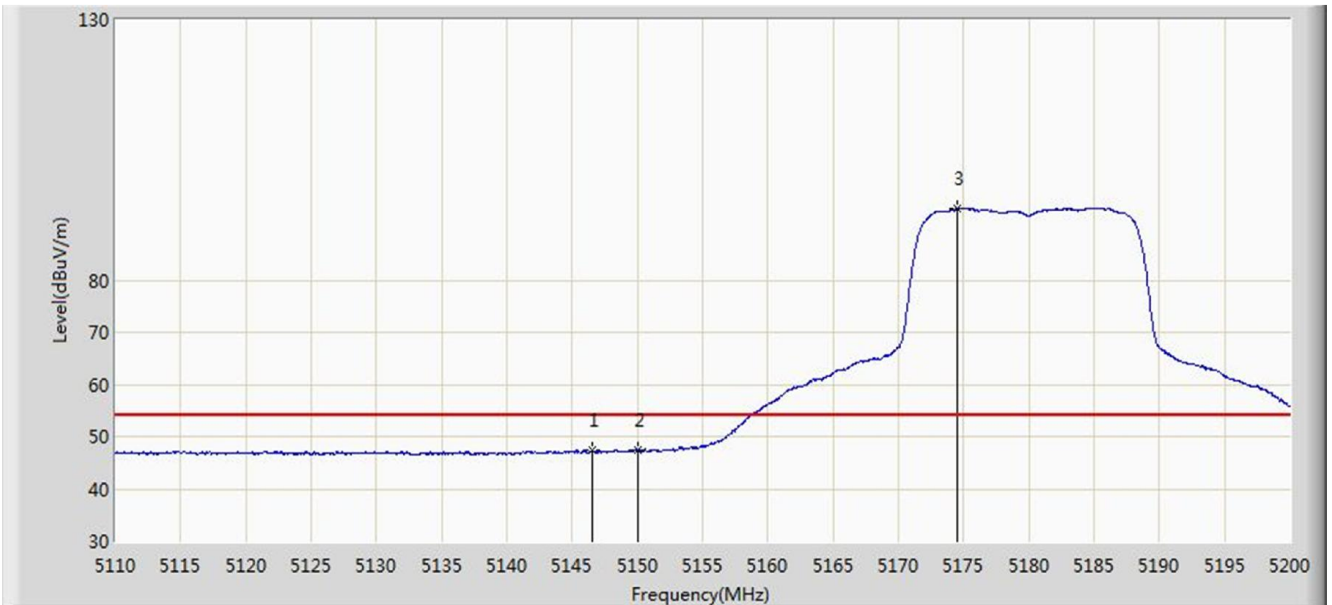

No	Flag	Mark	Frequency (MHz)	Measure Level (dBuV/m)	Reading Level (dBuV)	Over Limit (dB)	Limit (dBuV/m)	Factor (dB)	Type
1			5146.540	47.494	40.927	-6.506	54.000	6.567	AV
2			5150.000	47.383	40.821	-6.617	54.000	6.562	AV
3		*	5174.530	93.896	87.408	N/A	N/A	6.487	AV

Note: Measure Level (dB $\mu$ V/m) = Reading Level (dB $\mu$ V) + Factor (dB)

Factor (dB) = Cable Loss (dB) + Antenna Factor (dB/m).

Site: AC1	Time: 2018/11/17 - 07:54
Limit: FCC_Part15.209_RE(3m)	Engineer: Flag Yang
Probe: BBHA9120D_1-18GHz	Polarity: Vertical
EUT: Dual band wifi module	Power: 120V/60Hz
Test Mode: Transmit by 802.11a at channel 5180MHz	

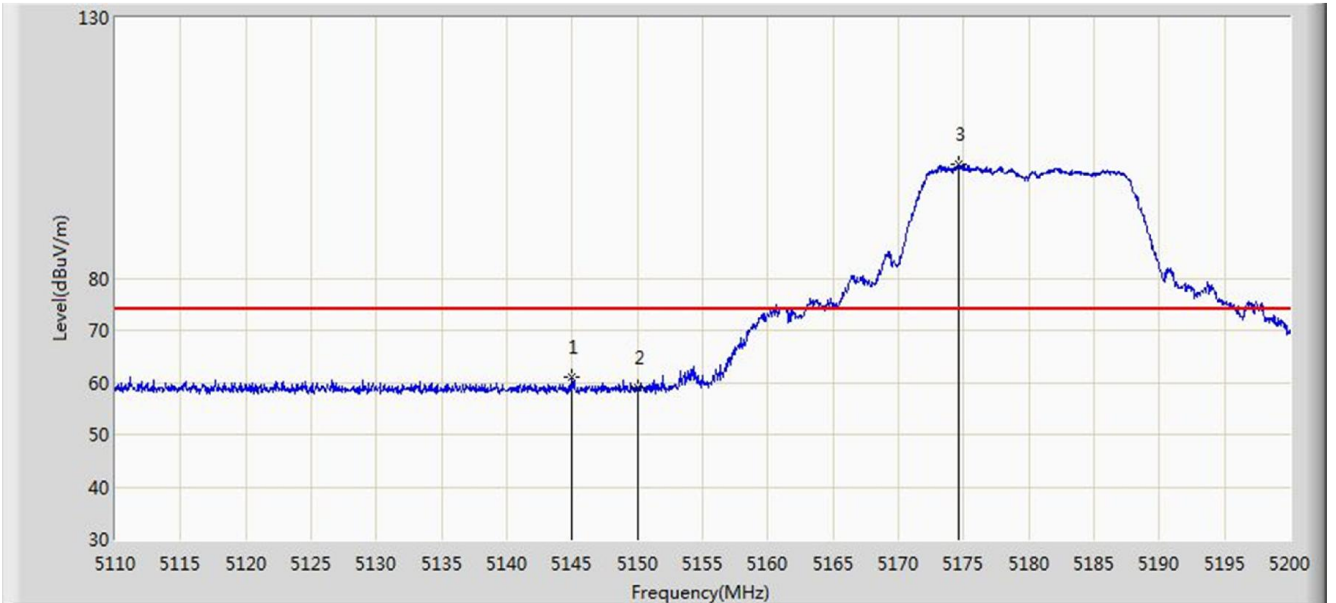

No	Flag	Mark	Frequency (MHz)	Measure Level (dBuV/m)	Reading Level (dBuV)	Over Limit (dB)	Limit (dBuV/m)	Factor (dB)	Type
1			5144.920	61.049	54.472	-12.951	74.000	6.577	PK
2			5150.000	59.023	52.461	-14.977	74.000	6.562	PK
3		*	5174.575	101.826	95.339	N/A	N/A	6.487	PK

Note: Measure Level (dB $\mu$ V/m) = Reading Level (dB $\mu$ V) + Factor (dB)

Factor (dB) = Cable Loss (dB) + Antenna Factor (dB/m).

Site: AC1	Time: 2018/11/17 - 07:57
Limit: FCC_Part15.209_RE(3m)	Engineer: Flag Yang
Probe: BBHA9120D_1-18GHz	Polarity: Vertical
EUT: Dual band wifi module	Power: 120V/60Hz
Test Mode: Transmit by 802.11a at channel 5180MHz	

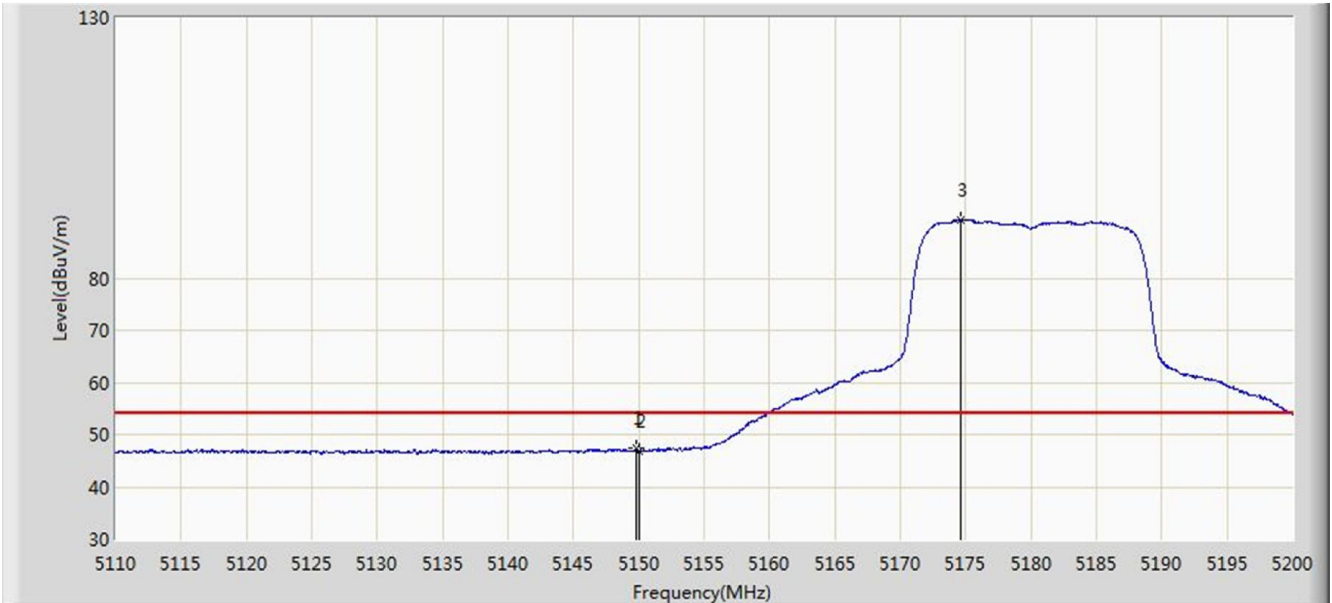

No	Flag	Mark	Frequency (MHz)	Measure Level (dBuV/m)	Reading Level (dBuV)	Over Limit (dB)	Limit (dBuV/m)	Factor (dB)	Type
1			5149.825	47.329	40.767	-6.671	54.000	6.561	AV
2			5150.000	46.929	40.367	-7.071	54.000	6.562	AV
3		*	5174.575	91.289	84.802	N/A	N/A	6.487	AV

Note: Measure Level (dBuV/m) = Reading Level (dBuV) + Factor (dB)

Factor (dB) = Cable Loss (dB) + Antenna Factor (dB/m).

Site: AC1	Time: 2018/11/17 - 08:31
Limit: FCC_Part15.407_RE(3m)_Bandedge	Engineer: Flag Yang
Probe: BBHA9120D_1-18GHz	Polarity: Horizontal
EUT: Dual band wifi module	Power: 120V/60Hz
Test Mode: Transmit by 802.11a at channel 5745MHz	

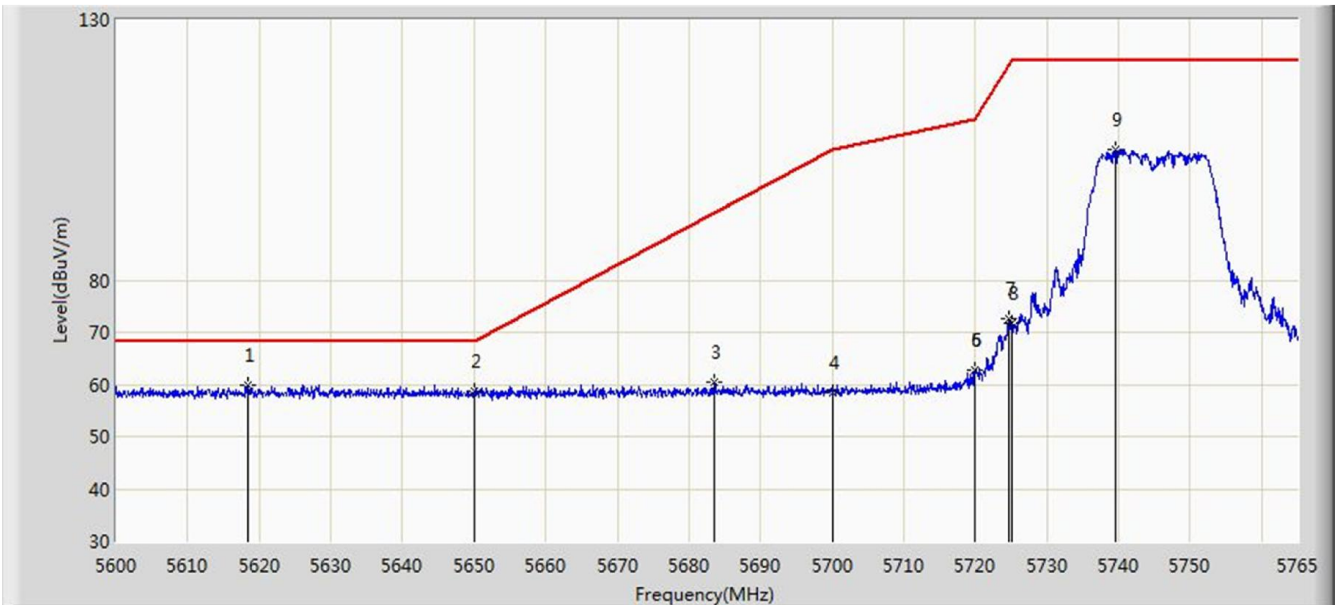

No	Flag	Mark	Frequency (MHz)	Measure Level (dBuV/m)	Reading Level (dBuV)	Over Limit (dB)	Limit (dBuV/m)	Factor (dB)	Type
1		*	5618.315	59.887	52.885	-8.313	68.200	7.002	PK
2			5650.000	58.723	51.718	-9.477	68.200	7.005	PK
3			5683.490	60.399	53.317	-32.619	93.019	7.082	PK
4			5700.000	58.294	51.129	-46.906	105.200	7.165	PK
5			5719.955	62.804	55.505	-47.983	110.787	7.299	PK
6			5720.000	62.727	55.428	-48.073	110.800	7.299	PK
7			5724.740	72.642	65.315	-48.966	121.607	7.327	PK
8			5725.000	71.814	64.486	-50.386	122.200	7.328	PK
9			5739.590	104.973	97.583	N/A	N/A	7.390	PK

Note: Measure Level (dB $\mu$ V/m) = Reading Level (dB $\mu$ V) + Factor (dB)

Factor (dB) = Cable Loss (dB) + Antenna Factor (dB/m).

Site: AC1	Time: 2018/11/17 - 08:37
Limit: FCC_Part15.407_RE(3m)_Bandedge	Engineer: Flag Yang
Probe: BBHA9120D_1-18GHz	Polarity: Vertical
EUT: Dual band wifi module	Power: 120V/60Hz
Test Mode: Transmit by 802.11a at channel 5745MHz	

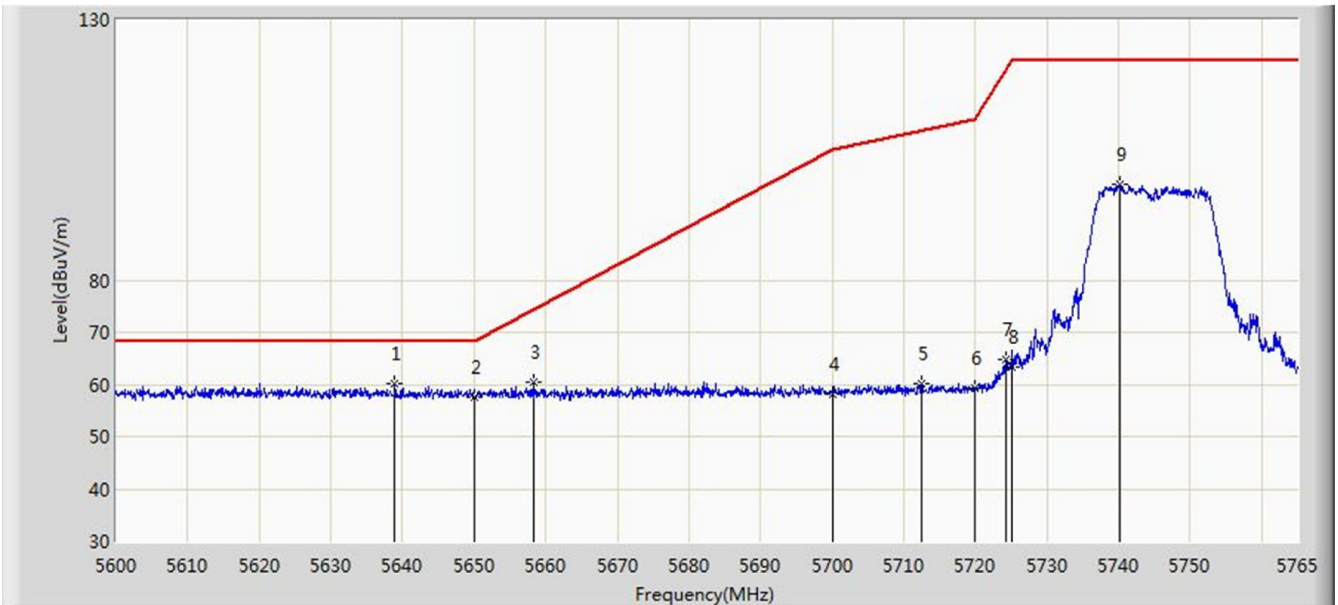

No	Flag	Mark	Frequency (MHz)	Measure Level (dBuV/m)	Reading Level (dBuV)	Over Limit (dB)	Limit (dBuV/m)	Factor (dB)	Type
1		*	5638.940	60.178	53.189	-8.022	68.200	6.989	PK
2			5650.000	57.550	50.545	-10.650	68.200	7.005	PK
3			5658.245	60.460	53.432	-13.863	74.324	7.028	PK
4			5700.000	58.205	51.040	-46.995	105.200	7.165	PK
5			5712.530	60.155	52.898	-48.556	108.711	7.257	PK
6			5720.000	59.255	51.956	-51.545	110.800	7.299	PK
7			5724.328	64.731	57.407	-55.937	120.668	7.324	PK
8			5725.000	63.390	56.062	-58.810	122.200	7.328	PK
9			5740.250	98.329	90.936	N/A	N/A	7.393	PK

Note: Measure Level (dB $\mu$ V/m) = Reading Level (dB $\mu$ V) + Factor (dB)

Factor (dB) = Cable Loss (dB) + Antenna Factor (dB/m).

Site: AC1	Time: 2018/11/17 - 08:38
Limit: FCC_Part15.407_RE(3m)_Bandedge	Engineer: Flag Yang
Probe: BBHA9120D_1-18GHz	Polarity: Horizontal
EUT: Dual band wifi module	Power: 120V/60Hz
Test Mode: Transmit by 802.11a at channel 5825MHz	

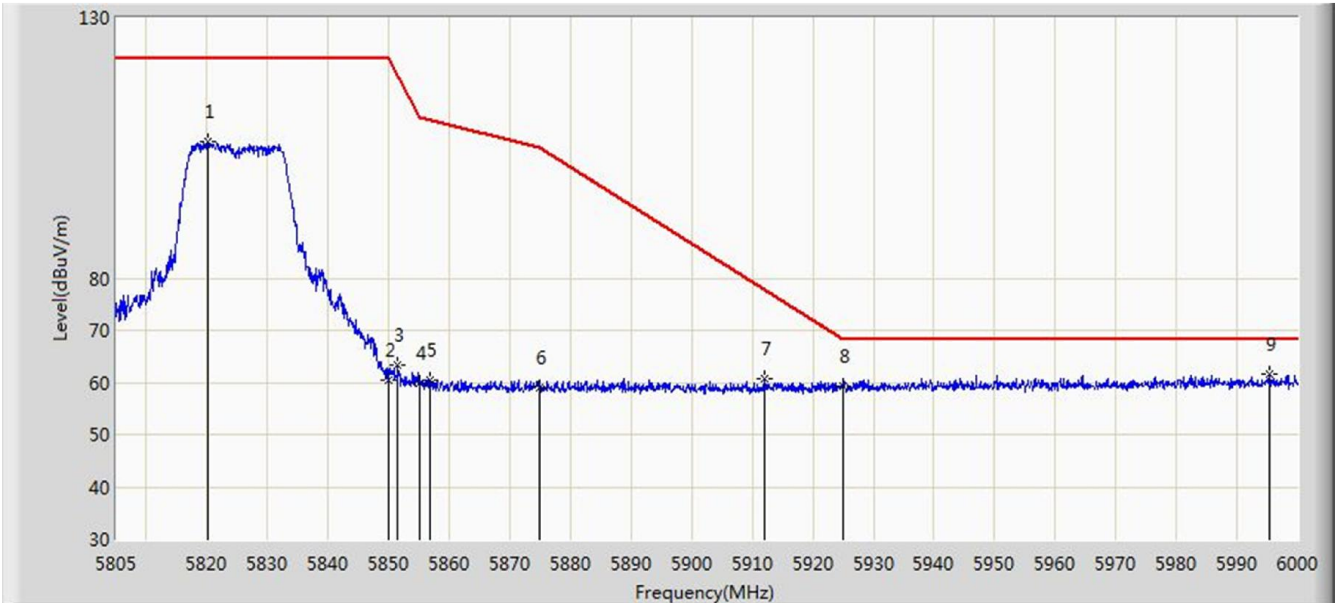

No	Flag	Mark	Frequency (MHz)	Measure Level (dBuV/m)	Reading Level (dBuV)	Over Limit (dB)	Limit (dBuV/m)	Factor (dB)	Type
1			5820.210	106.340	98.704	N/A	N/A	7.637	PK
2			5850.000	60.519	52.746	-61.681	122.200	7.774	PK
3			5851.410	63.296	55.522	-55.688	118.984	7.774	PK
4			5855.000	59.824	52.048	-50.976	110.800	7.775	PK
5			5856.870	60.526	52.749	-49.750	110.276	7.777	PK
6			5875.000	58.991	51.173	-46.209	105.200	7.818	PK
7			5912.055	60.814	53.002	-16.936	77.749	7.811	PK
8			5925.000	59.420	51.601	-8.780	68.200	7.819	PK
9		*	5995.320	61.693	53.736	-6.507	68.200	7.957	PK

Note: Measure Level (dB $\mu$ V/m) = Reading Level (dB $\mu$ V) + Factor (dB)

Factor (dB) = Cable Loss (dB) + Antenna Factor (dB/m).



Site: AC1	Time: 2018/11/17 - 08:39
Limit: FCC_Part15.407_RE(3m)_Bandedge	Engineer: Flag Yang
Probe: BBHA9120D_1-18GHz	Polarity: Vertical
EUT: Dual band wifi module	Power: 120V/60Hz
Test Mode: Transmit by 802.11a at channel 5825MHz	

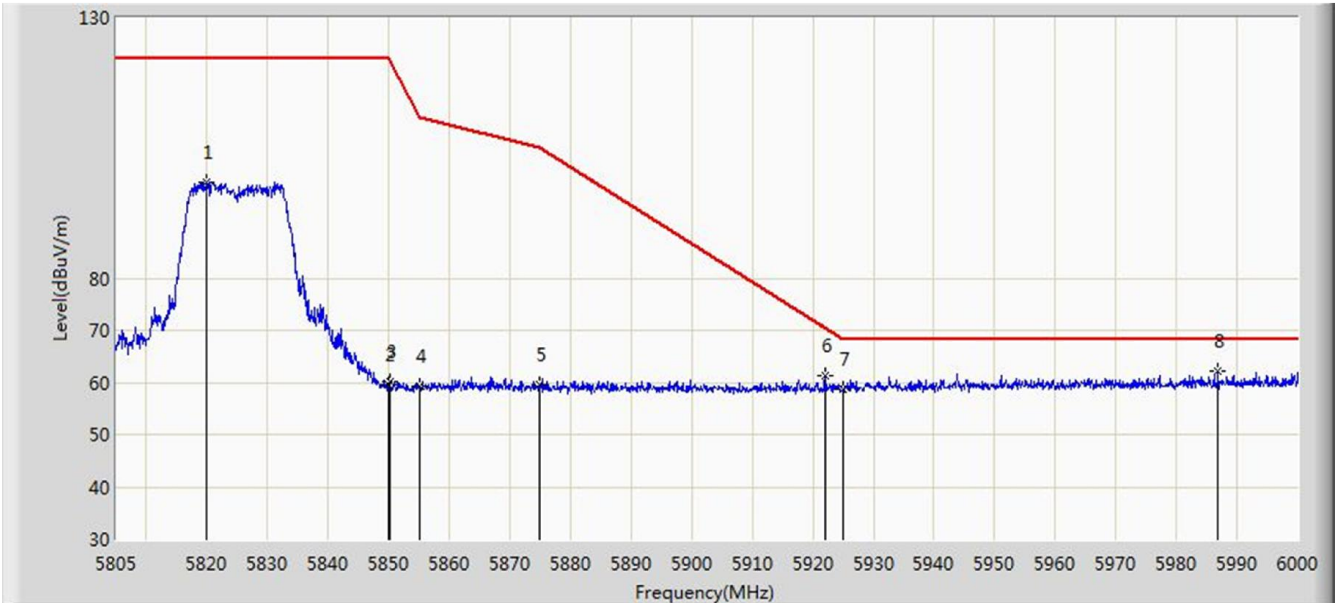

No	Flag	Mark	Frequency (MHz)	Measure Level (dBuV/m)	Reading Level (dBuV)	Over Limit (dB)	Limit (dBuV/m)	Factor (dB)	Type
1			5819.917	98.497	90.862	N/A	N/A	7.635	PK
2			5850.000	59.505	51.732	-62.695	122.200	7.774	PK
3			5850.143	60.229	52.455	-61.645	121.874	7.774	PK
4			5855.000	59.154	51.378	-51.646	110.800	7.775	PK
5			5875.000	59.447	51.629	-45.753	105.200	7.818	PK
6			5922.000	61.175	53.358	-9.236	70.411	7.817	PK
7			5925.000	58.765	50.946	-9.435	68.200	7.819	PK
8		*	5986.837	62.257	54.339	-5.943	68.200	7.918	PK

Note: Measure Level (dBμV/m) = Reading Level (dBμV) + Factor (dB)

Factor (dB) = Cable Loss (dB) + Antenna Factor (dB/m).



Site: AC1	Time: 2018/11/18 - 10:53
Limit: FCC_Part15.209_RE(3m)	Engineer: Flag Yang
Probe: BBHA9120D_1-18GHz	Polarity: Horizontal
EUT: Dual band wifi module	Power: 120V/60Hz
Test Mode: Transmit by 802.11n-HT20 at channel 5180MHz	

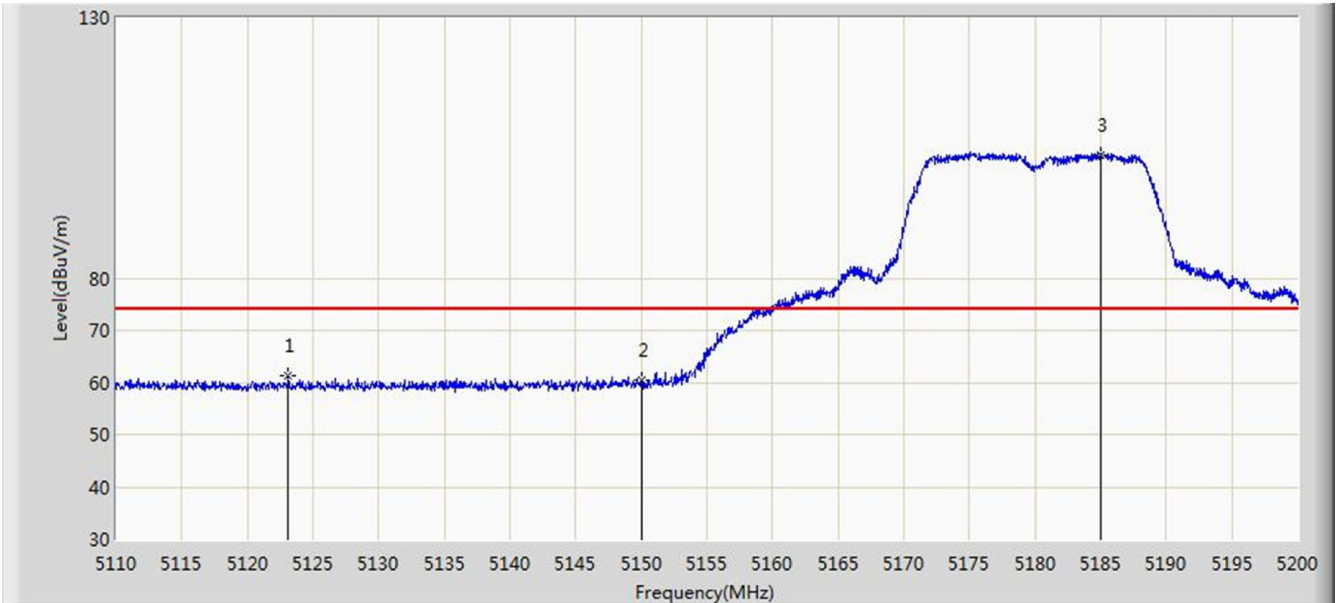

No	Flag	Mark	Frequency (MHz)	Measure Level (dBuV/m)	Reading Level (dBuV)	Over Limit (dB)	Limit (dBuV/m)	Factor (dB)	Type
1			5123.095	61.269	54.620	-12.731	74.000	6.649	PK
2			5150.000	60.315	53.753	-13.685	74.000	6.562	PK
3		*	5184.970	103.740	97.329	N/A	N/A	6.411	PK

Note: Measure Level (dB $\mu$ V/m) = Reading Level (dB $\mu$ V) + Factor (dB)

Factor (dB) = Cable Loss (dB) + Antenna Factor (dB/m).

Site: AC1	Time: 2018/11/18 - 11:07
Limit: FCC_Part15.209_RE(3m)	Engineer: Flag Yang
Probe: BBHA9120D_1-18GHz	Polarity: Horizontal
EUT: Dual band wifi module	Power: 120V/60Hz
Test Mode: Transmit by 802.11n-HT20 at channel 5180MHz	

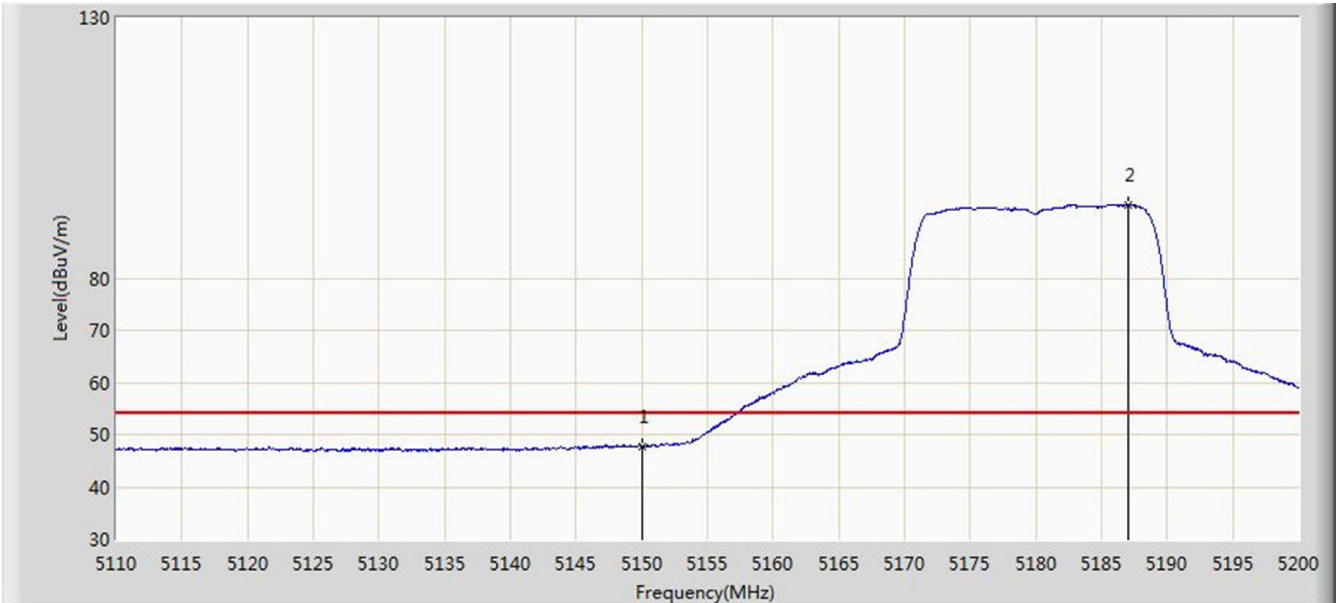

No	Flag	Mark	Frequency (MHz)	Measure Level (dBuV/m)	Reading Level (dBuV)	Over Limit (dB)	Limit (dBuV/m)	Factor (dB)	Type
1			5150.000	47.599	41.037	-6.401	54.000	6.562	AV
2		*	5187.040	94.102	87.703	N/A	N/A	6.399	AV

Note: Measure Level (dB $\mu$ V/m) = Reading Level (dB $\mu$ V) + Factor (dB)

Factor (dB) = Cable Loss (dB) + Antenna Factor (dB/m).

Site: AC1	Time: 2018/11/18 - 11:10
Limit: FCC_Part15.209_RE(3m)	Engineer: Flag Yang
Probe: BBHA9120D_1-18GHz	Polarity: Vertical
EUT: Dual band wifi module	Power: 120V/60Hz
Test Mode: Transmit by 802.11n-HT20 at channel 5180MHz	

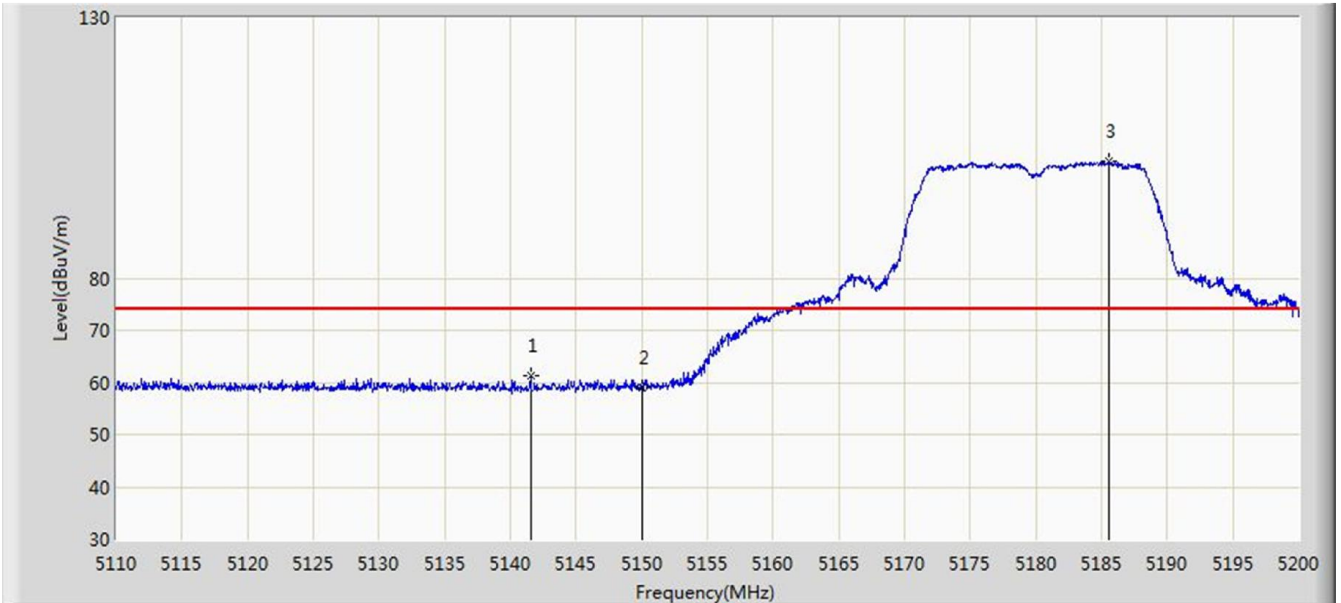

No	Flag	Mark	Frequency (MHz)	Measure Level (dBuV/m)	Reading Level (dBuV)	Over Limit (dB)	Limit (dBuV/m)	Factor (dB)	Type
1			5141.545	61.344	54.748	-12.656	74.000	6.596	PK
2			5150.000	58.944	52.382	-15.056	74.000	6.562	PK
3		*	5185.510	102.412	96.004	N/A	N/A	6.407	PK

Note: Measure Level (dB $\mu$ V/m) = Reading Level (dB $\mu$ V) + Factor (dB)

Factor (dB) = Cable Loss (dB) + Antenna Factor (dB/m).

Site: AC1	Time: 2018/11/18 - 11:13
Limit: FCC_Part15.209_RE(3m)	Engineer: Flag Yang
Probe: BBHA9120D_1-18GHz	Polarity: Vertical
EUT: Dual band wifi module	Power: 120V/60Hz
Test Mode: Transmit by 802.11n-HT20 at channel 5180MHz	

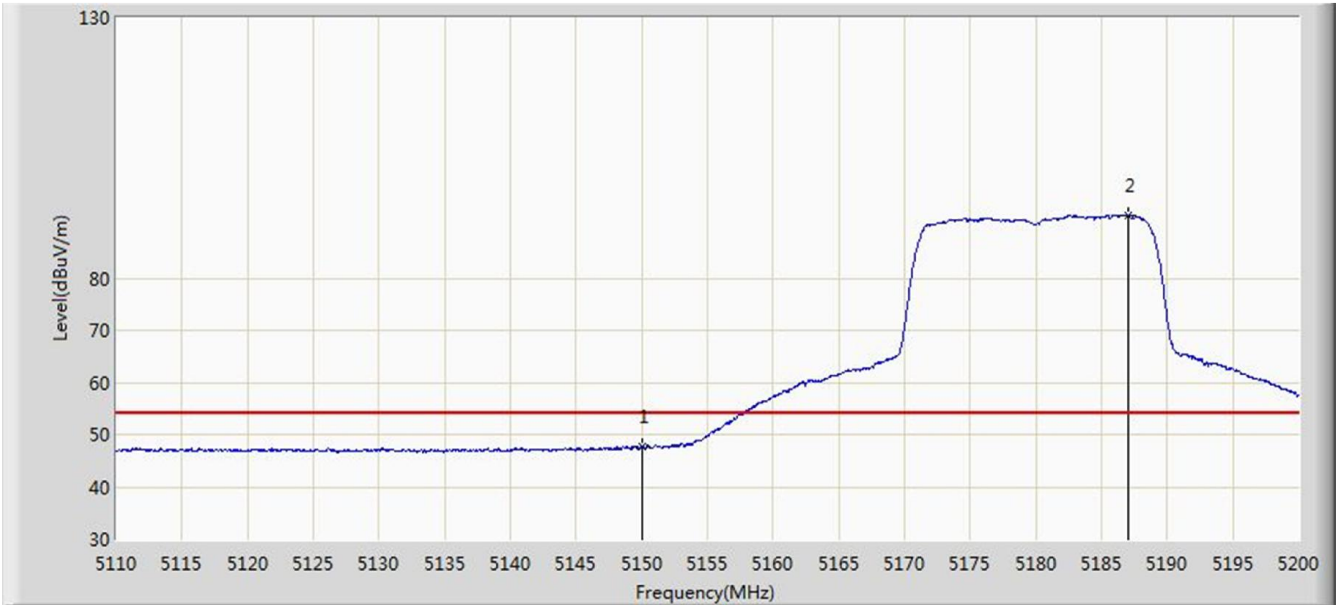

No	Flag	Mark	Frequency (MHz)	Measure Level (dBuV/m)	Reading Level (dBuV)	Over Limit (dB)	Limit (dBuV/m)	Factor (dB)	Type
1			5150.000	47.572	41.010	-6.428	54.000	6.562	AV
2		*	5187.085	92.123	85.725	N/A	N/A	6.399	AV

Note: Measure Level (dBμV/m) = Reading Level (dBμV) + Factor (dB)

Factor (dB) = Cable Loss (dB) + Antenna Factor (dB/m).

Site: AC1	Time: 2018/11/18 - 11:36
Limit: FCC_Part15.407_RE(3m)_Bandedge	Engineer: Flag Yang
Probe: BBHA9120D_1-18GHz	Polarity: Horizontal
EUT: Dual band wifi module	Power: 120V/60Hz
Test Mode: Transmit by 802.11n-HT20 at channel 5745MHz	

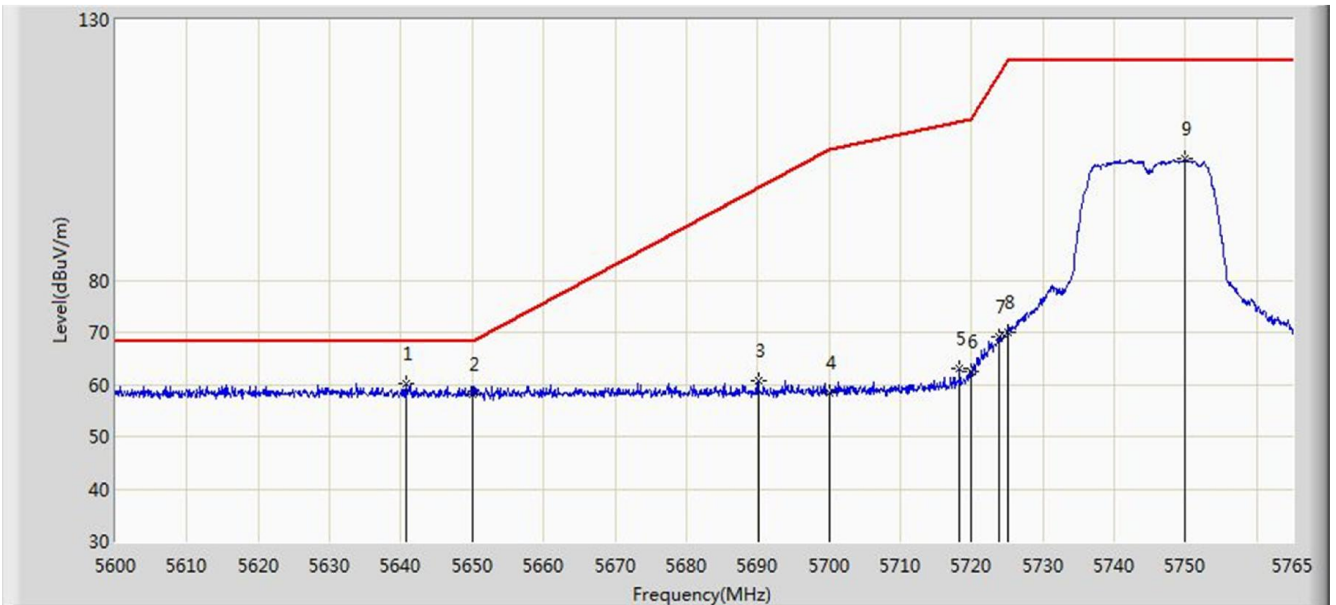

No	Flag	Mark	Frequency (MHz)	Measure Level (dBuV/m)	Reading Level (dBuV)	Over Limit (dB)	Limit (dBuV/m)	Factor (dB)	Type
1		*	5640.755	60.280	53.295	-7.920	68.200	6.986	PK
2			5650.000	58.111	51.106	-10.089	68.200	7.005	PK
3			5690.090	60.623	53.518	-37.270	97.892	7.105	PK
4			5700.000	58.322	51.157	-46.878	105.200	7.165	PK
5			5718.305	62.950	55.660	-47.376	110.326	7.289	PK
6			5720.000	62.343	55.044	-48.457	110.800	7.299	PK
7			5723.915	69.074	61.752	-50.653	119.727	7.322	PK
8			5725.000	70.123	62.795	-52.077	122.200	7.328	PK
9			5749.820	103.235	95.827	N/A	N/A	7.408	PK

Note: Measure Level (dB $\mu$ V/m) = Reading Level (dB $\mu$ V) + Factor (dB)

Factor (dB) = Cable Loss (dB) + Antenna Factor (dB/m).

Site: AC1	Time: 2018/11/18 - 11:39
Limit: FCC_Part15.407_RE(3m)_Bandedge	Engineer: Flag Yang
Probe: BBHA9120D_1-18GHz	Polarity: Vertical
EUT: Dual band wifi module	Power: 120V/60Hz
Test Mode: Transmit by 802.11n-HT20 at channel 5745MHz	

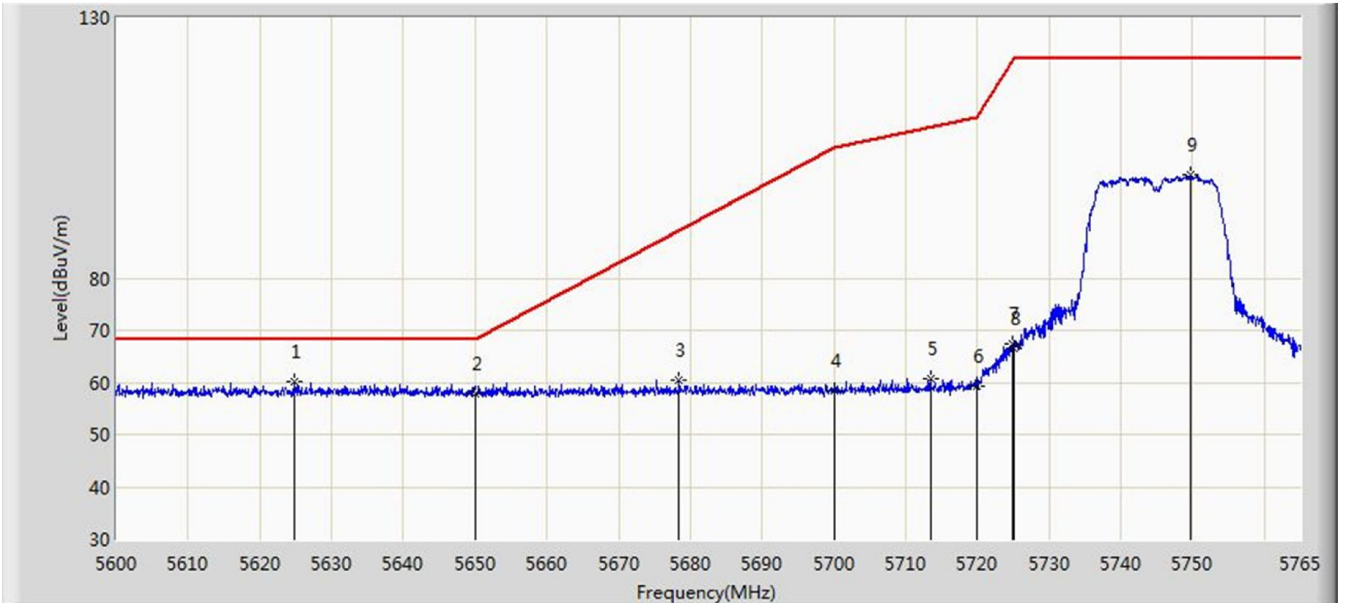

No	Flag	Mark	Frequency (MHz)	Measure Level (dBuV/m)	Reading Level (dBuV)	Over Limit (dB)	Limit (dBuV/m)	Factor (dB)	Type
1		*	5624.915	60.005	52.992	-8.195	68.200	7.013	PK
2			5650.000	57.951	50.946	-10.249	68.200	7.005	PK
3			5678.458	60.378	53.311	-28.921	89.299	7.066	PK
4			5700.000	58.544	51.379	-46.656	105.200	7.165	PK
5			5713.437	60.705	53.443	-48.259	108.965	7.262	PK
6			5720.000	59.315	52.016	-51.485	110.800	7.299	PK
7			5724.905	67.331	60.004	-54.652	121.983	7.327	PK
8			5725.000	66.662	59.334	-55.538	122.200	7.328	PK
9			5749.655	99.786	92.378	N/A	N/A	7.408	PK

Note: Measure Level (dBuV/m) = Reading Level (dBuV) + Factor (dB)

Factor (dB) = Cable Loss (dB) + Antenna Factor (dB/m).

Site: AC1	Time: 2018/11/18 - 11:41
Limit: FCC_Part15.407_RE(3m)_Bandedge	Engineer: Flag Yang
Probe: BBHA9120D_1-18GHz	Polarity: Horizontal
EUT: Dual band wifi module	Power: 120V/60Hz
Test Mode: Transmit by 802.11n-HT20 at channel 5825MHz	

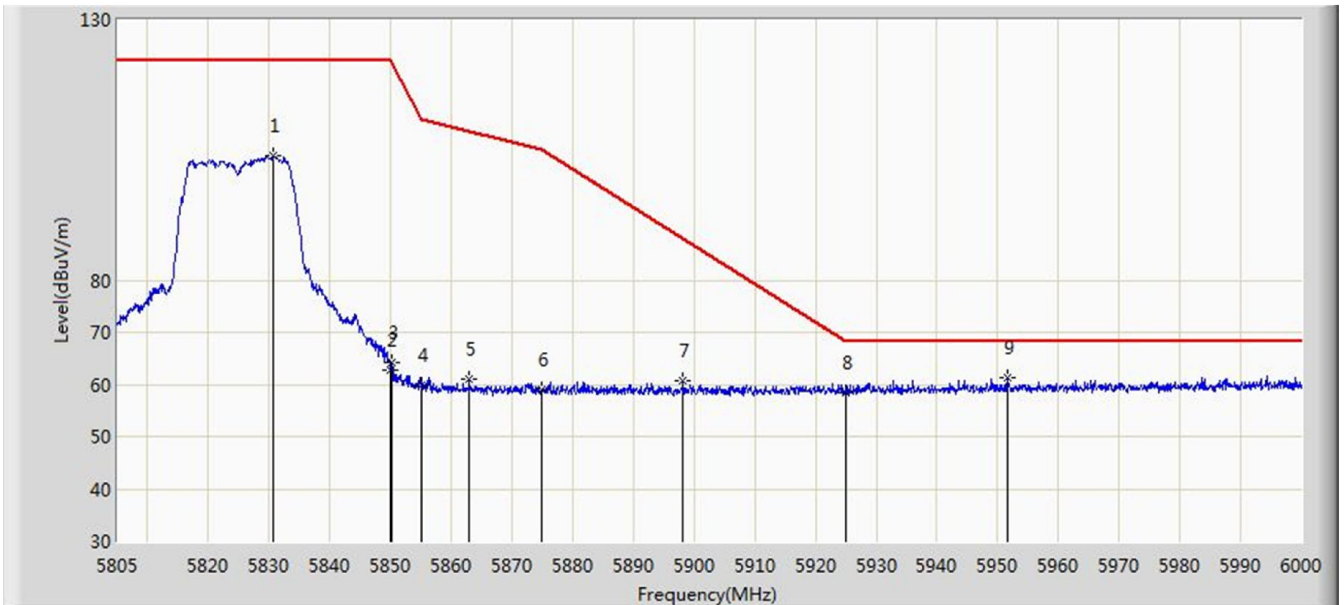

No	Flag	Mark	Frequency (MHz)	Measure Level (dBuV/m)	Reading Level (dBuV)	Over Limit (dB)	Limit (dBuV/m)	Factor (dB)	Type
1			5830.740	103.869	96.181	N/A	N/A	7.687	PK
2			5850.000	62.847	55.074	-59.353	122.200	7.774	PK
3			5850.240	64.259	56.485	-57.394	121.653	7.774	PK
4			5855.000	59.985	52.209	-50.815	110.800	7.775	PK
5			5862.915	60.944	53.161	-47.638	108.582	7.783	PK
6			5875.000	59.033	51.215	-46.167	105.200	7.818	PK
7			5898.210	60.645	52.811	-27.341	87.986	7.834	PK
8			5925.000	58.353	50.534	-9.847	68.200	7.819	PK
9		*	5951.542	61.170	53.326	-7.030	68.200	7.844	PK

Note: Measure Level (dB $\mu$ V/m) = Reading Level (dB $\mu$ V) + Factor (dB)

Factor (dB) = Cable Loss (dB) + Antenna Factor (dB/m).



Site: AC1	Time: 2018/11/18 - 11:46
Limit: FCC_Part15.407_RE(3m)_Bandedge	Engineer: Flag Yang
Probe: BBHA9120D_1-18GHz	Polarity: Vertical
EUT: Dual band wifi module	Power: 120V/60Hz
Test Mode: Transmit by 802.11n-HT20 at channel 5825MHz	

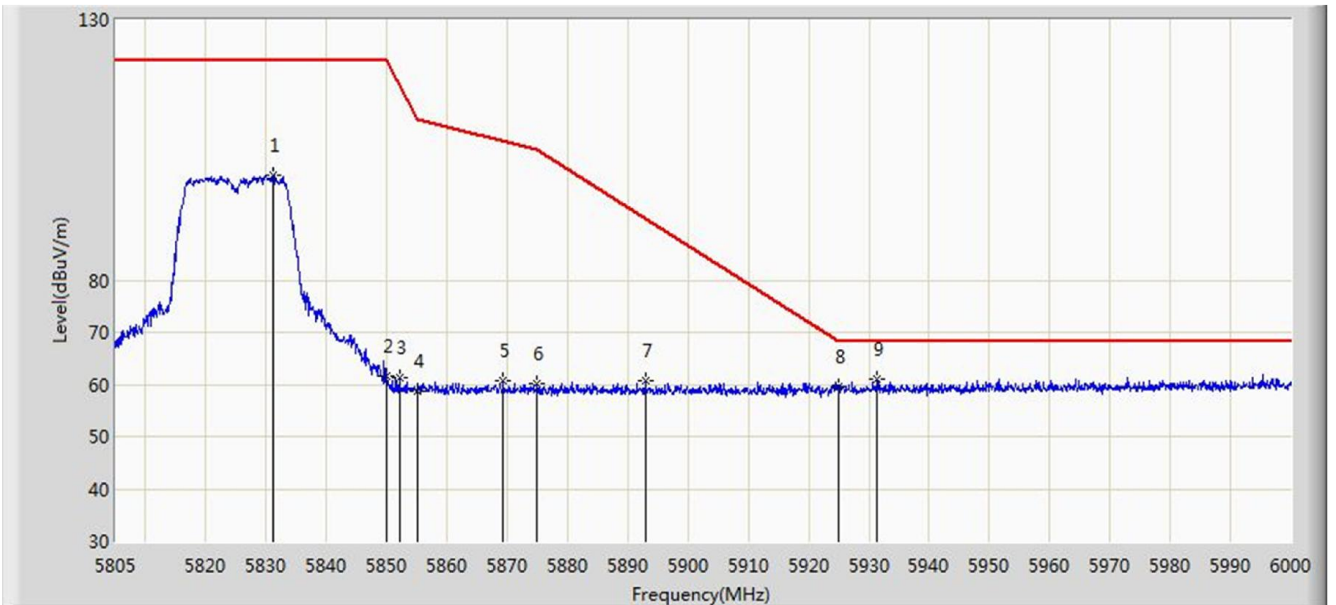

No	Flag	Mark	Frequency (MHz)	Measure Level (dBuV/m)	Reading Level (dBuV)	Over Limit (dB)	Limit (dBuV/m)	Factor (dB)	Type
1			5831.130	100.130	92.440	N/A	N/A	7.690	PK
2			5850.000	61.585	53.812	-60.615	122.200	7.774	PK
3			5852.092	61.394	53.619	-56.036	117.429	7.775	PK
4			5855.000	58.738	50.962	-52.062	110.800	7.775	PK
5			5869.350	60.627	52.825	-46.154	106.780	7.801	PK
6			5875.000	60.125	52.307	-45.075	105.200	7.818	PK
7			5892.945	60.846	53.012	-31.039	91.885	7.834	PK
8			5925.000	59.570	51.751	-8.630	68.200	7.819	PK
9		*	5931.360	61.089	53.265	-7.111	68.200	7.824	PK

Note: Measure Level (dBuV/m) = Reading Level (dBuV) + Factor (dB)

Factor (dB) = Cable Loss (dB) + Antenna Factor (dB/m).



## 6.10. AC Conducted Emissions Measurement

### 6.10.1. Test Limit

FCC Part 15.207 Limits		
Frequency (MHz)	QP (dB $\mu$ V)	AV (dB $\mu$ V)
0.15 - 0.50	66 - 56	56 - 46
0.50 - 5.0	56	46
5.0 - 30	60	50

Note 1: The lower limit shall apply at the transition frequencies.

Note 2: The limit decreases linearly with the logarithm of the frequency in the range 0.15MHz to 0.5MHz.

### 6.10.2. Test Procedure

The EUT was setup according to ANSI C63.10, 2013 for compliance to RSS-Gen Issue 5 requirements. The EUT was placed on a platform of nominal size, 1 m by 1.5 m, raised 80 cm above the conducting ground plane. The vertical conducting plane was located 40 cm to the rear of the EUT. All other surfaces of EUT were at least 80 cm from any other grounded conducting surface. The EUT and simulators are connected to the main power through a line impedance stabilization network (LISN). The LISN provides a 50 ohm /50uH coupling impedance for the measuring equipment. The peripheral devices are also connected to the main power through a LISN. (Please refer to the block diagram of the test setup and photographs) Each current-carrying conductor of the EUT power cord, except the ground (safety) conductor, was individually connected through a LISN to the input power source.

The excess length of the power cord between the EUT and the LISN receptacle were folded back and forth at the center of the lead to form a bundle not exceeding 40 cm in length.

Conducted emissions were investigated over the frequency range from 0.15MHz to 30MHz using a receiver bandwidth of 9 kHz.

### 6.10.3. Test Setup

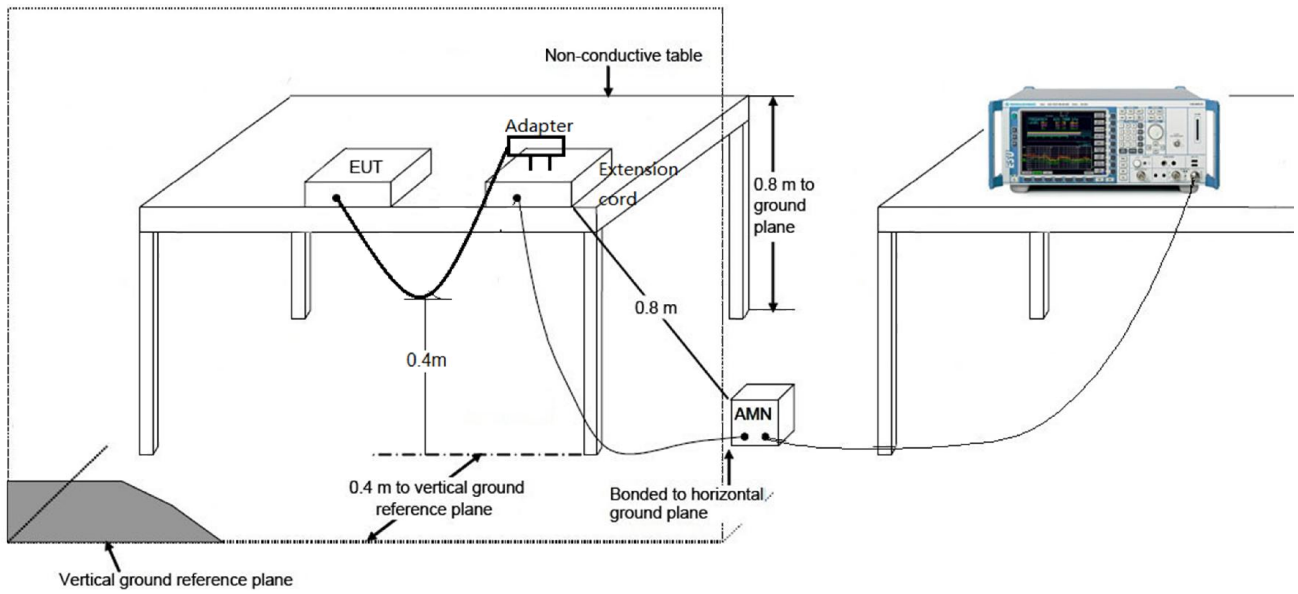

### 6.10.4. Test Result

Site: SR2	Time: 2018/11/20 - 14:59
Limit: FCC_Part15.207_CE_AC Power_ClassB	Engineer: Cloud Guo
Probe: ENV216_101683_Filter On	Polarity: Line
EUT: Dual band wifi module	Power: AC 120V/60Hz
Test Mode 1	

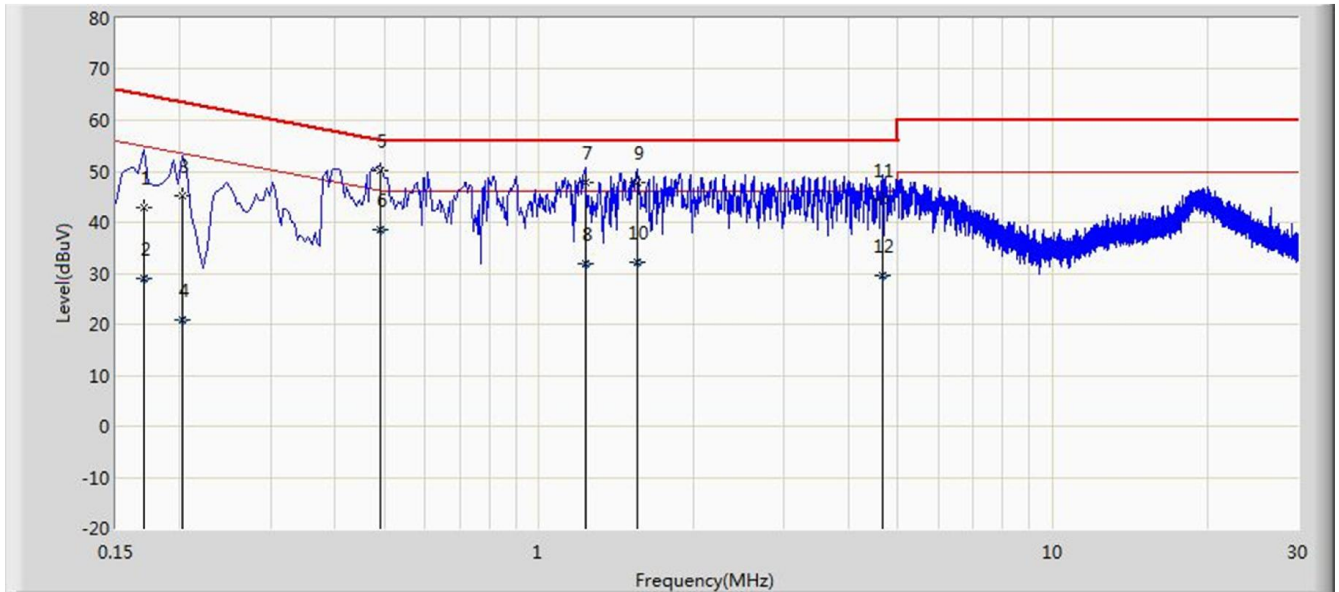

No	Flag	Mark	Frequency (MHz)	Measure Level (dBuV)	Reading Level (dBuV)	Over Limit (dB)	Limit (dBuV)	Factor (dB)	Type
1			0.170	42.980	32.903	-21.980	64.960	10.078	QP
2			0.170	28.998	18.921	-25.962	54.960	10.078	AV
3			0.202	45.188	35.195	-18.340	63.528	9.993	QP
4		*	0.202	20.865	10.872	-32.663	53.528	9.993	AV
5			0.490	50.254	40.096	-5.914	56.168	10.158	QP
6			0.490	38.666	28.508	-7.502	46.168	10.158	AV
7			1.230	47.818	37.918	-8.182	56.000	9.900	QP
8			1.230	32.025	22.125	-13.975	46.000	9.900	AV
9			1.550	47.921	38.034	-8.079	56.000	9.887	QP
10			1.550	32.147	22.260	-13.853	46.000	9.887	AV
11			4.654	44.394	34.392	-11.606	56.000	10.002	QP
12			4.654	29.531	19.529	-16.469	46.000	10.002	AV

Note: Measure Level (dBuV) = Reading Level (dBuV) + Factor (dB)

Factor (dB) = Cable Loss (dB) + LISN Factor (dB)

Site: SR2	Time: 2018/11/20 - 15:03
Limit: FCC_Part15.207_CE_AC Power_ClassB	Engineer: Cloud Guo
Probe: ENV216_101683_Filter On	Polarity: Neutral
EUT: Dual band wifi module	Power: AC 120V/60Hz
Test Mode 1	

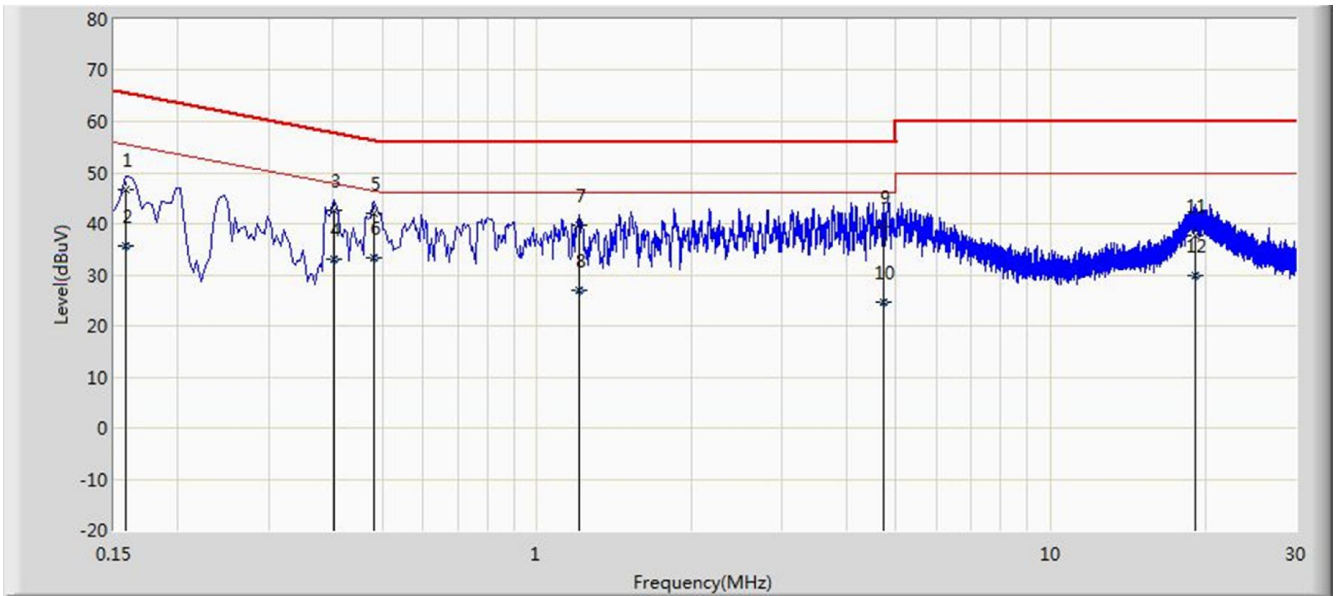

No	Flag	Mark	Frequency (MHz)	Measure Level (dBuV)	Reading Level (dBuV)	Over Limit (dB)	Limit (dBuV)	Factor (dB)	Type
1			0.158	46.713	36.423	-18.856	65.568	10.290	QP
2			0.158	35.752	25.463	-19.816	55.568	10.290	AV
3			0.402	42.622	32.508	-15.190	57.812	10.114	QP
4		*	0.402	33.173	23.060	-14.638	47.812	10.114	AV
5			0.482	42.114	31.941	-14.190	56.305	10.173	QP
6			0.482	33.332	23.159	-12.973	46.305	10.173	AV
7			1.206	39.796	29.894	-16.204	56.000	9.902	QP
8			1.206	27.008	17.106	-18.992	46.000	9.902	AV
9			4.714	39.342	29.323	-16.658	56.000	10.019	QP
10			4.714	24.657	14.637	-21.343	46.000	10.019	AV
11			19.166	37.748	27.589	-22.252	60.000	10.159	QP
12			19.166	29.915	19.757	-20.085	50.000	10.159	AV

Note: Measure Level (dBuV) = Reading Level (dBuV) + Factor (dB)

Factor (dB) = Cable Loss (dB) + LISN Factor (dB)

## 7. CONCLUSION

The data collected relate only the item(s) tested and show that the **Dual band wifi module** is in compliance with Part 15E of the FCC Rules.

\_\_\_\_\_ The End \_\_\_\_\_

## **Appendix A - Test Setup Photograph**

Refer to "1811WSU012-UT" file.

## **Appendix B - EUT Photograph**

Refer to "1811WSU012-UE" file.