

WF60 User manual

Amp'ed RF Technology, Inc.

WF60 Product Specification



13.5mm x 14.6mm x 2.7 mm

Description

Amp'ed RF Tech presents the WF60 dual band WiFi module: 802.11abgn. The WF60 is a small footprint low cost RF module intended to help customers shorten product development cycles and reduce cost. It's fully compatible with Linux & Android systems, or our own upper layer stack, Amp'ed UP, for a complete host & controller solution.

Features

WLAN

- 802.11a: OFDM
- 802.11b: DSSS
- 802.11g/n-HT20: OFDM
- Dual Band: 2.4GHz and 5GHz
- Lower sub-band: U-NII-1: 5150-5250MHz
- Higher sub-band: U-NII-3: 5725-5850MHz
- Output Power, +22.5dBm
- Power savings mode
- Transmit power back-off
- Wi-Fi Direct (concurrent)
- Wi-Fi Display
- Wi-Fi Protected Setup
- Soft Access Point
- Hotspot 2.0
- Security: WPA1/WPA2, AES, WEP

Hardware

- Interface, SDIO 2.0 or SPI
- 1 LPO input
- Standby current, 40 μ A
- RoHS conformance
- FCC/IC certified TBD

Contents

1. Hardware Specifications	4
1.1. Recommended Operating Conditions.....	4
1.2. Absolute Maximum Ratings	4
1.3. I/O Operating Conditions	4
2. Hardware Block Diagram.....	5
3. Hardware Design.....	6
4. Startup behavior	8
4.1. RESET and PMUEN.....	8
4.2. SDIO and SPI interface	8
5. Regulatory Compliance	8
5.1. Modular Approval, FCC and IC.....	10
5.2. FCC Label Instructions	10

1. Hardware Specifications

General Conditions (VIN= 3.6V and 25°C)

1.1. Recommended Operating Conditions

Rating	Min	Typical	Max	Unit
Operating Temperature Range	-10	-	60	°C
Supply Voltage VIN	2.3	3.6	4.8	Volts
Signal Pin Voltage	-	1.8	-	Volts
RF Frequency	2400	-	2483.5	MHz

1.2. Absolute Maximum Ratings

Rating	Min	Typical	Max	Unit
Storage temperature range	-55	-	+150	°C
Supply voltage VIN	-0.3	-	+5.0	Volts
I/O pin voltage VIO	-0.3	-	+2.5	Volts
RF input power	-	-	-5	dBm

1.3. I/O Operating Conditions

Symbol	Parameter	Min	Max	Unit
V _{IL}	Low-Level Input Voltage	-	0.6	Volts
V _{IH}	High-Level Input Voltage	1.3	-	Volts
V _{OL}	Low-Level Output Voltage	-	0.2	Volts
V _{OH}	High-Level Output Voltage	1.6	-	Volts
I _{OL}	Low –Level Output Current	-	4.0	mA
I _{OH}	High-Level Output Current	-	4.0	mA
R _{PU}	Pull-up Resistor	80	120	KΩ
R _{PD}	Pull-down Resistor	80	120	KΩ

2. Hardware Block Diagram

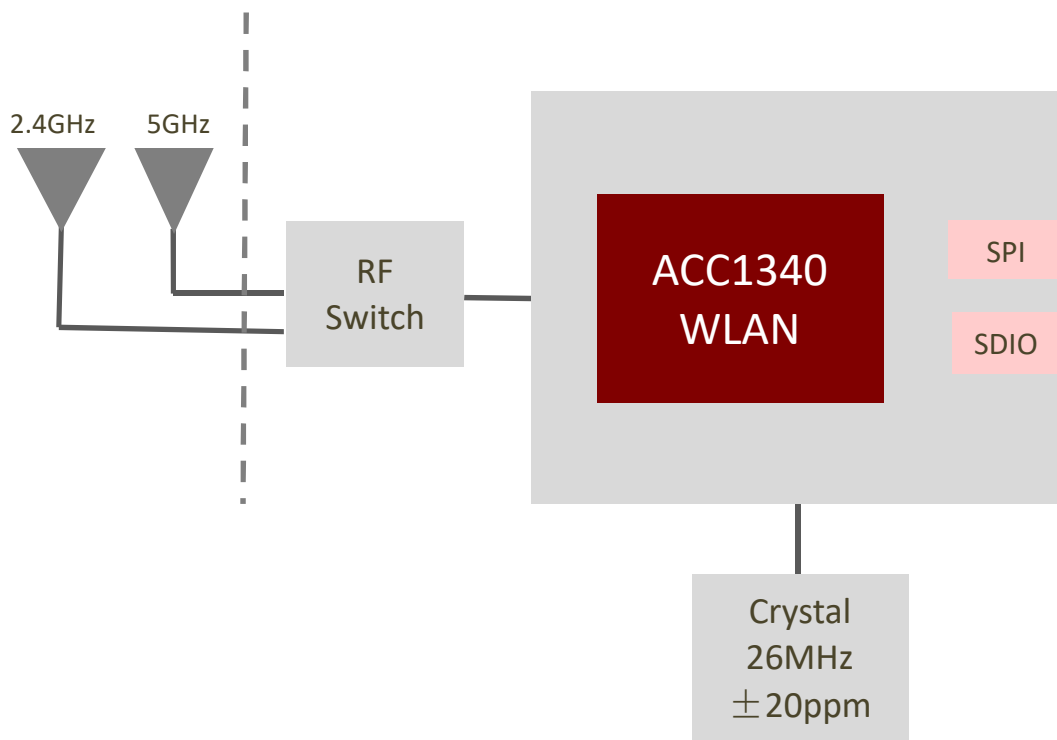

3. Hardware Design

- All unused pins should be left floating; do not ground.
- All GND pins must be well grounded.
- The area around the antenna should be free of any ground planes, power planes, trace routings, or metal for at least 6.5 mm in all directions.
- Traces should not be routed underneath the module.
- ANT 2.4G and ANT 5G:RF bi-directional antenna port matched to 50Ω, molex 1461530100.

ELECTRICAL REQUIREMENTS FOR CABLE LENGTH 100mm (1461530100)

DESCRIPTION	TEST CONDITION	REQUIREMENT	
		2.4GHz~2.5GHz	5.15GHz~5.85GHz
Frequency Range	2.4GHz~5.85GHz	2.4GHz~2.5GHz	5.15GHz~5.85GHz
Return Loss	Antenna loaded on PC/ABS housing with 100mm long, 1.13mm diameter micro coaxial cable. Measured by VNA5071C	< -10 dB	
Peak Gain	Measure antenna on recommended PC/ABS housing through OTA chamber	3.0 dBi	4.5 dBi
Total Efficiency	Measure antenna on recommended PC/ABS housing through OTA chamber	>75%	>70%
Polarization	Measure antenna through the OTA chamber	Linear	
Input Impedance	Measure antenna on recommended PC/ABS housing through VNA E5071C	50 Ohms	

- RF traces must be as short as possible for best RF performance, like below.

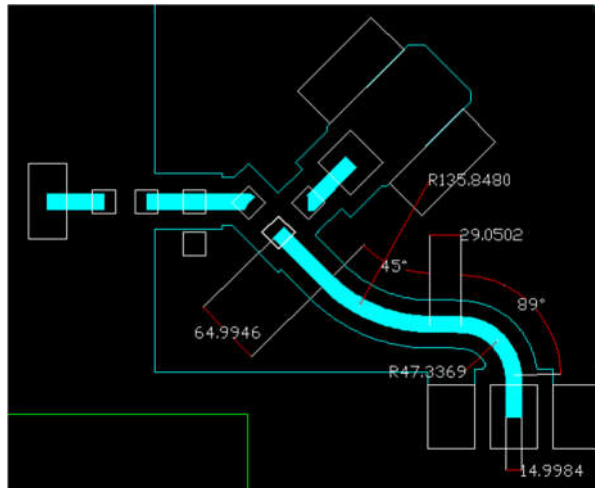

- RF traces must be routed on the top layer, far away from other high speed signal traces.
- Digital traces should not be placed directly under RF trace layers.
- All RF traces must have a solid ground plane below.

3.1. Module Reflow Installation

The WF60 is a surface mount Bluetooth module supplied on a 18 pin, 6-layer PCB. The final assembly recommended reflow profiles are:

For RoHS/Pb-free applications, Sn96.5/Ag3.0/Cu0.5 solder is recommended.

- Maximum peak temperature of 230° - 240°C (below 250°C).
- Maximum rise and fall slope after liquidous of < 2°C/second.
- Maximum rise and fall slope after liquidous of < 3°C/second.
- Maximum time at liquidous of 40 – 80 seconds.

4. Startup behavior

4.1. RESET and PMUEN

A valid reset shall be obtained by maintaining RESET active (low) for at least two cycles of LPO after VIN is stable within its operating range. There is no constraint on the activation of the other supplies during this process.

4.2. SDIO and SPI interface

SDIO 5 is the selection pin; the state of this pin is monitored on the rising edge of RESET.

- LOW selects SPI
- HIGH selects SDIO

5. Regulatory Compliance

Federal Communications Commission statement:

This module has been tested and found to comply with the FCC Part15.

These limits are designed to provide reasonable protection against harmful interference in approved installations. This equipment generates, uses, and can radiate radio frequency energy and, if not installed and used in accordance the instructions, may cause harmful interference to radio communications. However, there is no guarantee that interference will not occur in a particular installation.

This device complies with part 15 of the FCC Rules. Operation is subject to the following two conditions: (1) This device may not cause harmful interference, and (2) this device must accept any interference received, including interference that may cause undesired operation.

Modifications or changes to this equipment not expressly approved by Amp'ed RF Technology may void the user's authority to operate this equipment.

The modular transmitter must be equipped with either a permanently affixed label or must be capable of electronically displaying its FCC identification number

(A) Host labeling requirement: Contains FCC ID: X3ZWFMOD10

The module is a limited single module without completed shielding case, CIIPC or new filing shall be applied for any host equipment using this module, such as provide the completed shielding case for this module.

(B) If the modular transmitter uses an electronic display of the FCC identification number, the information must be readily accessible and visible on the modular transmitter or on the device in which it is installed. If the module is installed inside another device, then the outside of the device into which the module is installed must display a label referring to the enclosed module. This exterior label can use wording such as the following: "Contains FCC certified transmitter module(s)."

To satisfy FCC RF Exposure requirements for mobile and base station transmission devices, a separation distance of 20 cm or more should be maintained between the antenna of this device and persons during operation. To ensure compliance, operation at closer than this distance is not recommended. The antenna(s) used for this transmitter must not be co-located or operating in conjunction with any other antenna or transmitter.

(C) This equipment has been tested and found to comply with the limits for a Class B digital device, pursuant to part 15 of the FCC Rules. These limits are designed to provide reasonable protection against harmful interference in a residential installation. This equipment generates, uses and can radiate radio frequency energy and, if not installed and used in accordance with the instructions, may cause harmful interference to radio communications. However, there is no guarantee that interference will not occur in a particular installation. If this equipment does cause harmful interference to radio or television reception, which can be determined by turning the equipment off and on, the user is encouraged to try to correct the interference by one or more of the following measures:

- Reorient or relocate the receiving antenna.
- Increase the separation between the equipment and receiver.
- Connect the equipment into an outlet on a circuit different from that to which the receiver is connected.
- Consult the dealer or an experienced radio/TV technician for help.

Industry Canada statement:

Label of the end product:

The final end product must be labeled in a visible area with the following "Contains transmitter module IC: 8828A-MOD10"

This Class B digital apparatus complies with Canadian ICES-003.

This device contains licence-exempt transmitter(s)/receiver(s) that comply with Innovation, Science and Economic Development Canada's licence-exempt RSS(s). Operation is subject to the following two conditions:

- (1) This device may not cause interference; and
- (2) This device must accept any interference, including interference that may cause undesired operation of the device.

L'émetteur/récepteur exempt de licence contenu dans le présent appareil est conforme aux CNR d'Innovation, Sciences et Développement économique Canada applicables aux appareils radio exempts de licence. L'exploitation est autorisée aux deux conditions suivantes :

- (1) L'appareil ne doit pas produire de brouillage;
- (2) L'appareil doit accepter tout brouillage radioélectrique subi, même si le brouillage est

susceptible d'en compromettre le fonctionnement.

This equipment complies with radio frequency exposure limits set forth by the Innovation, Science and Economic Development Canada for an uncontrolled environment.

This equipment should be installed and operated with a minimum distance of 20 cm between the device and the user or bystanders.

This device must not be co-located or operating in conjunction with any other antenna or transmitter.

Cet équipement est conforme aux limites d'exposition aux radiofréquences définies par la Innovation, Sciences et Développement économique Canada pour un environnement non contrôlé.

Cet équipement doit être installé et utilisé avec un minimum de 20 cm de distance entre le dispositif et l'utilisateur ou des tiers.

Ce dispositif ne doit pas être utilisé à proximité d'une autre antenne ou d'un autre émetteur.

5.1. Modular Approval, FCC and IC

FCC ID: X3ZWFMOD10

IC: 8828A-MOD10

In accordance with FCC Part 15, the WF60 is listed above as a Limited Modular Transmitter device.

5.2. FCC Label Instructions

The outside of final products that contain a WF60 device must display a label referring to the enclosed module. This exterior label can use wording such as the following:

Contains Transmitter Module

FCC ID: X3ZWFMOD10

Any similar wording that expresses the same meaning may be used.