

BT43 Datasheet
Preliminary

Amp'ed RF Technology, Inc.

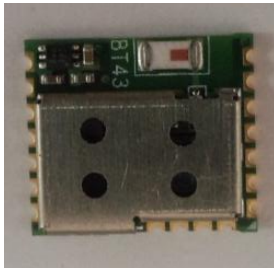

BT43LT Product Specification



11.6mm x 13.5mm

Description

Our micro-sized Bluetooth module, with integrated antenna, is the smallest form factor available providing a complete RF platform. The BT43 is supports both Bluetooth Classic and Low Energy, version v4.0.

The BT43 is a surface mount PCB module that provides fully embedded, ready to use Bluetooth wireless technology. Our standard abSerial and Amp'edUP Stack are pre-flashed into the integrated flash memory, supporting the SPP profile. Other popular Bluetooth profiles, such as OBEX, are also available.

Customized firmware for peripheral device interaction, power optimization, security, and other proprietary features may be supported and can be ordered pre-loaded and configured.

BT43 Features

Bluetooth features

- FCC & Bluetooth licensed radio
- Bluetooth v4.0
- Class 1 radio
- Range up to 80m LOS
- 1Mbps data throughput
- 128-bit encryption security

Hardware configuration

- Cortex-M3 microprocessor up to 72MHz
- 128K bytes Flash memory
- 20K bytes RAM memory
- UART, up to 2M baud
- SPI and I2C interfaces
- 7 general purpose I/O
- 4x12-bit A/D inputs
- 1 LPO input

Embedded software

- Amp'edUP dual mode Bluetooth stack: BT Classic and BT Low Energy
- abSerial, AT command set
- SDK, Software Development Kit (Optional)
- BlueGuard, data encryption software (Optional)
- Mobile application software (Optional)

Additional documentation

- abSerial User Guide
- abSerial Reference Guide
- abSerial Configuration Guide

Table of Contents

1 Software Architecture

1.1 Lower Layer Stack

- Bluetooth v4.0, Classic and Low Energy
- Device power modes: active, sleep and deep sleep
- Wake on Bluetooth feature optimized power consumption of host CPU
- Authentication and encryption
- Encryption key length from 8 to 128 bits
- Persistent FLASH memory for BD Address and user parameter storage
- All ACL packet types.
- Bluetooth test modes per Bluetooth specification
- 802.11b/g/n co-existence: AFH
- Vendor specific HCI commands to support device configuration and certification test modes

1.2 Upper Layer Stack: Amp'ed UP

- SPP, GAP, ATT, GATT
- RFCOMM, SDP, and L2CAP

1.3 HCI Interface

- Bluetooth v4.0 specification compliant
- HCI UART transport layer (H4)

1.4 AT Command Set: abSerial

- Please see *abSerial Reference Guide* for details

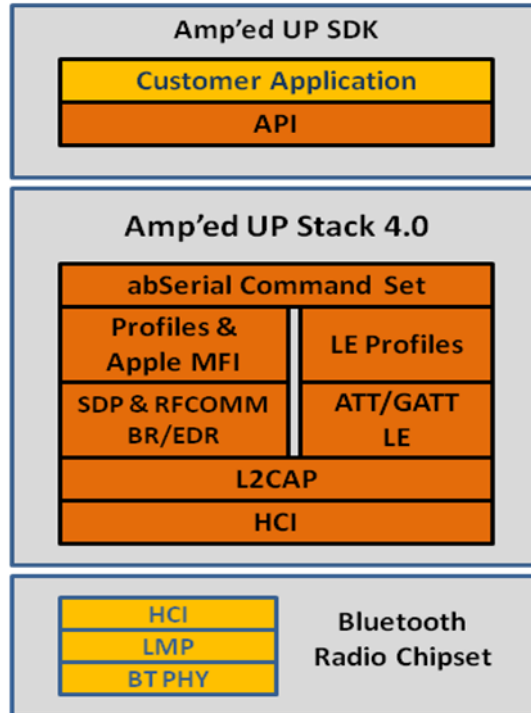

2 Hardware Specifications

General Conditions ($V_{IN}=2.5V$ and $25^{\circ}C$)

2.1 Recommended Operating Conditions

Rating	Min	Typical	Max	Unit
Operating Temperature Range	-40	-	85	$^{\circ}C$
Supply Voltage V_{IN}	2.1	2.5	3.6	Volts
Signal Pin Voltage	-	2.1	-	Volts
RF Frequency	2400	-	2483.5	MHz

2.2 Absolute Maximum Ratings

Rating	Min	Typical	Max	Unit
Storage temperature range	-55	-	+150	$^{\circ}C$
Supply voltage V_{IN}	-0.3	-	+5.0	Volts
I/O pin voltage V_{IO}	-0.3	-	+5.5	Volts
RF input power	-	-	-5	dBm

2.3 Current Consumption

Standard CPU Mode, 8 MHz <ul style="list-style-type: none"> ▪ UART supports up to 115 Kbps ▪ Data throughput up to 200 Kbps ▪ abSerial v1.5 (installed firmware) ▪ Shallow Sleep enabled 		
Modes (Typical Power Consumption)	Avg	Unit
ACL data 115K Baud UART at max throughput (Master)	17.5	mA
ACL data 115K Baud UART at max throughput (Slave)	19.5	mA
Connection, no data traffic, master	5.2	mA
Connection, no data traffic, slave	7.4	mA
Connection, 375ms sniff, slave (external LPO required)	590	μA
Standby, without deep sleep	5.2	mA
Standby, with deep sleep, no external LPO	1.7	mA
Standby, with deep sleep, with external LPO	140	μA
Page/Inquiry Scan, with deep sleep, no external LPO	2.6	mA
Page/Inquiry Scan, with deep sleep, with external LPO	720	μA
BLE Advertising, 1.28s, non-connectable, with external LPO	195	μA
BLE Advertising, 1.28s, discoverable, with external LPO	215	μA
Bluetooth power down / CPU standby	11	μA

2.4 Selected RF Characteristics

Parameters	Conditions	Typical	Unit
Antenna load		50	ohm
Radio Receiver			
Sensitivity level	BER < .001 with DH5	-92	dBm
Maximum usable level	BER < .001 with DH1	0	dBm
Input VSWR		2.5:1	
Radio Transmitter			
Maximum output power	50 Ω load	+9	dBm
Initial Carrier Frequency Tolerance		0	kHz
20 dB Bandwidth for modulated carrier		935	kHz

2.5 I/O Operating Characteristics

Symbol	Parameter	Min	Max	Unit	Conditions
V _{IL}	Low-Level Input Voltage	-	0.6	Volts	V _{IN} , 2.1V
V _{IH}	High-Level Input Voltage	1.4	-	Volts	V _{IN} , 2.1V
V _{OL}	Low-Level Output Voltage	-	0.4	Volts	V _{IN} , 2.1V
V _{OH}	High-Level Output Voltage	1.8	-	Volts	V _{IN} , 2.1V
I _{OL}	Low -Level Output Current	-	4.0	mA	V _{OL} = 0.4 V
I _{OH}	High-Level Output Current	-	4.0	mA	V _{OH} = 1.8V
R _{PU}	Pull-up Resistor	80	120	KΩ	Resistor Turned On
R _{PD}	Pull-down Resistor	80	120	KΩ	Resistor Turned On

2.6 Pin Assignment

Name	Type	Pin #	Description	ALT Function	5V Tolerant	Initial State
UART Interface						
RXD	I	13	Receive data		Y	
TXD	O	14	Transmit data		Y	
RTS	O	12	Request to send (active low)		Y	
CTS	I	11	Clear to send (active low)		Y	
Reserved						
BOOT 0	I	9	Reserved			
Power and Ground						
V _{in}		8	V _{in}			
GND		7	GND			
Reset						
RESETN	I	10	Reset input (active low for 5 ms);		2.5V max	
LPO						
LPO	I	15	Low power clock input			
System CLK						
SYSCLK	I	16	System clock input			
Antenna						
Antenna	O	18	GPS Antenna			
GPIO – General Purpose Input/Output						
GPIO [1]	I/O	1	General Purpose Input/Output	SPI MISO	Y	Input pull down
GPIO [2]	I/O	2	General Purpose Input/Output	SPI MOSI/I2S_SD	Y	Floating
GPIO [3]	I/O	3	General Purpose Input/Output	SPI SCLK/ I2S_SCK	Y	Input pull down
GPIO [4]	I/O	4	General Purpose Input/Output	SPI SS/I2S_WS	Y	Input pull down
GPIO [5]	I/O	5	General Purpose Input/Output		Y	Input pull down
GPIO [6]	I/O	6	General Purpose Input/Output	ADC1	Y	Input pull down
GPIO [7]	I/O	17	General Purpose Input/Output	ADC2	Y	Input pull down

2.7 Pin Placement Diagram (Top View)

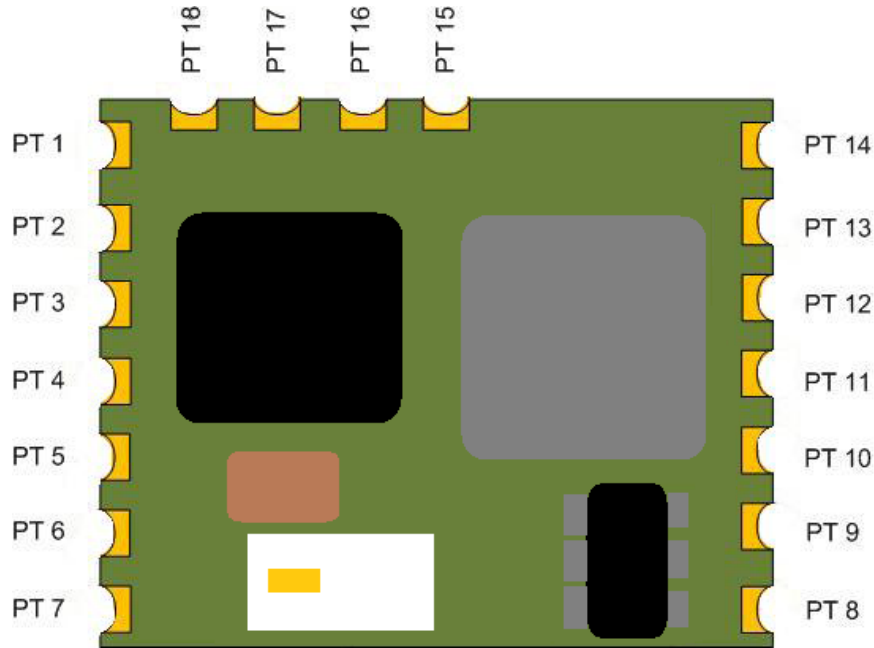

2.8 Layout Drawing

Size: 11.6 mm x 13.5 mm x 2.2 mm (height)

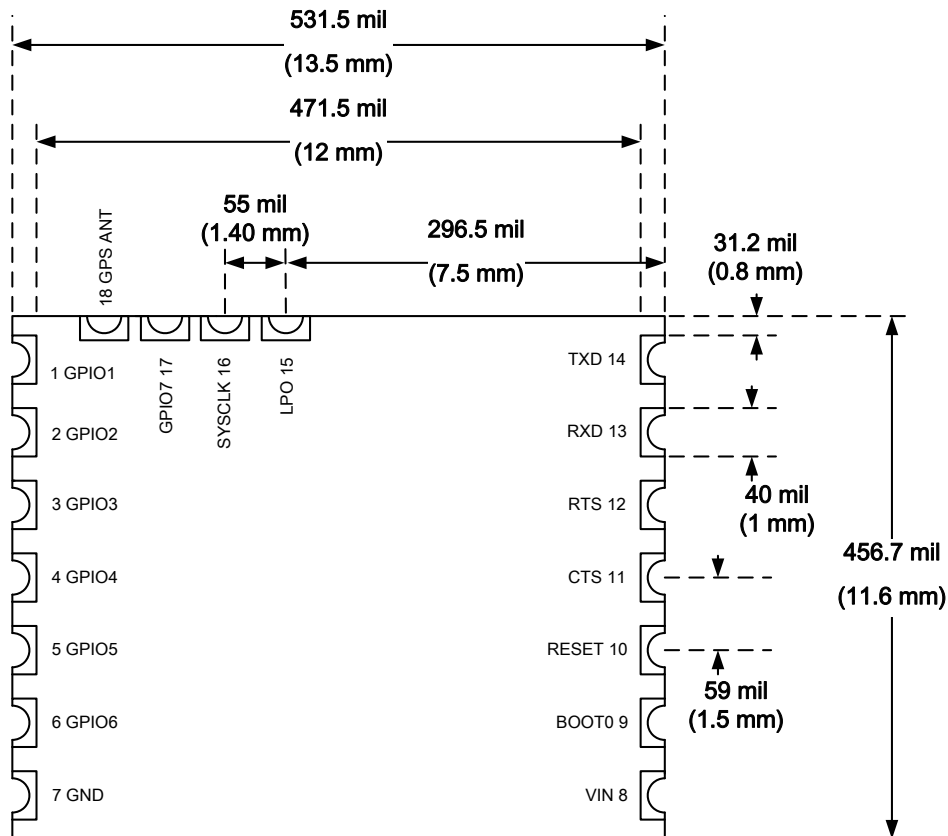

3 Module Block Diagram

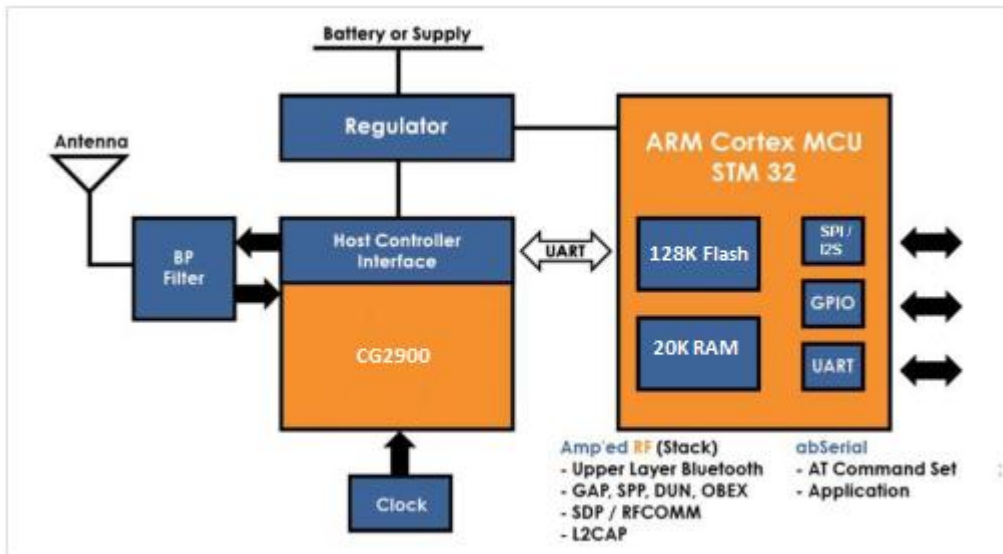

4 Hardware Design

Amp'ed RF modules support UART, USB, SPI, and GPIO hardware interfaces. Please note that the usage of these interfaces is dependent upon the firmware that is loaded into the module, and is beyond the scope of this document. The AT command interface uses the main UART by default.

Notes

- All unused pins should be left floating; do not ground.
- All GND pins must be well grounded.
- The area around the antenna should be free of any ground planes, power planes, trace routings, or metal for at least 6 mm in all directions.
- Traces should not be routed underneath the module.

4.1 Module Reflow Installation

The BT43 is a surface mount Bluetooth module supplied on a 16 pin, 6-layer PCB. The final assembly recommended reflow profiles are:

For RoHS/Pb-free applications, Sn96.5/Ag3.0/Cu0.5 solder is recommended.

- Maximum peak temperature of 230° - 240°C (below 250°C).
- Maximum rise and fall slope after liquidous of < 2°C/second.
- Maximum rise and fall slope after liquidous of < 3°C/second.
- Maximum time at liquidous of 40 – 80 seconds.

4.2 GPIO Interface

All GPIOs are capable of sinking and sourcing 4mA of I/O current.

4.3 UART Interface

The UART is compatible with the 16550 industry standard. Four signals are provided with the UART interface. The TXD and RXD pins are used for data while the CTS and RTS pins are used for flow control.

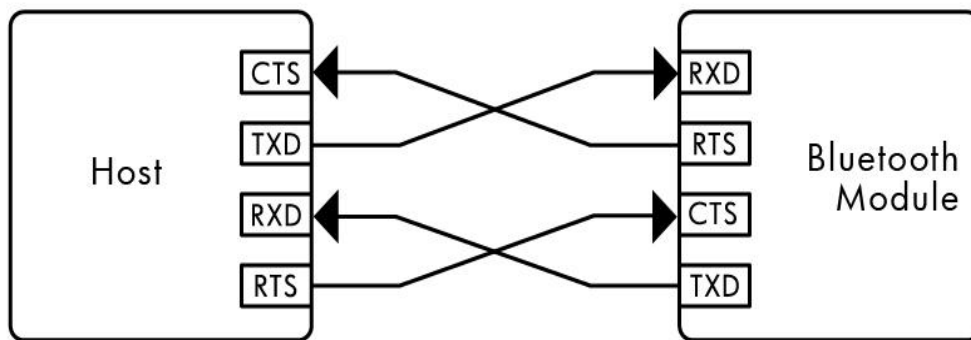

Connection to Host Device

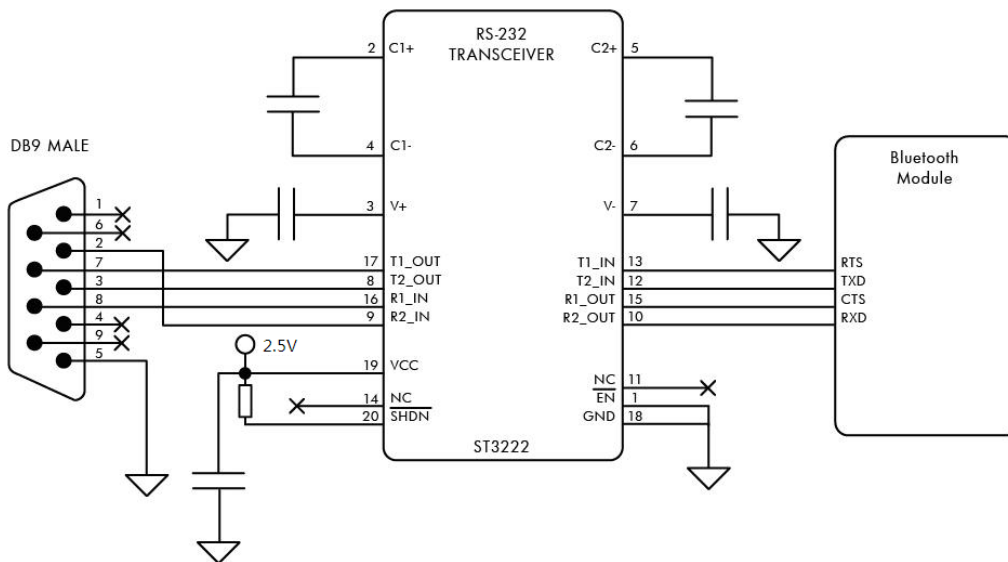

Typical RS232 Circuit

4.4 PCB Layout Guidelines

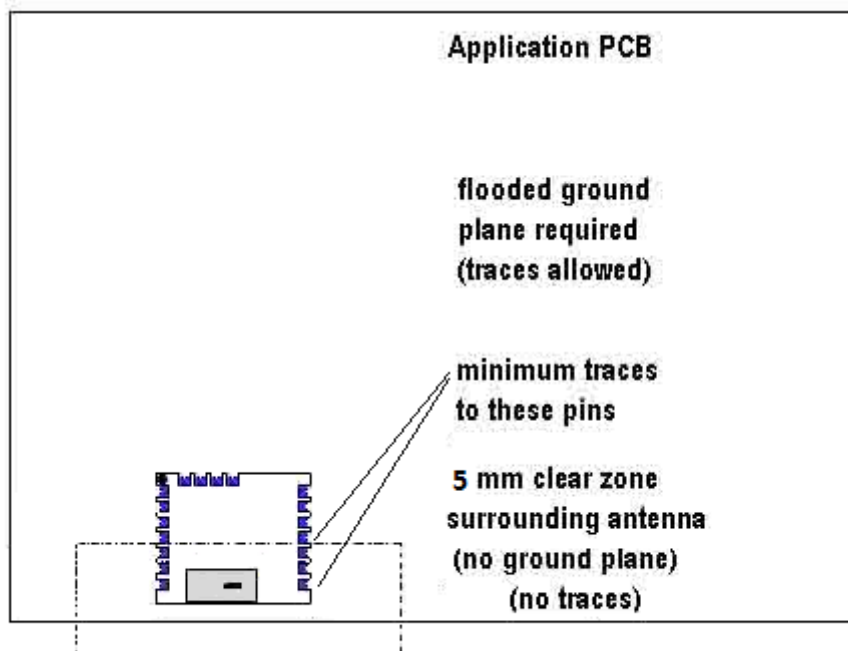

4.5 Reset Circuit

Two types of system reset circuits are detailed below.

4.5.1 External Reset Circuit:

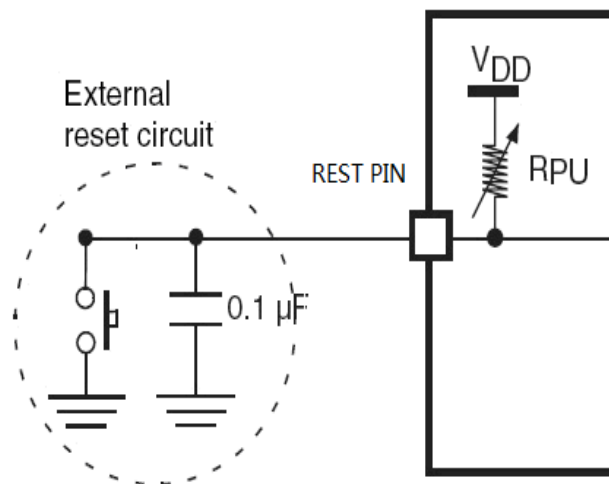

Note: R_{PU} ranges from 30K ohm to 50K ohm internally.

4.5.2 Internal Reset Circuit:

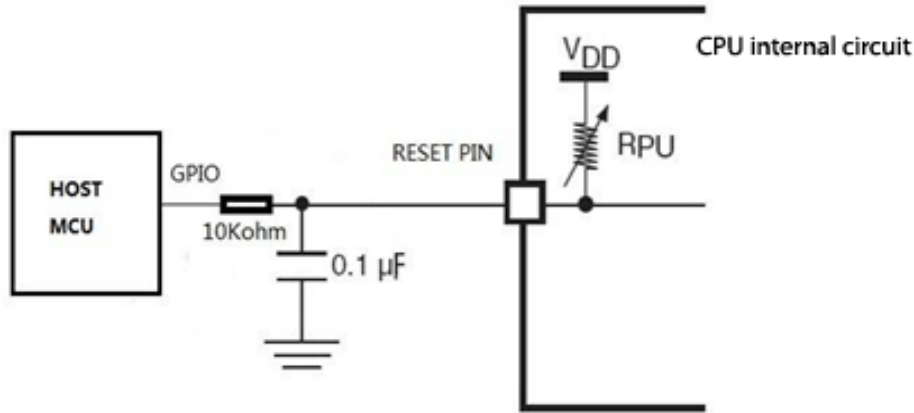

Notes:

- R_{PU} ranges from 30K ohm to 50K ohm internally.
- R_{RST} should be from 1K ohm to 10K ohm

4.6 External LPO Input Circuit

An optional low power oscillator input may be added to allow deep sleep and sniff modes.

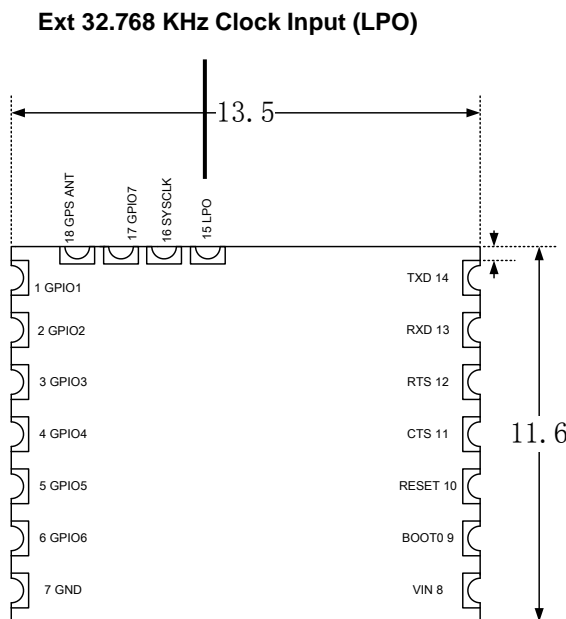

LPO Parameters:

Frequency: 32.768 KHz

Tolerance: 150 ppm

Voltage Levels:

Low: 0.5 V

High: 1.8 V

Input Capacitance: 2.5 pF maximum

Configurations:

See configuration guide:

UseExtLPO

AllowSniff

5 Regulatory Compliance

This device complies with Part 15 of the FCC Rules and with RSS-210 of Industry Canada.

Operation is subject to the following two conditions:

(1) this device may not cause harmful interference, and (2) this device must accept any interference received, including interference that may cause undesired operation.

Cet dispositif est conforme à la norme CNR-210 d'Industrie Canada applicable aux appareils radio exempts de licence. Son fonctionnement est sujet aux deux conditions suivantes:

(1) le dispositif ne doit pas produire de brouillage préjudiciable, et (2) ce dispositif doit accepter tout brouillage reçu, y compris un brouillage susceptible de provoquer fonctionnement indésirable.

The radiated output power of the device is far below the FCC radio frequency exposure limits. Nevertheless, the device shall be used in such a manner that the potential for human contact during normal operation is minimized.

Modifications or changes to this equipment not expressly approved by Amp'ed RF Technology may void the user's authority to operate this equipment.

This Class B digital apparatus complies with Canadian ICES-003.

Cet appareil numérique de la classe B est conforme à la norme NMB-003 du Canada.

The modular transmitter must be equipped with either a permanently affixed label or must be capable of electronically displaying its FCC identification number

(A) If using a permanently affixed label, the modular transmitter must be labeled with its own FCC identification number, and, if the FCC identification number is not visible when the module is installed inside another device, then the outside of the device into which the module is installed must also display a label referring to the enclosed module. This exterior label can use wording such as the following: "Contains Transmitter Module FCC ID: X3ZBTMOD7" or "Contains FCC ID: X3ZBTMOD7."

(B) If the modular transmitter uses an electronic display of the FCC identification number, the information must be readily accessible and visible on the modular transmitter or on the device in which it is installed. If the module is installed inside another device, then the outside of the device into which the module is installed must display a label referring to the enclosed module. This

exterior label can use wording such as the following: “Contains FCC certified transmitter module(s).”

6 Ordering Information

Part Name	Description
BT43-LT	Standard version

7 Revision History

Date	Revision	Description
30 Oct 2012	1	First release
16 Jan 2013	1.1	Updated power consumption table