



# RADIO TEST REPORT

Report No: STS1912347W02

Issued for

ELMO COMPANY, LIMITED

1-3-4, Shioya-cho, Minami-ku, Nagoya-city Aichi, 457-0078  
Japan

<b>Product Name:</b>	Wireless Pen Tablet
<b>Brand Name:</b>	
<b>Model Name:</b>	CRA-2
<b>Series Model:</b>	N/A
<b>FCC ID:</b>	X3X-CRA-2
<b>IC:</b>	8804A-X3XCRA2
<b>Test Standard:</b>	FCC Part 15.249
	RSS 210 Issue 9

Any reproduction of this document must be done in full. No single part of this document may be reproduced without permission from STS. All Test Data Presented in this report is only applicable to presented Test sample.





TEST RESULT CERTIFICATION

Applicant's Name .....: ELMO COMPANY, LIMITED
Address .....: 1-3-4, Shioya-cho, Minami-ku, Nagoya-city Aichi, 457-0078 Japan
Manufacture's Name .....: ELMO COMPANY, LIMITED
Address .....: 1-3-4, Shioya-cho, Minami-ku, Nagoya-city Aichi, 457-0078 Japan
Factory's Name.....: Shenzhen Huion Animation Technology Co.,ltd
Address .....: Building 28, Quater 4, HuaiDeCuiGang Industrial Park, Fuyong Street, Bao'anDistrict, Shenzhen, China

Product Description

Product Name .....: Wireless Pen Tablet
Brand Name .....: ELMO
Model Name .....: CRA-2
Series Model .....: N/A
Test Standards.....: FCC Part15.249
RSS 210 Issue 9
Test Procedure .....: ANSI C63.10-2013

This device described above has been tested by STS, the test results show that the equipment under test (EUT) is in compliance with the FCC requirements. And it is applicable only to the tested sample identified in the report.
This report shall not be reproduced except in full, without the written approval of STS, this document only be altered or revised by STS, personal only, and shall be noted in the revision of the document.

Date of Test .....:
Date of receipt of test item .....: 26 Dec. 2019
Date of performance of tests ...: 26 Dec. 2019 ~ 10 Jan. 2020
Date of Issue .....: 10 Jan. 2020
Test Result.....: Pass

Testing Engineer : [Signature]

(Chris Chen)

Technical Manager : [Signature]

(Sunday Hu)

Authorized Signatory : [Signature]

(Vita Li)





<b>Table of Contents</b>	<b>Page</b>
<b>1. SUMMARY OF TEST RESULTS</b>	<b>5#</b>
1.1 TEST FACTORY	6#
1.2 MEASUREMENT UNCERTAINTY	6#
<b>2. GENERAL INFORMATION</b>	<b>7#</b>
2.1 GENERAL DESCRIPTION OF THE EUT	7#
2.2 DESCRIPTION OF THE TEST MODES	9#
2.3 BLOCK DIGRAM SHOWING THE CONFIGURATION OF SYSTEM TESTED	10#
2.4 DESCRIPTION OF NECESSARY ACCESSORIES AND SUPPORT UNITS	11#
2.5 EQUIPMENTS LIST FOR ALL TEST ITEMS	12#
<b>3. EMC EMISSION TEST</b>	<b>13#</b>
3.1 CONDUCTED EMISSION MEASUREMENT	13#
3.2 RADIATED EMISSION MEASUREMENT	17#
<b>4. BANDWIDTH TEST</b>	<b>33#</b>
4.2 TEST SETUP	33#
4.3 EUT OPERATION CONDITIONS	33#
4.4 TEST RESULTS	34#
<b>5. ANTENNA REQUIREMENT</b>	<b>36#</b>
5.1 STANDARD REQUIREMENT	36#
5.2 EUT ANTENNA	36#
<b>APPENDIX- PHOTOS OF TEST SETUP</b>	<b>37#</b>



**Revision History**

Rev.	Issue Date	Report NO.	Effect Page	Contents
00	10 Jan. 2020	STS1912347W02	ALL	Initial Issue





## 1. SUMMARY OF TEST RESULTS

Test procedures according to the technical standards:

<b>FCC Part 15.249 , Subpart C RSS 210 Issue 9</b>			
Standard Section	Test Item	Judgment	Remark
15.207 RSS-Gen Issue 5 (8.8)	Conducted Emission	Pass	
15.203 RSS-Gen Issue 5	Antenna Requirement	Pass	
15.249 RSS 210 Issue 9 (B.10)	Radiated Spurious Emission	Pass	
15.205 RSS-Gen Issue 5	Radiated Band Edge Emission	Pass	
15.249 RSS-Gen Issue 5	20dB Bandwidth	Pass	
RSS-Gen Issue 5	99% Bandwidth	Pass	

**NOTE:**

- (1) 'N/A' denotes test is not applicable in this Test Report.
- (2) All tests are according to ANSI C63.10-2013.

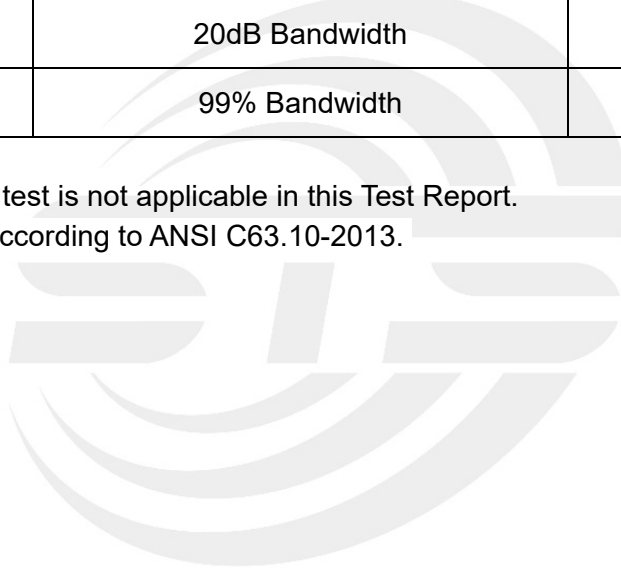



### 1.1 TEST FACTORY

SHENZHEN STS TEST SERVICES CO., LTD

Add. : A 1/F, Building B, Zhuoke Science Park, No.190 Chongqing Road, HepingShequ, Fuyong Sub-District, Bao'an District, Shenzhen, Guang Dong, China

FCC test Firm Registration Number: 625569

IC test Firm Registration Number: 12108A

A2LA Certificate No.: 4338.01

### 1.2 MEASUREMENT UNCERTAINTY

The reported uncertainty of measurement  $y \pm U$ , where expanded uncertainty  $U$  is based on a standard uncertainty multiplied by a coverage factor of  $k=2$ , providing a level of confidence of approximately **95 %**.

No.	Item	Uncertainty
1	RF output power, conducted	$\pm 0.68\text{dB}$
2	Unwanted Emissions, conducted	$\pm 2.988\text{dB}$
3	All emissions, radiated 30-1GHz	$\pm 6.7\text{dB}$
4	All emissions, radiated 1G-6GHz	$\pm 5.5\text{dB}$
5	All emissions, radiated >6G	$\pm 5.8\text{dB}$
6	Conducted Emission (9KHz-150KHz)	$\pm 4.43\text{dB}$
7	Conducted Emission (150KHz-30MHz)	$\pm 5\text{dB}$



## 2. GENERAL INFORMATION

### 2.1 GENERAL DESCRIPTION OF THE EUT

Product Name	Wireless Pen Tablet								
Trade Name									
Model Name	CRA-2								
Series Model	N/A								
Model Difference	N/A								
Product Description	<p>The EUT is a Wireless Pen Tablet</p> <table border="1"><tr><td>Operation Frequency:</td><td>2405 ~2478MHz</td></tr><tr><td>Modulation Type:</td><td>GFSK</td></tr><tr><td>Antenna Designation:</td><td>PCB</td></tr><tr><td>Antenna Gain(Peak):</td><td>3.61 dBi</td></tr></table> <p>Based on the application, features, or specification exhibited in User's Manual, the EUT is considered as an ITE/Computing Device. More details of EUT technical specification, please refer to the User's Manual.</p>	Operation Frequency:	2405 ~2478MHz	Modulation Type:	GFSK	Antenna Designation:	PCB	Antenna Gain(Peak):	3.61 dBi
Operation Frequency:	2405 ~2478MHz								
Modulation Type:	GFSK								
Antenna Designation:	PCB								
Antenna Gain(Peak):	3.61 dBi								
Channel List	Please refer to the Note 2.								
Power Rating	Input: DC 5V,500mA								
Battery	Rated Voltage: 3.7V Charge Limit: 4.2V Capacity: 1100mAh								
Hardware version number	REV04								
Software version number	20191212								

Note:

1. For a more detailed features description, please refer to the manufacturer's specifications or the User Manual.



2.

Channel List							
Channel	Frequency (MHz)	Channel	Frequency (MHz)	Channel	Frequency (MHz)	Channel	Frequency (MHz)
1	2405	21	2425	41	2445	61	2465
2	2406	22	2426	42	2446	62	2466
3	2407	23	2427	43	2447	63	2467
4	2408	24	2428	44	2448	64	2468
5	2409	25	2429	45	2449	65	2469
6	2410	26	2430	46	2450	66	2470
7	2411	27	2431	47	2451	67	2471
8	2412	28	2432	48	2452	68	2472
9	2413	29	2433	49	2453	69	2473
10	2414	30	2434	50	2454	70	2474
11	2415	31	2435	51	2455	71	2475
12	2416	32	2436	52	2456	72	2476
13	2417	33	2437	53	2457	73	2477
14	2418	34	2438	54	2458	74	2478
15	2419	35	2439	55	2459	--	--
16	2420	36	2440	56	2460	--	--
17	2421	37	2441	57	2461	--	--
18	2422	38	2442	58	2462	--	--
19	2423	39	2443	59	2463	--	--
20	2424	40	2444	60	2464	--	--

3. Table for Filed Antenna

Ant	Brand	Model Name	Antenna Type	Connector	Gain (dBi)	NOTE
1		CRA-2	PCB	N/A	3.61 dBi	Antenna





## 2.2 DESCRIPTION OF THE TEST MODES

For conducted test items and radiated spurious emissions  
Each of these EUT operation mode(s) or test configuration mode(s) mentioned below was evaluated respectively.

Pretest Mode	Description	Data/Modulation
Mode 1	TX Low channel	GFSK
Mode 2	TX Mid channel	GFSK
Mode 3	TX High channel	GFSK

Note:

- (1) All above mode have been measurement, only worst data was reported.
- (2) We have be tested for all avaiable U.S. voltage and frequencies(For 120V,50/60Hz and 240V, 50/60Hz) for which the device is capable of operation, and the worst case of 120V,50/60Hz is shown in the report.

### For AC Conducted Emission

Test Case	
AC Conducted Emission	Mode 4 : Keeping TX

### 2.3 BLOCK DIGRAM SHOWING THE CONFIGURATION OF SYSTEM TESTED

During testing channel & power controlling software provided by the customer was used to control the operating channel as well as the output power level. The RF output power selection is for the setting of RF output power expected by the customer and is going to be fixed on the firmware of the final end product power parameters.

#### Radiated Spurious Emission Test



#### Conducted Emission Test

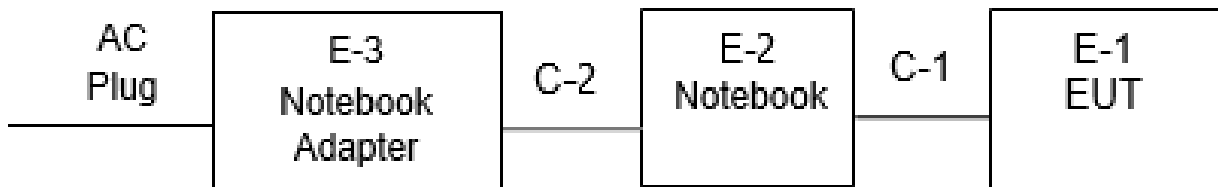



## 2.4 DESCRIPTION OF NECESSARY ACCESSORIES AND SUPPORT UNITS

The EUT has been tested as an independent unit together with other necessary accessories or support units. The following support units or accessories were used to form a representative test configuration during the tests.

### Necessary accessories

Item	Equipment	Mfr/Brand	Model/Type No.	Serial No.	Note
N/A	N/A	N/A	N/A	N/A	N/A

### Support units

Item	Equipment	Mfr/Brand	Model/Type No.	Serial No.	Note
E-2	Notebook	DELL	VOSTRO.3800	N/A	N/A
E-3	Notebook Adapter	DELL	HA45NM140	N/A	N/A
C-1	USB Cable	N/A	100cm	N/A	N/A
C-2	DC Cable	N/A	110cm	N/A	N/A

#### Note:

- (1) The support equipment was authorized by Declaration of Confirmation.
- (2) For detachable type I/O cable should be specified the length in cm in 『Length』 column.

## 2.5 EQUIPMENTS LIST FOR ALL TEST ITEMS

### Radiation Test equipment

Kind of Equipment	Manufacturer	Type No.	Serial No.	Last calibration	Calibrated until
Test Receiver	R&S	ESCI	101427	2019.07.29	2020.07.28
Signal Analyzer	Agilent	N9020A	MY51110105	2019.03.02	2020.03.01
Active loop Antenna	ZHINAN	ZN30900C	16035	2018.03.11	2021.03.10
Bilog Antenna	TESEQ	CBL6111D	34678	2017.11.02	2020.11.01
Horn Antenna	SCHWARZBECK	BBHA 9120D(1201)	9120D-1343	2018.10.19	2021.10.18
SHF-EHF Horn Antenna (18G-40GHz)	A-INFO	LB-180400-KF	J211020657	2018.03.11	2021.03.10
Pre-Amplifier(0.1M-3G Hz)	EM	EM330	060665	2019.10.09	2020.10.08
Pre-Amplifier (1G-18GHz)	SKET	LNPA-01018G-45	SK201808090 1	2019.10.09	2020.10.08
Temperature & Humidity	HH660	Mieo	N/A	2019.10.09	2020.10.08
turn table	EM	SC100_1	60531	N/A	N/A
Antenna mast	EM	SC100	N/A	N/A	N/A
Test SW	FARAD	EZ-EMC(Ver.STSLAB-03A1 RE)			

### Conduction Test equipment

Kind of Equipment	Manufacturer	Type No.	Serial No.	Last calibration	Calibrated until
Test Receiver	R&S	ESCI	101427	2019.7.29	2020.7.28
LISN	R&S	ENV216	101242	2019.10.9	2020.10.8
LISN	EMCO	3810/2NM	23625	2019.10.9	2020.10.8
Temperature & Humidity	HH660	Mieo	N/A	2019.10.12	2020.10.11
Test SW	FARAD	EZ-EMC(Ver.STSLAB-03A1 CE)			

### RF Connected Test

Kind of Equipment	Manufacturer	Type No.	Serial No.	Last calibration	Calibrated until
USB RF power sensor	DARE	RPR3006W	15I00041SNO03	2019.10.09	2020.10.08
Signal Analyzer	Agilent	N9020A	MY49100060	2019.10.09	2020.10.08
Temperature & Humidity	HH660	Mieo	N/A	2019.10.12	2020.10.11
Test SW	FARAD	LZ-RF /LzRf-3A3			

### 3. EMC EMISSION TEST

#### 3.1 CONDUCTED EMISSION MEASUREMENT

##### 3.1.1 POWER LINE CONDUCTED EMISSION LIMITS

Operating frequency band. In case the emission fall within the restricted band specified on Part 15.249 and RSS-Gen limit in the table below has to be followed.

FREQUENCY (MHz)	Quasi-peak	Average
0.15 -0.5	66 - 56 *	56 - 46 *
0.50 -5.0	56.00	46.00
5.0 -30.0	60.00	50.00

Note:

- (1) The tighter limit applies at the band edges.
- (2) The limit of “ \* ” marked band means the limitation decreases linearly with the logarithm of the frequency in the range.

The following table is the setting of the receiver

Receiver Parameters	Setting
Attenuation	10 dB
Start Frequency	0.15 MHz
Stop Frequency	30 MHz
IF Bandwidth	9 kHz

### 3.1.2 TEST PROCEDURE

- a. The EUT was 0.8 meters from the horizontal ground plane and 0.4 meters from the vertical ground plane with EUT being connected to the power mains through a line impedance stabilization network (LISN). All other support equipments powered from additional LISN(s). The LISN provide 50 Ohm/ 50uH of coupling impedance for the measuring instrument.
- b. Interconnecting cables that hang closer than 40 cm to the ground plane shall be folded back and forth in the center forming a bundle 30 to 40 cm long.
- c. I/O cables that are not connected to a peripheral shall be bundled in the center. The end of the cable may be terminated, if required, using the correct terminating impedance. The overall length shall not exceed 1 m.
- d. LISN at least 80 cm from nearest part of EUT chassis.
- e. For the actual test configuration, please refer to the related Item –EUT Test Photos.

### 3.1.3 TEST SETUP

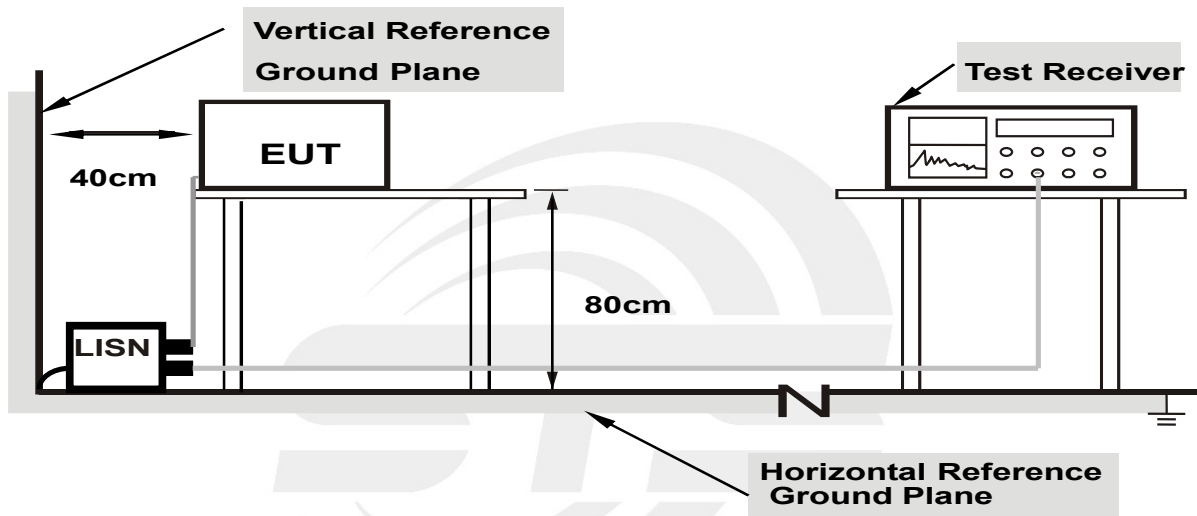

- Note: 1.Support units were connected to second LISN.  
 2.Both of LISNs (AMN) are 80 cm from EUT and at least 80 from other units and other metal planes**

### 3.1.4 EUT OPERATING CONDITIONS

The EUT was configured for testing in a typical fashion (as a customer would normally use it). The EUT has been programmed to continuously transmit during test. This operating condition was tested and used to collect the included data.



3.1.5 TEST RESULT

Temperature:	23.1(C)	Relative Humidity:	46%RH
Test Voltage:	AC 120V/60Hz	Phase:	L
Test Mode:	Mode 4		

No.	Frequency (MHz)	Reading (dBUV)	Correct Factor(dB)	Result (dBUV)	Limit (dBUV)	Margin (dB)	Remark
1	0.1580	35.86	19.76	55.62	65.57	-9.95	QP
2	0.1580	16.35	19.76	36.11	55.57	-19.46	AVG
3	0.4700	18.24	19.99	38.23	56.51	-18.28	QP
4	0.4700	6.17	19.99	26.16	46.51	-20.35	AVG
5	1.5060	13.50	19.74	33.24	56.00	-22.76	QP
6	1.5060	3.81	19.74	23.55	46.00	-22.45	AVG
7	2.6580	11.41	19.74	31.15	56.00	-24.85	QP
8	2.6580	1.42	19.74	21.16	46.00	-24.84	AVG
9	7.8780	10.62	19.89	30.51	60.00	-29.49	QP
10	7.8780	0.75	19.89	20.64	50.00	-29.36	AVG
11	14.0940	14.77	20.10	34.87	60.00	-25.13	QP
12	14.0940	5.74	20.10	25.84	50.00	-24.16	AVG

Remark:

1. All readings are Quasi-Peak and Average values.
2. Margin = Result (Result =Reading + Factor )–Limit

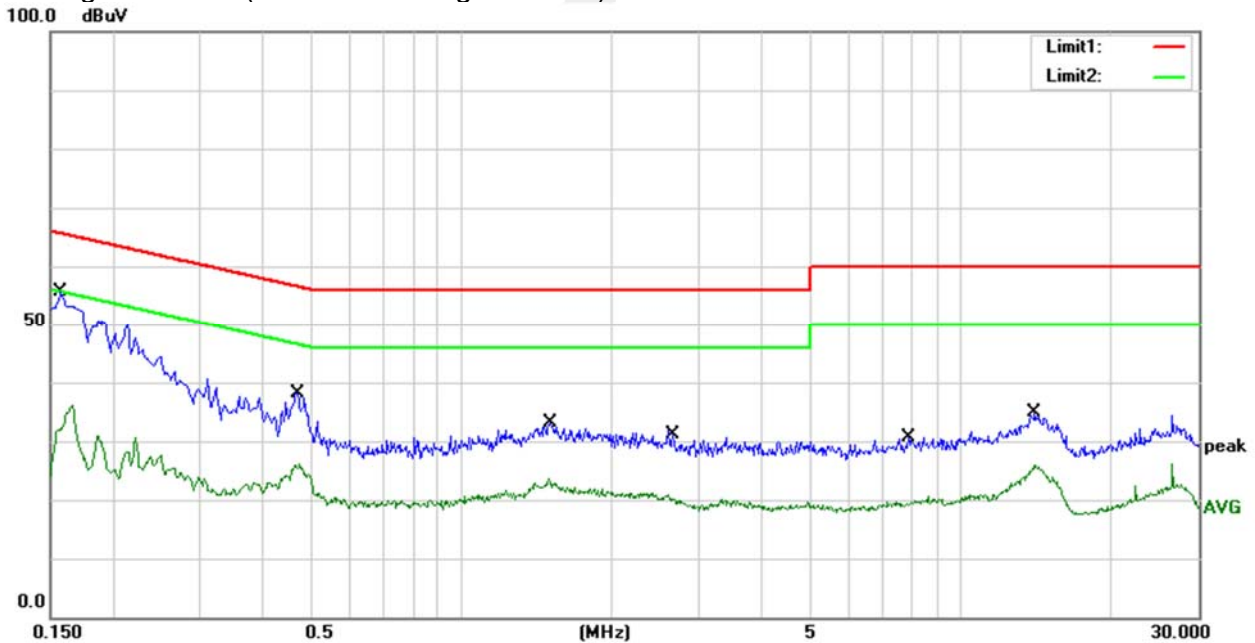



Temperature:	23.1(C)	Relative Humidity:	46%RH
Test Voltage:	AC 120V/60Hz	Phase:	N
Test Mode:	Mode 4		

No.	Frequency (MHz)	Reading (dBuV)	Correct Factor(dB)	Result (dBuV)	Limit (dBuV)	Margin (dB)	Remark
1	0.1700	33.99	19.76	53.75	64.96	-11.21	QP
2	0.1700	17.31	19.76	37.07	54.96	-17.89	AVG
3	0.4740	17.17	19.99	37.16	56.44	-19.28	QP
4	0.4740	6.72	19.99	26.71	46.44	-19.73	AVG
5	1.4580	15.83	19.74	35.57	56.00	-20.43	QP
6	1.4580	6.40	19.74	26.14	46.00	-19.86	AVG
7	3.1580	8.46	19.75	28.21	56.00	-27.79	QP
8	3.1580	-0.86	19.75	18.89	46.00	-27.11	AVG
9	7.8300	8.98	19.89	28.87	60.00	-31.13	QP
10	7.8300	-1.55	19.89	18.34	50.00	-31.66	AVG
11	14.2860	13.87	20.10	33.97	60.00	-26.03	QP
12	14.2860	1.14	20.10	21.24	50.00	-28.76	AVG

Remark:

1. All readings are Quasi-Peak and Average values.
2. Margin = Result (Result =Reading + Factor )–Limit

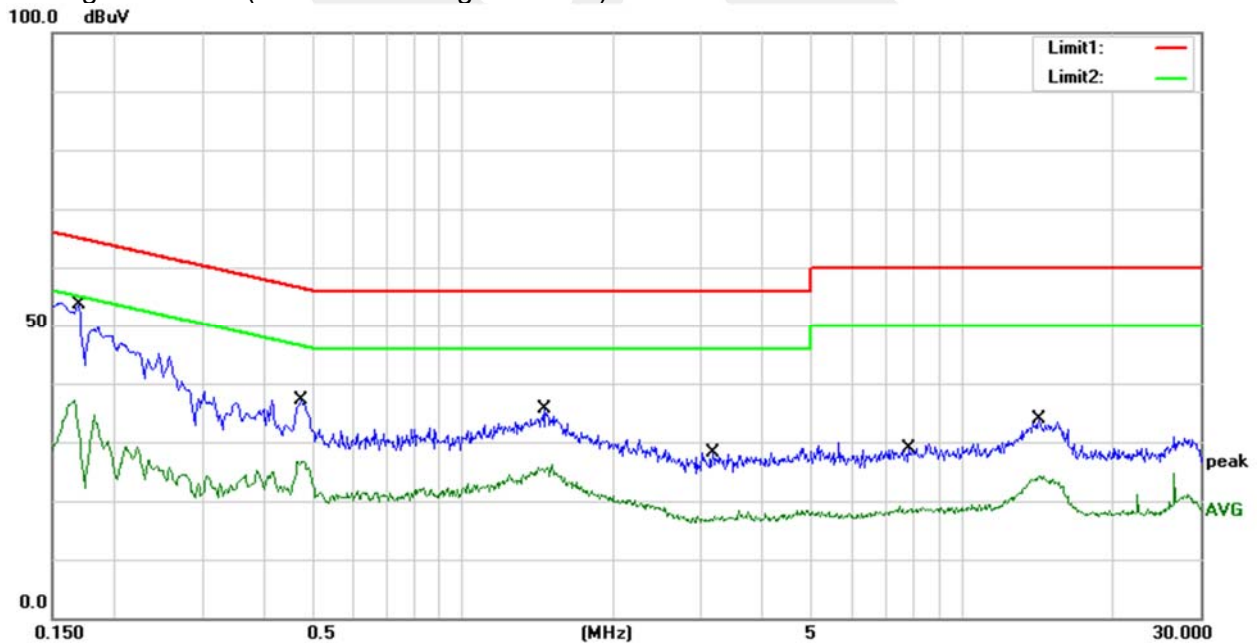



### 3.2 RADIATED EMISSION MEASUREMENT

#### 3.2.1 RADIATED EMISSION LIMITS

20dBc in any 100 kHz bandwidth outside the operating frequency band. In case the emission fall within the restricted band specified on Part 15.249 and the Part 15.209(a), RSS 210 Issue 9 and RSS-Gen limit in the table below has to be followed.

Frequencies (MHz)	Field Strength (micorvolts/meter)	Measurement Distance (meters)
0.009~0.490	2400/F(KHz)	300
0.490~1.705	24000/F(KHz)	30
1.705~30.0	30	30
30~88	100	3
88~216	150	3
216~960	200	3
960~1000	500	3
Above 1000	Other:74.0 dB(μV)/m (Peak) 54.0 dB(μV)/m (Average)	3

Field strength limit of frequency 9k~30MHz for ISED

Frequencies (KHz)	Magnetic field strength (H-Field) (μA/m)	Measurement Distance (meters)
9 - 490 <sup>Note 1</sup>	6.37/F (F in kHz)	300
490 - 1705	63.7/F (F in kHz)	30
1.705 - 30	0.08	30

Note 1: The emission limits for the ranges 9-90 kHz and 110-490 kHz are based on measurements employing a linear average detector.

Frequency of Emission (MHz)	Field Strength of fundamental (millivolts /meter)	Field Strength of Harmonics (microvolts/meter)
900~928	50	500
2400~2483.5	50	500
5725~5875	50	500
24000~242500	250	2500

Notes:

- (1) Emissions radiated outside of the specified frequency bands, except for harmonics, shall be attenuated by at least 50 dB below the level of the fundamental or to the general radiated emission limits in Section 15.209, whichever is the lesser attenuation.

Spectrum Parameter	Setting
Detector	Peak/AV
Attenuation	Auto
Start Frequency	1000 MHz
Stop Frequency	10th carrier harmonic
RB (emission in restricted band)	>20BW
VB (emission in restricted band)	=3xRB

Receiver Parameter	Setting
Attenuation	Auto
Start ~ Stop Frequency	9kHz~90kHz / RB 200Hz for PK & AV
	90kHz~110kHz / RB 200Hz for QP
	110kHz~490kHz / RB 200Hz for PK & AV
	490kHz~30MHz / RB 9kHz for QP
	30MHz~1000MHz / RB 120kHz for QP

### 3.2.2 TEST PROCEDURE

- a. The measuring distance of 3m shall be used for measurements. The EUT was placed on the top of rotating table 0.8 meter above the ground at a 3 meter semi-anechoic chamber. The table was rotated 360 degrees to determine the position of the highest radiation(Below 1GHz)
- b. The measuring distance of 3m shall used for measurements. The EUT was placed on the top of a rotating table 1.5 meter above the ground at a 3 meter semi-anechoic chamber. The table was rotated 360 degrees to determine the position of the highest radiation(Above 1GHz)
- c. The height of the test antenna shall vary between 1m to 4m.Both horizontal and vertical polarization Of the antenna are set to make the measurement.
- d. The initial step in collecting radiated emission data is a receive peak detector mode. Pre-scanning the measurement frequency range. Significant peaks are then marked and then Quasi Peak detector mode re-measured.
- e. All readings are peak unless otherwise stated QP in column of Note. Peak denoted that the Peak reading compliance with the QP limits and then QP Mode measurement didn't perform (Below 1GHz)
- f. All readings are Peak mode value unless otherwise stated AVG in column of Note. If the Peak mode measured value compliance with the Peak limits and lower than AVG Limits, the EUT shall be deemed to meet Peak & AVG limits and then only Peak mode was measured, but AVG mode didn't perform.(Above 1GHz)
- g. For the actual test configuration, please refer to the related Item –EUT Test Photos.

Note: Both horizontal and vertical antenna polarities were tested and performed pretest to three orthogonal axis. The worst case emissions were reported.

### 3.2.3 DEVIATION FROM TEST STANDARD

No deviation

### 3.2.4 TEST SETUP

#### (A) Radiated Emission Test-Up Frequency Below 30MHz

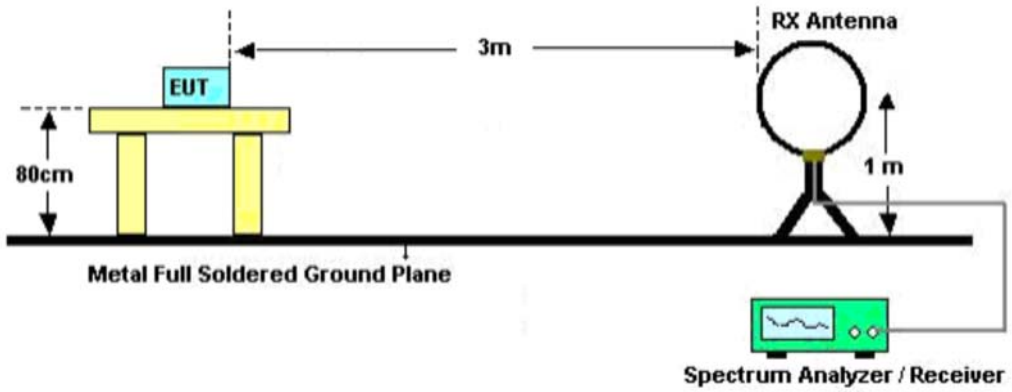

#### (B) Radiated Emission Test-Up Frequency 30MHz~1GHz

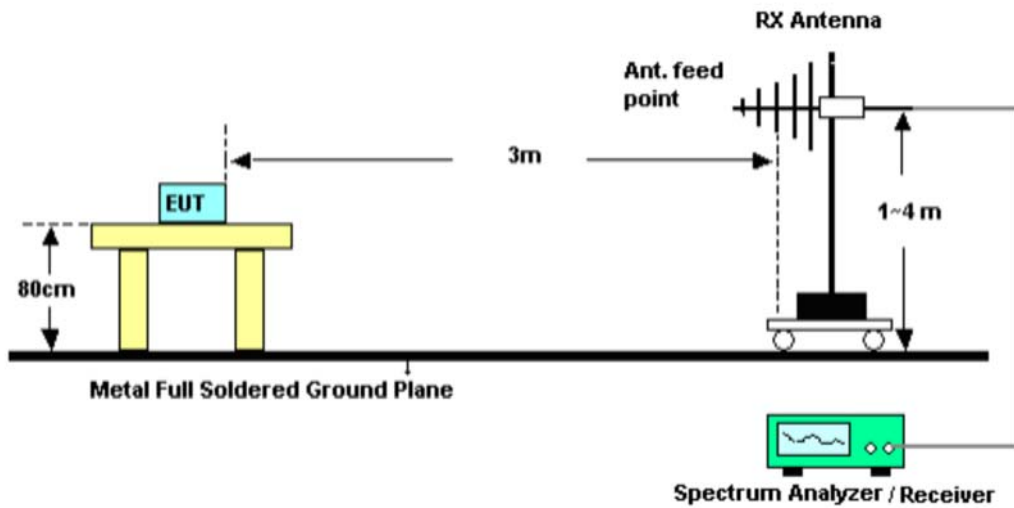

#### (C) Radiated Emission Test-Up Frequency Above 1GHz

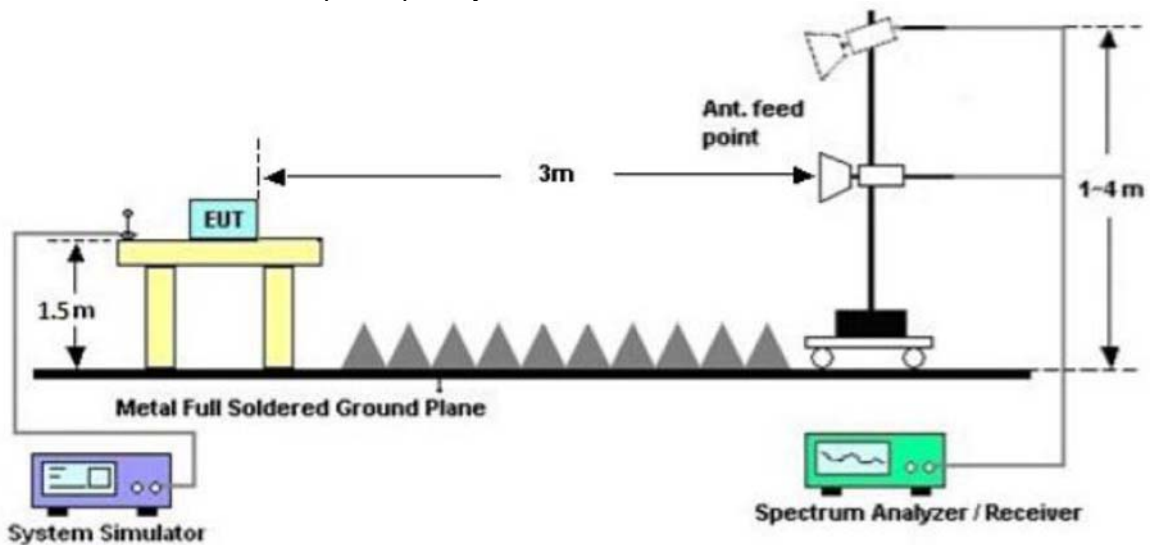



### 3.2.5 FIELD STRENGTH CALCULATION

The field strength is calculated by adding the Antenna Factor and Cable Factor and subtracting the Amplifier Gain and Duty Cycle Correction Factor (if any) from the measured reading. The basic equation with a sample calculation is as follows:

Margin=PL-PK L or AL- AV L; Margin only shown the worst case.

Where

PR = Peak Reading

AR = Average Reading

PL = Peak Level

AL = Average Level

AF = Antenna Factor

PK L = Peak Limit

AV L = AV Limit

For example

Frequency	PR	AR	AF	PL	AL	PK L	AV L	Margin
(MHz)	(dB $\mu$ V/m)	(dB $\mu$ V/m)	(dB)	(dB $\mu$ V/m)	(dB $\mu$ V/m)	(dB $\mu$ V/m)	(dB $\mu$ V/m)	(dB)
2178	40.23	30.31	9.83	50.06	40.14	74.00	54.00	-13.86





### 3.2.6 EUT OPERATING CONDITIONS

The EUT tested system was configured as the statements of 2.4 Unless otherwise a special operating condition is specified in the follows during the testing.

Below 30 MHz

Temperature:	23.1(C)	Relative Humidity:	52%RH
Test Voltage:	DC 3.7V	Polarization:	---
Test Mode:	TX Mode		

Freq. (MHz)	Reading (dBuV/m)	Limit (dBuV/m)	Margin (dB)	State P/F
--	--	--	--	PASS
--	--	--	--	PASS

**NOTE:**

The amplitude of spurious emissions which are attenuated by more than 20dB below the permissible value has no need to be reported.

Distance extrapolation factor =  $40 \log(\text{specific distance}/\text{test distance})(\text{dB})$ ;

Limit line = specific limits(dBuv) + distance extrapolation factor.

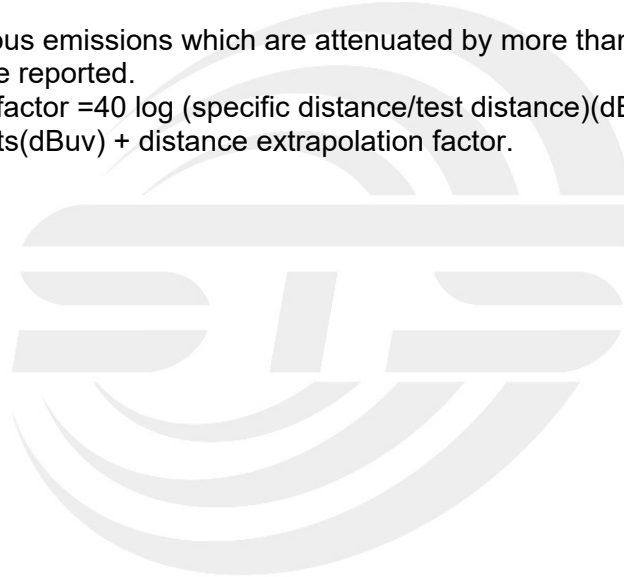



Between 30MHz – 1000 MHz Radiation Spurious

Temperature:	23.1(C)	Relative Humidity:	52%RH
Test Voltage:	DC 3.7V	Phase:	Horizontal
Test Mode:	Mode 1/2/3(Mode 1 worst mode)		

No.	Frequency (MHz)	Reading (dBuV)	Correct Factor(dB)	Result (dBuV)	Limit (dBuV)	Margin (dB)	Remark
1	48.4300	55.31	-22.44	32.87	40.00	-7.13	QP
2	98.8700	50.93	-20.31	30.62	43.50	-12.88	QP
3	320.0300	48.14	-14.00	34.14	46.00	-11.86	QP
4	510.1500	40.94	-7.94	33.00	46.00	-13.00	QP
5	910.7600	33.77	-0.17	33.60	46.00	-12.40	QP
6	983.5100	30.57	2.46	33.03	54.00	-20.97	QP

Remark:

1. Margin = Result (Result =Reading + Factor )–Limit

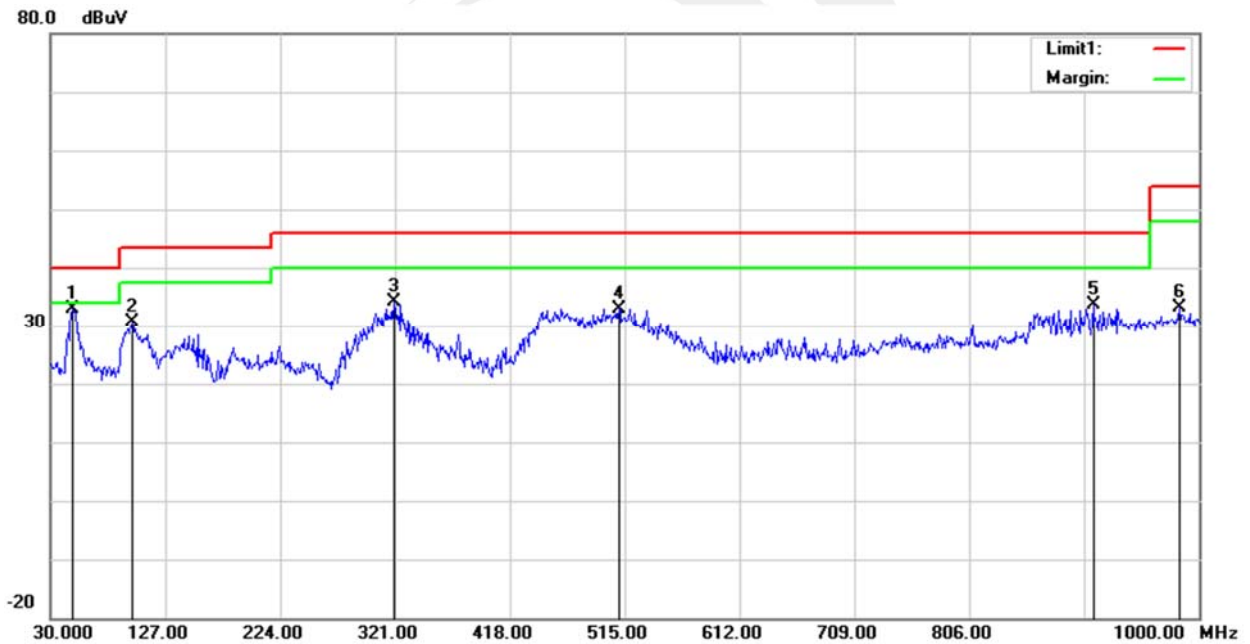



Temperature:	23.1(C)	Relative Humidity:	52%RH
Test Voltage:	DC 3.7V	Phase:	Vertical
Test Mode:	Mode 1/2/3(Mode 1 worst mode)		

No.	Frequency (MHz)	Reading (dBuV)	Correct Factor(dB)	Result (dBuV)	Limit (dBuV)	Margin (dB)	Remark
1	103.7200	46.76	-19.73	27.03	43.50	-16.47	QP
2	303.5400	44.25	-14.69	29.56	46.00	-16.44	QP
3	532.4600	37.62	-7.31	30.31	46.00	-15.69	QP
4	645.9500	35.17	-4.87	30.30	46.00	-15.70	QP
5	800.1800	32.79	-2.05	30.74	46.00	-15.26	QP
6	975.7500	31.46	2.38	33.84	54.00	-20.16	QP

Remark:

1. Margin = Result (Result =Reading + Factor)–Limit







Above 1G Radiation Spurious

Low channel Horizontal											
Frequency (MHz)	Peak Reading (dBuV/m)	Factor (dB)	Peak Level (dBuV/m)	Duty Factor (dB)	Average Level (dBuV/m)	PK Limit (dBuV/m)	AV Limit (dBuV/m)	PK Over Limit (dB)	AV Over Limit (dB)	Min Margin(dB)	ANT
1062.5	39.77	-1.74	38.03	0.00	38.03	74.00	54.00	-35.97	-15.97	-15.97	Horizontal
2131	38.74	4.31	43.05	0.00	43.05	74.00	54.00	-30.95	-10.95	-10.95	Horizontal
4810	54.69	-6.94	47.75	0.00	47.75	74.00	54.00	-26.25	-6.25	-6.25	Horizontal
7104.5	46.17	2.75	48.92	0.00	48.92	74.00	54.00	-25.08	-5.08	-5.08	Horizontal
10982	40.25	10.08	50.33	0.00	50.33	74.00	54.00	-23.67	-3.67	-3.67	Horizontal
14229.75	39.91	11.37	51.28	0.00	51.28	74.00	54.00	-22.72	-2.72	-2.72	Horizontal
Low channel Vertical											
Frequency (MHz)	Peak Reading (dBuV/m)	Factor (dB)	Peak Level (dBuV/m)	Duty Factor (dB)	Average Level (dBuV/m)	PK Limit (dBuV/m)	AV Limit (dBuV/m)	PK Over Limit (dB)	AV Over Limit (dB)	Margin(dB)	ANT
1599.5	39.79	-0.49	39.30	0.00	39.30	74.00	54.00	-34.70	-14.70	-14.70	Vertical
2319	38.96	4.51	43.47	0.00	43.47	74.00	54.00	-30.53	-10.53	-10.53	Vertical
4261	57.85	-8.98	48.87	0.00	48.87	74.00	54.00	-25.13	-5.13	-5.13	Vertical
7280.5	47.69	3.26	50.95	0.00	50.95	74.00	54.00	-23.05	-3.05	-3.05	Vertical
11026	40.96	10.08	51.04	0.00	51.04	74.00	54.00	-22.96	-2.96	-2.96	Vertical
14606.5	41.51	11.14	52.65	0.00	52.65	74.00	54.00	-21.35	-1.35	-1.35	Vertical
Mid channel Horizontal											
Frequency (MHz)	Peak Reading (dBuV/m)	Factor (dB)	Peak Level (dBuV/m)	Duty Factor (dB)	Average Level (dBuV/m)	PK Limit (dBuV/m)	AV Limit (dBuV/m)	PK Over Limit (dB)	AV Over Limit (dB)	Min Margin(dB)	ANT
1336.5	42.85	-0.83	42.02	0.00	42.02	74.00	54.00	-31.98	-11.98	-11.98	Horizontal
2345.5	44.48	4.4	48.88	0.00	48.88	74.00	54.00	-25.12	-5.12	-5.12	Horizontal
4258	58.49	-8.99	49.50	0.00	49.50	74.00	54.00	-24.50	-4.50	-4.50	Horizontal
7090.75	48.29	2.66	50.95	0.00	50.95	74.00	54.00	-23.05	-3.05	-3.05	Horizontal
14238	39.77	11.31	51.08	0.00	51.08	74.00	54.00	-22.92	-2.92	-2.92	Horizontal
17977.999	40.64	11.46	52.10	0.00	52.10	74.00	54.00	-21.90	-1.90	-1.90	Horizontal
Mid channel Vertical											
Frequency (MHz)	Peak Reading (dBuV/m)	Factor (dB)	Peak Level (dBuV/m)	Duty Factor (dB)	Average Level (dBuV/m)	PK Limit (dBuV/m)	AV Limit (dBuV/m)	PK Over Limit (dB)	AV Over Limit (dB)	Margin(dB)	ANT
1597.5	43.18	-0.5	42.68	0.00	42.68	74.00	54.00	-31.32	-11.32	-11.32	Vertical
2661.5	40.83	4.51	45.34	0.00	45.34	74.00	54.00	-28.66	-8.66	-8.66	Vertical
4262	56.41	-8.98	47.43	0.00	47.43	74.00	54.00	-26.57	-6.57	-6.57	Vertical
5760	52.55	-3.94	48.61	0.00	48.61	74.00	54.00	-25.39	-5.39	-5.39	Vertical
10946.25	40.45	9.81	50.26	0.00	50.26	74.00	54.00	-23.74	-3.74	-3.74	Vertical
17477.501	40.99	10.7	51.69	0.00	51.69	74.00	54.00	-22.31	-2.31	-2.31	Vertical





High channel Horizontal											
Frequency (MHz)	Peak Reading (dBuV/m)	Factor (dB)	Peak Level (dBuV/m)	Duty Factor (dB)	Average Level (dBuV/m)	PK Limit (dBuV/m)	AV Limit (dBuV/m)	PK Over Limit (dB)	AV Over Limit (dB)	Min Margin(dB)	ANT
1491.5	39.76	-0.56	39.20	0.00	39.20	74.00	54.00	-34.80	-14.80	-14.80	Horizontal
2123.5	41.95	4.19	46.14	0.00	46.14	74.00	54.00	-27.86	-7.86	-7.86	Horizontal
4956	55.92	-6.39	49.53	0.00	49.53	74.00	54.00	-24.47	-4.47	-4.47	Horizontal
8034	46.78	4.01	50.79	0.00	50.79	74.00	54.00	-23.21	-3.21	-3.21	Horizontal
11009.5	41.54	10.17	51.71	0.00	51.71	74.00	54.00	-22.29	-2.29	-2.29	Horizontal
14215.999	41.31	11.48	52.79	0.00	52.79	74.00	54.00	-21.21	-1.21	-1.21	Horizontal
High channel Vertical											
Frequency (MHz)	Peak Reading (dBuV/m)	Factor (dB)	Peak Level (dBuV/m)	Duty Factor (dB)	Average Level (dBuV/m)	PK Limit (dBuV/m)	AV Limit (dBuV/m)	PK Over Limit (dB)	AV Over Limit (dB)	Margin(dB)	ANT
1063.5	40.90	-1.74	39.16	0.00	39.16	74.00	54.00	-34.84	-14.84	-14.84	Vertical
2132.5	40.95	4.34	45.29	0.00	45.29	74.00	54.00	-28.71	-8.71	-8.71	Vertical
4956	56.12	-6.39	49.73	0.00	49.73	74.00	54.00	-24.27	-4.27	-4.27	Vertical
8603.25	46.42	4.08	50.50	0.00	50.50	74.00	54.00	-23.50	-3.50	-3.50	Vertical
11468.75	40.16	9.89	50.05	0.00	50.05	74.00	54.00	-23.95	-3.95	-3.95	Vertical
14232.5	41.23	11.35	52.58	0.00	52.58	74.00	54.00	-21.42	-1.42	-1.42	Vertical





Duty cycle

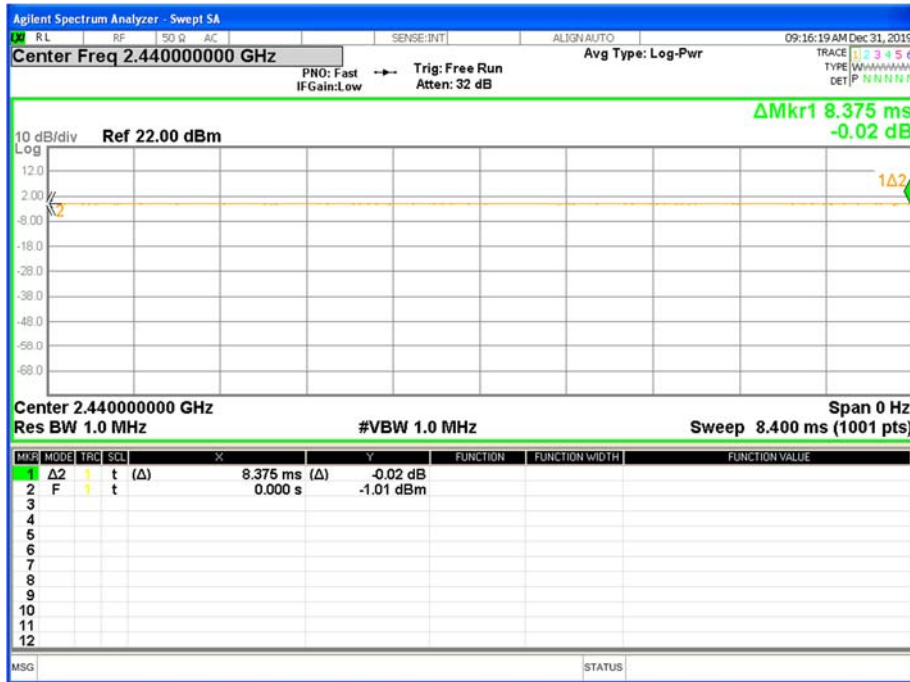

Ton	Tp	Duty cycle(%)	Duty factor(dB)
8.375	8.375	100.00%	0.00

Note: Duty Factor=20\*LOG10(1/(Ton/Tp))



(Radiation Band edge)

Low channel  
Horizontal

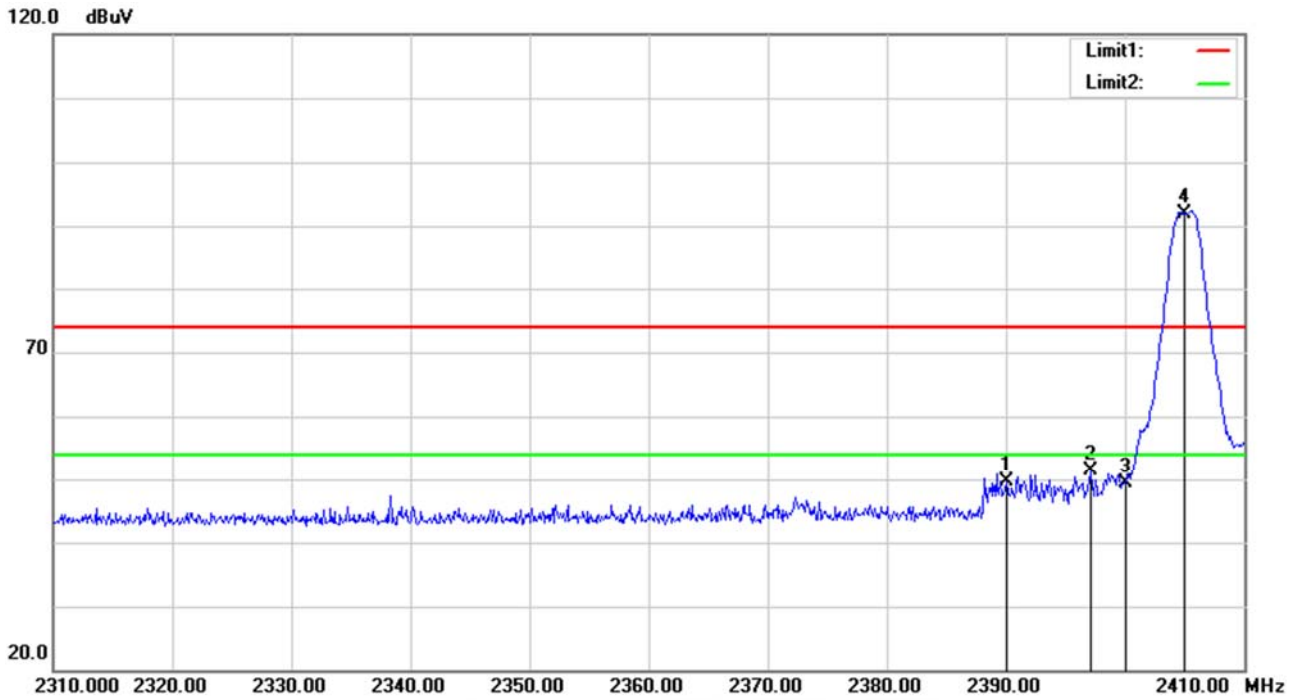

No.	Frequency (MHz)	Reading (dBuV)	Correct Factor(dB)	Result (dBuV)	Limit (dBuV)	Margin (dB)	Remark
1	2390.000	45.38	4.34	49.72	74.00	-24.28	peak
2	2397.100	46.89	4.45	51.34	74.00	-22.66	peak
3	2400.000	44.87	4.49	49.36	74.00	-24.64	peak

Fundamental Frequency

No.	Frequency (MHz)	Reading (dBuV)	Correct Factor (dB/m)	Duty cycle Factor (dB/m)	Result (dBuV/m)	Limit (dBuV/m)	Margin (dB)	Remark
4	2405.000	87.37	4.50	-	91.87	114.00	-22.13	peak
5	2405.000	87.37	4.50	0	91.87	94.00	-2.13	AV



Vertical

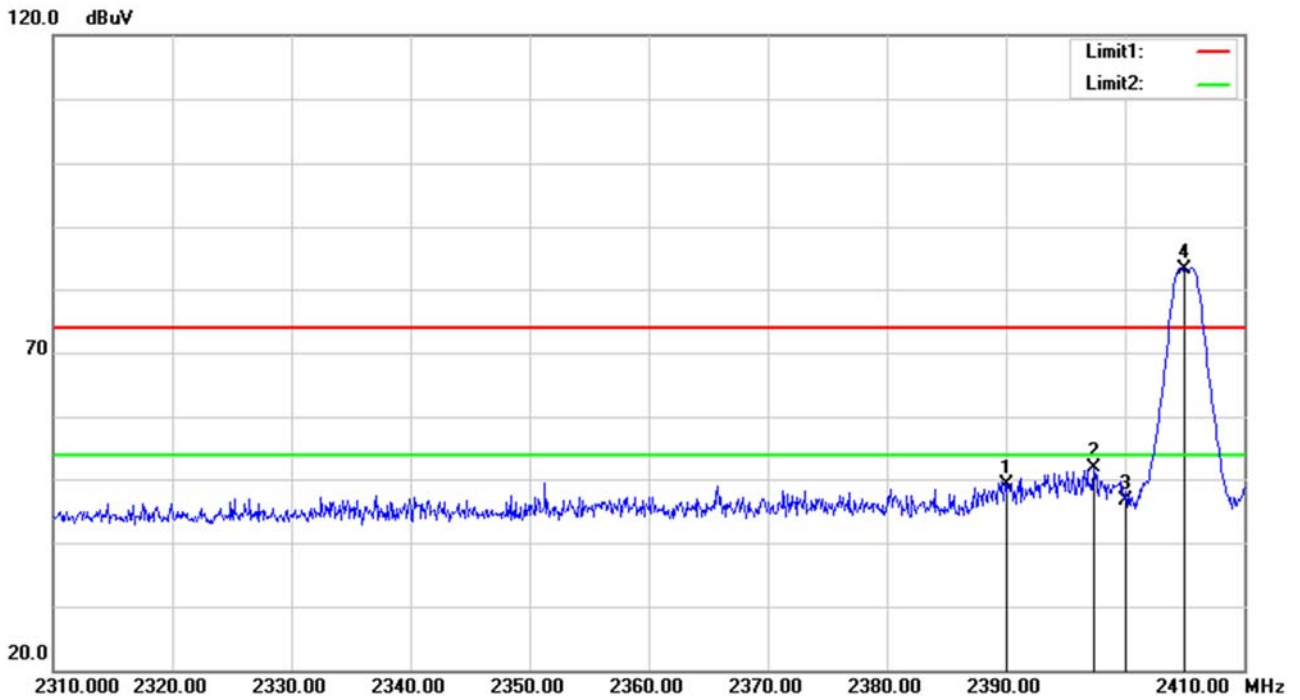

No.	Frequency (MHz)	Reading (dBuV)	Correct Factor(dB)	Result (dBuV)	Limit (dBuV)	Margin (dB)	Remark
1	2390.000	44.89	4.34	49.23	74.00	-24.77	peak
2	2397.400	47.45	4.45	51.90	74.00	-22.10	peak
3	2400.000	42.21	4.49	46.70	74.00	-27.30	peak

Fundamental Frequency

No.	Frequency (MHz)	Reading (dBuV)	Correct Factor (dB/m)	Duty cycle Factor (dB/m)	Result (dBuV/m)	Limit (dBuV/m)	Margin (dB)	Remark
4	2405.000	78.53	4.50	-	83.03	114.00	-30.97	peak
5	2405.000	78.53	4.50	0	83.03	94.00	-10.97	AV

**Mid channel**  
Horizontal

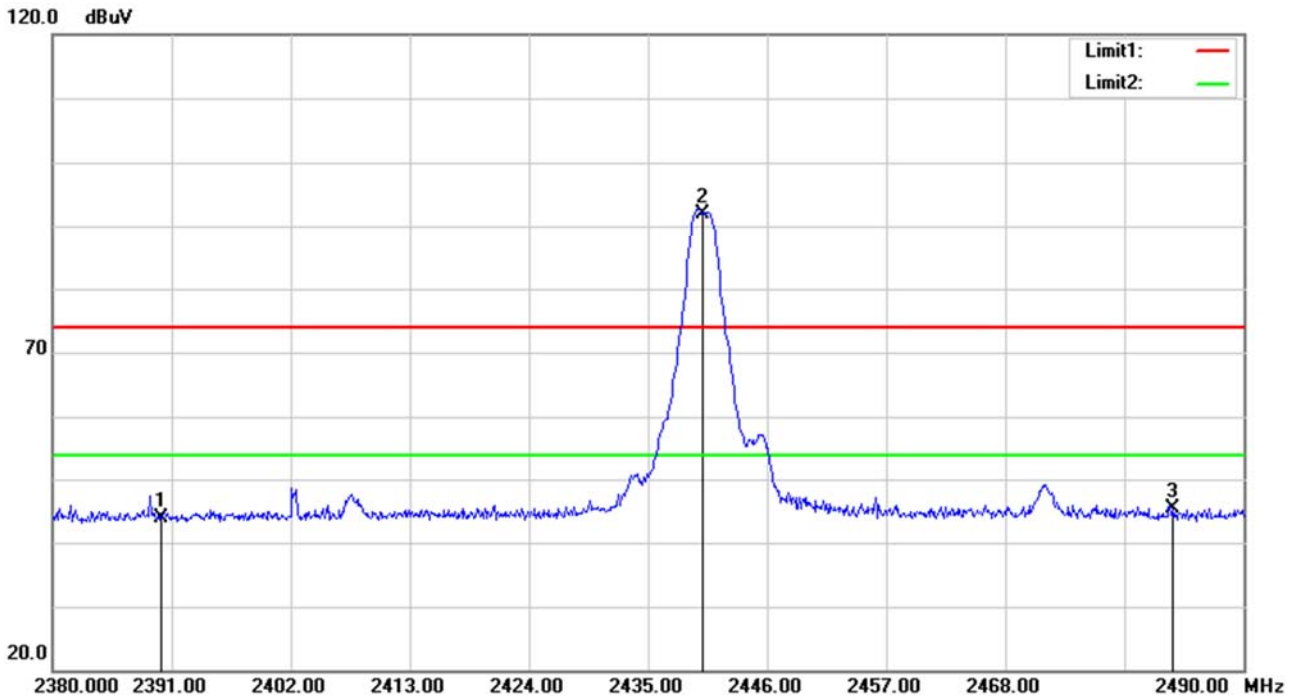

No.	Frequency (MHz)	Reading (dBuV)	Correct Factor(dB)	Result (dBuV)	Limit (dBuV)	Margin (dB)	Remark
1	2390.000	39.55	4.34	43.89	74.00	-30.11	peak
3	2483.500	40.69	4.60	45.29	74.00	-28.71	peak

Fundamental Frequency

No.	Frequency (MHz)	Reading (dBuV)	Correct Factor (dB/m)	Duty cycle Factor (dB/m)	Result (dBuV/m)	Limit (dBuV/m)	Margin (dB)	Remark
2	2440.000	87.27	4.52	-	91.79	114.00	-22.21	peak
4	2440.000	87.27	4.52	0	91.79	94.00	-2.21	AV



Vertical

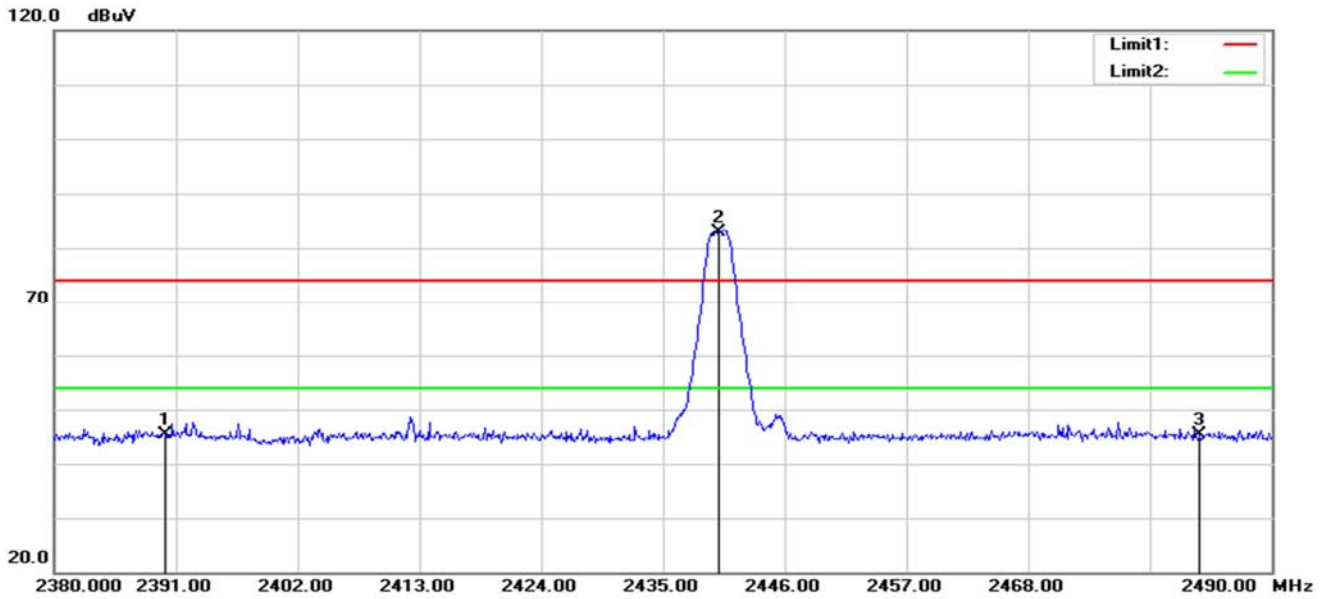

No.	Frequency (MHz)	Reading (dBuV)	Correct Factor(dB)	Result (dBuV)	Limit (dBuV)	Margin (dB)	Remark
1	2390.000	41.03	4.34	45.37	74.00	-28.63	peak
3	2483.500	40.84	4.60	45.44	74.00	-28.56	peak

Fundamental Frequency

No.	Frequency (MHz)	Reading (dBuV)	Correct Factor (dB/m)	Duty cycle Factor (dB/m)	Result (dBuV/m)	Limit (dBuV/m)	Margin (dB)	Remark
2	2440.000	78.24	4.52	-	82.76	114.00	-31.24	peak
4	2440.000	78.24	4.52	0	82.76	94.00	-11.24	AV

### High channel Horizontal

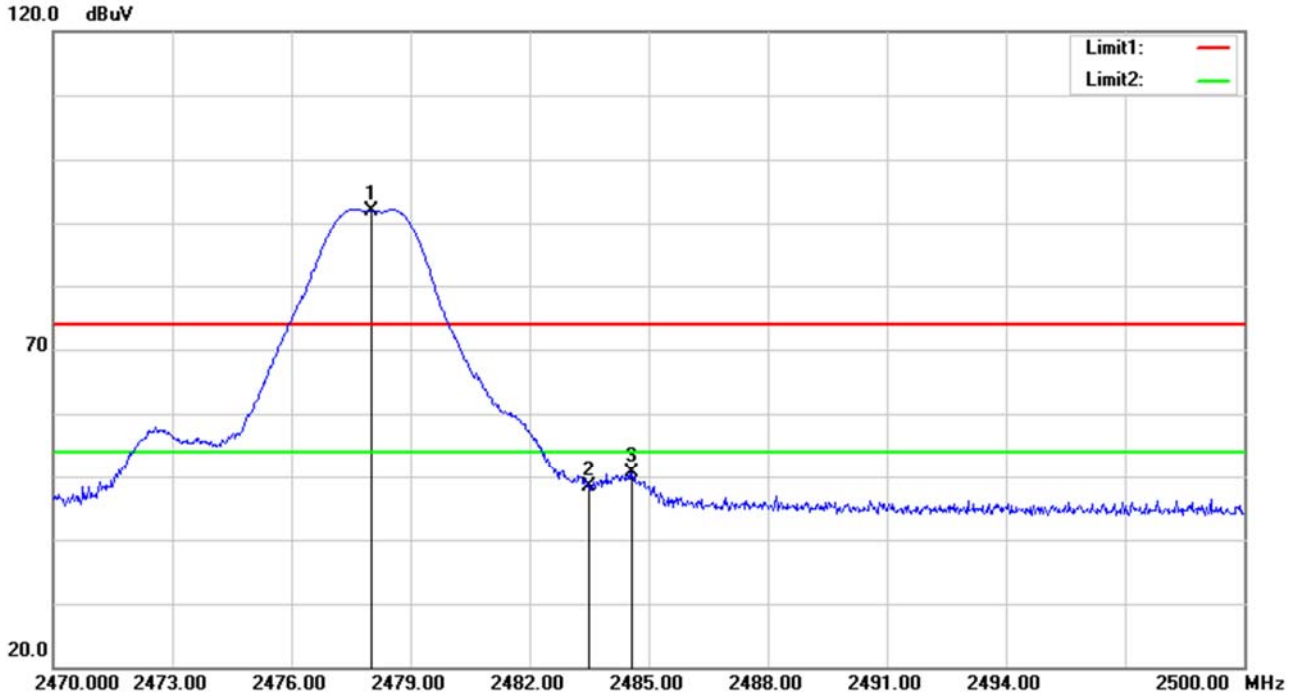

No.	Frequency (MHz)	Reading (dBuV)	Correct Factor(dB)	Result (dBuV)	Limit (dBuV)	Margin (dB)	Remark
2	2483.500	43.75	4.60	48.35	74.00	-25.65	peak
3	2484.580	45.94	4.61	50.55	74.00	-23.45	peak

### Fundamental Frequency

No.	Frequency (MHz)	Reading (dBuV)	Correct Factor (dB/m)	Duty cycle Factor (dB/m)	Result (dBuV/m)	Limit (dBuV/m)	Margin (dB)	Remark
1	2478.000	87.23	4.60	-	91.83	114.00	-22.17	peak
4	2478.000	87.23	4.60	0	91.83	94.00	-2.17	AV



Vertical

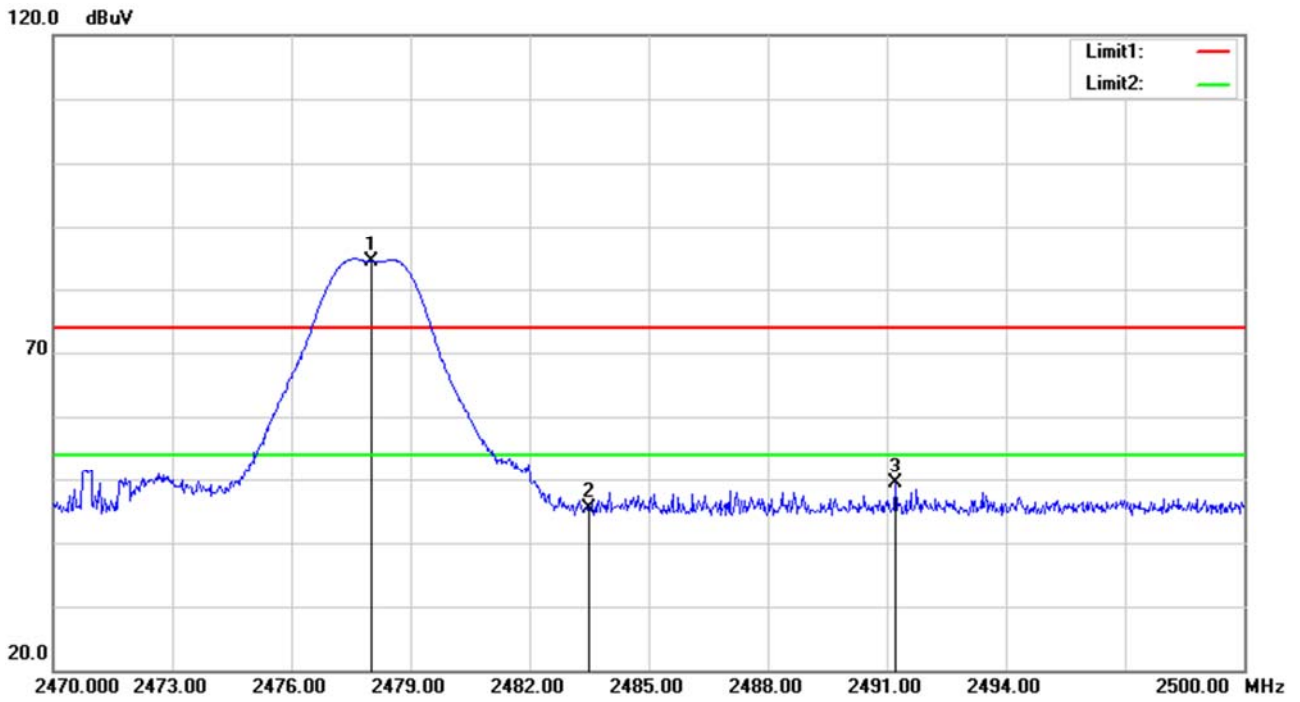

No.	Frequency (MHz)	Reading (dBuV)	Correct Factor(dB)	Result (dBuV)	Limit (dBuV)	Margin (dB)	Remark
2	2483.500	40.90	4.60	45.50	74.00	-28.50	peak
3	2491.210	44.83	4.63	49.46	74.00	-24.54	peak

Fundamental Frequency

No.	Frequency (MHz)	Reading (dBuV)	Correct Factor (dB/m)	Duty cycle Factor (dB/m)	Result (dBuV/m)	Limit (dBuV/m)	Margin (dB)	Remark
1	2478.000	79.79	4.60	-	84.39	114.00	-29.61	peak
4	2478.000	79.79	4.60	0	84.39	94.00	-9.61	AV



#### 4. BANDWIDTH TEST

##### 4.1 TEST PROCEDURE

- a. The EUT was directly connected to the spectrum analyzer and antenna output port as show in the block diagram below,
- b. Spectrum Setting :  $RBW= 30\text{KHz}$ ,  $VBW \geq RBW$ , Sweep time = Auto.

##### 4.2 TEST SETUP



##### 4.3 EUT OPERATION CONDITIONS

TX mode.





4.4 TEST RESULTS

Temperature:	25 °C	Relative Humidity:	50%
Test Voltage:	DC 3.7V		

Test Channel	Frequency	20 dB Bandwidth	99% Bandwidth
	(MHz)	(MHz)	(MHz)
CH01	2405	2.434	2.1504
CH39	2440	2.404	2.1256
CH74	2478	2.431	2.1465

Low Channel

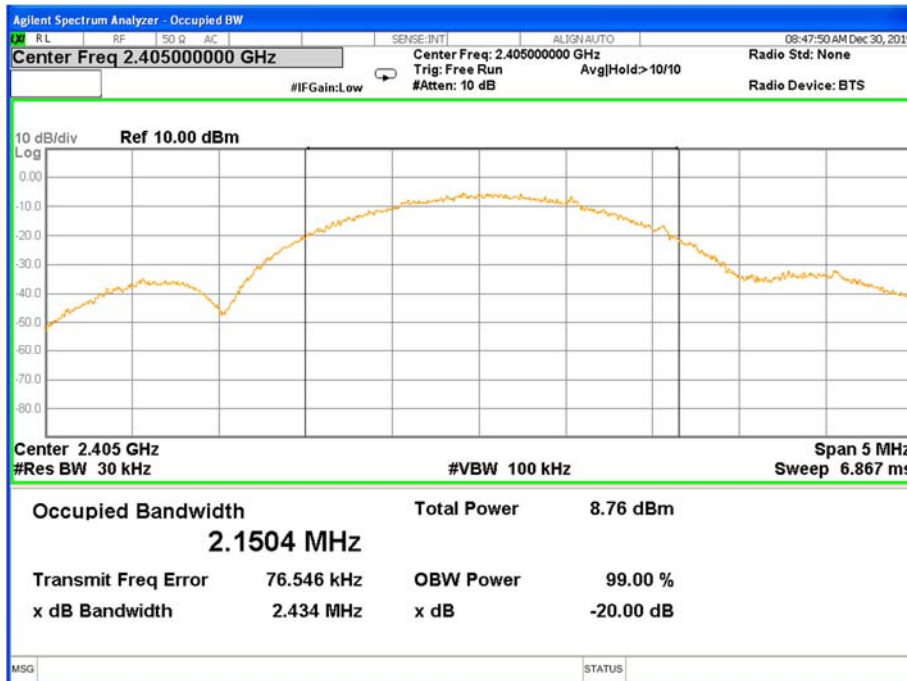



### Mid Channel

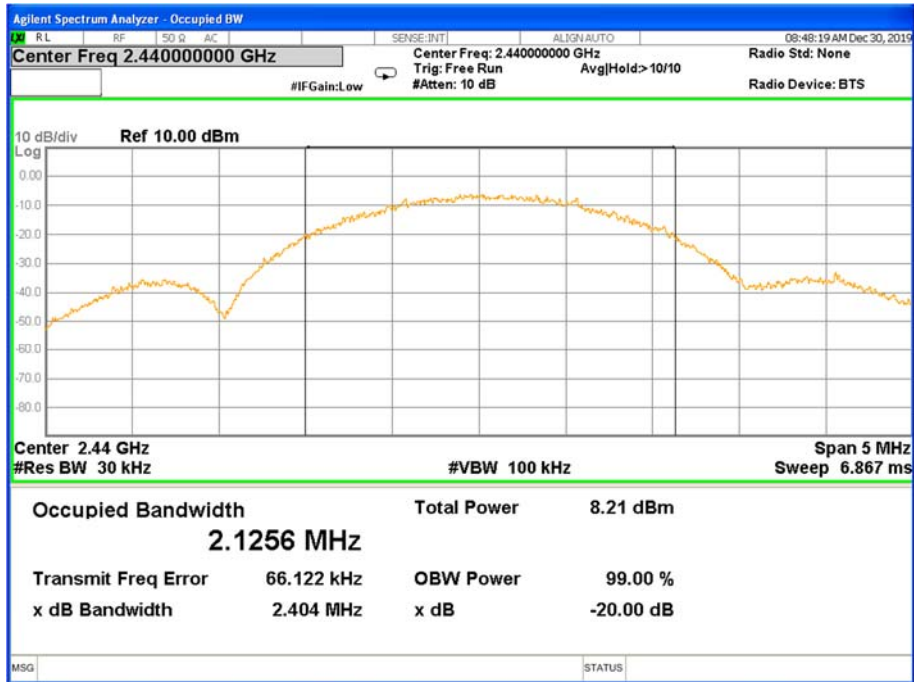

### High Channel

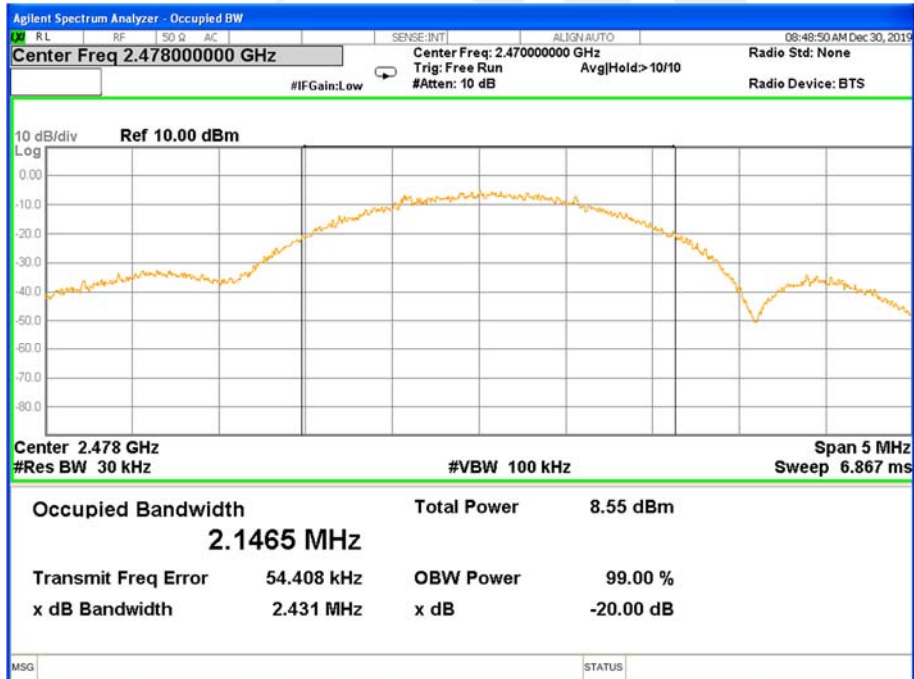



## 5. ANTENNA REQUIREMENT

### 5.1 STANDARD REQUIREMENT

According to the FCC Part 15 Paragraph 15.203 and RSS-Gen, an intentional radiator shall be designed to ensure that no antenna other than that furnished by the responsible party shall be used with the device.

### 5.2 EUT ANTENNA

The EUT antenna is PCB Antenna. It conforms to the standard requirements.



