

Amber Helm Development L.C.

92723 Michigan Hwy-152
Sister Lakes, MI 49047

EMC Test Report

#0901300FX

Issued 02/01/2010

Regarding the FCC 15.247 testing of



Gateway Unit

Model Number: 31570002

Grantee FCC Registration Number: 0018833475 Grantee Code: X3S

Equipment Product Code: AMPT-GW Equipment Class: K1D

Category: 2.4 GHz Intentional Radiating Transceiver Device

Judgments: FCC Article 15.247, FCC Part 15 Class B – Compliant



NVLAP LAB CODE 2001294

Prepared for:

Bob Porter
AMPT LLC
4850 Innovation Dr.
Ft. Collins, Co. 80525

Test Date(s): 11/12/09-01/30/2010

Report prepared by:



David J. Miller, NCE

Report reviewed by



Gordon Helm, NCE

Data recorded by:



Gordon Helm, NCE
Test Engineer, AHD

Table of Contents

Statements concerning this report.....	3
FCC Required user statements:.....	4
Summary of Results.....	5
Changes Made to Achieve Compliance:.....	6
EUT Descriptions.....	7
Description:.....	7
Specifications:.....	7
Input Power: USB.....	7
Outputs Signals: USB, 2.4 GHz.....	7
EUT Block Diagram:.....	10
EUT Pictures.....	11
Equipment Test Setup:.....	13
Support Equipment & Cabling.....	13
Setup Pictures.....	14
Measurement Report.....	20
Standards Applied to Test.....	20
Equipment Configuration.....	20
Test Methodology.....	20
Line Conducted:.....	20
Radiated:.....	20
Variance from Test Procedure:.....	21
Test Data.....	22
Line Conducted:.....	22
Radiated Spurious Emissions.....	24
Radiated Receive Local Oscillator Emissions.....	26
Radiated Transmit Emissions.....	26
15.247 Specific Transmit Emissions, Hopping Frequency Mode.....	28
RF Exposure Calculation:.....	32
Measurement Facilities & Equipment.....	33
Test Site.....	33
Measurement Equipment Used.....	33
Test Site 2.....	33
Environment.....	33
APPENDIX A.....	34
Measurement Procedures.....	34
Line Conducted.....	34
Radiated.....	35
Cable Loss.....	36
Antenna Factors.....	38
AHD Accreditation.....	39
NARTE Seal.....	40

Statements concerning this report**NVLAP Accreditation: NVLAP Lab Code 200129-0**

The scope of AHD accreditation are the test methods of:

IEC/CISPR 22:	Limits and methods measurement of radio disturbance characteristics of information technology equipment.
FCC Method – 47 CFT Part 15:	Digital Devices.
AS/NZS 3548:	Electromagnetic Interference – Limits and Methods of Measurement of Information Technology Equipment.
IEC61000-4-2 and Amend.1:	Electrostatic Discharge Immunity
IEC61000-4-5:	Surge Immunity

Test Data:

This test report contains data included in the scope of NVLAP accreditation.

Subcontracted Testing:

This report contains data recorded at the University of Michigan Radiation Laboratory. The University of Michigan test facility is located at 8501 Beck Road, Belleville, Michigan 48111. This test facility has been fully described and accepted by the FCC and Industry Canada. This facility was utilized to measure emissions occurring at frequencies greater than 6GHz.

Test Traceability:

The calibration of all measuring and test equipment and the measured data using this equipment are traceable to the National Institute for Standards and Technology (NIST).

Limitations on results:

The test results contained in this report relate only to the Item(s) tested. Any electrical or mechanical modification made to the test item subsequent to the test date shall invalidate the data presented in this report. Any electrical or mechanical modification made to the test item subsequent to this test date shall require an evaluation to verify continued compliance.

Limitations on copying:

This report shall not be reproduced, except in full, without the written approval of AHD.

Limitations of the report:

This report shall not be used to claim product endorsement by NVLAP, FCC, or any agency of the US Government.

Statement of Test Results Uncertainty:

Following the guidelines of NAMAS publication NIS81 and NIST Technical Note 1297, the Measurement Uncertainty at a 95% confidence level is determined to be: +/- 1.4 dB

Retention of Records:

For equipment verified to comply with FCC regulations, the manufacturer is obliged to retain this report with the product records for ten years following the manufacture of the equipment that was tested.

For equipment verified to comply with RSS-210, the manufacturer is obliged to retain this report with the product records for as long as the model is being marketed in Canada.

FCC Required user statements:**Applies to:** [Class B Digital Device or Peripheral].

For products satisfying the FCC Part 15 Class B requirements the following are to be satisfied:

1. The following statement is required to be labeled on the product or, if the device is too small, in the user's manual:

This device complies with part 15 of the FCC Rules. Operation is subject to the following two conditions: (1) This device may not cause harmful interference, and (2) this device must accept any interference received, including interference that may cause undesired operation.

2. A statement is required to be placed in the User's Manual shall caution the user that changes or modifications not expressly approved by the party responsible for compliance could void the user's authority to operate the equipment.
3. The User's Manual shall include this or similar statement:

NOTE: This equipment has been tested and found to comply with the limits for a Class B digital device, pursuant to part 15 of the FCC Rules. These limits are designed to provide reasonable protection against harmful interference in a residential installation. This equipment generates, uses, and can radiate radio frequency energy and, if not installed and used in accordance with the instruction manual, may cause harmful interference to radio communications. However, there is no guarantee that interference will not occur in a particular installation. If this equipment does cause harmful interference to radio or television reception, which can be determined by turning the equipment off and on, the user is encouraged to try to correct the interference by one or more of the following measures:

- *Reorient or relocate the receiving antenna.*
- *Increase the separation between the equipment and receiver.*
- *Connect the equipment into an outlet on a circuit different from that to which the receiver is connected.*
- *Consult the dealer or an experienced radio/TV technician for help.*

4. For products certified using the Declaration of Conformity approach,
 - a. The FCC conformity LOGO is to be placed on the Class B Digital Device.

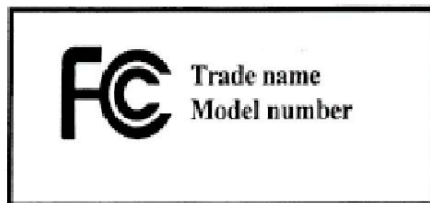

- b. The FCC requires a Compliance Information statement (Declaration of Conformity) to accompany each product to the end user.

Summary of Results

1. The device model number 31570002 was tested for compliance with FCC Regulations, Part 15, SubPart C.
2. The system tested is compliant to the requirement of CFR 47, FCC Part 15, SubPart C for operation in the 2400-2483.5 MHz frequency band, article 15.247, as a frequency hopping system.
3. These tests were performed at AHD EMC Laboratory following the procedures outlined in ANSI C63.4.
4. The test results apply to model 31570002.
5. The equipment under test was received on 11/12/09 and this test series commenced on 11/12/09.
6. In 120VAC 60Hz operation, the conducted emission level nearest the limit during normal tx / rx operation occurred at 26.72 MHz. The signal was measured to be 12.97dB below the Class B Quasi-Peak limit and 8.93 dB below the Class B Average limit when measuring neutral to ground.
7. The spurious radiated emission level nearest the limit during normal tx / rx operation occurred at 62.25 MHz vertically polarized. This signal was measured to be 2.52 dB below the Class B Quasi-peak limit.
8. The radiated fundamental Local Oscillator emission level nearest the limit occurred at 2448 MHz. The signal was measured to be 26.1 dB below the FCC class B average limit.
9. The radiated harmonic Local Oscillator emission level nearest the limit occurred 4823.9 MHz. This signal was measured to be 26.1 dB below the FCC class B average limit.
10. All radiated fundamental signals were measured within the FCC 15.247 band limits of 2400 MHz and 2483 MHz.
11. A maximized data rate mode was used to measure transmit power in peak detector mode, therefore a correction factor corresponding to the normal operational duty cycle is required to correlate peak measurements to the limits expressed in terms of average detection. The width of a transmitted packet was measured to be 20.79 mSec. The time period from one packet to the next was measured to be 285.3 mSec. Over the FCC 15.35c specified 100 mSec period, the packet width represents a 20.79% duty cycle, or -13.6 dB correction factor.
12. The fundamental transmission level was measured using radiated emissions measurements. The formula used to convert measured electrical field strength to conducted power was $EIRP = ((D^2 * E^2) / 30G)$. The distance used in the measurement was 3 Meters (D=3) and the antenna gain factor used in calculations was one (G=1). While the manufacturer specified antenna gain is specified at 2.15dB, a gain factor of one is used in the calculations to ensure worst case calculations.
13. The radiated fundamental transmit emission level nearest the limit occurred at 2475 MHz. The field strength level of the fundamental was observed to be 123.86 mW below the

average limit of 125mW. The EUT was positioned on the FLAT orientation and the receive antenna oriented in the Horizontal polarization.

14. The radiated second harmonic transmit emission level nearest the limit occurred at 4883.94 MHz. The field strength level was observed to be 1.9 dB below the average limit of 54dBuV/m (500uV/m). The EUT was positioned on the SIDE orientation and the receive antenna oriented in the Horizontal polarization.
15. The radiated upper level harmonic transmit emission level nearest the limit occurred at 9894 MHz. The field strength level was observed to be 8.5 dB below the average limit of 54 dBuV/m (500uV/m).
16. Radiated band edge measurements nearest the limit occurred at 2484 MHz. The field strength level was observed to be 9.2 dB below the average limit of 54 dBuV/m.
17. As a frequency hopping device, the system operates on 26 channels, with one channel left blank. This meets the minimum 15 channel requirement of 15.247.a.1
18. As a frequency hopping device, the system operates with each channel occupying a 675 KHz 20 dB bandwidth, and each channel separated by 2.55 MHz. The carrier separation is 1.88 MHz wider than the 20dB bandwidth, satisfying the 15.247.a.1 requirement for channel separation.
19. The algorithm used for selecting hopping frequencies is pseudo random in nature, using the base channel as an algorithmic “seed” frequency. The algorithm ensures equal distribution among available channels during operation.
20. The time occupied per any channel in any 10.4 second cycle (0.4 seconds*26 channels) is by design at most 31.18 mSec, satisfying the maximum 15.247.a.iii limit of 400 mSec on any channel per cycle.
21. The antenna used in the system is integrated on the system PCB, and has a specified maximum gain of 2.15dB.
22. In frequency hopping mode, the peak in band 100KHz BW signal strength is 107.86 dBuV or 12.63 dBm EIRP. The strongest 100 KHz in band signal strengths adjacent to the in band peak signals are more than 20dB below the peak, satisfying the 15.247.d requirements.
23. Under normal operating conditions, the general public is not exposed to this device. However, even under conditions of exposure to this device at a distance of 2.5 cm, the expected exposure is .015 mw/cm², or 0.985mw/cm² under the FCC 1.1310 general population limit of 1 mw/cm².
24. With regard to SAR evaluation, the worst case EIRP of 1.14 mW is 23.35 mW below the FCC KDB 447948 recommended SAR evaluation limit of 24.5 mW at 2.45 GHz.

Changes Made to Achieve Compliance:

1. Transmit level reduced to a setting of “P -1”

EUT Descriptions**Model:** Gateway**Model number:** 31570002**Serial/ID No:** 3409K001757/AHD53**Antenna:** 2.15 dB gain, Integrated on PCB**PCB:** 33070004D**Description:**

This device is a frequency hopping radio controlled Solar Array Management System Gateway. The device utilizes 25 frequency hopping channels, with each channel separated by 10 of the possible 256 channels. The exact subset of 25 hopping channels utilized depends on the initial channel selected during initialization. The frequency usage, channel selection, and hopping algorithms are described in Exhibit B.

Specifications:**Input Power:** USB**Outputs Signals:** USB, 2.4 GHz**Input Signals:** USB, 2.4 GHz Receive

Channel Frequencies:

Ch	Freq, MHz	Example: Ch 0 Hopping freq:
0	2410.000	0 2410.000
1	2410.253	10 2412.527
2	2410.505	20 2415.054
3	2410.758	30 2417.581
4	2411.011	40 2420.107
5	2411.263	50 2422.634
6	2411.516	60 2425.161
7	2411.769	70 2427.688
8	2412.021	80 2430.215
9	2412.274	90 2432.742
10	2412.527	100 2435.269
11	2412.780	110 2437.795
12	2413.032	120 2440.322
13	2413.285	130 2442.849
14	2413.538	140 2445.376
15	2413.790	150 2447.903
16	2414.043	160 2450.430
17	2414.296	170 2452.957
18	2414.548	180 2455.483
19	2414.801	190 2458.010
20	2415.054	200 2460.537
21	2415.306	210 2463.064
22	2415.559	220 2465.591
23	2415.812	230 2468.118
24	2416.064	240 2470.645
25	2416.317	
26	2416.570	
27	2416.823	
28	2417.075	
29	2417.328	
30	2417.581	
31	2417.833	
32	2418.086	
33	2418.339	
34	2418.591	
35	2418.844	
36	2419.097	
37	2419.349	
38	2419.602	
39	2419.855	
40	2420.107	
41	2420.360	
42	2420.613	
43	2420.865	
44	2421.118	
45	2421.371	
46	2421.624	
47	2421.876	

FCC Article 15.247, FCC Part 15 Class B for AMPT Gateway

Ch Freq	Ch Freq	Ch Freq	Ch Freq	Ch Freq
48 2422.129	97 2434.510	146 2446.892	195 2459.274	244 2471.655
49 2422.382	98 2434.763	147 2447.145	196 2459.526	245 2471.908
50 2422.634	99 2435.016	148 2447.397	197 2459.779	246 2472.161
51 2422.887	100 2435.269	149 2447.650	198 2460.032	247 2472.413
52 2423.140	101 2435.521	150 2447.903	199 2460.284	248 2472.666
53 2423.392	102 2435.774	151 2448.156	200 2460.537	249 2472.919
54 2423.645	103 2436.027	152 2448.408	201 2460.790	250 2473.171
55 2423.898	104 2436.279	153 2448.661	202 2461.042	251 2473.424
56 2424.150	105 2436.532	154 2448.914	203 2461.295	252 2473.677
57 2424.403	106 2436.785	155 2449.166	204 2461.548	253 2473.929
58 2424.656	107 2437.037	156 2449.419	205 2461.801	254 2474.182
59 2424.908	108 2437.290	157 2449.672	206 2462.053	255 2474.435
60 2425.161	109 2437.543	158 2449.924	207 2462.306	
61 2425.414	110 2437.795	159 2450.177	208 2462.559	
62 2425.667	111 2438.048	160 2450.430	209 2462.811	
63 2425.919	112 2438.301	161 2450.682	210 2463.064	
64 2426.172	113 2438.553	162 2450.935	211 2463.317	
65 2426.425	114 2438.806	163 2451.188	212 2463.569	
66 2426.677	115 2439.059	164 2451.440	213 2463.822	
67 2426.930	116 2439.312	165 2451.693	214 2464.075	
68 2427.183	117 2439.564	166 2451.946	215 2464.327	
69 2427.435	118 2439.817	167 2452.198	216 2464.580	
70 2427.688	119 2440.070	168 2452.451	217 2464.833	
71 2427.941	120 2440.322	169 2452.704	218 2465.085	
72 2428.193	121 2440.575	170 2452.957	219 2465.338	
73 2428.446	122 2440.828	171 2453.209	220 2465.591	
74 2428.699	123 2441.080	172 2453.462	221 2465.844	
75 2428.951	124 2441.333	173 2453.715	222 2466.096	
76 2429.204	125 2441.586	174 2453.967	223 2466.349	
77 2429.457	126 2441.838	175 2454.220	224 2466.602	
78 2429.709	127 2442.091	176 2454.473	225 2466.854	
79 2429.962	128 2442.344	177 2454.725	226 2467.107	
80 2430.215	129 2442.596	178 2454.978	227 2467.360	
81 2430.468	130 2442.849	179 2455.231	228 2467.612	
82 2430.720	131 2443.102	180 2455.483	229 2467.865	
83 2430.973	132 2443.354	181 2455.736	230 2468.118	
84 2431.226	133 2443.607	182 2455.989	231 2468.370	
85 2431.478	134 2443.860	183 2456.241	232 2468.623	
86 2431.731	135 2444.113	184 2456.494	233 2468.876	
87 2431.984	136 2444.365	185 2456.747	234 2469.128	
88 2432.236	137 2444.618	186 2457.000	235 2469.381	
89 2432.489	138 2444.871	187 2457.252	236 2469.634	
90 2432.742	139 2445.123	188 2457.505	237 2469.886	
91 2432.994	140 2445.376	189 2457.758	238 2470.139	
92 2433.247	141 2445.629	190 2458.010	239 2470.392	
93 2433.500	142 2445.881	191 2458.263	240 2470.645	
94 2433.752	143 2446.134	192 2458.516	241 2470.897	
95 2434.005	144 2446.387	193 2458.768	242 2471.150	
96 2434.258	145 2446.639	194 2459.021	243 2471.403	

EUT Block Diagram:

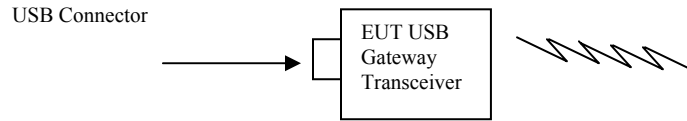

EUT Pictures

Exterior Overall View	Page 14
Interior PCB Top View	Page 14
Interior PCB Bottom View	Page 15
Gateway Control Application	Page 15

Exterior View



Interior PCB Top View



Interior PCB Bottom View



Gateway Control Application View



Equipment Test Setup:

Support Equipment & Cabling

Setup Diagram Legend	Description	Model	Serial No. / Part No.	EMC Consideration
A	EUT Gateway Transceiver	31570002	AHD53	2.4 GHZ TRANSCEIVER
B	Application Controlling Laptop	IBM T43	1871-FUI	1 Meter Shielded
C	Laptop Power Supply	IBM 08k8208		
D	USB Cable			1 Meter
E	USB Cable			3 Meter
F	USB 4 port Hub	Belkin FSU304	CZ811782 84	
G	USB Mouse			

Block Diagram

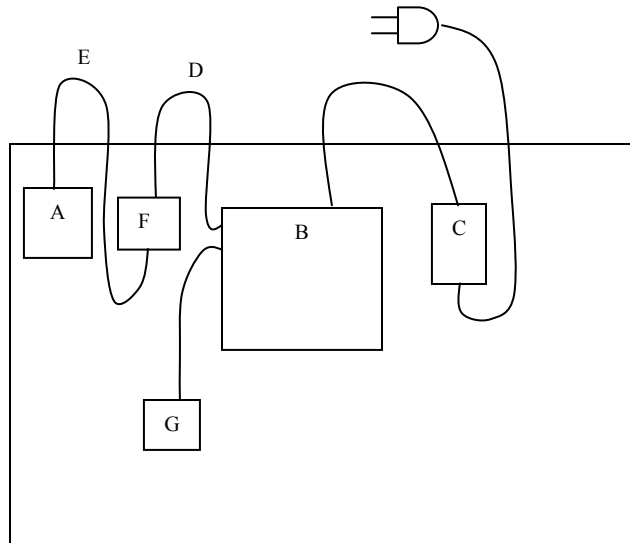

Setup Pictures

Spurious Radiated Prescreen Setup	Page 17
Conducted Setup Front View	Page 18
Conducted Setup Rear View	Page 18
Spurious and Rx Radiated Setup Front View	Page 19
Spurious and Rx Radiated Setup Rear View	Page 19
Transmit Setup Flat Orientation	Page 20
Transmit Setup End Orientation	Page 20
Transmit Setup Side Orientation	Page 21
Transmit 10% Duty Cycle Scope Plot A	Page 21
Transmit 10% Duty Cycle Scope Plot B	Page 22

Spurious Radiated Prescreen Setup



Conducted Setup Front View



Conducted Setup Rear View



Spurious and Rx Radiated Setup Front View



Spurious and Rx Radiated Setup Rear View



Transmit Setup Flat Orientation



Transmit Setup End Orientation



Transmit Setup Side Orientation



Transmit Duty Cycle Pulse Width Plot

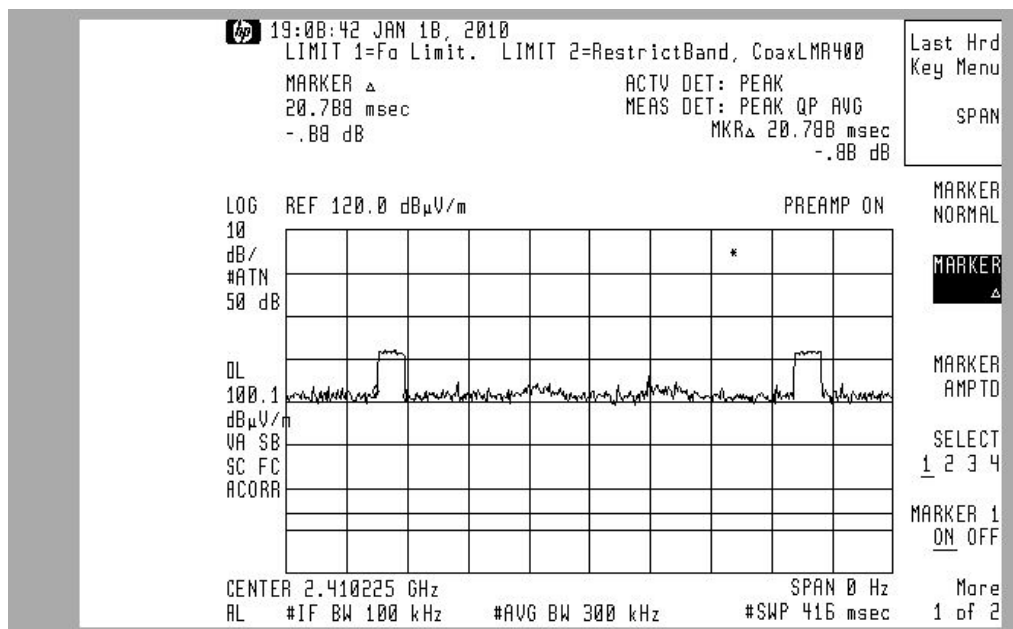

Transmit Duty Cycle Period Plot

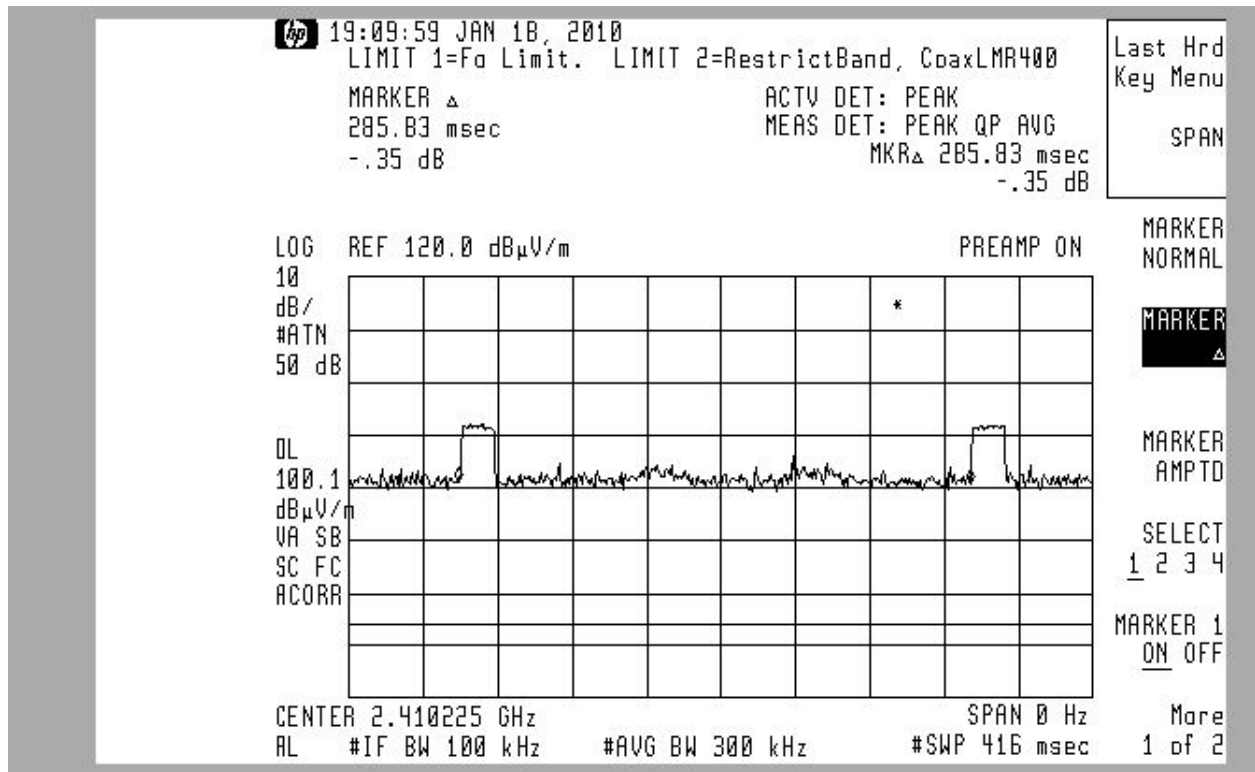

Measurement Report

Standards Applied to Test

ANSI C63.4 – 2003
CFR47 FCC Part 15, SubPart B, Class B limits
AHD test procedures TP0101-01, TP0102-01

Equipment Configuration

For the testing, the placement of the EUT and the support equipment was selected to –

- Be a representation of a configuration typical of user installation, and
- Comply with the minimum system configuration of ANSI C63.4.

Test Methodology

Line Conducted:

Detailed Line Conducted test methodology is located in Appendix A.

The cable losses of the coax used in line conducted testing are charted in this appendix.

Radiated:

Spurious, transmit, and receive radiated testing was performed at a 3 meter open field test site, and completed according to the procedures in FCC 15, SubPart B with supporting instructions from ANSI C63.4. Please reference Appendix A for further details on Test Methodology.

A scan of the EUT was made in a shielded room to study the emission profile of this EUT. This scan indicated low level spurious emissions from the unit.

The suspect spurious signals recorded in the shielded room prescan for each module were then measured at the 3-meter open area test site. Spurious radiated emissions were measured in normal operating tx/rx mode.

For transmit signal strength measurement, the EUT was configured to operate in a maximized packet rate mode and measurements were taken at the mid-range fundamental and second harmonic frequencies (2442, 4884 MHz) in two polarizations (horizontal, vertical) and three orientations (flat, side, and end.) This was done to determine the EUT orientation that maximized emissions.

Once positioned in the maximized orientation, the EUT was tested at the low (2410 MHz), mid range (2442 MHz), and high (2474 MHz) operating frequencies within the EUT's operating range.

Because the EUT has an integrated antenna, measurements were converted from electrical field strength (dBuV/m) to EIRP (watts and dBm) using the formula $P = (ED)^2/30$.

Because maximized packet rate mode was utilized to test the device, zero span (time scale) measurements were taken to determine PWM duty cycle attenuation over a 100 mSec period. Based on these findings, the maximized data rate mode (peak) measurements were then compensated -13.6 dB to provide average transmit signal strength for comparison to FCC limits.

Upper level harmonics were measured to 10 harmonics (24 GHz) over the total range of operating frequencies. Worst case signal conditions were recorded at harmonics of the low, mid, and high operating range frequencies.

For receive operation, the EUT was exercised at the low (2410 MHz), medium (2442 MHz), and high (2474 MHz) frequencies within the EUT's operating range, as well as 5 harmonics (12 GHz) of those frequencies. Signals that were below ambient noise levels were evaluated at a closer (1 Meter) distance to the EUT and scaled at 20dB/decade for comparison to 3 meter FCC limits. Worst case signal conditions were recorded.

Tx and Rx Harmonics over 6 GHz were measured at the U of M test Site (see Appendix.)

In addition, a variety of 15.247 specific bandedge measurements were taken, in both frequency hopping and digital modulation modes.

The EUT under test was placed per ANSI C63.4

The EUT was exercised as follows:

1. Device was powered via external power supply
2. The device was activated via Gateway Transceiver Control Application
3. Receive Operation was evidenced by Local Oscillator signal
4. Transmit Operation was evidenced by Transmit Signal

The pictures, in the preceding pages, show the position of the equipment and cabling that produced the maximum signal level.

Variance from Test Procedure:

None

**PHASE to Ground Measurement.
Class B Plot of Peak Values**

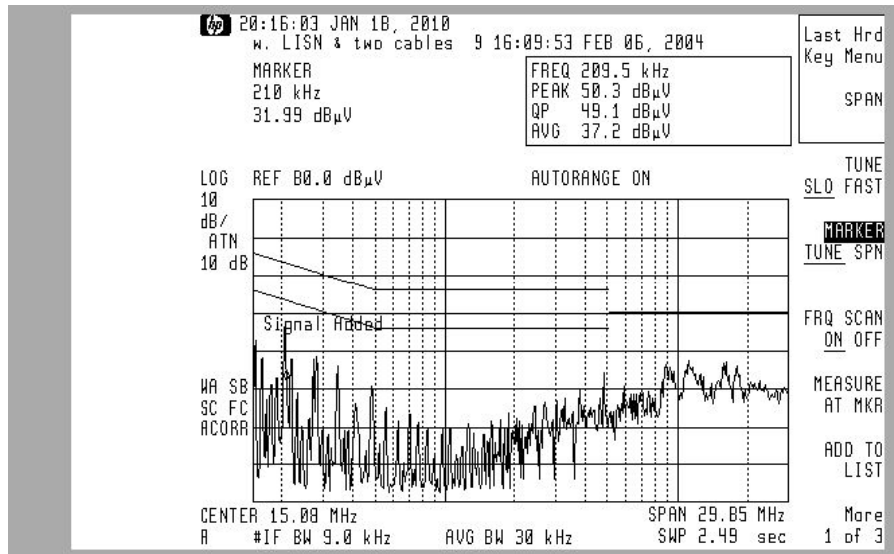

**PHASE to Ground Conducted
Class B Tabulated Measurements**

Frequency MHz	dBuV Reading		FCC / EN55022 dBuV Class B Limit		dB Margin	
	QP	Avg	QP	Avg	QP	Avg
0.21	49.00	37.00	63.21	53.21	14.21	16.21
0.28	39.00	31.00	60.82	50.82	21.82	19.82
0.40	37.00	33.00	57.85	47.85	20.85	14.85
16.00	37.00	32.00	60.00	50.00	23.00	18.00
21.34	41.21	35.35	60.00	50.00	18.79	14.65
26.72	46.67	40.76	60.00	50.00	13.33	9.24

Radiated Spurious Emissions

**Vertically Polarized 3 Meter
Class B Graph of Spurious Quasi-Peak Measurements**

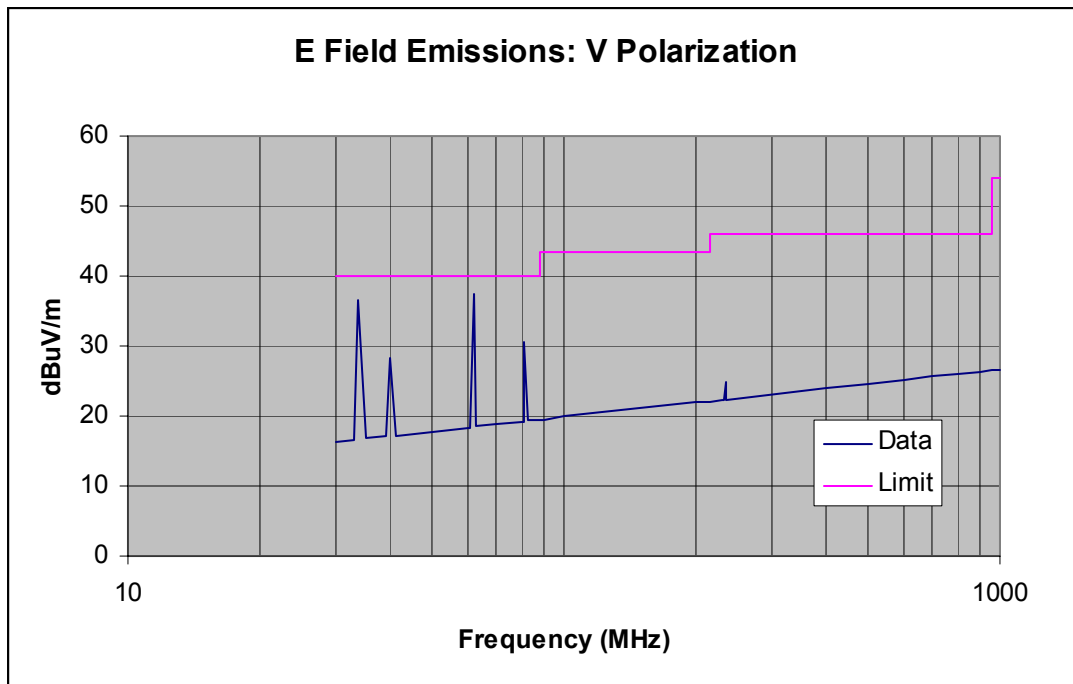

Class B Tabulated Spurious Quasi-Peak Measurements

Frequency	Corrected Quasipeak Measurement	Turntable Azimuth	Antenna Height	FCC Class B Limit	Margin
MHz	dBuV/m	deg	Mtr	dBuV/m	dBuV/m
33.72	36.46	190	1.0	40.00	3.54
40.06	28.42	0	1.0	40.00	11.58
62.25	37.48	150	1.0	40.00	2.52
81.37	30.63	300	1.0	40.00	9.37
234.62	24.82	270	1.0	46.00	21.18
240.03	23.95	120	1.0	46.00	22.05

**Horizontally Polarized
Class B Graph of Spurious Quasi-Peak Measurements**

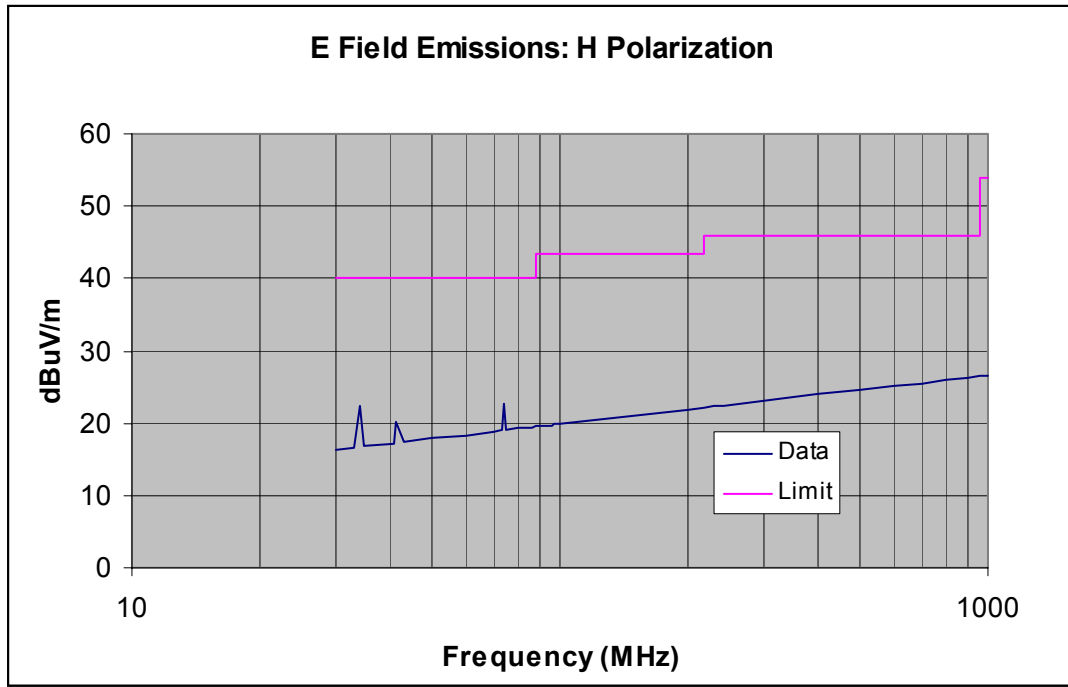

Class B Tabulated Quasi-Peak Measurements

Frequency	Corrected Quasipeak Measurement	Turntable Azimuth	Antenna Height	FCC Class B Limit	Margin
MHz	dBuV/m	deg	Mtr	dBuV/m	dBuV/m
34.00	22.50	260	4.0	40.00	17.50
41.47	20.30	0	4.0	40.00	19.70
73.77	22.57	160	4.0	40.00	17.43
85.41	18.84	180	4.0	40.00	21.16
240.03	19.84	60	2.0	46.00	26.16

Radiated Receive Local Oscillator Emissions**Class B Tabulated Average Measurements**

Frequency	Corrected Average Measurement	Turntable Azimuth	Antenna Height	FCC Class B Limit	Margin Class B
MHz	dBuV/m	deg	Mtr	dBuV/m	dBuV/m
2411.97	17.73	-	1.00	54.00	36.27
2448.00	27.90	-	1.00	54.00	26.10
2477.72	2.07	-	1.00	54.00	51.93
4823.90	19.55	-	1.00	54.00	34.45
4895.80	17.96	-	1.00	54.00	36.04
4957.20	18.63	-	1.00	54.00	35.37
7230.00*	34.60	-	1.00	54.00	19.40
9640.00*	38.20	-	1.00	54.00	15.80
12050.00*	38.80	-	1.00	54.00	15.20

***note: Measurements at these frequencies represent noise floor measurement, no actual signal was detected**

Radiated Transmit Emissions**Fundamental Worst Case Tabulated Measurements**

Frequency	Corrected Peak Measurement	EUT orientation	Compensated Average Measurement	V/m	EIRP	Turntable Azimuth	Antenna Height	FCC 15.247 limit	Margin Class B
MHz	dBuV/m		dBuV/m	V/m	mW	deg	Mtr	mW	dBuV/m
2410.00	108.10	h-flat	94.50	0.05	0.85	240	2.2	125.0	124.15
2442.06	108.63	v-side	95.03	0.06	0.96	150	1.2	125.0	124.04
2475.00	109.40	h-flat	95.80	0.06	1.14	30	1.2	125.0	123.86

Second Harmonic Worst Case Tabulated Measurements

Frequency	Corrected Peak Measurement	EUT orientation	Compensated Average Measurement	Turntable Azimuth	Antenna Height	FCC limit	Margin Class B
MHz	dBuV/m		dBuV/m	deg	Mtr	dBuV/m	dBuV/m
4820.00	57.40	h-flat	43.80	190	1.2	54.0	10.20
4883.94	65.70	h-side	52.10	140	1.1	54.0	1.90
4949.00	59.30	h-flat	45.70	240	1.0	54.0	8.30

Upper Harmonic Worst Case Tabulated Measurement

Frequency	Corrected Peak Measurement	Compensated Average Measurement	Antenna Height	Average FCC limit	Margin Class B
MHz	dBuV/m	dBuV/m	Mtr	dBuV/m	dBuV/m
7230.00	57.00	43.40	1.00	54.00	10.60
7326.00	54.20	40.60	1.00	54.00	13.40
7420.50	56.00	42.40	1.00	54.00	11.60
9640.00	51.10	37.50	1.00	54.00	16.50
9768.00	56.50	42.90	1.00	54.00	11.10
9894.00	59.10	45.50	1.00	54.00	8.50
12050.00	56.00	42.40	1.00	54.00	11.60
12210.00	53.00	39.40	1.00	54.00	14.60
12367.50	50.30	36.70	1.00	54.00	17.30
14460.00	46.40	32.80	1.00	54.00	21.20
14652.00	45.90	32.30	1.00	54.00	21.70
14841.00	45.50	31.90	1.00	54.00	22.10
16870.00	43.00	29.40	1.00	54.00	24.60
17094.00	38.90	25.30	1.00	54.00	28.70
17314.50	33.60	20.00	1.00	54.00	34.00
19280.00	32.30	18.70	1.00	54.00	35.30
19536.00	34.50	20.90	1.00	54.00	33.10
19788.00	34.80	21.20	1.00	54.00	32.80
21690.00	32.10	18.50	1.00	54.00	35.50
21978.00	33.60	20.00	1.00	54.00	34.00
22261.50	35.40	21.80	1.00	54.00	32.20
24100.00	33.10	19.50	1.00	54.00	34.50
24420.00	35.40	21.80	1.00	54.00	32.20
24735.00	36.60	23.00	1.00	54.00	31.00

Band Edge Tabulated Measurement

Frequency	Corrected Peak Measurement	EUT orientation	Compensated Average Measurement	Turntable Azimuth	Antenna Height	Average FCC 15.249 limit	Margin Class B
MHz	dBuV/m		dBuV/m	deg	Mtr	dBuV/m	dBuV/m
2400.00	52.43	h-flat	38.83	170.00	1.10	54.00	15.17
2484.00	58.40	h-flat	44.80	150.00	1.30	54.00	9.20

15.247 Specific Transmit Emissions, Hopping Frequency Mode

25 Channel Plot

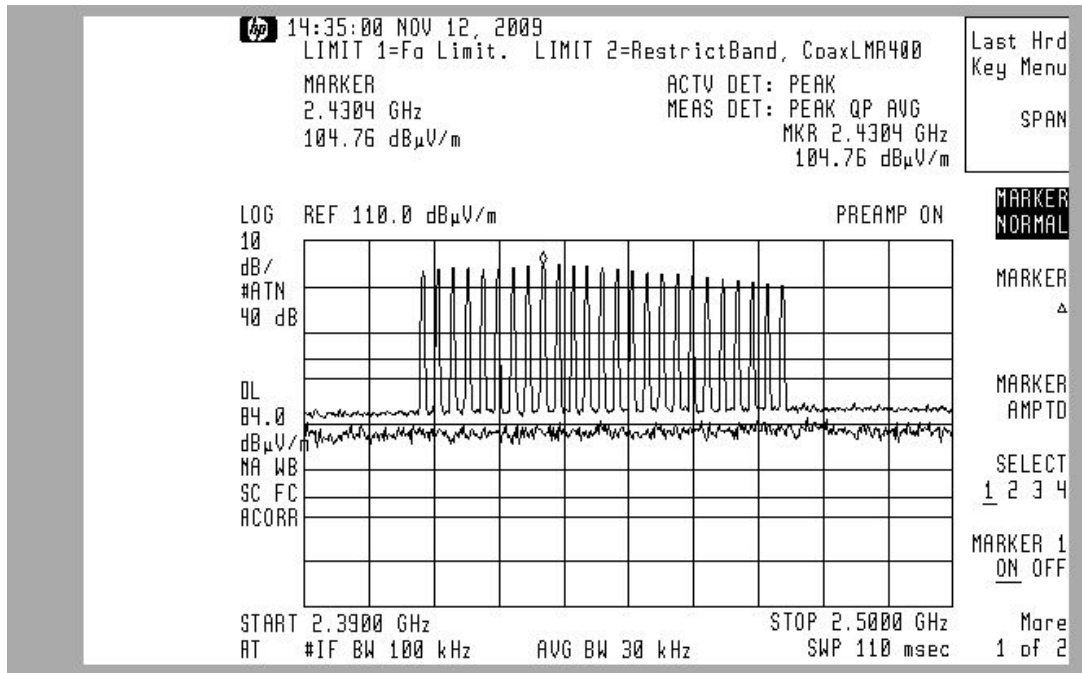

20 dB Bandwidth Plot

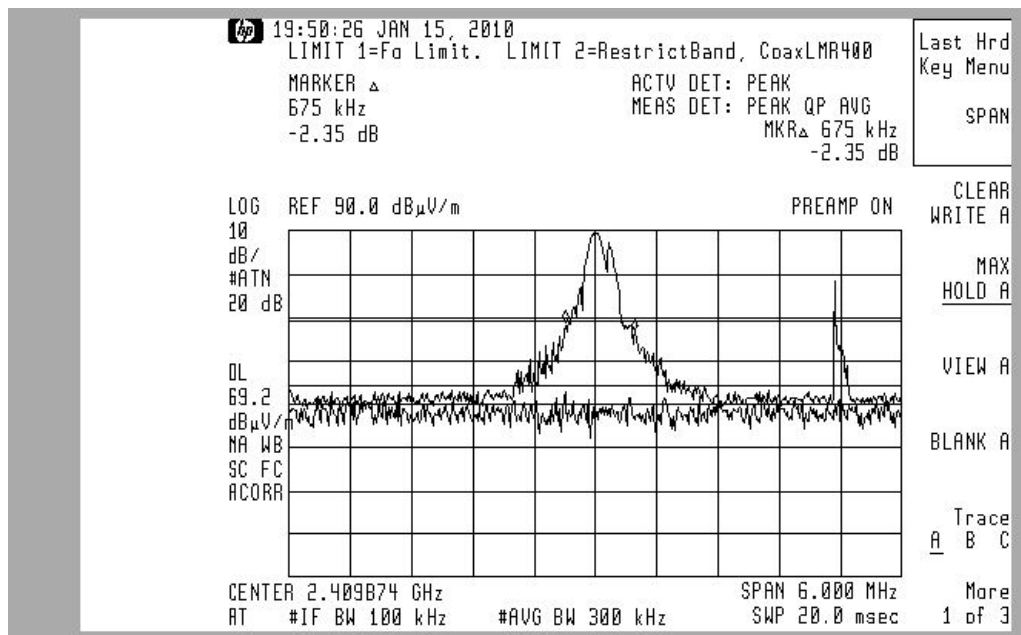

Carrier Separation

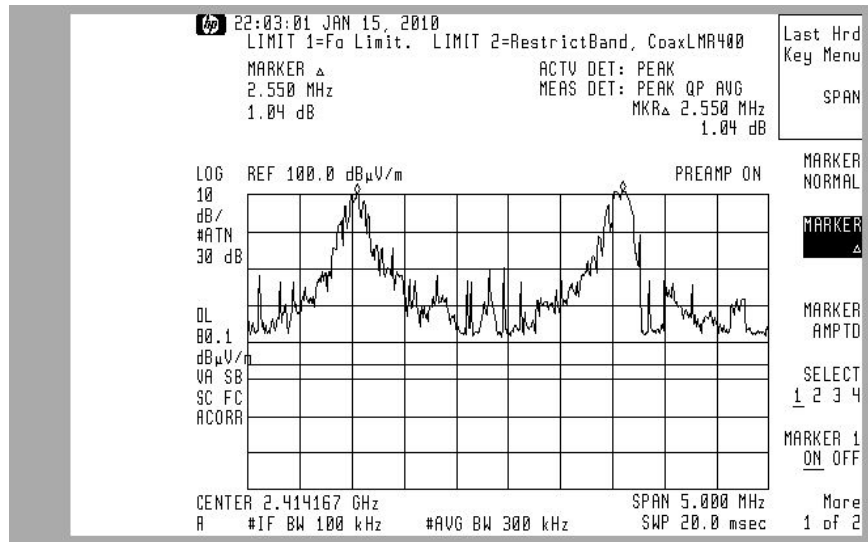

100kHz BW In Band Max Signal

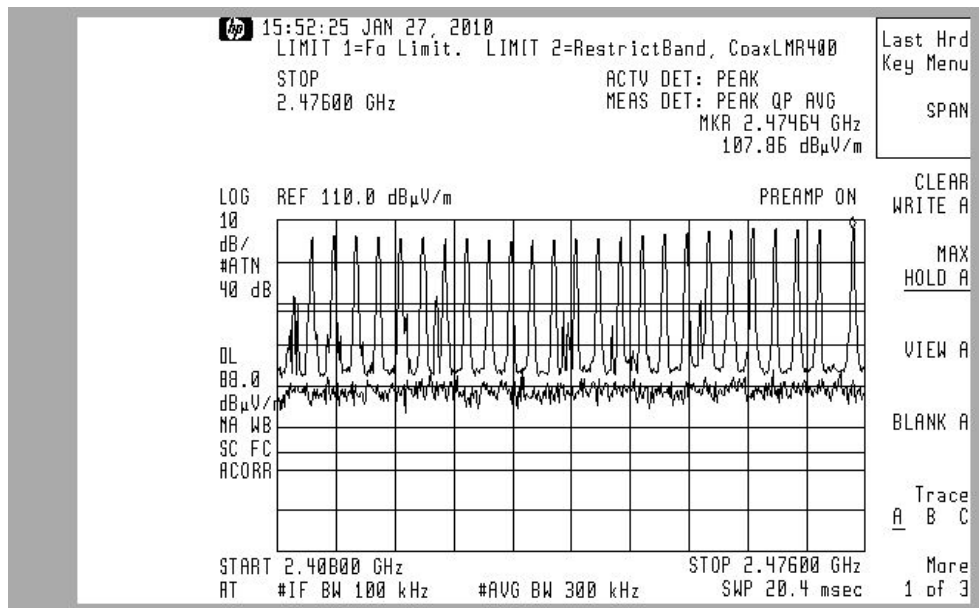

100kHz BW In Band Low End Max

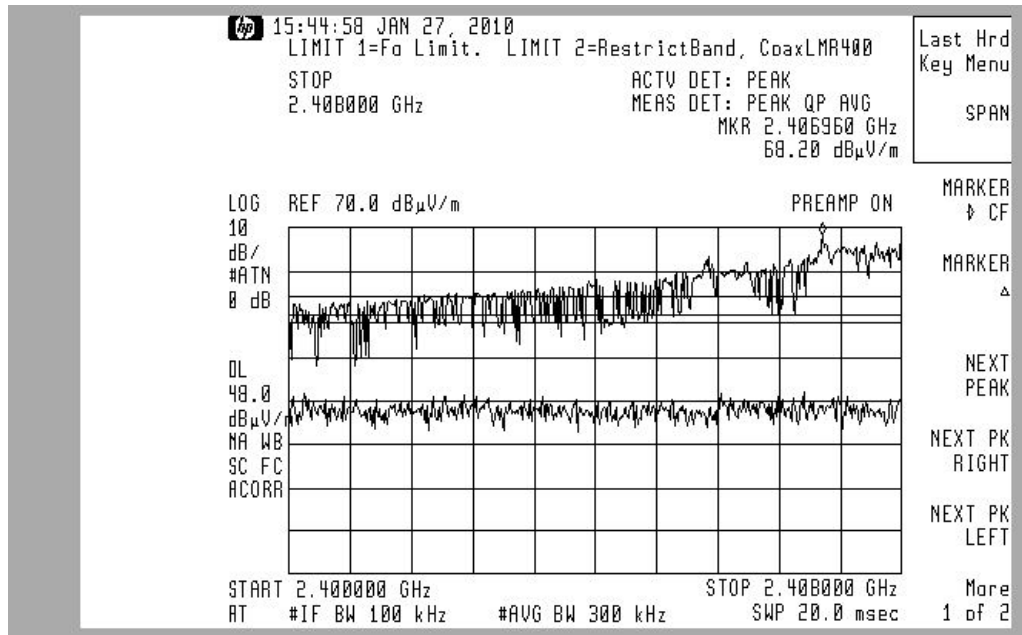

100kHz BW In Band High End Max

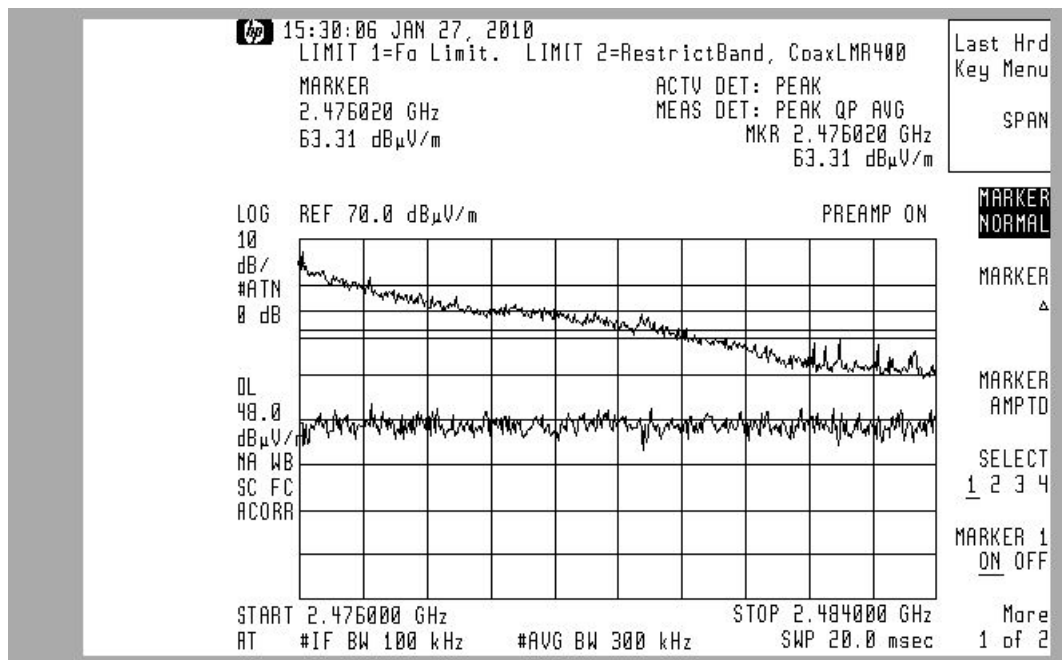

Tabulated 15.247 Frequency Hopping Data

15.247 Reference	Spec Data	Units	Spec	Data	Margin
	Operating Mode		Frequency Hopper / Digital Modulation	Frequency Hopper	NA
a.1	Min # of channels		15	26	11
a.1	Channel Carrier Frequencies		2400-2483	2410-2475	NA
a.1	channel 20 dB BW	MHz	None	0.675	NA
a.1	Min Carrier separation	MHz	0.675	2.55	1.88
a.1	hopping algorithm		Pseudo Random, equal distribution		
a.1.iii	max time occupied per channel	mSec	400	374.16	25.84
b.1	max power (eirp)	mW	125	2.25	122.75
b.4	max antenna gain		6	2.15	3.85
d	measured in band 100 KHz BW signal	dBuV	None	107.86	NA
d	measured in band "skirt" 100KHz BW signal	dBuV	87.86	68.2	19.66
d	max in band 100 KHz BW Power	dBm	None	12.63	NA
d	max in band "skirt" 100KHz BW Power	dBm	-7.37	-27.03	19.66

RF Exposure Calculation:**Tabulated RF Exposure Calculations**

FCC Spec Reference	Spec Data	Units	Spec	Data	Margin
KDB 447948 D01	min SAR Evaluation Limit = 60/2.45GHz	mW	24.490	1.140	23.350
15.203	Fixed Antenna	NA	Antenna unchangeable by end user	Integrated PCB Antenna	
1.1310	Max Occupational Exposure (assuming distance of 2.5cm) using formula $EIRP/(4*(\pi)*(d^2))$	mW/cm ²	5.000	0.015	4.985
1.1310	General Population Exposure (assuming distance of 2.5cm) using formula $EIRP/(4*(\pi)*(d^2))$	mW/cm ²	1.000	0.015	0.985

Measurement Facilities & Equipment

Test Site

The AHD test facility is centered on 9 acres of rural property near Sister Lakes, Michigan. The mailing address is 92723 Michigan Hwy152, Sister Lakes, 49047. This test facility is NVLAP accredited (LabCode 200129-0). It has been fully described in a report filed with the FCC (No.90413) and Industry Canada (file:IC3161).

Measurement Equipment Used

Equipment	Model	S/N	Last Cal Date	Calibration Interval
HP EMI Receiver system	HP 8546A			
RF Filter Section	HP-85460A	3448A00283	25 July-09	12 months
RF Receiver Section	HP-85462A	3625A00342	25 July-09	12 months
EMCO BiconiLog Antenna	3142	1069	27-July-09	12 months
Solar LISN	8012-50-R-24-BNC	962137	3-Aug-09	12 months
Solar LISN	8012-50-R-24-BNC	962138	23-July-09	12 months
(LCI) Double shielded 50ohm Coax	RG58/U	920809	11-Mar-09	12 months
(3-m) LMR-400 Ultra Flex	LMR400	C090804	4-Dec-09	6 months
(3-m) CS-3227 RG8	CS-3227	C060914	4-Dec-09	6 months
(10-m) Amelco 50ohm Coax	RG213U	9903-10ab	4-Dec-09	6 months
Double Ridged Horn	ONO91202-2	A00329	27-July-09	12 months
Keytek Surge	711B	8511854	05-Jan-09	12 months
Schaffner ESD	NSG432	01027	04-Jan-09	12 months
Schaffner EFT	NSG600/641	0113	05-Jan-09	12 months

Test Site 2

The University of Michigan test facility is located at 8501 Beck Road, Belleville, Michigan 48111. This test facility has been fully described and accepted by the FCC and Industry Canada. This facility was utilized to measure emissions occurring at frequencies greater than 6GHz.

Measurement Equipment Used

Equipment	Model	S/N	Last Cal Date	Calibration Interval
C-Band Std. Gain Horn	UM NRL design		calibration by design & physical inspection.	
XN-Band Std. Gain Horn	UM NRL design		calibration by design & physical inspection.	
X-Band Std. Gain Horn	SA 12-8.2	730	calibration by design & physical inspection.	
Avantek RF amplifier	AFT-12665		28-July-09	12 months
3ft LowLoss coax	RG142	-	with Avantek amp	
Spectrum Analyzer	HP 8593E	3412A01131	2-June-09	12 months

Environment

The test was performed with the equipment under test, and measurement equipment inside the all-weather enclosure. Ambient temperature was 67 deg F, the relative humidity 35 %.

APPENDIX A

Measurement Procedures

Line Conducted

The system was placed upon a 1 x 1.5 meter non-metallic table 80cm from the ground floor and 40cm from the vertical conducting plane in the prescribed setup per ANSI C63.4. This table is housed in a shielded enclosure to prevent the detection of unwanted ambients.

The EUT, or host unit if applicable, was connected to the LISN being monitored by the EMI Receiver. The remaining support devices requiring mains power were connected to a second LISN.

The EUT was continuously exercised by methods supplied by the manufacturer.

While monitoring the display of the EMI Receiver, via remote video monitor, the cables were manipulated to determine a position that maximized the emissions being observed. Once the highest amplitude relative to the limit was determined for the Phase current carrying line the procedure was repeated for the Neutral current carrying line.

The configuration that created an emission closest to the limit was used during the course of taking final measurements. Pictures of this final configuration are recorded in this report.

The principal settings of the EMI Receiver for line conducted testing include:

Bandwidth = 9KHz

Detector Function: scanning and signal search = Peak Detection Mode
measurements = Quasi Peak Detection and Average Detection

The cable losses of the coax used in line conducted testing are charted in this appendix.

Radiated

The system was placed upon a 1 x 1.5 meter non-metallic table 80cm from the open field site ground plane in the prescribed setup per ANSI C63.4, Figure 9(c).

The table sits upon a remote controlled turntable. The receiving antenna, located at the appropriate standards distance of 3 or 10 meters from the table center, is also remote controlled.

The EUT was continuously exercised by software supplied by the manufacturer.

Preliminary tests were done at the 3 meter open field test site. The final tests are done at the appropriate standards distance of 3 or 10 meters. The "Biconical/Log Periodic" broadband antenna connected to an EMI Receiver, meeting CISPR 16, is used throughout the testing.

During the preliminary scans and while monitoring the display of the EMI Receiver, the turntable was rotated 360 degrees and the receiving antenna height varied from 1 to 4 meters to search out the highest emissions. At the significant emissions, the cables were manipulated to determine a position that maximized the emissions being observed. Once the cable position was determined that presented the highest amplitude relative to the limit for Vertical polarized emissions the procedure was repeated for the Horizontal polarization.

The configuration that created an emission closest to the limit was used during the course of taking final measurements. Pictures of this final configuration are recorded in this report.

The principal settings of the EMI Receiver for radiated testing include:

Bandwidth: 120kHz

Detector Function: scanning and signal search = Peak Mode
measurements = Quasi Peak Mode.

Search Range: 30MHz to 1000MHz or to 2GHz as appropriate

The cable loss of the coax used in radiated scanning is charted in this appendix.

The antenna factors, for the test distance used, are charted in this appendix.

The resultant Field Strength (FS) is a summation in decibels (dB) of the Indicated Receiver Level (RF), the Antenna Correction Factor (AF), and the Cable Loss Factor (CF). If a PreAmplifier (PA) is used, its gain (dB) is subtracted from the above sum.

Formula 1: $FS(\text{dBuV/m}) = RF(\text{dBuV}) + AF(\text{dB/m}) + CF(\text{dB}) - PA(\text{dB})$

To convert the Field Strength dBuV/m term to uV/m, the dBuV/m is first divided by 20. The Base 10 AntiLog is taken of this quotient. The result is the Field Strength value in uV/m terms.

Formula 2: $FS(\text{uV/m}) = \text{AntiLog}[(FS(\text{dBuV/m}))/20]$

Cable Loss

Line Conducted 150KHz through 30MHz, Coax #920809
Last Calibration date: Mar 11, 2009

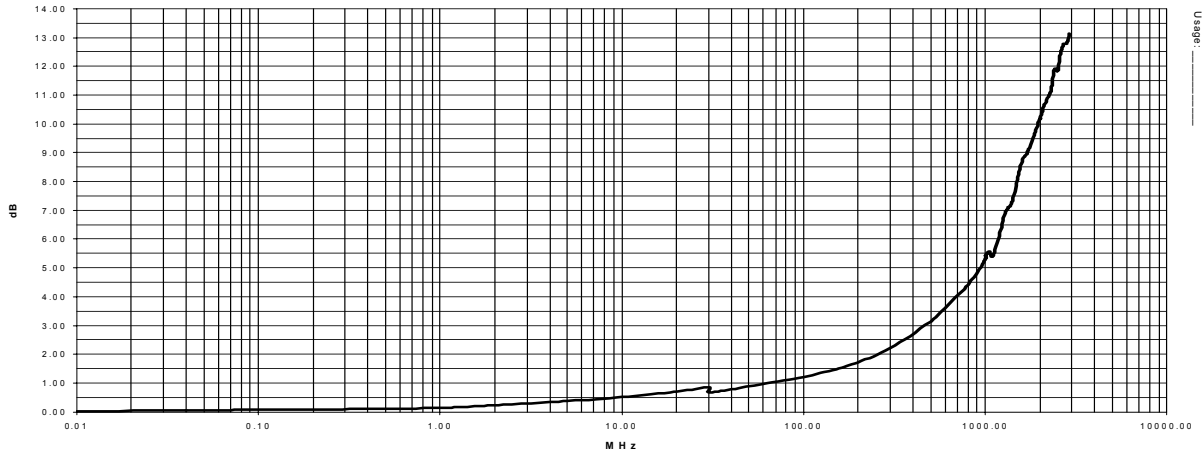

Radiated at 3 meters; 30MHz through 3000MHz, Coax #C090804

Last Calibration date: Dec 04, 2009

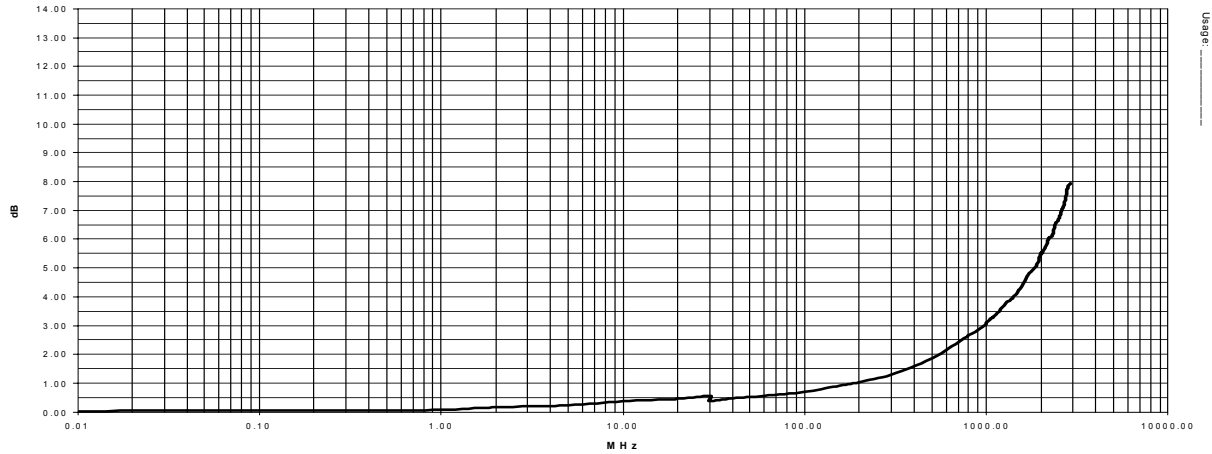

Antenna Factors

EMCO Model 3142 Antenna #1069

Last Calibration Date; 27-July-09

3 Meter Distance Factors

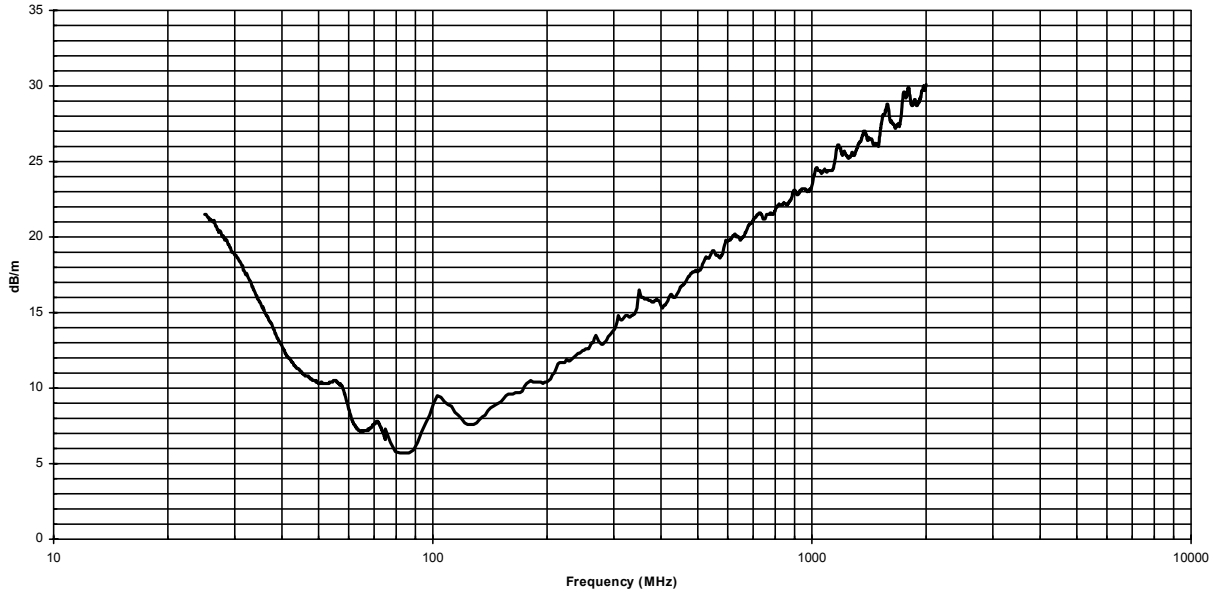

10 Meter Distance Factors

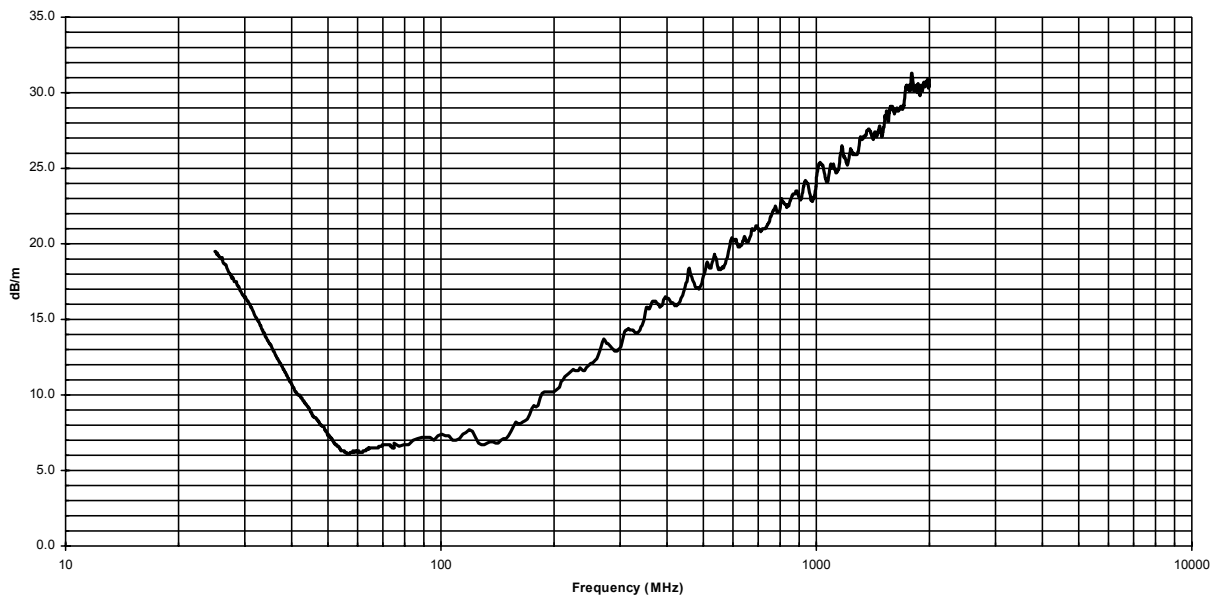

AHD Accreditation

United States Department of Commerce
National Institute of Standards and Technology

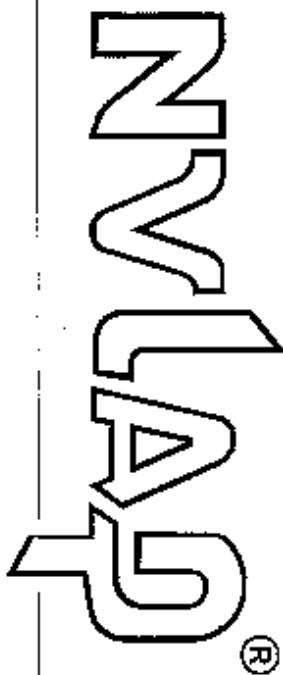

Certificate of Accreditation to ISO/IEC 17025:2005

NVLAP LAB CODE: 200129-0

AHD (Amber Helm Development, L.C.)
Dowagiac, MI

*is accredited by the National Voluntary Laboratory Accreditation Program for specific services,
listed on the Scope of Accreditation, for:*

ELECTROMAGNETIC COMPATIBILITY AND TELECOMMUNICATIONS

*This laboratory is accredited in accordance with the recognized International Standard ISO/IEC 17025:2005.
This accreditation demonstrates technical competence for a defined scope and the operation of a laboratory quality
management system (refer to joint ISO-ILAC-IAF Communiqués dated January 2009).*

2009-07-01 through 2010-06-30

Effective dates



Dolly S. Bueser
For the National Institute of Standards and Technology

NVLAP-07-C (REV. 2008-01-28)

FEDERAL COMMUNICATIONS COMMISSION

Laboratory Division
7435 Oakland Mills Road
Columbia, MD 21046

April 16, 2008

Registration Number: 90413

AHD EMC Laboratory
92723 M-152,
Dowagiac, MI 49047

Attention: Gordon Helm

Re: Measurement facility located at Sister Lakes
3 & 10 meter site
Date of Renewal: April 16, 2008

Dear Sir or Madam:

Your request for renewal of the registration of the subject measurement facility has been received. The information submitted has been placed in your file and the registration has been renewed. The name of your organization will remain on the list of facilities whose measurement data will be accepted in conjunction with applications for Certification under Parts 15 or 18 of the Commission's Rules. Please note that the file must be updated for any changes made to the facility and the registration must be renewed at least every three years.

Measurement facilities that have indicated that they are available to the public to perform measurement services on a fee basis may be found on the FCC website www.fcc.gov under E-Filing: OET Equipment Authorization Electronic Filing, Test Firms.

Sincerely,



Phyllis Parrish
Industry Analyst

NARTE Seal

