

The SPT Operator Manual

Smart Panel Technology



CONTENTS

Information & Disclaimer	5
Read this First	6
FCC compliance.....	6
Important Safety Information	7
Save these Instructions.....	7
Markings	9
Servicing.....	9
Message from Ampt	10
Why SPT – Why get Ampt?	11
Smart Panel Technology Overview	12
In simple terms, the SPT:	13
Here’s how it works:	14
Theory of Operation	16
SPT Fundamentals:	16
Introduction to Logic Matrix (summary version)	17
Value proposition list.....	18
Test results	18
Internal testing	18
Third party validation	18
Safety and convenience features	19
Full system diagram	19
Energy vs power	19
LCOE.....	20
Maximum Power Point Tracking.....	21
GUI – graphical user interface & Software User Manual.....	22
Overview.....	22
Data base and trend analysis.....	25
Complete system layout and Wiring Diagram	26
Communication system layout	26
Designing your SPT system solution	27
Ordering information – Sample Sales Order.....	28

Quick Install Guide.....	30
SPT Installation	34
Mechanical mounting SPT to the PV module	34
Wiring SPT to the PV module.....	34
Completing the string wiring	34
HRD Installation	35
Mechanical mounting the HRD.....	35
Wiring the HRD	35
Completing the home run wiring.....	35
Gateway and Field Computer	35
Location determination	35
System requirements.....	35
AC power	35
Internet Access	35
Mechanical mounting	35
Electrical wiring.....	35
SPT System Commissioning	36
Mapping your system	36
Using the Hand Held FC	36
Power up the FC	36
Verify gateway operation	36
Testing the signal strength to the Gateway.....	36
Accessing the FC through the internet	36
Setting up the GUI	36
Defining users and administrative functions	36
Choosing the user defined parameters	36
Alert Thresholds.....	36
Script choices.....	36
Summary page	36
Setting up the data base.....	37
Operating Instructions.....	37
Reading the GUI.....	37
Control features.....	38
Normal operation	38

What you see	38
How to interpret	38
How to modify	38
Accessing the data base.....	38
Sorting the data	38
Defining user templates.....	38
Interpreting alert messages.....	38
Troubleshooting	39
SPT operational issues	39
GUI operational issues	39
Technical Data	40
SPT specifications sheet.....	40
SPT Photo & Mechanical Drawing	40
HRD specifications sheet	42
HRD Illustration.....	42
HRD Mechanical Drawing	42
FC specifications sheet	43
Hand Held FC specifications sheet.....	44
GUI parameters and system requirements	45
Technical Support	46
Information Regarding the SPT:.....	46
Information Regarding the PV modules:	46
Limited Warranty.....	47
Warranty Conditions.....	47
Exclusion of Liability.....	47
for Warranty Returns & Installer Replacement:.....	47
Appendix:.....	49
FAQ	49
Installation Mapping.....	49
Wiring Diagrams	49
Ordering spare or replacement parts	49
Return procedures.....	49
White Papers	49
Presentations.....	49

INFORMATION & DISCLAIMER

Copyright © 2009 Ampt LLC. All rights reserved.

No part of this document may be reproduced, retransmitted, or copied in any form without the expressed and written permission of Ampt.

Ampt makes no representations, expressed or implied, that with respect to this documentation or any of the equipment and/or software it may describe, including (with no limitation) any implied warranties of utility, merchantability, or fitness for any particular purpose. All such warranties are expressly disclaimed. Ampt shall not be liable for any indirect, incidental, or consequential damages under any circumstances. (The exclusion of implied warranties may not apply in all cases under some statutes, and thus the above exclusion may not apply.)

The following specifications are subject to change without notice, even though every attempt has been made to make this document complete, accurate and up-to-date. Readers are cautioned, however, that Ampt reserves the right to make changes without notice and shall not be responsible for any damages, including indirect, incidental or consequential damages, caused by reliance on the material presented, including, but not limited to, omissions, typographical errors, arithmetical errors or listing errors in the content material.

Ampt LLC
4850 Innovation Drive
Fort Collins, Colorado 80525
Tel 970-372-6950
www.ampt.com

READ THIS FIRST

This operator manual contains all of the information needed to install, commission, and operate an Ampt SPT distributed power conversion device within a grid-tied photovoltaic (PV) installation.

To help avoid problems during the system installation, familiarize yourself in advance, with the installation process by reading the entire Installation Guide before starting the installation.



Be alert! There are extremely dangerous and lethal voltages present at various points in a PV system. For safety reasons, it is recommended that only qualified personnel install and operate this equipment.

FCC COMPLIANCE

Ampt SPT - This equipment has been certified as compliant with the limits for a Class B digital device, pursuant to Part 15 of the FCC Rules. These limits are designed to provide reasonable protection against harmful interference in a residential installation. This equipment generates, uses, and can radiate radio frequency energy and if not installed and used in accordance with the instructions, may cause harmful interference to radio communications. However, there is no guarantee that interference will not occur in a particular installation.

The user is cautioned that changes or modifications not expressly approved by Ampt LLC. could void the user's authority to operate this equipment.

Ampt SPT FCC ID # XLQ31570001
SPT Model Number: 31570001

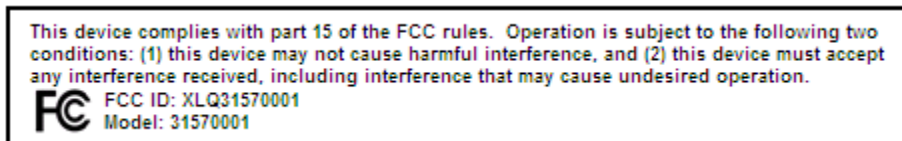

This label is found on each Ampt SPT enclosure.
The box is two pieces and is not meant to be user serviced or opened in any way.

Ampt Gateway FCC ID #
Gateway Model Number: 31570002

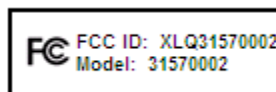

This label is found on each Ampt Gateway enclosure.
The box is smaller than palm size, thus the following text is only printed here:

This device complies with part 15 of the FCC rules. Operation is subject to the following two conditions: (1) this device may not cause harmful interference, and (2) this device must accept any interference received, including interference that may cause undesired operation.

The box is two pieces and is not meant to be user serviced or opened in any way.

IMPORTANT SAFETY INFORMATION

SAVE THESE INSTRUCTIONS

This manual contains important instructions for the Ampt SPT distributed power conversion device that shall be followed during installation and maintenance of the module and affiliated hardware and software. The SPT has been designed and tested according to international safety requirements, but requires certain precautions are observed when installing and/or operating the Ampt SPT product. To reduce the risk of personal injury and to ensure the safe installation and operation of the SPT, please be sure you carefully read and follow all instructions, cautions and warnings in this operator manual.

Warnings

A Warning identifies a hazard to equipment or personnel. It calls attention to a procedure or practice, which, if not correctly performed, could result in damage to or destruction of part or all of the Ampt equipment and/or other equipment connected to the Ampt equipment or personal injury.



DANGER indicates a hazardous situation which, if not avoided, will result in death or serious injury.

WARNING indicates a hazardous situation which, if not avoided, could result in death or serious injury.

CAUTION indicates a hazardous situation which, if not avoided, could result in minor or moderate injury.

NOTICE indicates a situation that can result in property damage if not avoided.

In addition to the safety and hazard symbols the following is also used in this Operator Manual:



Information - This symbol accompanies notes that call attention to supplementary information that you should know and use to ensure optimal operation of the Ampt system.

General Warnings:



All electrical installations must be done in accordance with the local and National Electrical Code ANSI/NFPA 70.



The Ampt product contains no user-serviceable parts. For all repair and maintenance always return the unit to an authorized Ampt Service Center. Before installing or using the Ampt SPT, read all of the instructions, cautions, and warnings on the SPT, the PV array, in this Installation

Guide. Before connecting the SPT to the electrical utility grid, contact the local utility company. This connection must be made only by qualified personnel. PV arrays produce electrical energy when exposed to light and thus can create an electrical shock hazard. Wiring of the PV-arrays should only be performed by qualified personnel.

MARKINGS

	CAUTION	UL 1741  244284
	Risk of Electric Shock, Do Not Remove Cover. No User Serviceable Parts Inside. Refer Servicing To Qualified Service Personnel. When the photovoltaic array is exposed to light, it supplies a dc voltage to this equipment	
AMPT Model Number		31570001-00
Range of Operating DC Voltage (MPP Tracking)		20.6 - 51.0 V dc
Maximum Operating Current (DC Input)		7.5 A
Operating Input Voltage Range (DC)		20.6 - 56.0 V dc
Operating Output Voltage Range (DC)		0 - 55 V dc
Maximum Continuous Output Current (DC)		7.5 A
Maximum Continuous Output Power (DC)		240 W
Enclosure Type		3R

SERVICING



Warnings:

1. When the photovoltaic (PV) array is exposed to light, it produces a DC voltage, and the Ampt equipment is energized.
2. Servicing instructions are for use by qualified personnel only. To reduce the risk of electric shock, do not perform any servicing other than that specified in these Operating Instructions.
3. The installation of Ampt equipment requires following the National Electrical Code (ANSI/NFPA 70) wiring methods.
4. CAUTION: To reduce the risk of fire, connect the outputs of the Ampt Equipment only to conductors with a minimum ampacity of 9.4 amperes when de-rated for temperature and conduit fill. Over-current protection devices and conductors shall be sized in accordance with the National Electrical Code (ANSI/NFPA 70).
5. Ampt requires over current protection for the DC output circuit in the installation.
6. Ampt recommends that a disconnect switch be included in the installation for the DC input and DC output circuit as required by the local authorities.

7.

MESSAGE FROM AMPT

The first products that Ampt is introducing are a result of looking at requirements to realize maximum energy at the lowest cost – from a system level perspective.

This initial premise is that the maximum energy cannot be harvested fully without the right granularity. We believe that this requires power conversion to be done at the module level. Our customers require minimal lost harvest from local soiling, shading, or panel imbalance– so with regards to local power conversion, there is no more suitable economic alternative.

We believe that the power conversion has to be extremely efficient over a very wide range – so our products are over 99% efficient over greater than 3:1 input range. To put that into context, the Ampt SPT consumes only, up to 2W of the energy generated by a 200W module – relatively speaking that is the same loss as expected from energy traveling through 3 feet of conventional wire cabling.

We believe that high speed MPP is very critical to maximize harvest – we have over 99.9% accurate MPP in 100 milliseconds. Therefore, we can capture the power gain from the edge of a cloud and the refracted irradiation on a module.

We believe that maximizing the number of modules per string is important. The Ampt product is dynamically controlled, and we can communicate wirelessly to our field adaptable firmware.

We believe that reliability is a huge drive of economics – so we have an environmentally validated (not superficially modeled) 1000 year MTBF.

We believe that high accuracy and stable instrumentation combined with robust communication is crucial for large-scale arrays and beneficial for all smaller arrays. It lowers installation costs, and radically reduces O&M while maximizing the economics of harvesting. We have a better than 1% field calibrate-able measurement system that includes multiple channels of critical electrical and temperature parameters, as well as identity information – per module.

We believe that communication alone isn't sufficient. These applications need scalability and robustness that does not depend on problematic connections. We designed a highly robust wireless system.

We believe that if the system is designed with the right granularity, with the right components, with the right interfaces and the right architecture that it becomes unlimited in its ability to operate at any scale. We have designed this system to allow scaling from one module to above a million modules.

Thank you for Continued Support – we look forward to working with you!

We are Ampt.

WHY SPT – WHY GET AMPT?

What is maximum power?

Is it defined by the energy output of the weakest module in a string,

or the combined output of every single module on every string?

Is it defined by analyzing energy harvest each day at one site,

or every second on every panel at one million sites?

Is it defined by the monitoring of information within an array,

or the communication of knowledge that leads to improved performance within every module?

By answering what no one else has even yet asked, Ampt is not just increasing energy,

but helping you to realize energy you never knew possible.

Congratulations on putting the absolute best communications and power conversion equipment available on your PV system!



SMART PANEL TECHNOLOGY OVERVIEW

Ampt has developed Smart Panel Technology™ - **SPT** - as the optimal solution for energy harvesting from any PV system.

The first implementation of Ampt SPT is in a standalone device that is placed in direct connection with the PV module to deliver MPPT (Maximum Power Point Tracking) which is the harvested energy. Conventional PV systems have solar modules series connected, and are thereby limited by the weakest module in the string. These strings are wired to a bulk DC-AC inverter which uses algorithms to attempt a maximum harvest given the potential from each string.

The Ampt solution: Distributed MPPT for large scale deployments

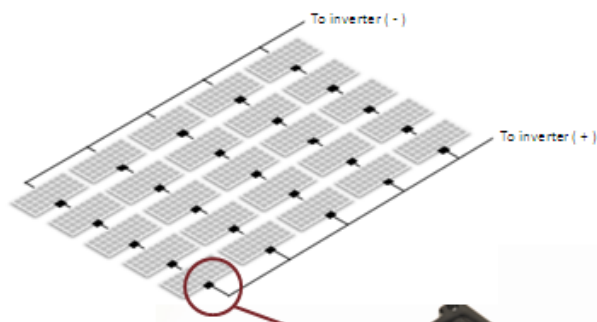

Ampt converter

DC-DC power converter with MPPT on each PV module provides instrument-grade measurement and wireless communication capabilities.

External – Ampt converter externally connected with each PV module.

Integrated – Ampt converter integrated on PV modules during manufacture.

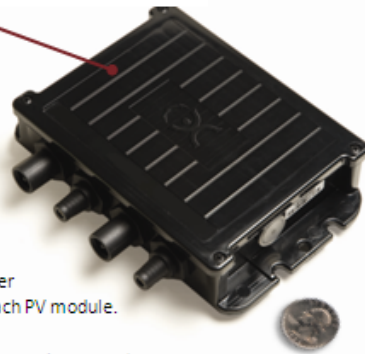

Ampt software

Comprehensive web-based application for remote management and analysis of a single or multiple PV systems at the module, string, and array levels.



Communication gateway

Wireless communication with every Ampt module, that links to the web and other external devices.

The Ampt SPT puts the MPPT logic where it belongs, on each solar module, and allows each module to produce its maximum power. Then each SPT device combines to provide the bulk inverter with its highest efficiency input power. The result: the highest energy from each module, operating with the highest efficiency of the bulk inverter.

MPPT - where it belongs

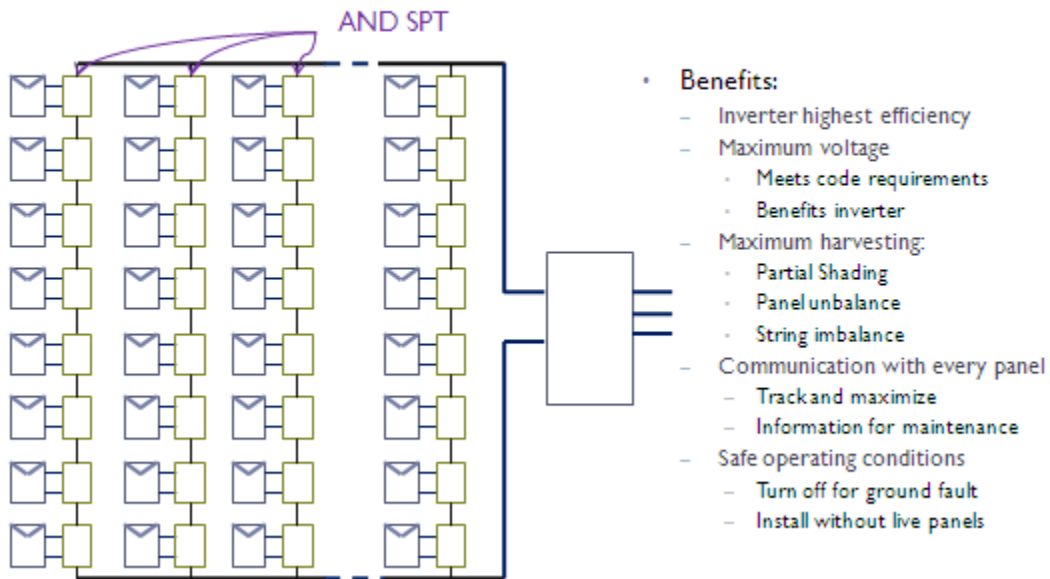

IN SIMPLE TERMS, THE SPT:

- Receives the power from the module at its Maximum Power Point Tracking (MPPT) regardless of normal or problematic operating conditions
- Delivers module MPPT power into any impedance determined by the remainder of the string and the inverter
- Solves the problem of having panels (current sources) in series being limited by the weakest panel in the string- improves string sighting options
- Ensures every panel produces whatever it can regardless of the remainder of the system
- Allows the inverter to operate at its highest efficiency point
- Provides wireless communication on each module, reporting more than just panel voltage, current and temperature. Additional information is resident such as module serial number and manufacturing information
- Wireless communication also provides diagnostic information for maintenance, and through radio commands the output can be turned on/off

HERE'S HOW IT WORKS:

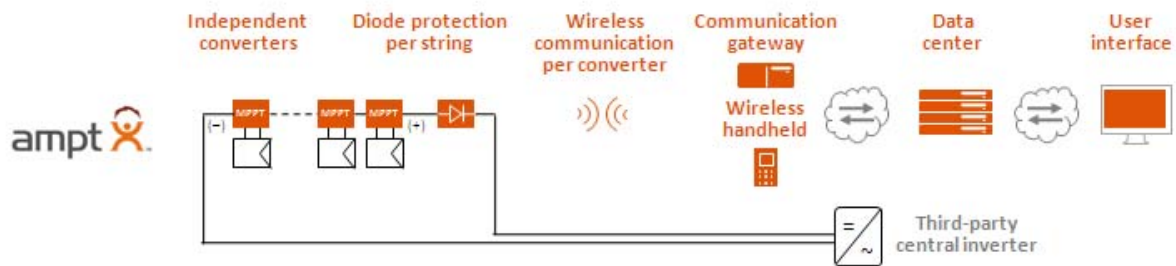

Each solar module will have a dedicated Ampt SPT device connected to the module outputs. The Ampt SPT devices then are connected in series to each other and will make up a “string” of modules. Each string is then combined in parallel to connect with the bulk inverter (in today’s conventional array).

When solar rays are absorbed by the PV module, energy is produced. The SPT maximizes the harvestable energy from each PV module, and converts it to a useful output that is then delivered to the string (regardless of the environmental or operational conditions affecting that particular panel). The strings are then combined as an array and delivered to the bulk inverter at its pre-determined impedance requirement. It is important to note that the conventional bulk inverter dynamically is searching for MPPT (maximum power point tracking), and may change its impedance requirements every 4+ seconds. The Ampt SPT however is adjusting its MPPT 8 times per second to again maximize the harvestable energy produced on each PV module.

In conventional PV installations (without the Ampt SPT), with series connected modules, one weak link in a string causes significant energy harvest degradation, and will lower the produced power produced. If there is sufficient obstruction to the amount of solar insolation absorbed by a single module (or over several modules), it is possible that the entire string collapses (electrically), and nets zero power output.

The Ampt SPT solves this problem by maximizing the power harvest at each module regardless of the conditions, and converts that to a viable output thereby eliminating the weakest link phenomenon. With Ampt SPT, even a low power producing module is valuable, and contributes to the net power generated.

Of course, if the module is damaged or obstructed to the point where its internal circuit cannot produce power, Ampt SPT cannot correct this condition. With the wireless communication link though, the owner operator can identify this condition, and make the necessary corrections. In the meantime though, the balance of the string is still operational and generating as much power as required by the bulk inverter.

Each SPT is accessible by a host computer through a wireless AND “gateway” interface. This gateway allows the owner/operator to speak specifically to each SPT, and provides a bi-directional wireless communication link which is the vehicle for command / control and data acquisition.

The AND GUI (graphical user interface) is then utilized to observe the performance and control the SPT operations. Examples of this GUI are shown below:

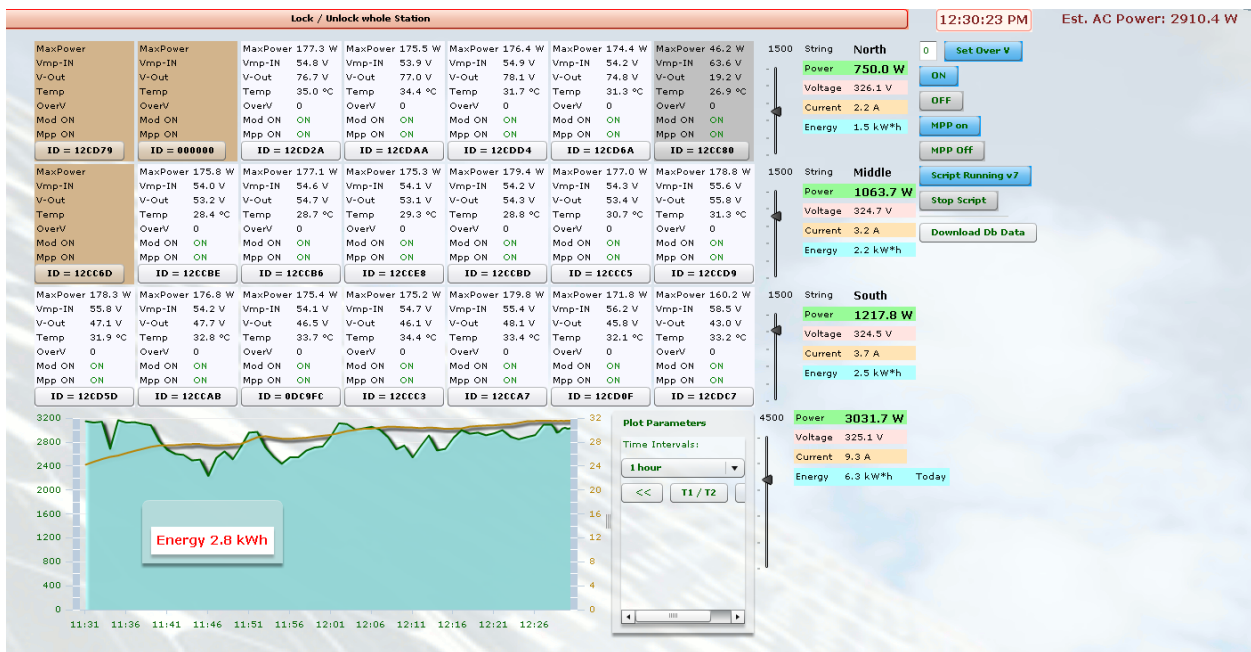
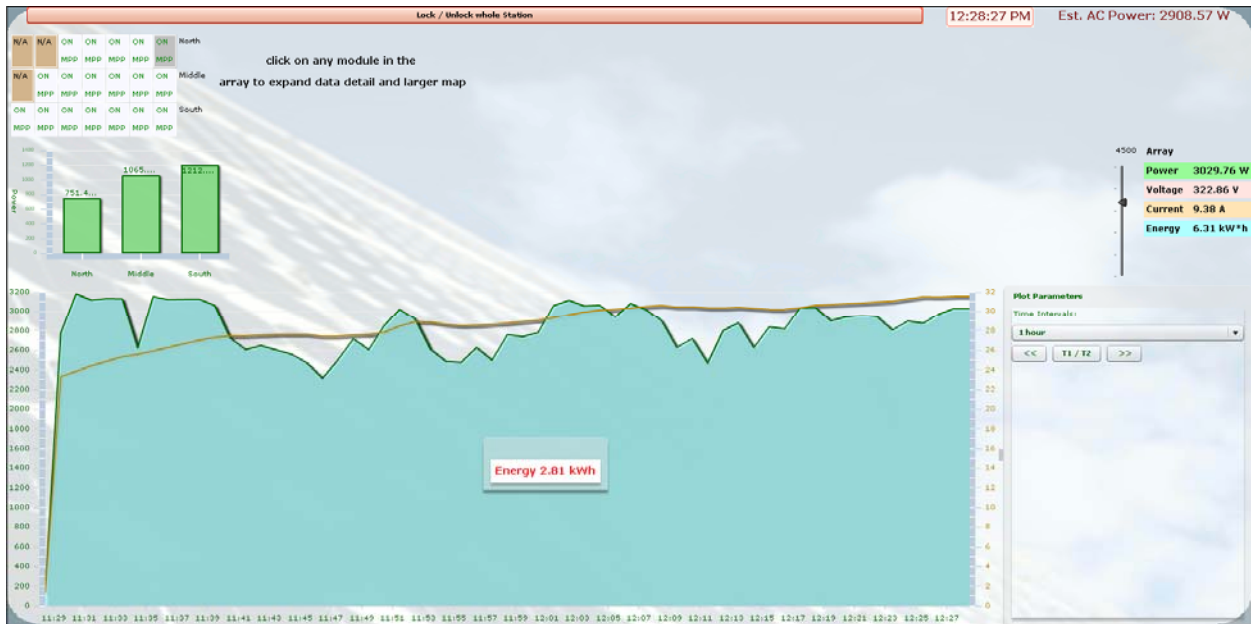

The GUI has a lot of data presented and will likely change for increased usability, but at present demonstrates the kind of interaction and reporting available.

As you can see, each module (and corresponding SPT) is mapped out per their installed location. Note: each SPT is bar coded, and during the field commissioning process, a bar code scanner can be utilized to logically map out the organization of modules. It is also possible that the bar code reader can interface to the SPT through a separate gateway, and thereby control its on/off state for field personnel safety.

That's it. With a simple installation, the Ampt SPT products operate immediately and automatically enhance the power generated by the PV installation. Ongoing monitoring and command control features are available to the owner operation, but regular interaction is not required to get maximum power.

THEORY OF OPERATION

AMPT Lossless Power Conversion Inverter Sweet Spot

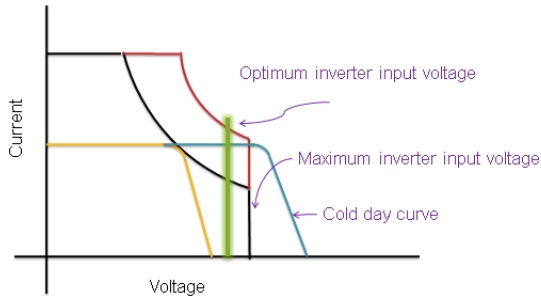

The Ampt SPT is designed to mitigate irregularities between the modules in an array and the bulk inverter. Specifically, the SPT can fix its output to match the optimal inverter input voltage and broaden the performance range of conventional PV modules & inverter combinations. By providing localized DC-DC conversion along with wireless communication, the SPT enables instantaneous control and feedback to the system and thereby maximizes energy harvesting.

SPT FUNDAMENTALS:

- The SPT module **puts MPP where it belongs**, on every panel, and produces the maximum power that is available regardless of panel condition, and regardless of the remainder of the system. If there is partial shade, dirt or panel imbalance, every panel still puts out its maximum power.
- The SPT module receives the power from the panel at MPP. It delivers the power to any impedance determined by the remainder of the string and the inverter. This solves the problem of having panels (current sources) in series being limited by the weakest panel in the string.
- The conventional bulk power inverter may impress any voltage it wants and because the SPT is deployed as a localized DC-DC converter, the panel field will simply output MPP from every panel. This allows the inverter to operate at its highest efficiency point.
- Going forward, SPT based installations can enable better bulk inverter designs that deliver higher efficiency, greater reliability, smaller and lighter as they would no longer be required to include an MPP stage.
- One of the most significant elements of the SPT is the inherent wireless communications capabilities, which enables instantaneous communication and control. The radio and ubiquitous wireless mesh network formed by SPT modules will not only report panel voltage, current and temperature, but also provide operational benefits by toggling the panel outputs on and off.
- Other information could also reside there such as serial number and manufacturing information.
- The wireless radio will also provide diagnostic information for maintenance and trend analysis thus allowing intelligent decisions on what requires service and when.

INTRODUCTION TO LOGIC MATRIX (SUMMARY VERSION)

AND Solar - Logic Matrix

Goals:

The objective of this logic matrix is to define inherent operations control, and construct a clearly structured visual GUI which displays performance characteristics of individual modules, strings and whole arrays, and a comprehensive report on DC and AC power generation, which results in yield assurance and customer knowledge, appreciation and value.

The SPT architecture has 4 basic modes of operation that require specific default conditions:

1	Radio On	There is no configurable provision for Radio Off
2	MPP On	Default condition for all SPT modes - unless instructed otherwise
3	MPP Off - Bypass ¹	Enabled via command only (and is a restricted use option) Bypass is the default if an SPT HiV (analog) failure occurs
4	Module Output Off	The SPT output is "open", and no power is delivered from this module. However, VOC on the module is not prevented

Logic Matrix Service Modes - SPT

Condition	Install ¹	Manufacturing ²	Maintenance ³	Residential	Commercial	Utility	Theft	Comments	LED Instructions
Dark default (no light)	1,2,4	1,2,4	1,2,4	1,2	1,2	1,2	1,4	Default Mode	No LED
1st Light	1,2,4	1,2,4	1,2,4	1,2	1,2	1,2	1,4	Default Mode	LED Normal Operation
Full Sun (Insolation)	1,2,4	1,2,4	1,2,4	1,2	1,2	1,2	1,4	Default Mode	LED Normal Operation
Upon Radio failure (no Xmit)	2	2,4 - Reject	2,4	1,2	1,2	1,2	4	Last known Operating Voltage & Operating Current	Indication that the Radio cannot Xmit
Upon Radio failure (no Recv)	2	2,4 - Reject	2,4	1,2	1,2	1,2	4	Last known Operating Voltage & Operating Current	Indication that the Radio cannot Recv
No Radio (Xmit or Recv)	2	2,4 - Reject	2	1,2	1,2	1,2	4	Warning required	LED indicator that the module is ON
MPP (analog) failure Bypass Mode	1,3,4	1,3	1,3,4	1,3	1,3	1,3	1,4	Except for Install, Manufacturing and Maintenance modes: "Bypass" occurs only if the MPP HiV fails	LED indicator that the module is ON
Module Removed From Circuit	1,4	1,2	1,4	1,4	1,4	1,4	1,4	Radio set to "Listen" (Recv only) Join command from P-Server only Xmit mode and disconnected from a Manufacturing Mode	Indication that the Radio is not in Xmit mode and disconnected from a network
VOC	1,2	1,2,4	1,2,4	1,2	1,2	1,2	1,4	Warning required	LED indicator that the module is ON
High Temperature	1,2	1,2,4	1,2,4	1,2	1,2	1,2	1,4	PIV & PVI Programmable System Design dependent	Indicates limit mode envoked
Low Temperature	1,2	1,2,4	1,2,4	1,2	1,2	1,2	1,4	PIV & PVI Programmable System Design dependent	Indicates limit mode envoked
Full Sun (Obstructed)	1,2	1,2,4	1,2,4	1,2	1,2	1,2	1,4	Default Mode	LED Normal Operation
Reflective Light	1,2	1,2	1,2,4	1,2	1,2	1,2	1,4	PIV & PVI Programmable System Design dependent	Indicates limit mode envoked
Wire Drop	1,2	1,2	1,2,4	1,2	1,2	1,2	1,4	Default Mode	LED Normal Operation

¹ The output should be off until the installation is complete and the module, string, and/or array are activated by the installer.

² The output should be off until the Mfg test commands the output "on" and then back to "off".

³ The output should be off until the Maintenance Personnel commands the output "on".

VALUE PROPOSITION LIST

- ✓ Temperature coefficient power losses - Temperature Effect / Fill Factor Management
- ✓ Panel obstruction/ shading (leaf/snow/haze/bird gifts) - Dynamic string adjustment to capitalize on unbalanced panel production
- ✓ Panel power variation (mismatch/aging/broken/defect) - diverse utilization and imbalance correction
- ✓ Installed efficiency (placement/wiring/opens) - More KWhr/KW production (12-15% more harvesting)
- ✓ Bi-polar balancing - +/- operations for Advanced Energy Inverter applications
- ✓ Variable Inverter operating algorithms and efficiency – delivers MPPT to inverter highest point of efficiency
- ✓ Improves string sighting options (not so POA limited)
- ✓ Conventional inverter limitations - Greater compatibility between conventional inverters and all module types (from C-SI, through a-SI, CDTe, CIGS and future designs)
- ✓ Real time command and control - Wireless Communications System & Diagnostics – no longer reliant on dispatched analysis and error correction
- ✓ Improves Safety - enabling instantaneous on/off cycling for the entire System / a targeted String / or individual Panel Module
- ✓ Enables Soft start for some inverter types

TEST RESULTS

INTERNAL TESTING

1. 90M hours Demonstrated MTBF @ 40°C continuous

Note: Initially Ampt calculated MTBF, however, the demonstrated performance is a better indicator of architectural performance.

(MTBF of 90M hrs means a failure rate of 0.01% PER 25 YEARS (warranty period) assuming 10 hours of operation per day at 40C ambient).

THIRD PARTY VALIDATION

1. Sandia
2. SWTDI (NMSU) ???
3. BEW ???

Test reports will be made available upon request

SAFETY AND CONVENIENCE FEATURES

Currently, one problem facing installers and maintenance providers of PV Systems is safety. Since conventionally, all panels are connected in series and installation and maintenance work is done during periods of irradiance, the voltage across the panels might reach dangerous levels exposing field personnel to a real danger of electrocution.

Ampt provides a “convenience” mode which supports an “on / off” mode of operation. This mode of operation essentially enables or disables the SPT output and can facilitate system installer/operators during installation, diagnostics, and maintenance tasks. It is important to recognize that this is an electrical circuit logic change and is not to be confused with a hard switch. This convenience feature is designed to enhance the protection of module handlers, including the installer, maintenance provider and potentially emergency personnel (ie. Fire Department)."

FULL SYSTEM DIAGRAM

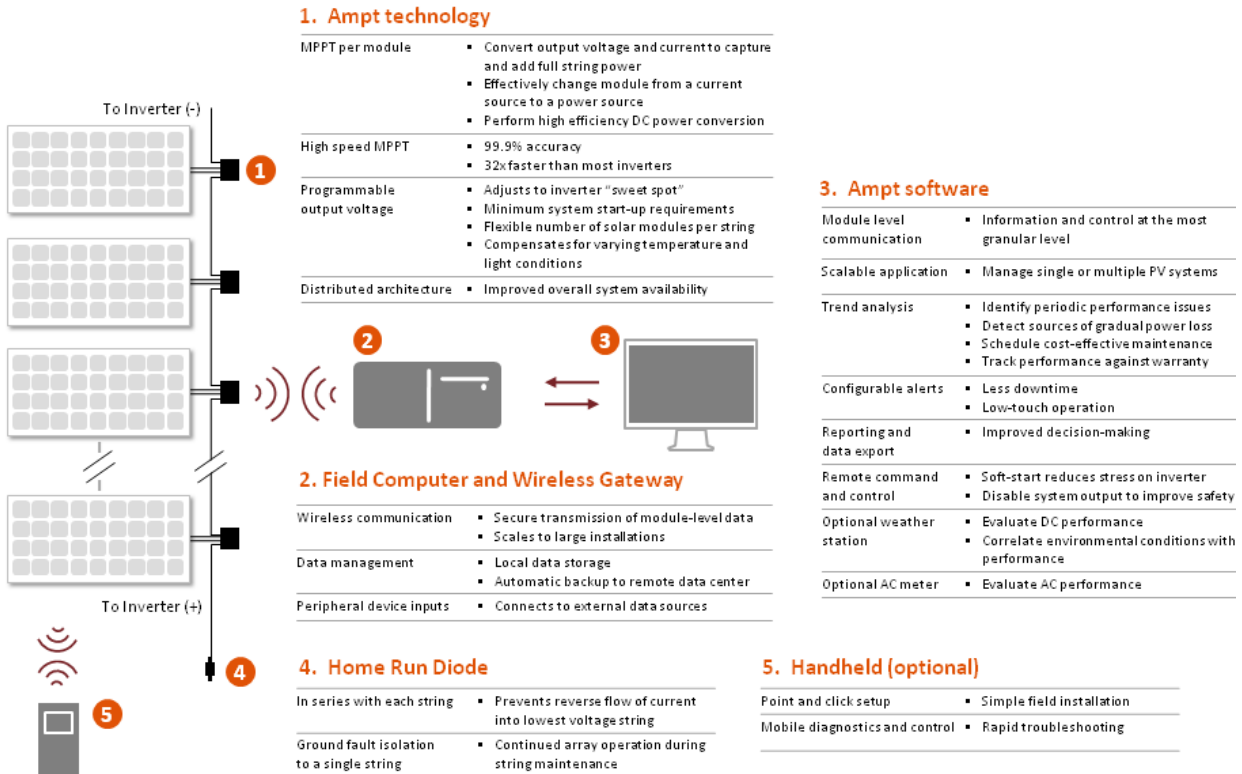

ENERGY VS POWER

Energy is the capacity of a system to do work.

Power is the rate of doing work.

Ampt lowers LCOE even on large systems

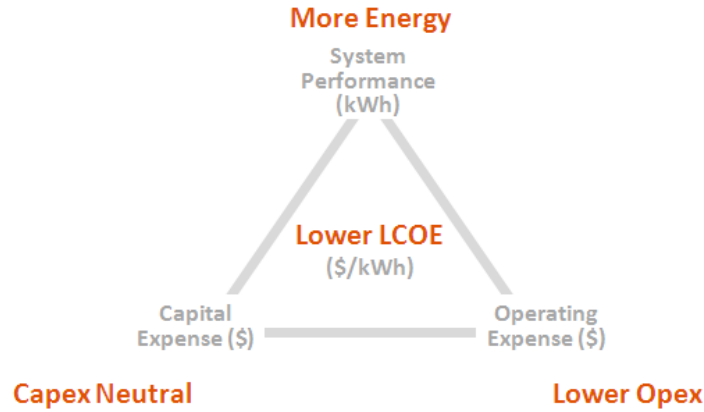

Ampt technology enables a path towards capital neutral solution that generates more energy and lowers operating costs. The result – a lower cost of energy.

Higher System Performance Ratio (PR)

Conventional vs. Ampt

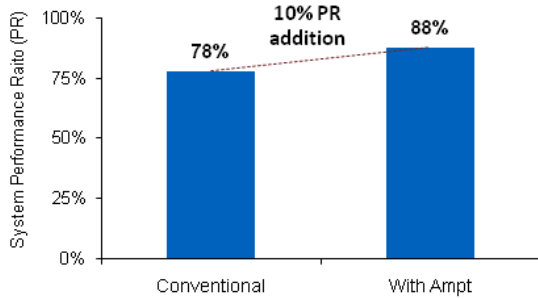

Over 10% addition to system PR achievable depending on site factors.

Lower Cost of Energy (LCOE)

Ampt Sources of Energy Cost Reduction

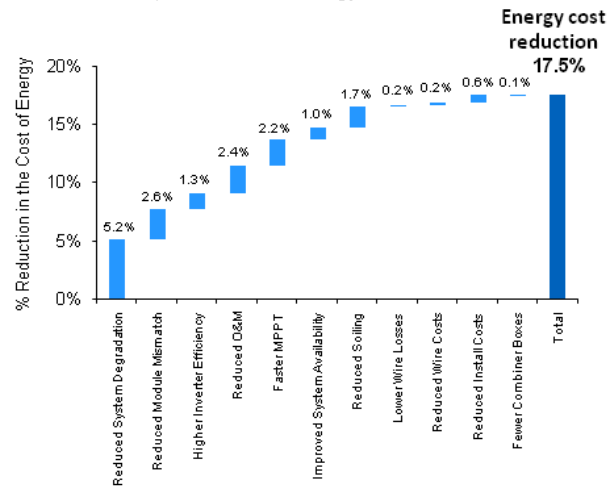

More than 17% reduction in the cost of energy achievable.

MAXIMUM POWER POINT TRACKING

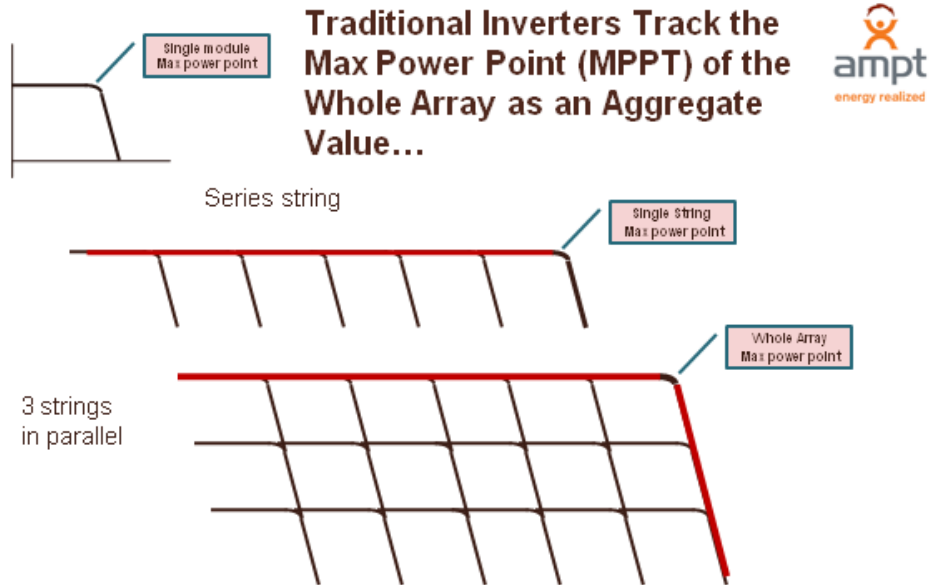

Regardless of the operating condition of each module

Distributed MPPT Provides More Energy Capture by Harvesting the Total Power Available Regardless of the Operating Conditions of Any Module or String

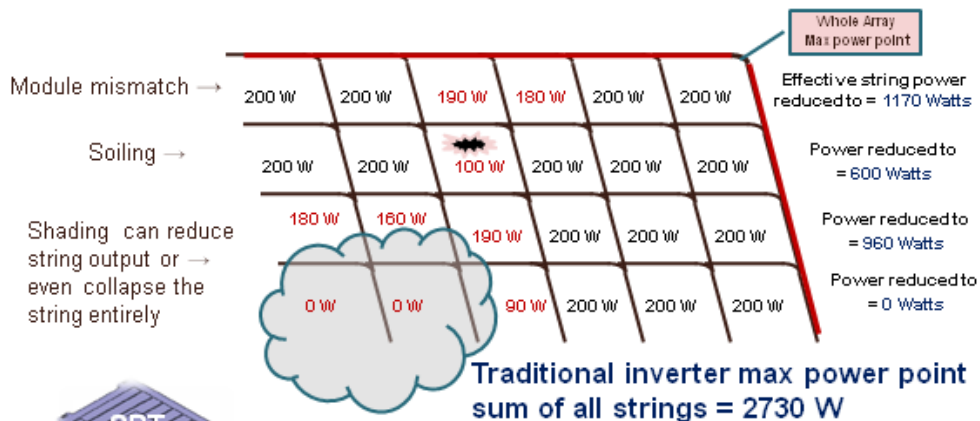

With SPT – add full max power available from all modules = 4090 W

GUI – GRAPHICAL USER INTERFACE & SOFTWARE USER MANUAL

OVERVIEW

The Ampt software is a web based management application for viewing the real-time performance and management of your solar installation at the array, string, and module level.

INTRODUCTION:

There are two views available for managing your Solar Array; summary and string view. The Summary view provides an overview of the state of the solar array. It includes current DC energy output in Watts, Volts, and Amps, power by string, SPT status, and estimated AC Power.

The String view provides detailed information on the performance of each SPT. It provides performance information at the string level; DC energy output in Watts, Volts, and Amps. Both views automatically refresh about every 15 seconds.

DETAILS

SUMMARY VIEW

The Summary page (figure 1) presents information at the array level. The button across the top “Lock/Unlock Whole Station” allows you to disable commands to the system. This is useful as a safety precaution when servicing the station. To the right is the time the information your viewing was last updated. This is based on your local computer’s time. The strings are organized around the physical and logical layout as closely as possible and list the status of the module, on or off, and status of the Maximize Power Point feature, MPP, on or off. Clicking on the string and module area will take you to the String View.

Below the string and module area is a bar chart showing the power output for each string in the array. The power output details for the array are shown on the right edge; including estimated kW hours. At the bottom is a graph of Energy, power and temperature. The scale for the temperature is listed on the right edge of the graph. You can position your mouse over the lines to see the time and value of the measurement. The time scale of the graph can be changed using the controls to the right of the graph. You can change the time interval as well as go back and forward time periods.

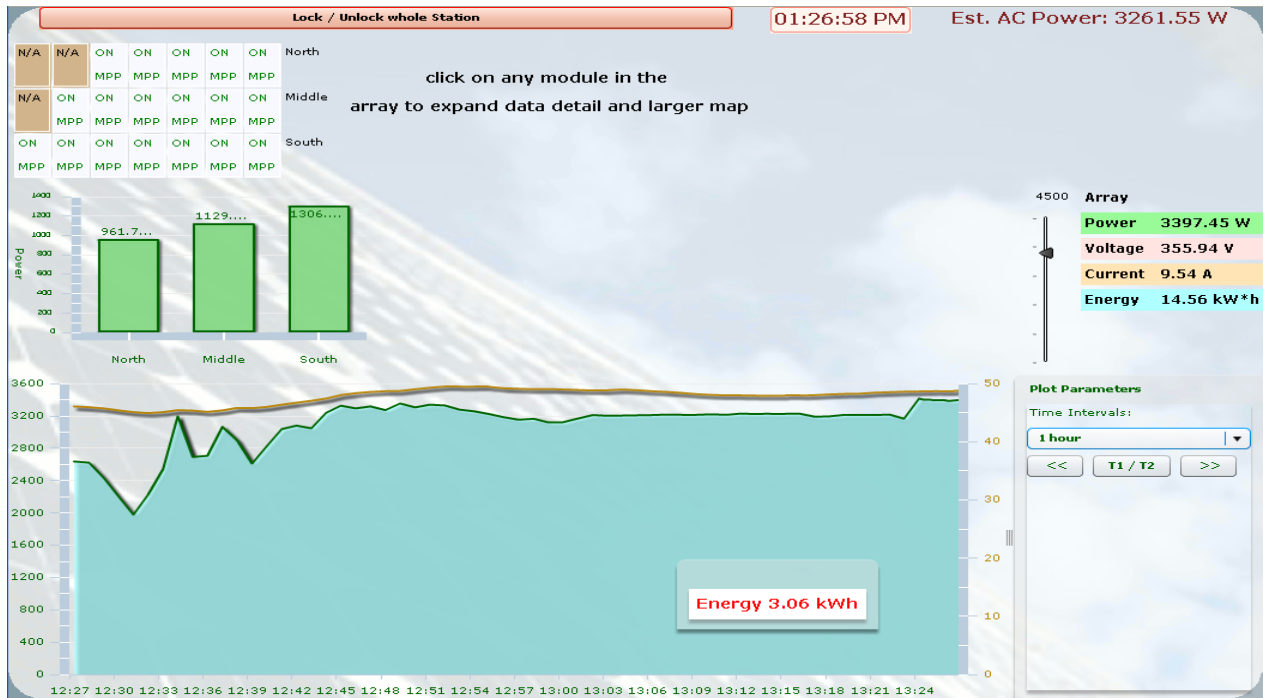

FIGURE 1

STRING VIEW

Similar to the Summary view, the strings are organized around the physical and logical layout as closely as possible. In String view the status of the module is shown in detail. There's a legend on the next page that covers the meaning of different background colors.

- MaxPower – Maximum power output from Solar Module with SPT Technology
- Vmp-IN – Voltage output from SPT Module
- I-Out – Amps output from SPT Module
- V-Out – Solar Module voltage output
- Temp – Temperature inside the SPT Module
- OverV – Over Voltage setting for SPT Module
- Mod ON – SPT Module status (on/off)
- Mpp ON – Maximize Power Point Technology status (on/off)
- ID – Unique identifier for the SPT Module

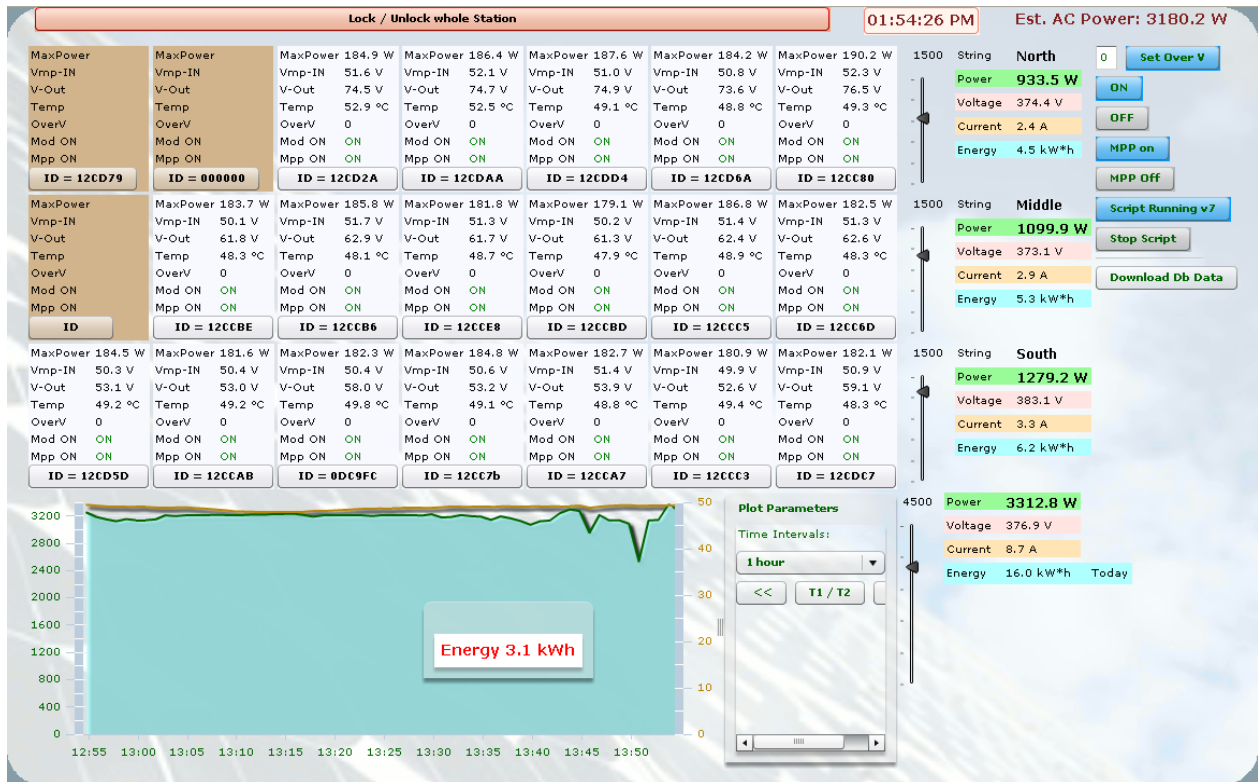

FIGURE 2

To the right of the string layout is Power output details for each string; Power, Voltage, Current, and Energy. There are multiple controls on the far right edge.

- Set Over V – Set Over Voltage limit for all the SPT Modules.
- ON – Turns the SPT Module *on* allowing current and voltage to pass through device.
- OFF - Turns the SPT Module *off* blocking current and voltage output.
- **WARNING** *** Module is still producing voltage and looking for a pathway to ground. ***
- MPP ON – Enable the Maximize Power Point feature of the SPT Module
- MPP OFF – Disable the Maximize Power Point feature of the SPT Module
- Download Db Data – Download the data that is currently being viewed in the graph at the bottom.

GUI LEGEND

The SPT module background color varies based on the power output of the module.

MaxPower 1.0 W	MaxPower 75.4 W	MaxPower 88.4 W	MaxPower 139.1 W	MaxPower 164.4 W
Vmp-IN 41.8 V	Vmp-IN 34.5 V	Vmp-IN 33.6 V	Vmp-IN 35.2 V	Vmp-IN 34.3 V
V-Out 50.2 V	V-Out 49.7 V	V-Out 35.7 V	V-Out 49.2 V	V-Out 48.7 V
I-Out 0.0 A	I-Out 2.1 A	I-Out 2.4 A	I-Out 3.9 A	I-Out 4.7 A
Temp 30.5 °C	Temp 37.6 °C	Temp 37.7 °C	Temp 30.4 °C	Temp 34.5 °C
V Limit 220	V Limit 220	V Limit 220	V Limit 220	V Limit 220
I Limit 200	I Limit 200	I Limit 200	I Limit 200	I Limit 200
Mod ON ON	Mod ON ON	Mod ON ON	Mod ON ON	Mod ON ON
Mpp ON ON	Mpp ON ON	Mpp ON ON	Mpp ON ON	Mpp ON ON
1309K000150	1309K000319	1309K000194	1309K000118	1309K000325

0 to 39.9 W

40 to 79.9

80 to 119.9 W

120 To 159.9 W

Over 160 W

A reddish background means SPT is not talking to the gateway and field computer.
ie. No data is being captured for that module.

MaxPower 0.9 W	MaxPower 1.0 W
Vmp-IN 41.1 V	Vmp-IN 41.1 V
V-Out 50.5 V	V-Out 50.7 V
I-Out 0.0 A	I-Out 0.0 A
Temp 32.0 °C	Temp 33.4 °C
V Limit 220	V Limit 220
I Limit 200	I Limit 200
Mod ON ON	Mod ON ON
Mpp ON ON	Mpp ON ON
1309K000143	1309K000254

Brown indicates that a module position is reserved GUI but no SPT installed.

MaxPower
Vmp-IN
V-Out
I-Out
Temp
V Limit
I Limit
Mod ON
Mpp ON
ID

DATA BASE AND TREND ANALYSIS

COMPLETE SYSTEM LAYOUT AND WIRING DIAGRAM

SPT Module and String Connections

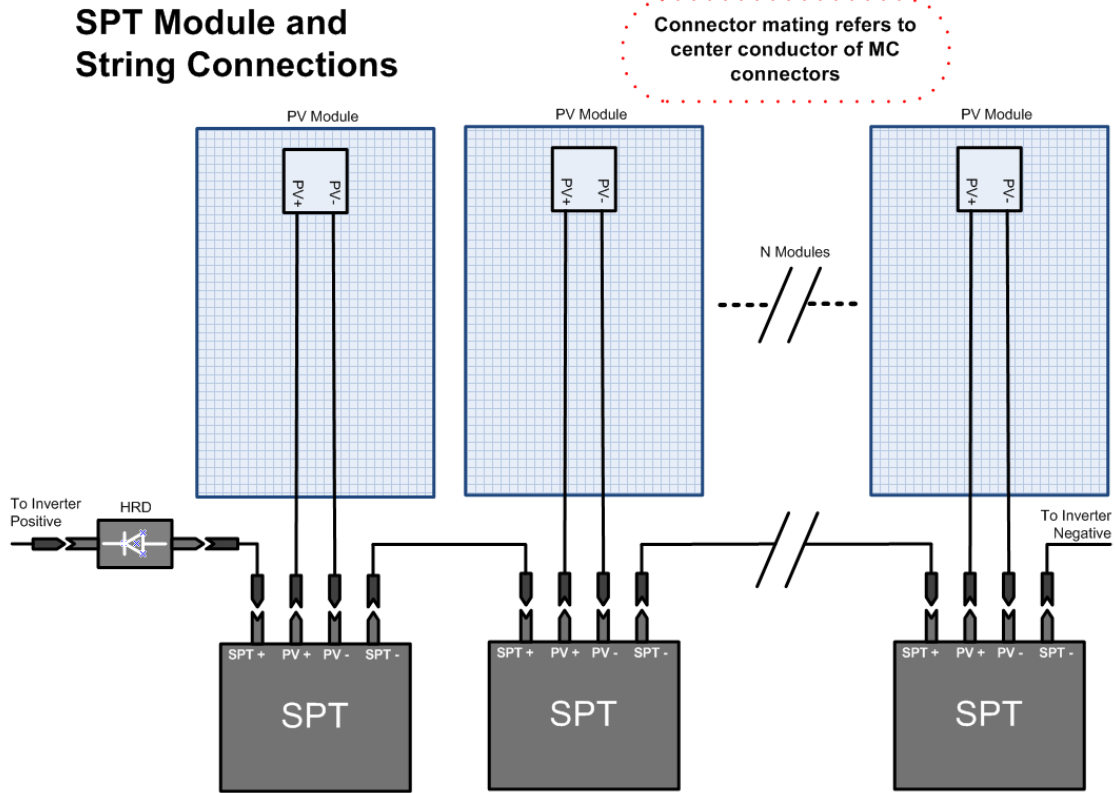

COMMUNICATION SYSTEM LAYOUT

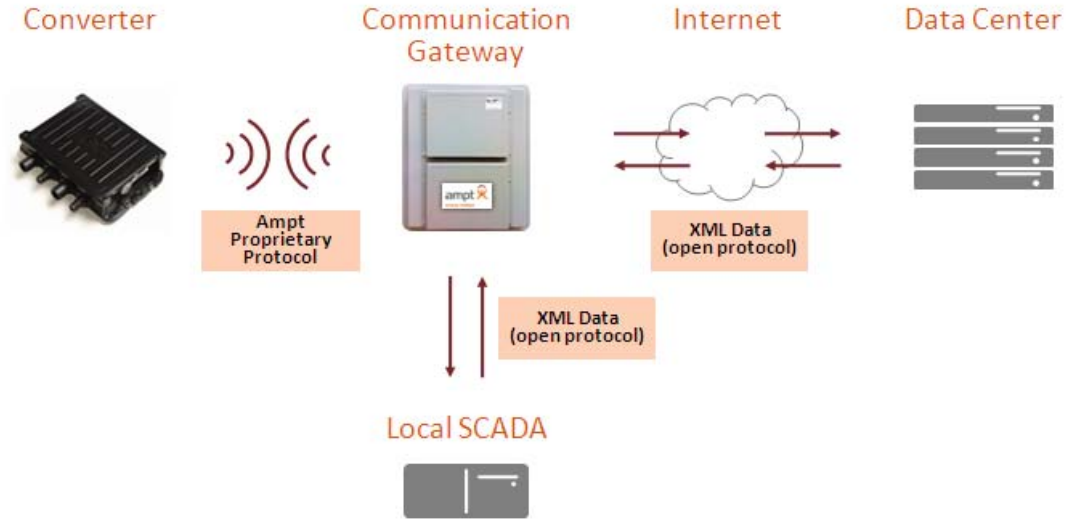

DESIGNING YOUR SPT SYSTEM SOLUTION

ORDERING INFORMATION – SAMPLE SALES ORDER

QUICK INSTALL GUIDE

For those who already know the basics and just want to get going.

INSTALLATION SEQUENCE OF EVENTS

1. Unpacking and inspection
 2. Proper system grounding prior to installation
 3. Installation of the field computer
 - a. Mounting
 - b. AC Power
 - c. Internet connection via Ethernet
 - d. Connection to the Gateway
 - e. Connection to a laptop
 4. SPT mounting and mechanical
 - a. Mounting choices
 - i. Plane of array
 - ii. Perpendicular to plane of array
 - iii. Other
 - b. Installing the SPT to the bracket
 - c. Installing the bracket to the mounting structure
 - i. Hardware and torques
 - ii. Grounding
 - d. Using the handheld device to record serial numbers
 5. HRD mounting and mechanical
 6. Electrical connections and communication with handheld
 - a. Proper connection with MC connectors
 - b. Module to SPT
 - i. Establishing contact with the handheld device
 - ii. Turning on the SPT
 - iii. Measuring module characteristics
 - iv. Turning off the SPT
 - c. SPT to SPT Cabling
 - d. SPT to HRD box
 - e. Cable handling and securing
 7. Graphical User Interface
-

UNPACKING AND INSPECTION

- Carefully unpack and inspect each SPT, HRD and cable for damage.
- Inspect each field computer for damage
- Inspect each MC connector before making any electrical connections. Proper connectors should be clean and free from damage. Insert pictures here.

PROPER SYSTEM GROUNDING

INSTALLATION OF THE FIELD COMPUTER

- a. Mounting
 - b. AC Power
 - c. Internet connection via Ethernet
 - d. Connection to the Gateway
 - e. Connection to a laptop
-

SPT MOUNTING AND MECHANICAL

- Mount and ground racking or support structure per NEC Article 690 and manufacturer's instructions. Ensure that support structure is grounded before mounting modules or SPTs

Planning

- Use only stainless steel fasteners to secure the SPT bracket to the mounting structure
- Choose flat brackets or "L" brackets for the installation.
- Insert the SPT in the bracket by pushing until the pushpin holes align
- Install mounting push pins
- Plan to mount SPT at least one inch (2.5 cm) from the back of the module surface to allow for adequate cooling air flow.
- Plan to mount SPT, module cables, and SPT connection cabling in a location that will not be subject to physical damage, and will not be subject to snow or other debris slides. (reword)

Mounting into rails with 3/8 or 1/4 slots

If mounting to a structure with rail slots, insert 3/8 or 1/4 inch hardware in the rail slot before modules or “L” feet or stanchions are secured. Each SPT requires two bolts, two nuts, two flat washers, and two lock washers. Whizz nuts are not recommended as the galvanized coating of the bracket may be compromised.

Secure each bracket, making sure that each lock washer is fully compressed. Torque 3/8 inch fasteners to XXX inch-pounds and 1/4 inch fasteners to YYY inch-pounds.

Mounting into rails or braces without slots

Check with racking or module support manufacturer for suggested mounting procedure.

Check with a local structural engineer and/or the racking manufacturer if any modifications to the structure (ie. Drilling holes)

Use the bracket as a guide for any pre-drilled holes.

Insert 3/8 or ¼ inch hardware in the rail slot. Each SPT requires two bolts, two nuts, two flat washers, and two lock washers. Whizz nuts are not recommended as the galvanized coating of the bracket may be compromised.

Secure each bracket, making sure that each lock washer is fully compressed. Torque 3/8 inch fasteners to XXX inch-pounds and ¼ inch fasteners to YYY inch-pounds.

HRD Mounting and Mechanical

Electrical connections and communication with handheld

Mount and ground module per module manufacturer’s instructions.

Connect the module leads to the SPT

Inspect MC connector for water tight seal

Establish communication with the handheld unit.

Place SPT in “On” mode.

- Check module V_{oc} for temperature and irradiance adjusted value from module nameplate reading.
 - Place SPT in “Off” mode
 - Repeat for next SPT’s in string
 - Connect SPT-SPT cable.
 - Secure module and SPT-SPT cables to support structure or module frame with UV rated wire ties and/or stainless steel clips or strain relief
-
-

- f. Mount each SPT as each module is installed. Modules performance may be tested with the SPT as each module is installed.
- g. Choose to mount the SPT’s either parallel, perpendicular, or in a fashion that takes advantage of the module support structure. The SPT is supplied with a flat and an “L” shaped bracket. Brackets have 3/8” and 1/4” pre-drilled to the plane of the array.
- h.
- i. Mounting choices
 - i. Plane of array
 - ii. Perpendicular to plane of array
 - iii. Other
- j. Installing the SPT to the bracket
- k. Installing the bracket to the mounting structure
 - i. Hardware and torques
 - ii. Grounding

SPT INSTALLATION

MECHANICAL MOUNTING SPT TO THE PV MODULE

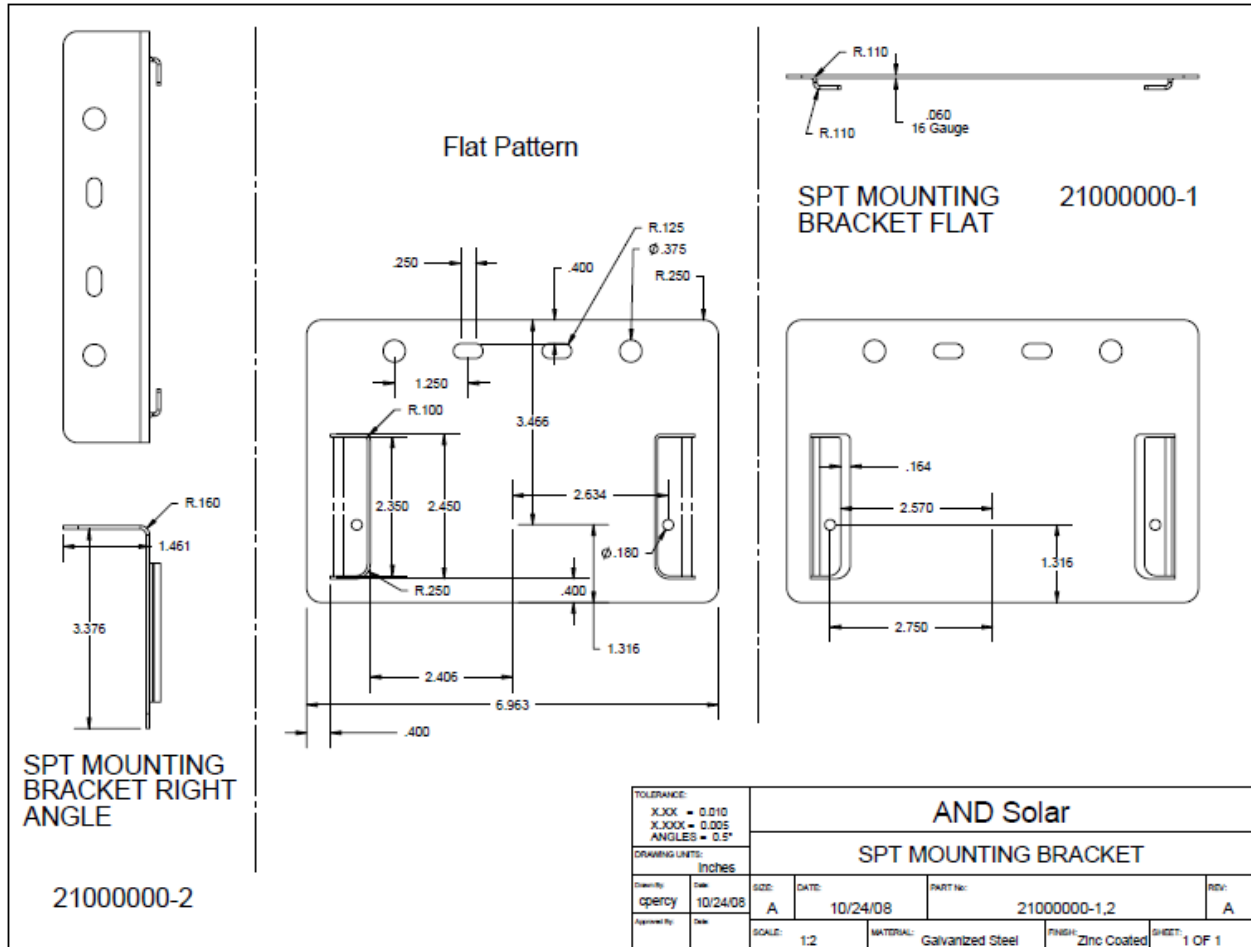

RACKING SYSTEMS

MOUNTING DIRECTLY

USING FLAT OR L PLATE

WIRING SPT TO THE PV MODULE

COMPLETING THE STRING WIRING

HRD INSTALLATION

MECHANICAL MOUNTING THE HRD

WIRING THE HRD

COMPLETING THE HOME RUN WIRING

GATEWAY AND FIELD COMPUTER

LOCATION DETERMINATION

SYSTEM REQUIREMENTS

AC POWER

INTERNET ACCESS

MECHANICAL MOUNTING

ELECTRICAL WIRING

SPT SYSTEM COMMISSIONING

MAPPING YOUR SYSTEM

USING THE HAND HELD FC

POWER UP AND DOWN

READING THE DISPLAY

TURNING MODULES ON AND OFF

RECORDING SERIAL NUMBERS

DOWNLOADING DATA

POWER UP THE FC

VERIFY GATEWAY OPERATION

TESTING THE SIGNAL STRENGTH TO THE GATEWAY

ACCESSING THE FC THROUGH THE INTERNET

SETTING UP THE GUI

DEFINING USERS AND ADMINISTRATIVE FUNCTIONS

CHOOSING THE USER DEFINED PARAMETERS

ALERT THRESHOLDS

SCRIPT CHOICES

INSTALLATION MODE

COMMERCIAL OPERATION MODE

RESIDENTIAL OPERATION MODE

UTILITY OPERATION MODE

MAINTENANCE MODE

SUMMARY PAGE

MAPPING OUT YOUR ARRAY

CROSS CHECKING YOUR MODULE POSITIONS

SETTING UP THE DATA BASE

OPERATING INSTRUCTIONS

READING THE GUI

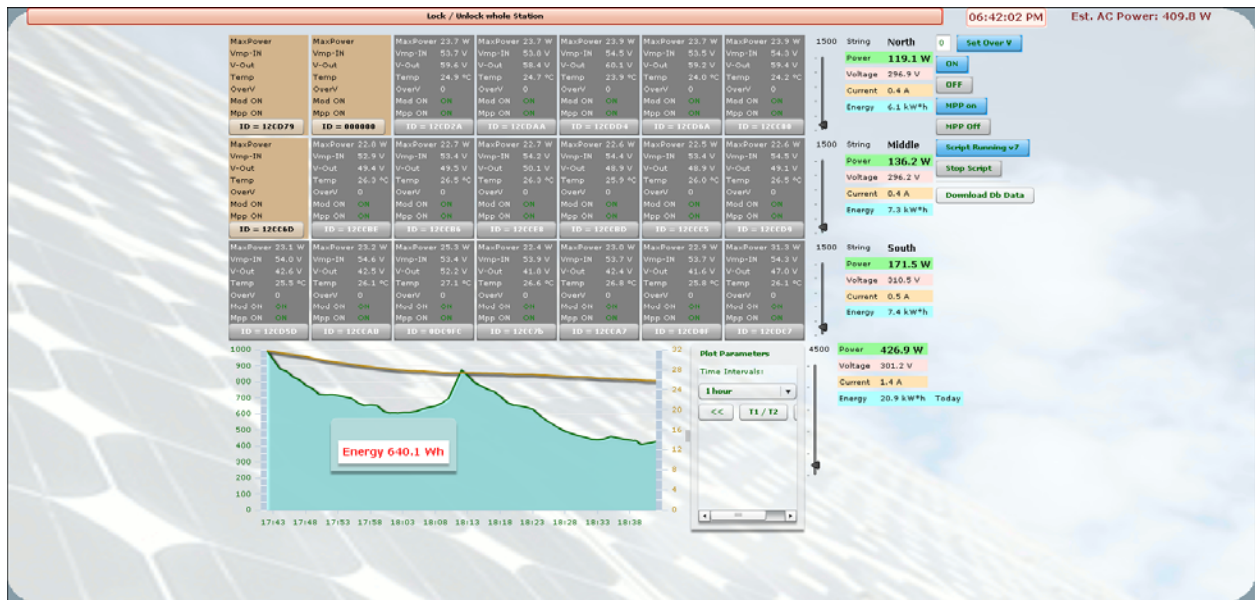
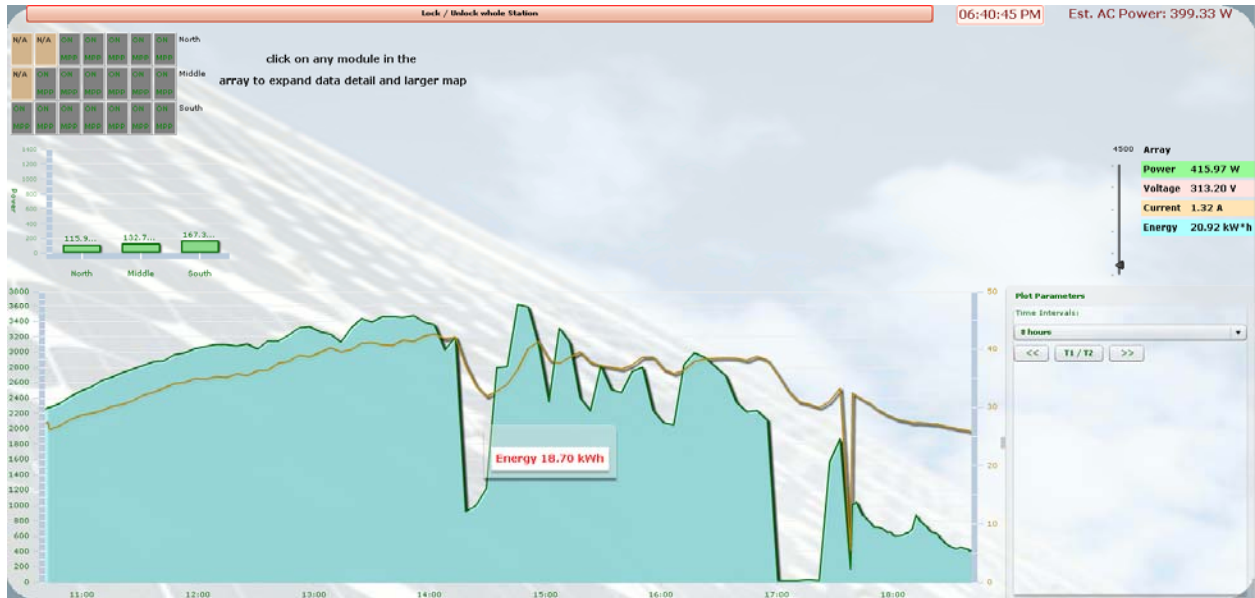



CONTROL FEATURES

NORMAL OPERATION

WHAT YOU SEE

HOW TO INTERPRET

HOW TO MODIFY

ACCESSING THE DATA BASE

SORTING THE DATA

DEFINING USER TEMPLATES

INTERPRETING ALERT MESSAGES

TROUBLESHOOTING

SPT OPERATIONAL ISSUES

GUI OPERATIONAL ISSUES

TECHNICAL DATA

SPT SPECIFICATIONS SHEET

	Pilot Units - 72 cells 31570001-00 SPT UNIT WITH MC3	Pilot Units - 72 cells 31570001-01 SPT UNIT WITH LC3
Model number	31570001-00	31570001-01
Description	SPT UNIT WITH MC3	SPT UNIT WITH LC3
DC – DC Conversion		
Max. input DC power	240W	240W
MPP range	20.6V - 51V	20.6V - 51V
Max. DC input voltage	56 VDC	56 VDC
Max. DC input current	7.5 ADC	7.5 ADC
Max. DC output current	7.5 ADC	7.5 ADC
Programmable Max Output Voltage Range	24V - 55V	24V - 55V
Programmable Max Output Current Range	3A - 7.5A	3A - 7.5A
Typical Efficiency	> 98.5%	> 98.5%
Max. Efficiency	99.2%	99.2%
General data		
Safety compliance	CSA to UL 1741	CSA to UL 1741, CE
EMI	FCC Class A	FCC Class A
DC reverse polarity protection	YES	YES
Connections	MC3 chassis receptacle	LC3 chassis receptacle
Ambient temperature (Operating range)	-40°F - +122°F (-40°C - +50°C)	-40°F - +122°F (-40°C - +50°C)
Cooling	Convection	Convection
Enclosure type	IP65	IP65
Calculated MTBF (Telcordia SR-332, Issue 2, Method1, Case1)	2.03M Hours	2.03M Hours
Specifications		
Dimensions (excluding connectors)	5.9" x 3.7" x 1.1"	5.9" x 3.7" x 1.1"
Weight	11 oz	11 oz
Warranty	25 years	25 years

SPT PHOTO & MECHANICAL DRAWING

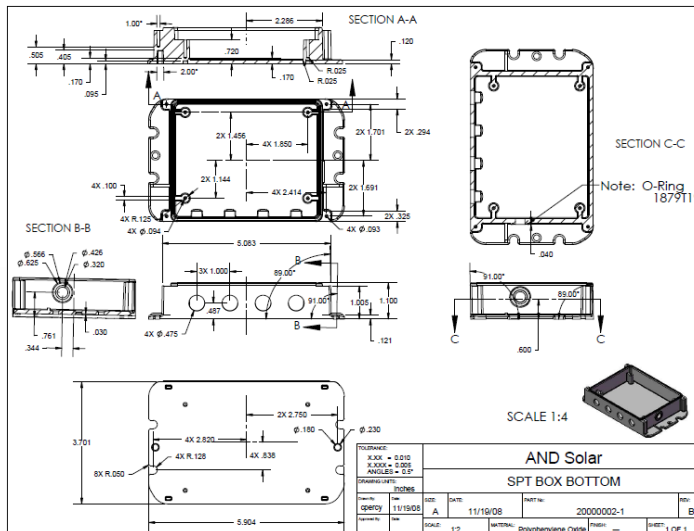

HRD SPECIFICATIONS SHEET

Model number	31570011-00	31570011-01
Description	HRD UNIT WITH MC3	HRD UNIT WITH LC3
Rated Voltage	600 Volts	600 Volts
Rated Current	12 Amps	12 Amps
General data		
Safety compliance	CSA to UL 1741, CE	CSA to UL 1741, CE
Connections	MC3 chassis receptacle	LC3 chassis receptacle
Ambient temperature (Operating range)	-40°F - +122°F (-40°C - +50°C)	-40°F - +122°F (-40°C - +50°C)
Cooling	Convection	Convection
Enclosure type	IP65	IP65
Specifications		
Dimensions (excluding connectors)	2.9" x 1.2" x 1.0"	2.9" x 1.2" x 1.0"
Weight	11 oz	11 oz
Warranty	25 years	25 years

HRD ILLUSTRATION



HRD MECHANICAL DRAWING

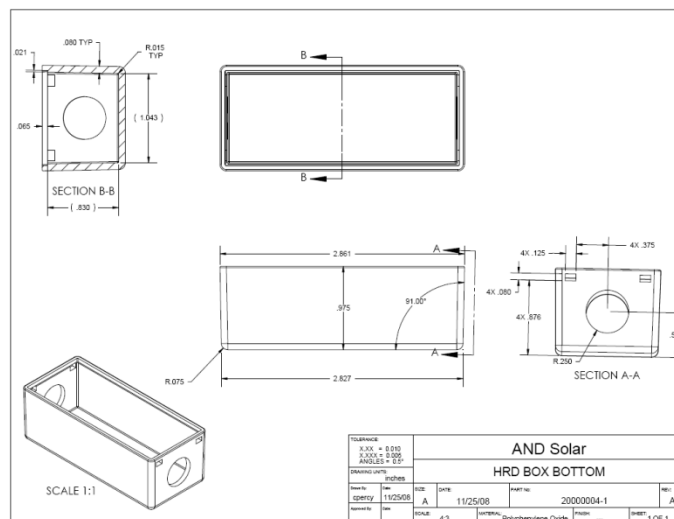

FC SPECIFICATIONS SHEET



Manufactured by DMP Electronics Inc

- Model eBox-3300
- CPU MSTI PDX-600 (1GHz)
- Memory Onboard 256MB DDR2
- Graphics XGI Z9s with 32MB DDR2
- External 15-pin D-type female VGA connector
- Ethernet Integrated 10/100 Mbps LAN
- Built-in PXE diskless boot function
- 2nd Ethernet chip Realtek RTL8100B 10/100
- Base-T Ethernet (optional)
- I/O 44pin IDE x 1
- Micro SD x 1
- CF Slot x 1
- USB Port x 3 (2 in front)
- RJ-45 x 1
- PS/2 x 1 Keyboard/Mouse shared
- Mini PCI Socket x 1 (optional)
- RS232 x 2 (optional)
- Audio Mic in and Line out
- Power +5V @ 2A (10 W)
- Dimensions 115 x 115 x 35 mm
- Weight 505g

HAND HELD FC SPECIFICATIONS SHEET



Manufactured by Motorola

Physical Characteristics

- Dimensions: 6 in. L x 3.3 in. W x 1.7 in D (15.24 cm L x 8.4 cm W x 4.4 cm D)
- Weight (including Standard 1.5X battery: 14.9 oz./422 g)
- Display: Transflective color 640 x 480 3.5" full VGA with backlight
- Touch Panel: Glass analog resistive touch
- Backlight: LED backlight
- Main Battery: Rechargeable Lithium Ion 3.7V, 3600 mAh Smart Battery
- Expansion Slot: microSD slot (maximum 2 GB)
- Network Connections: Ethernet (via cradle); full-speed USB, host or client
- Notification: Vibrator and LED
- Keypad Options: 26-key Numeric; 44-key QWERTY
- Audio: Speaker, receiver, microphone, headset jack

Performance Characteristics

- CPU: XScale™ PXA270 624 MHz processor
- Operating System: Microsoft® Windows Mobile® 6.0
- Memory: 128MB RAM; 256MB Flash
- Interface: RS-232, USB 1.1

User Environment

- Operating Temperature: 14° F to 122° F/-10° C to 50° C
- Storage Temperature: -40° F to 140° F/-40° C to 60° C (w/o battery)
- Humidity: 95% non-condensing
- Drop Specification: 5 ft. drop to concrete, at ambient temperature 73° F/23° C;
- Sealing: IP54
- IrDA: Integrated
- Clock: Integrated real time clock

Baseline features:

- Each Hand Held Computer will be capable of communicating with the SPT/IJB and Field Computer throughout the expected 20 years in a typical installation lifetime
- WWAN Radio: GSM: 3G HSDPA; CDMA: EVDO Rev A
- GPS: Integrated Assisted-GPS (A-GPS)
- WLAN Radio: Tri-mode IEEE® 802.11a/b/g
- Color Camera Resolution: 2 megapixel

- Electrical Safety: Certified to UL / cUL 60950-1, IEC / EN60950-1
- FCC Class B EMI Certified
- Environmental: RoHS-compliant

GUI PARAMETERS AND SYSTEM REQUIREMENTS

TECHNICAL SUPPORT

By choosing an Ampt product, you have also chosen comprehensive technical support & service. In order to attend to your needs in as flexible a manner as possible, we offer you the following services:

- The Ampt Technical Support & Service Phone Hotline: 970-372-6947
- Replacement service: 970-372-6950
- On-site service: 970-372-6950
- Comprehensive warranty program

With this offer you enjoy a definitive advantage: Ampt supports you from the initial planning phase onward – and, of course, during the entire operating time of the PV system.

In order to better assist you when contacting Ampt, please provide the following information. This information is required for service assistance.

INFORMATION REGARDING THE SPT:

- Serial number
- Model Number
- Short description of the problem
- Blinking Code or display message
- What error code is indicated via the Ampt GUI?
- DC line voltage
- Can you reproduce the failure? If yes, how?
- Has this problem occurred in the past?
- What were the ambient conditions when the problem occurred?

INFORMATION REGARDING THE PV MODULES:

- Manufacturer name and model number of the PV module
- Output power of the module
- Open circuit voltage (Voc) of the module
- Number of modules in each string

LIMITED WARRANTY

The Ampt SPT is warranted against defects in workmanship and materials for a period of 1 year from date of shipment, provided that the product remains unmodified and is operated under normal and proper conditions.

The Ampt SPT 25 year operational warranty covers any repair or replacement part costs incurred during the agreed period, beginning on the device's purchase date, subject to the conditions listed below.

WARRANTY CONDITIONS

If an Ampt SPT device becomes defective during the 25 year Ampt warranty period, one of the following services, as selected by Ampt, will be performed at no charge for materials or labor costs:

- Repair at Ampt, or
- Repair On-Site, or
- Exchange for a Replacement Device

In the case of an exchange, the remainder of the warranty eligibility will be transferred to the replacement device.

Ampt generally will provide an equivalent replacement device, packaged appropriately for transport, within 48 hours. The defective device is to be packed in this transport packaging for return transport to Ampt.

EXCLUSION OF LIABILITY

Warranty claims and liability for direct or indirect damage are excluded if arising from:

- Transport Damage,
- Incorrect Installation or Commissioning,
- failure to Observe the Maintenance Regulations and Intervals,
- Modifications, Changes or Attempted Repairs,
- Incorrect Use or Inappropriate Operation,
- Insufficient Ventilation of the Device
- failure to Observe the Applicable Safety Regulations,
- force Majeure (e.g. lightning, overvoltage, storm, fire), or
- Cosmetic Shortcomings (which do not influence the supply of energy)

Further-reaching or additional claims due to direct or indirect damage, including claims for compensation for damages due to loss of profits or due to costs arising from disassembly and mounting, are excluded.

FOR WARRANTY RETURNS & INSTALLER REPLACEMENT:

Ampt will compensate installers for expenses associated with replacing SPT products under warranty per the following registration and warranty process:

1. Installer must contact the technical support team at Ampt to register the support issue and seek assistance. Ampt Technical support will provide troubleshooting assistance and is committed to resolving the claim in one of the following ways;
 - a. Situation will be resolved to the installer's satisfaction over the phone or via the Ampt wireless communication link to the SPT
 - b. Ampt or one of the Ampt certified field service technicians will be dispatched to the site for additional troubleshooting and repair of the SPT
 - c. Ampt will determine that the unit should be replaced and will provide the installer with an RMA number to proceed with warranty replacement of the unit
2. Once the RMA number has been issued by Ampt, there are two options;
 - a. The installer can use an existing unit from inventory to replace the failed SPTor
 - b. Ampt can send out an advance replacement unit
3. In either case, the replaced unit must be returned to Ampt for issue confirmation, root cause analysis and corrective action planning
4. Any exceptions to this process must be approved in advance by an authorized Ampt representative

APPENDIX:

FAQ

INSTALLATION MAPPING

WIRING DIAGRAMS

ORDERING SPARE OR REPLACEMENT PARTS

RETURN PROCEDURES

WHITE PAPERS

1. Robust Large Scale PV Systems Having Distributed DC/DC Conversion – By Robert Porter
Proper transfer function to achieve stable, predictable, and reliable operation

PRESENTATIONS