



Ampt String Optimizer V1500 Series

Installation Manual

57070012-1 v20180705



Copyright 2018 Ampt, LLC. All rights reserved. No part of this document may be reproduced, retransmitted, or copied in any form without the expressed and written permission of Ampt, LLC.

This document contains information needed to install and commission an Ampt optimizer (including Smart String Technology™ optimizers, String Stretch® optimizers, Ampt Mode® optimizers, String View® optimizers, V-match™ optimizers, I-match™ optimizers, Direct-to-Battery™ optimizers, and Direct-to-Converter™ optimizers) within a photovoltaic (PV) installation.

U.S. and international patents apply to this product. For details visit: www.ampt.com/patents.

Read This First

To help avoid problems during the system installation, familiarize yourself in advance with the installation process by reading this entire document before starting the installation.



Risk of electric shock, do not remove covers. No user serviceable parts inside. Refer servicing to qualified service personnel. When the photovoltaic array is exposed to light, it supplies a dc voltage to this equipment.



Le risqué de décharge électirque n'enlèvent pas la couverture. Aucunes pieces utiles d'utilisateur à l'intérieur. Référéz-vous l'entretien au personnel de service qualifiè. Quand la range photovoltaïque est exposée à la lumière. Il fournit une tension CC à cet équipement.



Hot surfaces – to reduce the risk of burns – do not touch.



Les surfaces chaudes - pour réduire le risque de brûlures - ne se touchent pas.

IMPORTANT SAFETY INSTRUCTIONS

This manual contains important instructions for Ampt optimizers that shall be followed during installation and maintenance. The optimizer has been designed and tested according to international safety requirements, but requires certain precautions are observed when installing and/or operating the optimizer. To reduce the risk of personal injury and to ensure the safe installation and operation of the optimizer, please be sure you carefully read and follow all instructions and safety messages in this manual.

SAVE THESE INSTRUCTIONS

Safety Message Types

The following messaging is used to identify a hazard to equipment or personnel:



DANGER

Indicates a hazardous situation which, if not avoided, will result in death or serious injury.



WARNING

Indicates a hazardous situation which, if not avoided, could result in death or serious injury.



CAUTION

Indicates a hazardous situation which, if not avoided, could result in minor or moderate injury.

NOTICE

Indicates information considered important but not hazard, or personal injury, related - for example, property damage.

General Safety

Installation and maintenance should be performed only by qualified persons. Installers and maintenance personnel assume the risk of all injury that might occur during installation or maintenance including, without limitation, the risk of electric shock. Follow your safety procedures and protocols.

All electrical installations must be done in accordance with the local and National Electrical Code ANSI/NFPA 70; Canadian Electrical Code, Part I; or the applicable standards, codes, and regulations for your region.

The Ampt product contains no user-serviceable parts. All repairs and maintenance should be handled in accordance with the instructions and terms contained in the product warranty.

Before installing or using the Ampt optimizer, read all instructions and safety messages-on the optimizer and in this manual. Follow the safety precautions for this product as well as the other components in the PV system.

PV modules produce electrical energy when exposed to light and thus can create an electrical shock hazard. Wiring of the PV modules should only be performed by qualified personnel.

Disclaimer of Liability

Ampt makes no representations, expressed or implied, that with respect to this documentation or any of the equipment and/or software it may describe, including (with no limitation) any implied warranties of utility, merchantability, or fitness for any particular purpose. All such warranties are expressly disclaimed. Ampt shall not be liable for any indirect, incidental, or consequential damages under any circumstances. (The exclusion of implied warranties may not apply in all cases under some statutes, and thus the above exclusion may not apply.)

The following information is subject to change without notice, even though every attempt has been made to make this document complete, accurate and up-to-date. Readers are cautioned, however, that Ampt reserves the right to make changes without notice and shall not be responsible for any damages, including indirect, incidental or consequential damages, caused by reliance on the material presented, including, but not limited to, omissions, typographical errors, arithmetical errors or listing errors in the content material.

WARNING

Any use of the Ampt String Optimizer that is not expressly authorized in this manual or associated documentation is expressly prohibited by Ampt. Ampt disclaims any responsibility or liability for such prohibited use.

Table of Contents

Read This First	3
IMPORTANT SAFETY INSTRUCTIONS	3
Safety Message Types.....	4
General Safety.....	4
Disclaimer of Liability.....	5
Chapter 1: Product Overview.....	9
General Description.....	9
Dimensional Drawings.....	11
Physical Overview	12
Bar Code Label.....	12
Specifications	13
Chapter 2: Planning Installation.....	15
Overview	15
Inputs	15
Acceptable Input Configurations.....	15
Acceptable Input Configurations Between Parallel Optimizers	15
Electrical Connections	16
Ungrounded PV Systems.....	16
Resistively Grounded PV Systems (positive or negative)	16
Fuse Sizes.....	16
DC-coupled Storage.....	17
Inter-row Shading Wiring Example.....	17
Cabling Connectors.....	18
Chapter 3: Installing the Ampt String Optimizer	19
Getting Started.....	19
Parts and Tools Needed.....	19
Mounting and Grounding the String Optimizer	20
Steps.....	20
Making Electrical Connections.....	21
Steps.....	22
Verifying Electrical Connections	25
Before Connecting the Optimizer Output in parallel to other circuits:.....	25
Verify Operational Currents and/or Output Power	25
Uninstalling an Optimizer.....	26
Steps.....	26

Unexpected Current Detected	27
What this means	27
Steps.....	27
Appendix	29
Compliance.....	29
Model Numbering System	29
Markings.....	30
FCC Compliance	31
RSS-GEN.....	31
Avis IC.....	32
RSS-GEN.....	32
Contacts.....	33

Chapter 1:

Product Overview

General Description

Ampt String Optimizers are DC/DC converters with multiple features that lower the cost and improve the performance of new and existing PV systems.

Dual MPPT per optimizer - Ampt String Optimizers put maximum power point tracking on each of its two input strings of PV modules. This mitigates or eliminates mismatch losses to deliver more energy under changing environmental and system conditions over the lifetime of the power plant.

String Stretch[®] – Ampt's patented String Stretch[®] technology puts voltage and current limits on the output of each optimizer which doubles the number of modules per string and allows for smaller conductor sizing per kilowatt delivered to save up to 50% on electrical BOS costs.

Ampt Mode[®] – Inverters with Ampt Mode[®] operate in a narrow input voltage range that is closer to the maximum system voltage. This allows the inverter to deliver a higher AC output voltage at the same current which raises the rated output power of the inverter to lower the inverter's cost per watt.

V-match[™] – Ampt's patented V-match[™] technology allows the output of our optimizers to match the DC bus voltage set by the inverter or battery while delivering full available power from the PV modules. This uniquely allows PV arrays with Ampt to automatically adapt to legacy or future power equipment to repower existing systems, upgrade inverters, deploy optimized DC-coupled storage systems, and other applications.

I-match[™] - Ampt's patented I-match[™] technology allows the PV array to automatically (or by command) match the desired current of the battery as determined by either the battery SoC or the EMS.

Direct-to-Battery[™] – Ampt String Optimizers include power management technology for DC-coupled energy storage systems (ESS). Our Direct-to-Battery[™] technology allows the optimizer, battery, and inverter to share the same DC bus without additional charging equipment dedicated to the battery. This feature enables storage systems with greater efficiency, flexibility, and scalability at a lower cost.

Direct-to-Converter™ – For DC-coupled energy storage systems, Ampt String Optimizers include Direct-to-Converter™ technology which allows the DC bus to operate at a higher fixed voltage. This increases the power density of both the battery charger and inverter to lower equipment cost per watt while increasing the solar+storage system efficiency.

High DC/AC – Ampt’s patented technology allows DC/AC ratios of 2:1 or more. This enables system owners to expand the DC power on existing systems without replacing inverters, combiners, or cables. It also opens design flexibility for new systems to optimize inverter utilization and cost per watt.

Wireless Communication – Ampt String Optimizers incorporate optional wireless communication to provide string-level data that is highly accurate, synchronous, and scalable to improve O&M, as well as enhanced controls for storage applications.

For more information on Ampt’s product features and applications, visit www.ampt.com.

Dimensional Drawings

The dimensions for the String Optimizer shown below are in millimeters and inches.

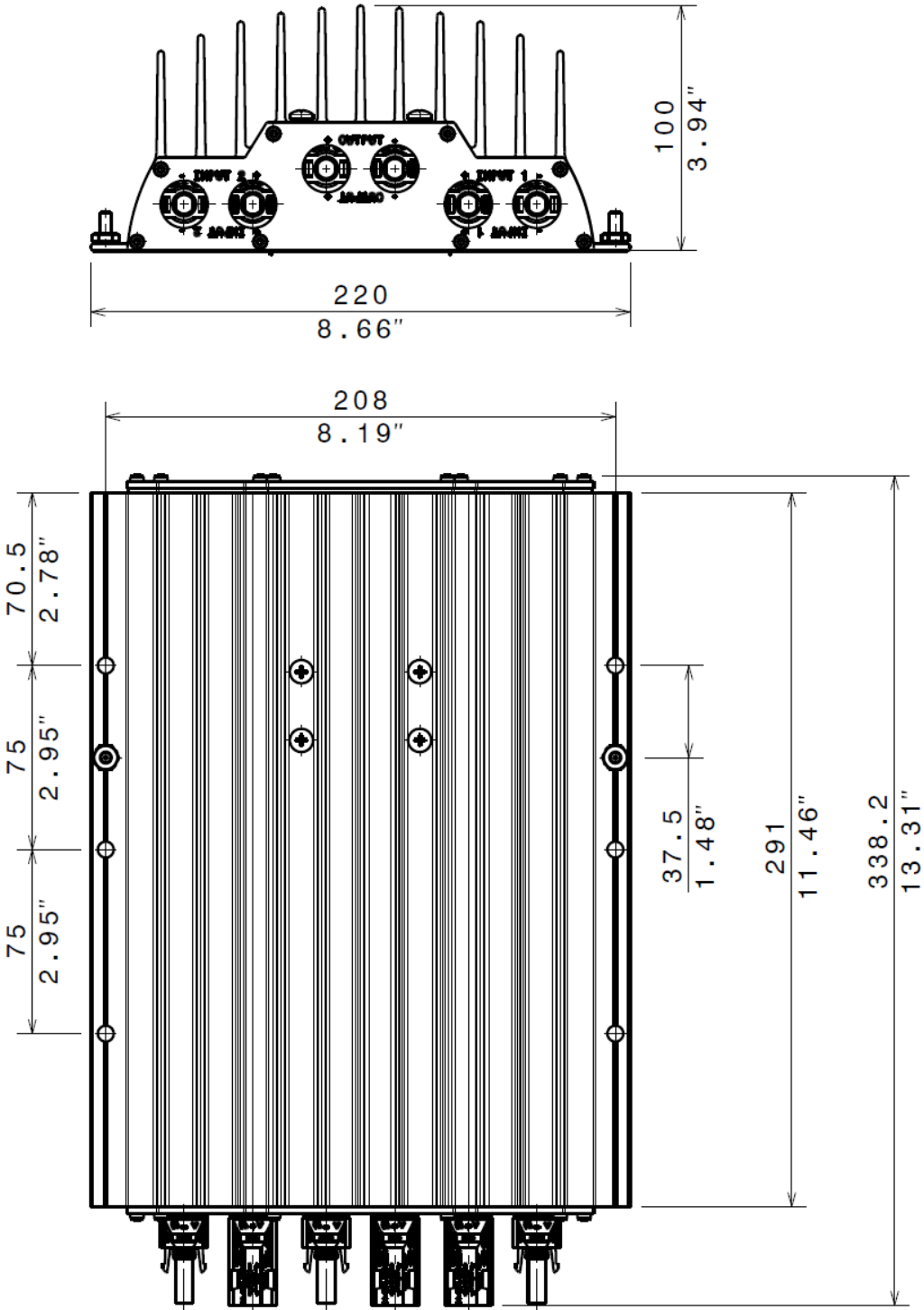

Figure 1: Dimensional drawings

Physical Overview

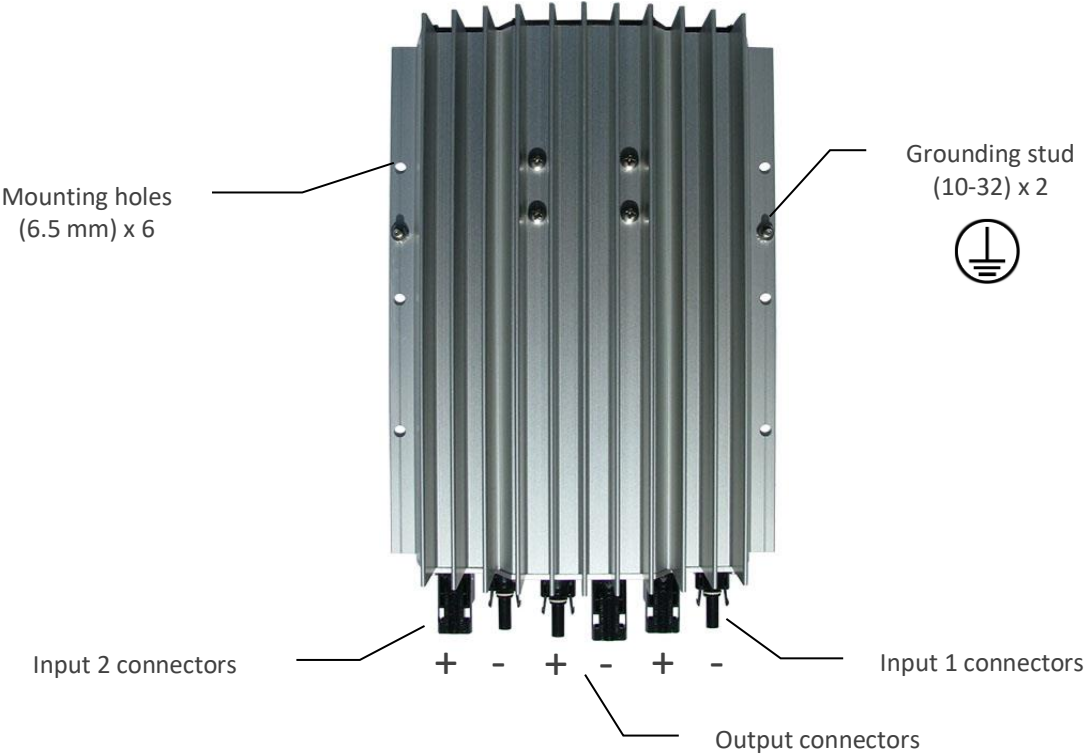

Figure 2: Physical overview of the string optimizer

Bar Code Label

The image below shows the bar code label with model and serial numbers.

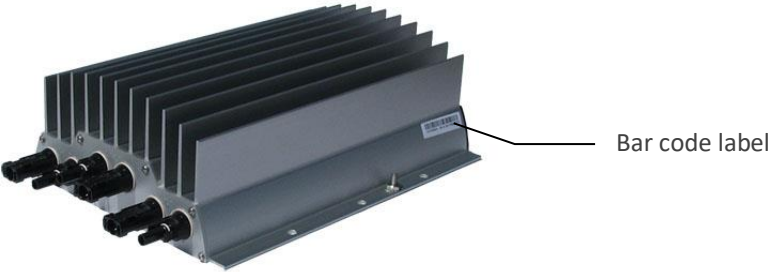

Figure 3: Bar code tag with the model and serial numbers

Specifications

		12A model	16A model	20A models	
		V1500-12	V1500-16	V1350-20	V1500-20
Electrical					
Input					
Maximum voltage per input ¹	V	1500	1500	1500	1500
Maximum current per input ²	A	12.3	12.3	12.8	12.8
MPP tracking voltage range	V	400 – 1300	400 – 1300	400 – 1300	400 – 1300
Number of inputs		2	2	2	2
Output					
Output voltage range	V	0 – 1500	0 – 1500	0 – 1350	0 – 1500
Maximum output current	A	12	16	20	20
Max continuous output power	kWdc	16.8	22.4	25.2	28
Efficiency (max, CEC, Euro)	%	99.6, 99.5, 99.4			
Mechanical					
Input & output connector		Amphenol H4			
Dimensions		13.46" x 8.66" x 3.94" (342 mm x 220 mm x 100 mm)			
Weight		13.6 lbs. (6.2 kg)			
Ambient temperature operating range		-40 °F to + 167 °F (-40 °C to +75 °C)			
Cooling		Convection			
Environmental					
Environmental category		Outdoor			
Pollution degree		2			
Maximum operating altitude ³		9843 ft (3000 m)			
Overvoltage category		OVII			
Ingress protection		IP 66/4X			
General					
Maximum system voltage		1500 V			
Compliance		ETL to UL 1741; IEC 61000-6-1, 61000-6-3, 62109; CE; Giteki 2-1-19; FCC Part 15, class A			

1. Voc at coldest design temp. - follow Ampt's design guidelines to determine the number of modules per input and max. system voltage.
2. Module Imp at standard test condition (STC) - irradiation level of 1000 W/m² at 25°C.
3. Optimizer derates above this altitude.

Chapter 2:

Planning Installation

Overview

This chapter defines the acceptable criteria for input connections, describes the appropriate electrical connections based on the grounding configuration of your PV system, and explains the mating connector polarities for the inputs and output of the String Optimizer.

Inputs

This section defines the acceptable criteria for the two input connections of the Ampt String Optimizer.

NOTICE

The inputs of the optimizer are not intended for connection to a battery or any other type of DC source except PV modules.

The following information applies to 60- or 72-cell c-Si/p-Si modules. If you are using another type of module (e.g. thin-film), please contact Ampt for configuration rules.

Acceptable Input Configurations

It is common for inputs 1 and 2 to have the same number of modules (i.e. $I_{n1} = I_{n2}$). However, if the number of modules between inputs is different, the following conditions must be met for the optimizer to operate at MPP.

$$V_{oc-cold-in1} \geq V_{oc-cold-in2}$$

$$V_{out}/2 < V_{mpp-in1} < V_{out}$$

$$V_{oc-cold-in1} \leq 1500V$$

$$V_{out}/2 < V_{mpp-in2} < V_{out}$$

$$V_{oc-cold-in1} \leq \text{Inverter maximum input voltage}$$

$$0.5 \times P_{in1} < P_{in2} < P_{in1}$$

Acceptable Input Configurations Between Parallel Optimizers

The number of modules on each input between parallel optimizers can vary within an array so long as they meet the criteria described in the *Acceptable Input Configurations* section.

Electrical Connections

The electrical connection of the String Optimizer is done after mounting and grounding the unit.

Ungrounded PV Systems

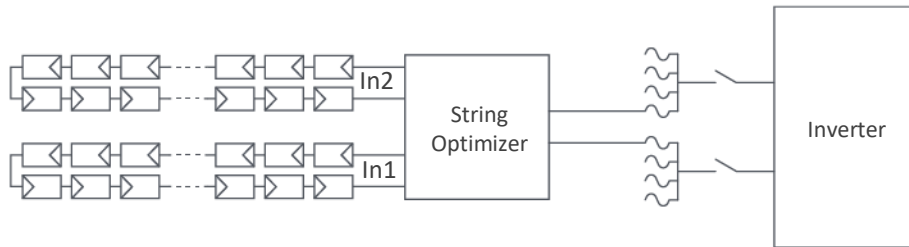

Figure 4: Electrical connections for an ungrounded PV system

Resistively Grounded PV Systems (positive or negative)

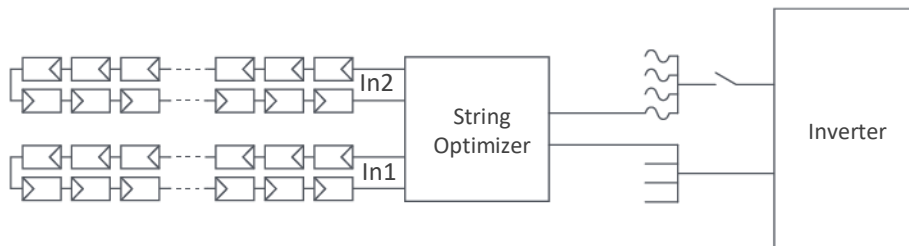

Figure 5: Electrical connections for a grounded PV system

Fuse Sizes

CAUTION

Over-current protection devices and conductors shall be sized in accordance with the National Electrical Code (ANSI/NFPA 70); Canadian Electrical Code, Part I; or the applicable standards, codes, and regulations for your region.

The output current limit of the Ampt String Optimizer eliminates the need for the 1.25 multiplication factor for over-sun conditions when calculating ampacity. The 1.25 multiplier for continuous use is still required.

Optimizer Max Output Current (A)	Minimum Fuse Size (A)
12	15
16	20
20	25

DC-coupled Storage

When used in DC-coupled storage applications, the optimizer does not function as a blocking diode.

Inter-row Shading Wiring Example

When inter-row shading is expected, the best practice is to wire the modules on the two inputs of the Ampt String Optimizer to be on the same row as shown below.

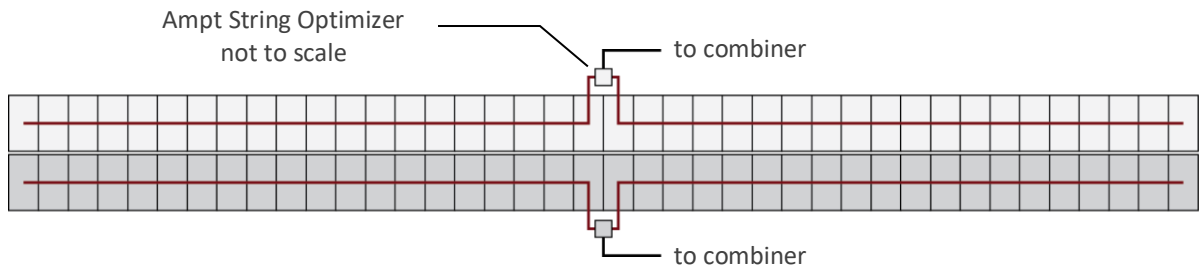

Figure 6: Wiring example when inter-row shading is expected

Cabling Connectors

The figure below shows the mating connectors and polarities for the inputs and output of the String Optimizer.

NOTICE
Use only Amphenol H4 mating connectors.

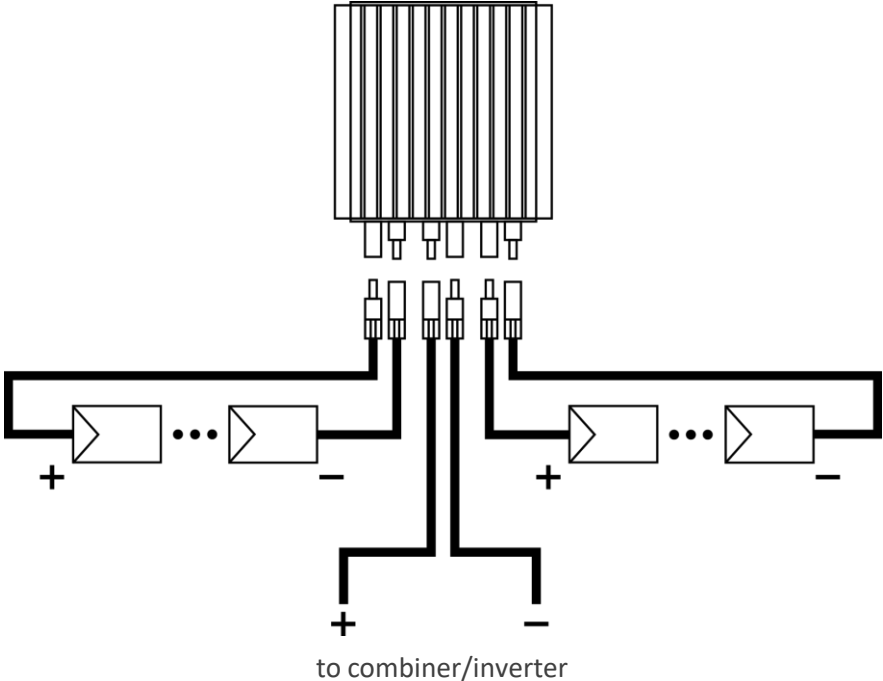

Figure 7: Mating connectors and associated polarity for the two inputs and the output of the String Optimizer

Chapter 3:

Installing the Ampt String Optimizer

Getting Started

This chapter addresses the proper mounting and installation of the Ampt String Optimizer. Read the entire chapter before starting the procedures and then conduct each task in the order given.

Parts and Tools Needed

- The mounting hardware varies by the type of PV module mounting rail.
- Amphenol H4 connector unlocking tool (Amphenol p/n: H4TR0000 or H4TU0000). Follow all safety practices when connecting and disconnecting PV connectors.
- General purpose anti-seize compound.
- Volt meter (rated for the PV system's maximum system voltage) with DC current clamp.

Mounting and Grounding the String Optimizer

WARNING

Read the warning statements below:

Installation and maintenance should be performed only by qualified persons. Installers and maintenance personnel assume the risk of all injury that might occur during installation or maintenance including, without limitation, the risk of electric shock. Follow your safety procedures and protocols.

All electrical installations must be done in accordance with the local and National Electrical Code ANSI/NFPA 70; Canadian Electrical Code, Part I; or the applicable standards, codes, and regulations for your region.

The Ampt optimizer is to be installed so that it is not expected to be contacted by persons.

CAUTION

Keep connectors dry and clean. Do not install Ampt String Optimizers in a location where they might be immersed in water.

Steps

1. Mount the String Optimizer to the rack using the mounting holes provided.
 - a. See *Dimensional Drawings* on page 11
 - b. The recommended practice is to mount the unit parallel to the PV modules with the connectors facing downward.
 - c. Ensure sufficient spacing such that the safety icons as well as the serial and model numbers on the bar code label can be read by maintenance personnel.
2. Ground the String Optimizer as required by your local codes using one of the grounding studs provided, or with a listed bonding washer.

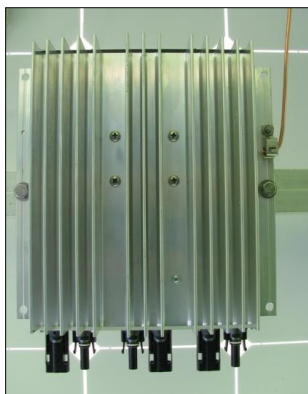

Figure 8: Ampt String Optimizer mounted and grounded

Making Electrical Connections

WARNING

Read the warning statements below:

Installation and maintenance should be performed only by qualified persons. Installers and maintenance personnel assume the risk of all injury that might occur during installation or maintenance including, without limitation, the risk of electric shock. Follow your safety procedures and protocols.

Do not make or break connections under load.

Ensure that there are no parallel connections to the string while series connections are being made.

Voltage may be present on the output terminals when an input terminal is connected.

Voltage builds as modules are connected in series.

CAUTION

Read the caution statements below:

To reduce the risk of fire, connect the outputs of the Ampt equipment only to conductors with sufficient ampacity based on the maximum output fault current (maximum optimizer output current) for the chosen optimizer. Over-current protection devices and conductors shall be sized in accordance with the National Electrical Code (ANSI/NFPA 70); Canadian Electrical Code, Part I; or the applicable standards, codes, and regulations for your region.

Over current protection is required for the DC output circuit in the installation.

Ampt recommends that a disconnect switch be included in the installation for the DC output.

NOTICE

Use only Amphenol H4 mating connectors.

NOTICE

Per Canadian Electrical Code, the installer is required to mark the device with the following wording or equivalent, located on or adjacent to each wiring compartment giving access to high voltage circuits, only if actually connected to high voltage in the installation:

DANGER — HIGH VOLTAGE

or

DANGER XXX V

where XXX is replaced by the rated voltage.

Steps

1. Read the warning, caution, and notice statements above.
2. The instructions that follow assume the PV system is using combiner boxes. Ampt supports the use of collection harnesses and other schemes that do not allow for isolation of individual optimizer output circuits. Please contact Ampt Support for alternate instructions.
3. Ensure the String Optimizer is mounted and grounded.
 - See *Mounting and Grounding the String Optimizer* on page 20.
4. Make sure you are familiar with the electrical connections for the String Optimizer in your system. See:
 - *Electrical Connections* on page 16.
 - *Cabling Connectors* on page 18.
5. Ensure the output cables are appropriately terminated at the combiner box and not connected to any other circuits.
6. Connect the appropriate cables to the output (OUT) of the String Optimizer. Pay special attention to the voltage polarity and the connector gender of these cables as illustrated in Figure 9. See:
 - *Electrical Connections* on page 16.
 - *Cabling Connectors* on page 18.

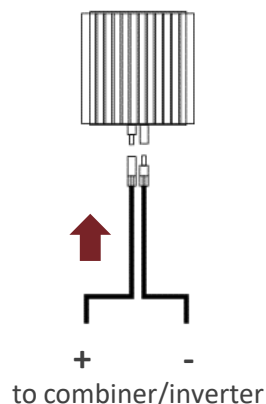

Figure 9: Connecting the output connectors

7. Ensure the planned input connections meet the acceptable criteria.
 - See *Inputs* on page 15.
8. Connect the modules in series for each input by following your procedures and safety protocols.
9. Validate the voltage *and polarity* of the modules in series as well as the connector gender before connecting them to inputs 1 and 2 by following your procedures and safety protocols.

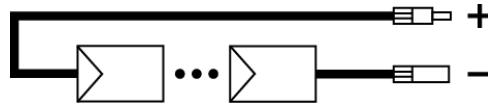

Figure 10: Polarity and gender for each input connector

10. Connect the series of modules for Input 2 to the String Optimizer.

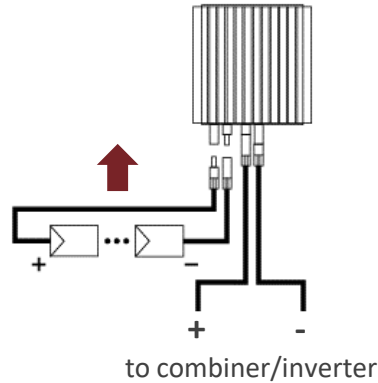

Figure 11: Connecting Input 2

11. Connect the series of modules for Input 1 to the String Optimizer.

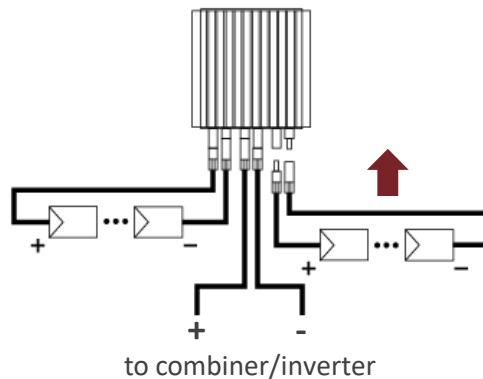

Figure 12: Connecting Input 1

12. Ensure that the locking mechanisms on all connectors are fully engaged.

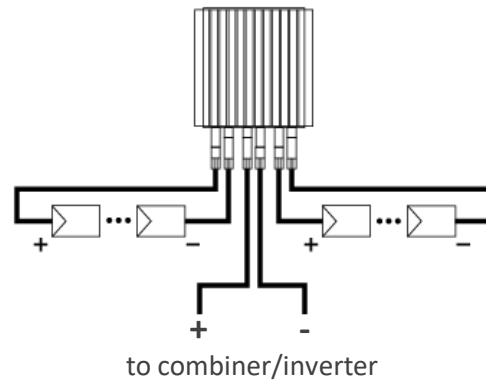

Figure 13: Verify that the connectors are fully engaged

13. Proceed to the next section and verify electrical connections.

Verifying Electrical Connections

WARNING

Read the warning statements below:

Installation and maintenance should be performed only by qualified persons. Installers and maintenance personnel assume the risk of all injury that might occur during installation or maintenance including, without limitation, the risk of electric shock. Follow your safety procedures and protocols.

Do not make or break connections under load.

NOTICE

Because Ampt String Optimizers alter the I-V curve of the array, curve tracers are not recommended during commissioning.

Before Connecting the Optimizer Output in parallel to other circuits:

1. Read the warning and notice statements above.
2. Verify the optimizer circuit is isolated and not under load by following your safety procedures and protocols.
3. Verify the output voltage *and polarity* of the String Optimizer by measuring the optimizer output string voltage at the combiner box by following your safety procedures and protocols.
 - a. The measured output voltage should be the maximum of either:
 - i. The optimizer's maximum output voltage.
 - ii. The greater of the two input voltages.
4. Verify that there is zero current flowing through the optimizer circuit by using a current clamp on each wire connected to the optimizer. Individually test each wire connected to Input 1, Input 2, and the output.
 - a. If current is detected on any of these cables, STOP and go immediately to the *Unexpected Current Detected* section on page 27.

Verify Operational Currents and/or Output Power

1. Read the warning and notice statements above.
2. Because the String Optimizers effectively change strings from current sources to power sources, they deliver full power at a variety of voltages and currents. Therefore, both the output voltage and current must be known to validate output performance under load. There are two ways to validate performance:
 - a. If all optimizer output string voltages are the same, then the optimizer output string currents will be proportional to the sum of the optimizer input powers at the time of the measurement.

- b. If the optimizer output string voltages are different at the time of measurement, then the optimizer *output voltage x output current = output power* may be used to compare to the sum of the measured or predicted optimizer input powers.

Using the Ampt CU with String Optimizers simplifies operational verification through wireless communication. See ampt.com for more information.

Uninstalling an Optimizer

WARNING

Read the warning statements below:

Installation and maintenance should be performed only by qualified persons. Installers and maintenance personnel assume the risk of all injury that might occur during installation or maintenance including, without limitation, the risk of electric shock. Follow your safety procedures and protocols.

Do not perform any servicing other than that specified in these instructions.

Do not make or break connections under load.

Voltage may be present on the output terminals when an input terminal is connected.

CAUTION

Read that caution statements below:

The Ampt product contains no user-serviceable parts. All repairs and maintenance should be handled in accordance with the instructions and terms contained in the product warranty.

The surface of the heat sink may be hot.

Steps

1. Read the warning and caution statements above.
2. Ensure the String Optimizer is not under load by following your safety procedures and protocols.
3. Verify that there is zero current flowing through the optimizer circuit by using a current clamp on each wire connected to the optimizer. Individually test each wire connected to Input 1, Input 2, and the output.
 - a. If current is detected on any of these cables, STOP and go immediately to the *Unexpected Current Detected* section on page 27.

4. If no current is detected, then use the Amphenol H4 connector unlocking tool to disconnect connectors in the following order:
 - a. Input 1
 - b. Input 2
 - c. Output (OUT)

Unexpected Current Detected

WARNING

Read the warning statements below:

Installation and maintenance should be performed only by qualified persons. Installers and maintenance personnel assume the risk of all injury that might occur during installation or maintenance including, without limitation, the risk of electric shock. Follow your safety procedures and protocols.

Do not make or break connections under load.

Do not perform any servicing other than that specified in these instructions

Voltage may be present on the output terminals when an input terminal is connected.

CAUTION

Read that caution statements below:

The Ampt product contains no user-serviceable parts. All repairs and maintenance should be handled in accordance with the instructions and terms contained in the product warranty.

The surface of the heat sink may be hot.

What this means

If current is detected on either one of the inputs or the output when the String Optimizer is not under load, then this usually indicates that the optimizer has been connected improperly.

Steps

1. Read the warning and caution statements above.
2. Wait for zero irradiance.

3. Before disconnecting, verify that there is zero current flowing through the optimizer circuit by using a current clamp on each wire connected to the optimizer. Individually test each wire connected to Input 1, Input 2, and the output.
4. If no current is detected, then use the Amphenol H4 connector unlocking tool to disconnect connectors in the following order:
 - a. Input 1
 - b. Input 2
 - c. Output (OUT)
5. Follow your safety procedures and protocols to verify that the gender of the connectors, the voltage polarities, and the cable routings match the *Cabling Connectors* section on page 18.
6. Follow the *Making Electrical Connections* procedure starting on page 21.

Appendix

Compliance

The box is not meant to be user serviced or opened in any way.





Model Numbering System

The model numbers for Ampt String Optimizers are in the following format:

- 31570020-xxxx (20A models, ranging from 400 – 1500V)
- 31570021-xxxx (16A models, ranging from 400 – 1500V)
- 31570022-xxxx (12A models, ranging from 400 – 1500V)

...where xxxx equals voltage of the unit (e.g. -0750 is a V750; -1300 is V1300).

Markings

 www.ampt.com 	MAXIMUM VOLTAGE PER INPUT*	 CONFORMS TO UL STD 1741. CERTIFIED TO CSA STD C22.2 NO. 107.1.  Intended PV configuration: ungrounded. Patents: See www.ampt.com/patents
	OPERATING VOLTAGE RANGE PER INPUT	
	MAXIMUM CURRENT PER INPUT (Imp @ STC)	
	MAX PV SHORT-CIRCUIT CURRENT PER INPUT	
	OUTPUT VOLTAGE RANGE	
	MAXIMUM OUTPUT CURRENT	
	MAXIMUM CONTINUOUS OUTPUT POWER	
	AMBIENT TEMPERATURE OPERATING RANGE	
	ENCLOSURE TYPE	
	* SEE INSTRUCTIONS TO CALCULATE MAXIMUM SYSTEM VOLTAGE	

	12A model	16A model	20A models	
	V1500-12	V1500-16	V1350-20	V1500-20
Ampt model number	31570022-1500	31570021-1500	31570020-1350	31570020-1500
Maximum voltage per input (Vdc)	1500	1500	1500	1500
Operating voltage range per input (Vdc)	400 – 1300	400 – 1300	400 – 1300	400 – 1300
Maximum current per input (Imp@STC) (A _{dc})	12.3	12.3	12.8	12.8
Max PV short-circuit current per input (A _{dc})	13.3	13.3	13.3	13.3
Output voltage range (Vdc)	0 – 1500	0 – 1500	0 – 1350	0 – 1500
Maximum output current (A _{dc})	12	16	20	20
Maximum continuous output power (kW _{dc})	16.8	22.4	25.2	28
Ambient temperature operating range	-40°C - 75°C	-40°C - 75°C	-40°C - 75°C	-40°C - 75°C
Enclosure type	IP 66/4X	IP 66/4X	IP 66/4X	IP 66/4X

FCC Compliance

This device complies with part 15 of the FCC Rules. Operation is subject to the following two conditions: (1) This device may not cause harmful interference, and (2) this device must accept any interference received, including interference that may cause undesired operation.

IMPORTANT! Changes or modifications not expressly approved by Ampt, LLC could void the user's authority to operate the equipment.

Model: 1500V
FCC ID # X3R-1500V
IC: 8399A-1500V

RSS-GEN

This device contains license-exempt transmitter(s)/receiver(s) that comply with Innovation, Science and Economic Development Canada's license-exempt RSS(s). Operation is subject to the following two conditions:

1. This device may not cause interference.
2. This device must accept any interference, including interference that may cause undesired operation of the device.

Avis IC

Cet appareil est conforme à la partie 15 des règles de la FCC. Son fonctionnement est soumis aux deux conditions suivantes: (1) Ce dispositif ne peut causer des interférences nuisibles, et (2) cet appareil doit accepter toute interférence reçue, y compris les interférences qui peuvent provoquer un fonctionnement indésirable.

IMPORTANT! Les changements ou modifications non expressément approuvés par Ampt, LLC pourraient annuler l'autorité de l'utilisateur à utiliser l'équipement.

Model: 1500V
FCC ID # X3R-1500V
IC: 8399A-1500V

RSS-GEN

L'émetteur/récepteur exempt de licence contenu dans le présent appareil est conforme aux CNR d'Innovation, Sciences et Développement économique Canada applicables aux appareils radio exempts de licence. L'exploitation est autorisée aux deux conditions suivantes:

1. L'appareil ne doit pas produire de brouillage.
2. L'appareil doit accepter tout brouillage radioélectrique subi, même si le brouillage est susceptible d'en compromettre le fonctionnement.

Contacts

Headquarters

Ampt, LLC
4850 Innovation Drive
Fort Collins, CO 80525
970-372-6950

Sales

Global: sales@ampt.com

North America: p: +1 970.372.6952
f: +1 970.225.0483

Europe: p: +49 7456 20 88 42
f: +49 7456 20 88 43

Japan: p: +81.45.565.9977
f: +81.45.565.9938

Support

Global: support@ampt.com

North America: p: +1 970.372.6951
f: +1 970.225.0483

Europe: p: +49 7456 20 88 42
f: +49 7456 20 88 43

Japan: p: +81.45.565.9977
f: +81.45.565.9938

