

## TEST REPORT

**Report No.: 22030544HKG-001**

Design Pool Limited

Application For Certification  
(Original Grant)

**FCC ID: X3QDROMS01**

Wireless Power Transfer Device - Transmitter

**Prepared and Checked by:**

**Approved by:**

Signed on File

Leung Chun Ning, Peter  
Assistant Engineer

---

Wong Kwok Yeung, Kenneth

Assistant Supervisor

Date: June 17, 2022

## TEST REPORT

### GENERAL INFORMATION

<b>Grantee:</b>	Design Pool Limited
<b>Grantee Address:</b>	33/F., 88 Hing Fat Street, Causeway Bay, Hong Kong.
<b>Contact Person:</b>	Igor Duc
<b>Tel:</b>	+852 2522 0880
<b>Fax:</b>	+852 2522 0803
<b>E-mail:</b>	igorduc@nativeunion.com
<b>Manufacturer:</b>	PYS High-Tech Co., Ltd.
<b>Manufacturer Address:</b>	Block 9, Lianhua Industrial Park, Longyuan Road, Longhua, Shenzhen, China
<b>Brand Name:</b>	Native Union
<b>Model:</b>	DROMS01
<b>Type of EUT:</b>	Transceiver
<b>Description of EUT:</b>	DROP MAGNETIC WIRELESS CHARGER
<b>Serial Number:</b>	N/A
<b>FCC ID:</b>	X3QDROMS01
<b>Date of Sample Submitted:</b>	March 10, 2022
<b>Date of Test:</b>	March 10, 2022 to April 29, 2022
<b>Report No.:</b>	22030544HKG-001
<b>Report Date:</b>	June 17, 2022
<b>Environmental Conditions:</b>	Temperature: +10 to 40°C Humidity: 10 to 90%
<b>Conclusion:</b>	Test was conducted by client submitted sample. The submitted sample as received complied with the 47 CFR Part 15 Certification.

## TEST REPORT

### SUMMARY OF TEST RESULT

Test Specification	Reference	Results
Transmitter Power Line Conducted Emissions	15.207	Complied
Radiated Emission Radiated Emission on the Bandedge	15.249, 15.209	Complied
Radiated Emission in Restricted Bands	15.205	Complied

The equipment under test is found to be complying with the following standards:  
FCC Part 15, October 1, 2020 Edition

- Note:
1. The EUT uses a permanently attached antenna which, in accordance to section 15.203, is considered sufficient to comply with the pervisions of this section.
  2. Pursuant to FCC part 15 Section 15.215(c), the 20 dB bandwidth of the emission was contained within the frequency band designated (mentioned as above) which the EUT operated. The effects, if any, from frequency sweeping, frequency hopping, other modulation techniques and frequency stability over excepted variations in temperature and supply voltage were considered.

**TEST REPORT**

**TABLE OF CONTENTS**

**1.0 GENERAL DESCRIPTION..... 5**

1.1 Product Description .....5

1.2 Related Submittal(s) Grants.....5

1.3 Test Methodology .....5

1.4 Test Facility.....5

**2.0 SYSTEM TEST CONFIGURATION..... 6**

2.1 Justification .....6

2.2 EUT Exercising Software.....6

2.3 Special Accessories.....6

2.4 Measurement Uncertainty.....6

2.5 Support Equipment List and Description .....7

**3.0 EMISSION RESULTS..... 8**

3.1 Field Strength Calculation .....8

3.2 Radiated Emission Configuration Photograph.....9

3.3 Radiated Emission Data .....9

3.4 Conducted Emission Configuration Photograph .....9

3.5 Conducted Emission Data .....9

**4.0 EQUIPMENT PHOTOGRAPHS..... 21**

**5.0 PRODUCT LABELLING..... 21**

**6.0 TECHNICAL SPECIFICATIONS ..... 21**

**7.0 INSTRUCTION MANUAL ..... 21**

**8.0 MISCELLANEOUS INFORMATION ..... 22**

8.1 Measured Bandwidth.....22

8.2 Emissions Test Procedures.....22

8.3 Occupied Bandwidth.....25

**9.0 CONFIDENTIALITY REQUEST..... 26**

**10.0 EQUIPMENT LIST ..... 26**

## TEST REPORT

### 1.0 GENERAL DESCRIPTION

#### 1.1 Product Description

The Equipment Under Test (EUT), is a wireless charger that is designed to work on table. The EUT is powered by USB- Type C adaptor, which is operated at 127.6kHz for Maximum 15W wireless power transmission.

Antenna Type: Internal, Integral

For electronic filing, the brief circuit description is saved with filename: descri.pdf.

#### 1.2 Related Submittal(s) Grants

This is a single application for certification of a transceiver.

#### 1.3 Test Methodology

Both AC mains line-conducted and radiated emission measurements were performed according to the procedures in ANSI C63.10 (2013). All radiated measurements were performed in an 3m Chamber. Preliminary scans were performed in the 3m Chamber only to determine worst case modes. All radiated tests were performed at an antenna to EUT distance of 3 meters, unless stated otherwise in the “**Justification Section**” of this Application.

#### 1.4 Test Facility

The 3m Chamber and conducted measurement facility used to collect the radiated data is located at Workshop No. 3, G/F., World-Wide Industrial Centre, 43-47 Shan Mei Street, Fo Tan, Sha Tin, N.T., Hong Kong SAR, China. This test facility and site measurement data have been placed on file with the FCC.

## TEST REPORT

### 2.0 SYSTEM TEST CONFIGURATION

#### 2.1 Justification

The system was configured for testing in a typical fashion (as a customer would normally use it), and in the confines as outlined in ANSI C63.10 (2013).

The device was powered by AC/DC Adaptor with USB-C Port of 5-12VDC (Input: 100-240VAC 50-60Hz; Output: 5.0 – 12.0VDC 1.5A -3A).

For maximizing emissions below 30 MHz, the EUT was rotated through 360°, the centre of the loop antenna was placed 1 meter above the ground, and the antenna polarization was changed. For maximizing emission at and above 30 MHz, the EUT was rotated through 360°, the antenna height was varied from 1 meter to 4 meters above the ground plane, and the antenna polarization was changed. This step by step procedure for maximizing emissions led to the data report in Exhibit 3.0.

The rear of unit shall be flushed with the rear of the table.

The equipment under test (EUT) was configured for testing in a typical fashion (as a customer would normally use it). The EUT was mounted to a plastic stand if necessary and placed on the wooden turntable, which enabled the engineer to maximize emissions through its placement in the three orthogonal axes.

#### 2.2 EUT Exercising Software

There was no special software to exercise the device. Once the unit is powered up, it transmits the RF Signal continuously.

#### 2.3 Special Accessories

There are no special accessories necessary for compliance of this product.

#### 2.4 Measurement Uncertainty

Decision Rule for compliance: For FCC/IC standard, the measured value must be within the limits of applicable standard without accounting for the measurement uncertainty. For EN/IEC/HKTA/HKTC standard, conformity rules will be used as per standard directly excepted EN/IEC 61000-3-2, EN/IEC 61000-3-3, HKTA1004, HKCA1008, HKTA1019, HKTA1020, HKTA1041 and HKTA1044. For these excepted or not mentioned standards, Cl 4.2.2 of ILAC-G8:09/2019 decision rules will be reference and guard band will be equal to our measurement uncertainty with 95% confidence level ( $k=2$ ). In case, the measured value is within guard band region, undetermined decision will be used.

Uncertainty and Compliance - Unless the standard specifically states that measured values are to be extended by the measurement uncertainty in determining compliance, all compliance determinations are based on the actual measured value.

## TEST REPORT

### 2.5 Support Equipment List and Description

Description	Remark
15W Loading	Provided by Intertek
AC/DC adaptor with USB-C Port of 5-12VDC Model: SMPD02 Input: 100-240VAC 50-60Hz Output: 5.0-12.0VDC 1.5A-3.0A	Provided by Applicant
1 x USB cable with length of 2.02 meter long	Provided by Applicant

## TEST REPORT

### 3.0 EMISSION RESULTS

Data is included of the worst case configuration (the configuration which resulted in the highest emission levels). A sample calculation, configuration photographs and data tables of the emissions are included.

#### 3.1 Field Strength Calculation

The field strength is calculated by adding the Antenna Factor and Cable Factor, and subtracting the Amplifier Gain (if any), Average Factor (optional) from the measured reading.

The basic equation with a sample calculation is as follows:

$$FS = RA + AF + CF - AG - AV$$

where

- FS = Field Strength in dB $\mu$ V/m
- RA = Receiver Amplitude (including preamplifier) in dB $\mu$ V
- AF = Antenna Factor in dB
- CF = Cable Attenuation Factor in dB
- AG = Amplifier Gain in dB
- AV = Average Factor in dB

In the following table(s), the reading shown on the data table reflects the preamplifier gain.

An example for the calculations in the following table is as follows:

$$FS = RR + LF$$

where

- FS = Field Strength in dB $\mu$ V/m
- RR = RA - AG - AV in dB $\mu$ V
- LF = CF + AF in dB

Assume a receiver reading of 52.0 dB $\mu$ V is obtained. The antenna factor of 7.4 dB and cable factor of 1.6 dB are added. The amplifier gain of 29.0 dB and average factor of 5.0 dB are subtracted, giving a field strength of 27.0 dB $\mu$ V/m. This value in dB $\mu$ V/m was converted to its corresponding level in  $\mu$ V/m.

RA = 52.0 dB $\mu$ V/m	
AF = 7.4 dB	RR = 18.0 dB $\mu$ V
CF = 1.6 dB	LF = 9.0 dB
AG = 29.0 dB	
AV = 5.0 dB	
FS = RR + LF	
FS = 18 + 9 = 27 dB $\mu$ V/m	

Level in  $\mu$ V/m = Common Antilogarithm [(27 dB $\mu$ V/m)/20] = 22.4  $\mu$ V/m



## TEST REPORT

### 3.2 Radiated Emission Configuration Photograph

The worst case in radiated emission was found at 46.853 MHz

For electronic filing, the worst case radiated emission configuration photographs are saved with filename: radiated photos.pdf.

### 3.3 Radiated Emission Data

The data on the following page lists the significant emission frequencies, the limit and the margin of compliance. Numbers with a minus sign are below the limit.

Judgment: Passed by 5.32 dB

### 3.4 Conducted Emission Configuration Photograph

The worst case in line-conducted emission was found at 2.9355 MHz

For electronic filing, the worst case line-conducted configuration photographs are saved with filename: conducted photo.pdf.

### 3.5 Conducted Emission Data

For electronic filing, the graph and data table of conducted emission is saved with filename: conducted.pdf.

Judgment: Pass by 3.87 dB

**TEST REPORT**

**CONDUCTED EMISSION**

Model: DROMS01  
Date of Test: April 29, 2022  
Worst-Case Operating Mode: Load in 2mm Distance

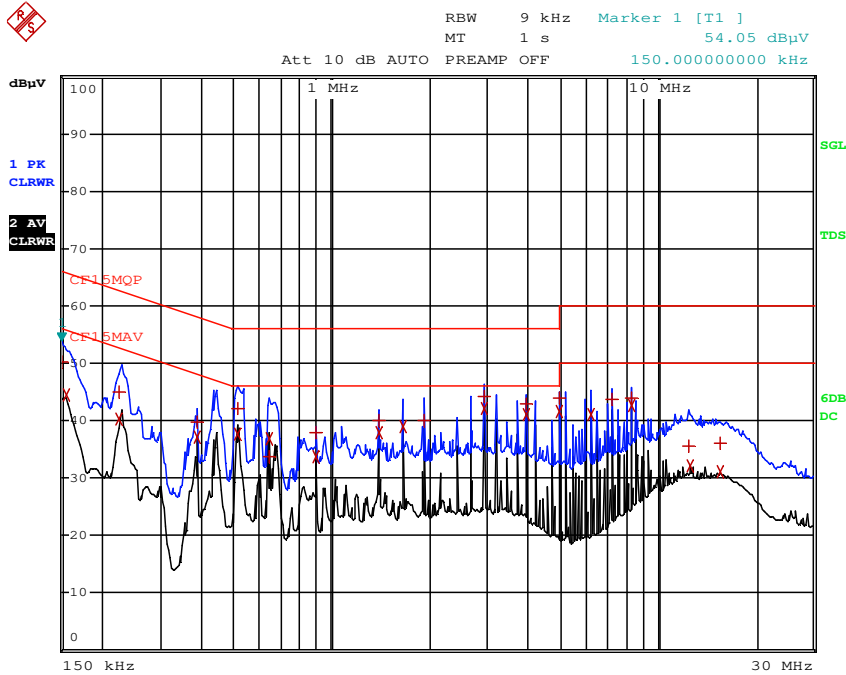

Note: Measurement Uncertainty is  $\pm 4.2$ dB at a level of confidence of 95%.

**TEST REPORT**

**CONDUCTED EMISSION (CONT'D)**

Model: DROMS01  
Date of Test: April 29, 2022  
Worst-Case Operating Mode: Load in 2mm Distance

EDIT PEAK LIST (Final Measurement Results)				
Trace1: CF15MQP				
Trace2: CF15MAV				
Trace3: ---				
TRACE	FREQUENCY	LEVEL dBµV		DELTA LIMIT dB
1	Quasi Peak 150 kHz	50.25	L1	-15.74
2	CISPR Average 154.5 kHz	44.59	L1	-11.15
1	Quasi Peak 226.5 kHz	45.06	L1	-17.51
2	CISPR Average 226.5 kHz	40.28	L1	-12.28
1	Quasi Peak 384 kHz	39.75	N	-18.43
2	CISPR Average 384 kHz	37.08	N	-11.10
1	Quasi Peak 514.5 kHz	42.24	L1	-13.75
2	CISPR Average 514.5 kHz	37.55	L1	-8.44
2	CISPR Average 640.5 kHz	36.97	L1	-9.02
1	Quasi Peak 645 kHz	33.65	L1	-22.34
1	Quasi Peak 892.5 kHz	37.94	N	-18.05
2	CISPR Average 892.5 kHz	33.64	N	-12.35
1	Quasi Peak 1.4055 MHz	40.14	L1	-15.85
2	CISPR Average 1.4055 MHz	38.05	L1	-7.94
2	CISPR Average 1.662 MHz	38.98	L1	-7.01
1	Quasi Peak 1.914 MHz	40.01	L1	-15.98
1	Quasi Peak 2.9355 MHz	44.10	L1	-11.89
2	CISPR Average 2.9355 MHz	42.12	L1	-3.87
1	Quasi Peak 3.957 MHz	42.91	N	-13.09
2	CISPR Average 3.957 MHz	40.98	N	-5.01

EDIT PEAK LIST (Final Measurement Results)				
Trace1: CF15MQP				
Trace2: CF15MAV				
Trace3: ---				
TRACE	FREQUENCY	LEVEL dBµV		DELTA LIMIT dB
1	Quasi Peak 4.9785 MHz	43.85	N	-12.14
2	CISPR Average 4.9785 MHz	41.66	N	-4.33
2	CISPR Average 6.2565 MHz	41.15	N	-8.84
1	Quasi Peak 7.278 MHz	43.72	N	-16.27
1	Quasi Peak 8.2995 MHz	43.90	N	-16.09
2	CISPR Average 8.2995 MHz	42.53	L1	-7.46
1	Quasi Peak 12.462 MHz	35.63	L1	-24.36
2	CISPR Average 12.6375 MHz	32.14	L1	-17.86
1	Quasi Peak 15.576 MHz	36.17	L1	-23.82
2	CISPR Average 15.576 MHz	31.01	L1	-18.98

Note: Measurement Uncertainty is ±4.2dB at a level of confidence of 95%.

**TEST REPORT**

**CONDUCTED EMISSION**

Model: DROMS01  
Date of Test: April 29, 2022  
Worst-Case Operating Mode: 15W Loading

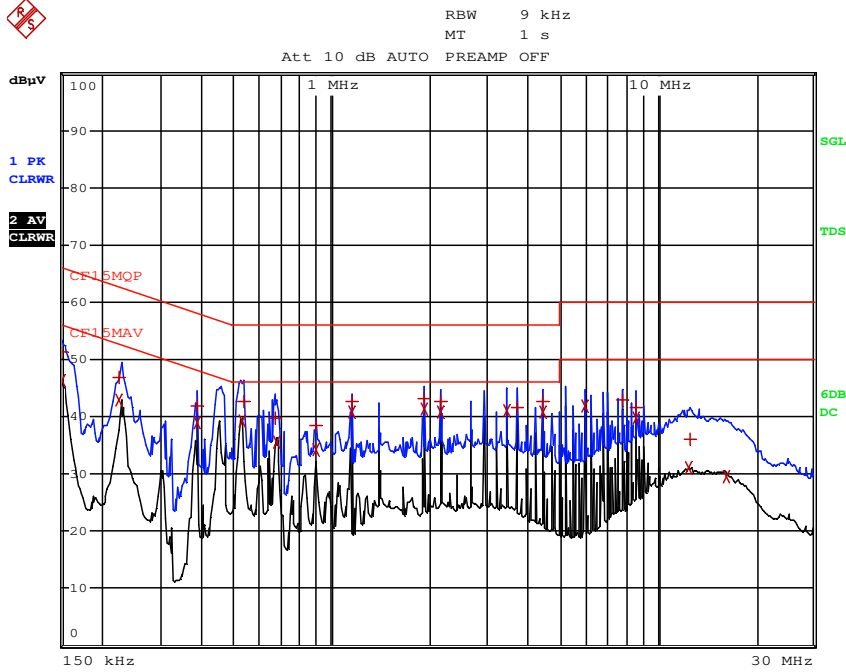

Note: Measurement Uncertainty is  $\pm 4.2$ dB at a level of confidence of 95%.

**TEST REPORT**

**CONDUCTED EMISSION (CONT'D)**

Model: DROMS01  
Date of Test: April 29, 2022  
Worst-Case Operating Mode: 15W Loading

EDIT PEAK LIST (Final Measurement Results)				
Trace1:	CF15MQP			
Trace2:	CF15MAV			
Trace3:	---			
TRACE	FREQUENCY	LEVEL dBµV		DELTA LIMIT dB
1 Quasi Peak	150 kHz	51.22	N	-14.77
2 CISPR Average	150 kHz	46.28	L1	-9.71
1 Quasi Peak	226.5 kHz	46.74	L1	-15.83
2 CISPR Average	226.5 kHz	42.92	L1	-9.65
1 Quasi Peak	384 kHz	41.81	N	-16.38
2 CISPR Average	384 kHz	38.95	N	-9.23
2 CISPR Average	528 kHz	39.18	L1	-6.81
1 Quasi Peak	537 kHz	42.75	L1	-13.24
1 Quasi Peak	672 kHz	39.72	L1	-16.27
2 CISPR Average	676.5 kHz	35.60	L1	-10.39
1 Quasi Peak	892.5 kHz	38.32	N	-17.67
2 CISPR Average	892.5 kHz	34.14	N	-11.85
1 Quasi Peak	1.149 MHz	42.61	L1	-13.39
2 CISPR Average	1.149 MHz	40.89	L1	-5.10
1 Quasi Peak	1.914 MHz	43.29	L1	-12.70
2 CISPR Average	1.914 MHz	41.35	L1	-4.65
1 Quasi Peak	2.1705 MHz	42.68	L1	-13.31
2 CISPR Average	2.1705 MHz	40.70	L1	-5.29
2 CISPR Average	3.4485 MHz	41.12	L1	-4.87
1 Quasi Peak	3.705 MHz	41.57	L1	-14.43

EDIT PEAK LIST (Final Measurement Results)				
Trace1:	CF15MQP			
Trace2:	CF15MAV			
Trace3:	---			
TRACE	FREQUENCY	LEVEL dBµV		DELTA LIMIT dB
1 Quasi Peak	4.47 MHz	42.77	N	-13.22
2 CISPR Average	4.47 MHz	40.82	N	-5.17
2 CISPR Average	6 MHz	41.90	N	-8.09
1 Quasi Peak	7.7865 MHz	42.80	N	-17.19
1 Quasi Peak	8.556 MHz	41.54	L1	-18.45
2 CISPR Average	8.556 MHz	39.80	L1	-10.19
2 CISPR Average	12.3855 MHz	31.05	L1	-18.94
1 Quasi Peak	12.5115 MHz	36.02	L1	-23.97
2 CISPR Average	16.1655 MHz	29.41	L1	-20.58

Note: Measurement Uncertainty is ±4.2dB at a level of confidence of 95%.

**TEST REPORT**

**CONDUCTED EMISSION**

Model: DROMS01  
Date of Test: April 29, 2022  
Worst-Case Operating Mode: Standby

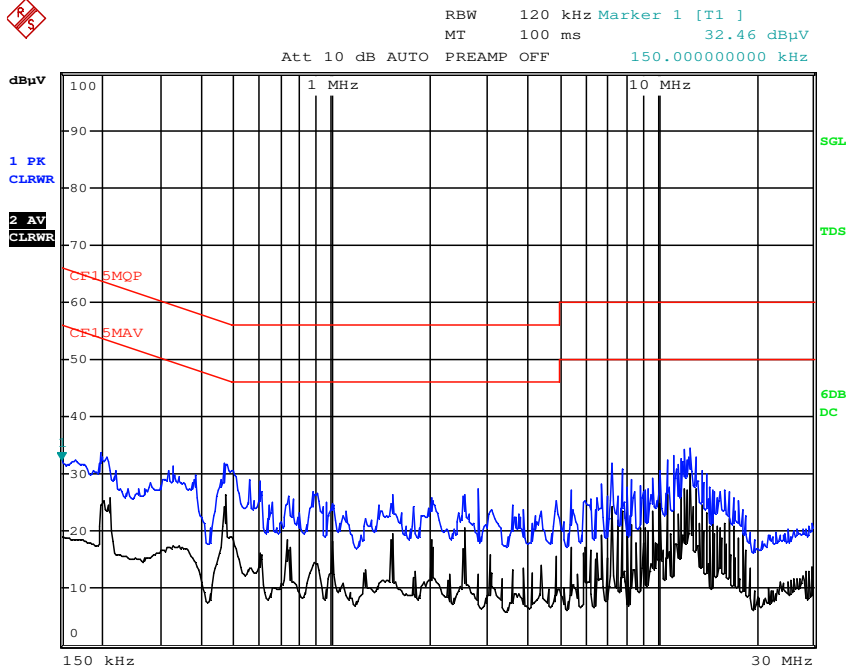

Note: Measurement Uncertainty is  $\pm 4.2$ dB at a level of confidence of 95%.

**TEST REPORT**

**RADIATED EMISSIONS**

Model: DROMS01  
Date of Test: April 29, 2022  
Worst-Case Operating Mode: Charging with Load

Table 1  
Pursuant to FCC Part 15 Section 15.209 Requirement

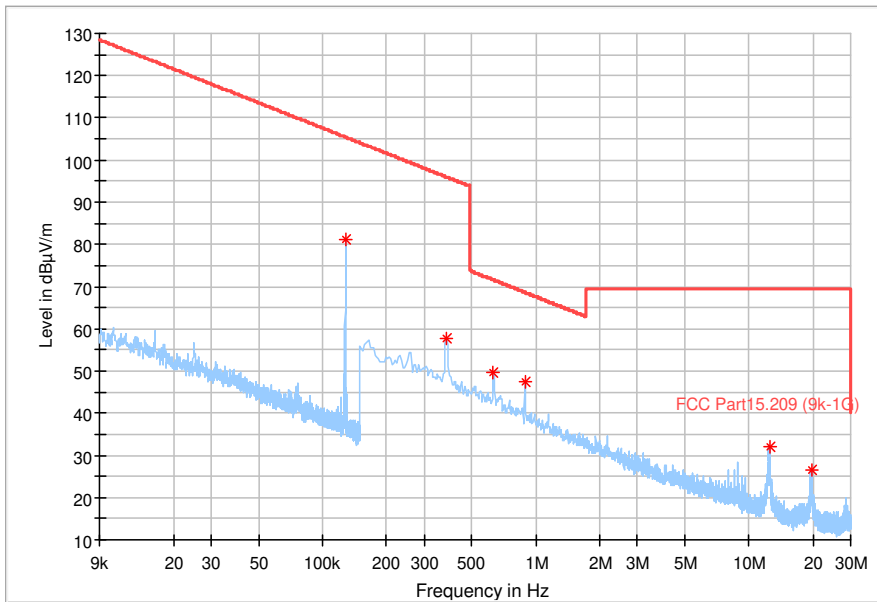

Frequency (MHz)	Read Level (dBµV)	MaxPeak (dBµV/m)	Limit (dBµV/m)	Margin (dB)	Height (cm)	Pol	Azimuth (deg)	Corr. (dB/m)
0.127669	69.57	81.07	105.48	-24.41	100.0	O	295.0	11.5
0.381338	45.99	57.59	95.98	-38.39	100.0	O	312.0	11.6
0.635063	38.18	49.68	71.55	-21.87	100.0	O	64.0	11.5
0.892519	36.18	47.58	68.59	-21.02	100.0	O	294.0	11.4
12.507900	21.26	31.96	69.54	-37.58	100.0	O	40.0	10.7
19.638319	15.79	26.39	69.54	-43.15	100.0	O	0.0	10.6

- NOTES: 1. Peak Detector Data unless otherwise stated.  
 2. All measurements were made at 3 meters.  
 3. Negative value in the margin column shows emission below limit.  
 4. Loop antenna is used for the emissions below 30MHz.  
 5. Emissions within the restricted band meets the requirement of FCC Part 15 Section 15.205.  
 6. Measurement Uncertainty is ±5.3dB at a level of confidence of 95%.  
 7. Corr. (dB/m) = Antenna Factor (dB) + Cable Loss (dB)  
 Max Peak (dBµV/m) = Corr. (dB/m) + Read Level (dBµV)  
 Margin (dB) = Max Peak (dBµV/m) – Limit (dBµV/m)

**TEST REPORT**

**RADIATED EMISSIONS**

Model: DROMS01  
Date of Test: April 29, 2022  
Worst-Case Operating Mode: Charging with Load in 2mm Distance

Table 2  
Pursuant to FCC Part 15 Section 15.209 Requirement

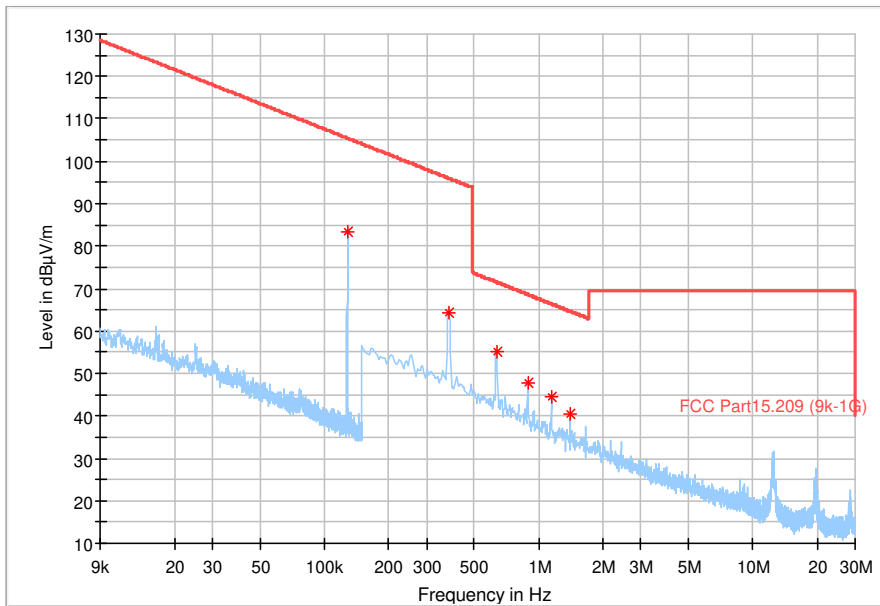

Frequency (MHz)	Read Level (dBµV)	MaxPeak (dBµV/m)	Limit (dBµV/m)	Margin (dB)	Height (cm)	Pol	Azimuth (deg)	Corr. (dB/m)
0.127652	72.00	83.50	105.48	-21.99	100.0	O	320.0	11.5
0.381338	52.58	64.18	95.98	-31.80	100.0	O	329.0	11.6
0.638794	43.74	55.24	71.49	-16.26	100.0	O	333.0	11.5
0.892519	36.46	47.86	68.59	-20.74	100.0	O	326.0	11.4
1.149975	33.16	44.66	66.39	-21.73	100.0	O	289.0	11.5
1.403700	28.90	40.50	64.66	-24.16	100.0	O	322.0	11.6

- NOTES: 1. Peak Detector Data unless otherwise stated.  
2. All measurements were made at 3 meters.  
3. Negative value in the margin column shows emission below limit.  
4. Loop antenna is used for the emissions below 30MHz.  
5. Emissions within the restricted band meets the requirement of FCC Part 15 Section 15.205.  
6. Measurement Uncertainty is ±5.3dB at a level of confidence of 95%.  
7. Corr. (dB/m) = Antenna Factor (dB) + Cable Loss (dB)  
Max Peak (dBµV/m) = Corr. (dB/m) + Read Level (dBµV)  
Margin (dB) = Max Peak (dBµV/m) – Limit (dBµV/m)



**TEST REPORT**

**RADIATED EMISSIONS**

Model: DROMS01  
Date of Test: April 29, 2022  
Worst-Case Operating Mode: Standby

Table 3  
Pursuant to FCC Part 15 Section 15.209 Requirement

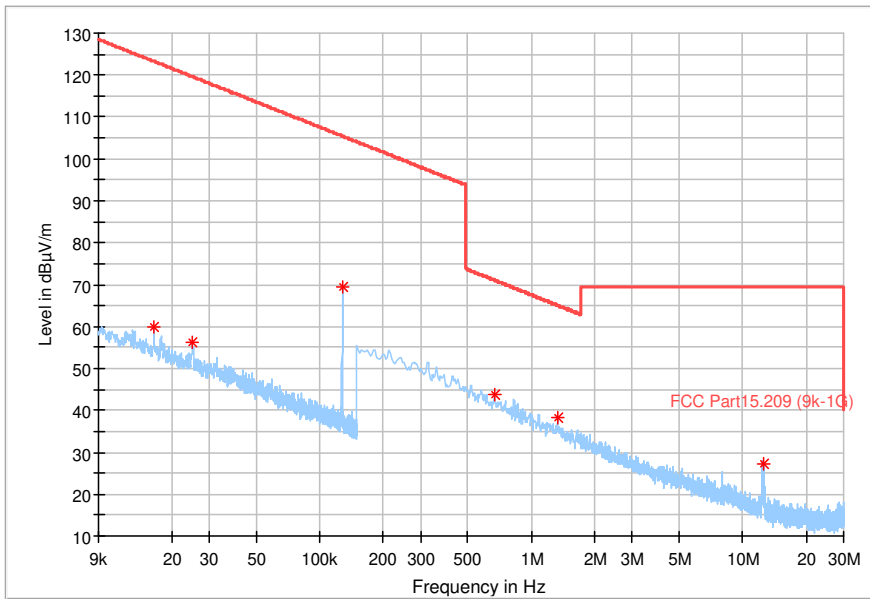

Frequency (MHz)	Read Level (dBµV)	MaxPeak (dBµV/m)	Limit (dBµV/m)	Margin (dB)	Height (cm)	Pol	Azimuth (deg)	Corr. (dB/m)
0.016420	43.94	60.04	123.30	-63.26	100.0	O	69.0	16.1
0.024968	42.04	56.14	119.66	-63.52	100.0	O	330.0	14.1
0.127652	58.08	69.58	105.48	-35.91	100.0	O	261.0	11.5
0.668644	32.28	43.88	71.10	-27.23	100.0	O	160.0	11.6
1.332806	26.57	38.17	65.11	-26.94	100.0	O	359.0	11.6
12.530288	16.71	27.41	69.54	-42.13	100.0	O	10.0	10.7

- NOTES:
1. Peak Detector Data unless otherwise stated.
  2. All measurements were made at 3 meters.
  3. Negative value in the margin column shows emission below limit.
  4. Loop antenna is used for the emissions below 30MHz.
  5. Emissions within the restricted band meets the requirement of FCC Part 15 Section 15.205.
  6. Measurement Uncertainty is  $\pm 5.3$ dB at a level of confidence of 95%.
  7.  $Corr. (dB/m) = Antenna\ Factor (dB) + Cable\ Loss (dB)$   
 $Max\ Peak (dB\mu V/m) = Corr. (dB/m) + Read\ Level (dB\mu V)$   
 $Margin (dB) = Max\ Peak (dB\mu V/m) - Limit (dB\mu V/m)$

**TEST REPORT**

**RADIATED EMISSIONS**

Model: DROMS01  
Date of Test: April 29, 2022  
Worst-Case Operating Mode: Charging with Load

Table 4  
Pursuant to FCC Part 15 Section 15.209 Requirement

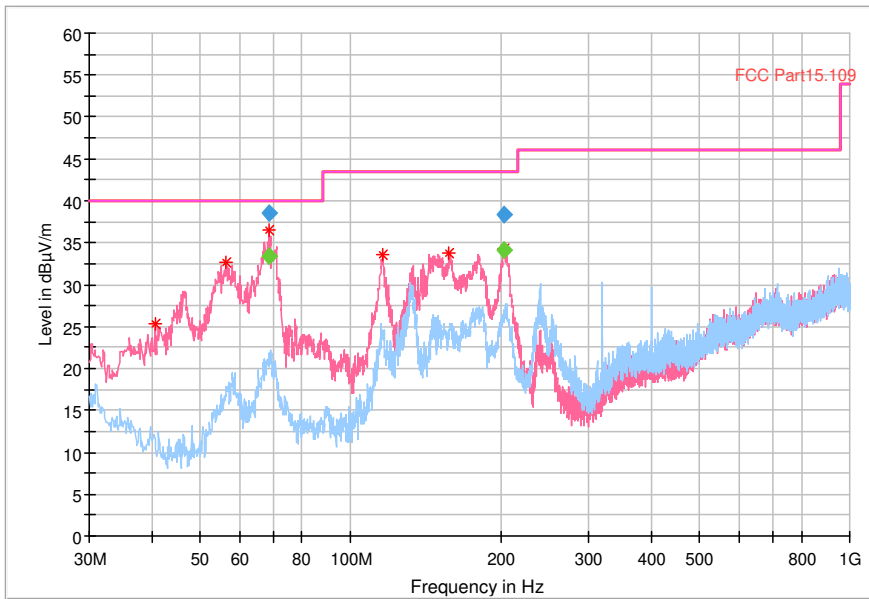

Frequency (MHz)	QuasiPeak (dBµV/m)	Limit (dBµV/m)	Margin (dB)	Height (cm)	Pol	Azimuth (deg)	Corr. (dB/m)
68.800000	33.41	40.00	-6.59	100.0	V	348.0	8.0
202.781250	34.16	43.50	-9.34	100.0	V	336.0	11.9

Frequency (MHz)	MaxPeak (dBµV/m)	Limit (dBµV/m)	Margin (dB)	Height (cm)	Pol	Azimuth (deg)	Corr. (dB/m)
40.548750	25.26	40.00	-14.74	100.0	V	332.0	11.4
56.553750	32.58	40.00	-7.42	100.0	V	85.0	7.9
68.800000	36.47	40.00	-3.53	100.0	V	348.0	8.0
116.087500	33.60	43.50	-9.90	100.0	V	292.0	9.3
157.676250	33.82	43.50	-9.68	100.0	V	16.0	11.3
202.781250	34.24	43.50	-9.26	100.0	V	336.0	11.9

- NOTES: 1. Peak Detector Data unless otherwise stated.  
 2. All measurements were made at 3 meters.  
 3. Negative value in the margin column shows emission below limit.  
 4. Loop antenna is used for the emissions below 30MHz.  
 5. Emissions within the restricted band meets the requirement of FCC Part 15 Section 15.205.  
 6. Measurement Uncertainty is ±5.3dB at a level of confidence of 95%.  
 7. Corr. (dB/m) = Antenna Factor (dB) + Cable Loss (dB)  
 Max Peak (dBµV/m) = Corr. (dB/m) + Read Level (dBµV)  
 Margin (dB) = Max Peak (dBµV/m) – Limit (dBµV/m)

**TEST REPORT**

**RADIATED EMISSIONS**

Model: DROMS01  
Date of Test: April 29, 2022  
Worst-Case Operating Mode: Charging with Load in 2mm Distance

Table 5  
Pursuant to FCC Part 15 Section 15.209 Requirement

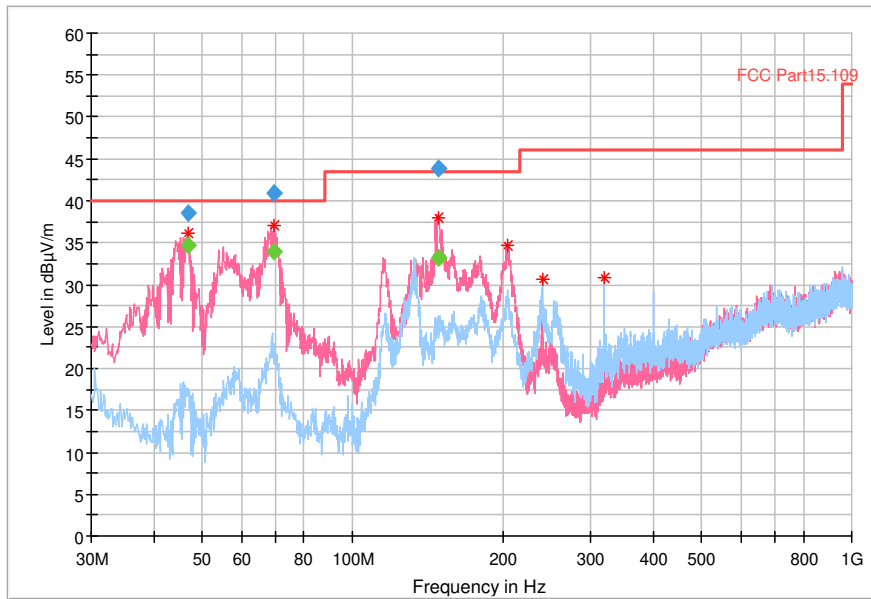

Frequency (MHz)	QuasiPeak (dBµV/m)	Limit (dBµV/m)	Margin (dB)	Height (cm)	Pol	Azimuth (deg)	Corr. (dB/m)
46.853750	34.68	40.00	-5.32	100.0	V	349.0	8.9
69.770000	33.95	40.00	-6.05	100.0	V	0.0	8.2
148.946250	33.21	43.50	-10.29	100.0	V	96.0	10.9

Frequency (MHz)	MaxPeak (dBµV/m)	Limit (dBµV/m)	Margin (dB)	Height (cm)	Pol	Azimuth (deg)	Corr. (dB/m)
204.600000	34.63	43.50	-8.87	100.0	V	358.0	12.0
240.005000	30.63	46.00	-15.37	100.0	H	311.0	13.9
320.030000	30.79	46.00	-15.21	100.0	H	359.0	16.1

- NOTES: 1. Quasi-Peak Detector Data unless otherwise stated.  
 2. All measurements were made at 3 meters.  
 3. Negative value in the margin column shows emission below limit.  
 4. Loop antenna is used for the emissions below 30MHz.  
 5. Emissions within the restricted band meets the requirement of FCC Part 15 Section 15.205.  
 6. Measurement Uncertainty is ±5.3dB at a level of confidence of 95%.  
 7. Corr. (dB/m) = Antenna Factor (dB) + Cable Loss (dB)  
 Max Peak (dBµV/m) = Corr. (dB/m) + Read Level (dBµV)  
 Margin (dB) = Max Peak (dBµV/m) – Limit (dBµV/m)

**TEST REPORT**

**RADIATED EMISSIONS**

Model: DROMS01  
Date of Test: April 29, 2022  
Worst-Case Operating Mode: Standby

Table 6  
Pursuant to FCC Part 15 Section 15.209 Requirement

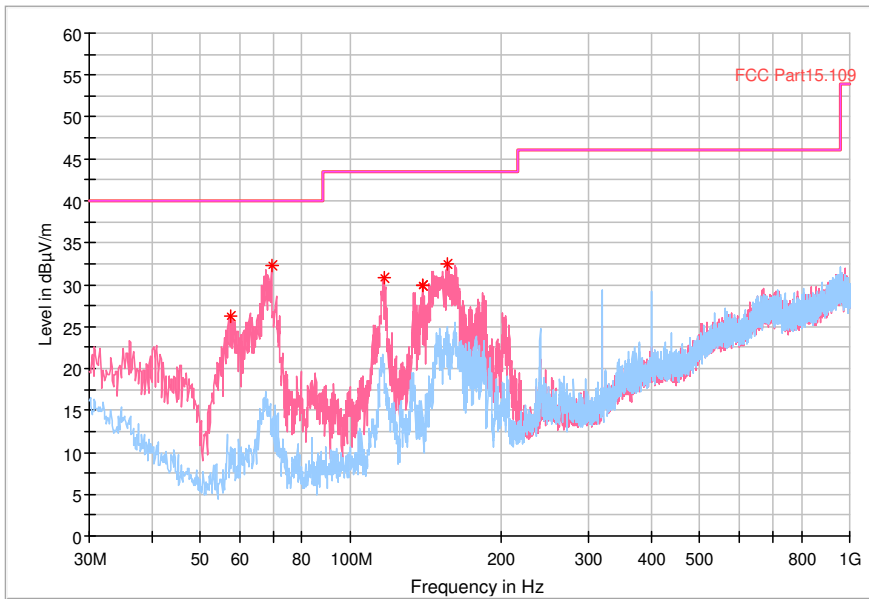

Frequency (MHz)	MaxPeak (dBµV/m)	Limit (dBµV/m)	Margin (dB)	Height (cm)	Pol	Azimuth (deg)	Corr. (dB/m)
57.645000	26.25	40.00	-13.75	100.0	V	140.0	7.9
69.527500	32.21	40.00	-7.79	100.0	V	334.0	8.1
116.936250	30.76	43.50	-12.74	100.0	V	287.0	9.2
139.246250	29.88	43.50	-13.62	100.0	V	67.0	9.5
139.731250	29.88	43.50	-13.62	100.0	V	67.0	9.5
156.342500	32.54	43.50	-10.96	100.0	V	338.0	11.3

- NOTES: 1. Peak Detector Data unless otherwise stated.  
 2. All measurements were made at 3 meters.  
 3. Negative value in the margin column shows emission below limit.  
 4. Loop antenna is used for the emissions below 30MHz.  
 5. Emissions within the restricted band meets the requirement of FCC Part 15 Section 15.205.  
 6. Measurement Uncertainty is ±5.3dB at a level of confidence of 95%.  
 7. Corr. (dB/m) = Antenna Factor (dB) + Cable Loss (dB)  
 Max Peak (dBµV/m) = Corr. (dB/m) + Read Level (dBµV)  
 Margin (dB) = Max Peak (dBµV/m) – Limit (dBµV/m)

## TEST REPORT

### 4.0 EQUIPMENT PHOTOGRAPHS

For electronic filing, the photographs are saved with filename: external photos.pdf and internal photos.pdf.

### 5.0 PRODUCT LABELLING

For electronics filing, the FCC ID label artwork and the label location are saved with filename: label.pdf.

### 6.0 TECHNICAL SPECIFICATIONS

For electronic filing, the block diagram and schematic of the tested EUT are saved with filename: block.pdf and circuit.pdf respectively.

### 7.0 INSTRUCTION MANUAL

For electronic filing, a preliminary copy of the Instruction Manual is saved with filename: manual.pdf.

This manual will be provided to the end-user with each unit sold/leased in the United States.

## TEST REPORT

### 8.0 MISCELLANEOUS INFORMATION

The miscellaneous information includes details of the test procedure and measured bandwidth.

#### 8.1 Measured Bandwidth

Pursuant to FCC Part 15 Section 15.215(c), the 20dB bandwidth of the emission was contained within the frequency band designed (mentioned as above) which the EUT operated. The effects, if any, from frequency sweeping, frequency hopping, other modulation techniques and frequency stability over expected variations in temperature and supply voltage were considered.

#### 8.2 Emissions Test Procedures

The following is a description of the test procedure used by Intertek Testing Services Hong Kong Ltd. in the measurements of transmitter operating under the Part 15, Subpart C rules.

The transmitting equipment under test (EUT) is placed on a wooden turntable which is four feet in diameter and approximately 0.8m in height above the ground plane for emission measurement at or below 1GHz and 1.5m in height above the ground plane for emission measurement above 1GHz. During the radiated emissions test, the turntable is rotated and any cables leaving the EUT are manipulated to find the configuration resulting in maximum emissions. The EUT is adjusted through all three orthogonal axis to obtain maximum emission levels. The antenna height and polarization are also varied during the testing to search for maximum signal levels. The height of the antenna is varied from one to four meters.

Detector function for radiated emissions is in peak mode. Average readings, when required, are taken by measuring the duty cycle of the equipment under test and subtracting the corresponding amount in dB from the measured peak readings. A detailed description for the calculation of the average factor can be found in Exhibit 8.3.

The frequency range scanned is from the lowest radio frequency signal generated in the device which is greater than 9 kHz to the tenth harmonic of the highest fundamental frequency or 40 GHz, whichever is lower. For line conducted emissions, the range scanned is 150 kHz to 30 MHz.

The EUT is warmed up for 15 minutes prior to the test.

AC power to the unit is varied from 85% to 115% nominal and variation in the fundamental emission field strength is recorded. If battery powered, a new, fully charged battery is used.

Conducted measurements were made as described in ANSI C63.10 (2013).

The IF bandwidth used for measurement of radiated signal strength was 100 kHz or greater when frequency is below 1000 MHz. Where pulsed transmissions of short enough pulse duration warrant, a greater bandwidth is selected according to the recommendations of Hewlett Packard Application Note 150-2. A discussion of whether pulse desensitivity is applicable to this unit is included in this report (See Exhibit 8.1). Above 1000 MHz, a resolution bandwidth of 3 MHz is used.

Transmitter measurements are normally conducted at a measurement distance of three meters. However, to assure low enough noise floor in the forbidden bands and above 1 GHz, signals are acquired at a distance of one meter or less. All measurements are extrapolated to three meters using inverse scaling, unless otherwise reported. Measurements taken at a closer distance are so marked.

**TEST REPORT**

8.2.1 Radiated Emission Test Setup

The figure below shows the test setup, which is utilized to make these measurements.

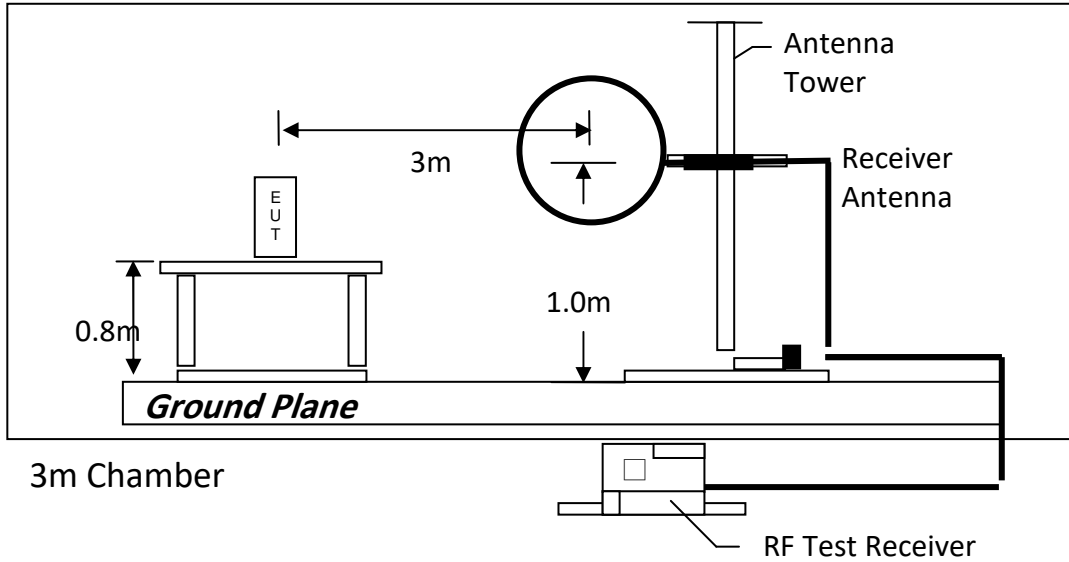

Test setup of radiated emissions up to 30MHz

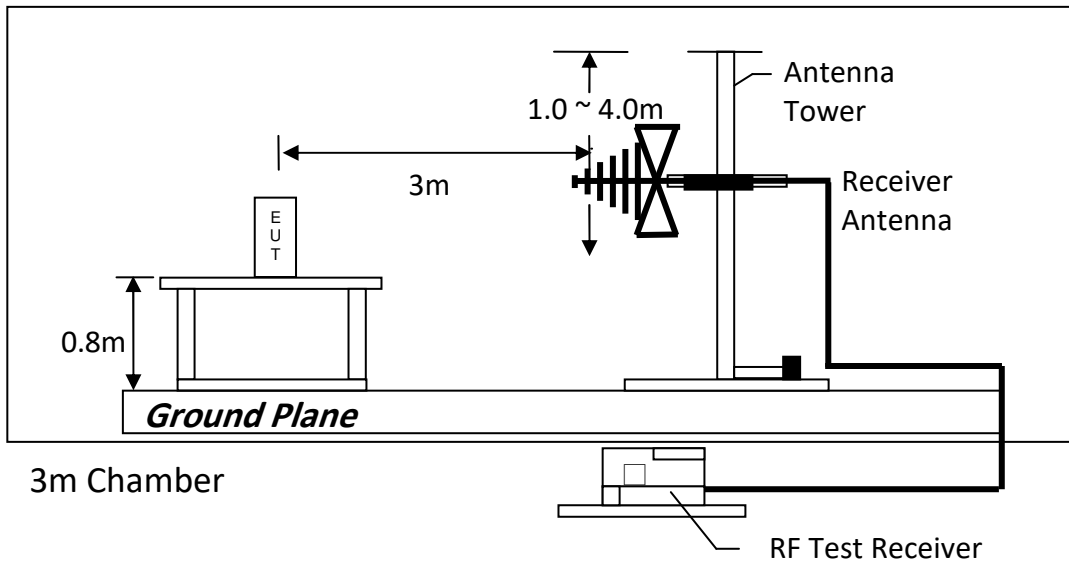

Test setup of radiated emissions above 1GHz

## TEST REPORT

### 8.2.2 Conducted Emission Test Procedures

For tabletop equipment, the EUT along with its peripherals were placed on a 1.0m(W)×1.5m(L) and 0.8m in height wooden table. For floor-standing equipment, the EUT and all cables were insulated, if required, from the ground plane by up to 12 mm of insulating material. The EUT was adjusted to maintain a 0.4 meter space from a vertical reference plane. The EUT was connected to power mains through a line impedance stabilization network (LISN), which provided 50 ohm coupling impedance for measuring instrument and the chassis ground was bounded to the horizontal ground plane of shielded room. The excess power cable between the EUT and the LISN was bundled.

All connecting cables of EUT and peripherals were moved to find the maximum emission.

### 8.2.3 Conducted Emission Test Setup

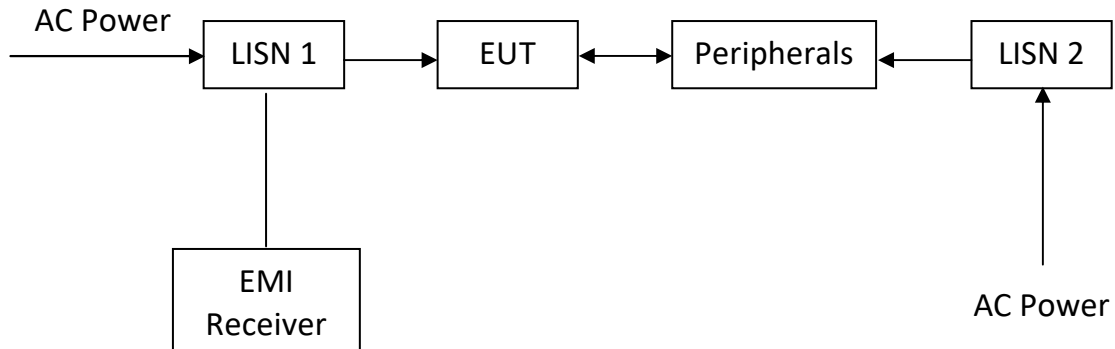



**TEST REPORT**

8.3 Occupied Bandwidth

Occupied Bandwidth Results: 15W Loading

Frequency (MHz)	Occupied Bandwidth (kHz)
127.65MHz	0.72

The worst case is shown as below

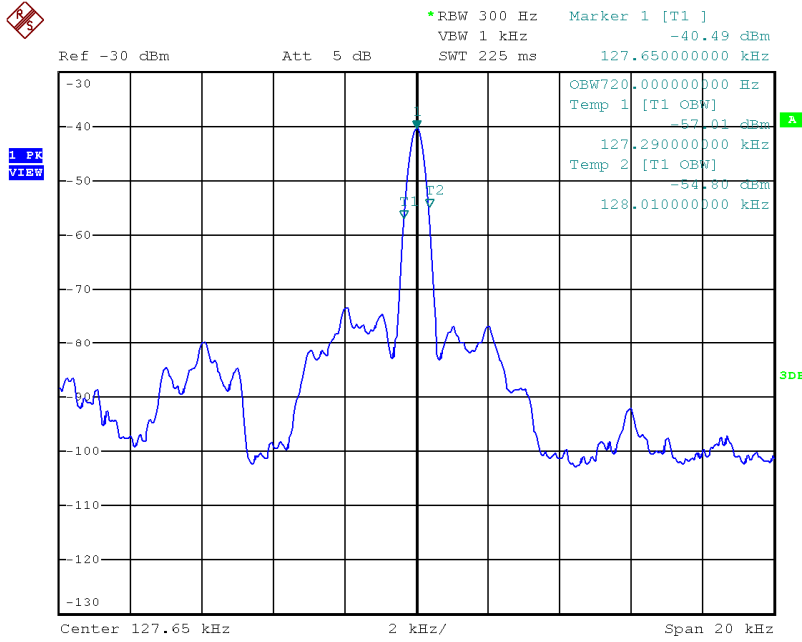

Occupied Bandwidth Results: Standby

Frequency (MHz)	Occupied Bandwidth (kHz)
127.65MHz	2.92

The worst case is shown as below

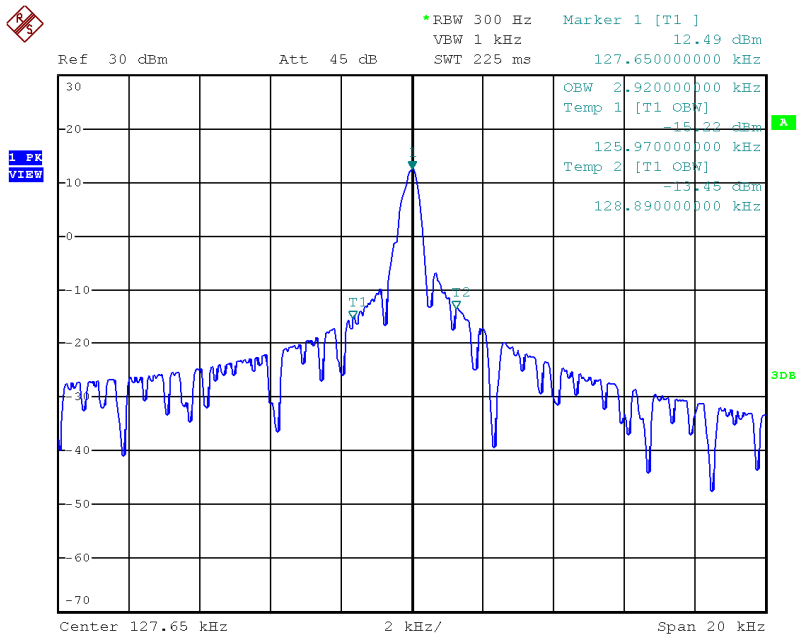

**TEST REPORT**

**9.0 CONFIDENTIALITY REQUEST**

For electronic filing, a preliminary copy of the confidentiality request is saved with filename: request.pdf.

**10.0 EQUIPMENT LIST**

1) Radiated Emissions Test

Equipment	Signal and Spectrum Analyzer (10Hz to 40GHz)	Biconical Antenna (20MHz to 200MHz)	EMI Test Receiver 7GHz
Registration No.	EW-3016	EW-3061	EW-3481
Manufacturer	ROHDESCHWARZ	EMCO	ROHDESCHWARZ
Model No.	FSV40	3142E	ESR7
Calibration Date	October 29, 2021	February 02, 2021	December 21, 2021
Calibration Due Date	October 29, 2022	August 02, 2022	December 21, 2022

Equipment	Log Periodic Antenna	Active Loop H-field (9kHz to 30MHz)
Registration No.	EW-3243	EW-3302
Manufacturer	EMCO	EMCO
Model No.	3148B	6502
Calibration Date	June 03, 2021	December 13, 2021
Calibration Due Date	December 30, 2022	June 13, 2023

Equipment	RF Preamplicifier (9kHz to 6000MHz)	14m Double Shield RF Cable (20MHz to 6GHz)
Registration No.	EW-3006b	EW-2074
Manufacturer	SCHWARZBECK	RADIALL
Model No.	BBV9718	N(m)-RG142-BNC(m) L=14M
Calibration Date	November 25, 2019	November 14, 2019
Calibration Due Date	June 25, 2022	August 14, 2022

## TEST REPORT

### 2) Conducted Emissions Test

Equipment	RF Cable 240cm (RG142) (9kHz to 30MHz)	Artificial Mains Network	EMI Test Receiver
Registration No.	EW-2454	EW-2501	EW-2500
Manufacturer	RADIALL	ROHDESCHWARZ	ROHDESCHWARZ
Model No.	Bnc m st / 142 / bnc mra 240cm	ENV-216	ESCI
Calibration Date	January 26, 2022	November 09, 2021	March 29, 2021
Calibration Due Date	January 26, 2023	November 09, 2022	June 29, 2022

### 3) OBW Measurement

Equipment	Spectrum Analyzer
Registration No.	EW-2466
Manufacturer	ROHDESCHWARZ
Model No.	FSP30
Calibration Date	November 18, 2019
Calibration Due Date	August 18, 2022

### 4) Control Software for Radiated Emission

Software Information	
Software Name	EMC32
Manufacturer	ROHDESCHWARZ
Software version	10.50.40

**END OF TEST REPORT**