

Installation and Operation manual: REX0150-L-S Exit Button

The REX0150-L-S is a multiple function surface mount Infrared Contactless Exit Button with the following two unique features:

1. Power Supply Options: Use battery power.

Exit button's Physical size(mm): 118.24(L)x74.24(W)x17.1(H)

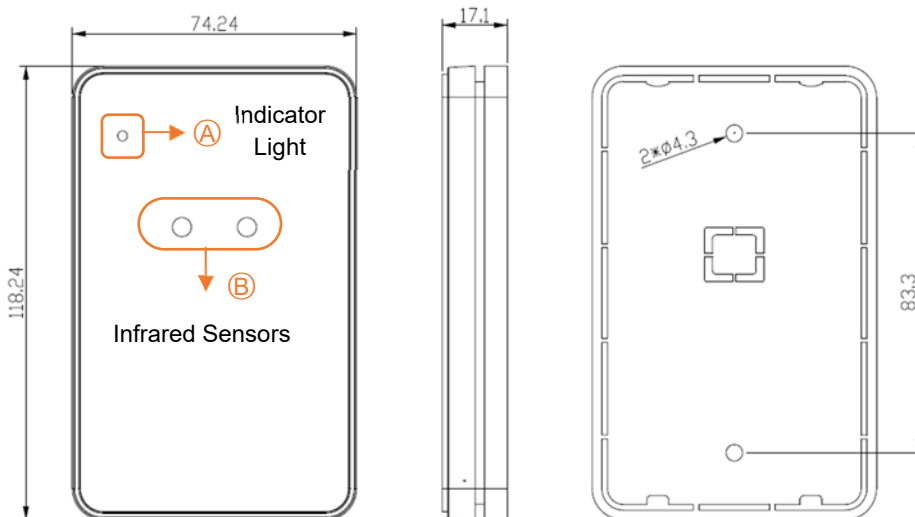

Function:

- When the trigger is successfully detected on Infrared Sensor(as shown above in Figure®) to the exit button, the relay is activated with its Indicator Light(as shown above in Figure®) turning from blue to green, and the buzzer beeping once. After 0.8 seconds, the relay will be turned off automatically, and the Indicator Light(Figure®) will return to the initial state. (If the trigger stays within the contact sensor without any movement, there will be consistent trigger with the continuous buzzer beep).
- Battery power supply
 - Normal state (Voltage $\geq 2.5V$): The Exit button's Indicator Light(Figure®) flashing Blue. The successful trigger will start the relay and turn off automatically after 0.8 seconds.
 - Abnormal state (Voltage $< 2.5V$): The Exit button's Indicator Light(Figure®) flashing Red. It is time to change for the new set of AAA battery.
- The buzzer can be turned on or off. Refer to the "DIP switch setting of exit button" table on page 4.

Receiver

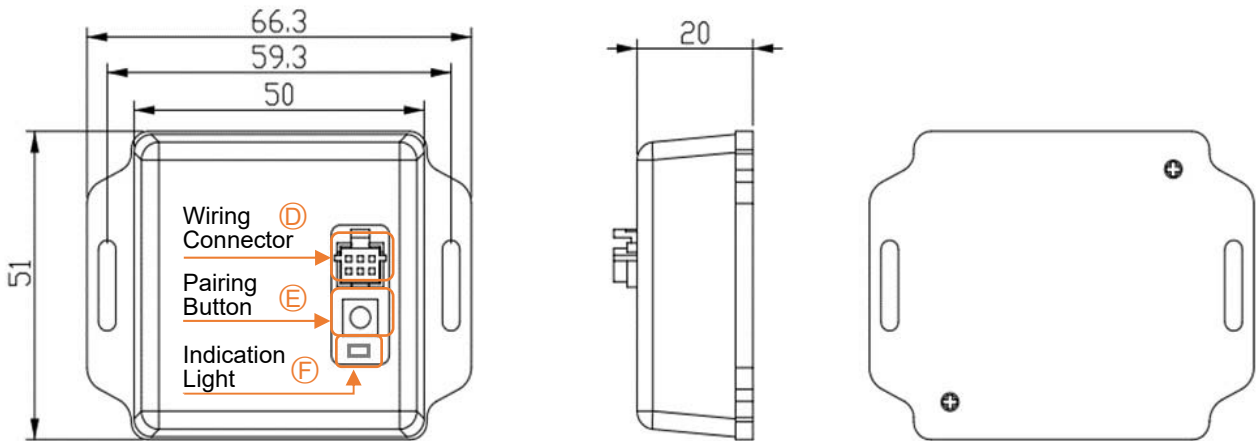

- Optional: For wireless installation of the exit button, a receiver can be added. One unit of receiver can support up to five units of exit button(if needed).
 - When communication to the receiver is successful: the relay is activated at the receiver's side, and the exit button's Indicator Light(FigureⒶ) will turn from blue to green with the buzzer beeping once. The receiver's Indicator Light(as shown above in FigureⒺ) will change to the fast speed flashing green.
 - When communication to the receiver is NOT successful, the trigger is not detected, and the relay will not be activated at the receiver's side. The receiver's Indicator Light(FigureⒺ) will remain at normal speed flashing green.

Pairing:

- Activate Pairing: Once the receiver is powered on, its Indicator Light (as shown in FigureⒺ) will flash in green slowly at default. The buzzer sounds several times to indicate that several buttons are paired. In order to pair up the receiver with the exit button, follow these 2 steps:
 - a) Press the Pairing button(as shown in FigureⒺ) for 2~4 seconds. The buzzer will beep once with the green light flashing quickly for 10 seconds.
 - b) Within 10 seconds while the green light is flashing quickly, trigger the exit button once. (if you miss out 10 seconds, the pairing will be automatically terminated and you must restart this setup from the beginning).

The pairing is confirmed by the receiver beeping the buzzer once. Subsequently, everytime the exit button is triggered, the receiver's Indicator Light(as shown in FigureⒺ) will have the green light flashing quickly for 3 seconds. Then, its flashing speed will return to its initial state of slow speed.

- Disconnect Pairing: press the Pairing button(as shown in FigureⒺ) for more than 10 seconds. The pairing disconnection is confirmed when the buzzer beeps two times: first with short beep followed by the second long beep.
- Pairing failure indication:
 - a) Even when the exit button is triggered, the receiver will not react. Its green light will remain flashing slowly at its default.
 - b) One unit of receiver can support up to 5 units of exit button. If the number of pairing exceeds the upper limit(more than 5 exit buttons), the buzzer will beep three times.

Note: Don't wave too fast or you won't be able to trigger the button

Inside View of the Exit Button

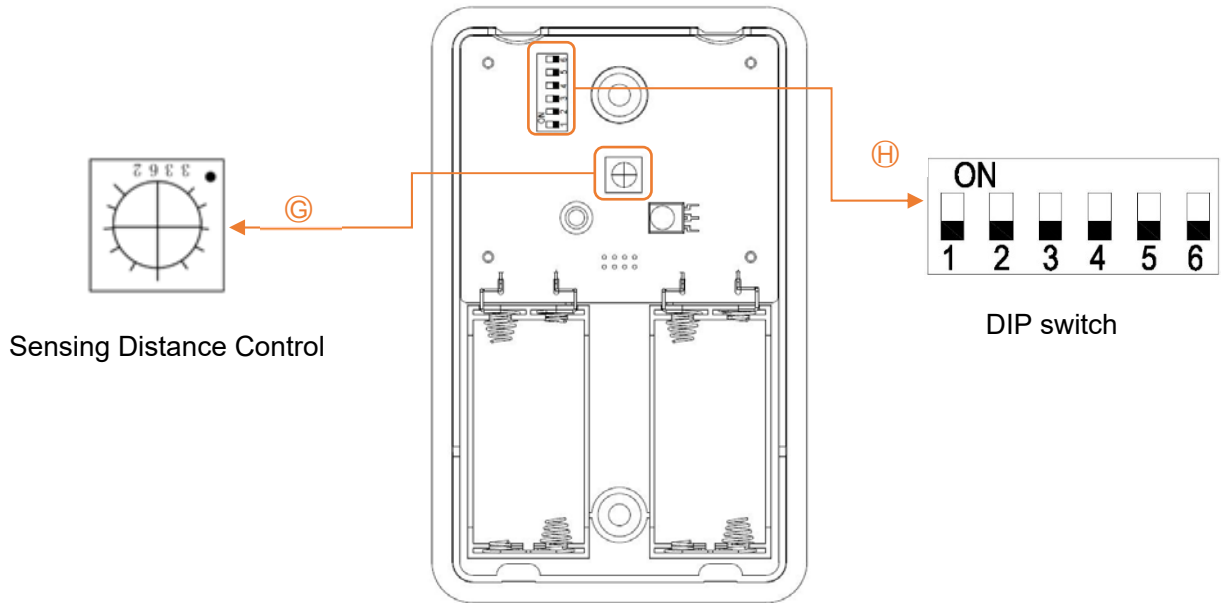

DIP switch (Figure ⑥) setting of exit button:

1	N/A	N/A	N/A
2	Buzzer	on	Turn on the buzzer
		off	Turn off the buzzer
3	wireless communications	on	Turn on wireless communication
		off	Turn off wireless communication
4	Relay	on	Open relay
		off	Turn off the relay
5	Pairing control	on	Enable pairing
		off	Disable pairing
6	Relay working status switch	on	Valid when powered by 12VDC, ON output
		off	NC output, this switch is invalid when powered by battery, fixed to normally open mode when powered by battery

Sensing Distance Control:

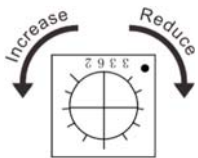

To adjust the Infrared sensing distance, use the appropriate tool to rotate the middle cross knob(as shown above in Figure G).

- Increase IR sensing distance: Turn the knob counterclockwise.
- Reduce the IR sensing distance: Turn the knob clockwise.

Note: the infrared sensing distance is related to the power supply voltage.

- When the battery power drops, the sensing distance will also decrease causing unstable power supply. Therefore, the resistance cannot be adjusted to the shortest distance as its sensor may not be triggered normally.
- On the other hand, when the power supply is used, it offers the stable sensing distance. When the sensing distance is adjusted to the shortest distance, the sensor can be triggered consistently at normal condition.

Receiver: Wiring Connector(Figure ⑩) Instruction

No.	Mark	Colour	Description
1	NC	purple	Normally closed
2	COM	orange	Public port
3	NO	brown	Normally open
4	GND	black	Grounded / -
5	GND	black	Grounded / -
6	VIN	red	Power input, 3V DC / +

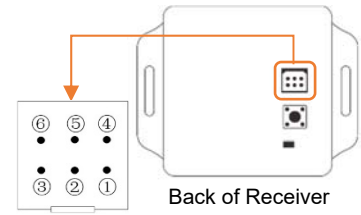

Back of Receiver
Figure ⑩ on page 2

Specification:

Exit Button:	
Operating voltage	3V DC
Standby current	50uA
Operating current	<50mA
2.4G Emission current	<25mA
Battery Powered Life(Ideal)	2 AAA batteries : 6 months (Standby or Induce 200 times/day) 4 AAA batteries : 1 year (Standby or Induce 200 times/day)
Operating temperature(℃)	0 ~40
Panel material	Stainless
Receiver:	
Operating voltage (V)	3V DC
Operating current	12mA ~ 70mA / 12VDC
Operating temperature(℃)	-30 ~70
Operating environment humidity (%)	10~ 90%
Communication distance between modules	Maximum 30m (Open area)
Reading range	5 ~20cm
Operating mode	1 Receiver can be matched up to 5 Exit Buttons

Function and state:

Module	Function	State	Description
Exit Button	Standby	Flashing Blue light	Voltage $\geq 2.5V$
		Flashing Red light	Voltage $< 2.5V$
	Induction	Flashing Green light once Buzzer beeps briefly once	Trigger successful
		Flashing Red light once Buzzer beeps twice	Failed to communicate with Receiver
Wireless Receiver	Standby	Green light flashing slowly	After power on
	Induction	Green light flashing fast for 0.8 seconds Buzzer beeps once Relay is activated and then turn off automatically after 0.8 seconds	Trigger successful

Installation instructions:

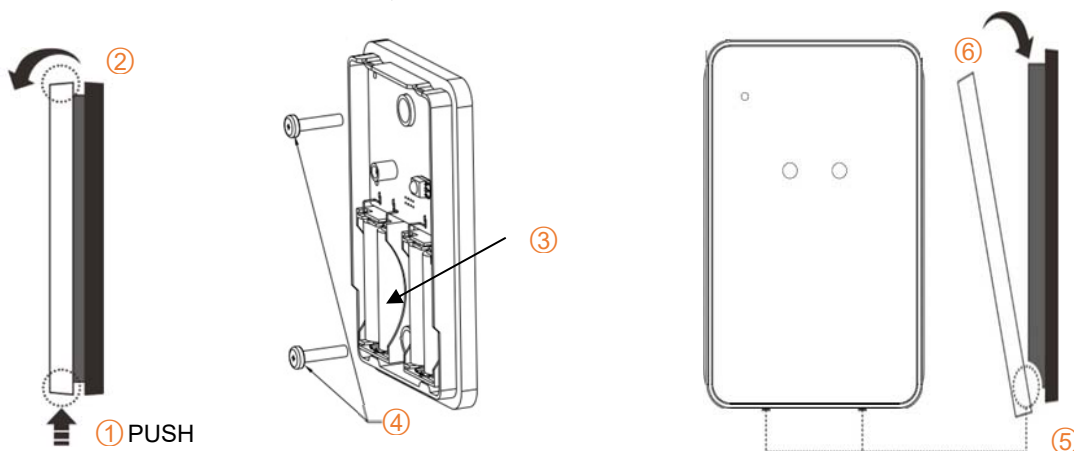

Exit button

- Open the front panel by following these 2 steps:
 - Hold the exit button on the upright position.
 - Push up the bottom of the front panel cover (as shown above in figure ①) while pulling out the upper side away from the back panel (as shown above in figure ②).

Warning: Trying to force open without lifting up the bottom of the front panel cover can damage the teeth (figure ⑤).
- If powered by the batteries: 2 or 4 AAA batteries need to be added. It contains two sets of battery compartment (as shown above in figure ③). If only 2 batteries are installed, only one compartment can be used. If the power is supplied directly using wires, plug in the wires provided to the wiring connector (see figure ④ on page 1) on the back of the exit button.
- Fix the back panel body with two screws provided (as shown above in figure ④).
- To cover the front panel, place the bottom of the front panel on the teeth first to snap (as shown above in figure ⑤), then press the upper part (as shown above in figure ⑥) of the panel by hand to mount the entire panel.
- When the power is connected, the exit button enters into the standby mode.

FCC Statement

Any Changes or modifications not expressly approved by the party responsible for compliance could void the user's authority to operate the equipment.

This device complies with part 15 of the FCC Rules. Operation is subject to the following two conditions:

- (1) This device may not cause harmful interference, and
- (2) This device must accept any interference received, including interference that may cause undesired operation.

This equipment complies with FCC radiation exposure limits set forth for an uncontrolled environment .

Note : This equipment has been tested and found to comply with the limits for a Class B digital device, pursuant to part 15 of the FCC Rules. These limits are designed to provide reasonable protection against harmful interference in a residential installation. This equipment generates,uses and can radiate radio frequency energy and, if not installed and used in accordance with the instructions, may cause harmful interference to radio communications. However, there is no guarantee that interference will not occur in a particular installation. If this equipment does cause harmful interference to radio or television reception, which can be determined by turning the equipment off and on, the user is encouraged to try to correct the interference by one or more of the following measures:

- Reorient or relocate the receiving antenna.
- Increase the separation between the equipment and receiver.
- Connect the equipment into an outlet on a circuit different from that to which the receiver is connected.
- Consult the dealer or an experienced radio/TV technician for help.

This device complies with Innovation, Science, and Economic Development Canada licence-exempt RSS standard(s). Operation is subject to the following two conditions:

- 1) this device may not cause interference, and
- 2) this device must accept interference, including interference that may cause undesired operation of the device.

Le présent appareil est conforme aux CNR d'Innovation, Sciences et Développement économique Canada applicables aux appareils radio exempts de licence. L'exploitation est autorisée aux deux conditions suivantes :

- (1) l'appareil n' doit pas produire de brouillage, et*
- (2) l'utilisateur de l'appareil doit accepter tout brouillage radioélectrique subi, même si le brouillage est susceptible d'en compromettre le fonctionnement.*

The device is compliance with RF exposure guidelines, users can obtain Canadian information on RF exposure and compliance.

Le présent appareil est conforme Après examen de ce matériel aux conformité ou aux limites d'intensité de champ RF, les utilisateurs peuvent sur l'exposition aux radiofréquences et la conformité and compliance d'acquérir les informations correspondantes.