

Company Name: Shanghai Smarfid Security Equipment Co., Ltd.
 Add: : #102, Building 12, No.1088 Zhongchun Road, Minhang District, Shanghai, 201109, China
 Tel: +86-021-54260132
 Fax: +86-021-54260132
 E-mail: sharon.sheng@smarfid.com

DECLARATION

Date: 2024-02-10

FEDERAL COMMUNICATIONS COMMISSIONS
 Authorization and Evaluation Division
 7435 Oakland Mills Road
 Columbia MD 21046

We, Shanghai Smarfid Security Equipment Co., Ltd.. hereby declare that product name: Contactless Exit Button(FCC ID: X3A-REX0150-L ,model: REX0159-L-B ,Series model: REX0150-L-B, REX0150-L-S, REX0159-L-S) are electrically identical with the PCB design, components and electromagnetic compatibility characteristics, and model: REX0159-L-B has been tested by Bay Area Compliance Laboratories Corp. (Kunshan).





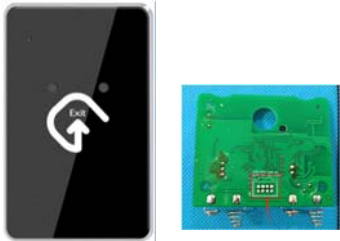

The differences of them are as follows:

REX0150-L-B & REX0150-L-S: DC 3V powered from battery

REX0159-L-B & REX0159-L-S: DC 12V or DC 3V powered from battery

1. REX0150-L-B is a contactless exit button which contains the 2.4G transmit module, it is powered by battery.and acrylic panel
2. REX0159-L-B is a contactless exit button which contains the 2.4G transmit module, it has a terminal on the board. and acrylic panel
3. REX0150-L-S is a contactless exit button which contains the 2.4G transmit module, it is powered by battery.and stainless steel panel
4. REX0159-L-S is a contactless exit button which contains the 2.4G transmit module, it has a terminal on the board. and stainless steel panel

REX0150-L-B	Contactless exit button with 2.4G transmitter without terminal& acrylic panel	
-------------	---	---

REX0159-L-B	Contactless exit button with 2.4G transmitter with terminal& acrylic panel		
REX0150-L-S	Contactless exit button with 2.4G transmitter without terminal&stainless steel panel		
REX0159-L-S	Contactless exit button with 2.4G transmitter with terminal&stainless steel panel		

1. Circuitry difference of non-RF boards.

The non-RF boards of REX0150-L-B,REX0150-L-S have no terminal JP1, the non-RF boards of REX0159-L-B,REX0159-L-S have terminal JP1.

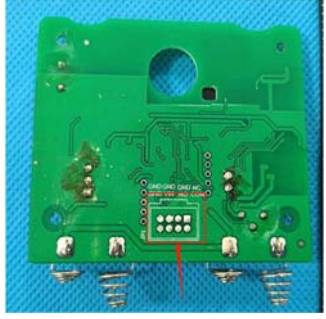
REX0159-L-B,REX0159-L-S	REX0150-L-B,REX0150-L-S
	

2. Circuitry difference of RF boards.

The RF boards of REX0150-L-B,REX0159-L-B,REX0150-L-S,REX0159-L-S are all the same.

3. Describe the exterior casing and color differences (if applicable).

REX0150-L-B,REX0159-L-B they're black acrylic panels
 REX0150-L-S,REX0159-L-S they're white stainless steel panel

4.If no differences, provide the reason(s) for obtaining multiple PMN(s)/HVIN(s)/FVIN(s).

The HVIN of REX0150-L-B is REX TX V1.4-REX0150-L-B
 The HVIN of REX0159-L-B is REX TX V1.4-REX0159-L-B
 The HVIN of REX0150-L-S is REX TX V1.4-REX0150-L-S

The HVIN of REX0159-L-S is REX TX V1.4-REX0159-L-S

5. If family contains multiple versions for marketing purposes, detail the marketing detail differences such as names of distribution chains, packaging information, labeling information, etc...

N/A

6. If submitting multiple versions for future intro on market, provide future market launch plans and why not postponing certification of product versions not ready for market.

N/A

7. If chosen PMN or HVIN are already on the market in other countries but the devices are not identical to what is provided in the Canadian application, provide justification.

N/A

8. Provide internal & external photos for each product version.

Please find attached

9. Provide manual and product labels for each product version.

Please find attached

Please contact me if there is need for any additional clarification or information.

Best Regards,

Signature:

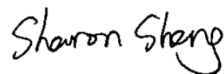

Printed Name: Sharon Sheng

Title: Manager