



Test Report

Product Name	CAMINO-101 Class B AIS Transponder
Model No.	CAMINO-101

Applicant	Alltek Marine Electronics Corp.
Address	7F, No.605, Ruei Guang Rd., Neihu, Taipei, Taiwan, 114 R.O.C.

Date of Receipt	Oct. 22, 2009
Issued Date	Apr. 15, 2010
Report No.	103371R-RFCEP69V01-A
Report Version	V1.0

The test results relate only to the samples tested.
 The test report shall not be reproduced except in full without the written approval of Quietek Corporation.

Test Report Certification

Issued Date : Apr. 15, 2010

Report No. : 103371R-RFCEP69V01-A



Product Name	CAMINO-101 Class B AIS Transponder
Applicant	Alltek Marine Electronics Corp.
Address	7F, No.605, Ruei Guang Rd., Neihu, Taipei, Taiwan, 114 R.O.C.
Manufacturer	Alltek Marine Electronics Corp.
Model No.	CAMINO-101
EUT Rated Voltage	DC 10~28V
EUT Test Voltage	DC 24V
Trade Name	AMEC
Applicable Standard	ETSI EN 300 440-1:V1.4.1 (2008-05) ETSI EN 300 440-2:V1.2.1 (2008-05)
Test Result	Complied

The test results relate only to the samples tested.

The test report shall not be reproduced except in full without the written approval of QuieTek Corporation.

Documented By : Leven Huang
(Adm. Specialist / Leven Huang)

Tested By : Molin Huang
(Engineer / Molin Huang)

Approved By : Vincent Lin
(Manager / Vincent Lin)



TABLE OF CONTENTS

Description	Page
1. General Information	4
1.1. EUT Description	4
1.2. Test Mode	4
1.3. Tested System Details.....	5
1.4. Configuration of tested System	5
1.5. EUT Exercise Software	6
1.6. Test Facility	7
2. Spurious radiation (Receiver)	8
2.1. Test Equipment.....	8
2.2. Test Setup	9
2.3. Test Condition	10
2.4. Limits.....	10
2.5. Test Procedure	10
2.6. Test Specification	10
2.7. Test Result	11
2.8. Test Photo	13
Attachement.....	15
EUT Photograph.....	15

1. General Information

1.1. EUT Description

Product Name	CAMINO-101 Class B AIS Transponder
Trade Name	AMEC
Model No.	CAMINO-101
Frequency Range	1575.42MHz
Number of Channel(s)	1
Type of Modulation	Phase Modulation
Channel Control	Auto

NOTE: Hardware: M-PCB-AISCTL01P52 , M-PCB-AISPF03P51 ; Software: Version 1.0

Working Frequency of Each Channel	
Channel	Frequency
01	1575.42MHz

Note:

1. The EUT is CAMINO-101 Class B AIS Transponder with a built-in GPS receiver at 1575.42MHz (L1).

1.2. Test Mode

QuieTek verified the construction and function in typical operation. All the test modes were carried out with the EUT in normal operation, which was shown in this test report and defined as:

Pre-Test Mode	
	Mode 1: GPS Receiver
Final Test Mode	
	Mode 1: GPS Receiver

1.3. Tested System Details

The types for all equipment, plus descriptions of all cables used in the tested system (including inserted cards) are:

	Product	Manufacturer	Model No.	Serial No.	Power Cord
(1)	GPS Simulator	IFR	GPS-101-2	264007013	Non-Shielded, 1.8m
(2)	Notebook PC	DELL	PP18L	42649348672	Non-Shielded, 1.8m
(3)	VHF Antenna	Wintec	N/A	N/A	N/A
(4)	GPS Antenna	whayu	N/A	N/A	N/A
(5)	Horn Antenna	IFR	N/A	N/A	N/A
(6)	DC Power Supply	Agilent	E3446	MY40003414	Non-Shielded, 1.8m

	EUT Cable Type	Signal cable Description
A.	RS-232 Cable	Shielded, 1.2m
B.	VHF Antenna Cable	Shielded, 10m
C.	GPS Antenna Cable	Shielded, 10m
D.	Power Cable	Shielded, 1.5m

	Signal Cable Type	Signal cable Description
E.	Coaxial Cable	Shielded, 1.5m

1.4. Configuration of tested System

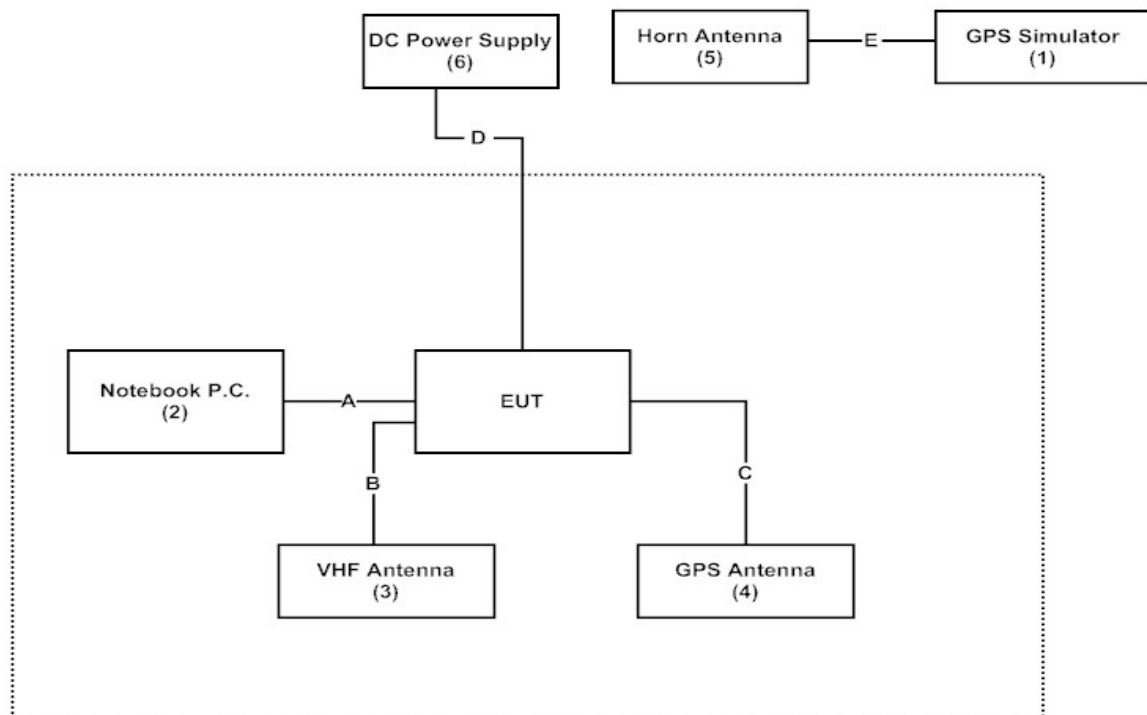

1.5. EUT Exercise Software

1	Setup the EUT as shown in section 1.4.
2	Execute the GPS test software on the Notebook.
3	Verify that the EUT works properly.

1.6. Test Facility

Ambient conditions in the laboratory:

Items	Required	Actual
Temperature (°C)	15-35	20-35
Humidity (%RH)	25-75	50-65
Barometric pressure (mbar)	860-1060	950-1000

The related certificate for our laboratories about the test site and management system can be downloaded from Quietek Corporation's Web Site :

<http://tw.quietek.com/tw/emc/accreditations/accreditations.htm>

The address and introduction of Quietek Corporation's laboratories can be founded in our Web site :

<http://www.quietek.com/>

Site Description: Accreditation on NVLAP
NVLAP Lab Code: 200533-0



Accreditation on DNV
Statement No. : 413-99-LAB11



Accredited by TUV Rheinland
Certificate No.: 10011438-1-2009



Accreditation on Nemko
Certificate No.: ELA 165



Site Name: Quietek Corporation
Site Address: No. 5-22, Ruei-Shu Valley, Ruei-Ping Tsuen,
Lin-Kou Shiang, Taipei,
Taiwan, R.O.C.
TEL : 886-2-8601-3788 / FAX : 886-2-8601-3789
E-Mail : service@quietek.com



2. Spurious radiation (Receiver)

2.1. Test Equipment

The following test equipment are used during the test:

Item		Equipment	Manufacturer	Model No. / Serial No.	Last Cal.
1	X	Test Receiver	R & S	ESI 26 / 838786/004	May, 2009
2	X	Spectrum Analyzer	Agilent	E4407B / US39440758	May, 2009
3	X	Bilog Antenna	SCHAFFNER	CBL6112B / 2697	May, 2009
4	X	Horn Antenna	Schwarzbeck	BBHA9120D / 305, 306	July, 2009
5	X	Horn Antenna	Schwarzbeck	BBHA9170 / 208, 209	July, 2009
6	X	Pre-Amplifier	QTK	QTK-AMP-01 / 0001	July, 2009
7	X	Pre-Amplifier	QTK	QTK-AMP-03 / 0003	May, 2009
8	X	Pre-Amplifier	HP	8449B / 3008A01123	July, 2009
9		No.3 OATS			

- Note:
1. All equipments are calibrated every one year.
 2. The test instruments marked by "X" are used to measure the final test results.

2.2. Test Setup

Under 1GHz Test Setup:

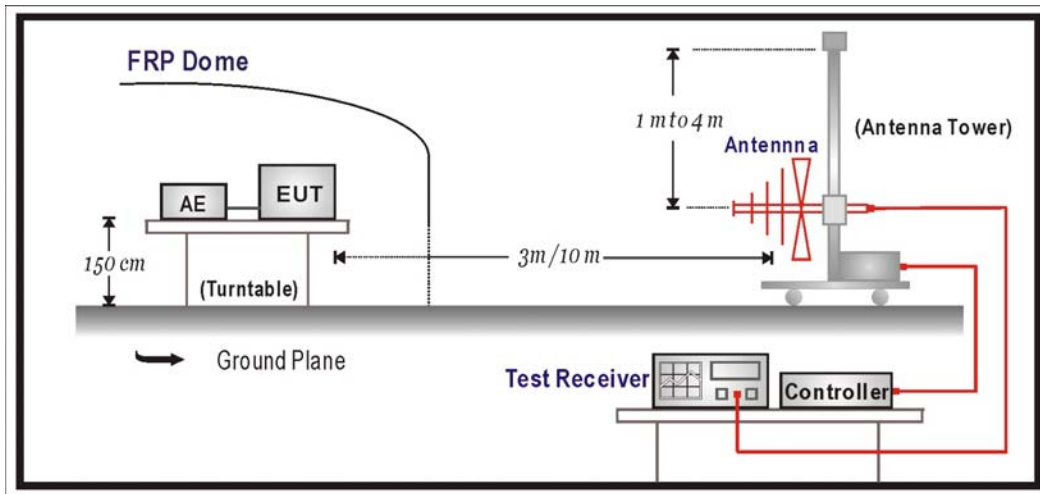

Above 1GHz Test Setup:

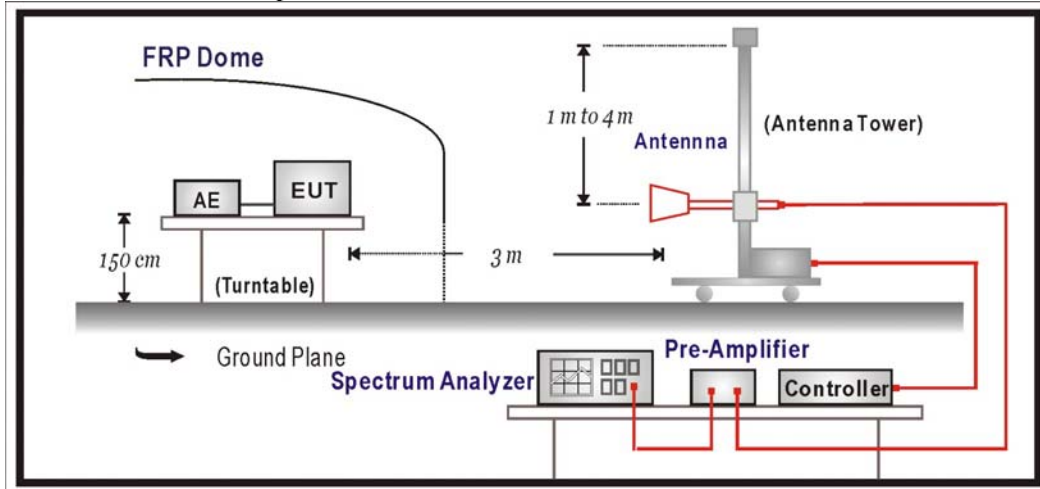

2.3. Test Condition

Standard Temperature and Humidity, Standard Test Voltage

2.4. Limits

The power of any spurious emission, radiated or conducted, shall not exceed the values given below:

- 2 nW below 1000 MHz
- 20 nW above 1000 MHz

2.5. Test Procedure

The EUT and its simulators are placed on a turn table which is 1.5 meters above ground. The turn table can rotate 360 degrees to determine the position of the maximum emission level. The EUT was positioned such that the distance from antenna to the EUT was 3 meters. The antenna can move up and down between 1 meter and 4 meters to find out the maximum emission level.

Broadband antenna (calibrated bi-log and horn antenna) are used as a receiving antenna.

Both horizontal and vertical polarization of the antenna are set on measurement. And a high frequency preamplifier were used increase the sensitivity of the measuring. In order to find the maximum emission, all of the interface cables must be manipulated according to ETSI EN 300 440-1: V1.4.1 (2008-05), ETSI EN 300 440-2:V1.2.1 (2008-05) on radiated measurement.

The additional notch filter below 1GHz was used to measure the level of harmonics radiated emission during field strength of harmonics measurement. The bandwidth setting on the field strength meter is 1 MHz.

2.6. Test Specification

According to ETSI EN 300 440-1:V1.4.1 (2008-05), ETSI EN 300 440-2:V1.2.1 (2008-05)

2.7. Test Result

Product	CAMINO-101 Class B AIS Transponder		
Test Mode	Mode 1: GPS Receiver		
Test Condition	Spurious emissions		
Date of Test	2009/10/23	Test Site	No.3 OATS

Channel 1

Frequency (MHz)	Emission Level (dBm)	Reading Level (dBm)	Measure Level (dB)	Margin (dB)	Limit (dBm)
=====					
Peak Detector (Horizontal)					
325.880	2.844	-68.385	-65.541	-8.541	-57.000
498.110	6.874	-78.200	-71.326	-14.326	-57.000
553.680	7.272	-73.050	-65.778	-8.778	-57.000
626.880	7.300	-71.800	-64.500	-7.500	-57.000
888.590	9.563	-72.600	-63.037	-6.037	-57.000
905.425	9.830	-75.300	-65.470	-8.470	-57.000
1324.000	8.264	-70.290	-62.026	-15.026	-47.000
1570.000	6.909	-71.620	-64.711	-17.711	-47.000
2120.000	10.338	-72.250	-61.912	-14.912	-47.000
3228.000	12.481	-74.590	-62.109	-15.109	-47.000

Note:

1. “ ” means the worst emission level.
2. Emission Level = Reading Level + Correction Factor

Product	CAMINO-101 Class B AIS Transponder		
Test Mode	Mode 1: GPS Receiver		
Test Condition	Spurious emissions		
Date of Test	2009/10/23	Test Site	No.3 OATS

Channel 1

Frequency (MHz)	Emission Level (dBm)	Reading Level (dBm)	Measure Level (dB)	Margin (dB)	Limit (dBm)
=====					
Peak Detector (Vertical)					
245.967	-0.952	-68.200	-69.152	-12.152	-57.000
322.800	1.861	-67.600	-65.739	-8.739	-57.000
507.725	5.983	-75.400	-69.417	-12.417	-57.000
533.950	5.916	-70.400	-64.484	-7.484	-57.000
832.500	8.892	-76.600	-67.708	-10.708	-57.000
910.990	8.555	-75.400	-66.845	-9.845	-57.000
1255.000	8.360	-64.400	-56.040	-9.040	-47.000
1580.000	7.484	-67.290	-59.806	-12.806	-47.000
2464.000	11.523	-68.950	-57.427	-10.427	-47.000
3556.000	13.759	-68.620	-54.861	-7.861	-47.000

Note:

1. “ ” means the worst emission level.
2. Emission Level = Reading Level + Correction Factor

2.8. Test Photo

Test Mode : Mode 1: GPS Receiver

Description : Front View of Spurious emissions Test

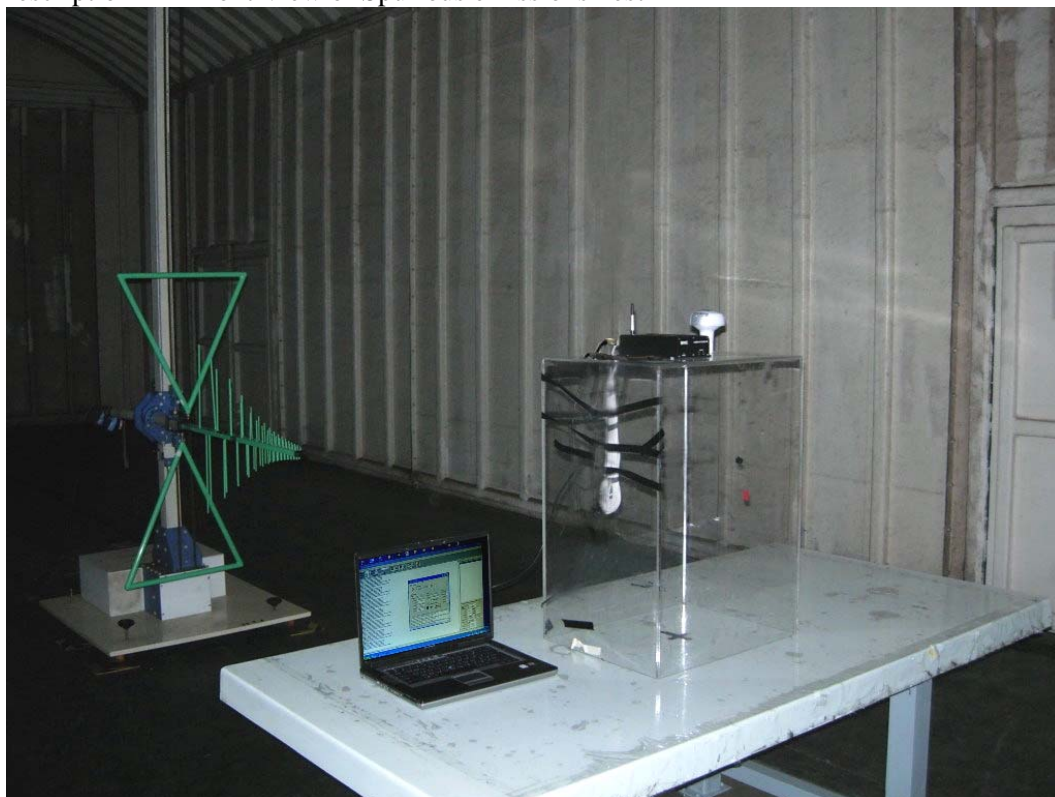

Test Mode : Mode 1: GPS Receiver

Description : Back View of Spurious emissions Test



Test Mode : Mode 1: GPS Receiver

Description : Front View of Spurious emissions Test-Horn

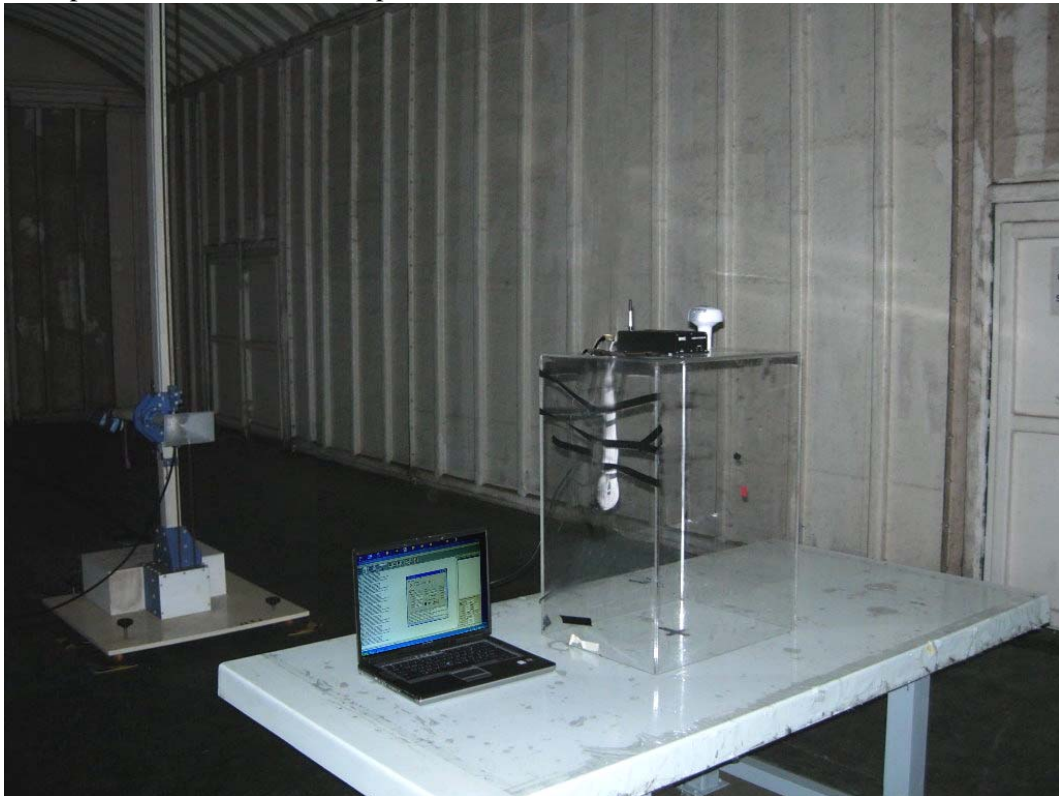

Test Mode : Mode 1: GPS Receiver

Description : Back View of Spurious emissions Test-Horn

