



# Radio Test Report

**Issued Date** : Aug. 23, 2011  
**Project No.** : R1105011  
**Equipment** : AIS Aids to Navigation (AtoN)  
**Model Name** : MANDO-301; MANDO-302;  
MANDO-303  
**Applicant** : Alltek Marine Electronics Corp.  
**Address** : 7F, NO. 605, Ruei Guang Rd., NeiHu,  
Taipei, Taiwan, R.O.C. 114

**Tested by:** Neutron Engineering Inc. EMC Laboratory  
**Date of Receipt:** Jun. 14, 2011  
**Date of Test:** Jun. 14, 2011 ~ Jun. 20, 2011

**Testing Engineer** Gary Chou  
(Gary Chou)

**Technical Manager** : Jeff Yang  
(Jeff Yang)

**Authorized Signatory** : Andy Chiu  
(Andy Chiu)

**Neutron Engineering Inc.**  
B1, No. 37, Lane 365, YangGuang St.,  
NeiHu District 114, Taipei, Taiwan.  
TEL: +886-2-2657-3299  
FAX: +886-2-2657-3331



### **Declaration**

**Neutron** represents to the client that testing is done in accordance with standard procedures as applicable and that test instruments used has been calibrated with the standards traceable to National Measurement Laboratory (**NML**) of **R.O.C.**, or National Institute of Standards and Technology (**NIST**) of **U.S.A.**

**Neutron's** reports apply only to the specific samples tested under conditions. It is manufacture's responsibility to ensure that additional production units of this model are manufactured with the identical electrical and mechanical components. **Neutron** shall have no liability for any declarations, inferences or generalizations drawn by the client or others from **Neutron** issued reports.

**Neutron's** reports must not be used by the client to claim product endorsement by the authorities or any agency of the Government.

This report is the confidential property of the client. As a mutual protection to the clients, the public and **Neutron-self**, extracts from the test report shall not be reproduced except in full with **Neutron's** authorized written approval.

**Neutron's** laboratory quality assurance procedures are in compliance with the **ISO Guide 17025** requirements, and accredited by the conformity assessment authorities listed in this test report.

### **Limitation**

For the use of the authority's logo is limited unless the Test Standard(s)/Scope(s)/Item(s) mentioned in this test report is (are) included in the conformity assessment authorities acceptance respective.



<b>Table of Contents</b>	<b>Page</b>
<b>1 . CERTIFICATION</b>	<b>4</b>
<b>2 . RFI EMISSIONS MEASUREMENT</b>	<b>5</b>
2.1 TEST FACILITY	5
2.2 MEASUREMENT UNCERTAINTY	5
2.3 TEST CONDITIONS AND CHANNEL	5
2.4 TEST METHODOLOGY AND RESULTS	7
<b>3 . GENERAL INFORMATION</b>	<b>9</b>
3.1 GENERAL DESCRIPTION OF EUT	9
3.2 DESCRIPTION OF TEST MODES	10
3.3 BLOCK DIAGRAM SHOWING THE CONFIGURATION OF SYSTEM TESTED	11
3.4 DESCRIPTION OF SUPPORT UNITS	12
3.5 EUT OPERATING CONDITIONS	12
<b>4 . SPURIOUS EMISSIONS – RECEIVER (30 - 1000MHz)</b>	<b>13</b>
4.1 APPLIED PROCEDURES / LIMIT	13
4.1.1 MEASUREMENT INSTRUMENTS LIST	13
4.1.2 MEASURING INSTRUMENTS AND SETTING	13
4.1.3 TEST PROCEDURE	14
4.1.4 DEVIATION FROM TEST STANDARD	14
4.1.5 TEST SETUP LAYOUT	14
4.1.6 EUT OPERATING CONDITIONS	14
4.1.7 RESULTS OF STANDBY MODE SPURIOUS EMISSIONS	14
4.1.8 TEST RESULTS	15
<b>5 . SPURIOUS EMISSIONS – RECEIVER (ABOVE 1000MHz)</b>	<b>17</b>
5.1 APPLIED PROCEDURES / LIMIT	17
5.1.1 MEASUREMENT INSTRUMENTS LIST	17
5.1.2 MEASURING INSTRUMENTS AND SETTING	17
5.1.3 TEST PROCEDURE	18
5.1.4 DEVIATION FROM TEST STANDARD	18
5.1.5 TEST SETUP LAYOUT	18
5.1.6 EUT OPERATING CONDITIONS	18
5.1.7 RESULTS OF STANDBY MODE SPURIOUS EMISSIONS	18
5.1.8 TEST RESULTS	19
<b>6 . EUT TEST PHOTO</b>	<b>21</b>



## 1. CERTIFICATION

Equipment : AIS Aids to Navigation (AtoN)  
Brand Name : AMEC  
Model Name : MANDO-301; MANDO-302; MANDO-303  
Applicant : Alltek Marine Electronics Corp.  
Date of Test : Jun. 14, 2011 ~ Jun. 20, 2011  
Standards : EN 300 440-1 V1.6.1 (2010-08)  
              EN 300 440-2 V1.4.1 (2010-08)

The above equipment has been tested and found compliance with the requirement of the relative standards by Neutron Engineering Inc. EMC Laboratory.

The test data, data evaluation, and equipment configuration contained in our test report (Ref No. NEI-ETSP-1-R1105011) were obtained utilizing the test procedures, test instruments, test sites that has been accredited by the Authority of NVLAP and TAF according to the ISO-17025 quality assessment standard and technical standard(s).



**2. RFI EMISSIONS MEASUREMENT**

**2.1 TEST FACILITY**

The test facilities used to collect the test data in this report:

**CB07:** 1F., No. 61, Ln. 77, Sing-ai Rd., Neihu Dist., Taipei City 114, Taiwan (R.O.C.)

**2.2 MEASUREMENT UNCERTAINTY**

Measurement Uncertainty for a Level of Confidence of 95 %,  $U=2xUc(y)$ .

The measurement instrumentation uncertainty considerations contained in CISPR 16-4-2.

Parameters	Uncertainty
Radio frequency	$\pm 1 \times 10^{-7}$
RF power (conducted)	$\pm 2,5$ dB
Radiated emission of transmitter, valid to 26,5 GHz	$\pm 6$ dB
Radiated emission of receiver, valid to 26,5 GHz	$\pm 6$ dB
Temperature	$\pm 1^\circ$ C
Humidity	$\pm 5$ %
Voltage (DC)	$\pm 1$ %
Voltage (AC, < 10 kHz)	$\pm 2$ %

Our calculated Measurement Instrumentation Uncertainty is shown in the tables above. These are our  $U_{lab}$  values in CISPR 16-4-2 terminology.

Since Table 1 of CISPR 16-4-2 has values of measurement instrumentation uncertainty, called  $U_{CISPR}$ , as follows:

Conducted Disturbance (mains port) – 150 kHz – 30 MHz : 3.6 dB

Radiated Disturbance (electric field strength on an open area test site or alternative test site) – 30 MHz – 1000 MHz : 5.2 dB

It can be seen that our  $U_{lab}$  values are smaller than  $U_{CISPR}$ .

**2.3 TEST CONDITIONS AND CHANNEL**

	Normal Test Conditions	Extreme Test Conditions
Temperature	25°C - 35°C	-20°C ~ 60°C
Relative Humidity	20% - 75%	N/A
Supply Voltage	DC 12V	DC 10.8 ~ 13.2V

AIS Aids to Navigation (AtoN)		
Test Channel	EUT Channel	Test Frequency (MHz)
---	CH1	1575.42MHz



**NOTE:**

- (1) For tests at extreme temperatures, measurements shall be made in accordance with the procedures specified in clause 5.4.1.2(EN 300 440 -1), at the upper and lower temperatures of the range as follows:

Category I (General):	-20°C to +55°C
Category II (Portable equipment):	-10°C to +55°C
Category III (Equipment for normal indoor use):	+5°C to +35°C

- (2) Mains voltage:

The extreme test voltage for equipment to be connected to an AC mains source shall be the nominal mains voltage  $\pm 10\%$ .

Regulated lead-acid or gel-cell type batteries:

When the radio equipment is intended for operation from the usual type of regulated lead-acid battery power sources, the extreme test voltages shall be 1,3 and 0,9 multiplied by the nominal voltage of the battery (6 V, 12 V, etc.).

For float charge applications using "gel-cell" type batteries, the extreme test voltages shall be 1,15 and 0,85 multiplied by the nominal voltage of the declared battery voltage.

Power sources using other types of batteries:

The lower extreme test voltages for equipment with power sources using the following types of battery shall be:

- for the Leclanché or lithium type battery: 0,85 times the nominal voltage of the battery;
- for the nickel-cadmium type of battery: 0,9 times the nominal voltage of the battery. In both cases, the upper extreme test voltage shall be 1,15 times the nominal voltage of the battery.
- for other types of batteries, the lower extreme test voltage for the discharged condition shall be declared by the equipment provider.

The nominal voltage is considered to be the upper extreme test voltage in this case.

- (3) The measurements are performed at the highest, middle, lowest available channels.



**2.4 TEST METHODOLOGY AND RESULTS**

ETSI EN 300 440-2 V1.4.1							
Technical Essential Requirement			Technical Requirement Conditionality		Test Specification		
No	Description	Reference: Clause No	U/C	Condition	E/O	Reference: Clause No	Observations
1	Equivalent isotropically radiated power	4.2.1.1	U		E	5.3.1	N/A
2	Permitted range of operating frequencies	4.2.1.2	U		E	5.3.2	N/A
3	Unwanted emissions in the spurious domain	4.2.1.3	U		E	5.3.3	N/A
4	Duty cycle	4.2.1.4	C	Does apply for RFID in 2 446 MHz to 2 454 MHz only	O		N/A
5	Adjacent channel selectivity	4.2.2.1	C	Applies to Category 1 receivers only. Does not apply to GBSAR (see note)	E	5.4.1	N/A
6	Blocking or desensitization	4.2.2.2	C	Applies to Category 1 and Category 2 receivers. Does not apply to GBSAR (see note)	E	5.4.2	N/A
7	Spurious radiations	4.2.2.3	U		E	5.4.3	PASS
8	2,45 GHz RFID systems	4.2.3	C	Applies to 2,45 GHz RFID systems only	E	5.5	N/A
9	Effective radiated power	4.2.4.1	C	Applies to GBSAR systems only	E	5.6.1	N/A
10	Permitted range of operating frequencies	4.2.4.2	C	Applies to GBSAR only	E	5.6.2	N/A
11	DAA threshold	4.2.4.3	C	Applies to GBSAR only	E	5.6.3	N/A
12	Minimum listen time	4.2.4.3.1.1	C	Applies to GBSAR only	E	5.6.4.1	N/A
13	Minimum listen time after detection	4.2.4.3.1.2	C	Applies to GBSAR only	E	5.6.4.2	N/A
14	Maximum transmit on-time	4.2.4.3.1.3	C	Applies to GBSAR only	E	5.6.4.3	N/A
15	Minimum transmit off-time	4.2.4.3.1.4	C	Applies to GBSAR only	E	5.6.4.4	N/A
16	Antenna pattern	4.2.4.4	C	Applies to GBSAR only	E	5.6.5	N/A
17	Unwanted emissions in the spurious domain	4.2.4.5	C	Applies to GBSAR only	E	5.6.6	N/A

NOTE: GBSAR is radar for which items 9 to 17 apply.



NOTE:

- (1) **"U/C"**: indicates whether the requirement is to be **unconditionally** applicable (**U**) or is **conditional** upon the manufacturers claimed functionality of the equipment (**C**).  
**"E/O"**: indicates whether the test specification forms part of the Essential Radio Test Suite (**E**) or whether it is one of the Other Test Suite (**O**).  
**"X"**: indicates there is no test specified corresponding to the requirement.  
**"N/A"**: indicates test is not applicable in this Test Report.
- (2) **Adaptive Frequency Agility (AFA):**  
The capability of an equipment to dynamically change channel within its available frequencies for proper operation.  
**listen before talk (LBT):**  
Combination of the listen mode followed by the talk mode provider: means the manufacturer, or his authorized representative or the person responsible for placing on the market.
- (3) The emission of the transmitter on standby mode is equal to that of receiving mode.





**3. GENERAL INFORMATION**

**3.1 GENERAL DESCRIPTION OF EUT**

Equipment	AIS Aids to Navigation (AtoN)		
Brand Name	AMEC		
Model Name	MANDO-301; MANDO-302; MANDO-303		
OEM Brand/Model Name	N/A		
Model Difference	All models are based on similar electrical circuit except the difference of list below:		
	Model Name	Transmitter(s)	Receiver(s)
	MANDO-301	1	0
	MANDO-302	1	1
	MANDO-303	1	2
	All the above models were tested, and the model: MANDO-301 was found to be the worst case during the pre-scanning test. This model of the worst case was used for final testing and collecting test data included in this report.		
Product Description	The EUT is an AIS Aids to Navigation (AtoN).		
	Operation Frequency:	1575.42 MHz	
	Product Class:	Class 1	
	Receiver Class:	Class 3	
	Modulation Type:	Phase	
	Number Of Channel	1 Channels CH1: 1575.42 MHz	
	Antenna Designation:	Please refer to the Note 2.	
	Antenna Gain(Peak)	Please refer to the Note 2.	
	Based on the application, features, or specification exhibited in User's Manual, the EUT is considered as an ITE/Computing Device. More details of EUT technical specification, please refer to the User's Manual.		
Power Source	DC Voltage supplied from DC Source.		
Power Rating	DC 12V		
Connecting I/O Port(s)	Please refer to the User's Manual		
Products Covered	N/A		
EUT Modification(s)	N/A		
Hardware	M-PCB-CTLNC3, M-PCB-RFNR2		
Software	Version: 1.4.3		

Note:

1. For a more detailed features description, please refer to the manufacturer's specifications or the User's Manual.
2. Table of Filed Antenna:

Antenn	Brand	Model Name	Type	Connector Type	Gain (dBi)
1	AMEC	ALT06-310510	Dipole	Type M	2.86



### 3.2 DESCRIPTION OF TEST MODES

To investigate the maximum EMI emission characteristics generates from EUT, the test system was pre-scanning tested base on the consideration of following EUT operation mode or test configuration mode which possible have effect on EMI emission level. Each of these EUT operation mode(s) or test configuration mode(s) mentioned above was evaluated respectively.

Test Items	Mode	Data Rate	Channel	Note
Spurious radiations (30MHz~1GHz)	GMSK	500K	----	
Spurious radiations (1GHz~12.75GHz)	GMSK	500K	----	

### 3.3 BLOCK DIAGRAM SHOWING THE CONFIGURATION OF SYSTEM TESTED

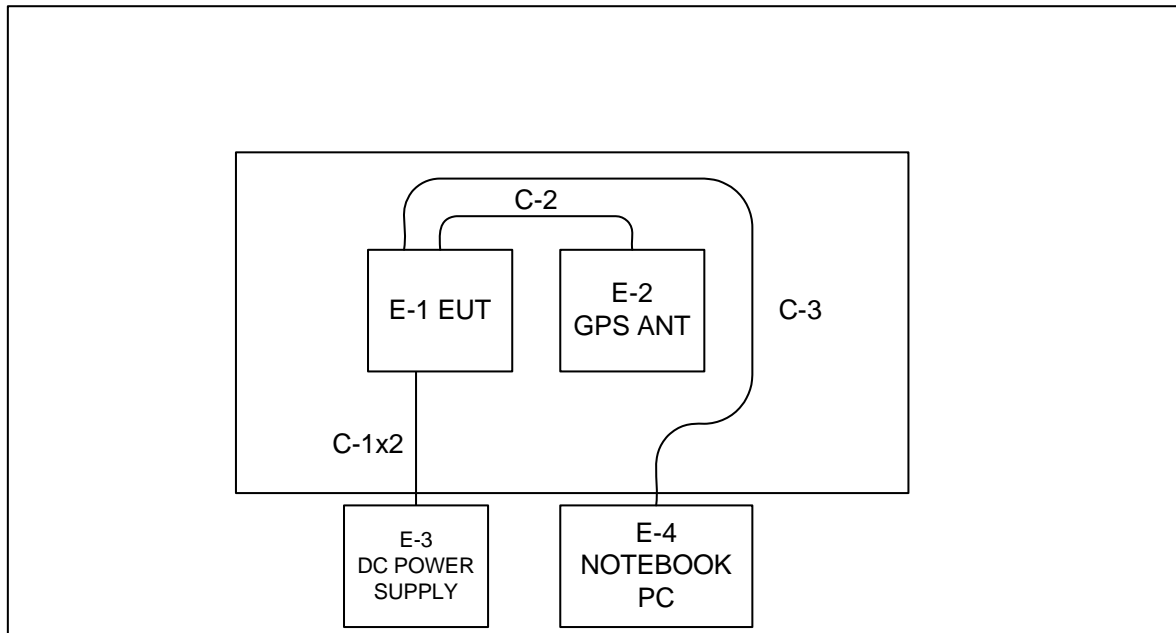

C-1 Power Cable  
C-2 SIGNAL CABLE  
C-3 RS232 CABLE



**3.4 DESCRIPTION OF SUPPORT UNITS**

The EUT has been tested as an independent unit together with other necessary accessories or support units. The following support units or accessories were used to form a representative test configuration during the tests.

Item	Equipment	Mfr/Brand	Model/Type No.	FCC ID	Series No.	Note
E-1	AIS Aids to Navigation (AtoN)	AMEC	MANDO-301	N/A	N/A	EUT
E-2	ANT	AMEC	N/A	N/A	N/A	
E-3	DC Power Supply	GOOD WILL	GPC-3030D	N/A	B710591	
E-4	Notebook PC	DELL	D600	DOC	7T390 A03	

Item	Shielded Type	Ferrite Core	Length	Note
C-1	NO	NO	1.5m	POWER CABLE
C-2	YES	NO	8.0m	SIGNAL CABLE
C-3	YES	NO	1.2m	RS232 CABLE

Note:

- (1) For detachable type I/O cable should be specified the length in cm in 『Length』 column.

**3.5 EUT OPERATING CONDITIONS**

The EUT was configured for testing in a typical fashion (as a customer would normally use it). The EUT has been programmed to continuously transmit during test. This operating condition was tested and used to collect the included data.



**4. SPURIOUS EMISSIONS – RECEIVER (30 - 1000MHz)**

**4.1 APPLIED PROCEDURES / LIMIT**

Test Item	Frequency(MHz)	Limit
Spurious emissions	25-1000	-57dBm
(radiated)	1000-12750	-47dBm

**4.1.1 MEASUREMENT INSTRUMENTS LIST**

Item	Kind of Equipment	Manufacturer	Type No.	Serial No.	Calibrated until
1	Spectrum Analyzer	R&S	FSP-30	100854	Aug. 19, 2011
2	Microwave Pre_amplifier	Agilent	8449B	3008A02331	Jan. 16, 2012
3	Horn Antenna	EMCO	3115	60117	Aug. 26, 2011
4	Microflex Cable	NA	NA	1m	Sep. 07 , 2011
5	Microflex Cable	AISI	S104-SMAP-1	10m	Aug. 22, 2011

Remark: " N/A" denotes No Model Name, Serial No. or No Calibration specified.

**4.1.2 MEASURING INSTRUMENTS AND SETTING**

Spectrum Analyzer	Setting
Start Frequency	25 MHz
Stop Frequency	10th carrier frequency
Detector	Positive Peak
Sweep Time	Auto
RBW / VBW	(Below 1GHz) 100 kHz / 100 kHz ; (Above 1GHz) 1 MHz / 1 MHz



#### **4.1.3 TEST PROCEDURE**

- a. The EUT was placed on the top of the turntable in open test site area.
- b. The test shall be made in the transmitting mode. The turntable was rotated by 360 degrees to determine the position of the highest radiation.
- c. For 30~1000MHz spurious emissions measurement, the broad band bi-log receiving antenna was placed 3 meters far away from the turntable. .
- d. The broadband receiving antenna was fixed on the same height with the EUT to find each suspected emissions of both horizontal and vertical polarization. Each recorded suspected value is indicated as Read Level (Raw).
- e. Replace the EUT by standard antenna and feed the RF port by signal generator.
- f. Adjust the frequency of the signal generator to the suspected emission and slightly rotate the turntable to locate the position with maximum reading.
- g. Adjust the power level of the signal generator to reach the same reading with Read Level (Raw).
- h. The level of the spurious emission is the power level of (g) plus the gain of the standard antenna in dBi and minus the loss of the cable used between the signal generator and the standard antenna.
- i. The measurement shall be repeated at the lowest and the highest channel of the stated frequency range.

#### **4.1.4 DEVIATION FROM TEST STANDARD**

No deviation.

#### **4.1.5 TEST SETUP LAYOUT**

This test setup layout is the same as that shown in section 6.1.4

#### **4.1.6 EUT OPERATING CONDITIONS**

The EUT was programmed to be in continuously transmitting mode.

#### **4.1.7 RESULTS OF STANDBY MODE SPURIOUS EMISSIONS**

The emission of the transmitter on standby mode is equal to that of receiving mode.



**4.1.8 TEST RESULTS**

E.U.T :	AIS Aids to Navigation (AtoN)	Model Name :	MANDO-301
Temperature :	25 °C	Relative Humidity :	36%
Test Voltage :	DC 12V		
Test Mode :	RX		

Freq. (MHz)	Polarization H/V	EUT Axis X/Y/Z	TX/RX	Reading Level (dBuV)	Correct Factor(dB)	Measurement (dBuV/m)	Limit(Quasi-Peak) (dBuV/m)	Margin (dB)	Note
47.4599	V	X	RX	-65.75	4.58	-61.17	-57.00	- 4.17	(QP)
220.1199	V	X	RX	-61.35	-1.35	-62.70	-57.00	- 5.70	
336.5199	V	X	RX	-59.50	0.08	-59.42	-57.00	- 2.42	
377.2600	V	X	RX	-58.57	-0.55	-59.12	-57.00	- 2.12	
499.4800	V	X	RX	-62.54	0.46	-62.08	-57.00	- 5.08	
590.6599	V	X	RX	-66.71	2.65	-64.06	-57.00	- 7.06	
53.2799	H	X	RX	-61.76	-0.06	-61.82	-57.00	- 4.82	
154.1600	H	X	RX	-68.27	6.60	-61.67	-57.00	- 4.67	
299.6600	H	X	RX	-58.67	-0.92	-59.59	-57.00	- 2.59	
336.5199	H	X	RX	-59.20	0.01	-59.19	-57.00	- 2.19	
365.6199	H	X	RX	-59.72	0.32	-59.40	-57.00	- 2.40	
385.0199	H	X	RX	-62.17	0.32	-61.85	-57.00	- 4.85	

**Note:**

- (1) EUT Orthogonal Axis:  
 "X" - denotes Laid on Table; "Y" - denotes Vertical Stand; "Z" - denotes Side Stand.
- (2) Data of measurement within this frequency range shown "\*" in the table above means the reading of emissions are attenuated more than 20dB below the permissible limits or the field strength is too small to be measured.



### Vertical

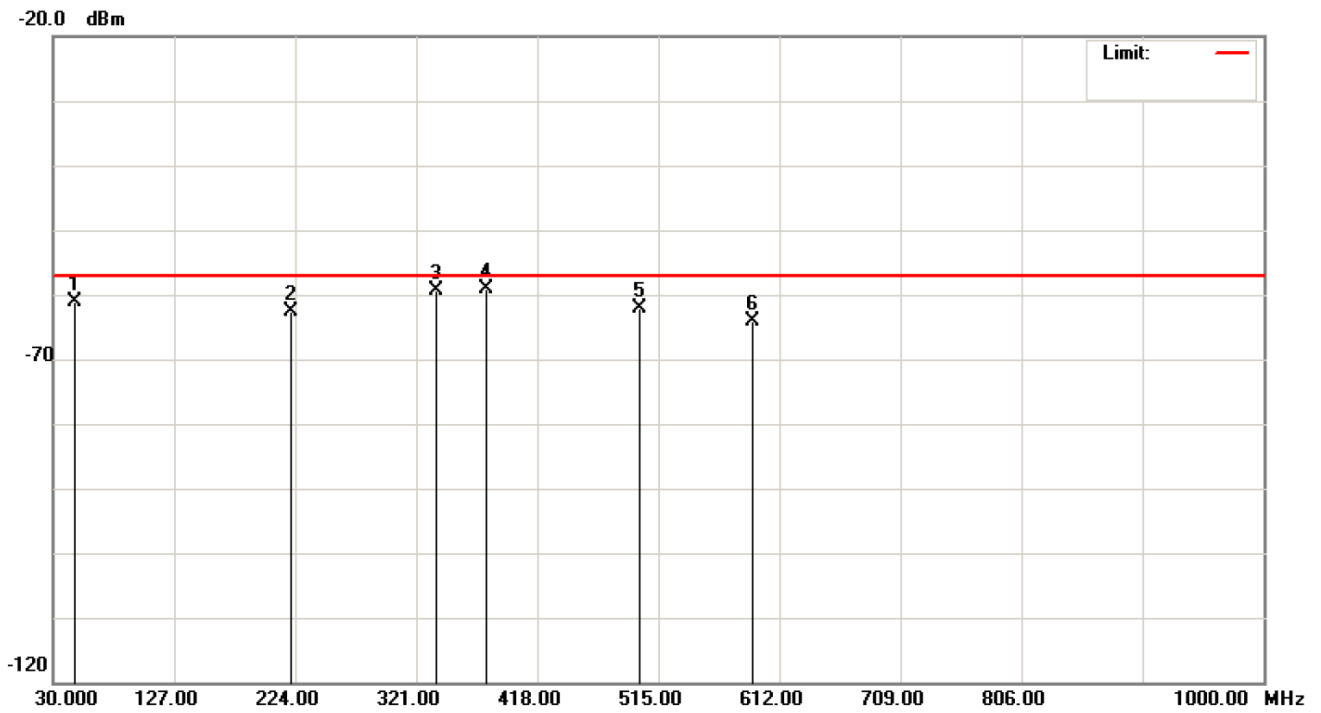

### Horizontal

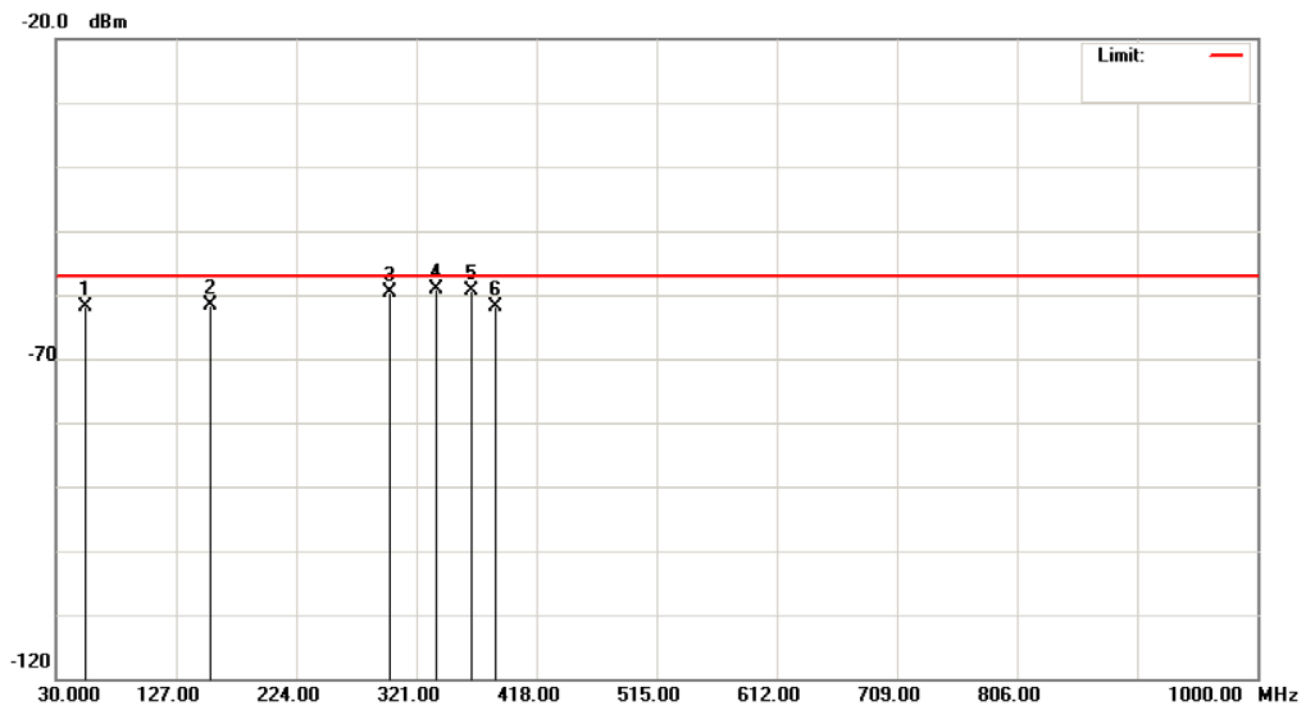





**5. SPURIOUS EMISSIONS – RECEIVER (ABOVE 1000MHz)**

**5.1 APPLIED PROCEDURES / LIMIT**

Test Item	Frequency(MHz)	Limit
Spurious emissions	25-1000	-57dBm
(narrowband)	1000-12750	-47dBm

**5.1.1 MEASUREMENT INSTRUMENTS LIST**

Item	Kind of Equipment	Manufacturer	Type No.	Serial No.	Calibrated until
1	Spectrum Analyzer	R&S	FSP-30	100854	Aug. 19, 2011
2	Microwave Pre_amplifier	Agilent	8449B	3008A02331	Jan. 16, 2012
3	Horn Antenna	EMCO	3115	60117	Aug. 26, 2011
4	Microflex Cable	NA	NA	1m	Sep. 07 , 2011
5	Microflex Cable	AISI	S104-SMAP-1	10m	Aug. 22, 2011

Remark: " N/A" denotes No Model Name, Serial No. or No Calibration specified.

**5.1.2 MEASURING INSTRUMENTS AND SETTING**

Spectrum Analyzer	Setting
Start Frequency	25 MHz
Stop Frequency	10th carrier frequency
Detector	Positive Peak
Sweep Time	Auto
RBW / VBW	(Below 1GHz) 100 kHz / 100 kHz ; (Above 1GHz) 1 MHz / 1 MHz



### **5.1.3 TEST PROCEDURE**

- a. The EUT was placed on the top of the turntable in open test site area.
- b. The test shall be made in the transmitting mode. The turntable was rotated by 360 degrees to determine the position of the highest radiation.
- c. For 30~1000MHz spurious emissions measurement, the broad band bi-log receiving antenna was placed 3 meters far away from the turntable. .
- d. The broadband receiving antenna was fixed on the same height with the EUT to find each suspected emissions of both horizontal and vertical polarization. Each recorded suspected value is indicated as Read Level (Raw).
- e. Replace the EUT by standard antenna and feed the RF port by signal generator.
- f. Adjust the frequency of the signal generator to the suspected emission and slightly rotate the turntable to locate the position with maximum reading.
- g. Adjust the power level of the signal generator to reach the same reading with Read Level (Raw).
- h. The level of the spurious emission is the power level of (g) plus the gain of the standard antenna in dBi and minus the loss of the cable used between the signal generator and the standard antenna.
- i. The measurement shall be repeated at the lowest and the highest channel of the stated frequency range.

### **5.1.4 DEVIATION FROM TEST STANDARD**

No deviation.

### **5.1.5 TEST SETUP LAYOUT**

This test setup layout is the same as that shown in section 7.1.4

### **5.1.6 EUT OPERATING CONDITIONS**

The EUT was programmed to be in continuously transmitting mode.

### **5.1.7 RESULTS OF STANDBY MODE SPURIOUS EMISSIONS**

The emission of the transmitter on standby mode is equal to that of receiving mode.



**5.1.8 TEST RESULTS**

E.U.T :	AIS Aids to Navigation (AtoN)	Model Name :	MANDO-301
Temperature :	25 ° C	Relative Humidity :	36%
Test Voltage :	DC 12V		
Test Mode :	RX		

Freq. (MHz)	Polarization H/V	EUT Axis X/Y/Z	TX/RX	Reading Level (dBuV)	Correct Factor(dB)	Measurement (dBuV/m)	Limit(Quasi-Peak) (dBuV/m)	Margin (dB)	Note
1330.000	V	X	RX	-50.76	-1.91	-52.67	-47.00	- 5.67	
1330.000	H	X	RX	-59.09	-2.02	-61.11	-47.00	- 14.11	

- (1) EUT Orthogonal Axis:  
 "X" - denotes Laid on Table; "Y" - denotes Vertical Stand; "Z" - denotes Side Stand.
- (2) Data of measurement within this frequency range shown "\*" in the table above means the reading of emissions are attenuated more than 20dB below the permissible limits or the field strength is too small to be measured.



### Vertical

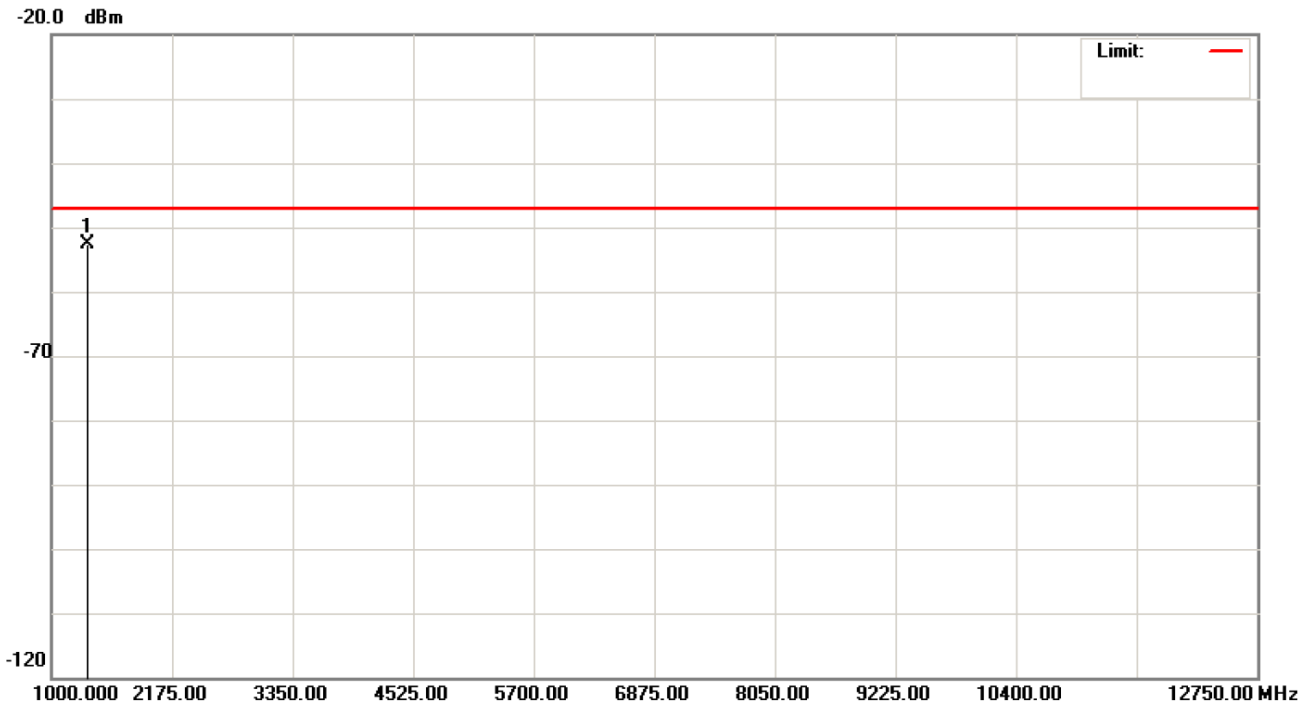

### Horizontal

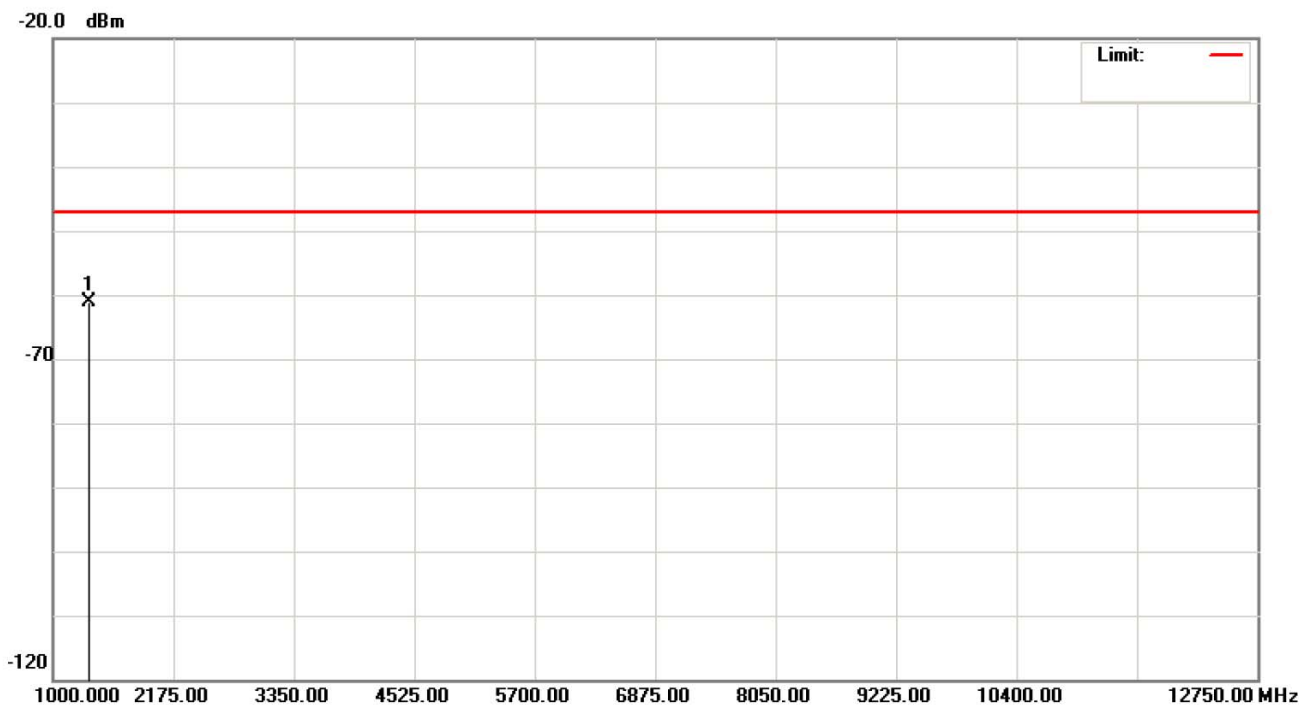

**6. EUT TEST PHOTO**

**Radiated Measurement Photos**

