

FCC Test Report

Product Name	AIS Class B Transponder
Model No.	CAMINO-108W
FCC ID.	WZ7AIS-B108 Contains FCC ID: WZ7AIS-W

Applicant	Alltek Marine Electronics Corp.
Address	7F, No.605, Ruei Guang Rd., Neihu, Taipei, Taiwan, 114 R.O.C.

Date of Receipt	May 06, 2013
Issue Date	Dec. 26, 2013
Report No.	135096R-RFUSP42V01
Report Version	V2.0



The test results relate only to the samples tested.
The test report shall not be reproduced except in full without the written approval of Quietek Corporation.
This report must not be used to claim product endorsement by TAF or any agency of the U.S. Government.

Test Report Certification

Issue Date: Dec. 26, 2013

Report No.: 135096R-RFUSP42V01



Product Name	AIS Class B Transponder
Applicant	Alltek Marine Electronics Corp.
Address	7F, No.605, Ruei Guang Rd., Neihu, Taipei, Taiwan, 114 R.O.C.
Manufacturer	Alltek Marine Electronics Corp.
Model No.	CAMINO-108W
FCC ID.	WZ7AIS-B108 Contains FCC ID: WZ7AIS-W
EUT Rated Voltage	DC 9.6~31.2V
EUT Test Voltage	DC 12V/24V
Trade Name	AMEC
Applicable Standard	FCC CFR Title 47 Part 15 Subpart C: 2012 ANSI C63.4: 2003, ANSI C63.10: 2009, KDB 558074
Test Result	Complied

The test results relate only to the samples tested.

The test report shall not be reproduced except in full without the written approval of Quietek Corporation.

This report must not be used to claim product endorsement by TAF or any agency of the U.S. Government.

Documented By :

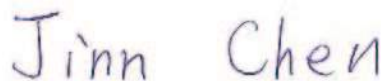

(Senior Adm. Specialist / Jinn Chen)

Tested By :



(Engineer / Alan Chen)

Approved By :



(Director / Vincent Lin)

TABLE OF CONTENTS

Description	Page
1. GENERAL INFORMATION	6
1.1. EUT Description.....	6
1.2. Operational Description	8
1.3. Tested System Details.....	9
1.4. EUT Test Setup Environment & Configuration of AIS System	9
1.5. EUT Operation Procedures.....	10
1.6. Test Facility	11
2. Conducted Emission.....	12
2.1. Test Equipment.....	12
2.2. Test Setup	12
2.3. Limits	13
2.4. Test Procedure	13
2.5. Uncertainty	13
2.6. Test Result of Conducted Emission.....	14
3. Peak Power Output	16
3.1. Test Equipment.....	16
3.2. Test Setup	16
3.3. Limits	16
3.4. Test Procedure	16
3.5. Uncertainty	16
3.6. Test Result of Peak Power Output.....	17
4. Radiated Emission.....	20
4.1. Test Equipment.....	20
4.2. Test Setup	20
4.3. Limits	21
4.4. Test Procedure	22
4.5. Uncertainty	22
4.6. Test Result of Radiated Emission.....	23
5. RF antenna conducted test.....	35
5.1. Test Equipment.....	35
5.2. Test Setup	35
5.3. Limits	35
5.4. Test Procedure	35
5.5. Uncertainty	36
5.6. Test Result of RF antenna conducted test.....	37
6. Band Edge	43
6.1. Test Equipment.....	43
6.2. Test Setup	43
6.3. Limits	44
6.4. Test Procedure	44
6.5. Uncertainty	44
6.6. Test Result of Band Edge	45

7.	Occupied Bandwidth	57
7.1.	Test Equipment.....	57
7.2.	Test Setup	57
7.3.	Limits	57
7.4.	Test Procedure	57
7.5.	Uncertainty	57
7.6.	Test Result of Occupied Bandwidth	58
8.	Power Density	67
8.1.	Test Equipment.....	67
8.2.	Test Setup	67
8.3.	Limits	67
8.4.	Test Procedure	67
8.5.	Uncertainty	67
8.6.	Test Result of Power Density	68
9.	EMI Reduction Method During Compliance Testing	77

Attachment 1: EUT Test Setup Photographs

Revision History

Rev.	Issue Date	Revisions	Effect page
V1.0	Nov. 04, 2013	Initial Issue	All
V2.0	Dec. 26, 2013	1. Modify Model Number 2. Modify FCC ID. add "Contains FCC ID: WZ7AIS-W" 3. Delete Attachment 2: EUT Detailed Photographs 4. Modify P. 45-56 Band Edge data	1,2,6,45-56,79

1. GENERAL INFORMATION

1.1. EUT Description

Product Name	AIS Class B Transponder
Trade Name	AMEC
Model No.	CAMINO-108W
FCC ID.	WZ7AIS-B108 Contains FCC ID: WZ7AIS-W
Frequency Range	2412-2462MHz for 802.11b/g/n-20BW
Number of Channels	802.11b/g/n-20MHz: 11
Data Speed	802.11b: 1-11Mbps, 802.11g: 6-54Mbps, 802.11n: up to 72.2Mbps
Type of Modulation	802.11b:DSSS, DBPSK, DQPSK, CCK 802.11g/n:OFDM, BPSK, QPSK, 16QAM, 64QAM
Antenna Type	Dipole
Antenna Gain	Refer to the table "Antenna List"
Channel Control	Auto
USB Cable	Shielded, 1.8m
NMEA2000 Cable	Shielded, 3m
VHF Cable	Shielded, 10m
GPS Cable	Shielded, 10m
Hardware	M-PCB-B108MBV1
Software	V1.2.6

Antenna List

No.	Manufacturer	Model No.	Antenna Type	Peak Gain
1	Alltek Marine Electronics Corp.	M-ANT-SAA04-05005G-01	Dipole	2 dBi for 2.4 GHz

Note: The antenna of EUT is conform to FCC 15.203.

802.11b/g/n-20MHz Center Frequency of Each Channel:

Channel	Frequency	Channel	Frequency	Channel	Frequency	Channel	Frequency
Channel 01:	2412 MHz	Channel 02:	2417 MHz	Channel 03:	2422 MHz	Channel 04:	2427 MHz
Channel 05:	2432 MHz	Channel 06:	2437 MHz	Channel 07:	2442 MHz	Channel 08:	2447 MHz
Channel 09:	2452 MHz	Channel 10:	2457 MHz	Channel 11:	2462 MHz		

Note:

1. The EUT is an AIS Class B Transponder with a built-in 2.4GHz WLAN transceiver.
2. Regarding to the operation frequency, the lowest, middle and highest frequency are selected to perform the test.
3. Lowest and highest data rates are tested in each mode. Only worst case is shown in the report. (802.11b is 1Mbps 、 802.11g is 6Mbps 、 802.11n(20M-BW) is 7.2Mbps .
4. These tests are conducted on a sample for the purpose of demonstrating compliance of 802.11b/g/n transmitter with Part 15 Subpart C Paragraph 15.247 of spread spectrum devices.

Test Mode:	Mode 1: Transmit (802.11b 1Mbps)
	Mode 2: Transmit (802.11g 6Mbps)
	Mode 3: Transmit (802.11n MCS0 7.2Mbps 20M-BW)

1.2. Operational Description

The EUT is an AIS Class B Transponder, This device provided four kinds of transmitting speed 1, 2, 5.5 and 11Mbps and the device of RF carrier is DBPSK, DQPSK and CCK (IEEE 802.11b). The device provided of eight kinds of transmitting speed 6, 9, 12, 18, 24, 36, 48 and 54Mbps the device of RF carrier is BPSK, QPSK, 16QAM and 64QAM (IEEE 802.11g).

The device provided of eight kinds of transmitting speed 7.2,14.4,21.7,28.9,43.3,57.8,65 and 72.2Mbps in 802.11n(20M-BW) mode, The IEEE 802.11n is Single In, Single Out” (SISO) technology and one antennas to support 1(Transmit) * 1(Receive) SISO technology.

This AIS Class B Transponder, compliant with IEEE 802.11b/g/n, is a high-efficiency Wireless LAN adapter. It allows your computer to connect to a wireless network and to share resources, such as files or printers without being bound to the network wires. Operation in 2.4GHz Direct Sequence Spread Spectrum (DSSS) and Orthogonal Frequency Division Multiplexing (OFDM) radio transmission, the AIS Class B Transponder Wired Equivalent Protection (WEP) algorithm is used. In addition, its standard compliance ensures that it can communicate with any IEEE 802.11b/g/n network.

This device does not support 802.11n(40M-BW) technology.

1.3. Tested System Details

The types for all equipment, plus descriptions of all cables used in the tested system (including SD cards) are:

	Product	Manufacturer	Model No.	Serial No.	Power Cord
1	DC Power Supply	GWINSTEK	SPD-3606	N/A	Non-Shielded, 1.8m
2	Notebook PC	DELL	PPT	N/A	Non-Shielded, 0.8m

Signal Cable Type	Signal cable Description
A	USB Cable Shielded, 1.8m
B	NMEA2000 Cable Shielded, 3m
C	Power/Data Cable Shielded, 1.4m
D	RS232 Cable Shielded, 1.2m
E	VHF Cable Shielded, 10m
F	GPS Cable Shielded, 10m

1.4. EUT Test Setup Environment & Configuration of AIS System

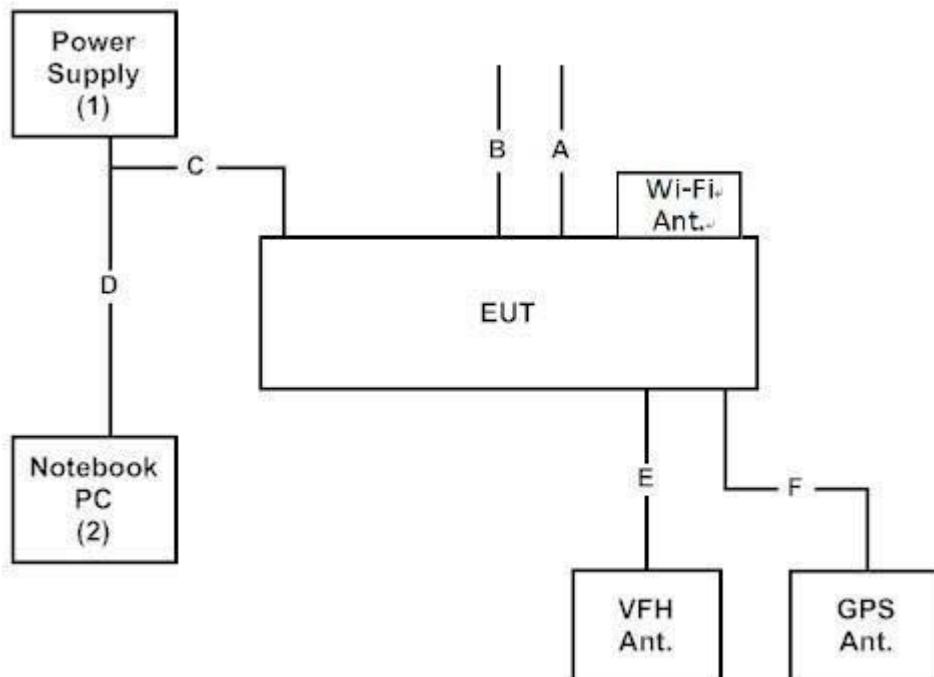

1.5. EUT Operation Procedures

- (1) Setup the EUT as shown in Section 1.4
- (2) Execute program “WL.exe ” on the Notebook PC.
- (3) Configure the test mode, the test channel, and the data rate.
- (4) Press “OK” to start the continuous Transmit.
- (5) Verify that the EUT works properly.

1.6. Test Facility

Ambient conditions in the laboratory:

Items	Required (IEC 68-1)	Actual
Temperature (°C)	15-35	20-35
Humidity (%RH)	25-75	50-65
Barometric pressure (mbar)	860-1060	950-1000

The related certificate for our laboratories about the test site and management system can be downloaded from Quietek Corporation's Web Site : <http://tw.quietek.com/modules/myalbum/>

The address and introduction of Quietek Corporation's laboratories can be founded in our Web site : <http://www.quietek.com/>

Site Description: File on
Federal Communications Commission
FCC Engineering Laboratory
7435 Oakland Mills Road
Columbia, MD 21046
Registration Number: 92195

Site Name: Quietek Corporation
Site Address: No.5-22, Ruishukeng Linkou Dist., New Taipei City
24451, Taiwan, R.O.C.

TEL: 886-2-8601-3788 / FAX : 886-2-8601-3789
E-Mail : service@quietek.com

FCC Accreditation Number: TW1014

2. Conducted Emission

2.1. Test Equipment

	Equipment	Manufacturer	Model No. / Serial No.	Last Cal.	Remark
X	Test Receiver	R & S	ESCS 30 / 825442/018	Sep., 2013	
X	Artificial Mains Network	R & S	ENV4200 / 848411/10	Feb., 2013	Peripherals
X	LISN	R & S	ESH3-Z5 / 825562/002	Feb., 2013	EUT
	DC LISN	Schwarzbeck	8226 / 176	Mar, 2013	EUT
X	Pulse Limiter	R & S	ESH3-Z2 / 357.8810.52	Feb., 2013	
	No.1 Shielded Room				

Note:

1. All equipments are calibrated every one year.
2. The test instruments marked by "X" are used to measure the final test results.

2.2. Test Setup

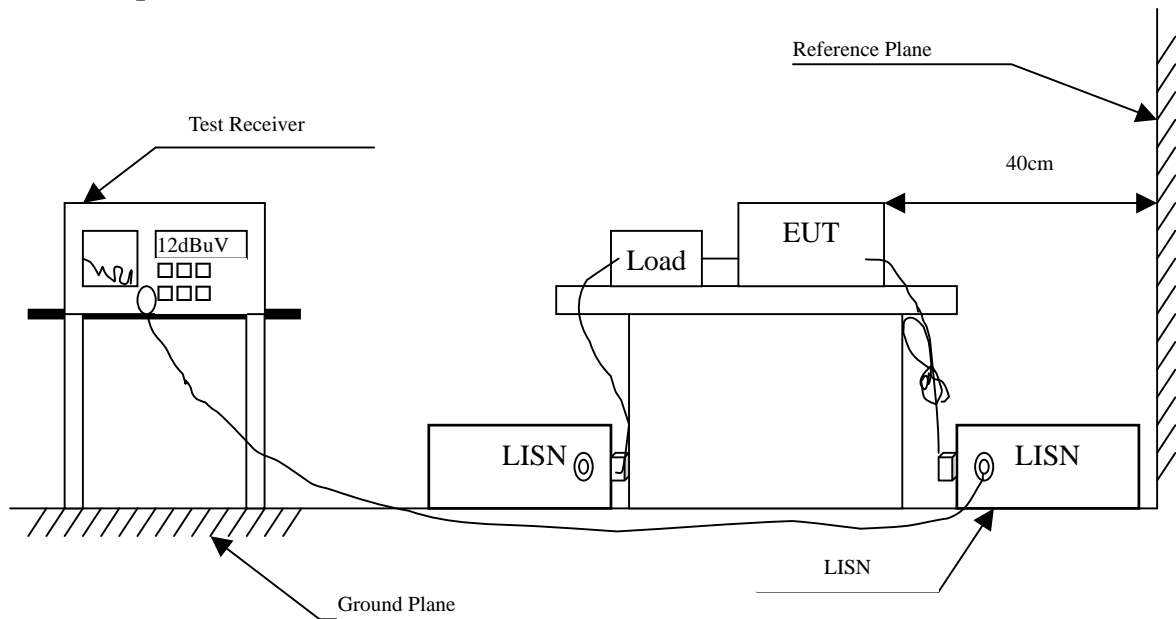

2.3. Limits

FCC Part 15 Subpart C Paragraph 15.207 (dBuV) Limit		
Frequency MHz	Limits	
	QP	AVG
0.15 - 0.50	66-56	56-46
0.50-5.0	56	46
5.0 - 30	60	50

2.4. Test Procedure

The EUT and simulators are connected to the main power through a line impedance stabilization network (L.I.S.N.). This provides a 50 ohm /50uH coupling impedance for the measuring equipment. The peripheral devices are also connected to the main power through a LISN that provides a 50ohm /50uH coupling impedance with 50ohm termination. (Please refers to the block diagram of the test setup and photographs.)

Both sides of D.C. line are checked for maximum conducted interference. In order to find the maximum emission, the relative positions of equipment and all of the interface cables must be changed according to ANSI C63.10: 2009 on conducted measurement.

Conducted emissions were invested over the frequency range from 0.15MHz to 30MHz using a receiver bandwidth of 9kHz.

2.5. Uncertainty

± 2.26 dB

2.6. Test Result of Conducted Emission

Product : AIS Class B Transponder
 Test Item : Conducted Emission Test
 Power Line : Line 1
 Test Mode : Mode 3: Transmit (802.11n MCS0 7.2Mbps 20M-BW) (2437MHz)

Frequency MHz	Correct Factor dB	Reading Level dBuV	Measurement Level dBuV	Margin dB	Limit dBuV
Line 1					
Quasi-Peak					
0.162	9.840	38.430	48.270	-17.387	65.657
0.220	9.840	32.510	42.350	-21.650	64.000
0.252	9.840	27.690	37.530	-25.556	63.086
0.459	9.840	23.570	33.410	-23.761	57.171
1.072	9.850	21.090	30.940	-25.060	56.000
2.357	9.860	15.750	25.610	-30.390	56.000
Average					
0.162	9.840	22.270	32.110	-23.547	55.657
0.220	9.840	23.050	32.890	-21.110	54.000
0.252	9.840	15.460	25.300	-27.786	53.086
0.459	9.840	15.610	25.450	-21.721	47.171
1.072	9.850	20.210	30.060	-15.940	46.000
2.357	9.860	12.670	22.530	-23.470	46.000

Note:

1. All Reading Levels are Quasi-Peak and average value.
2. "■" means the worst emission level.
3. Measurement Level = Reading Level + Correct Factor

Product : AIS Class B Transponder
 Test Item : Conducted Emission Test
 Power Line : Line 2
 Test Mode : Mode 3: Transmit (802.11n MCS0 7.2Mbps 20M-BW) (2437MHz)

Frequency MHz	Correct Factor dB	Reading Level dBuV	Measurement Level dBuV	Margin dB	Limit dBuV
Line 2					
Quasi-Peak					
0.177	9.840	37.460	47.300	-17.929	65.229
0.216	9.840	34.830	44.670	-19.444	64.114
0.392	9.840	26.720	36.560	-22.526	59.086
0.490	9.840	21.490	31.330	-24.956	56.286
1.072	9.840	21.050	30.890	-25.110	56.000
1.502	9.850	18.430	28.280	-27.720	56.000
Average					
0.177	9.840	22.580	32.420	-22.809	55.229
0.216	9.840	27.490	37.330	-16.784	54.114
0.392	9.840	22.570	32.410	-16.676	49.086
0.490	9.840	13.170	23.010	-23.276	46.286
1.072	9.840	19.840	29.680	-16.320	46.000
1.502	9.850	17.490	27.340	-18.660	46.000

Note:

1. All Reading Levels are Quasi-Peak and average value.
2. "■" means the worst emission level.
3. Measurement Level = Reading Level + Correct Factor

3. Peak Power Output

3.1. Test Equipment

	Equipment	Manufacturer	Model No./Serial No.	Last Cal.
X	Power Meter	Anritsu	ML2495A/6K00003357	May, 2013
X	Power Sensor	Anritsu	MA2411B/0738448	Jun, 2013

Note:

1. All equipments are calibrated with traceable calibrations. Each calibration is traceable to the national or international standards.
2. The test instruments marked with “X” are used to measure the final test results.

3.2. Test Setup

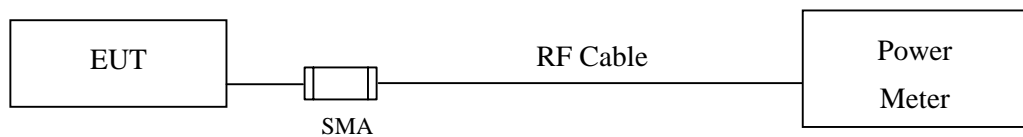

3.3. Limits

The maximum peak power shall be less 1 Watt.

3.4. Test Procedure

The EUT was tested according to DTS test procedure of KDB 558074 for compliance to FCC 47CFR 15.247 requirements. The maximum peak conducted output power using KDB 558074 section 9.1.3 PKPM1 Peak power meter method.

3.5. Uncertainty

± 1.27 dB

3.6. Test Result of Peak Power Output

Product : AIS Class B Transponder
 Test Item : Peak Power Output Data
 Test Site : No.3 OATS
 Test Mode : Mode 1: Transmit (802.11b 1Mbps)

Channel No	Frequency (MHz)	Average Power For different Data Rate (Mbps)				Peak Power	Required Limit	Result
		1	2	5.5	11			
		Measurement Level (dBm)						
01	2412	12.87	--	--	--	15.85	<30dBm	Pass
06	2437	12.08	11.92	11.74	11.66	15.21	<30dBm	Pass
11	2462	11.77	--	--	--	14.11	<30dBm	Pass

Note: Peak Power Output Value = Reading value on power meter + cable loss

Product : AIS Class B Transponder
 Test Item : Peak Power Output Data
 Test Site : No.3 OATS
 Test Mode : Mode 2: Transmit (802.11g 6Mbps)

Channel No	Frequency (MHz)	Average Power For different Data Rate (Mbps)								Peak Power	Required Limit	Result
		6	9	12	18	24	36	48	54	6		
		Measurement Level (dBm)										
01	2412	12.76	--	--	--	--	--	--	--	22.71	<30dBm	Pass
06	2437	12.01	11.89	11.74	11.61	11.49	11.32	11.27	11.21	22.44	<30dBm	Pass
11	2462	11.11	--	--	--	--	--	--	--	21.18	<30dBm	Pass

Note: Peak Power Output Value = Reading value on power meter + cable loss

Product : AIS Class B Transponder
 Test Item : Peak Power Output Data
 Test Site : No.3 OATS
 Test Mode : Mode 3: Transmit (802.11n MCS0 7.2Mbps 20M-BW)

Channel No	Frequency (MHz)	Average Power								Peak Power	Required Limit	Result
		For different Data Rate (Mbps)										
		7.2	14.4	21.7	28.9	43.3	57.8	65	72.2	7.2		
Measurement Level (dBm)												
01	2412	10.75	--	--	--	--	--	--	--	20.89	<30dBm	Pass
06	2437	11.44	11.32	11.21	11.18	11.08	10.99	10.92	10.88	20.64	<30dBm	Pass
11	2462	10.57	--	--	--	--	--	--	--	19.48	<30dBm	Pass

Note: Peak Power Output Value = Reading value on power meter + cable loss

4. Radiated Emission

4.1. Test Equipment

The following test equipment are used during the radiated emission test:

Test Site	Equipment	Manufacturer	Model No./Serial No.	Last Cal.
Site # 3	X Loop Antenna	Teseq	HLA6120 / 26739	Jul., 2013
	X Bilog Antenna	Schaffner Chase	CBL6112B/2673	Sep., 2013
	X Horn Antenna	Schwarzbeck	BBHA9120D/D305	Sep., 2013
	X Horn Antenna	Schwarzbeck	BBHA9170/208	Jul., 2013
	X Pre-Amplifier	Agilent	8447D/2944A09549	Sep., 2013
	X Spectrum Analyzer	Agilent	E4407B / US39440758	May, 2013
	X Test Receiver	R & S	ESCS 30/ 825442/018	Sep., 2013
	X Coaxial Cable	Quietek	QTK-CABLE/ CAB5	Feb., 2013
	X Controller	Quietek	QTK-CONTROLLER/ CTRL3	N/A
	X Coaxial Switch	Anritsu	MP59B/6200265729	N/A

- Note: 1. All equipments are calibrated with traceable calibrations. Each calibration is traceable to the national or international standards.
 2. The test instruments marked with "X" are used to measure the final test results.

4.2. Test Setup

Radiated Emission Below 1GHz

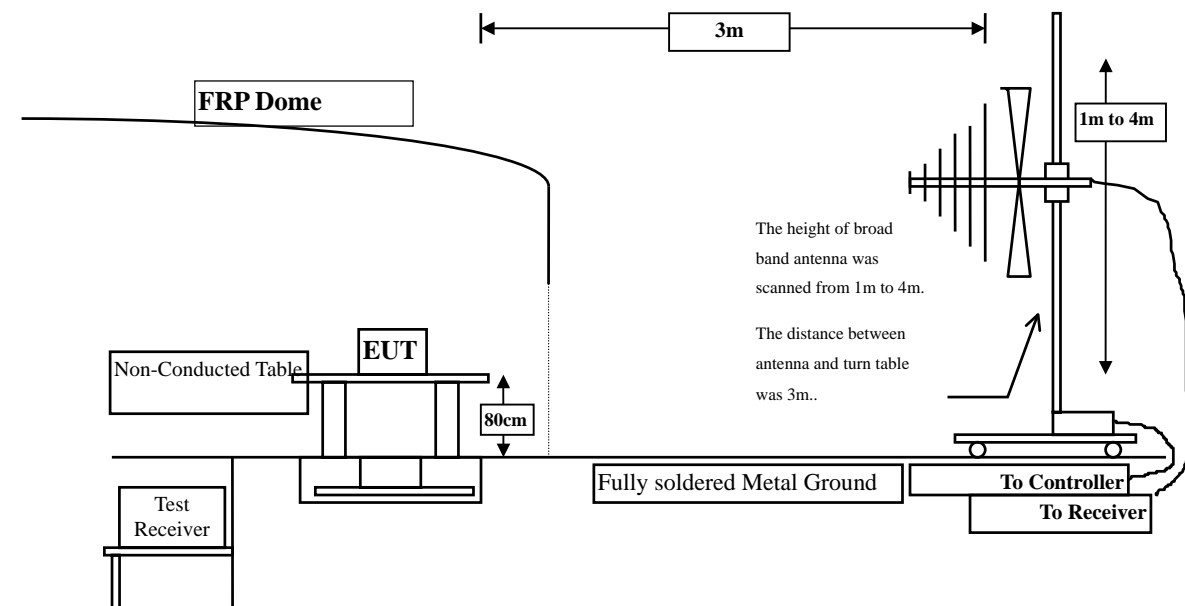

Radiated Emission Above 1GHz

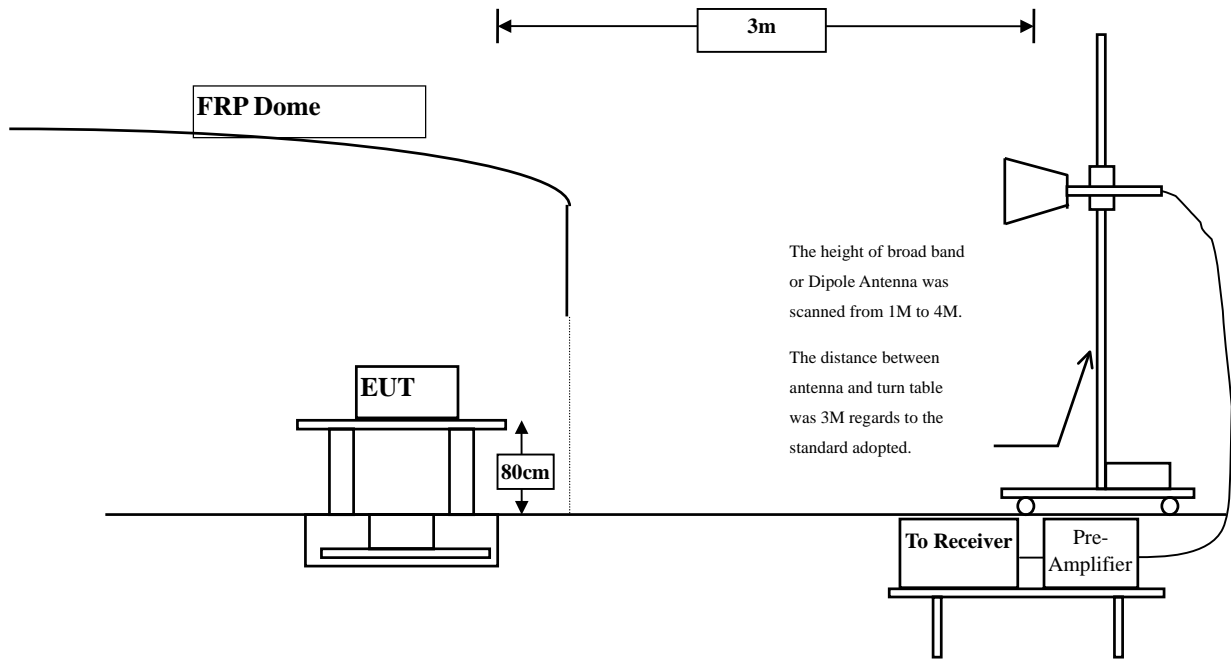

4.3. Limits

Emissions radiated outside of the specified frequency bands, except for harmonics, shall be attenuated by at least 20dB below the level of the fundamental or to the general radiated emission limits in paragraph 15.209, whichever is the lesser attenuation.

FCC Part 15 Subpart C Paragraph 15.209(a) Limits		
Frequency MHz	Field strength (microvolts/meter)	Measurement distance (meter)
0.009-0.490	2400/F(kHz)	300
0.490-1.705	24000/F(kHz)	30
1.705-30	30	30
30-88	100	3
88-216	150	3
216-960	200	3
Above 960	500	3

Remarks: E field strength (dBuV/m) = 20 log E field strength (uV/m)

4.4. Test Procedure

The EUT was setup according to ANSI C63.10: 2009 and tested according to DTS test procedure of KDB 558074 for compliance to FCC 47CFR 15.247 requirements.

The EUT is placed on a turn table which is 0.8 meter above ground. The turn table is rotated 360 degrees to determine the position of the maximum emission level. The EUT was positioned such that the distance from antenna to the EUT was 3 meters.

The antenna is scanned between 1 meter and 4 meters to find out the maximum emission level. This is repeated for both horizontal and vertical polarization of the antenna. In order to find the maximum emission, all of the interface cables were manipulated according to ANSI C63.10: 2009 on radiated measurement.

The resolution bandwidth below 30MHz setting on the field strength meter is 9kHz and 30MHz~1GHz is 120kHz and above 1GHz is 1MHz.

Radiated emission measurements below 30MHz are made using Loop Antenna and 30MHz~1GHz are made using broadband Bilog antenna and above 1GHz are made using Horn Antennas.

The measurement is divided into the Preliminary Measurement and the Final Measurement.

The suspected frequencies are searched for in Preliminary Measurement with the measurement antenna kept pointed at the source of the emission both in azimuth and elevation, with the polarization of the antenna oriented for maximum response. The antenna is pointed at an angle towards the source of the emission, and the EUT is rotated in both height and polarization to maximize the measured emission. The emission is kept within the illumination area of the 3 dB bandwidth of the antenna.

The worst radiated emission is measured in the Open Area Test Site on the Final Measurement.

The frequency range from 9kHz to 10th harmonics is checked.

4.5. Uncertainty

± 3.9 dB above 1GHz

± 3.8 dB below 1GHz

4.6. Test Result of Radiated Emission

Product : AIS Class B Transponder
 Test Item : Harmonic Radiated Emission Data
 Test Site : No.3 OATS
 Test Mode : Mode 1: Transmit (802.11b 1Mbps) (2412MHz)

Frequency MHz	Correct Factor dB	Reading Level dBuV	Measurement Level dBuV/m	Margin dB	Limit dBuV/m
Horizontal					
Peak Detector:					
4824.000	2.428	46.310	48.739	-25.261	74.000
7236.000	9.177	43.180	52.357	-21.643	74.000
9648.000	10.019	39.920	49.940	-24.060	74.000
12060.000	13.220	41.000	54.220	-19.780	74.000
Average Detector:					
12060.000	13.220	28.580	41.800	-12.200	54.000
Vertical					
Peak Detector:					
4824.000	2.836	45.380	48.217	-25.783	74.000
7236.000	9.676	42.830	52.506	-21.494	74.000
9648.000	41.893	39.830	50.387	-23.613	74.000
12060.000	14.739	40.080	54.819	-19.181	74.000
Average Detector:					
12060.000	14.739	28.690	43.429	-10.571	54.000

Note:

1. All Readings below 1GHz are Quasi-Peak, above 1GHz are performed with peak and/or average measurements as necessary.
2. Peak measurements: RBW = 1MHz, VBW = 3 MHz, Sweep: Auto.
3. Average measurements: RBW = 1MHz, VBW = 10 Hz, Sweep: Auto.
4. Measurement Level = Reading Level + Correct Factor.
5. Correct Factor = Antenna factor + Cable loss – Amplifier gain.
6. The average measurement was not performed when the peak measured data under the limit of average detection.
7. The emission levels of other frequencies are very lower than the limit and not show in test report.

Product : AIS Class B Transponder
 Test Item : Harmonic Radiated Emission Data
 Test Site : No.3 OATS
 Test Mode : Mode 1: Transmit (802.11b 1Mbps) (2437 MHz)

Frequency MHz	Correct Factor dB	Reading Level dBuV	Measurement Level dBuV/m	Margin dB	Limit dBuV/m
Horizontal					
Peak Detector:					
4874.000	2.076	44.650	46.727	-27.273	74.000
7311.000	9.512	39.180	48.692	-25.308	74.000
9748.000	9.630	39.590	49.220	-24.780	74.000
Average Detector:					
--					
Vertical					
Peak Detector:					
4874.000	2.532	46.590	49.122	-24.878	74.000
7311.000	10.089	39.390	49.479	-24.521	74.000
9748.000	10.266	39.770	50.037	-23.963	74.000
Average Detector:					
--					

Note:

1. All Readings below 1GHz are Quasi-Peak, above 1GHz are performed with peak and/or average measurements as necessary.
2. Peak measurements: RBW = 1MHz, VBW = 3 MHz, Sweep: Auto.
3. Average measurements: RBW = 1MHz, VBW = 10 Hz, Sweep: Auto.
4. Measurement Level = Reading Level + Correct Factor.
5. Correct Factor = Antenna factor + Cable loss – Amplifier gain.
6. The average measurement was not performed when the peak measured data under the limit of average detection.
7. The emission levels of other frequencies are very lower than the limit and not show in test report.

Product : AIS Class B Transponder
 Test Item : Harmonic Radiated Emission Data
 Test Site : No.3 OATS
 Test Mode : Mode 1: Transmit (802.11b 1Mbps) (2462 MHz)

Frequency MHz	Correct Factor dB	Reading Level dBuV	Measurement Level dBuV/m	Margin dB	Limit dBuV/m
Horizontal					
Peak Detector:					
4924.000	2.191	43.970	46.161	-27.839	74.000
7386.000	10.373	39.170	49.544	-24.456	74.000
9848.000	9.964	40.160	50.124	-23.876	74.000
Average Detector:					
--					
Vertical					
Peak Detector:					
4924.000	2.805	44.710	47.515	-26.485	74.000
7386.000	11.180	39.030	50.210	-23.790	74.000
9848.000	10.801	39.380	50.181	-23.819	74.000
Average Detector:					
--					

Note:

1. All Readings below 1GHz are Quasi-Peak, above 1GHz are performed with peak and/or average measurements as necessary.
2. Peak measurements: RBW = 1MHz, VBW = 3 MHz, Sweep: Auto.
3. Average measurements: RBW = 1MHz, VBW = 10 Hz, Sweep: Auto.
4. Measurement Level = Reading Level + Correct Factor.
5. Correct Factor = Antenna factor + Cable loss – Amplifier gain.
6. The average measurement was not performed when the peak measured data under the limit of average detection.
7. The emission levels of other frequencies are very lower than the limit and not show in test report.

Product : AIS Class B Transponder
 Test Item : Harmonic Radiated Emission Data
 Test Site : No.3 OATS
 Test Mode : Mode 2: Transmit (802.11g 6Mbps) (2412MHz)

Frequency MHz	Correct Factor dB	Reading Level dBuV	Measurement Level dBuV/m	Margin dB	Limit dBuV/m
Horizontal					
Peak Detector:					
4824.000	2.428	43.830	46.259	-27.741	74.000
7236.000	9.177	40.460	49.637	-24.363	74.000
9648.000	10.019	39.750	49.770	-24.230	74.000
Average Detector:					
--					
Vertical					
Peak Detector:					
4824.000	2.836	43.590	46.427	-27.573	74.000
7236.000	9.676	41.680	51.356	-22.644	74.000
9648.000	10.556	39.730	50.287	-23.713	74.000
Average Detector:					
--					

Note:

1. All Readings below 1GHz are Quasi-Peak, above 1GHz are performed with peak and/or average measurements as necessary.
2. Peak measurements: RBW = 1MHz, VBW = 3 MHz, Sweep: Auto.
3. Average measurements: RBW = 1MHz, VBW = 10 Hz, Sweep: Auto.
4. Measurement Level = Reading Level + Correct Factor.
5. Correct Factor = Antenna factor + Cable loss – Amplifier gain.
6. The average measurement was not performed when the peak measured data under the limit of average detection.
7. The emission levels of other frequencies are very lower than the limit and not show in test report.

Product : AIS Class B Transponder
 Test Item : Harmonic Radiated Emission Data
 Test Site : No.3 OATS
 Test Mode : Mode 2: Transmit (802.11g 6Mbps) (2437 MHz)

Frequency	Correct	Reading	Measurement	Margin	Limit
MHz	Factor	Level	Level	dB	dBuV/m
	dB	dBuV	dBuV/m		

Horizontal

Peak Detector:

4874.000	2.076	42.780	44.857	-29.143	74.000
7311.000	9.512	39.760	49.272	-24.728	74.000
9748.000	9.630	39.550	49.180	-24.820	74.000

Average Detector:

--

Peak Detector:

4874.000	2.532	44.700	47.232	-26.768	74.000
7311.000	10.089	41.330	51.419	-22.581	74.000
9748.000	10.266	39.580	49.847	-24.153	74.000

Average Detector:

--

Note:

1. All Readings below 1GHz are Quasi-Peak, above 1GHz are performed with peak and/or average measurements as necessary.
2. Peak measurements: RBW = 1MHz, VBW = 3 MHz, Sweep: Auto.
3. Average measurements: RBW = 1MHz, VBW = 10 Hz, Sweep: Auto.
4. Measurement Level = Reading Level + Correct Factor.
5. Correct Factor = Antenna factor + Cable loss – Amplifier gain.
6. The average measurement was not performed when the peak measured data under the limit of average detection.
7. The emission levels of other frequencies are very lower than the limit and not show in test report.

Product : AIS Class B Transponder
 Test Item : Harmonic Radiated Emission Data
 Test Site : No.3 OATS
 Test Mode : Mode 2: Transmit (802.11g 6Mbps) (2462 MHz)

Frequency MHz	Correct Factor dB	Reading Level dBuV	Measurement Level dBuV/m	Margin dB	Limit dBuV/m
Horizontal					
Peak Detector:					
4924.000	2.191	42.020	44.211	-29.789	74.000
7386.000	10.373	39.050	49.424	-24.576	74.000
9848.000	9.964	40.370	50.334	-23.666	74.000
Average Detector:					
--					
Vertical					
Peak Detector:					
4924.000	2.805	44.110	46.915	-27.085	74.000
7386.000	11.180	41.290	52.470	-21.530	74.000
9848.000	10.801	39.800	50.601	-23.399	74.000

Average Detector:

--

Note:

1. All Readings below 1GHz are Quasi-Peak, above 1GHz are performed with peak and/or average measurements as necessary.
2. Peak measurements: RBW = 1MHz, VBW = 3 MHz, Sweep: Auto.
3. Average measurements: RBW = 1MHz, VBW = 10 Hz, Sweep: Auto.
4. Measurement Level = Reading Level + Correct Factor.
5. Correct Factor = Antenna factor + Cable loss – Amplifier gain.
6. The average measurement was not performed when the peak measured data under the limit of average detection.
7. The emission levels of other frequencies are very lower than the limit and not show in test report.

Product : AIS Class B Transponder
 Test Item : Harmonic Radiated Emission Data
 Test Site : No.3 OATS
 Test Mode : Mode 3: Transmit (802.11n MCS0 7.2Mbps 20M-BW)(2412MHz)

Frequency MHz	Correct Factor dB	Reading Level dBUV	Measurement Level dBUV/m	Margin dB	Limit dBUV/m
Horizontal					
Peak Detector:					
4824.000	35.550	42.120	44.549	-29.451	74.000
7236.000	40.724	39.660	48.837	-25.163	74.000
9648.000	41.356	40.190	50.210	-23.790	74.000
Average Detector:					
--					
Vertical					
Peak Detector:					
4824.000	2.836	42.770	45.607	-28.393	74.000
7236.000	9.676	39.620	49.296	-24.704	74.000
9648.000	10.556	40.050	50.607	-23.393	74.000
Average Detector:					
--					

Note:

1. All Readings below 1GHz are Quasi-Peak, above 1GHz are performed with peak and/or average measurements as necessary.
2. Peak measurements: RBW = 1MHz, VBW = 3 MHz, Sweep: Auto.
3. Average measurements: RBW = 1MHz, VBW = 10 Hz, Sweep: Auto.
4. Measurement Level = Reading Level + Correct Factor.
5. Correct Factor = Antenna factor + Cable loss – Amplifier gain.
6. The average measurement was not performed when the peak measured data under the limit of average detection.
7. The emission levels of other frequencies are very lower than the limit and not show in test report.

Product : AIS Class B Transponder
 Test Item : Harmonic Radiated Emission Data
 Test Site : No.3 OATS
 Test Mode : Mode 3: Transmit (802.11n MCS0 7.2Mbps 20M-BW) (2437 MHz)

Frequency MHz	Correct Factor dB	Reading Level dBUV	Measurement Level dBUV/m	Margin dB	Limit dBUV/m
Horizontal					
Peak Detector:					
4874.000	2.076	42.400	44.477	-29.523	74.000
7311.000	9.512	39.130	48.642	-25.358	74.000
9748.000	9.630	39.740	49.370	-24.630	74.000
Average Detector:					
--					
Vertical					
Peak Detector:					
4874.000	35.627	44.670	47.202	-26.798	74.000
7311.000	41.330	40.070	50.159	-23.841	74.000
9748.000	42.198	39.630	49.897	-24.103	74.000
Average Detector:					
--					

Note:

1. All Readings below 1GHz are Quasi-Peak, above 1GHz are performed with peak and/or average measurements as necessary.
2. Peak measurements: RBW = 1MHz, VBW = 3 MHz, Sweep: Auto.
3. Average measurements: RBW = 1MHz, VBW = 10 Hz, Sweep: Auto.
4. Measurement Level = Reading Level + Correct Factor.
5. Correct Factor = Antenna factor + Cable loss – Amplifier gain.
6. The average measurement was not performed when the peak measured data under the limit of average detection.
7. The emission levels of other frequencies are very lower than the limit and not show in test report.

Product : AIS Class B Transponder
 Test Item : Harmonic Radiated Emission Data
 Test Site : No.3 OATS
 Test Mode : Mode 3: Transmit (802.11n MCS0 7.2Mbps 20M-BW) (2462 MHz)

Frequency MHz	Correct Factor dB	Reading Level dBuV	Measurement Level dBuV/m	Margin dB	Limit dBuV/m
Horizontal					
Peak Detector:					
4924.000	2.191	42.010	44.201	-29.799	74.000
7386.000	10.373	39.370	49.744	-24.256	74.000
9848.000	9.964	39.860	49.824	-24.176	74.000
Average Detector:					
--					
Vertical					
Peak Detector:					
4924.000	2.805	41.940	44.745	-29.255	74.000
7386.000	10.373	38.960	49.334	-24.666	74.000
9848.000	10.801	40.260	51.061	-22.939	74.000

Average Detector:

--

Note:

1. All Readings below 1GHz are Quasi-Peak, above 1GHz are performed with peak and/or average measurements as necessary.
2. Peak measurements: RBW = 1MHz, VBW = 3 MHz, Sweep: Auto.
3. Average measurements: RBW = 1MHz, VBW = 10 Hz, Sweep: Auto.
4. Measurement Level = Reading Level + Correct Factor.
5. Correct Factor = Antenna factor + Cable loss – Amplifier gain.
6. The average measurement was not performed when the peak measured data under the limit of average detection.
7. The emission levels of other frequencies are very lower than the limit and not show in test report.

Product : AIS Class B Transponder
 Test Item : General Radiated Emission Data
 Test Site : No.3 OATS
 Test Mode : Mode 1: Transmit (802.11b 1Mbps)(2437 MHz)

Frequency MHz	Correct Factor dB	Reading Level dBuV	Measurement Level dBuV/m	Margin dB	Limit dBuV/m
Horizontal					
78.480	9.579	19.800	29.378	-10.622	40.000
140.620	14.857	17.800	32.658	-10.842	43.500
165.890	13.814	10.800	24.614	-18.886	43.500
288.000	17.880	24.000	41.880	-4.120	46.000
432.000	22.373	21.100	43.473	-2.527	46.000
624.000	25.988	10.100	36.087	-9.913	46.000
816.000	28.610	10.100	38.710	-7.290	46.000
981.920	30.634	22.400	53.034	-0.966	54.000
Vertical					
39.770	15.839	13.200	29.038	-10.962	40.000
42.960	14.513	16.600	31.113	-8.887	40.000
78.180	9.553	23.000	32.554	-7.446	40.000
110.500	15.189	18.700	33.889	-9.611	43.500
140.280	14.882	22.800	37.682	-5.818	43.500
288.000	17.880	24.300	42.180	-3.820	46.000
432.000	22.373	21.200	43.573	-2.427	46.000
624.000	25.988	13.900	39.887	-6.113	46.000
981.920	30.634	13.700	44.334	-9.666	54.000

Note:

1. All Readings below 1GHz are Quasi-Peak, above 1GHz are performed with peak and/or average measurements as necessary.
2. Peak measurements: RBW = 1MHz, VBW = 3 MHz, Sweep: Auto.
3. Average measurements: RBW = 1MHz, VBW = 10 Hz, Sweep: Auto.
4. Measurement Level = Reading Level + Correct Factor.
5. Correct Factor = Antenna factor + Cable loss – Amplifier gain.
6. The average measurement was not performed when the peak measured data under the limit of average detection.
7. The emission levels of other frequencies are very lower than the limit and not show in test report.
8. No emission found between lowest internal used/generated frequency to 30MHz.

Product : AIS Class B Transponder
 Test Item : General Radiated Emission Data
 Test Site : No.3 OATS
 Test Mode : Mode 2: Transmit (802.11g 6Mbps)(2437 MHz)

Frequency MHz	Correct Factor dB	Reading Level dBuV	Measurement Level dBuV/m	Margin dB	Limit dBuV/m
Horizontal					
78.480	9.579	19.400	28.978	-11.022	40.000
140.620	14.857	21.700	36.558	-6.942	43.500
192.000	13.381	14.500	27.881	-15.619	43.500
288.000	17.880	23.600	41.480	-4.520	46.000
312.000	18.721	19.800	38.522	-7.478	46.000
432.000	22.373	21.200	43.573	-2.427	46.000
624.000	25.988	10.700	36.687	-9.313	46.000
981.920	30.634	22.200	52.834	-1.166	54.000
Vertical					
39.770	15.839	13.200	29.038	-10.962	40.000
42.960	14.513	17.000	31.513	-8.487	40.000
110.500	15.189	19.700	34.889	-8.611	43.500
140.280	14.882	23.700	38.582	-4.918	43.500
288.000	17.880	23.700	41.580	-4.420	46.000
432.000	22.373	21.600	43.973	-2.027	46.000
634.000	26.114	8.200	34.314	-11.686	46.000
981.920	30.634	13.300	43.934	-10.066	54.000
981.920	30.634	10.700	41.334	-12.666	54.000

Note:

1. All Readings below 1GHz are Quasi-Peak, above 1GHz are performed with peak and/or average measurements as necessary.
2. Peak measurements: RBW = 1MHz, VBW = 3 MHz, Sweep: Auto.
3. Average measurements: RBW = 1MHz, VBW = 10 Hz, Sweep: Auto.
4. Measurement Level = Reading Level + Correct Factor.
5. Correct Factor = Antenna factor + Cable loss – Amplifier gain.
6. The average measurement was not performed when the peak measured data under the limit of average detection.
7. The emission levels of other frequencies are very lower than the limit and not show in test report.
8. No emission found between lowest internal used/generated frequency to 30MHz.

Product : AIS Class B Transponder
 Test Item : General Radiated Emission Data
 Test Site : No.3 OATS
 Test Mode : Mode 3: Transmit (802.11n MCS0 7.2Mbps 20M-BW)(2437 MHz)

Frequency MHz	Correct Factor dB	Reading Level dBuV	Measurement Level dBuV/m	Margin dB	Limit dBuV/m
Horizontal					
78.480	9.579	19.000	28.578	-11.422	40.000
140.620	14.857	19.400	34.258	-9.242	43.500
192.000	13.381	13.200	26.581	-16.919	43.500
288.000	17.880	24.900	42.780	-3.220	46.000
432.000	22.373	21.700	44.073	-1.927	46.000
624.000	25.988	9.500	35.487	-10.513	46.000
816.000	28.610	10.100	38.710	-7.290	46.000
981.920	30.634	21.900	52.534	-1.466	54.000
Vertical					
39.770	15.839	13.500	29.338	-10.662	40.000
42.010	14.892	16.100	30.991	-9.009	40.000
78.180	9.553	22.400	31.954	-8.046	40.000
110.500	15.189	18.300	33.489	-10.011	43.500
140.280	14.882	22.700	37.582	-5.918	43.500
288.000	17.880	23.600	41.480	-4.520	46.000
432.000	22.373	20.700	43.073	-2.927	46.000
672.000	26.560	10.300	36.860	-9.140	46.000
981.920	30.634	13.200	43.834	-10.166	54.000

Note:

1. All Readings below 1GHz are Quasi-Peak, above 1GHz are performed with peak and/or average measurements as necessary.
2. Peak measurements: RBW = 1MHz, VBW = 3 MHz, Sweep: Auto.
3. Average measurements: RBW = 1MHz, VBW = 10 Hz, Sweep: Auto.
4. Measurement Level = Reading Level + Correct Factor.
5. Correct Factor = Antenna factor + Cable loss – Amplifier gain.
6. The average measurement was not performed when the peak measured data under the limit of average detection.
7. The emission levels of other frequencies are very lower than the limit and not show in test report.
8. No emission found between lowest internal used/generated frequency to 30MHz.

5. RF antenna conducted test

5.1. Test Equipment

	Equipment	Manufacturer	Model No./Serial No.	Last Cal.
	Spectrum Analyzer	R&S	FSP40 / 100170	Jun, 2013
	Spectrum Analyzer	Agilent	E4407B / US39440758	Jun, 2013
X	Spectrum Analyzer	Agilent	N9010A / MY48030495	Apr., 2013

- Note:
1. All equipments are calibrated with traceable calibrations. Each calibration is traceable to the national or international standards.
 2. The test instruments marked with “X” are used to measure the final test results.

5.2. Test Setup

RF antenna Conducted Measurement:

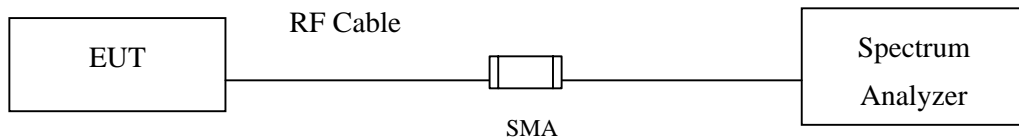

5.3. Limits

In any 100 kHz bandwidth outside the frequency band in which the spread spectrum intentional radiator is operating, the radio frequency power that is produced by the intentional radiator shall be at least 20 dB below that in the 100 kHz bandwidth within the band that contains the highest level of the desired power, based on either an RF conducted or a radiated measurement. Attenuation below the general limits specified in Section 15.209(a) is not required. In addition, radiated emissions which fall in the restricted bands, as defined in Section 15.205(a), must also comply with the radiated emission limits specified in Section 15.209(a) (see Section 15.205(c)).

5.4. Test Procedure

The EUT was tested according to DTS test procedure of KDB558074 for compliance to FCC 47CFR 15.247 requirements.

Set RBW = 100 kHz, Set VBW > RBW, scan up through 10th harmonic.

5.5. Uncertainty

The measurement uncertainty

Conducted is defined as $\pm 1.27\text{dB}$

5.6. Test Result of RF antenna conducted test

Product : AIS Class B Transponder
Test Item : RF antenna conducted test
Test Site : No.3 OATS
Test Mode : Mode 1: Transmit (802.11b 1Mbps)

Channel 01 (2412MHz)

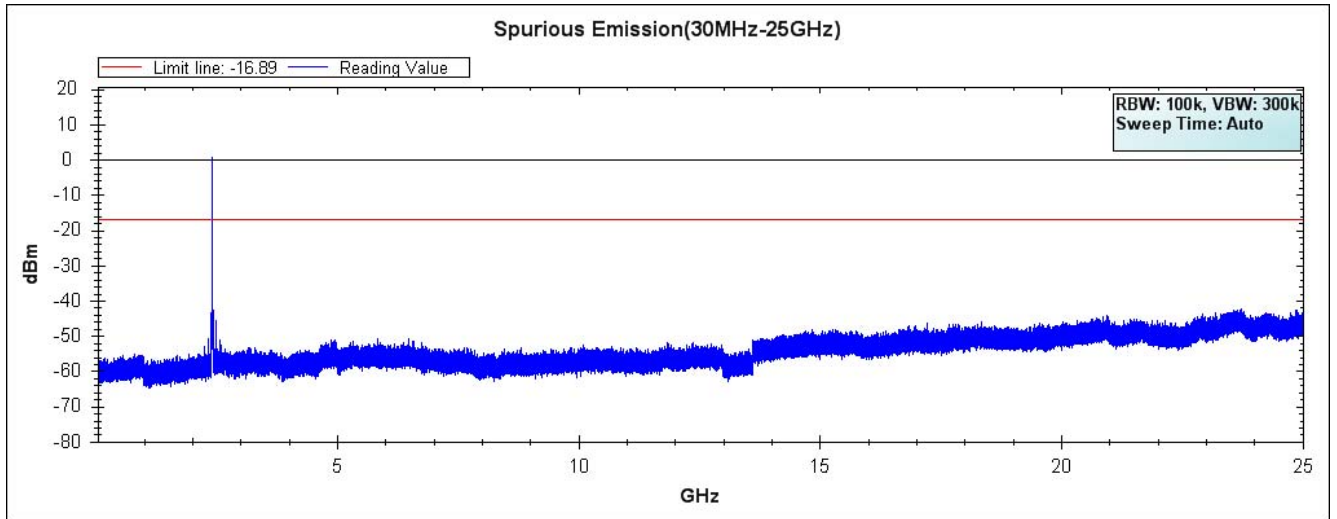

Channel 06 (2437MHz)

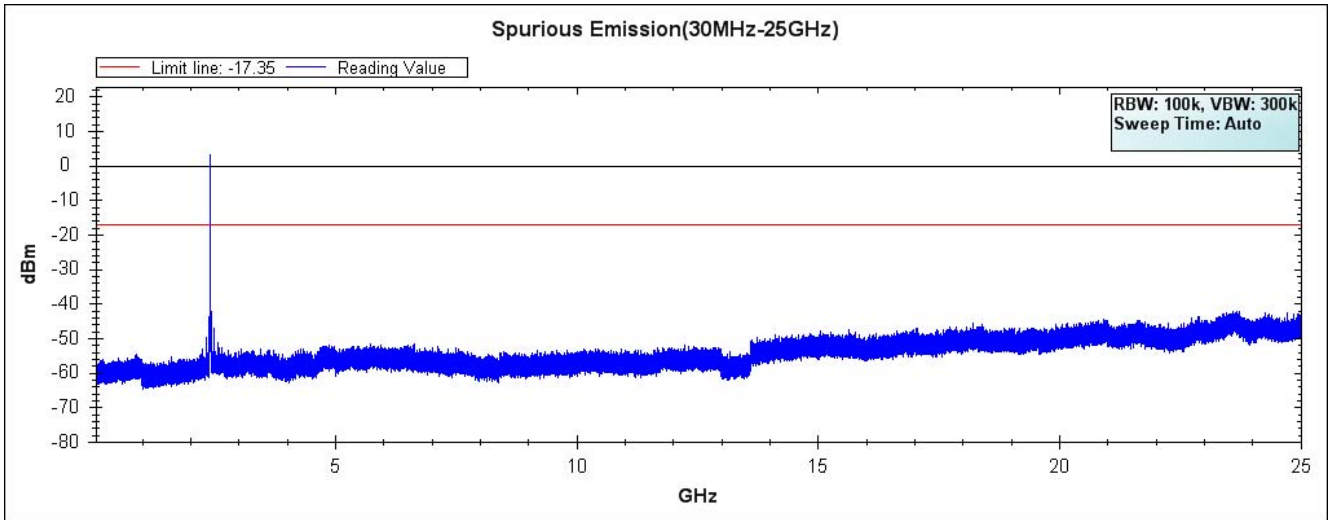

Channel 11 (2462MHz)

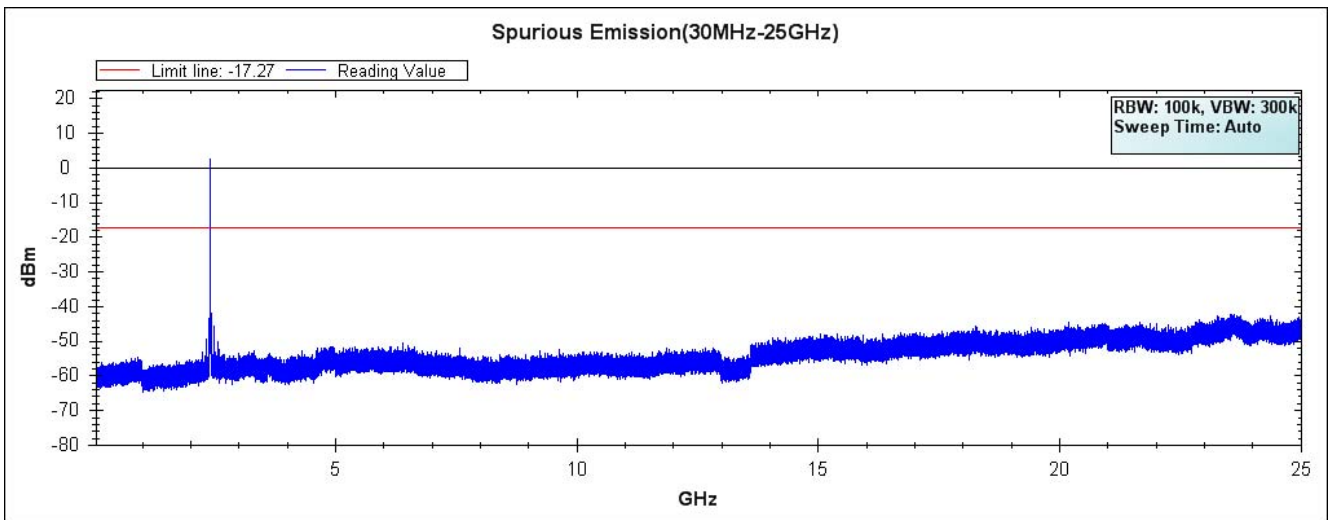

Product : AIS Class B Transponder
Test Item : RF Antenna Conducted Spurious
Test Site : No.3 OATS
Test Mode : Mode 2: Transmit (802.11g 6Mbps)

Channel 01 (2412MHz)

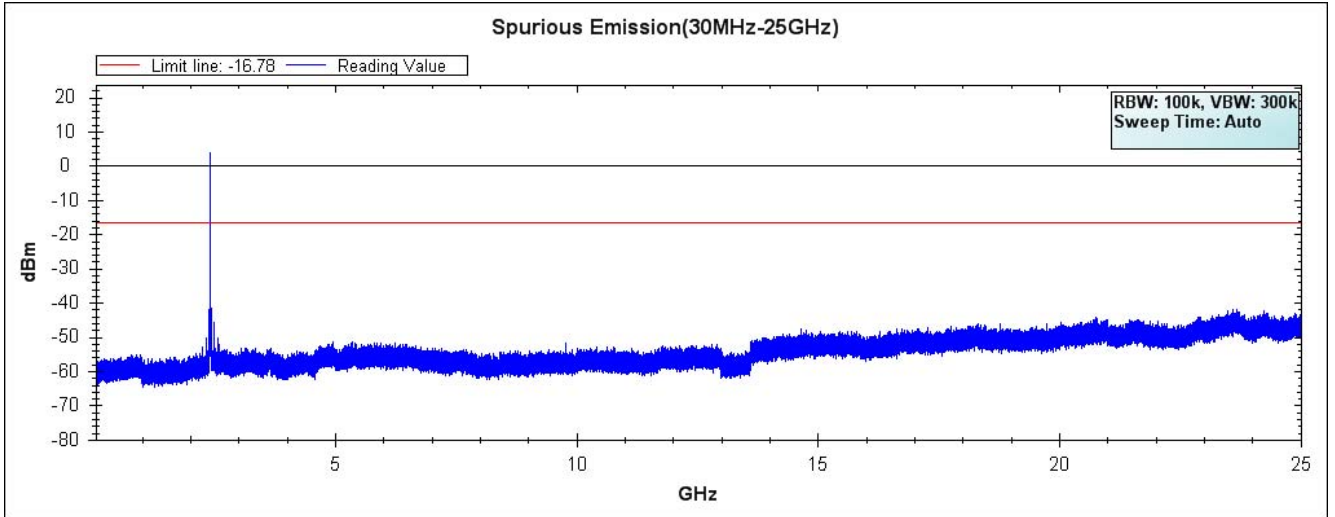

Channel 06 (2437MHz)

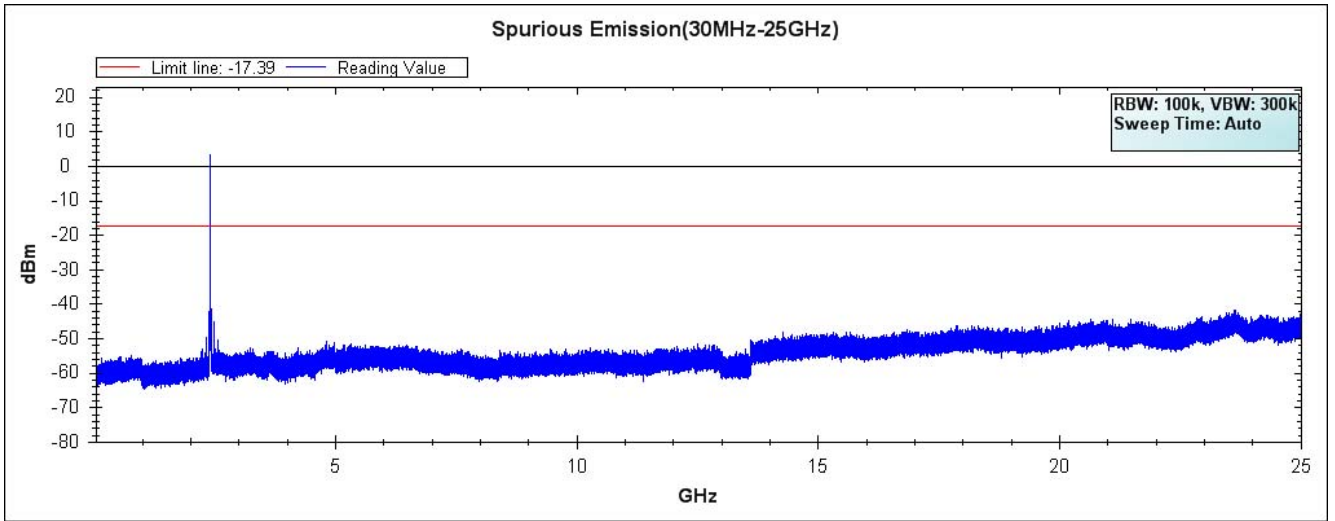

Channel 11 (2462MHz)

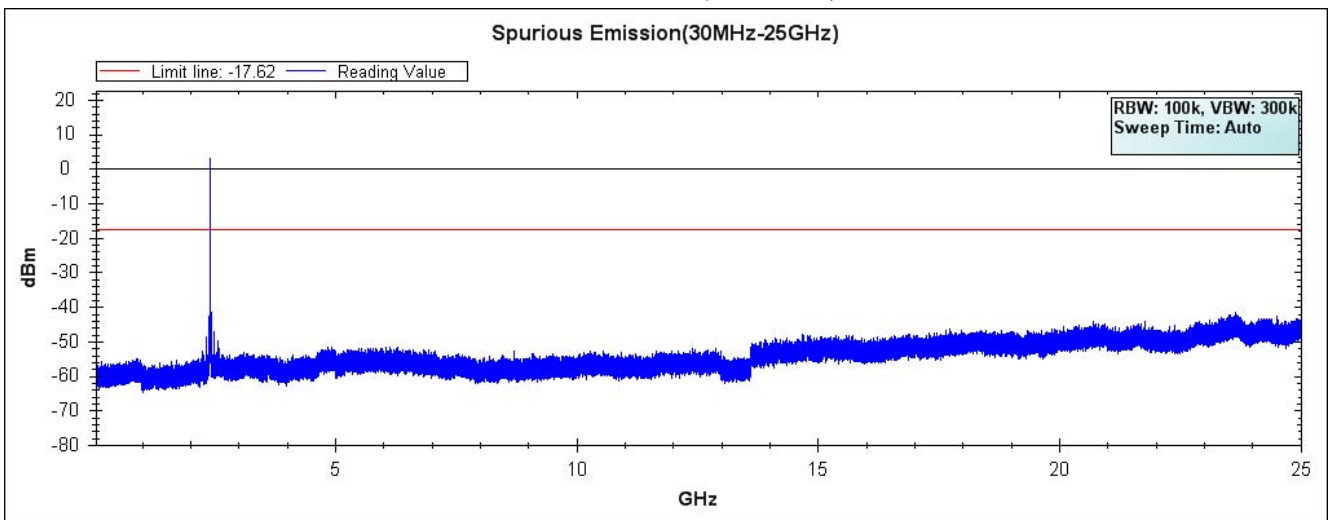

Product : AIS Class B Transponder
Test Item : RF Antenna Conducted Spurious
Test Site : No.3 OATS
Test Mode : Mode 3: Transmit (802.11n MCS0 7.2Mbps 20M-BW)

Channel 01 (2412MHz)

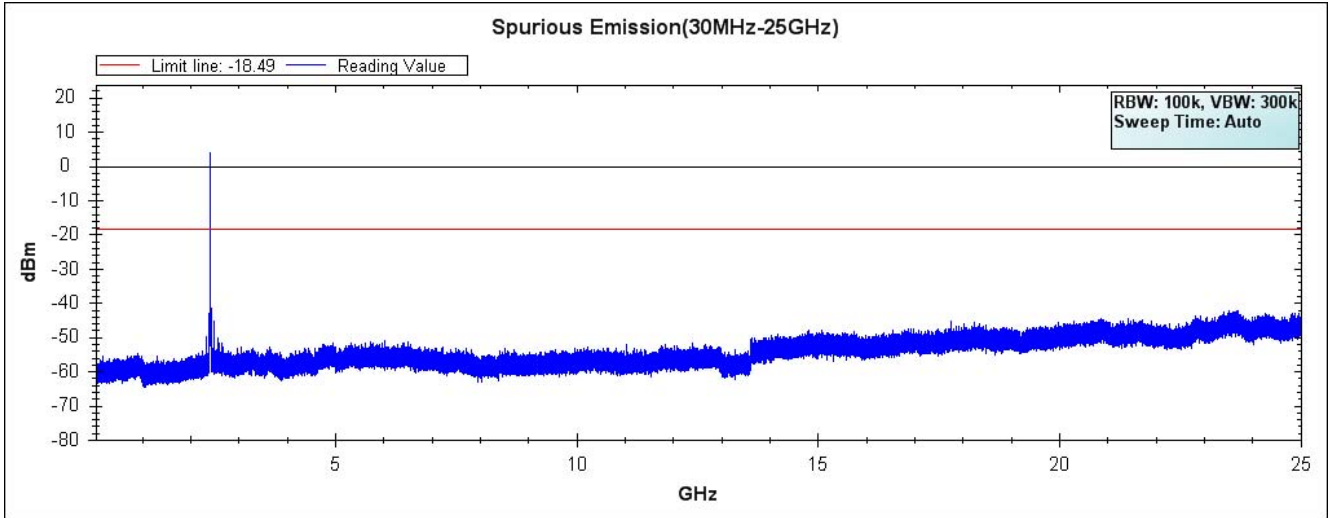

Channel 06 (2437MHz)

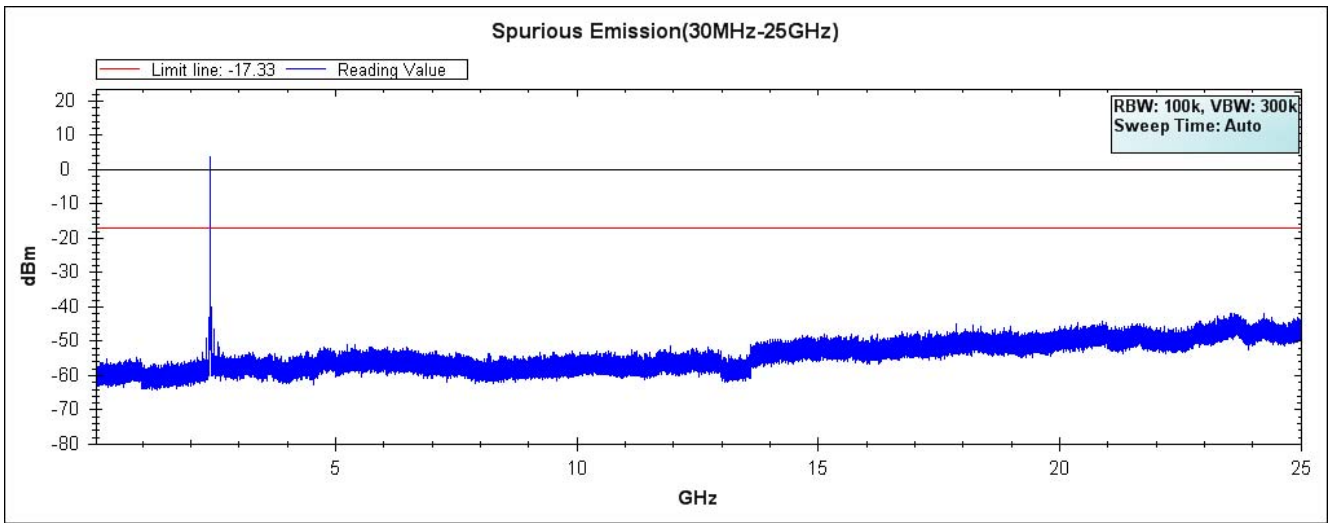

Channel 11 (2462MHz)

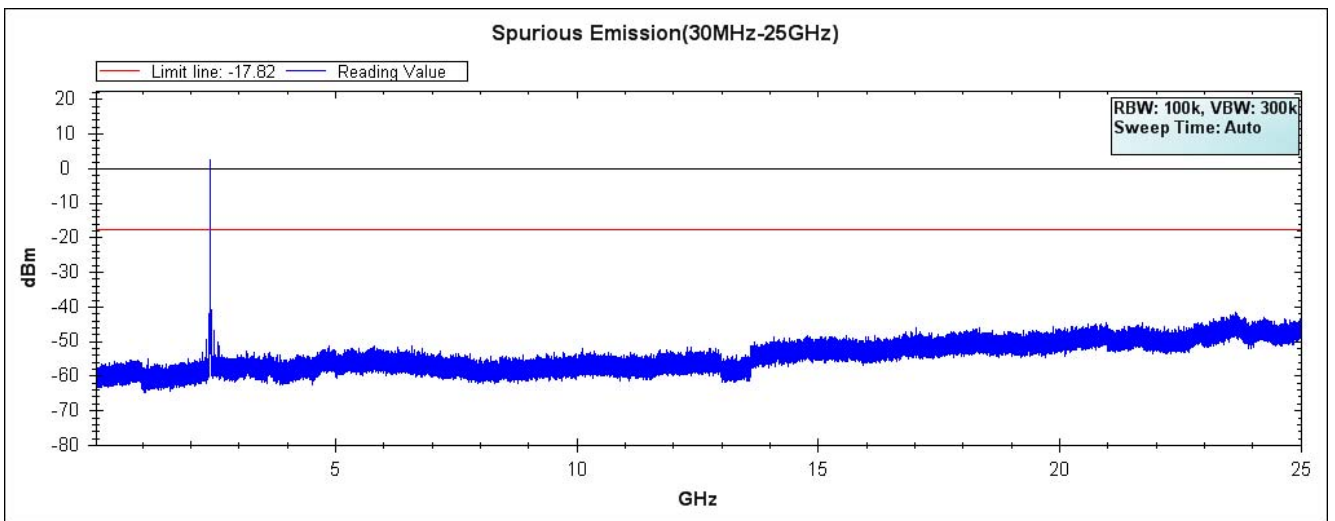

6. Band Edge

6.1. Test Equipment

+RF Radiated Measurement:

The following test equipments are used during the band edge tests:

Test Site	Equipment	Manufacturer	Model No./Serial No.	Last Cal.
☒ Site # 3	Bilog Antenna	Schaffner Chase	CBL6112B/2673	Sep., 2013
	X Horn Antenna	Schwarzbeck	BBHA9120D/D305	Sep., 2013
	Horn Antenna	Schwarzbeck	BBHA9170/208	Jul., 2013
	X Pre-Amplifier	Agilent	8447D/2944A09549	Sep., 2013
	X Spectrum Analyzer	Agilent	E4407B / US39440758	May, 2013
	Test Receiver	R & S	ESCS 30/ 825442/018	Sep., 2013
	X Coaxial Cable	Quietek	QTK-CABLE/ CAB5	Feb., 2013
	X Controller	Quietek	QTK-CONTROLLER/ CTRL3	N/A
	X Coaxial Switch	Anritsu	MP59B/6200265729	N/A

- Note:
1. All instruments are calibrated every one year.
 2. The test instruments marked by "X" are used to measure the final test results.

6.2. Test Setup

RF Radiated Measurement:

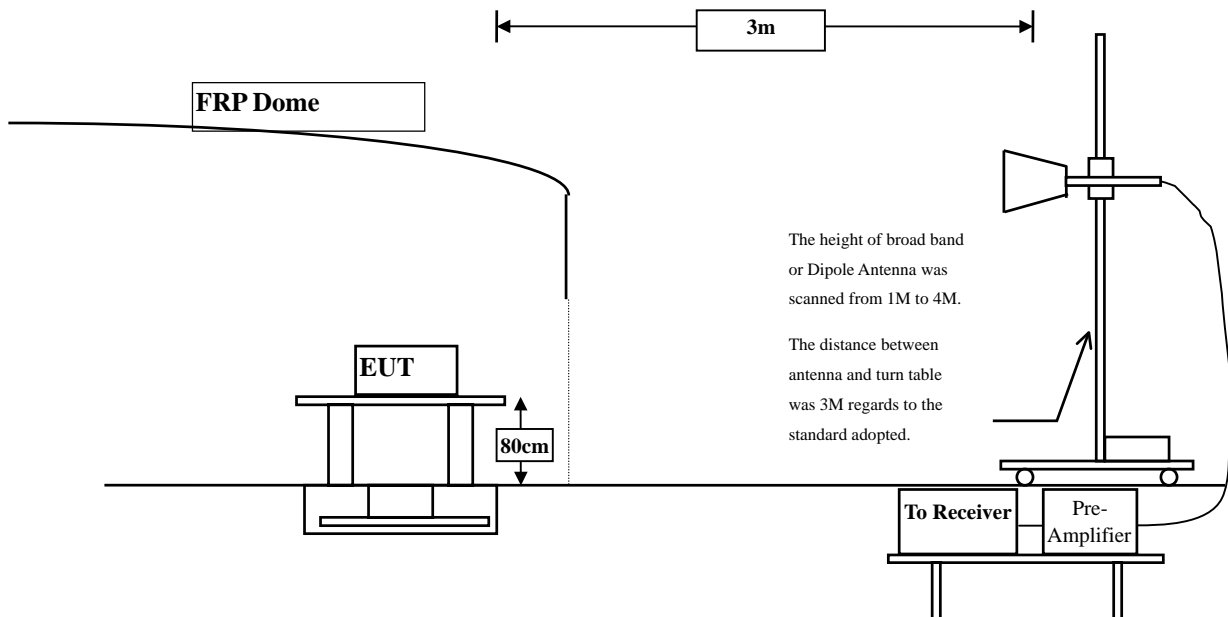

6.3. Limits

Emissions radiated outside of the specified frequency bands, except for harmonics, shall be attenuated by at least 20dB below the level of the fundamental or to the general radiated emission limits in paragraph 15.209, whichever is the lesser attenuation.

6.4. Test Procedure

The EUT was setup according to ANSI C63.10: 2009 and tested according to DTS test procedure of KDB558074 for compliance to FCC 47CFR 15.247 requirements.

The EUT is placed on a turn table which is 0.8 meter above ground. The turn table is rotated 360 degrees to determine the position of the maximum emission level. The EUT was positioned such that the distance from antenna to the EUT was 3 meters.

The antenna is scanned from 1 meter to 4 meters to find out the maximum emission level. This is repeated for both horizontal and vertical polarization of the antenna. In order to find the maximum emission, all of the interface cables were manipulated according to ANSI C63.10: 2009 on radiated measurement.

6.5. Uncertainty

± 3.9 dB above 1GHz

± 3.8 dB below 1GHz

6.6. Test Result of Band Edge

Product : AIS Class B Transponder
 Test Item : Band Edge Data
 Test Site : No.3 OATS
 Test Mode : Mode 1: Transmit (802.11b 1Mbps)

RF Radiated Measurement (Horizontal):

Channel No.	Frequency (MHz)	Correct Factor (dB)	Reading Level (dBuV)	Emission Level (dBuV/m)	Peak Limit (dBuV/m)	Average Limit (dBuV/m)	Result
01 (Peak)	2379.600	31.469	26.111	57.580	74.00	54.00	Pass
01 (Peak)	2390.000	31.509	25.051	56.560	74.00	54.00	Pass
01 (Peak)	2413.400	31.649	65.907	97.556	--	--	Pass
01 (Average)	2379.600	31.469	12.268	43.737	74.00	54.00	Pass
01 (Average)	2390.000	31.509	13.021	44.530	74.00	54.00	Pass
01 (Average)	2412.800	31.645	58.263	89.907	--	--	Pass

Figure Channel 01: Horizontal (Peak)

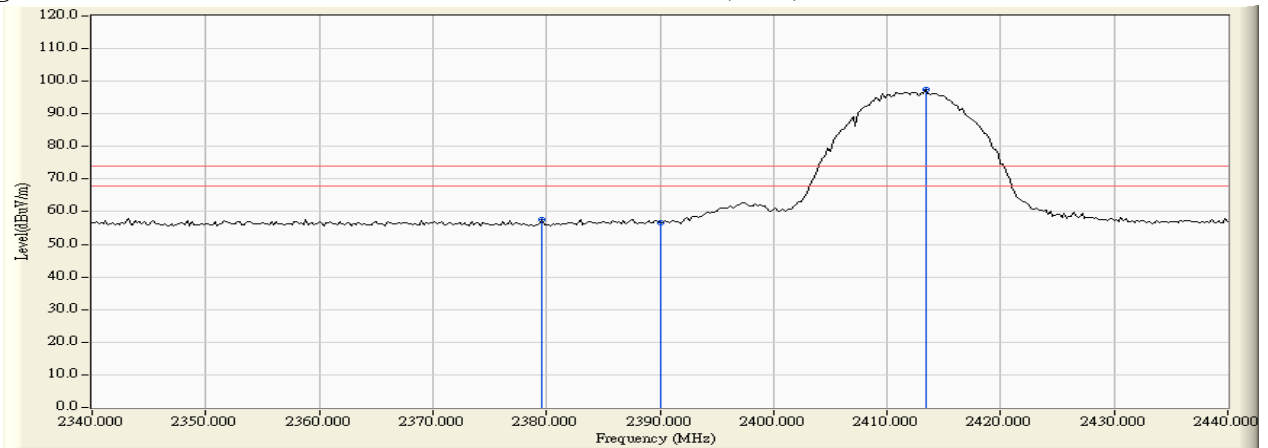

Figure Channel 01: Horizontal (Average)



- Note: 1. All readings above 1GHz are performed with peak and/or average measurements as necessary.
 2. Peak measurements: RBW = 1MHz, VBW = 3 MHz, Sweep: Auto.
 3. Average measurements: RBW = 1MHz, VBW = 10 Hz, Sweep: Auto.
 4. “ * ”, means this data is the worst emission level.
 5. Measurement Level = Reading Level + Correct Factor.
 6. The average measurement was not performed when the peak measured data under the limit of average detection.

Product : AIS Class B Transponder
 Test Item : Band Edge Data
 Test Site : No.3 OATS
 Test Mode : Mode 1: Transmit (802.11b 1Mbps)

RF Radiated Measurement (Vertical):

Channel No.	Frequency (MHz)	Correct Factor (dB)	Reading Level (dBuV)	Emission Level (dBuV/m)	Peak Limit (dBuV/m)	Average Limit (dBuV/m)	Result
01 (Peak)	2346.400	31.117	27.141	58.258	74.00	54.00	Pass
01 (Peak)	2386.800	30.930	26.945	57.875	74.00	54.00	Pass
01 (Peak)	2390.000	30.915	26.594	57.509	74.00	54.00	Pass
01 (Peak)	2413.600	30.960	69.423	100.383	--	--	Pass
01 (Average)	2346.400	31.117	12.463	43.580	74.00	54.00	Pass
01 (Average)	2386.800	30.930	15.889	46.819	74.00	54.00	Pass
01 (Average)	2390.000	30.915	15.165	46.080	74.00	54.00	Pass
01 (Average)	2412.800	30.955	61.914	92.869	--	--	Pass

Figure Channel 01: Vertical (Peak)

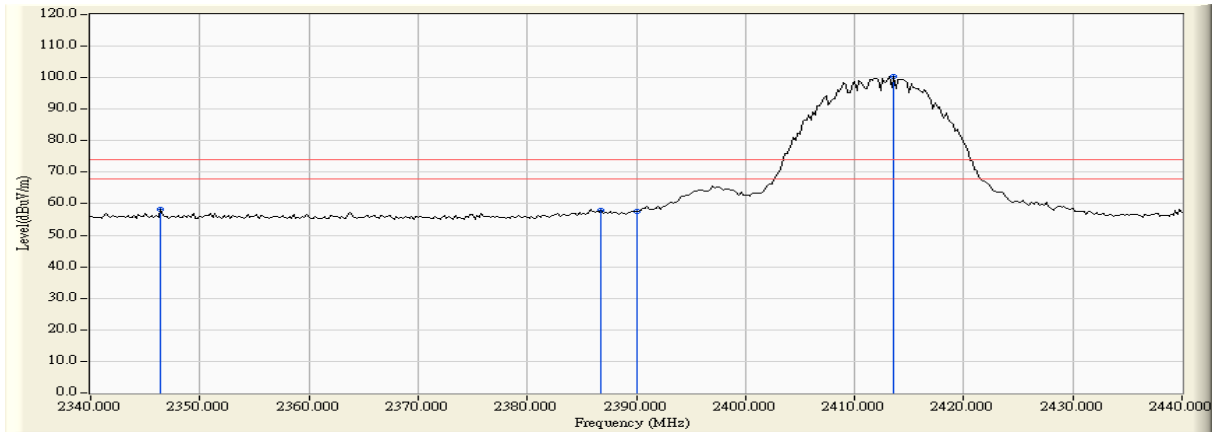
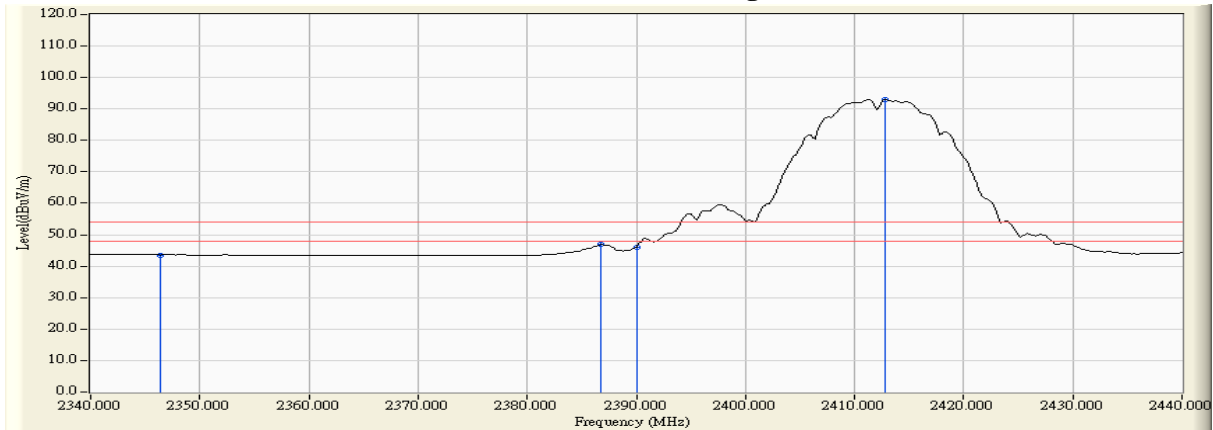

Figure Channel 01: Vertical (Average)



- Note: 1. All readings above 1GHz are performed with peak and/or average measurements as necessary.
 2. Peak measurements: RBW = 1MHz, VBW = 3 MHz, Sweep: Auto.
 3. Average measurements: RBW = 1MHz, VBW = 10 Hz, Sweep: Auto.
 4. “ * ”, means this data is the worst emission level.
 5. Measurement Level = Reading Level + Correct Factor.
 6. The average measurement was not performed when the peak measured data under the limit of average detection.

Product : AIS Class B Transponder
 Test Item : Band Edge Data
 Test Site : No.3 OATS
 Test Mode : Mode 1: Transmit (802.11b 1Mbps)

RF Radiated Measurement (Horizontal):

Channel No.	Frequency (MHz)	Correct Factor (dB)	Reading Level (dBuV)	Emission Level (dBuV/m)	Peak Limit (dBuV/m)	Average Limit (dBuV/m)	Result
11 (Peak)	2463.700	32.032	60.720	92.752	--	--	Pass
11 (Peak)	2483.500	32.182	24.275	56.457	74.00	54.00	Pass
11 (Peak)	2487.700	32.213	25.063	57.277	74.00	54.00	Pass
11 (Average)	2461.300	32.014	54.259	86.273	--	--	Pass
11 (Average)	2483.500	32.182	12.194	44.376	74.00	54.00	Pass
11 (Average)	2487.700	32.213	12.183	44.397	74.00	54.00	Pass

Figure Channel 11: Horizontal (Peak)

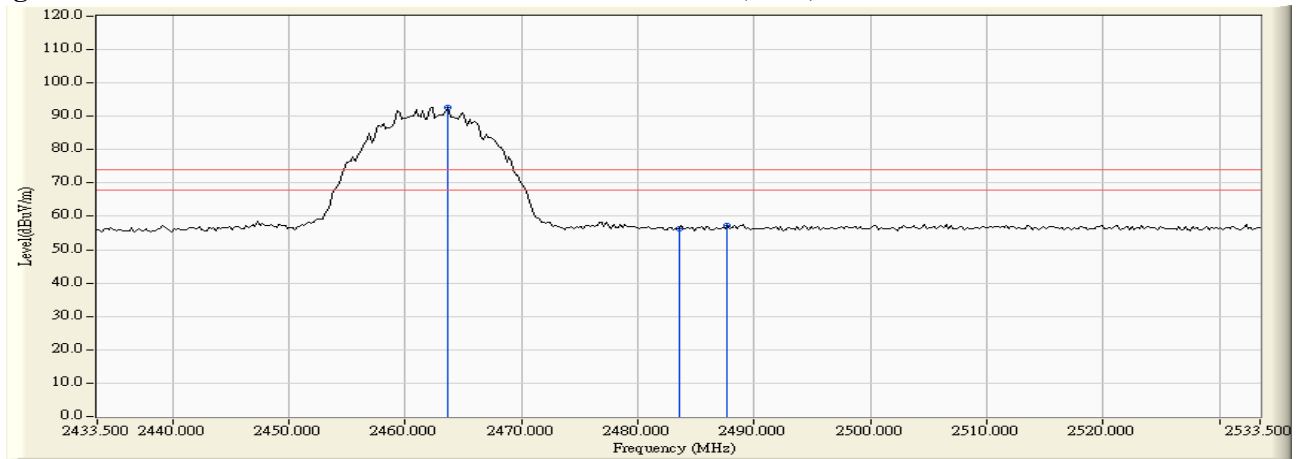
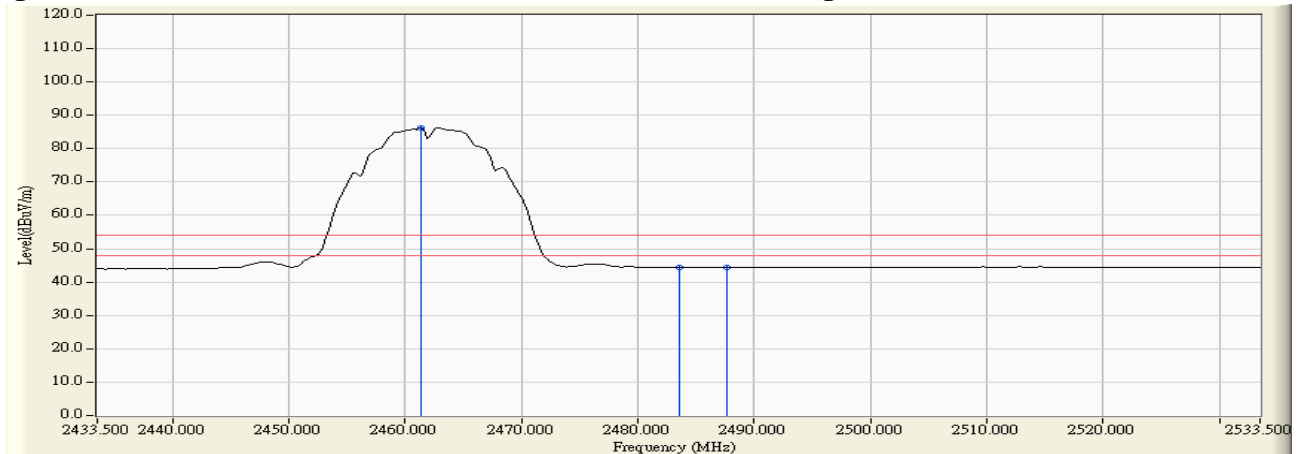

Figure Channel 11: Horizontal (Average)



- Note:1. All readings above 1GHz are performed with peak and/or average measurements as necessary.
 2. Peak measurements: RBW = 1MHz, VBW = 3 MHz, Sweep: Auto.
 3. Average measurements: RBW = 1MHz, VBW = 10 Hz, Sweep: Auto.
 4. “ * ”, means this data is the worst emission level.
 5. Measurement Level = Reading Level + Correct Factor.
 6. The average measurement was not performed when the peak measured data under the limit of average detection.

Product : AIS Class B Transponder
 Test Item : Band Edge Data
 Test Site : No.3 OATS
 Test Mode : Mode 1: Transmit (802.11b 1Mbps)

RF Radiated Measurement (Vertical):

Channel No.	Frequency (MHz)	Correct Factor (dB)	Reading Level (dBuV)	Emission Level (dBuV/m)	Peak Limit (dBuV/m)	Average Limit (dBuV/m)	Result
11 (Peak)	2463.300	31.299	67.291	98.590	--	--	Pass
11 (Peak)	2483.500	31.435	24.506	55.941	74.00	54.00	Pass
11 (Peak)	2493.100	31.501	25.986	57.486	74.00	54.00	Pass
11 (Average)	2462.700	31.295	60.700	91.995	--	--	Pass
11 (Average)	2483.500	31.435	12.529	43.964	74.00	54.00	Pass
11 (Average)	2493.100	31.501	12.238	43.738	74.00	54.00	Pass

Figure Channel 11: Vertical (Peak)

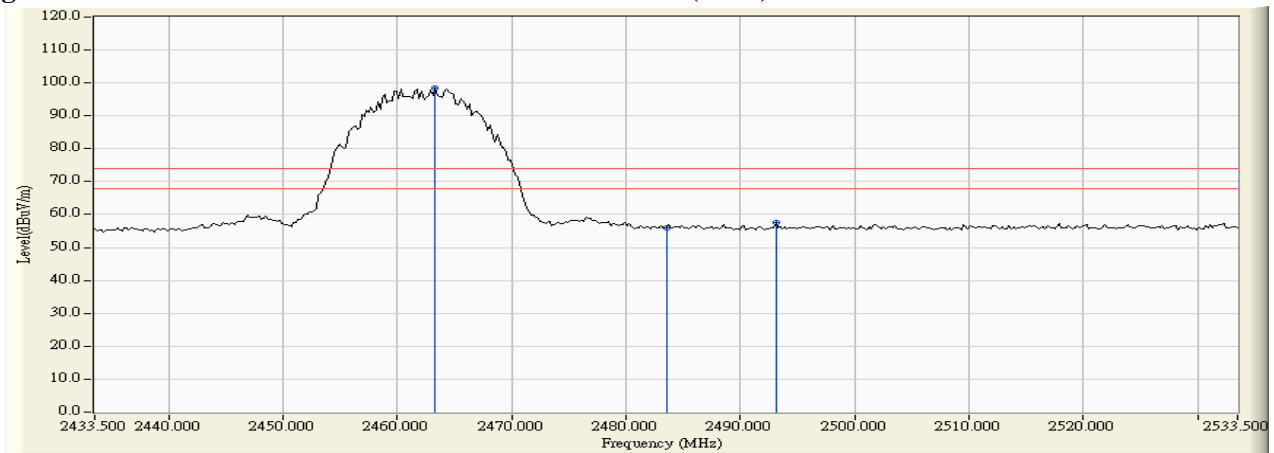
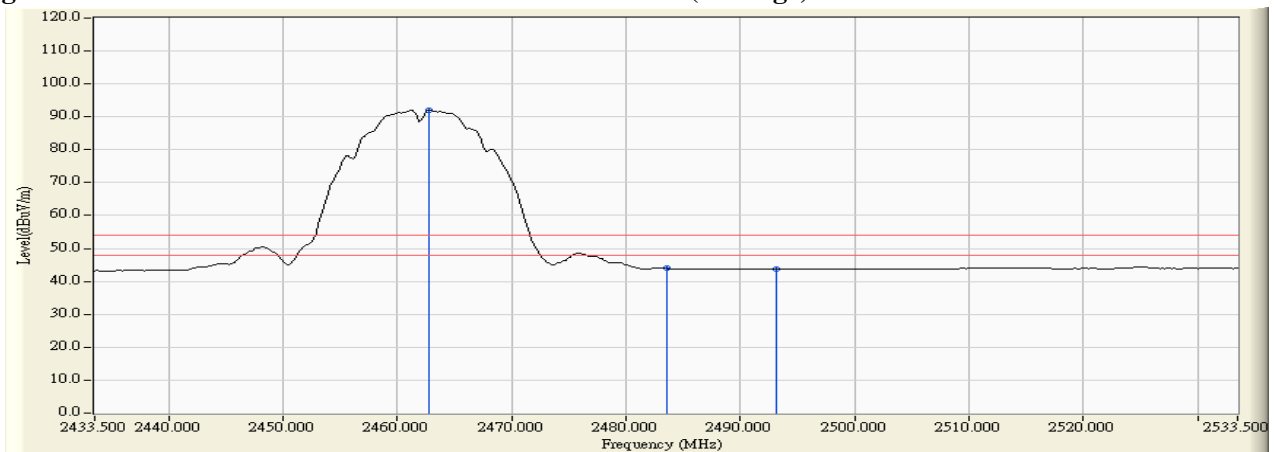

Figure Channel 11: Vertical (Average)



- Note: 1. All readings above 1GHz are performed with peak and/or average measurements as necessary.
 2. Peak measurements: RBW = 1MHz, VBW = 3 MHz, Sweep: Auto.
 3. Average measurements: RBW = 1MHz, VBW = 10 Hz, Sweep: Auto.
 4. “ * ”, means this data is the worst emission level.
 5. Measurement Level = Reading Level + Correct Factor.
 6. The average measurement was not performed when the peak measured data under the limit of average detection.

Product : AIS Class B Transponder
 Test Item : Band Edge Data
 Test Site : No.3 OATS
 Test Mode : Mode 2: Transmit (802.11g 6Mbps)

RF Radiated Measurement (Horizontal):

Channel No.	Frequency (MHz)	Correct Factor (dB)	Reading Level (dBuV)	Emission Level (dBuV/m)	Peak Limit (dBuV/m)	Average Limit (dBuV/m)	Result
01 (Peak)	2389.800	31.508	33.138	64.646	74.00	54.00	Pass
01 (Peak)	2390.000	31.509	31.711	63.220	74.00	54.00	Pass
01 (Peak)	2412.000	31.639	63.287	94.925	--	--	Pass
01(Average)	2389.800	31.508	16.043	47.551	74.00	54.00	Pass
01(Average)	2390.000	31.509	16.210	47.719	74.00	54.00	Pass
01(Average)	2413.400	31.649	51.443	83.092	--	--	Pass

Figure Channel 01: Horizontal (Peak)

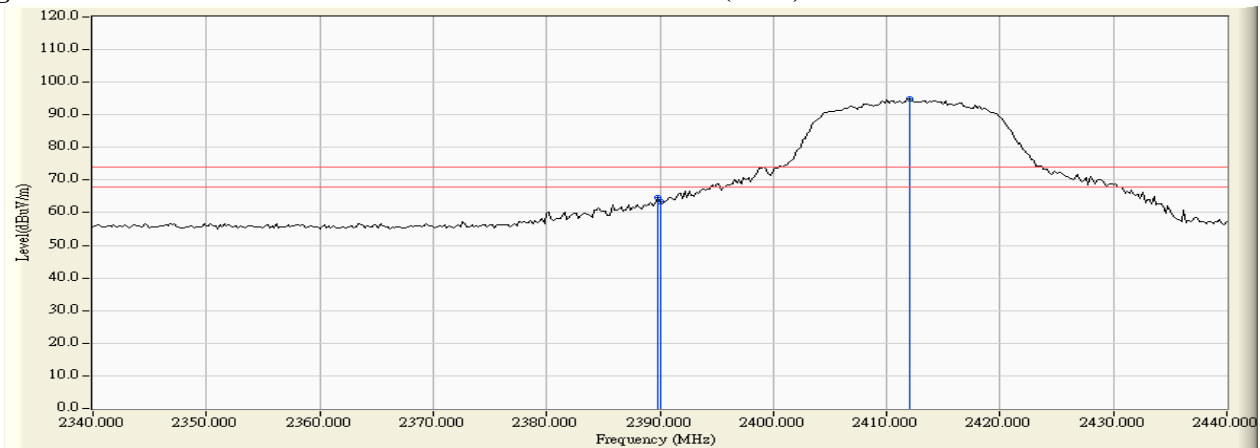
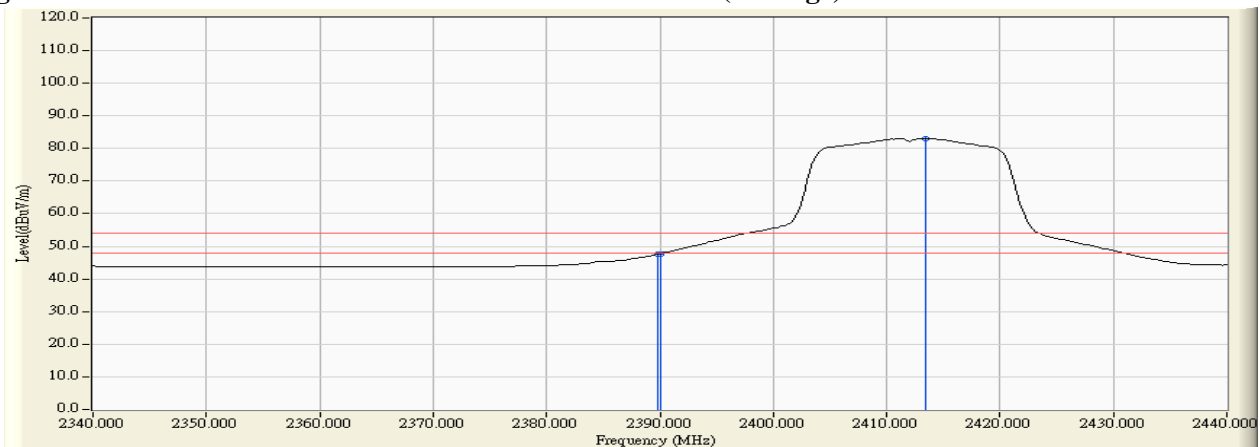

Figure Channel 01: Horizontal (Average)



- Note:1. All readings above 1GHz are performed with peak and/or average measurements as necessary.
 2. Peak measurements: RBW = 1MHz, VBW = 3 MHz, Sweep: Auto.
 3. Average measurements: RBW = 1MHz, VBW = 10 Hz, Sweep: Auto.
 4. “ * ”, means this data is the worst emission level.
 5. Measurement Level = Reading Level + Correct Factor.
 6. The average measurement was not performed when the peak measured data under the limit of average detection.

Product : AIS Class B Transponder
 Test Item : Band Edge Data
 Test Site : No.3 OATS
 Test Mode : Mode 2: Transmit (802.11g 6Mbps)

RF Radiated Measurement (Vertical):

Channel No.	Frequency (MHz)	Correct Factor (dB)	Reading Level (dBuV)	Emission Level (dBuV/m)	Peak Limit (dBuV/m)	Average Limit (dBuV/m)	Result
01 (Peak)	2389.800	30.916	37.749	68.665	74.00	54.00	Pass
01 (Peak)	2390.000	30.915	36.162	67.077	74.00	54.00	Pass
01 (Peak)	2412.000	30.950	68.800	99.749	--	--	Pass
01 (Average)	2389.800	30.916	19.372	50.288	74.00	54.00	Pass
01 (Average)	2390.000	30.915	19.637	50.552	74.00	54.00	Pass
01 (Average)	2413.400	30.959	56.471	87.430	--	--	Pass

Figure Channel 01: Vertical (Peak)

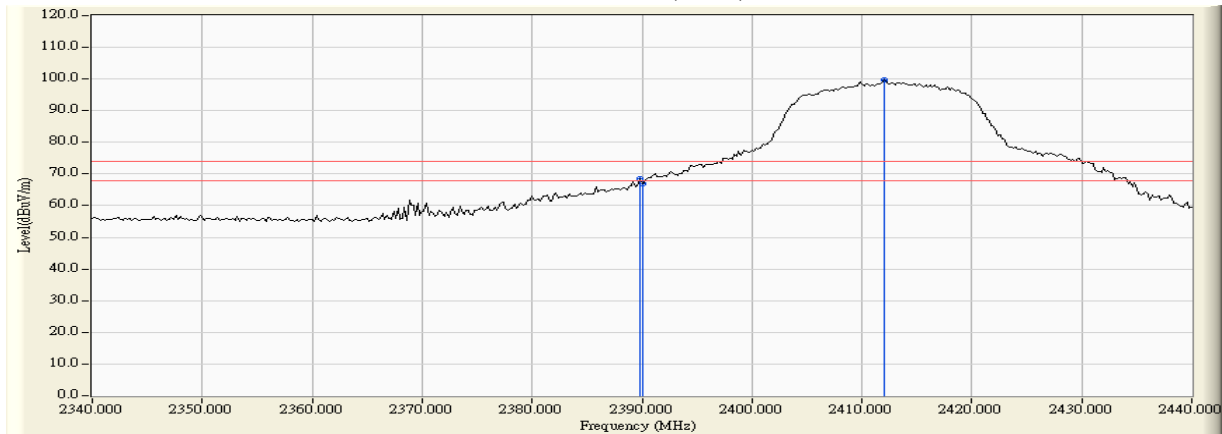
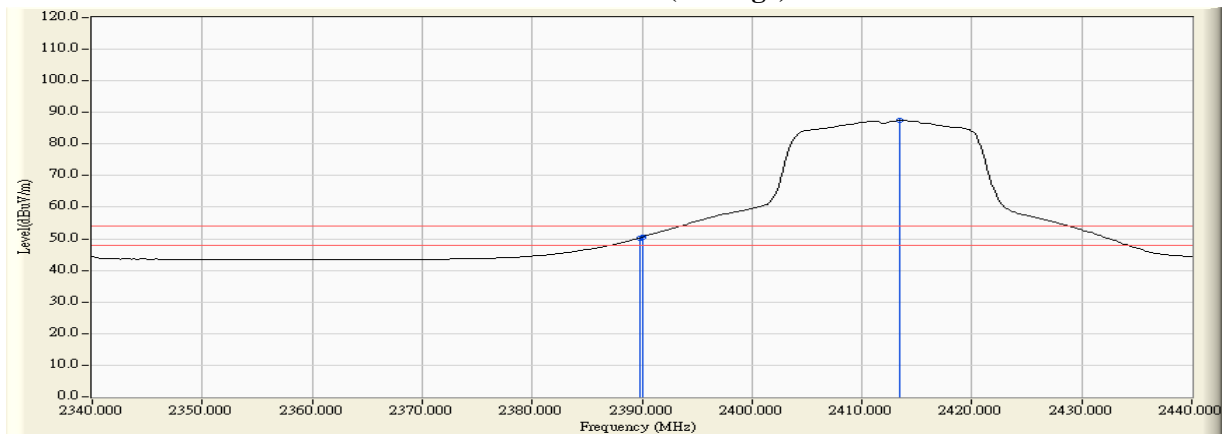

Figure Channel 01: Vertical (Average)



- Note:1. All readings above 1GHz are performed with peak and/or average measurements as necessary.
 2. Peak measurements: RBW = 1MHz, VBW = 3 MHz, Sweep: Auto.
 3. Average measurements: RBW = 1MHz, VBW = 10 Hz, Sweep: Auto.
 4. “ * ”, means this data is the worst emission level.
 5. Measurement Level = Reading Level + Correct Factor.
 6. The average measurement was not performed when the peak measured data under the limit of average detection.

Product : AIS Class B Transponder
 Test Item : Band Edge Data
 Test Site : No.3 OATS
 Test Mode : Mode 2: Transmit (802.11g 6Mbps)

RF Radiated Measurement (Horizontal):

Channel No.	Frequency (MHz)	Correct Factor (dB)	Reading Level (dBuV)	Emission Level (dBuV/m)	Peak Limit (dBuV/m)	Average Limit (dBuV/m)	Result
11 (Peak)	2461.900	32.018	60.920	92.939	--	--	Pass
11 (Peak)	2483.500	32.182	26.084	58.266	74.00	54.00	Pass
11 (Peak)	2484.700	32.192	26.822	59.013	74.00	54.00	Pass
11 (Average)	2463.300	32.029	48.359	80.388	--	--	Pass
11 (Average)	2483.500	32.182	13.069	45.251	74.00	54.00	Pass
11 (Average)	2484.700	32.192	12.757	44.948	74.00	54.00	Pass

Figure Channel 11: Horizontal (Peak)

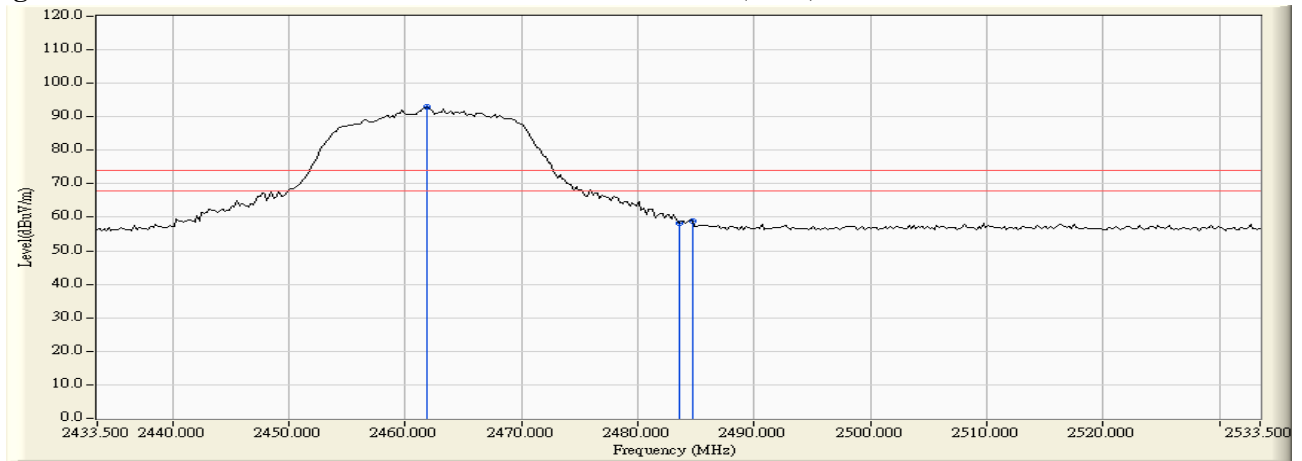
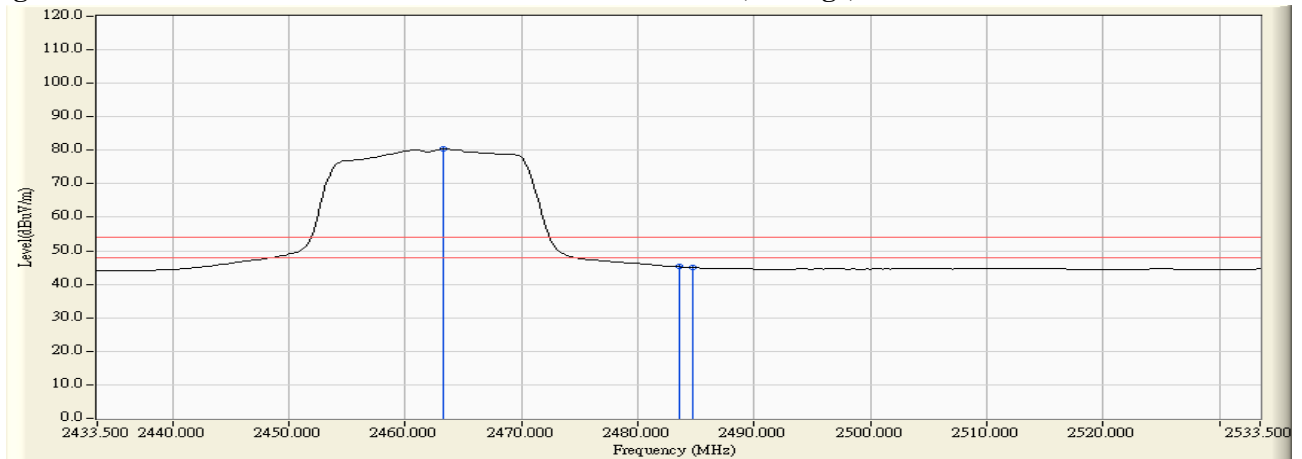

Figure Channel 11: Horizontal (Average)



- Note: 1. All readings above 1GHz are performed with peak and/or average measurements as necessary.
 2. Peak measurements: RBW = 1MHz, VBW = 3 MHz, Sweep: Auto.
 3. Average measurements: RBW = 1MHz, VBW = 10 Hz, Sweep: Auto.
 4. “ * ”, means this data is the worst emission level.
 5. Measurement Level = Reading Level + Correct Factor.
 6. The average measurement was not performed when the peak measured data under the limit of average detection.

Product : AIS Class B Transponder
 Test Item : Band Edge Data
 Test Site : No.3 OATS
 Test Mode : Mode 2: Transmit (802.11g 6Mbps)

RF Radiated Measurement (Vertical):

Channel No.	Frequency (MHz)	Correct Factor (dB)	Reading Level (dBuV)	Emission Level (dBuV/m)	Peak Limit (dBuV/m)	Average Limit (dBuV/m)	Result
11 (Peak)	2461.900	31.289	66.043	97.333	--	--	Pass
11 (Peak)	2483.500	31.435	30.718	62.153	74.00	54.00	Pass
11 (Average)	2463.100	31.298	53.364	84.662	--	--	Pass
11 (Average)	2483.500	31.435	13.821	45.256	74.00	54.00	Pass

Figure Channel 11: Vertical (Peak)

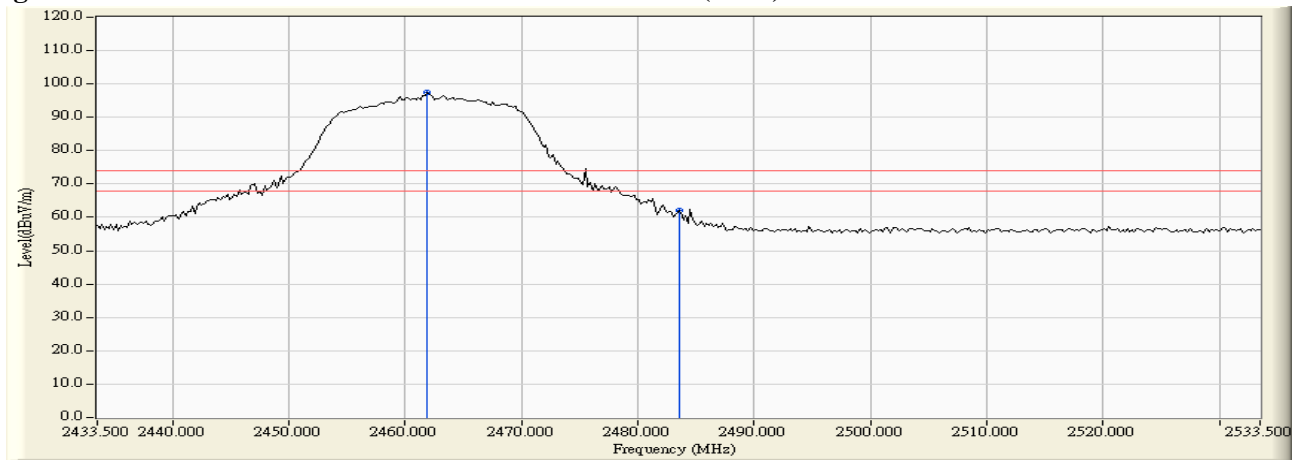
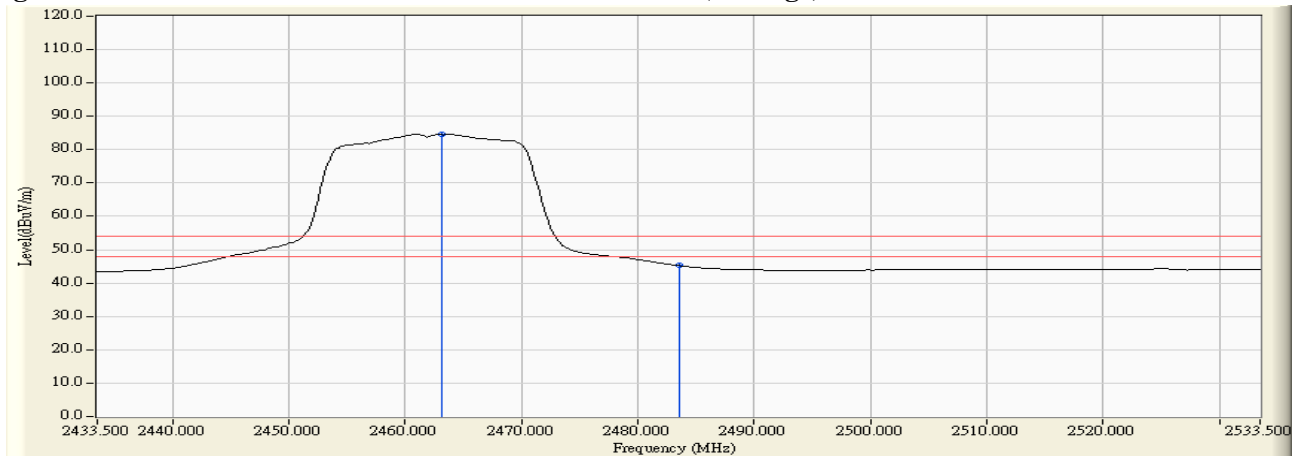

Figure Channel 11: Vertical (Average)



- Note: 1. All readings above 1GHz are performed with peak and/or average measurements as necessary.
 2. Peak measurements: RBW = 1MHz, VBW = 3 MHz, Sweep: Auto.
 3. Average measurements: RBW = 1MHz, VBW = 10 Hz, Sweep: Auto.
 4. “ * ”, means this data is the worst emission level.
 5. Measurement Level = Reading Level + Correct Factor.
 6. The average measurement was not performed when the peak measured data under the limit of average detection.

Product : AIS Class B Transponder
 Test Item : Band Edge Data
 Test Site : No.3 OATS
 Test Mode : Mode 3: Transmit (802.11n MCS0 7.2Mbps 20M-BW)

RF Radiated Measurement (Horizontal):

Channel No.	Frequency (MHz)	Correct Factor (dB)	Reading Level (dBuV)	Emission Level (dBuV/m)	Peak Limit (dBuV/m)	Average Limit (dBuV/m)	Result
01 (Peak)	2390.000	31.509	31.009	62.518	74.00	54.00	Pass
01 (Peak)	2410.600	31.628	62.432	94.060	--	--	Pass
01 (Average)	2390.000	31.509	15.755	47.264	74.00	54.00	Pass
01 (Average)	2413.600	31.650	50.745	82.395	--	--	Pass

Figure Channel 01: Horizontal (Peak)

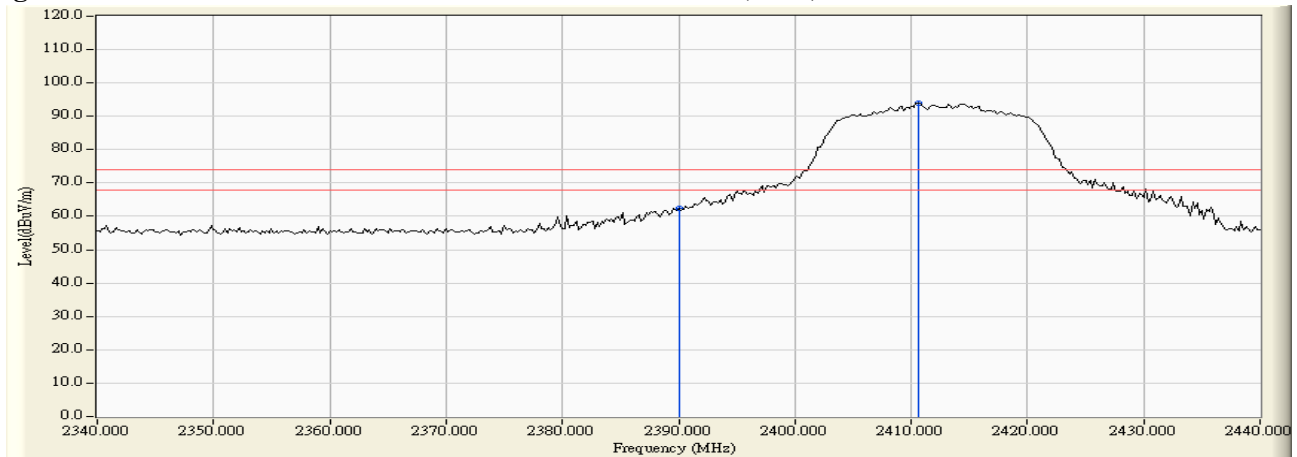
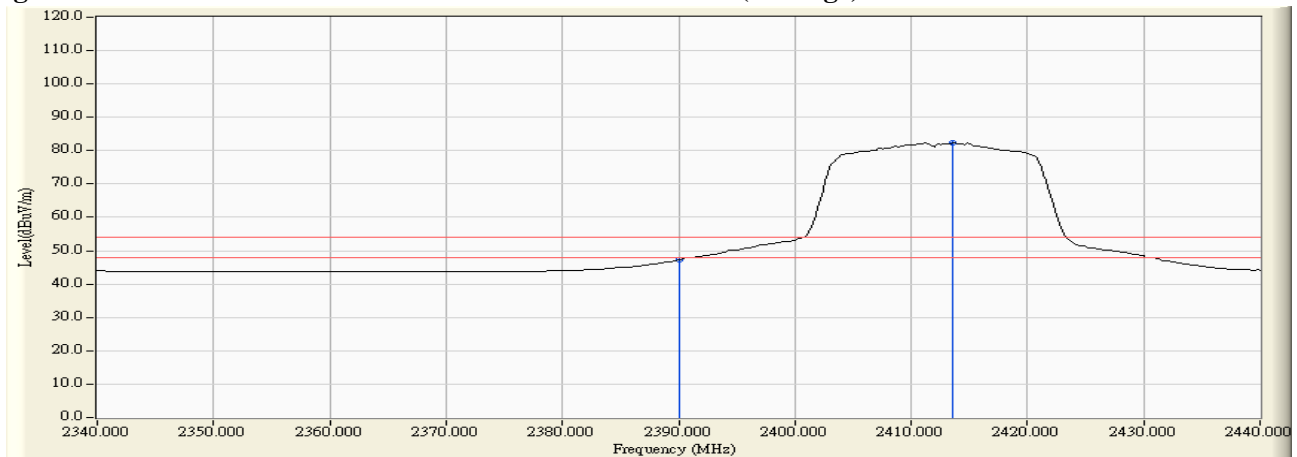

Figure Channel 01: Horizontal (Average)



- Note: 1. All readings above 1GHz are performed with peak and/or average measurements as necessary.
 2. Peak measurements: RBW = 1MHz, VBW = 3 MHz, Sweep: Auto.
 3. Average measurements: RBW = 1MHz, VBW = 10 Hz, Sweep: Auto.
 4. “ * ”, means this data is the worst emission level.
 5. Measurement Level = Reading Level + Correct Factor.
 6. The average measurement was not performed when the peak measured data under the limit of average detection.

Product : AIS Class B Transponder
 Test Item : Band Edge Data
 Test Site : No.3 OATS
 Test Mode : Mode 3: Transmit (802.11n MCS0 7.2Mbps 20M-BW)

RF Radiated Measurement (Vertical):

Channel No.	Frequency (MHz)	Correct Factor (dB)	Reading Level (dBuV)	Emission Level (dBuV/m)	Peak Limit (dBuV/m)	Average Limit (dBuV/m)	Result
01 (Peak)	2390.000	30.915	37.519	68.434	74.00	54.00	Pass
01 (Peak)	2413.000	30.956	68.730	99.686	--	--	Pass
01 (Average)	2390.000	30.915	19.792	50.707	74.00	54.00	Pass
01 (Average)	2414.000	30.963	57.061	88.024	--	--	Pass

Figure Channel 01: Vertical (Peak)

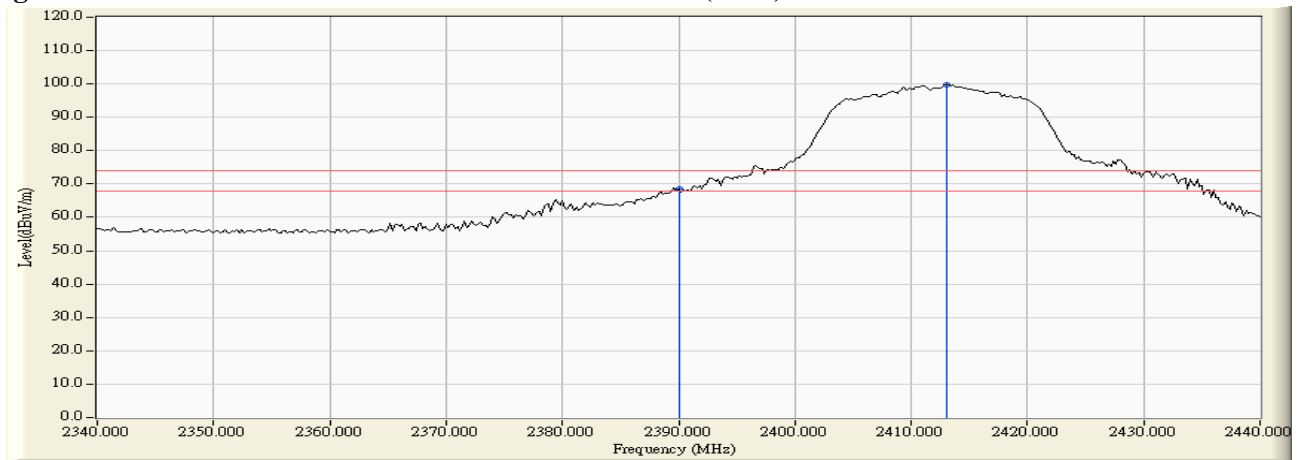
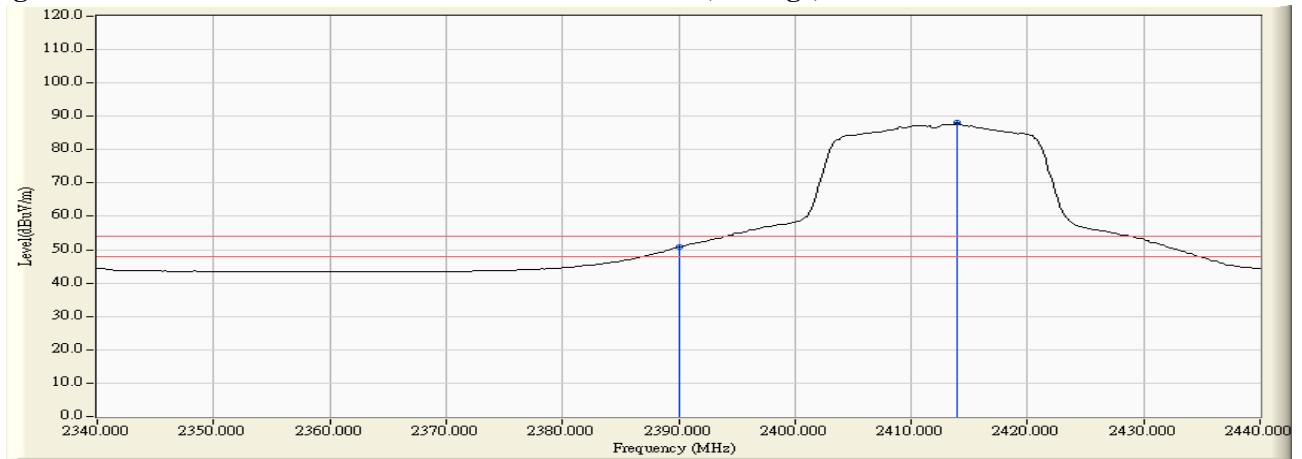

Figure Channel 01: Vertical (Average)



- Note:1. All readings above 1GHz are performed with peak and/or average measurements as necessary.
 2. Peak measurements: RBW = 1MHz, VBW = 3 MHz, Sweep: Auto.
 3. Average measurements: RBW = 1MHz, VBW = 10 Hz, Sweep: Auto.
 4. “ * ”, means this data is the worst emission level.
 5. Measurement Level = Reading Level + Correct Factor.
 6. The average measurement was not performed when the peak measured data under the limit of average detection.

Product : AIS Class B Transponder
 Test Item : Band Edge Data
 Test Site : No.3 OATS
 Test Mode : Mode 3: Transmit (802.11n MCS0 7.2Mbps 20M-BW)

RF Radiated Measurement (Horizontal):

Channel No.	Frequency (MHz)	Correct Factor (dB)	Reading Level (dBuV)	Emission Level (dBuV/m)	Peak Limit (dBuV/m)	Average Limit (dBuV/m)	Result
11 (Peak)	2463.900	32.033	59.800	91.834	--	--	Pass
11 (Peak)	2483.500	32.182	25.423	57.605	74.00	54.00	Pass
11 (Average)	2463.100	32.028	47.417	79.445	--	--	Pass
11 (Average)	2483.500	32.182	12.726	44.908	74.00	54.00	Pass

Figure Channel 11: Horizontal (Peak)

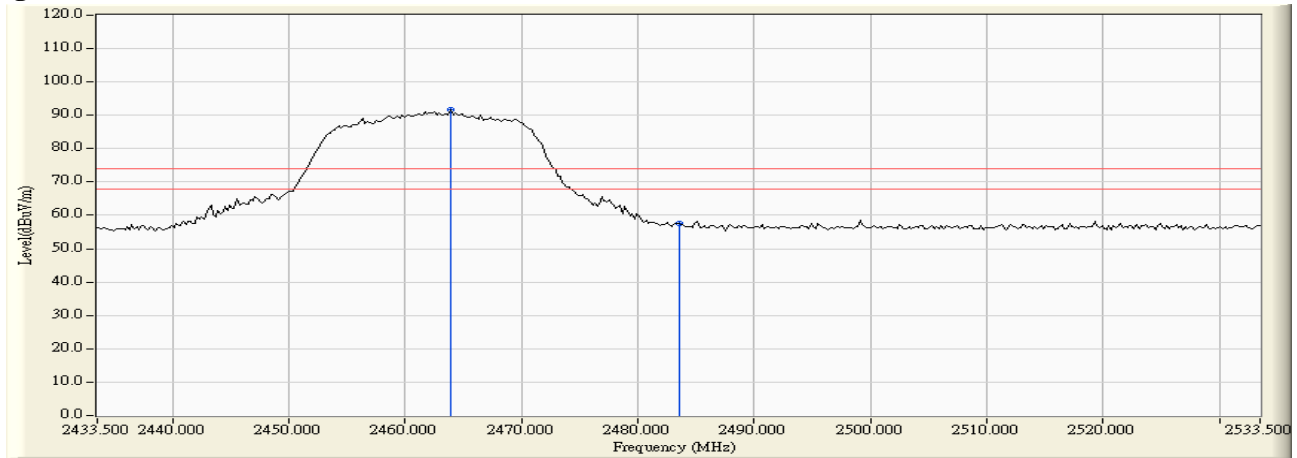
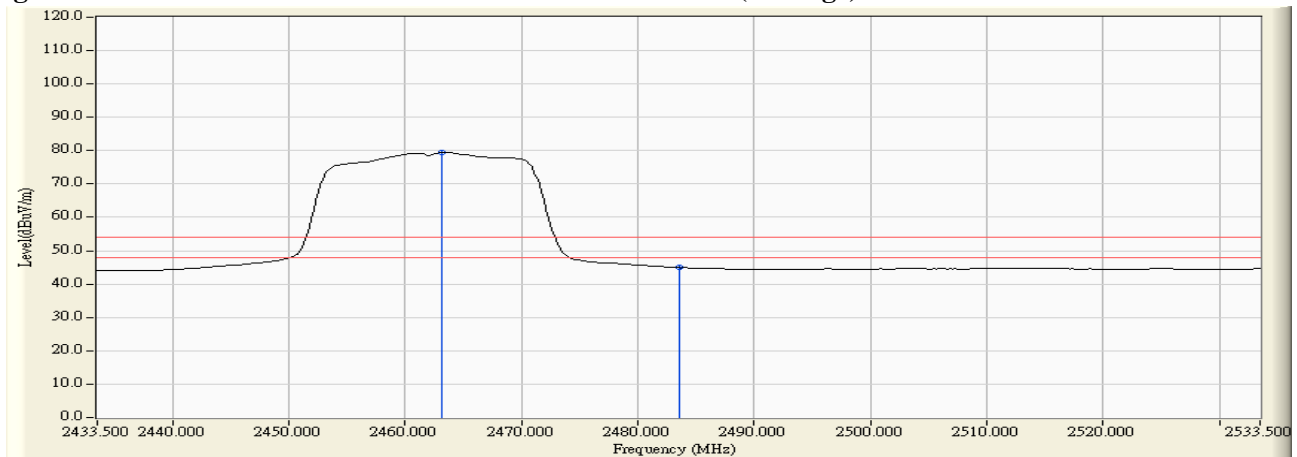

Figure Channel 11: Horizontal (Average)



- Note:1. All readings above 1GHz are performed with peak and/or average measurements as necessary.
 2. Peak measurements: RBW = 1MHz, VBW = 3 MHz, Sweep: Auto.
 3. Average measurements: RBW = 1MHz, VBW = 10 Hz, Sweep: Auto.
 4. “ * ”, means this data is the worst emission level.
 5. Measurement Level = Reading Level + Correct Factor.
 6. The average measurement was not performed when the peak measured data under the limit of average detection.

Product : AIS Class B Transponder
 Test Item : Band Edge Data
 Test Site : No.3 OATS
 Test Mode : Mode 3: Transmit (802.11n MCS0 7.2Mbps 20M-BW)

RF Radiated Measurement (Vertical):

Channel No.	Frequency (MHz)	Correct Factor (dB)	Reading Level (dBuV)	Emission Level (dBuV/m)	Peak Limit (dBuV/m)	Average Limit (dBuV/m)	Result
11 (Peak)	2460.500	31.280	64.260	95.540	--	--	Pass
11 (Peak)	2483.500	31.435	27.158	58.593	74.00	54.00	Pass
11 (Average)	2463.300	31.299	51.497	82.796	--	--	Pass
11 (Average)	2483.500	31.435	13.372	44.807	74.00	54.00	Pass

Figure Channel 11: Vertical (Peak)

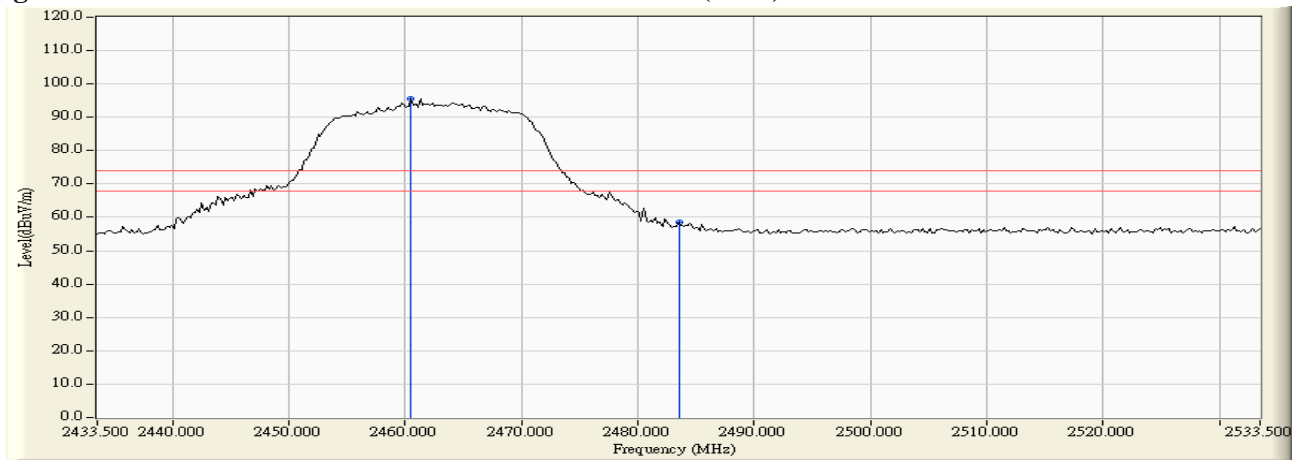
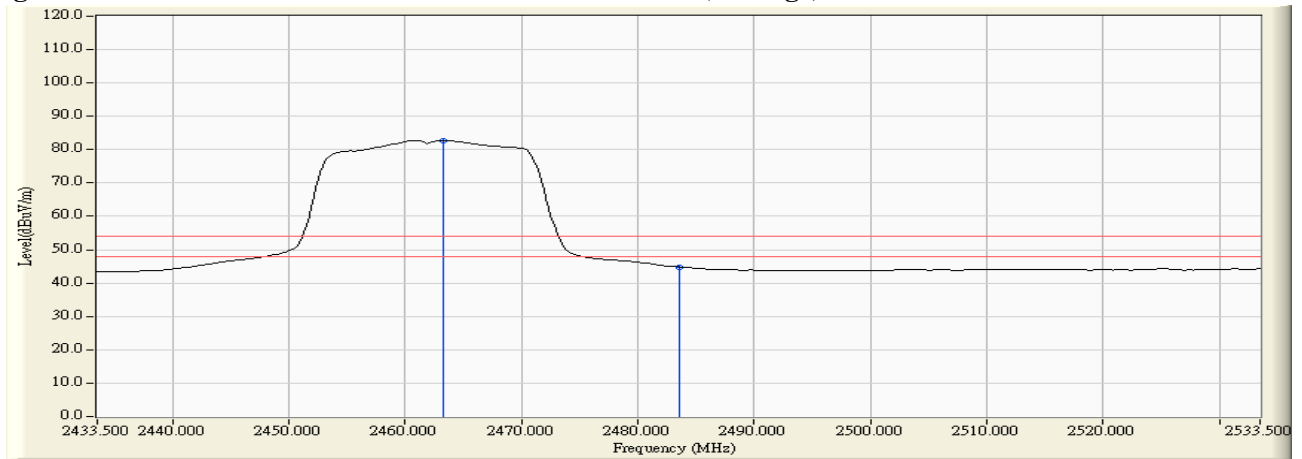

Figure Channel 11: Vertical (Average)



- Note:1. All readings above 1GHz are performed with peak and/or average measurements as necessary.
 2. Peak measurements: RBW = 1MHz, VBW = 3 MHz, Sweep: Auto.
 3. Average measurements: RBW = 1MHz, VBW = 10 Hz, Sweep: Auto.
 4. “ * ”, means this data is the worst emission level.
 5. Measurement Level = Reading Level + Correct Factor.
 6. The average measurement was not performed when the peak measured data under the limit of average detection.

7. Occupied Bandwidth

7.1. Test Equipment

	Equipment	Manufacturer	Model No./Serial No.	Last Cal.
	Spectrum Analyzer	R&S	FSP40 / 100170	Jun, 2013
	Spectrum Analyzer	Agilent	E4407B / US39440758	Jun, 2013
X	Spectrum Analyzer	Agilent	N9010A / MY48030495	Apr., 2013

Note:

1. All equipments are calibrated with traceable calibrations. Each calibration is traceable to the national or international standards.
2. The test instruments marked with “X” are used to measure the final test results.

7.2. Test Setup

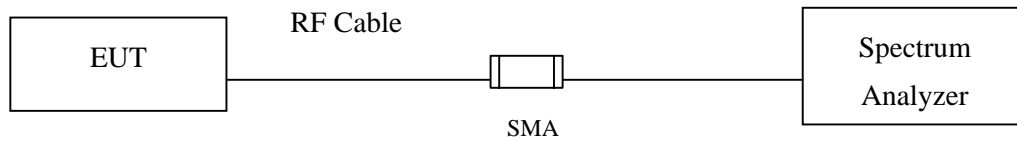

7.3. Limits

The minimum bandwidth shall be at least 500 kHz.

7.4. Test Procedure

The EUT was setup according to ANSI C63.10: 2009; tested according to DTS test procedure of KDB558074 for compliance to FCC 47CFR 15.247 requirements.

7.5. Uncertainty

± 150Hz

7.6. Test Result of Occupied Bandwidth

Product : AIS Class B Transponder
 Test Item : Occupied Bandwidth Data
 Test Site : No.3 OATS
 Test Mode : Mode 1: Transmit (802.11b 1Mbps) (2412MHz)

Channel No.	Frequency (MHz)	Measurement Level (kHz)	Required Limit (kHz)	Result
1	2412	8150	>500	Pass

Figure Channel 1:

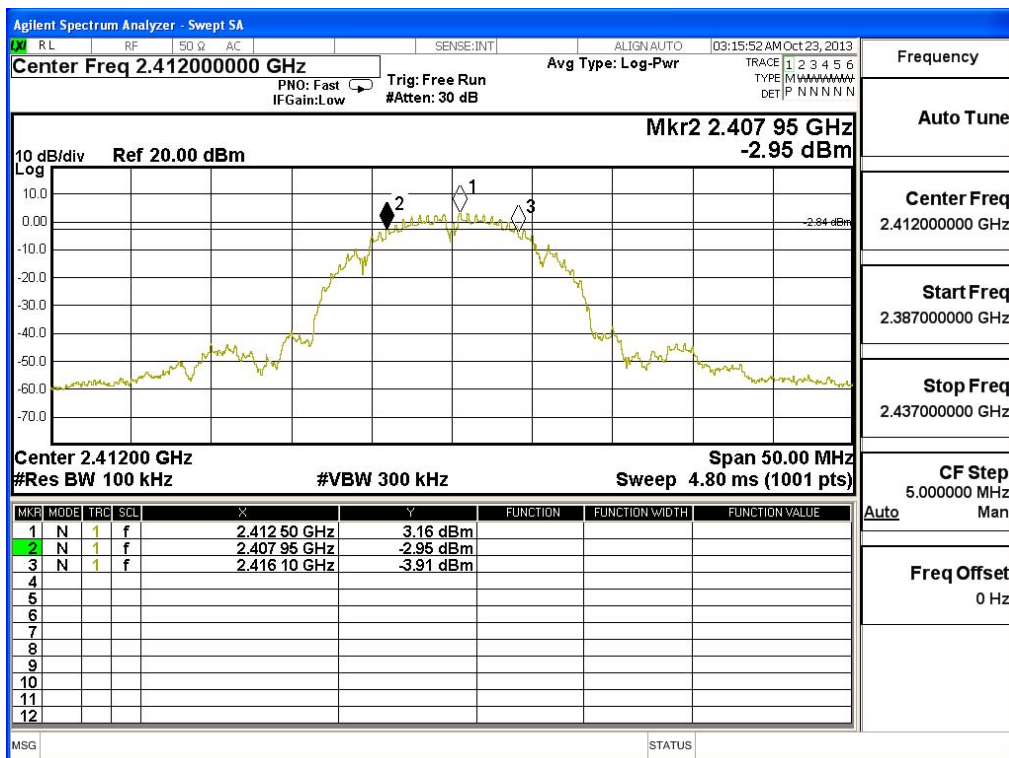

Product : AIS Class B Transponder
 Test Item : Occupied Bandwidth Data
 Test Site : No.3 OATS
 Test Mode : Mode 1: Transmit (802.11b 1Mbps) (2437MHz)

Channel No.	Frequency (MHz)	Measurement Level (kHz)	Required Limit (kHz)	Result
6	2437	8200	>500	Pass

Figure Channel 6:

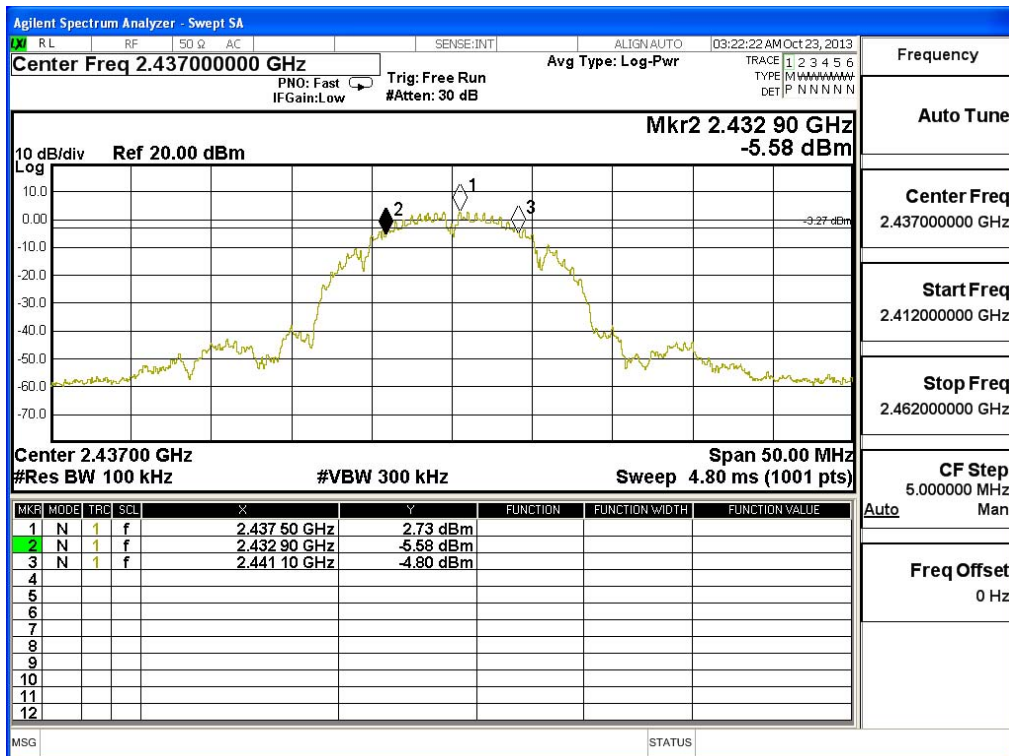

Product : AIS Class B Transponder
 Test Item : Occupied Bandwidth Data
 Test Site : No.3 OATS
 Test Mode : Mode 1: Transmit (802.11b 1Mbps) (2462MHz)

Channel No.	Frequency (MHz)	Measurement Level (kHz)	Required Limit (kHz)	Result
11	2462	8200	>500	Pass

Figure Channel 11:

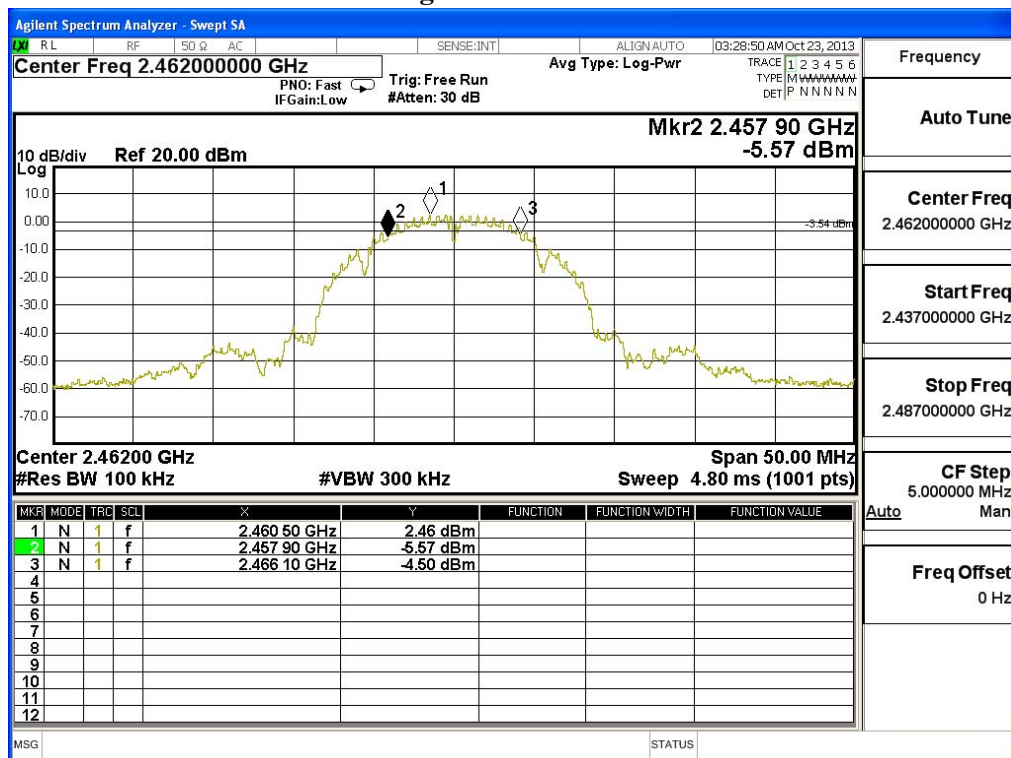

Product : AIS Class B Transponder
 Test Item : Occupied Bandwidth Data
 Test Site : No.3 OATS
 Test Mode : Mode 2: Transmit (802.11g 6Mbps) (2412MHz)

Channel No.	Frequency (MHz)	Measurement Level (kHz)	Required Limit (kHz)	Result
1	2412	15250	>500	Pass

Figure Channel 1:

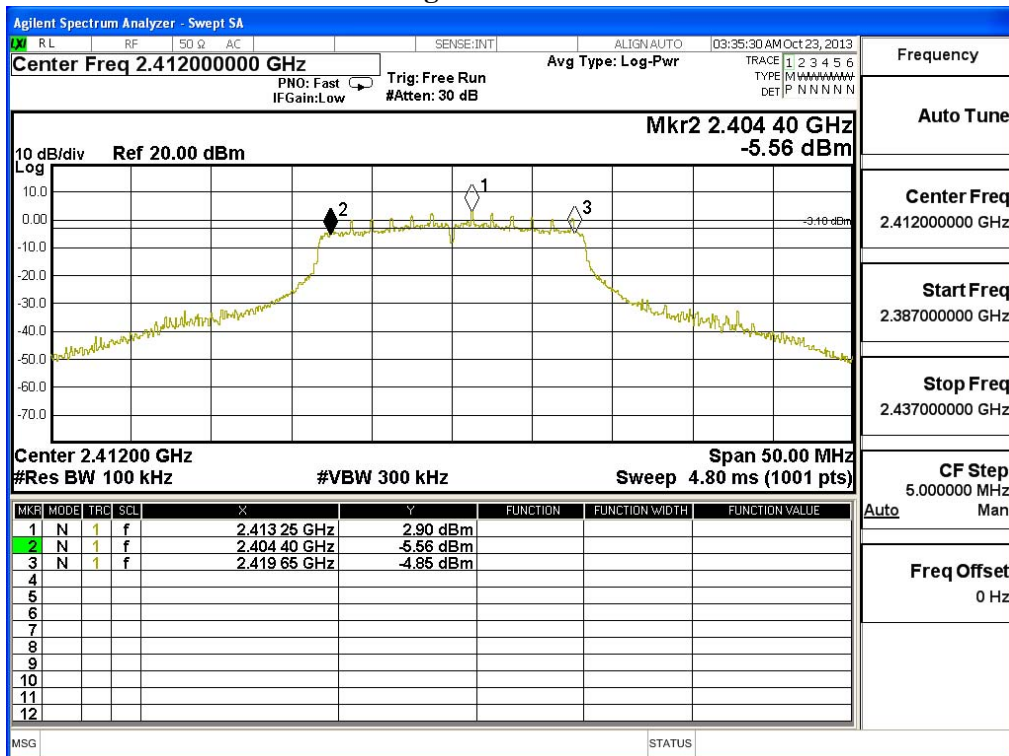

Product : AIS Class B Transponder
 Test Item : Occupied Bandwidth Data
 Test Site : No.3 OATS
 Test Mode : Mode 2: Transmit (802.11g 6Mbps) (2437MHz)

Channel No.	Frequency (MHz)	Measurement Level (kHz)	Required Limit (kHz)	Result
6	2437	15250	>500	Pass

Figure Channel 6:

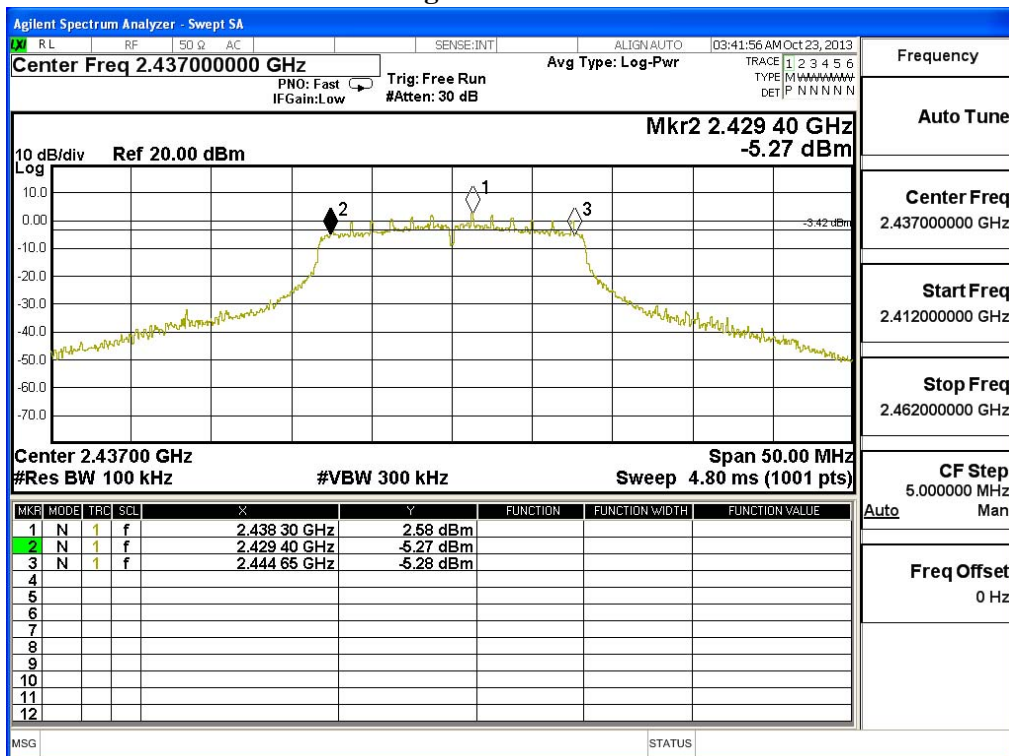

Product : AIS Class B Transponder
 Test Item : Occupied Bandwidth Data
 Test Site : No.3 OATS
 Test Mode : Mode 2: Transmit (802.11g 6Mbps) (2462MHz)

Channel No.	Frequency (MHz)	Measurement Level (kHz)	Required Limit (kHz)	Result
11	2462	15250	>500	Pass

Figure Channel 11:

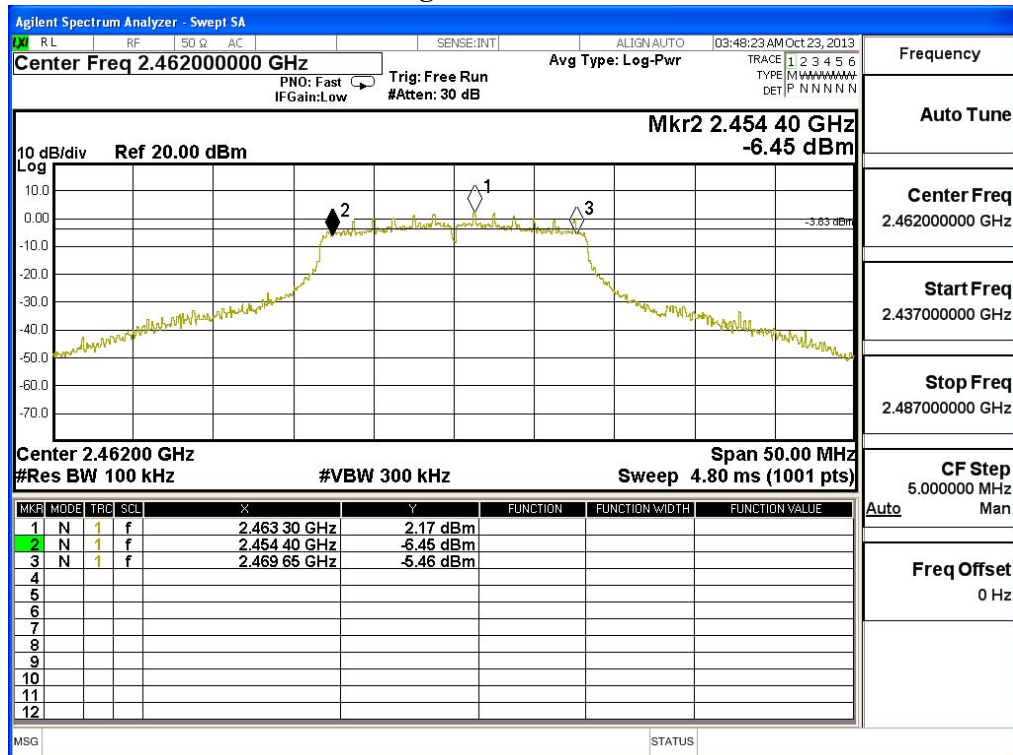

Product : AIS Class B Transponder
 Test Item : Occupied Bandwidth Data
 Test Site : No.3 OATS
 Test Mode : Mode 3: Transmit (802.11n MCS0 7.2Mbps 20M-BW) (2412MHz)

Channel No.	Frequency (MHz)	Measurement Level (kHz)	Required Limit (kHz)	Result
1	2412	15150	>500	Pass

Figure Channel 1:

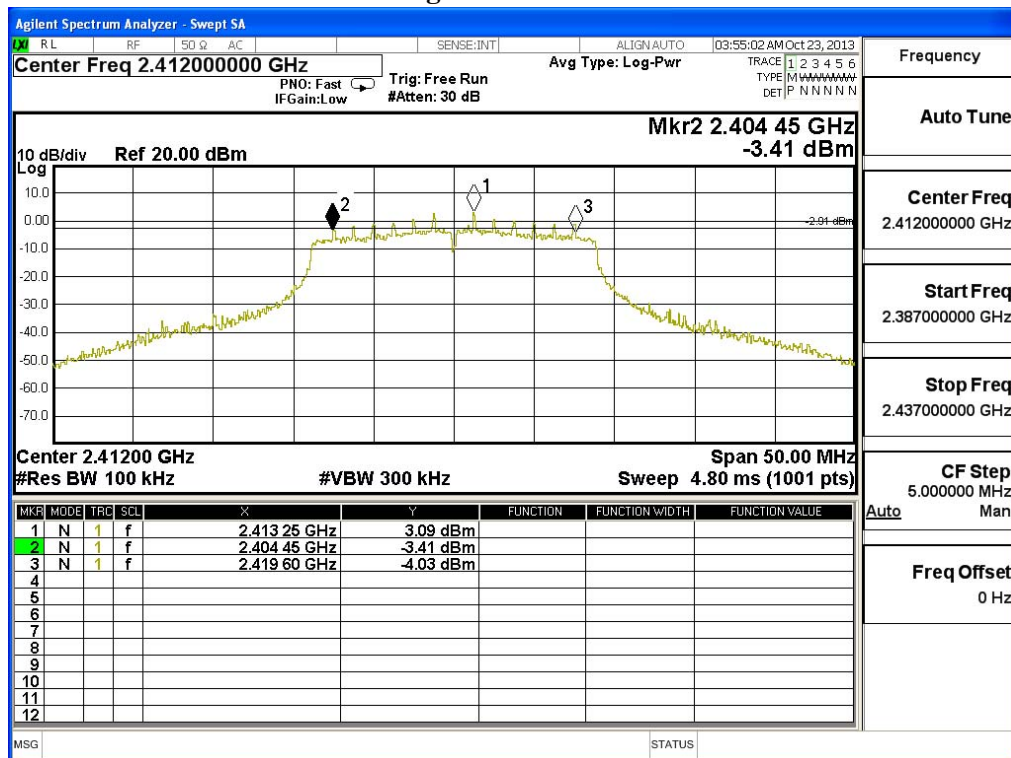

Product : AIS Class B Transponder
 Test Item : Occupied Bandwidth Data
 Test Site : No.3 OATS
 Test Mode : Mode 3: Transmit (802.11n MCS0 7.2Mbps 20M-BW) (2437MHz)

Channel No.	Frequency (MHz)	Measurement Level (kHz)	Required Limit (kHz)	Result
6	2437	15250	>500	Pass

Figure Channel 6:

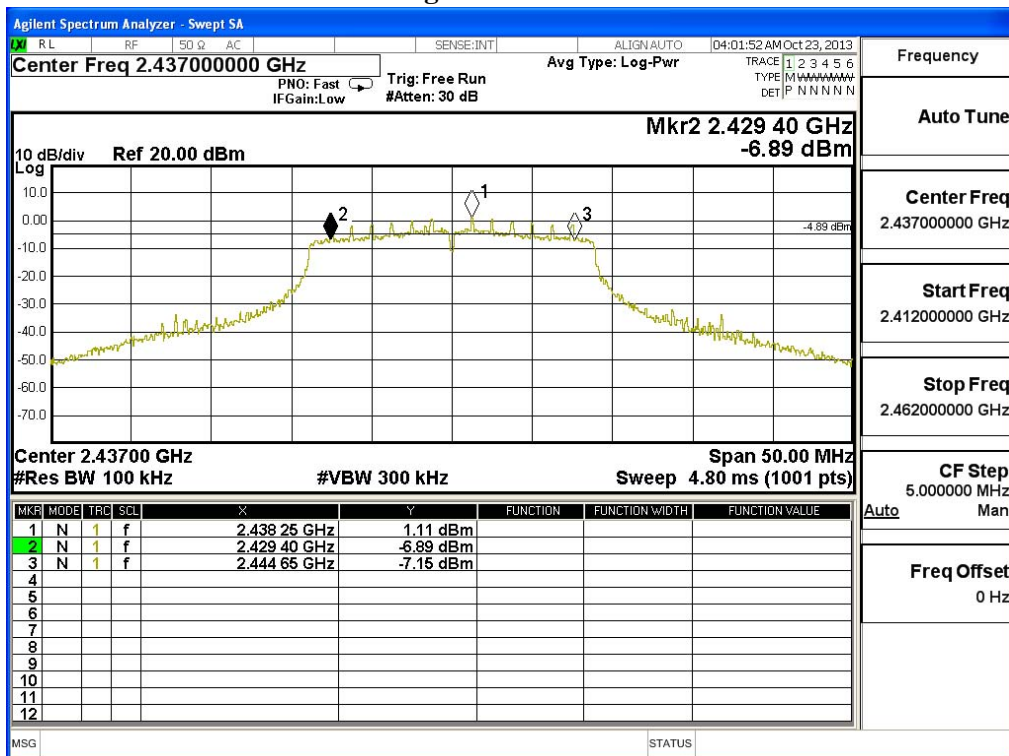

Product : AIS Class B Transponder
 Test Item : Occupied Bandwidth Data
 Test Site : No.3 OATS
 Test Mode : Mode 3: Transmit (802.11n MCS0 7.2Mbps 20M-BW) (2462MHz)

Channel No.	Frequency (MHz)	Measurement Level (kHz)	Required Limit (kHz)	Result
11	2462	15200	>500	Pass

Figure Channel 11:

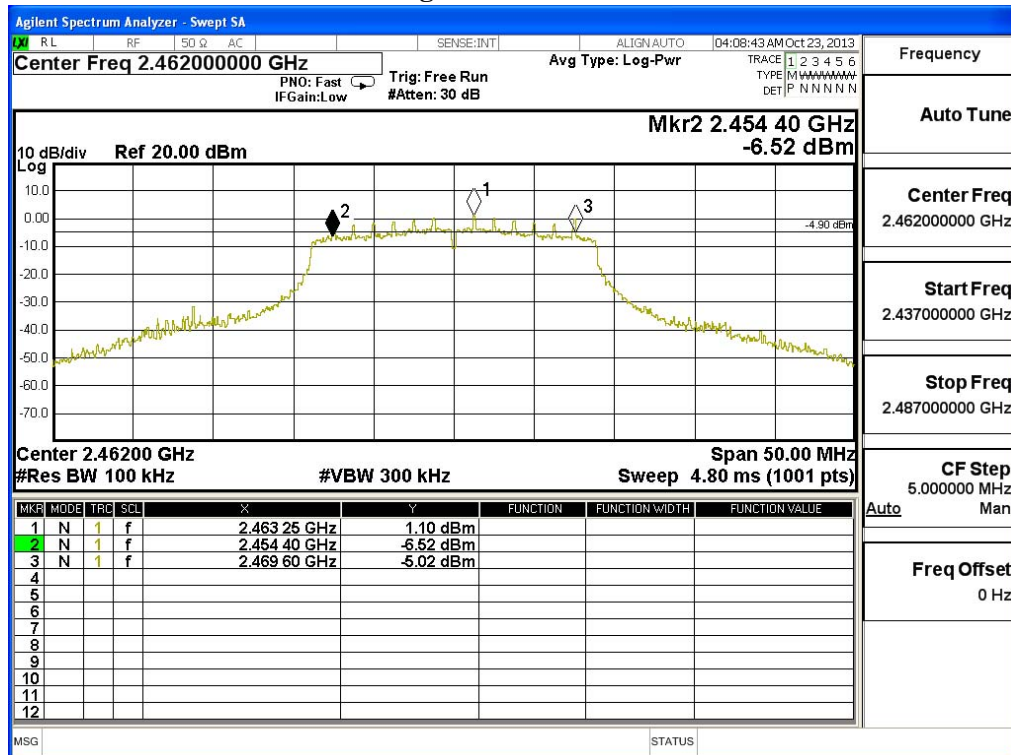

8. Power Density

8.1. Test Equipment

	Equipment	Manufacturer	Model No./Serial No.	Last Cal.
	Spectrum Analyzer	R&S	FSP40 / 100170	Jun, 2013
	Spectrum Analyzer	Agilent	E4407B / US39440758	Jun, 2013
X	Spectrum Analyzer	Agilent	N9010A / MY48030495	Apr., 2013

Note:

1. All equipments are calibrated with traceable calibrations. Each calibration is traceable to the national or international standards.
2. The test instruments marked with “X” are used to measure the final test results.

8.2. Test Setup

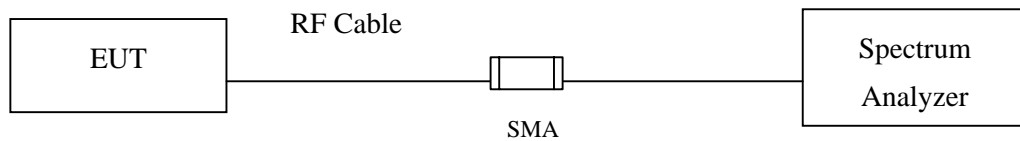

8.3. Limits

The transmitted power density averaged over any 1 second interval shall not be greater +8dBm in any 3kHz bandwidth.

8.4. Test Procedure

The EUT was setup according to ANSI C63.10, 2009; tested according to DTS test procedure of KDB 558074 for compliance to FCC 47CFR 15.247 requirements.

The maximum power spectral density using KDB 558074 section 10.2 PKPSD (peak PSD) method.

8.5. Uncertainty

± 1.27 dB

8.6. Test Result of Power Density

Product : AIS Class B Transponder
 Test Item : Power Density Data
 Test Site : No.3 OATS
 Test Mode : Mode 1: Transmit (802.11b 1Mbps) (2412MHz)

Channel No.	Frequency (MHz)	Measure Level (dBm)	Limit (dBm)	Result
1	2412	3.110	< 8dBm	Pass

Figure Channel 1:

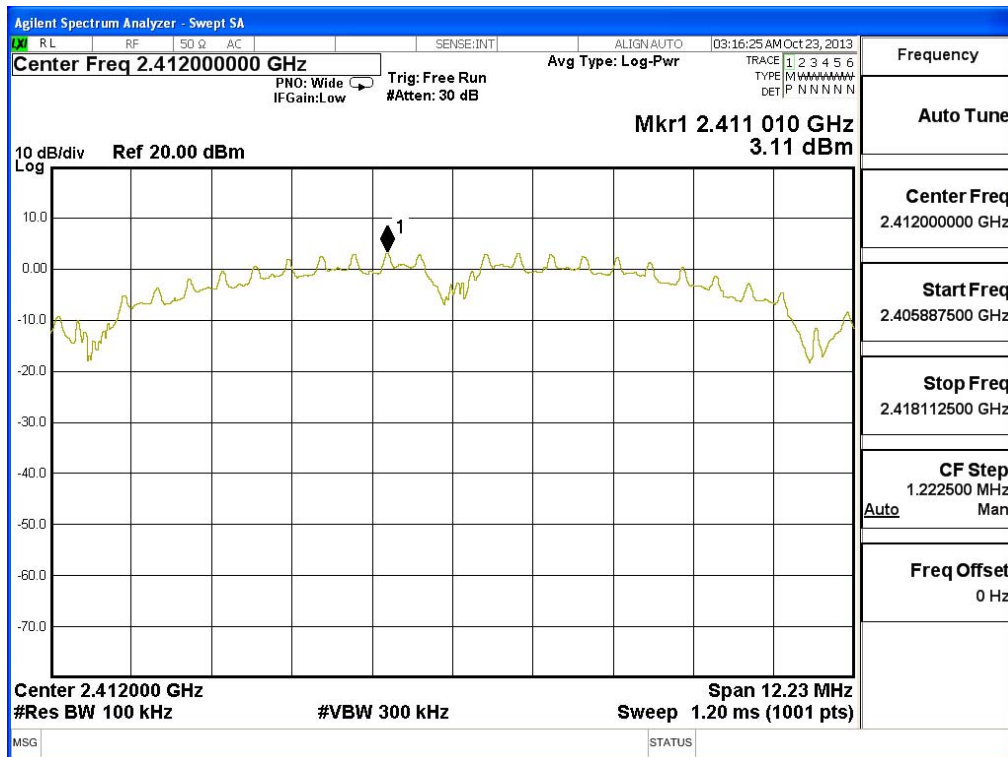

Product : AIS Class B Transponder
 Test Item : Power Density Data
 Test Site : No.3OATS
 Test Mode : Mode 1: Transmit (802.11b 1Mbps) (2437MHz)

Channel No.	Frequency (MHz)	Measurement Level (dBm)	Required Limit (dBm)	Result
6	2437	2.650	< 8dBm	Pass

Figure Channel 6:

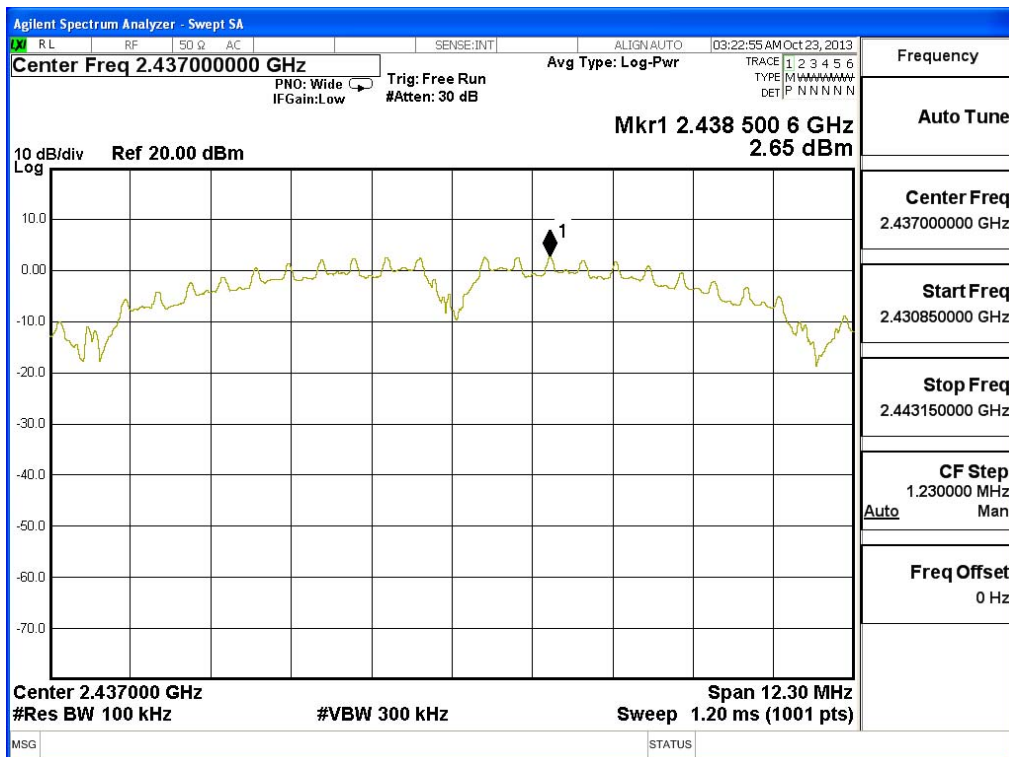

Product : AIS Class B Transponder
 Test Item : Power Density Data
 Test Site : No.3 OATS
 Test Mode : Mode 1: Transmit (802.11b 1Mbps) (2462MHz)

Channel No.	Frequency (MHz)	Measurement Level (dBm)	Required Limit (dBm)	Result
11	2462	2.730	< 8dBm	Pass

Figure Channel 11:

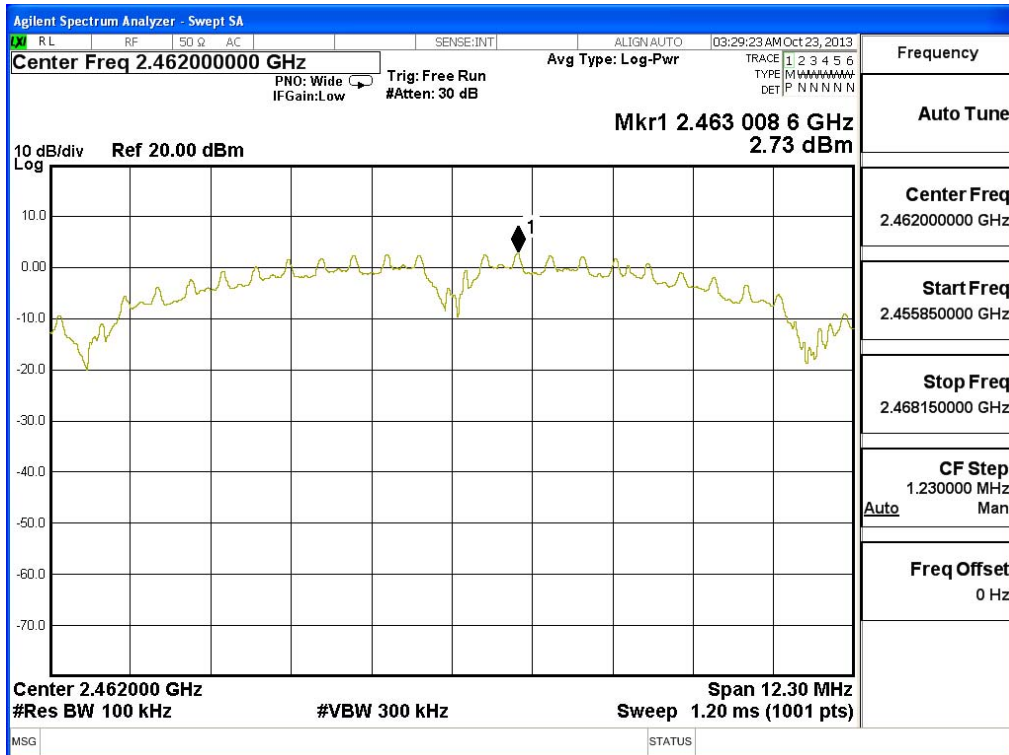

Product : AIS Class B Transponder
 Test Item : Power Density Data
 Test Site : No.3 OATS
 Test Mode : Mode 2: Transmit (802.11g 6Mbps) (2412MHz)

Channel No.	Frequency (MHz)	Measure Level (dBm)	Limit (dBm)	Result
1	2412	3.220	< 8dBm	Pass

Figure Channel 1:

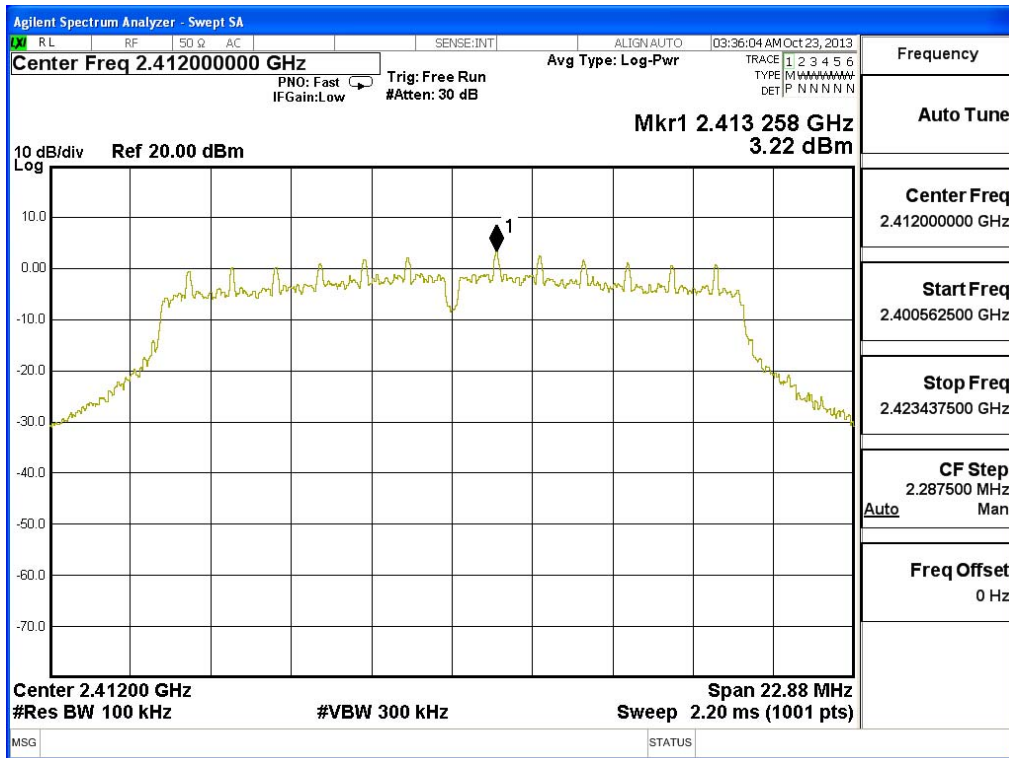

Product : AIS Class B Transponder
 Test Item : Power Density Data
 Test Site : No.3OATS
 Test Mode : Mode 2: Transmit (802.11g 6Mbps) (2437MHz)

Channel No.	Frequency (MHz)	Measurement Level (dBm)	Required Limit (dBm)	Result
6	2437	2.610	< 8dBm	Pass

Figure Channel 6:

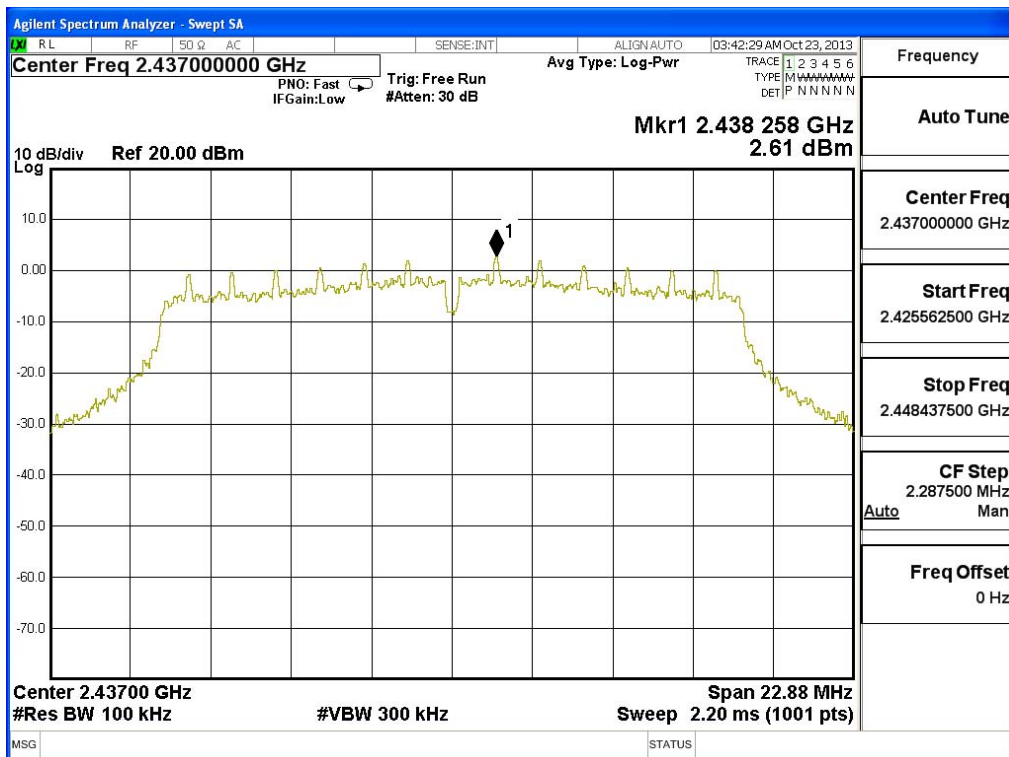

Product : AIS Class B Transponder
 Test Item : Power Density Data
 Test Site : No.3 OATS
 Test Mode : Mode 2: Transmit (802.11g 6Mbps) (2462MHz)

Channel No.	Frequency (MHz)	Measurement Level (dBm)	Required Limit (dBm)	Result
11	2462	2.380	< 8dBm	Pass

Figure Channel 11:

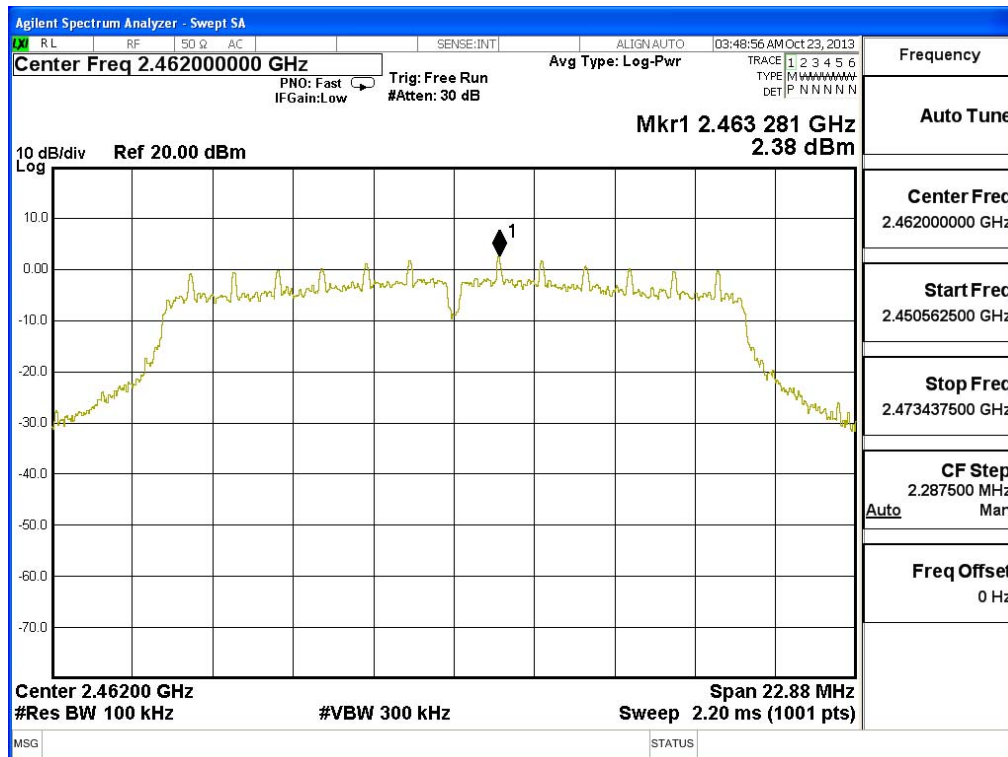

Product : AIS Class B Transponder
 Test Item : Power Density Data
 Test Site : No.3 OATS
 Test Mode : Mode 3: Transmit (802.11n MCS0 7.2Mbps 20M-BW) (2412MHz)

Channel No.	Frequency (MHz)	Measure Level (dBm)	Limit (dBm)	Result
1	2412	1.510	< 8dBm	Pass

Figure Channel 1:

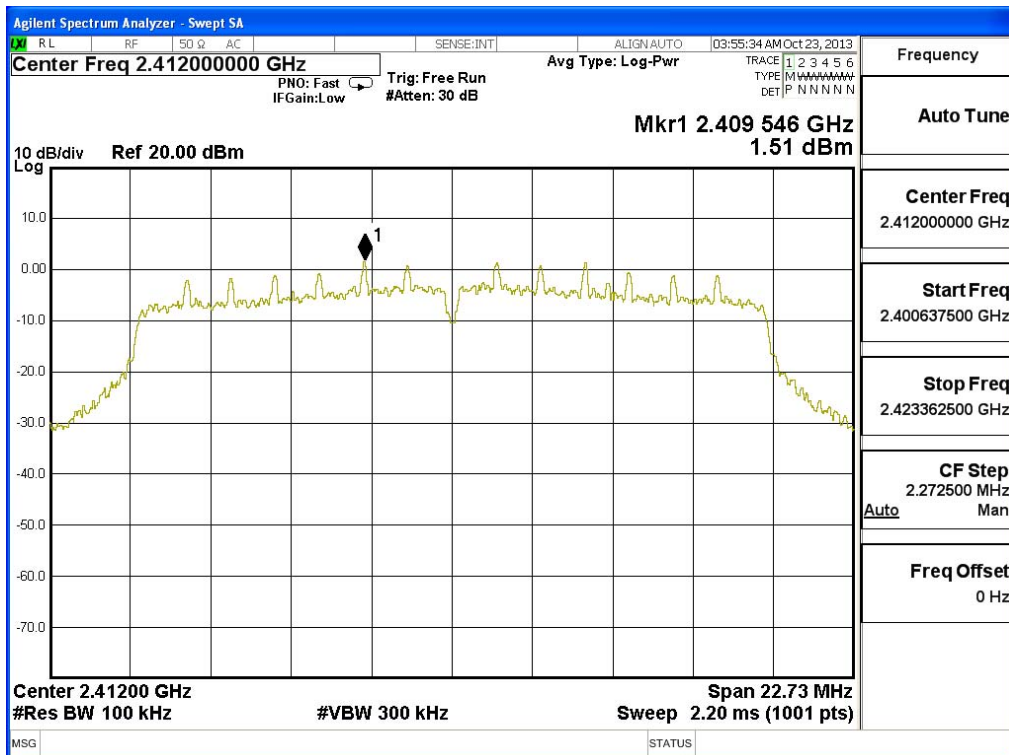

Product : AIS Class B Transponder
 Test Item : Power Density Data
 Test Site : No.3OATS
 Test Mode : Mode 3: Transmit (802.11n MCS0 7.2Mbps 20M-BW) (2437MHz)

Channel No.	Frequency (MHz)	Measurement Level (dBm)	Required Limit (dBm)	Result
6	2437	2.670	< 8dBm	Pass

Figure Channel 6:

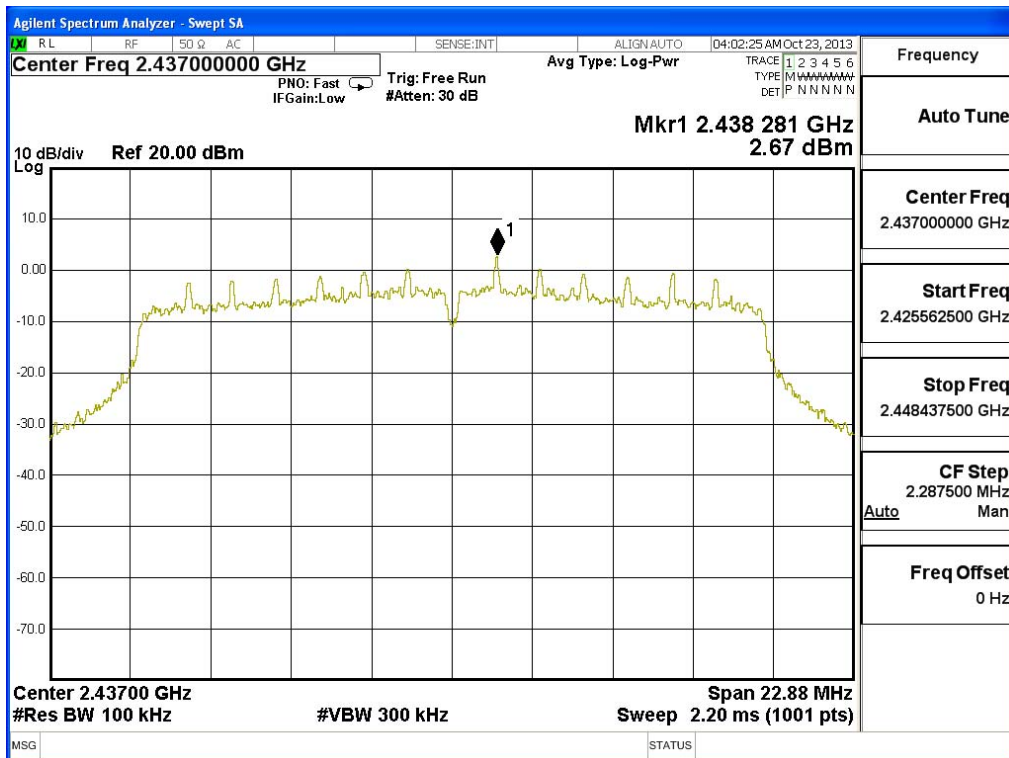

Product : AIS Class B Transponder
 Test Item : Power Density Data
 Test Site : No.3 OATS
 Test Mode : Mode 3: Transmit (802.11n MCS0 7.2Mbps 20M-BW) (2462MHz)

Channel No.	Frequency (MHz)	Measurement Level (dBm)	Required Limit (dBm)	Result
11	2462	2.180	< 8dBm	Pass

Figure Channel 11:

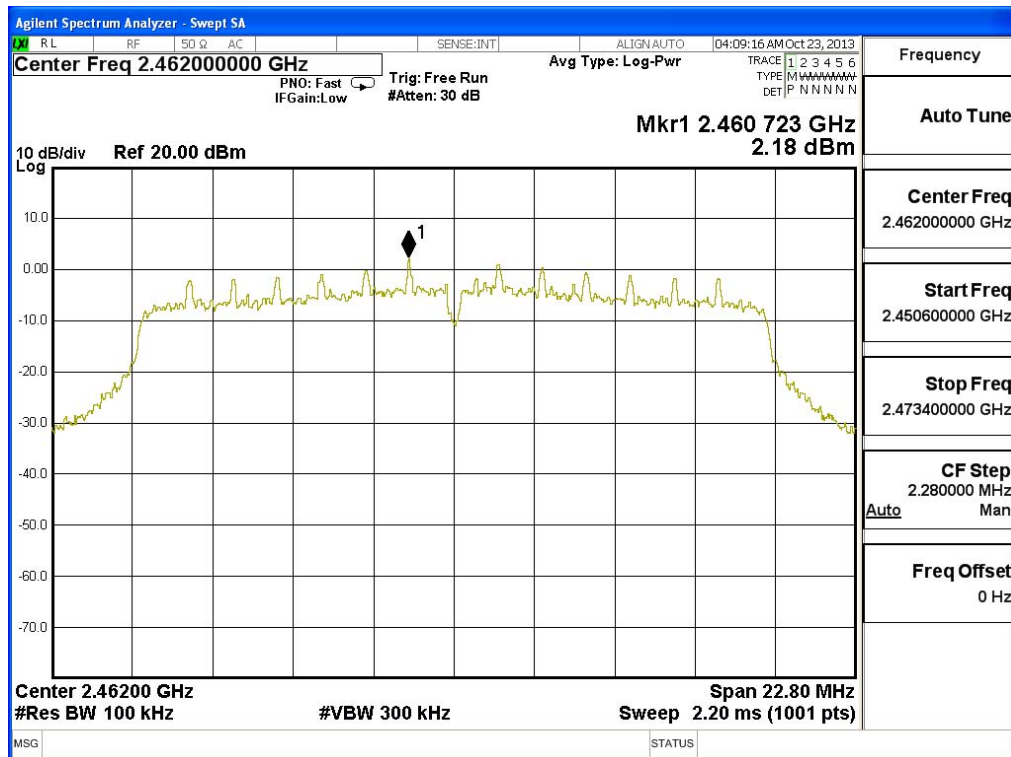

9. EMI Reduction Method During Compliance Testing

No modification was made during testing.

Attachment 1: EUT Test Setup Photographs

Attachment 1: EUT Test Setup Photographs

Front View of Conducted Test

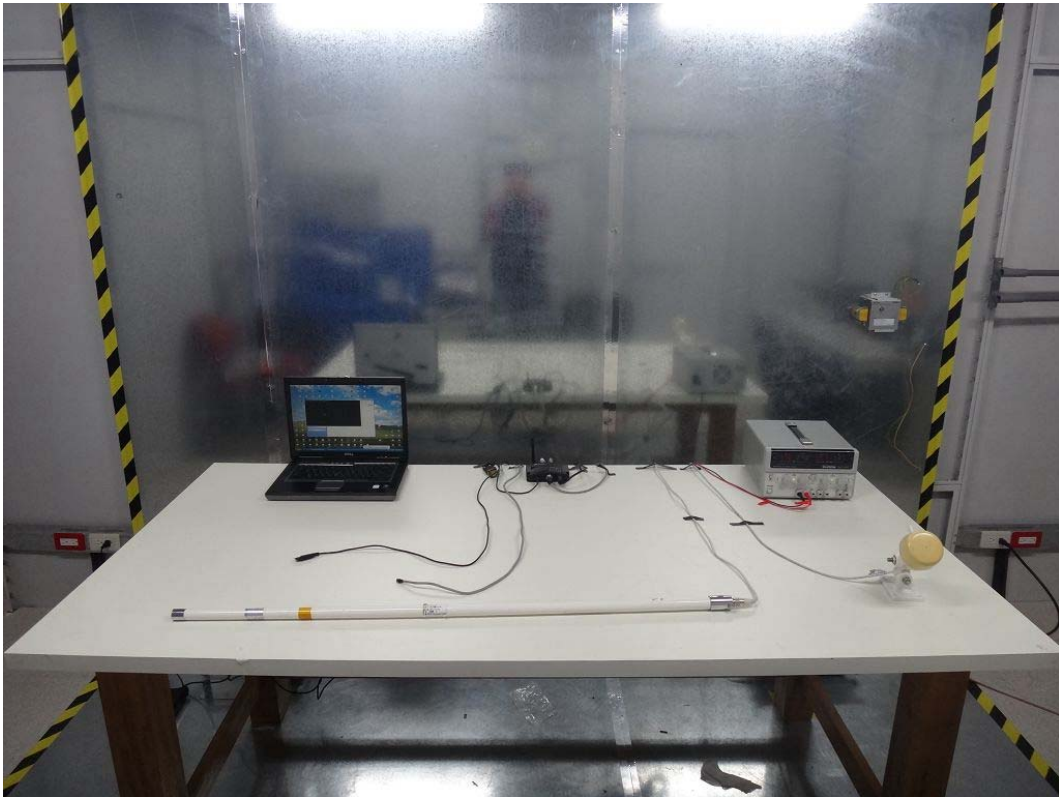

Back View of Conducted Test



Front View of Radiated Test



Back View of Radiated Test

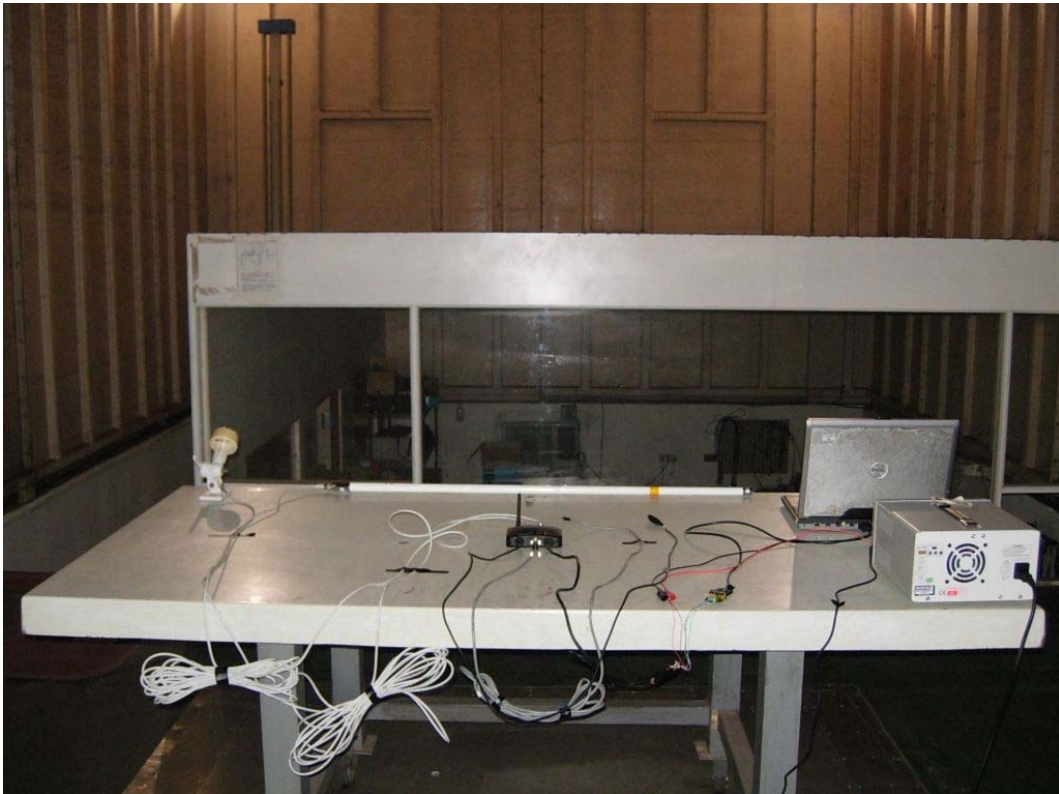

Front View of Radiated Test (Horn)



Back View of Radiated Test (Horn)

