

CE EMC TEST REPORT

For

AIS Class B Transponder

MODEL: WideLink B600W; WideLink B600

Test Report Number:

T160222W01-RE1

Issued to:

Alltek Marine Electronics Corp.

**14F-2, No.237, Sec. 1, Datong Rd., Xizhi District,
New Taipei City, Taiwan, R.O.C.**

Issued by:

Compliance Certification Services Inc.

Xindian Lab.

**No.163-1, Jhongsheng Rd., Xindian Dist.,
New Taipei City, 23151 Taiwan.**

TEL: 886-2-22170894

FAX: 886-2-22171029

Issued Date: January 18, 2017



Note: This report shall not be reproduced except in full, without the written approval of Compliance Certification Services Inc. This document may be altered or revised by Compliance Certification Services Inc. personnel only, and shall be noted in the revision section of the document. The client should not use it to claim product endorsement by TAF, A2LA, NIST or any government agencies. The test results in the report only apply to the tested sample.

Revision History

Rev.	Issue Date	Revisions	Effect Page	Revised By
00	January 18, 2017	Initial Issue	ALL	Andrea Chen

TABLE OF CONTENTS

1 TEST CERTIFICATION 4

2 TEST RESULT SUMMARY 5

3 EUT DESCRIPTION 6

4 TEST METHODOLOGY 7

 4.1. DECISION OF FINAL TEST MODE 7

 4.2. EUT SYSTEM OPERATION 7

5 SETUP OF EQUIPMENT UNDER TEST 8

 5.1. DESCRIPTION OF SUPPORT UNITS 8

 5.2. CONFIGURATION OF SYSTEM UNDER TEST 9

6 FACILITIES AND ACCREDITATIONS 10

 6.1. FACILITIES 10

 6.2. ACCREDITATIONS 10

 6.3. MEASUREMENT UNCERTAINTY 10

7 EMISSION TEST 11

 7.1. CONDUCTED EMISSION MEASUREMENT 11

 7.2. CONDUCTED EMISSION MEASUREMENT AT TELECOMMUNICATION PORTS 15

 7.3. RADIATED EMISSION MEASUREMENT 18

 7.4. HARMONICS CURRENT MEASUREMENT 26

 7.5. VOLTAGE FLUCTUATION AND FLICKS MEASUREMENT 28

8 IMMUNITY TEST 30

 8.1. GENERAL DESCRIPTION 30

 8.2. ELECTROSTATIC DISCHARGE (ESD) 33

 8.3. RADIATED, RADIO-FREQUENCY, ELECTROMAGNETIC FIELD (RS) 38

 8.4. ELECTRICAL FAST TRANSIENT (EFT) 41

 8.5. SURGE IMMUNITY TEST 44

 8.6. CONDUCTED RADIO FREQUENCY DISTURBANCES (CS) 46

 8.7. VOLTAGE DIP & VOLTAGE INTERRUPTIONS 49

9 PHOTOGRAPHS OF THE TEST CONFIGURATION 51

APPENDIX 1 - PHOTOGRAPHS OF EUT A1-1

1 TEST CERTIFICATION

Product:	AIS Class B Transponder
Model:	WideLink B600W; WideLink B600
Brand:	AMEC
Applicant:	Alltek Marine Electronics Corp. 14F-2, No.237, Sec. 1, Datong Rd., Xizhi District, New Taipei City, Taiwan, R.O.C.
Manufacturer:	Alltek Marine Electronics Corp. 14F-2, No.237, Sec. 1, Datong Rd., Xizhi District, New Taipei City, Taiwan, R.O.C.
Tested:	February 25, 2016 ~ April 21, 2016
Test Voltage:	12VDC/24VDC
Applicable Standards:	ETSI EN 301 489-1 V1.9.2 2011 ETSI EN 301 489-3 V1.6.1 2013 EN 55022: 2010 / AC: 2011 EN 61000-3-2: 2014 EN 61000-3-3: 2013 EN 61000-4-2: 2009 EN 61000-4-3: 2006 + A1: 2008 + A2: 2010 EN 61000-4-4: 2012 EN 61000-4-5: 2014 EN 61000-4-6: 2014 EN 61000-4-11: 2004

Deviation from Applicable Standard
None.

The above equipment has been tested by Compliance Certification Services Inc., and found compliance with the requirements set forth in the technical standards mentioned above. The results of testing in this report apply only to the product/system, which was tested. Other similar equipment will not necessarily produce the same results due to production tolerance and measurement uncertainties.

Approved by:

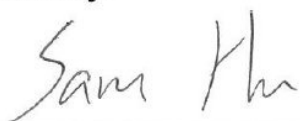

Sam Hu
Assistant Manager

Reviewed by:



Eva Fan
Supervisor of report document dept.

2 TEST RESULT SUMMARY

EMISSION			
Standard	Item	Result	Remarks
EN 55022: 2010 / AC: 2011	Conducted (Main Port)	N/A	Please see the page 14
	Conducted (Telecom port)	N/A	Please see the page 17
	Radiated	PASS	Meet Class B limit
EN 61000-3-2: 2014	Harmonic current emissions	N/A	Please see the page 27
EN 61000-3-3:2013	Voltage fluctuations & flicker	N/A	Please see the page 29

IMMUNITY			
Standard	Item	Result	Remarks
EN 61000-4-2: 2009	ESD	PASS	Meets the requirements of Performance Criterion CT&CR
EN 61000-4-3: 2006 + A1: 2008 + A2: 2010	RS	PASS	Meets the requirements of Performance Criterion CT&CR
EN 61000-4-4: 2012	EFT	PASS	Meets the requirements of Performance Criterion CT&CR
EN 61000-4-5: 2014	Surge	N/A	Please see the page 45
EN 61000-4-6: 2014	CS	PASS	Meets the requirements of Performance Criterion CT&CR
EN 61000-4-11: 2004	Voltage dips & voltage variations	N/A	Please see the page 50

- Note:** 1. The statements of test result on the above are decided by the request of test standard only; the measurement uncertainties are not factored into this compliance determination.
 2. The information of measurement uncertainty is available upon the customer's request.

Classification of SRD equipment

The product family of Short Range Devices is divided into three classes of equipment, each having its own set of minimum performance criteria. This classification is based upon the impact on persons and/or goods in case the equipment does not operate above the specified minimum performance level under EMC stress.

Table 3

Class of SRD equipment	Risk assessment of receiver performance
<input type="checkbox"/> 1	Highly reliable SRD communication media; e.g. serving human life inherent systems (may result in a physical risk to a person)
<input type="checkbox"/> 2	Medium reliable SRD communication media; e.g. causing inconvenience to persons, which cannot simply be overcome by other means
<input checked="" type="checkbox"/> 3	Standard reliable SRD communication media; e.g. inconvenience to persons, which can simply be overcome by other means (e.g. manual)

3 EUT DESCRIPTION

Product	AIS Class B Transponder
Brand Name	AMEC
Model	WideLink B600W; WideLink B600
Applicant	Alltek Marine Electronics Corp.
Housing material	Plastic
Identify Number	T160222W01
Received Date	February 22, 2016
EUT Power Rating	12VDC/24VDC from DC power supply
Hardware	M-PCB-B601MBV2
Software	V1.1.5
Frequency Range	IEEE 802.11b/g/ IEEE 802.11n HT 20 MHz Mode: 2412 ~ 2472 MHz IEEE 802.11n HT 40 MHz Mode: 2422~ 2462 MHz
Transmit Power (mean EIRP)	IEEE 802.11b Mode: 19.53dBm (89.7429mW) IEEE 802.11g Mode: 19.52dBm (89.5365mW) IEEE 802.11n HT 20 MHz Mode: 19.48dBm (88.7156mW) IEEE 802.11n HT 40 MHz Mode: 19.49dBm (88.9201mW)
Modulation Technique	IEEE 802.11b Mode: DSSS IEEE 802.11g Mode: OFDM IEEE 802.11n HT 20 MHz Mode: OFDM IEEE 802.11n HT 40 MHz Mode: OFDM
Number of Channels	IEEE 802.11b/g Mode: 13 Channels IEEE 802.11n HT 20 MHz Mode: 13 Channels IEEE 802.11n HT 40 MHz Mode: 9 Channels
Antenna Specification	CHIP Antenna: 1.00 dBi Dipole Antenna:: 2.94 dBi
Temperature Range	-15°C ~ +55°C

Model Differences

Model Name	Difference	Tested (Check)
WideLink B600W	With Wi-Fi Function	<input checked="" type="checkbox"/>
WideLink B600	Without Wi-Fi Function	<input type="checkbox"/>

I/O PORT

I/O PORT TYPES	Q'TY	TESTED WITH
1. USB Port	1	1
2. GPS Antenna Port	1	1
3. VHF Antenna Port	1	1
4. NMEA 0183 Port	2	2
5. NMEA 2000 Port	1	1
6. Micro SD Slot	1	1

Note: Client consigns only one model sample to test (Model Number: WideLink B600W).

4 TEST METHODOLOGY**4.1. DECISION OF FINAL TEST MODE**

The EUT was tested together with the below additional components, and a configuration, which produced the worst emission levels, was selected and recorded in this report.

The test configuration modes are as the following:

Radiation Modes:

1	12VDC MODE
	12VDC MODE / 1-6GHz
2	24VDC MODE

Worst:

Conduction: N/A (The subject equipment is not intended to be connected to AC mains supply. Therefore, this test is not applicable)

Radiation: Mode 1

4.2. EUT SYSTEM OPERATION

1. All peripherals connect EUT to test.

5 SETUP OF EQUIPMENT UNDER TEST

5.1. DESCRIPTION OF SUPPORT UNITS

The EUT has been tested as an independent unit together with other necessary accessories or support units. The following support units or accessories were used to form a representative test configuration during the tests.

Peripherals Devices:

No.	Equipment	Model No.	Serial No.	FCC ID / BSMI ID	Brand Name	Data Cable	Power Cord
1	VHF Antenna	ANT-11(TENTA-11) (AMEC P/N:AMEC-ANT-MFB-1200V)	N/A	N/A	AMEC	Shielded, 10m	N/A
2	USB Mouse	M-U0026	N/A	DOC BSMI: T41126	Logitech	Shielded, 1.8m	N/A
3	USB Keyboard	Y-U0011	1346SY01XWV8	DOC BSMI: T51160	Logitech	Shielded, 1.8m	N/A
4	GPS Antenna	ANT-21 (AGGRESSOR-21) (AGGRESSOR-111-C) (AMEC P/N:M-ANT-C1283-570001-A)	N/A	N/A	AMEC	Shielded, 10m	N/A
5	Host PC	DCSM	HBQHY1S	DOC BSMI: R33002	DELL	N/A	Unshielded, 1.8m
6	Monitor	P2314Ht	N/A	DOC BSMI: R33002	DELL	Shielded, 1.8m with two cores	Unshielded, 1.8m
7	Adaptor	YS-1015-U12	N/A	N/A	YHi	N/A	Unshielded, 1.8m
8	NMEA 0183 Cable	N/A	N/A	N/A	AMEC	Unshielded, 2.0m	N/A
9	NMEA 2000 Cable	N/A	N/A	N/A	AMEC	Unshielded, 0.9m	N/A
10	Micro SD Card	N/A	N/A	N/A	PQI	N/A	N/A
11	Mini USB to USB cable	N/A	N/A	N/A	AMEC	Shielded, 1.8m	N/A

Note:

- 1) All the equipment/cables were placed in the worst-case configuration to maximize the emission during the test.
- 2) Grounding was established in accordance with the manufacturer's requirements and conditions for the intended use.

5.2. CONFIGURATION OF SYSTEM UNDER TEST

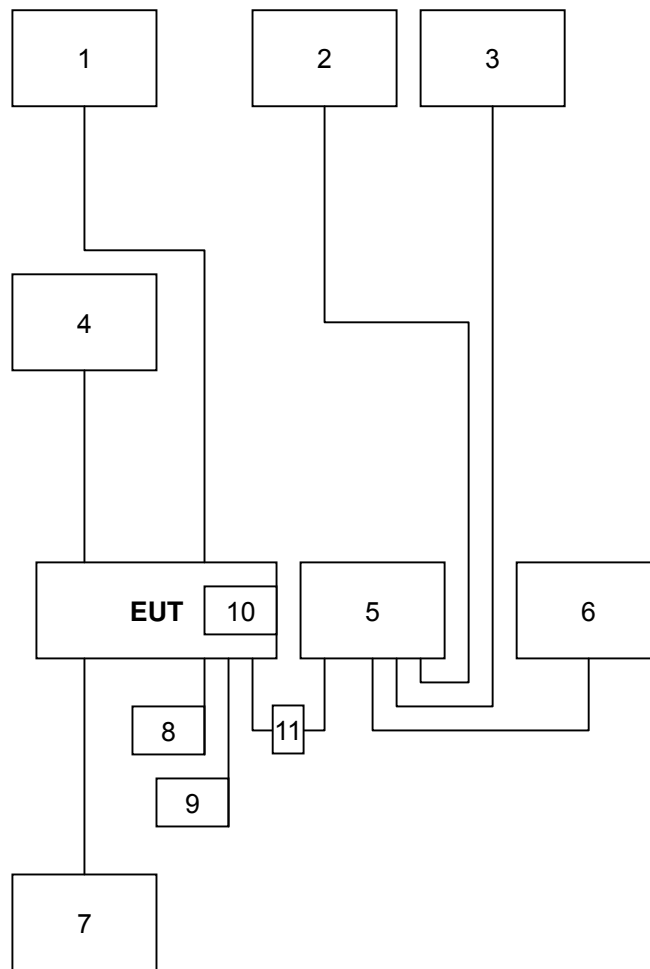

6 FACILITIES AND ACCREDITATIONS

6.1. FACILITIES

All measurement facilities used to collect the measurement data are located at:

- No.163-1, Jhongsheng Rd., Xindian Dist., New Taipei City, 23151 Taiwan.
- No.81-1, Lane 210, Bade 2nd Rd., Lujhu Township, Taoyuan County 33841, TAIWAN, R.O.C.
- No.11, Wu-Gong 6th Rd., Wugu Industrial Park, New Taipei City 248, Taiwan (R.O.C.)
- No.139, Wugong Rd., Wugu Industrial Park, New Taipei City 248, Taiwan (R.O.C.)

The sites are constructed in conformance with the requirements of ANSI C63.4 and CISPR Publication 22. All receiving equipment conforms to CISPR 16-1-1, CISPR 16-1-2, CISPR 16-1-3, CISPR 16-1-4, CISPR 16-1-5.

6.2. ACCREDITATIONS

Our laboratories are accredited and approved by the following accreditation body according to ISO/IEC 17025.

Taiwan	TAF
USA	A2LA

The measuring facility of laboratories has been authorized or registered by the following approval agencies.

Canada	Industry Canada
Norway	Nemko
Japan	VCCI
Taiwan	BSMI
USA	FCC

Copies of granted accreditation certificates are available for downloading from our web site, <http://www.ccsrf.com>

6.3. MEASUREMENT UNCERTAINTY

Where relevant, the following measurement uncertainty levels have been estimated for tests performed on the EUT as specified in CISPR 16-4-2:

Measurement	Frequency	Uncertainty
Conducted emissions	0.15MHz ~ 30MHz	N/A
Radiated emissions	30MHz ~ 1000MHz	± 4.12
	1000MHz ~ 6000MHz	± 4.74

This uncertainty represents an expanded uncertainty expressed at approximately the 95% confidence level using a coverage factor of k=2.

Consistent with industry standard (e.g. CISPR 22: 2005, clause 11, Measurement Uncertainty) determining compliance with the limits shall be base on the results of the compliance measurement. Consequently the measure emissions being less than the maximum allowed emission result in this be a compliant test or passing test.

The acceptable measurement uncertainty value without requiring revision of the compliance statement is base on conducted and radiated emissions being less than U_{CISPR} which is 3.6dB and 5.2dB respectively. CCS values (called U_{Lab} in CISPR 16-4-2) is less than U_{CISPR} as shown in the table above. Therefore, MU need not be considered for compliance.

7 EMISSION TEST

7.1. CONDUCTED EMISSION MEASUREMENT

7.1.1. LIMITS

Table 5: Limits for conducted emissions

Frequency (MHz)	Quasi-peak	Average
0.15 - 0.5	66 - 56	56 - 46
0.50 - 5.0	56	46
5.0 - 30.0	60	50

- Note:**
1. The lower limit shall apply at the transition frequencies.
 2. The limit decreases in line with the logarithm of the frequency in the range of 0.15 to 0.50 MHz.
 3. All emanations from a class A/B digital device or system, including any network of conductors and apparatus connected thereto, shall not exceed the level of field strengths specified above.

Alternatively, for equipment intended to be used in telecommunication centres only, the limits given in table 6 may be used.

Table 6: Limits for conducted emissions of equipment intended to be used in telecommunication centres only

Frequency (MHz)	Quasi-peak	Average
0.15 - 0.5	79	66
0.50 – 30.0	73	60

7.1.2. TEST INSTRUMENTS

Conducted Emission Room #				
Name of Equipment	Manufacturer	Model	Serial Number	Calibration Due

- Note:**
1. The calibration interval of the above test instruments is 12 months and the calibrations are traceable to NML/ROC and NIST/USA.
 2. N.C.R. = No Calibration Request.

7.1.3. TEST PROCEDURES (please refer to measurement standard or CCS SOP PA-031)**Procedure of Preliminary Test**

- The EUT and support equipment, if needed, were set up as per the test configuration to simulate typical usage per the user's manual. When the EUT is a tabletop system, a wooden table with a height of 0.8 meters is used and is placed on the ground plane as per EN 55022 (see Test Facility for the dimensions of the ground plane used). When the EUT is a floor standing equipment, it is placed on the ground plane, which has a 3-12 mm non-conductive covering to insulate the EUT from the ground plane.
- All I/O cables were positioned to simulate typical actual usage as per EN 55022.
- The test equipment EUT installed by AC main power, through a Line Impedance Stabilization Network (LISN), which supplied power source and was grounded to the ground plane.
- All support equipment power by from a second LISN.
- The test program of the EUT was started. Emissions were measured on each current carrying line of the EUT using an EMI Test Receiver connected to the LISN powering the EUT.
- The Receiver scanned from 150kHz to 30MHz for emissions in each of the test modes.
- During the above scans, the emissions were maximized by cable manipulation.
- The test mode(s) described in Item 4.1 were scanned during the preliminary test.
- After the preliminary scan, we found the test mode described in Item 4.1 producing the highest emission level.
- The worst configuration of EUT and cable of the above highest emission level were recorded for reference of the final test.

Procedure of Final Test

- EUT and support equipment were set up on the test bench as per the configuration with highest emission level in the preliminary test.
- A scan was taken on both power lines, Line 1 and Line 2, recording at least the six highest emissions. Emission frequency and amplitude were recorded into a computer in which correction factors were used to calculate the emission level and compare reading to the applicable limit.
- The test data of the worst-case condition(s) was recorded.

7.1.4. TEST SETUP

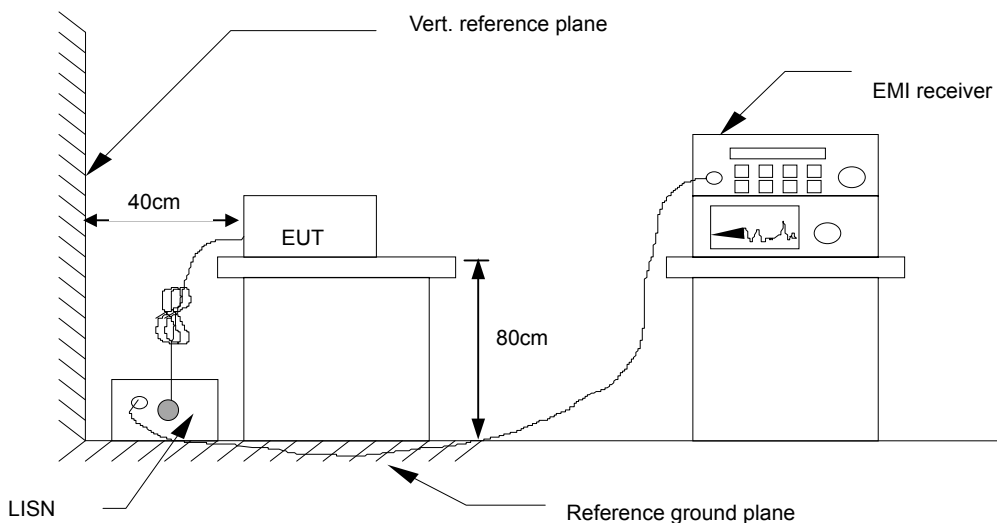

- For the actual test configuration, please refer to the related item – Photographs of the Test Configuration.

7.1.5. Data Sample

Freq. (MHz)	Reading (dBuV)	Factor (dB)	Result (dBuV)	Limit (dBuV)	Margin (dB)	Detector (P/Q/A)	Line (L1/L2)
x.xx	42.95	0.55	43.50	56	-12.50	Q	L1

- Freq. = Emission frequency in MHz
- Reading = Uncorrected Analyzer/Receiver reading
- Factor = Insertion loss of LISN + Cable Loss + Pulse Limit
- Result = Reading + Factor
- Limit = Limit stated in standard
- Margin = Reading in reference to limit
- P = Peak Reading
- Q = Quasi-peak Reading
- A = Average Reading
- L1 = Hot side
- L2 = Neutral side

Calculation Formula

Margin (dB) = Result (dBuV) – Limit (dBuV)

7.1.6. TEST RESULTS

Model No.	N/A	6dB Bandwidth	N/A
Environmental Conditions	N/A	Test Mode	N/A
Tested by	N/A		

Note: The subject equipment is not intended to be connected to AC mains supply. Therefore, this test is not applicable.

7.2. CONDUCTED EMISSION MEASUREMENT AT TELECOMMUNICATION PORTS

7.2.1. LIMITS

The telecommunication ports shall meet the class B limits given in EN 55022 [1].

Frequency (MHz)	Voltage Limit (dBuV)		Current Limit (dBuA)	
	Quasi-peak	Average	Quasi-peak	Average
0.15 - 0.5	84 ~ 74	74 ~ 64	40 ~ 30	30 ~ 20
0.5 - 30.0	74	64	30	20

Note: The limits decrease linearly with the logarithm of the frequency in the range 0,15 MHz to 0,5 MHz.

Alternatively, for equipment intended to be used in telecommunication centres only, the class A limits given in EN 55022 [1] may be used.

Frequency (MHz)	Voltage Limit (dBuV)		Current Limit (dBuA)	
	Quasi-peak	Average	Quasi-peak	Average
0.15 ~ 0.5	97 ~ 87	84 ~ 74	53 ~ 43	40 ~ 30
0.5 ~ 30.0	87	74	43	30

NOTE: The limits decrease linearly with the logarithm of the frequency in the range 0.15 MHz to 0.5 MHz.

7.2.2. TEST INSTRUMENTS

Conducted Emission room #				
Name of Equipment	Manufacturer	Model	Serial Number	Calibration Due

Note: 1. The calibration interval of the above test instruments is 12 months and the calibrations are traceable to NML/ROC and NIST/USA.
 2. N.C.R = No Calibration Request.

7.2.3. TEST PROCEDURE (please refer to measurement standard or CCS SOP PA-031)

- Selecting ISN for unscreened cable or a current probe for screened cable to take measurement.
- The port of the EUT was connected to the remote side support equipment through the ISN/Current Probe and communication in normal condition.
- Making a overall range scan by using the test receiver controlled by controller and record at least six highest emissions for showing in the test report.
- Emission frequency and amplitude were recorded into a computer in which correction factors were used to calculate the emission level and compare reading to the applicable limit.
- In case of measuring on the screened cable, the current limit shall be applied; otherwise the voltage limit should be applied.
- The following test mode was scanned during the preliminary test:

N/A

- After the preliminary scan, we found the following test mode(s) producing the highest emission level and test data of the worst case was recorded.

N/A

7.2.4. TEST SETUP

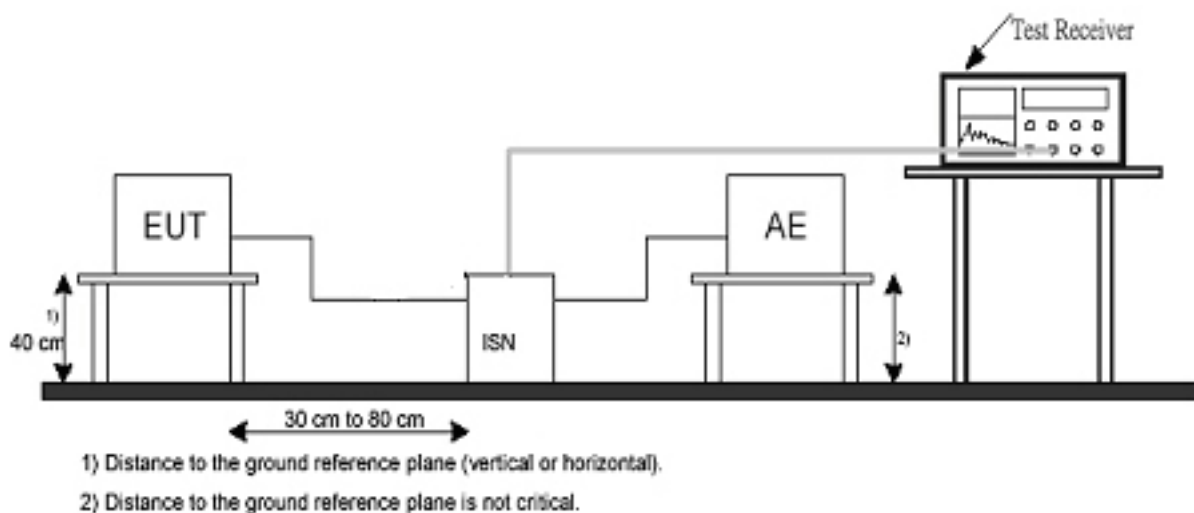

- For the actual test configuration, please refer to the related item – Photographs of the Test Configuration.

7.2.5. Data Sample

Freq. (MHz)	Reading (dBuV)	Factor (dB)	Result (dBuV)	Limit (dBuV)	Margin (dB)	Detector (P/Q/A)
x.xx	62.95	0.55	63.50	84	-20.50	Q

- Freq. = Emission frequency in MHz
- Reading = Uncorrected Analyzer/Receiver reading
- Factor = Insertion loss of LISN + Cable Loss + Pulse Limit
- Result = Reading + Factor
- Limit = Limit stated in standard
- Margin = Reading in reference to limit
- P = Peak Reading
- Q = Quasi-peak Reading
- A = Average Reading

Calculation Formula

Margin (dB) = Result (dBuV) – Limit (dBuV)

7.2.6. TEST RESULTS

Model No.	N/A	6dB Bandwidth	N/A
Environmental Conditions	N/A	Test Mode	N/A
Tested by	N/A		

Note: No applicable, the EUT doesn't have LAN Port or Modem port.

7.3. RADIATED EMISSION MEASUREMENT

7.3.1. LIMITS

FREQUENCY (MHz)	Limit (quasi-peak) dBuV/m	
	Class B	Class A
30 ~ 230	30	40
230 ~ 1000	37	47

Note: 1. The lower limit shall apply at the transition frequencies.
 2. Alternatively, for ancillary equipment intended to be used in telecommunication centres only, the class A limits given in EN 55022 [1] may be used.

Table 3: Limits for radiated disturbance above 1 GHz at a measurement distance of 3 m

Frequency (GHz)	Average Limit dB(uV/m)	Peak Limit dB(uV/m)
1 ~ 3	50	70
3 ~ 6	54	74

Note: The lower limit applies at the transition frequency.

Alternatively, for ancillary equipment intended to be used in telecommunication centres only, the class A limits given in EN 55022 [1] and the limits above 1 GHz shown in table 4 apply.

Table 4: Limits above 1 GHz for radiated emissions from ancillary equipment intended for use in telecommunication centres only, and measured on a stand alone basis at a measurement distance of 3 m

Frequency (GHz)	Average Limit dB(uV/m)	Peak Limit dB(uV/m)
1 ~ 3	56	76
3 ~ 6	60	80

Note: The lower limit applies at the transition frequency.

7.3.2. TEST INSTRUMENTS

Open Area Test Site # H				
Name of Equipment	Manufacturer	Model	Serial Number	Calibration Due
EMI Test Receiver	R&S	ESCI	101340	04/07/2016
Pre-Amplifier	HP	8447D	1937A01554	10/01/2016
CABLE	EMCI	CFD400-E	N-Type#H10	04/08/2016
Thermo-Hygro Meter	Wisewind	201A	No. 03	06/02/2016
Test S/W	EZ-EMC			
Above 1GHz Used				
Signal Analyzer (9k – 44GHz)	Agilent	N9010A	MY53440125	12/13/2016
Horn Antenna (1 – 18GHz)	EMCO	3117	00139062	10/21/2016
Pre-Amplifier (1 – 26.5GHz)	HP	8449B	3008A01266	12/13/2016
CABLE (1 – 18GHz)	Rosnol	A1K50-EW0630	151126-1	12/16/2016
THERMO- HYGRO METER	WISEWIND	201A	No. 02	05/10/2016
Test S/W	EZ-EMC			

NOTE: 1. The calibration interval of the above test instruments is 12 months and the calibrations are traceable to NML/ROC and NIST/USA.
 2. N.C.R. = No Calibration Request.

7.3.3. TEST PROCEDURE (please refer to measurement standard or CCS SOP PA-031)**Frequency range 30MHz ~ 1GHz**

1. The EUT was placed on the top of a rotating table 0.8 meters above the ground at a 10 meter semi-anechoic chamber room. The table was rotated 360 degrees to determine the position.
2. The EUT was set 10 meters away from the interference-receiving antenna, which was mounted on the top of a variable-height antenna tower.
3. The height of antenna is varied from one meter to four meter above the ground to determine the maximum value of the field strength. Both horizontal and vertical polarizations of the antenna are set to make the measurement.
4. For each suspected emission, the EUT was arranged to its worst case and then the antenna was turned to heights for 1 meter to 4 meters and the turn table was turned from 0 degrees to 360 degrees to find the maximum reading.
5. The test-receiver system was set to quasi-peak detect function and specified bandwidth with maximum hold mode when the test frequency is below 1GHz.

NOTE: The resolution bandwidth of test receiver/spectrum analyzer is 120kHz for Quasi-peak detection (QP) at frequency below 1GHz.

Frequency range above 1GHz

1. The EUT was placed on the top of a rotating table 0.8 meters above the ground at a 3 meter semi-anechoic chamber room. The table was rotated 360 degrees to determine the position.
2. The EUT was set 3 meters away from the directional antenna, which was pointed towards the source of the emission within the EUT. This could be done by either pointing the antenna at an angle towards the source of the emission, or by rotating the EUT, in both height and polarization, to maximize the measured emission.
3. The height of antenna can be varied from one meter to four meters, the height of adjustment depends on the EUT height and the antenna 3 dB beamwidth both, to detect the maximum value of the field strength. Both horizontal and vertical polarizations of the antenna are set to make the measurement.
4. For each suspected emission, the EUT was arranged to its worst case and then the antenna was turned to heights and the rotatable table was turned from 0 degrees to 360 degrees to find the maximum reading.
5. The test-receiver system was set to peak and average detect function and specified bandwidth with maximum hold mode when the test frequency is above 1GHz.

NOTE:

1. The resolution bandwidth is 1MHz and video bandwidth of test receiver/spectrum analyzer is 1 MHz for peak detection at above 1GHz. The resolution bandwidth of test receiver/spectrum analyzer is 1 MHz for average detection (AV) at frequency above 1 GHz.
2. For measurement of frequency above 1GHz, the EUT was set 3 meters away from the directional antenna.

7.3.4. TEST SETUP

Below 1GHz

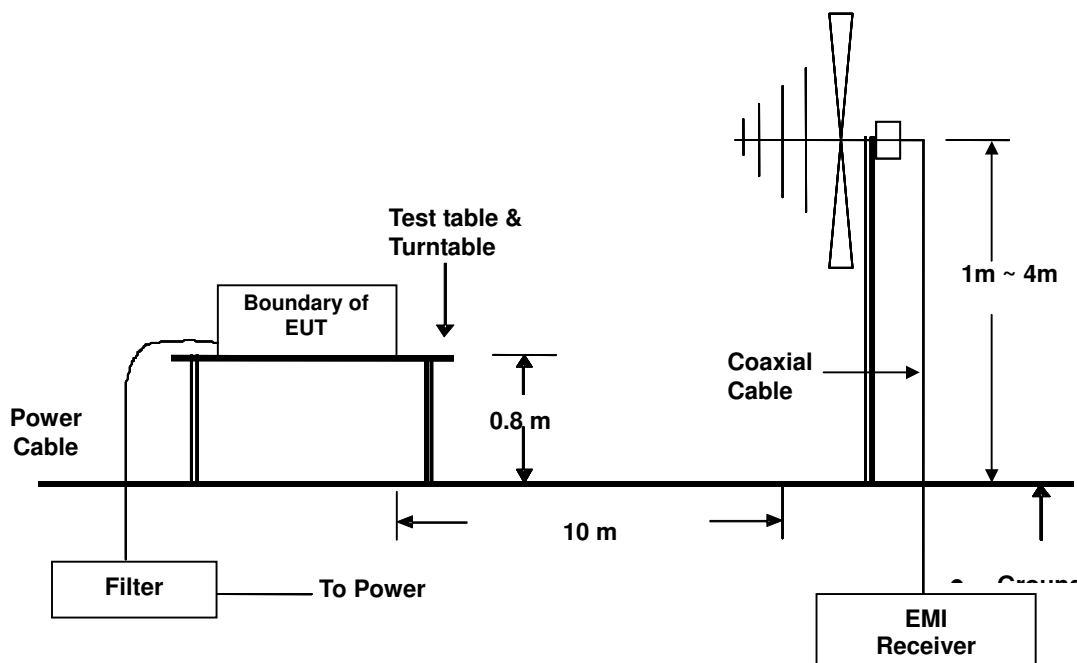

Above 1GHz

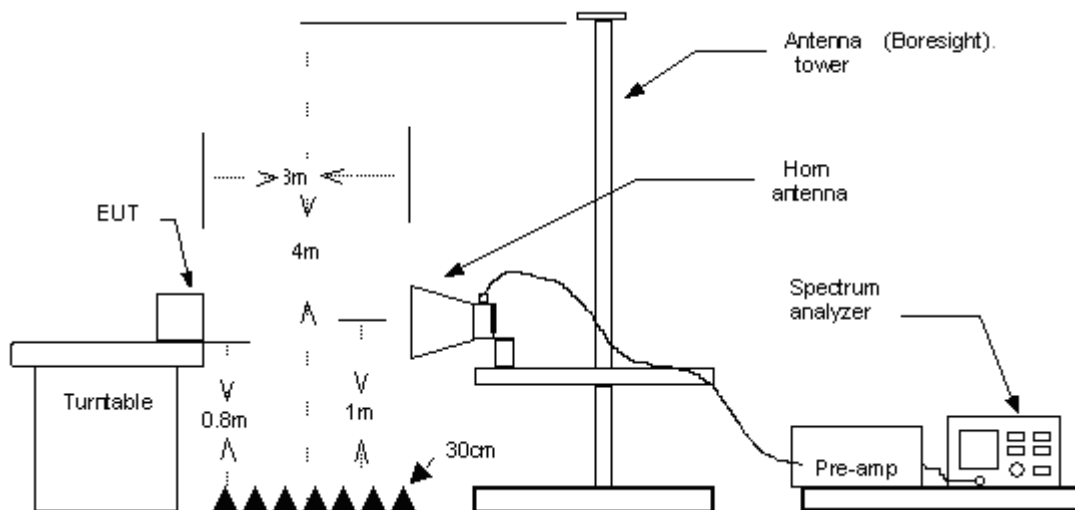

- For the actual test configuration, please refer to the related item – Photographs of the Test Configuration.

7.3.5. Data Sample

Below 1GHz

Freq. (MHz)	Reading (dBuV)	Factor (dB/m)	Result (dBuV/m)	Limit (dBuV/m)	Margin (dB)	Detector (P/Q)	Pol. (H/V)
x.xx	14.0	12.2	26.2	30	-3.8	Q	H

Above 1GHz

Freq. (MHz)	Reading (dBuV)	Factor (dB/m)	Result (dBuV/m)	Limit (dBuV/m)	Margin (dB)	Detector (P/A)	Pol. (H/V)
x.xx	42.95	0.55	43.50	54	-10.50	A	H

- Freq. = Emission frequency in MHz
- Reading = Uncorrected Analyzer/Receiver reading
- Factor = Antenna Factor + Cable Loss - Amplifier Gain
- Result = Reading + Factor
- Limit = Limit stated in standard
- Margin = Reading in reference to limit
- P = Peak Reading
- Q = Quasi-peak Reading
- A = Average Reading
- H = Antenna Polarization: Horizontal
- V = Antenna Polarization: Vertical

Calculation Formula

Margin (dB) = Result (dBuV/m) – Limit (dBuV/m)

7.3.6. TEST RESULTS

Below 1GHz

Model No.	WideLink B600W	Test Mode	Mode 1
Environmental Conditions	24°C, 61% RH	6dB Bandwidth	120 kHz
Antenna Pole	Vertical	Antenna Distance	10m
Detector Function	Quasi-peak.	Tested by	Jim Lian
Standard	EN 55022 CLASS B		

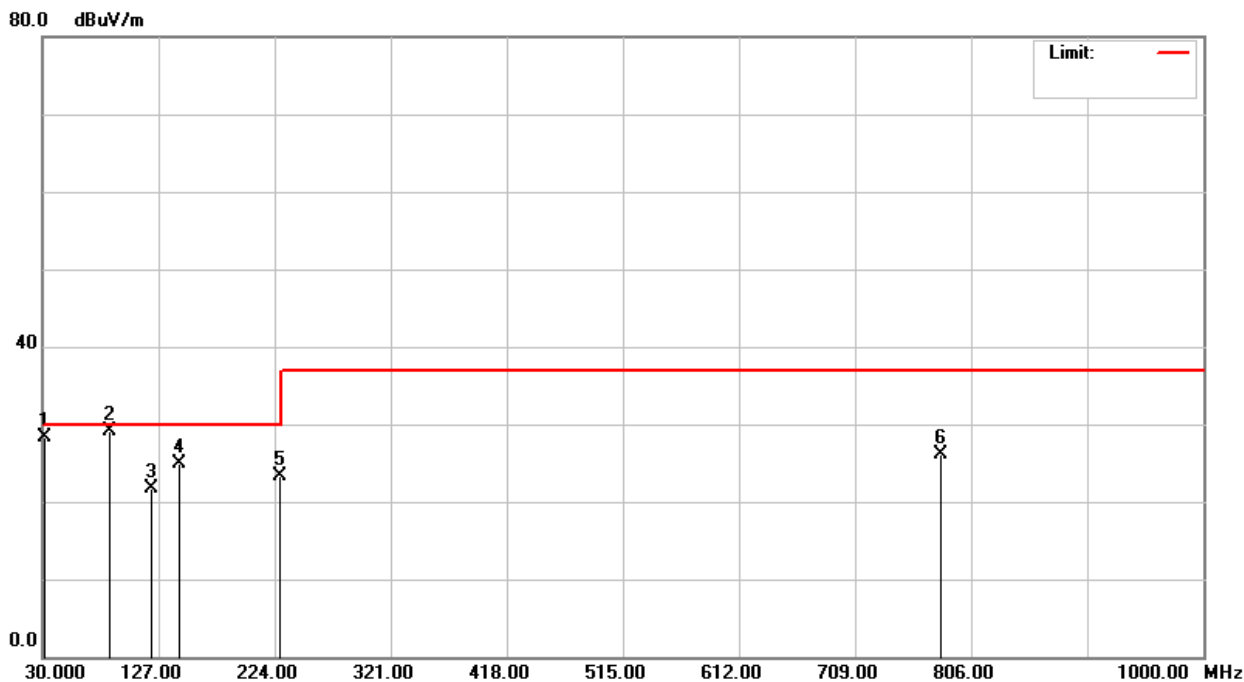

Radiated Emission Readings									
Frequency Range Investigated				30 MHz to 1000 MHz at 10m					
Freq. (MHz)	Reading (dBuV)	Factor (dB/m)	Result (dBuV/m)	Limit (dBuV/m)	Margin (dB)	Height (cm)	Degree (°)	Detector (P/Q)	Pol. (H/V)
32.5040	38.00	-9.77	28.23	30.00	-1.77	100	190	Q	V
86.7840	47.00	-17.96	29.04	30.00	-0.96	100	334	Q	V
121.6200	36.00	-14.39	21.61	30.00	-8.39	100	47	Q	V
143.9800	39.60	-14.76	24.84	30.00	-5.16	100	88	Q	V
228.5000	38.70	-15.47	23.23	30.00	-6.77	100	225	Q	V
780.5600	30.20	-4.01	26.19	37.00	-10.81	400	123	Q	V

Note: P= Peak Reading; Q= Quasi-peak Reading.

Model No.	WideLink B600W	Test Mode	Mode 1
Environmental Conditions	24°C, 61% RH	6dB Bandwidth	120 kHz
Antenna Pole	Horizontal	Antenna Distance	10m
Detector Function	Quasi-peak.	Tested by	Jim Lian
Standard	EN 55022 CLASS B		

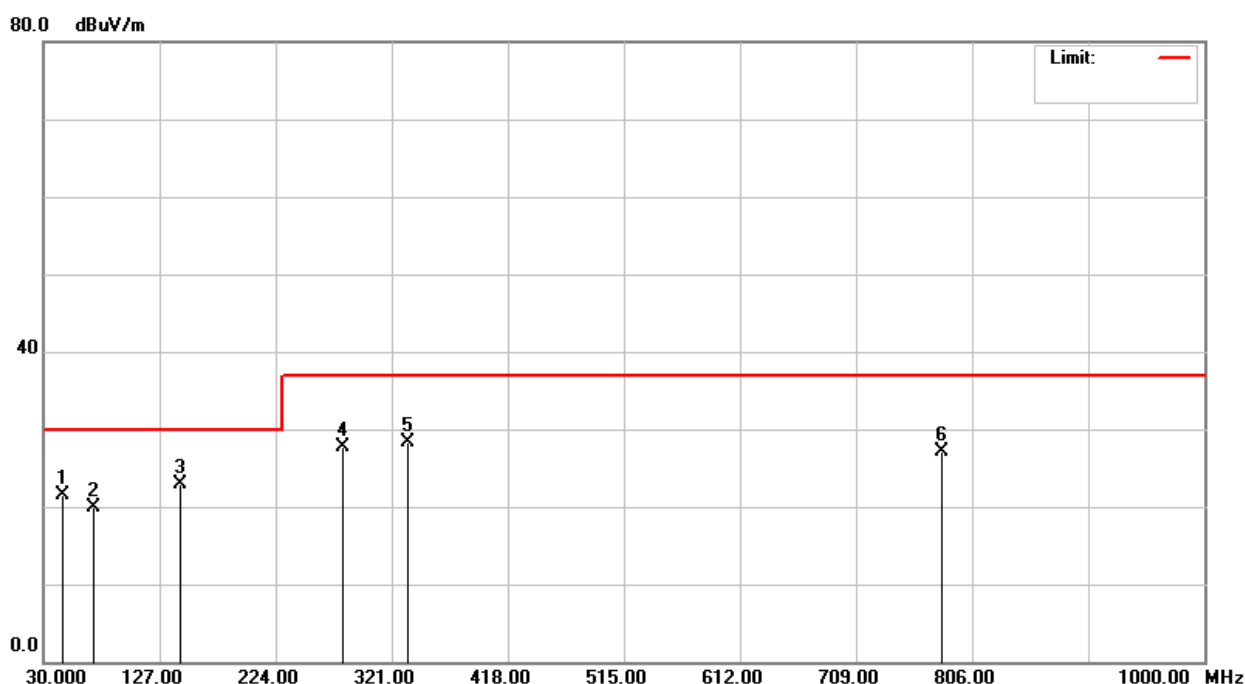

Radiated Emission Readings									
Frequency Range Investigated				30 MHz to 1000 MHz at 10m					
Freq. (MHz)	Reading (dBuV)	Factor (dB/m)	Result (dBuV/m)	Limit (dBuV/m)	Margin (dB)	Height (cm)	Degree (°)	Detector (P/Q)	Pol. (H/V)
45.6800	38.30	-16.75	21.55	30.00	-8.45	400	168	Q	H
71.7800	39.60	-19.67	19.93	30.00	-10.07	400	330	Q	H
143.8200	37.60	-14.75	22.85	30.00	-7.15	400	274	Q	H
280.3400	40.30	-12.65	27.65	37.00	-9.35	400	95	Q	H
334.6800	39.60	-11.29	28.31	37.00	-8.69	400	188	Q	H
780.2400	31.20	-4.01	27.19	37.00	-9.81	100	111	Q	H

Note: P= Peak Reading; Q= Quasi-peak Reading.

Above 1GHz

Model No.	WideLink B600W	Test Mode	Mode 1
Environmental Conditions	22°C, 64% RH	6dB Bandwidth	1 MHz
Antenna Pole	Vertical / Horizontal	Antenna Distance	3m
Highest frequency generated or used	2400MHz	Upper frequency	6000MHz
Detector Function	Peak and average.	Tested by	Kevin Wang
Standard	EN 55022 CLASS B		

Radiated Emission Readings							
Frequency Range Investigated				Above 1GHz at 3m			
Freq. (MHz)	Reading (dBuV)	Factor (dB/m)	Result (dBuV/m)	Limit (dBuV/m)	Margin (dB)	Detector (P/A)	Pol. (H/V)
2091.667	49.11	-3.25	45.86	70.00	-24.14	P	V
2408.333	48.53	-2.80	45.73	70.00	-24.27	P	V
2983.333	47.77	-2.18	45.59	70.00	-24.41	P	V
3825.000	48.03	-1.09	46.94	74.00	-27.06	P	V
4825.000	48.29	-0.03	48.26	74.00	-25.74	P	V
5075.000	48.42	0.13	48.55	74.00	-25.45	P	V

Radiated Emission Readings							
Frequency Range Investigated				Above 1GHz at 3m			
Freq. (MHz)	Reading (dBuV)	Factor (dB/m)	Result (dBuV/m)	Limit (dBuV/m)	Margin (dB)	Detector (P/A)	Pol. (H/V)
1841.667	51.67	-4.81	46.86	70.00	-23.14	P	H
2108.333	49.36	-3.24	46.12	70.00	-23.88	P	H
2408.333	48.56	-2.80	45.76	70.00	-24.24	P	H
2666.667	47.56	-2.49	45.07	70.00	-24.93	P	H
3700.000	48.31	-1.28	47.03	74.00	-26.97	P	H
4825.000	51.03	-0.03	51.00	74.00	-23.00	P	H

Note: P= Peak Reading; A= Average Reading.

7.4. HARMONICS CURRENT MEASUREMENT

7.4.1. LIMITS OF HARMONICS CURRENT MEASUREMENT

Limits for Class A equipment		Limits for Class D equipment		
Harmonics Order n	Max. permissible harmonics current A	Harmonics Order n	Max. permissible harmonics current per watt mA/W	Max. permissible harmonics current A
Odd harmonics		Odd Harmonics only		
3	2.30	3	3.4	2.30
5	1.14	5	1.9	1.14
7	0.77	7	1.0	0.77
9	0.40	9	0.5	0.40
11	0.33	11	0.35	0.33
13	0.21	13	0.30	0.21
15<=n<=39	0.15x15/n	15<=n<=39	3.85/n	0.15x15/n
Even harmonics				
2	1.08			
4	0.43			
6	0.30			
8<=n<=40	0.23x8/n			

NOTE: 1. Class A and Class D are classified according to item 7.4.3.
 2. According to section 7 of EN 61000-3-2, the above limits for all equipment except for lighting equipment having an active input power > 75 W and no limits apply for equipment with an active input power up to and including 75 W.

7.4.2. TEST INSTRUMENTS

Name of Equipment	Manufacturer	Model	Serial Number	Calibration Due

NOTE: The calibration interval of the above test instruments is 12 months and the calibrations are traceable to NML/ROC and NIST/USA.

7.4.3. TEST PROCEDURE (please refer to measurement standard or CCS SOP PA-029)

- The EUT was placed on the top of a wooden table 0.8 meters above the ground and operated to produce the maximum harmonic components under normal operating conditions for each successive harmonic component in turn.
- The classification of EUT is according to section 5 of EN 61000-3-2.
- The EUT is classified as follows:

Class A: Balanced three-phase equipment, Household appliances excluding equipment as Class D, Tools excluding portable tools, Dimmers for incandescent lamps, audio equipment, equipment not specified in one of the three other classes.

Class B: Portable tools; Arc welding equipment which is not professional equipment.

Class C: Lighting equipment.

Class D: Equipment having a specified power less than or equal to 600 W of the following types: Personal computers and personal computer monitors; television receivers and refrigerators and freezers having one or more variable-speed drives to control compressor motor(s).

- The correspondent test program of test instrument to measure the current harmonics emanated from EUT is chosen. The measure time shall be not less than the time necessary for the EUT to be exercised.

7.4.4. TEST SETUP

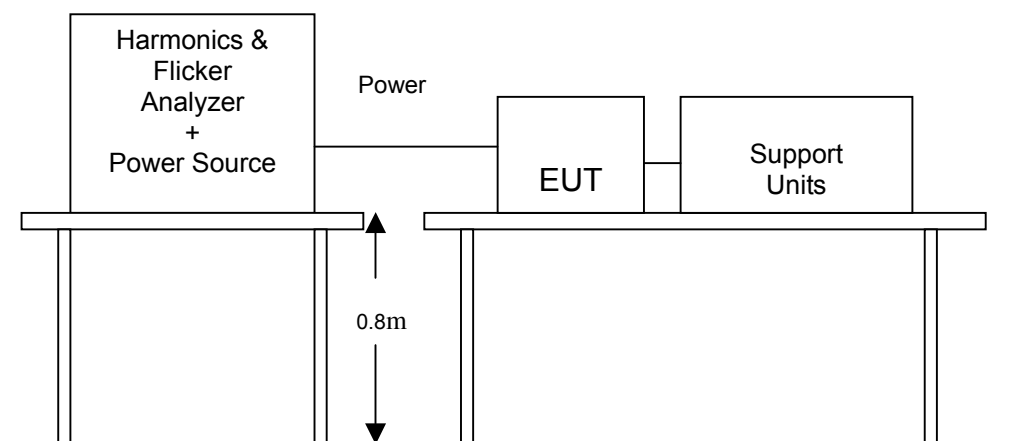

- For the actual test configuration, please refer to the related item – Photographs of the Test Configuration.

7.4.5. TEST RESULTS

Power Consumption	N/A	Test Results	N/A
Environmental Conditions	N/A	Limits	Class <input type="checkbox"/> A <input type="checkbox"/> B <input type="checkbox"/> C <input type="checkbox"/> D
Test Mode	N/A	Tested by	N/A

NOTE: The subject equipment is not intended to be connected to AC mains supply. Therefore, this test is not applicable.

7.5. VOLTAGE FLUCTUATION AND FLICKS MEASUREMENT

7.5.1. LIMITS OF VOLTAGE FLUCTUATION AND FLICKS MEASUREMENT

Test Item	Limit	Remark
P_{st}	1.0	P_{st} means short-term flicker indicator.
P_{lt}	0.65	P_{lt} means long-term flicker indicator.
T_{dt} (ms)	500	T_{dt} means maximum time that dt exceeds 3.3 %.
d_{max} (%)	4%	d_{max} means maximum relative voltage change.
dc (%)	3.3%	dc means relative steady-state voltage change

7.5.2. TEST INSTRUMENTS

Name of Equipment	Manufacturer	Model	Serial Number	Calibration Due

NOTE: The calibration interval of the above test instruments is 12 months and the calibrations are traceable to NML/ROC and NIST/USA.

7.5.3. TEST PROCEDURE (please refer to measurement standard or CCS SOP PA-030)

- The EUT was placed on the top of a wooden table 0.8 meters above the ground and operated to produce the most unfavorable sequence of voltage changes under normal operating conditions.
- During the flick measurement, the measure time shall include that part of whole operation cycle in which the EUT produce the most unfavorable sequence of voltage changes. The observation period for short-term flicker indicator is 10 minutes and the observation period for long-term flicker indicator is 2 hours.

7.5.4. TEST SETUP

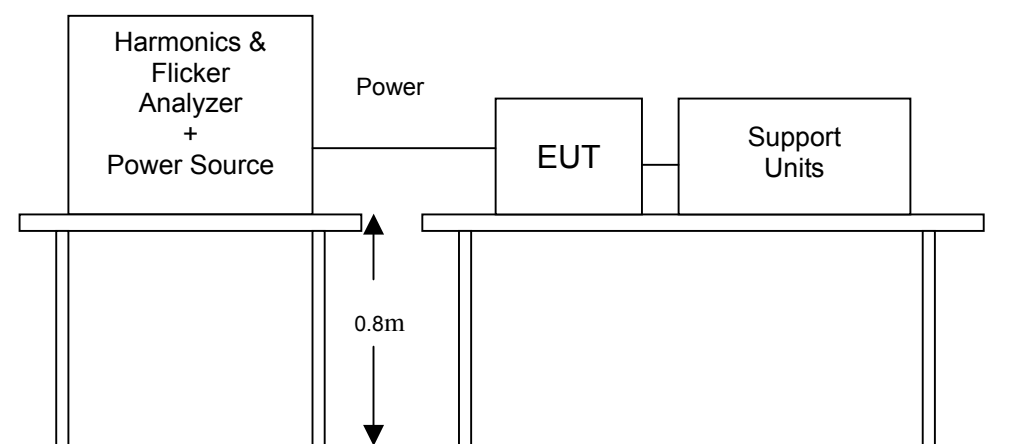

- For the actual test configuration, please refer to the related item – Photographs of the Test Configuration.

7.5.5. TEST RESULTS

Observation Period (Tp)	N/A	Test Mode	N/A
Environmental Conditions	N/A	Tested by	N/A

TEST PARAMETER	MEASUREMENT VALUE	LIMIT	REMARK
P_{st}	N/A	1.0	N/A
P_{lt}	N/A	0.65	N/A
T_{dt} (ms)	N/A	500	N/A
d_{max} (%)	N/A	4%	N/A
dc (%)	N/A	3.3%	N/A

Note: The subject equipment is not intended to be connected to AC mains supply. Therefore, this test is not applicable.

8 IMMUNITY TEST

8.1. GENERAL DESCRIPTION

Product Standard	ETSI EN 301 489-1 V1.9.2 2011	
	Test Type	Minimum Requirement
Basic Standard, Specification, and Performance Criterion required	EN 61000-4-2	Electrostatic Discharge - ESD: 8kV air discharge, 4kV Contact discharge, Performance Criterion TT&TR
	EN 61000-4-3	Radio-Frequency Electromagnetic Field Susceptibility Test - RS: 80 ~1000 MHz and 1400 ~ 2700MHz, 3V/m, 80% AM(1kHz), Performance Criterion CT&CR
	EN 61000-4-4	Electrical Fast Transient/Burst - EFT, AC Power Port: 1kV DC Power Port: 0.5kV Signal Ports and Telecommunication Ports: 0.5kV Performance Criterion TT&TR
	EN 61000-4-5	Surge Immunity Test: 1.2/50 μ s Open Circuit Voltage, 8 /20 μ s Short Circuit Current, AC Power Port ~ line to line: 1kV, line to earth (ground): 2kV DC Power Port ~ line to line and line to earth: 0.5kV Signal Ports and Telecommunication Ports ~ line to ground: 1kV Performance Criterion TT&TR
	EN 61000-4-6	Conducted Radio Frequency Disturbances Test - CS: 0.15 ~ 80 MHz, 3Vrms, 80% AM, 1kHz, 5 ~ 80 MHz, 3Vrms, 80% AM, 1kHz, Performance Criterion CT&CR
	EN 61000-4-11	Voltage Dips: 1) 0% residual 0.5 periods Performance CT or CR 2) 0% residual 1 periods Performance CT or CR 3) 70% residual 25 periods Performance CT or CR 4) 0% residual 250 periods Performance TT or TR 5) 30% reduction 0.5 periods Performance CT or CR 6) 60% reduction 5 periods Performance TT or TR 7) 0% reduction 250 periods Performance TT or TR

Performance table for EN 301 489-3		
Class 1 SRD equipment		
Criteria	During test	After test
A	Operate as intended No loss of function For equipment type II the minimum performance shall be 12 dB SINAD No unintentional responses	Operate as intended For equipment type II the communication link shall be maintained No loss of function No degradation of performance No loss of stored data or user programmable functions
B	May be loss of function (one or more) No unintentional responses	Operate as intended Lost function(s) shall be self-recoverable No degradation of performance No loss of stored data or user programmable functions
Class 2 SRD equipment		
Criteria	During test	After test
A	Operate as intended No loss of function For equipment type II the minimum performance shall be 6 dB SINAD No unintentional responses	Operate as intended For equipment type II the communication link shall be maintained No loss of function No degradation of performance No loss of stored data or user programmable functions
B	May be loss of function (one or more) No unintentional responses	Operate as intended Lost function(s) shall be self-recoverable No degradation of performance No loss of stored data or user programmable functions
Class 3 SRD equipment		
Criteria	During test	After test
A and B	May be loss of function (one or more) No unintentional responses	Operate as intended, for equipment type II the communication link may be lost, but shall be recoverable by user No degradation of performance Lost functions shall be self-recoverable

Performance criteria for Continuous phenomena applied to Transmitters (CT)

For equipment of type I or II including ancillary equipment tested on a stand alone basis, the performance criteria A of the applicable class as given in clause 6.3 shall apply.

For equipment of type II or type III that requires a communication link that is maintained during the test, it shall be verified by appropriate means supplied by the manufacturer that the communication link is maintained during each individual exposure in the test sequence.

Where the EUT is a transmitter, tests shall be repeated with the EUT in standby mode to ensure that any unintentional transmission does not occur.

Performance criteria for Transient phenomena applied to Transmitters (TT)

For equipment of type I or II, including ancillary equipment tested on a stand alone basis, the performance criteria B of the applicable class as given in clause 6.3 shall apply, except for power interruptions exceeding a certain time the performance criteria deviations are specified in clause 7.2.2.

For equipment of type II or type III that requires a communication link that is maintained during the test, this shall be verified by appropriate means supplied by the manufacturer during each individual exposure in the test sequence.

Where the EUT is a transmitter, tests shall be repeated with the EUT in standby mode to ensure that any unintentional transmission does not occur.

Performance criteria for Continuous phenomena applied to Receivers (CR)

For equipment of type I or II, including ancillary equipment tested on a stand alone basis, the performance criteria A of the applicable class as given in clause 6.3 shall apply.

For equipment of type II or III that requires a communication link that is maintained during the test, it shall be verified by appropriate means supplied by the manufacturer that the communication link is maintained during each individual exposure in the test sequence.

Where the EUT is a transceiver, under no circumstances shall the transmitter operate unintentionally during the test.

Performance criteria for Transient phenomena applied to Receivers (TR)

For equipment of type I or II, including ancillary equipment tested on a stand alone basis, the performance criteria B of the applicable class as given in clause 6.3 shall apply, except for power interruptions exceeding a certain time the performance criteria deviations are specified in clause 7.2.2.

For equipment of type II or type III that requires a communication link that is maintained during the test, this shall be verified by appropriate means supplied by the manufacturer during each individual exposure in the test sequence.

Where the EUT is a transceiver, under no circumstances shall the transmitter operate unintentionally during the test.

8.2. ELECTROSTATIC DISCHARGE (ESD)

8.2.1. TEST SPECIFICATION

Basic Standard:	EN 61000-4-2
Discharge Impedance:	330 ohm / 150 pF
Discharge Voltage:	Air Discharge: 2 ; 4 ; 8 kV (Direct) Contact Discharge: 2 ; 4 kV (Direct/Indirect)
Polarity:	Positive & Negative
Number of Discharge:	Minimum 10 times at each test point
Discharge Mode:	Single Discharge 1 second minimum

8.2.2. TEST INSTRUMENT

IMMUNITY SHIELDED ROOM				
Name of Equipment	Manufacturer	Model	Serial Number	Calibration Due
ESD Generator	Teseq	NSG 437	249	12/13/2016
Aneroid Barometer	Sato	7610-20	89090	10/15/2016
Thermo-Hygrometer	TECPEL	DTM-303	080269	04/19/2016

NOTE: The calibration interval of the above test instruments is 12 months and the calibrations are traceable to NML/ROC and NIST/USA.

8.2.3. TEST PROCEDURE (please refer to measurement standard or CCS SOP PA-022)

The discharges shall be applied in two ways:

a) Contact discharges to the conductive surfaces and coupling planes:

The EUT shall be exposed to at least 20 discharges, 10 each at negative and positive polarity, at a minimum of four test points. One of the test points shall be subjected to at least 10 indirect discharges to the center of the front edge of the Horizontal Coupling Plane (HCP). The remaining three test points shall each receive at least 10 direct contact discharges. If no direct contact test points are available, then at least 20 indirect discharges shall be applied in the indirect mode. Test shall be performed at a maximum repetition rate of one discharge per second.

b) Air discharges at slots and apertures and insulating surfaces:

On those parts of the EUT where it is not possible to perform contact discharge testing, the equipment should be investigated to identify user accessible points where breakdown may occur. Such points are tested using the air discharge method. This investigation should be restricted to those area normally handled by the user. A minimum of 10 single air discharges shall be applied to the selected test point for each such area.

The basic test procedure was in accordance with EN 61000-4-2:

- a) The EUT was located 0.1 m minimum from all side of the **HCP** (dimensions 1.6m x 0.8m).
- b) The support units were located another table 30 cm away from the EUT, but direct support unit was/were located at same location as EUT on the HCP and keep at a distance of 10 cm with EUT.
- c) The time interval between two successive single discharges was at least 1 second.
- d) Contact discharges were applied to the non-insulating coating, with the pointed tip of the generator penetrating the coating and contacting the conducting substrate.
- e) Air discharges were applied with the round discharge tip of the discharge electrode approaching the EUT as fast as possible (without causing mechanical damage) to touch the EUT. After each discharge, the ESD generator was removed from the EUT and re-triggered for a new single discharge. The test was repeated until all discharges were complete.
- f) At least ten single discharges (in the most sensitive polarity) were applied at the front edge of each **HCP** opposite the center point of each unit of the EUT and 0.1 meters from the front of the EUT. The long axis of the discharge electrode was in the plane of the **HCP** and perpendicular to its front edge during the discharge.
- g) At least ten single discharges (in the most sensitive polarity) were applied to the center of one vertical edge of the **Vertical Coupling Plane (VCP)** in sufficiently different positions that the four faces of the EUT were completely illuminated. The **VCP** (dimensions 0.5m x 0.5m) was placed vertically to and 0.1 meters from the EUT.

8.2.4. TEST SETUP

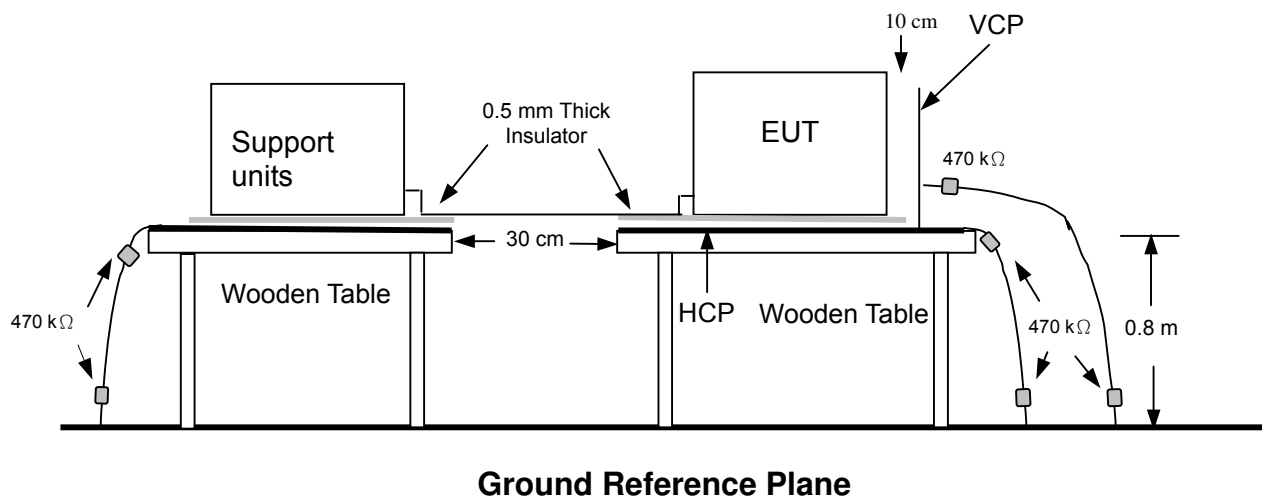

- For the actual test configuration, please refer to the related item – Photographs of the Test Configuration.

NOTE:

TABLE-TOP EQUIPMENT

The configuration consisted of a wooden table 0.8 meters high standing on the **Ground Reference Plane**. The **GRP** consisted of a sheet of aluminum at least 0.25mm thick, and 2.5 meters square connected to the protective grounding system. A **Horizontal Coupling Plane** (1.6m x 0.8m) was placed on the table and attached to the **GRP** by means of a cable with 940k total impedance. The equipment under test, was installed in a representative system as described in section 7 of EN 61000-4-2, and its cables were placed on the **HCP** and isolated by an insulating support of 0.5mm thickness. A distance of 1-meter minimum was provided between the EUT and the walls of the laboratory and any other metallic structure.

FLOOR-STANDING EQUIPMENT

The equipment under test was installed in a representative system as described in section 7 of EN 61000-4-2, and its cables were isolated from the Ground Reference Plane by an insulating support of 0.1-meter thickness. The GRP consisted of a sheet of aluminum that is at least 0.25mm thick, and 2.5 meters square connected to the protective grounding system and extended at least 0.5 meters from the EUT on all sides.

8.2.5. TEST RESULTS

Temperature	20°C	Humidity	43% RH
Pressure	1010mbar	Tested By	Bonny Tsai
Required Passing Performance		Criterion TT&TR	

Air Discharge							
Test Points	Test Levels			Results			
	± 2 KV	± 4 KV	± 8 KV	Pass	Fail	Performance Criterion	Observation
Front	<input checked="" type="checkbox"/>	<input checked="" type="checkbox"/>	<input checked="" type="checkbox"/>	<input checked="" type="checkbox"/>	<input type="checkbox"/>	<input checked="" type="checkbox"/> CT / <input checked="" type="checkbox"/> CR <input type="checkbox"/> TT / <input type="checkbox"/> TR	Note <input type="checkbox"/> 1 <input checked="" type="checkbox"/> 2
Back	<input checked="" type="checkbox"/>	<input checked="" type="checkbox"/>	<input checked="" type="checkbox"/>	<input checked="" type="checkbox"/>	<input type="checkbox"/>	<input checked="" type="checkbox"/> CT / <input checked="" type="checkbox"/> CR <input type="checkbox"/> TT / <input type="checkbox"/> TR	Note <input type="checkbox"/> 1 <input checked="" type="checkbox"/> 2
Left	<input checked="" type="checkbox"/>	<input checked="" type="checkbox"/>	<input checked="" type="checkbox"/>	<input checked="" type="checkbox"/>	<input type="checkbox"/>	<input checked="" type="checkbox"/> CT / <input checked="" type="checkbox"/> CR <input type="checkbox"/> TT / <input type="checkbox"/> TR	Note <input type="checkbox"/> 1 <input checked="" type="checkbox"/> 2
Right	<input checked="" type="checkbox"/>	<input checked="" type="checkbox"/>	<input checked="" type="checkbox"/>	<input checked="" type="checkbox"/>	<input type="checkbox"/>	<input checked="" type="checkbox"/> CT / <input checked="" type="checkbox"/> CR <input type="checkbox"/> TT / <input type="checkbox"/> TR	Note <input type="checkbox"/> 1 <input checked="" type="checkbox"/> 2
Top	<input checked="" type="checkbox"/>	<input checked="" type="checkbox"/>	<input checked="" type="checkbox"/>	<input checked="" type="checkbox"/>	<input type="checkbox"/>	<input checked="" type="checkbox"/> CT / <input checked="" type="checkbox"/> CR <input type="checkbox"/> TT / <input type="checkbox"/> TR	Note <input type="checkbox"/> 1 <input checked="" type="checkbox"/> 2

Contact Discharge							
Test Points	Test Levels			Results			
	± 2 kV	± 4 kV	± 8 kV	Pass	Fail	Performance Criterion	Observation
Front	<input checked="" type="checkbox"/>	<input checked="" type="checkbox"/>	<input type="checkbox"/>	<input checked="" type="checkbox"/>	<input type="checkbox"/>	<input checked="" type="checkbox"/> CT / <input checked="" type="checkbox"/> CR <input type="checkbox"/> TT / <input type="checkbox"/> TR	Note <input checked="" type="checkbox"/> 1 <input type="checkbox"/> 2
Back	<input checked="" type="checkbox"/>	<input checked="" type="checkbox"/>	<input type="checkbox"/>	<input checked="" type="checkbox"/>	<input type="checkbox"/>	<input checked="" type="checkbox"/> CT / <input checked="" type="checkbox"/> CR <input type="checkbox"/> TT / <input type="checkbox"/> TR	Note <input checked="" type="checkbox"/> 1 <input type="checkbox"/> 2

Discharge To Horizontal Coupling Plane							
Side of EUT	Test Levels			Results			
	± 2 KV	± 4 KV	± 8 KV	Pass	Fail	Performance Criterion	Observation
Front	<input checked="" type="checkbox"/>	<input checked="" type="checkbox"/>	<input type="checkbox"/>	<input checked="" type="checkbox"/>	<input type="checkbox"/>	<input checked="" type="checkbox"/> CT / <input checked="" type="checkbox"/> CR <input type="checkbox"/> TT / <input type="checkbox"/> TR	Note <input checked="" type="checkbox"/> 1 <input type="checkbox"/> 2
Back	<input checked="" type="checkbox"/>	<input checked="" type="checkbox"/>	<input type="checkbox"/>	<input checked="" type="checkbox"/>	<input type="checkbox"/>	<input checked="" type="checkbox"/> CT / <input checked="" type="checkbox"/> CR <input type="checkbox"/> TT / <input type="checkbox"/> TR	Note <input checked="" type="checkbox"/> 1 <input type="checkbox"/> 2
Left	<input checked="" type="checkbox"/>	<input checked="" type="checkbox"/>	<input type="checkbox"/>	<input checked="" type="checkbox"/>	<input type="checkbox"/>	<input checked="" type="checkbox"/> CT / <input checked="" type="checkbox"/> CR <input type="checkbox"/> TT / <input type="checkbox"/> TR	Note <input checked="" type="checkbox"/> 1 <input type="checkbox"/> 2
Right	<input checked="" type="checkbox"/>	<input checked="" type="checkbox"/>	<input type="checkbox"/>	<input checked="" type="checkbox"/>	<input type="checkbox"/>	<input checked="" type="checkbox"/> CT / <input checked="" type="checkbox"/> CR <input type="checkbox"/> TT / <input type="checkbox"/> TR	Note <input checked="" type="checkbox"/> 1 <input type="checkbox"/> 2

Discharge To Vertical Coupling Plane							
Side of EUT	Test Levels			Results			
	± 2 KV	± 4 KV	± 8 KV	Pass	Fail	Performance Criterion	Observation
Front	<input checked="" type="checkbox"/>	<input checked="" type="checkbox"/>	<input type="checkbox"/>	<input checked="" type="checkbox"/>	<input type="checkbox"/>	<input checked="" type="checkbox"/> CT / <input checked="" type="checkbox"/> CR <input type="checkbox"/> TT / <input type="checkbox"/> TR	Note <input checked="" type="checkbox"/> 1 <input type="checkbox"/> 2
Back	<input checked="" type="checkbox"/>	<input checked="" type="checkbox"/>	<input type="checkbox"/>	<input checked="" type="checkbox"/>	<input type="checkbox"/>	<input checked="" type="checkbox"/> CT / <input checked="" type="checkbox"/> CR <input type="checkbox"/> TT / <input type="checkbox"/> TR	Note <input checked="" type="checkbox"/> 1 <input type="checkbox"/> 2
Left	<input checked="" type="checkbox"/>	<input checked="" type="checkbox"/>	<input type="checkbox"/>	<input checked="" type="checkbox"/>	<input type="checkbox"/>	<input checked="" type="checkbox"/> CT / <input checked="" type="checkbox"/> CR <input type="checkbox"/> TT / <input type="checkbox"/> TR	Note <input checked="" type="checkbox"/> 1 <input type="checkbox"/> 2
Right	<input checked="" type="checkbox"/>	<input checked="" type="checkbox"/>	<input type="checkbox"/>	<input checked="" type="checkbox"/>	<input type="checkbox"/>	<input checked="" type="checkbox"/> CT / <input checked="" type="checkbox"/> CR <input type="checkbox"/> TT / <input type="checkbox"/> TR	Note <input checked="" type="checkbox"/> 1 <input type="checkbox"/> 2

NOTE: 1. There was no change compared with initial operation during the test.
 2. No discharge point.

**The Photo for Discharge Points of EUT
Front**

T160222W01



Back

T160222W01



Red Dot —Air Discharged
Blue Dot —Contact Discharged

8.3. RADIATED, RADIO-FREQUENCY, ELECTROMAGNETIC FIELD (RS)

8.3.1. TEST SPECIFICATION

Basic Standard:	EN 61000-4-3
Frequency Range:	80 MHz ~1000 MHz, 1400 MHz ~ 2700 MHz
Field Strength:	3 V/m
Modulation:	1kHz Sine Wave, 80%, AM Modulation
Frequency Step:	1 % of preceding frequency value
Polarity of Antenna:	Horizontal and Vertical
Test Distance:	3 m
Antenna Height:	1.5m

8.3.2. TEST INSTRUMENT

RS Chamber				
Name of Equipment	Manufacturer	Model	Serial Number	Calibration Due
Calibration of Field	N/A	Chamber#RS	80-1000MHz	04/01/2016
Signal Generator	Agilent	N5181A	MY47421336	12/10/2016
Electric Field Probe	AR	FL7006	0338955	06/14/2016
RF Power Meter	Boonton	4242-01-02	14357	03/09/2017
Amplifier	AR	500W1000A	320994	No Calibration Required
Direction Coupler	AR	DC6180A	312189	No Calibration Required
Broadband Antenna	AR	AT1080	311819	No Calibration Required
Calibration of Field	N/A	Chamber#RS	80-1000MHz	04/01/2016
Calibration of Field	N/A	Chamber#RS	1000-6000MHz	06/21/2016
Amplifier	AR	50S1G6M1	0343693	No Cal. Required
Horn Antenna	EMCO	3115	5761	No Cal. Required
Direction Coupler	AR	DC7200	0343647	No Cal. Required
Test S/W	Emcware Ver. 2.6.0.16			

NOTE: 1. The calibration interval of the above test instruments is 12 months and the calibrations are traceable to NML/ROC and NIST/USA.
 2. N.C.R. = No Calibration Request.

8.3.3. TEST PROCEDURE (please refer to measurement standard or CCS SOP PA-023)

The test procedure was in accordance with EN 61000-4-3

- a) The testing was performed in a fully anechoic chamber. The transmit antenna was located at a distance of 3 meters from the EUT.
- b) The frequency range is swept from 80 MHz to 1000 MHz / 1400 MHz to 2700 MHz, with the signal 80% amplitude modulated with a 1kHz sine-wave. The rate of sweep did not exceed 1.5×10^{-3} decade/s, where the frequency range is swept incrementally, the step size was 1% of preceding frequency value.
- c) The dwell time at each frequency shall be not less than the time necessary for the EUT to be able to respond.
- d) The field strength level was 3V/m.
- e) The test was performed with the EUT exposed to both vertically and horizontally polarized fields on each of the four sides.

8.3.4. TEST SETUP

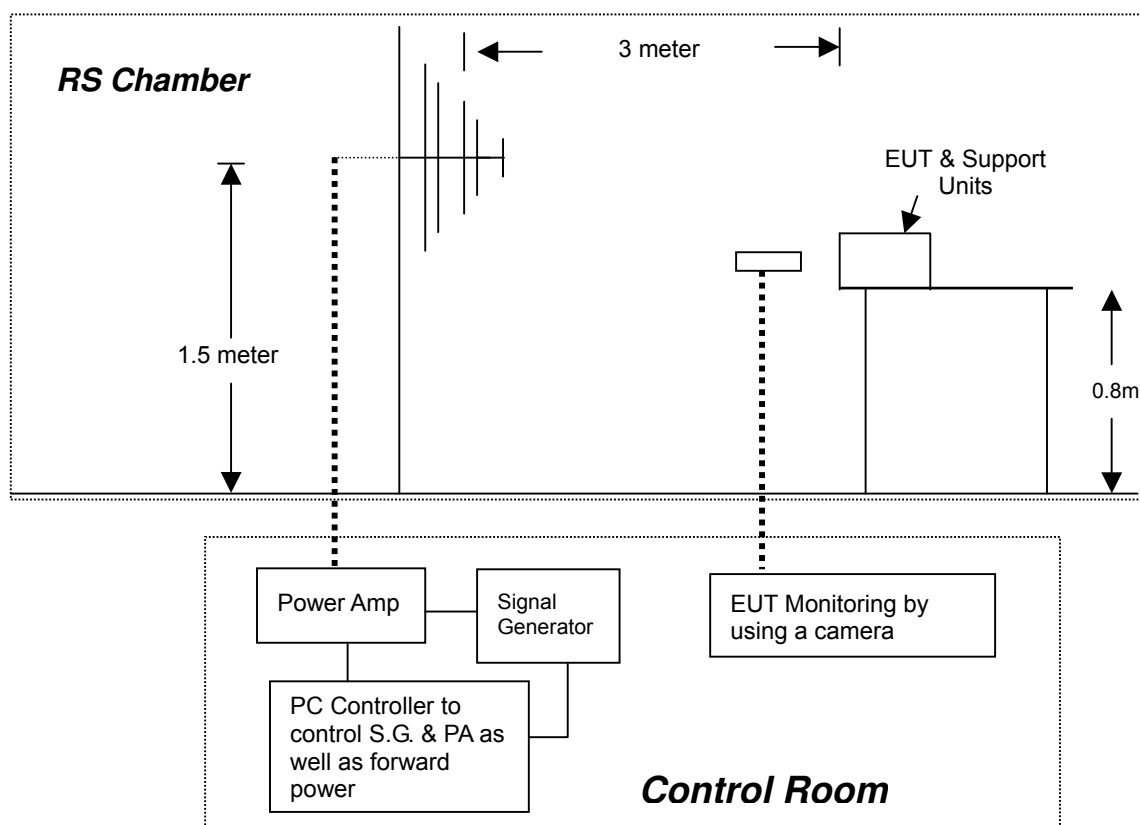

- For the actual test configuration, please refer to the related item – Photographs of the Test Configuration.

NOTE:

TABLETOP EQUIPMENT

The EUT installed in a representative system as described in section 7 of EN 61000-4-3 was placed on a non-conductive table 0.8 meters in height. The system under test was connected to the power and signal wire according to relevant installation instructions.

FLOOR STANDING EQUIPMENT

The EUT installed in a representative system as described in section 7 of EN 61000-4-3 was placed on a non-conductive wood support 0.1 meters in height. The system under test was connected to the power and signal wire according to relevant installation instructions.

8.3.5. TEST RESULTS

Temperature	23°C	Humidity	60% RH
Pressure	1010mbar	Dwell Time	3 sec.
Tested By	Bonny Tsai	Required Passing Performance	Criterion CT&CR

Frequency (MHz)	Polarity	Azimuth	Field Strength (V/m)	Performance Criterion	Observation	Result
80 ~ 1000	V&H	0	3	<input checked="" type="checkbox"/> CT <input checked="" type="checkbox"/> CR	Note <input checked="" type="checkbox"/> 1 <input type="checkbox"/> 2	PASS
80 ~ 1000	V&H	90	3	<input checked="" type="checkbox"/> CT <input checked="" type="checkbox"/> CR	Note <input checked="" type="checkbox"/> 1 <input type="checkbox"/> 2	PASS
80 ~ 1000	V&H	180	3	<input checked="" type="checkbox"/> CT <input checked="" type="checkbox"/> CR	Note <input checked="" type="checkbox"/> 1 <input type="checkbox"/> 2	PASS
80 ~ 1000	V&H	270	3	<input checked="" type="checkbox"/> CT <input checked="" type="checkbox"/> CR	Note <input checked="" type="checkbox"/> 1 <input type="checkbox"/> 2	PASS
1400 ~ 2700	V&H	0	3	<input checked="" type="checkbox"/> CT <input checked="" type="checkbox"/> CR	Note <input checked="" type="checkbox"/> 1 <input type="checkbox"/> 2	PASS
1400 ~ 2700	V&H	90	3	<input checked="" type="checkbox"/> CT <input checked="" type="checkbox"/> CR	Note <input checked="" type="checkbox"/> 1 <input type="checkbox"/> 2	PASS
1400 ~ 2700	V&H	180	3	<input checked="" type="checkbox"/> CT <input checked="" type="checkbox"/> CR	Note <input checked="" type="checkbox"/> 1 <input type="checkbox"/> 2	PASS
1400 ~ 2700	V&H	270	3	<input checked="" type="checkbox"/> CT <input checked="" type="checkbox"/> CR	Note <input checked="" type="checkbox"/> 1 <input type="checkbox"/> 2	PASS

Note: 1. There was no change compared with initial operation during the test.

8.4. ELECTRICAL FAST TRANSIENT (EFT)

8.4.1. TEST SPECIFICATION

Basic Standard:	EN 61000-4-4
Test Voltage:	DC Power Port: 0.5kV Signal Ports and Telecommunication Ports: 0.5kV
Polarity:	Positive & Negative
Impulse Frequency:	5 kHz
Impulse Wave-shape:	5/50 ns
Burst Duration:	15 ms
Burst Period:	300 ms
Test Duration:	Not less than 1 min.

8.4.2. TEST INSTRUMENT

Immunity Shield Room				
Name of Equipment	Manufacturer	Model	Serial Number	Calibration Due
EMC Immunity Tester	EMC Partner	TRANSIENT 2000	1117	03/10/2017
Capacitive Clamp	EMC-Partner	CN-EFT1000	589	07/21/2016
Test S/W	Genecs Ver. 3.27			

NOTE: 1. The calibration interval of the above test instruments is 12 months and the calibrations are traceable to NML/ROC and NIST/USA.
2. N.C.R. = No Calibration Request.

8.4.3. TEST PROCEDURE (please refer to measurement standard or CCS SOP PA-024)

- a) All types of cables, including their length, and the interface port of the EUT to which they were connected.
- b) Both positive and negative polarity discharges were applied.
- c) The length of the “hot wire” from the coaxial output of the EFT generator to the terminals on the EUT should not exceed 0.5 meter.
- d) The duration time of each test sequential was 1 minute.
- e) The transient/burst waveform was in accordance with EN 61000-4-4, 5/50ns.

8.4.4. TEST SETUP

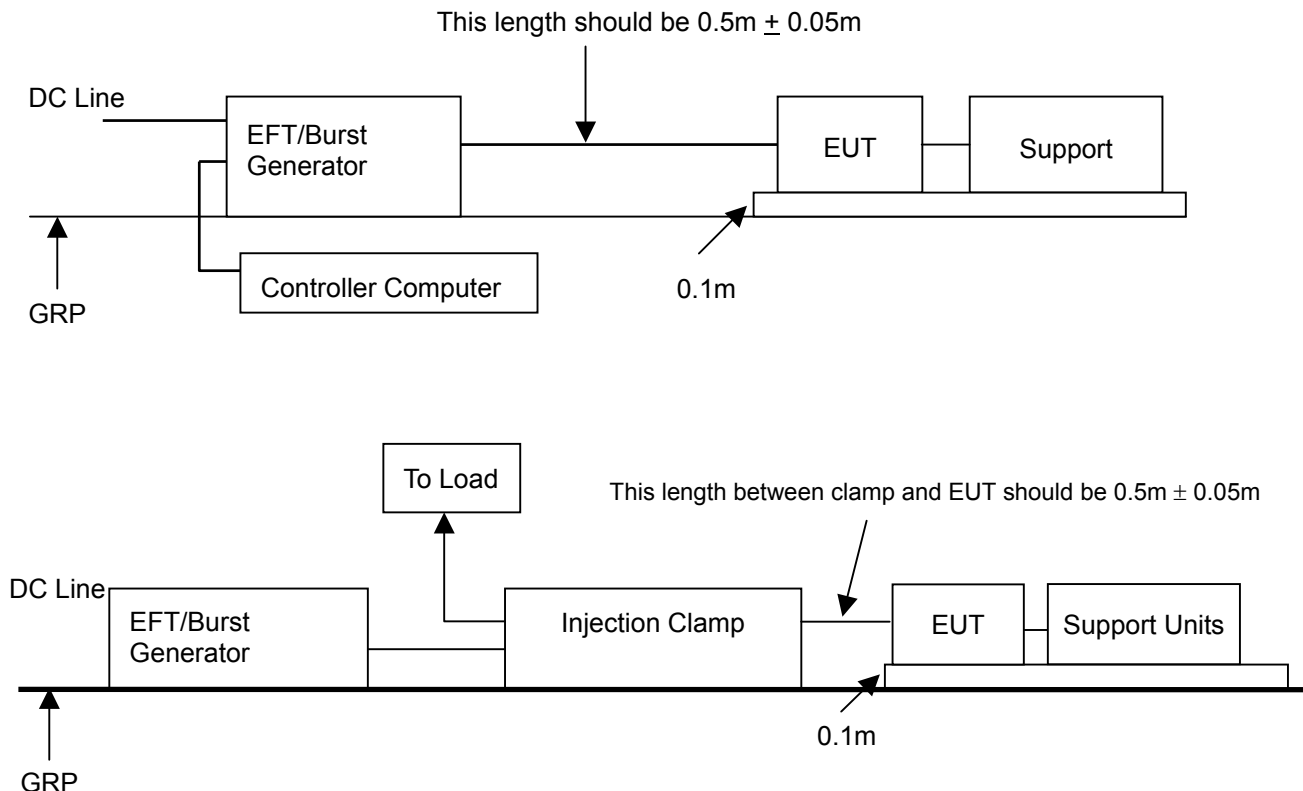

- For the actual test configuration, please refer to the related item - Photographs of the Test Configuration.

NOTE:

TABLETOP EQUIPMENT

The configuration consisted of a wooden table (0.8m high) standing on the Ground Reference Plane. The GRP consisted of a sheet of aluminum (at least 0.25mm thick and 2.5m square) connected to the protective grounding system. A minimum distance of 0.5m was provided between the EUT and the walls of the laboratory or any other metallic structure.

FLOOR STANDING EQUIPMENT

The EUT installed in a representative system as described in section 7 of EN 61000-4-4 and its cables, were isolated from the Ground Reference Plane by an insulating support that is 0.1-meter thick. The GRP consisted of a sheet of aluminum (at least 0.25mm thick and 2.5m square) connected to the protective grounding system.

8.4.5. TEST RESULTS

Temperature	20°C	Humidity	50% RH
Pressure	1010mbar	Tested By	Bonny Tsai
Required Passing Performance		Criterion TT&TR	

Test Point	Polarity	Test Level (kV)	Performance Criterion	Observation	Result
L	+/-	0.5	<input checked="" type="checkbox"/> CT / <input checked="" type="checkbox"/> CR <input type="checkbox"/> TT / <input type="checkbox"/> TR	Note <input checked="" type="checkbox"/> 1 <input type="checkbox"/> 2	PASS
N	+/-	0.5	<input checked="" type="checkbox"/> CT / <input checked="" type="checkbox"/> CR <input type="checkbox"/> TT / <input type="checkbox"/> TR	Note <input checked="" type="checkbox"/> 1 <input type="checkbox"/> 2	PASS
L - N	+/-	0.5	<input checked="" type="checkbox"/> CT / <input checked="" type="checkbox"/> CR <input type="checkbox"/> TT / <input type="checkbox"/> TR	Note <input checked="" type="checkbox"/> 1 <input type="checkbox"/> 2	PASS
Antenna	+/-	0.5	<input checked="" type="checkbox"/> CT / <input checked="" type="checkbox"/> CR <input type="checkbox"/> TT / <input type="checkbox"/> TR	Note <input checked="" type="checkbox"/> 1 <input type="checkbox"/> 2	PASS

Note: 1. There was no change compared with initial operation during the test.

8.5. SURGE IMMUNITY TEST

8.5.1. TEST SPECIFICATION

Basic Standard:	EN 61000-4-5
Wave-Shape:	Combination Wave 1.2/50 μ s Open Circuit Voltage 8/20 μ s Short Circuit Current
Test Voltage:	AC Power Port~ line to line: 1kV; line to earth: 2kV
Surge Input/Output:	AC Power Line: L-N / L-PE / N-PE
Generator Source Impedance:	2 ohm between networks 12 ohm between network and ground
Polarity:	Positive/Negative
Phase Angle:	0° / 90° / 180° / 270°
Pulse Repetition Rate:	1 time / min. (maximum)
Number of Tests:	5 positive and 5 negative at selected points

8.5.2. TEST INSTRUMENT

Immunity Shield Room				
Name of Equipment	Manufacturer	Model	Serial Number	Calibration Due

Note: 1. The calibration interval of the above test instruments is 12 months and the calibrations are traceable to NML/ROC and NIST/USA.
2. N.C.R. = No Calibration Request.

8.5.3. TEST PROCEDURE (please refer to measurement standard or CCS SOP PA-025)

- a) For EUT power supply:
The surge is applied to the EUT power supply terminals via the capacitive coupling network. Decoupling networks are required in order to avoid possible adverse effects on equipment not under test that may be powered by the same lines, and to provide sufficient decoupling impedance to the surge wave. The power cord between the EUT and the coupling/decoupling networks was shorter than 2 meters in length.
- b) For test applied to unshielded un-symmetrically operated interconnection lines of EUT:
The surge was applied to the lines via the capacitive coupling. The coupling / decoupling networks didn't influence the specified functional conditions of the EUT. The interconnection line between the EUT and the coupling/decoupling networks was shorter than 2 meters in length.
- c) For test applied to unshielded symmetrically operated interconnection / telecommunication lines of EUT:
The surge was applied to the lines via gas arrestors coupling. Test levels below the ignition point of the coupling arrestor were not specified. The interconnection line between the EUT and the coupling/decoupling networks was shorter than 2 meters in length.

8.5.4. TEST SETUP

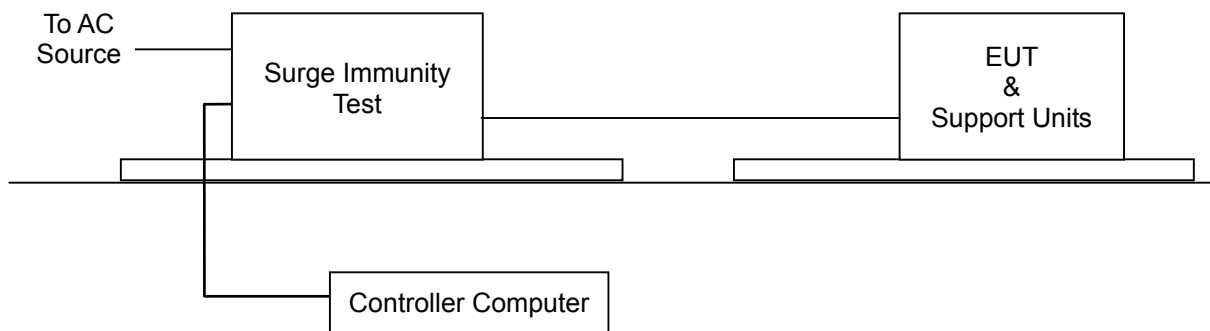

- For the actual test configuration, please refer to the related item - Photographs of the Test Configuration.

8.5.5. TEST RESULTS

Temperature	N/A	Humidity	N/A
Pressure	N/A	Tested by	N/A
Required Passing Performance		Criterion TT&TR	

Test Point	Polarity	Test Level (kV)	Performance Criterion	Observation	Result
L - N	+/-	1	<input type="checkbox"/> CT / <input type="checkbox"/> CR <input type="checkbox"/> TT / <input type="checkbox"/> TR	Note <input checked="" type="checkbox"/> 1 <input type="checkbox"/> 2	N/A
L - PE	+/-	2	<input type="checkbox"/> CT / <input type="checkbox"/> CR <input type="checkbox"/> TT / <input type="checkbox"/> TR	Note <input checked="" type="checkbox"/> 1 <input type="checkbox"/> 2	N/A
N - PE	+/-	2	<input type="checkbox"/> CT / <input type="checkbox"/> CR <input type="checkbox"/> TT / <input type="checkbox"/> TR	Note <input checked="" type="checkbox"/> 1 <input type="checkbox"/> 2	N/A

Note: 1. The subject equipment is not intended to be connected to AC mains supply. Therefore, this test is not applicable.

8.6. CONDUCTED RADIO FREQUENCY DISTURBANCES (CS)

8.6.1. TEST SPECIFICATION

Basic Standard:	EN 61000-4-6
Frequency Range:	0.15 MHz ~ 80 MHz; 5 MHz ~ 80 MHz
Field Strength:	3 Vrms
Modulation:	1kHz Sine Wave, 80%, AM Modulation
Frequency Step:	1 % of preceding frequency value
Coupled cable:	Power Mains, Unshielded Antenna Line, Unshielded
Coupling device:	<input checked="" type="checkbox"/> CDN-M2 (2 wires) <input type="checkbox"/> CDN-M3 (3 wires) <input type="checkbox"/> CDN-T2 for Line <input type="checkbox"/> CDN-T4/T8 for RJ45 <input checked="" type="checkbox"/> EM-Clamp

8.6.2. TEST INSTRUMENT

CS Room				
Name of Equipment	Manufacturer	Model	Serial Number	Calibration Due
CWS Generator	EM Test	CWS 500N1.4	P1446143188	02/21/2017
CDN (EUT)	Teseq	CDN M016	35820	06/15/2016
CDN	Teseq	CDN M016	35821	06/08/2016
EM Clamp	Schaffner	KEMZ 801	19227	02/22/2017
Attenuator	EMCI	SA3NL	10006F	No Calibration Required
Test S/W	icd.control Ver. 5.1.9			

- NOTE:** 1. The calibration interval of the above test instruments is 12 months and the calibrations are traceable to NML/ROC and NIST/USA.
 2. N.C.R. = No Calibration Request.

8.6.3. TEST PROCEDURE (please refer to measurement standard or CCS SOP PA-026)

The EUT shall be tested within its intended operating and climatic conditions.

The test shell performed with the test generator connected to each of the coupling and decoupling devices in turn, while the other non-excited RF input ports of the coupling devices are terminated by a 50-ohm load resistor.

The frequency range was swept from 150 kHz to 80 MHz, using the signal level established during the setting process and with a disturbance signal of 80 % amplitude. The signal was modulated with a 1 kHz sine wave, pausing to adjust the RF signal level or the switch coupling devices as necessary. The sweep rate was 1.5×10^{-3} decades/s. Where the frequency range is swept incrementally, the step size was 1 % of preceding frequency value from 150 kHz to 80 MHz.

The dwell time at each frequency was less than the time necessary for the EUT to be exercised, and able to respond. Sensitive frequencies such as clock frequency(ies) and harmonics or frequencies of dominant interest, was analyzed separately.

Attempts was made to fully exercise the EUT during testing, and to fully interrogate all exercise modes selected for susceptibility.

8.6.4. TEST SETUP

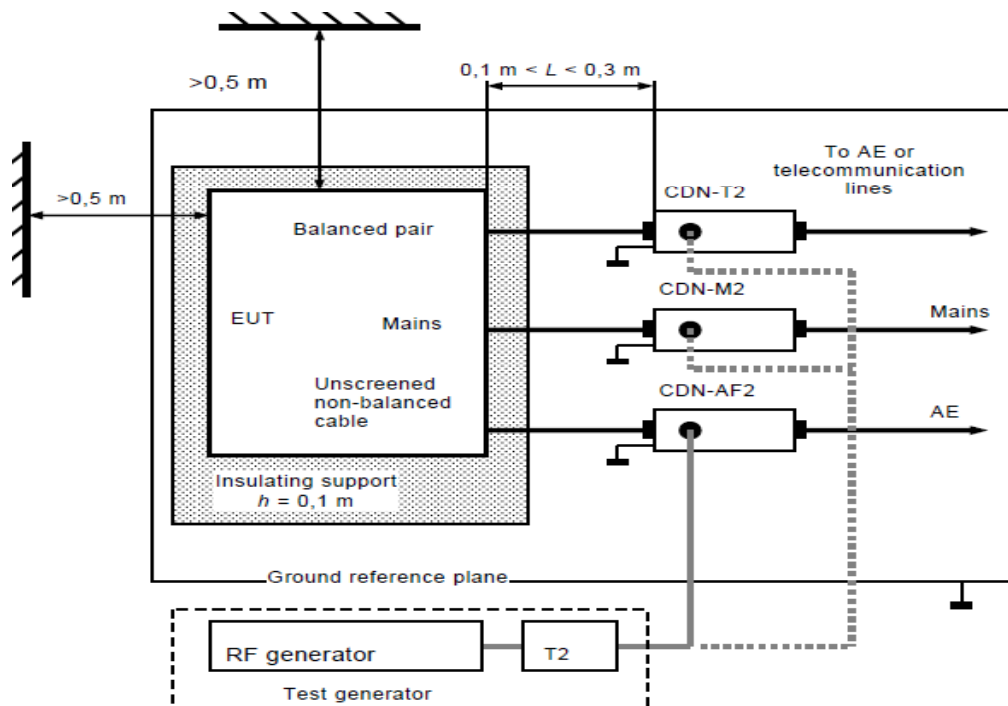

Note: 1. The CDNs and / or EM clamp used for real test depends on ports and cables configuration of EUT.
 2. The EUT clearance from any metallic obstacles shall be at least 0.5m.

- For the actual test configuration, please refer to the related item – Photographs of the Test Configuration.

NOTE:

TABLE-TOP AND FLOOR-STANDING EQUIPMENT

The equipment to be tested was placed on an insulating support of 0.1 meters height above a ground reference plane. All relevant cables shall be provided with the appropriate coupling and decoupling devices at a distance between 0.1 meters and 0.3 meters from the projected geometry of the EUT on the ground reference plane.

8.6.5. TEST RESULTS

Temperature	21°C	Humidity	50% RH
Pressure	1009mbar	Tested By	Bonny Tsai
Required Passing Performance		Criterion CT&CR	

Frequency Band (MHz)	Field Strength (Vrms)	Cable	Injection Method	Performance Criterion	Observation	Result
0.15 ~ 80	3	DC Power Line (0.3m)	CDN-M2	<input checked="" type="checkbox"/> CT <input checked="" type="checkbox"/> CR	Note <input checked="" type="checkbox"/> 1 <input type="checkbox"/> 2	PASS
5 ~ 80	3	DC Power Line (0.3m)	CDN-M2	<input checked="" type="checkbox"/> CT <input checked="" type="checkbox"/> CR	Note <input checked="" type="checkbox"/> 1 <input type="checkbox"/> 2	PASS
0.15 ~ 80	3	Antenna Line (0.3m)	EM-Clamp	<input checked="" type="checkbox"/> CT <input checked="" type="checkbox"/> CR	Note <input checked="" type="checkbox"/> 1 <input type="checkbox"/> 2	PASS
5 ~ 80	3	Antenna Line (0.3m)	EM-Clamp	<input checked="" type="checkbox"/> CT <input checked="" type="checkbox"/> CR	Note <input checked="" type="checkbox"/> 1 <input type="checkbox"/> 2	PASS

Note: 1. There was no change compared with initial operation during the test.

8.7. VOLTAGE DIP & VOLTAGE INTERRUPTIONS

8.7.1. TEST SPECIFICATION

Basic Standard:	EN 61000-4-11
Test duration time:	Minimum three test events in sequence
Interval between event:	Minimum 10 seconds
Angle:	0~360 degree
Step:	45 degree

8.7.2. TEST INSTRUMENT

Immunity shielded room				
Name of Equipment	Manufacturer	Model	Serial Number	Calibration Due

Note: 1. The calibration interval of the above test instruments is 12 months and the calibrations are traceable to NML/ROC and NIST/USA.

8.7.3. TEST PROCEDURE (please refer to measurement standard or CCS SOP PA-028)

1. The EUT and support units were located on a wooden table, 0.1 m away from ground floor.
2. Setting the parameter of tests and then perform the test software of test simulator.
3. Conditions changes to occur at 0 degree crossover point of the voltage waveform.
4. Recording the test result in test record form.

8.7.4. TEST SETUP

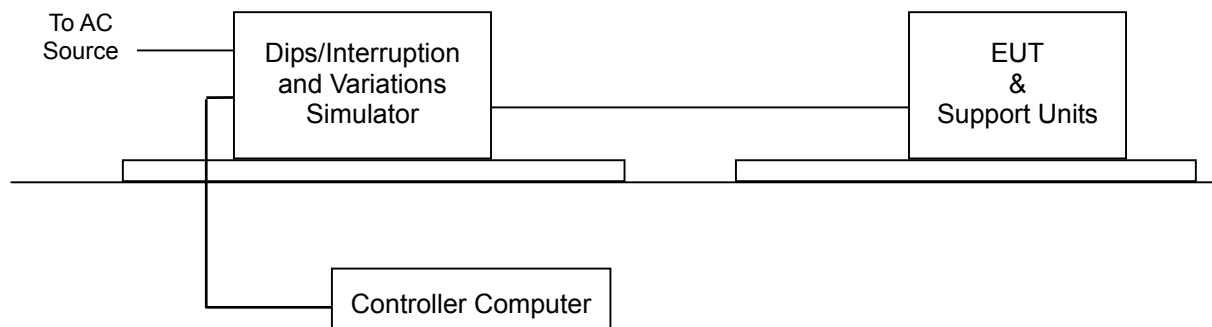

- For the actual test configuration, please refer to the related item – Photographs of the Test Configuration.

8.7.5. TEST RESULTS

Temperature	N/A	Humidity	N/A
Pressure	N/A	Tested by	N/A
Required Passing Performance	CT or CR: 0% residual 0.5 periods 0% residual 1 periods 70% residual 25 periods TT or TR: 0% residual 250 periods CT or CR: 30% reduction 0.5 periods 60% reduction 5 periods TT or TR: 0% reduction 250 periods		

Test Power: 230Vac, 50Hz				
Voltage (% Residual or Reduction)	Duration (Period)	Performance Criterion	Observation	Test Result
0	0.5	<input type="checkbox"/> CT / <input type="checkbox"/> CR <input type="checkbox"/> TT / <input type="checkbox"/> TR	Note <input checked="" type="checkbox"/> 1 <input type="checkbox"/> 2	N/A
0	1	<input type="checkbox"/> CT / <input type="checkbox"/> CR <input type="checkbox"/> TT / <input type="checkbox"/> TR	Note <input checked="" type="checkbox"/> 1 <input type="checkbox"/> 2	N/A
70	25	<input type="checkbox"/> CT / <input type="checkbox"/> CR <input type="checkbox"/> TT / <input type="checkbox"/> TR	Note <input checked="" type="checkbox"/> 1 <input type="checkbox"/> 2	N/A
0	250	<input type="checkbox"/> CT / <input type="checkbox"/> CR <input type="checkbox"/> TT / <input type="checkbox"/> TR	Note <input checked="" type="checkbox"/> 1 <input type="checkbox"/> 2	N/A
30%	0.5	<input type="checkbox"/> CT / <input type="checkbox"/> CR <input type="checkbox"/> TT / <input type="checkbox"/> TR	Note <input checked="" type="checkbox"/> 1 <input type="checkbox"/> 2	N/A
60%	5	<input type="checkbox"/> CT / <input type="checkbox"/> CR <input type="checkbox"/> TT / <input type="checkbox"/> TR	Note <input checked="" type="checkbox"/> 1 <input type="checkbox"/> 2	N/A
>95%	250	<input type="checkbox"/> CT / <input type="checkbox"/> CR <input type="checkbox"/> TT / <input type="checkbox"/> TR	Note <input checked="" type="checkbox"/> 1 <input type="checkbox"/> 2	N/A

NOTE: 1. The subject equipment is not intended to be connected to AC mains supply. Therefore, this test is not applicable.

9 PHOTOGRAPHS OF THE TEST CONFIGURATION

RADIATED EMISSION TEST



ESD Test



RS Test

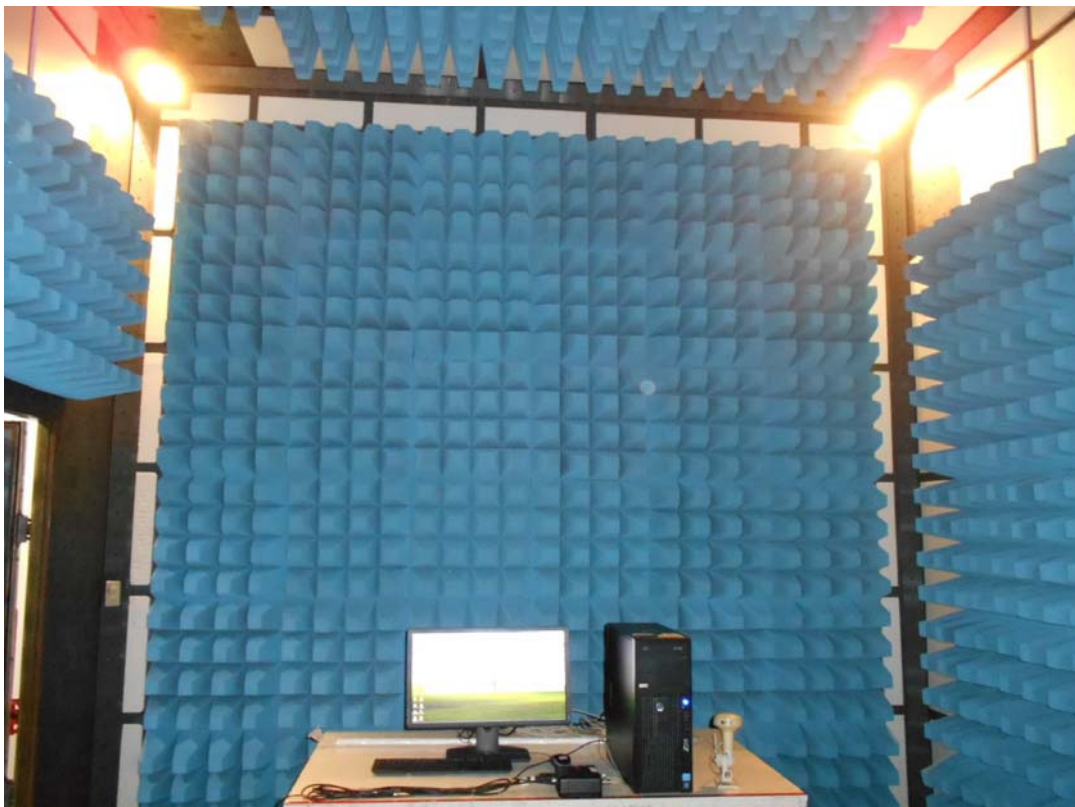

EFT Test

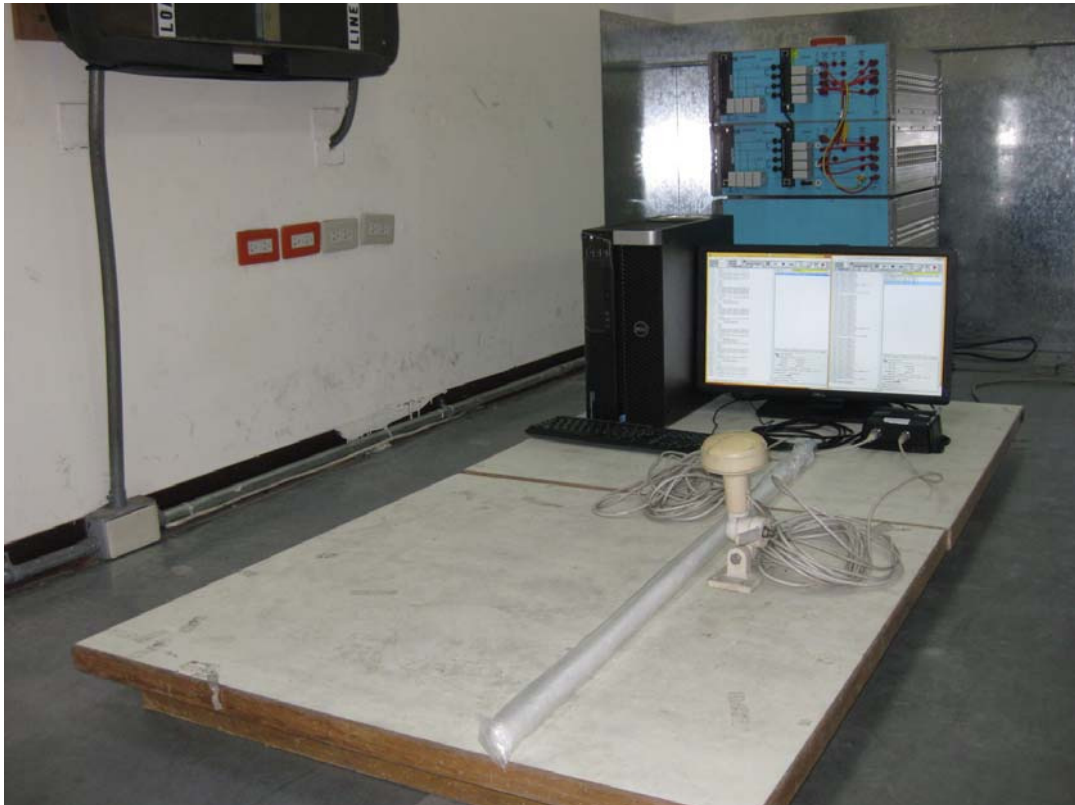

EFT For I/O Test



CS Test

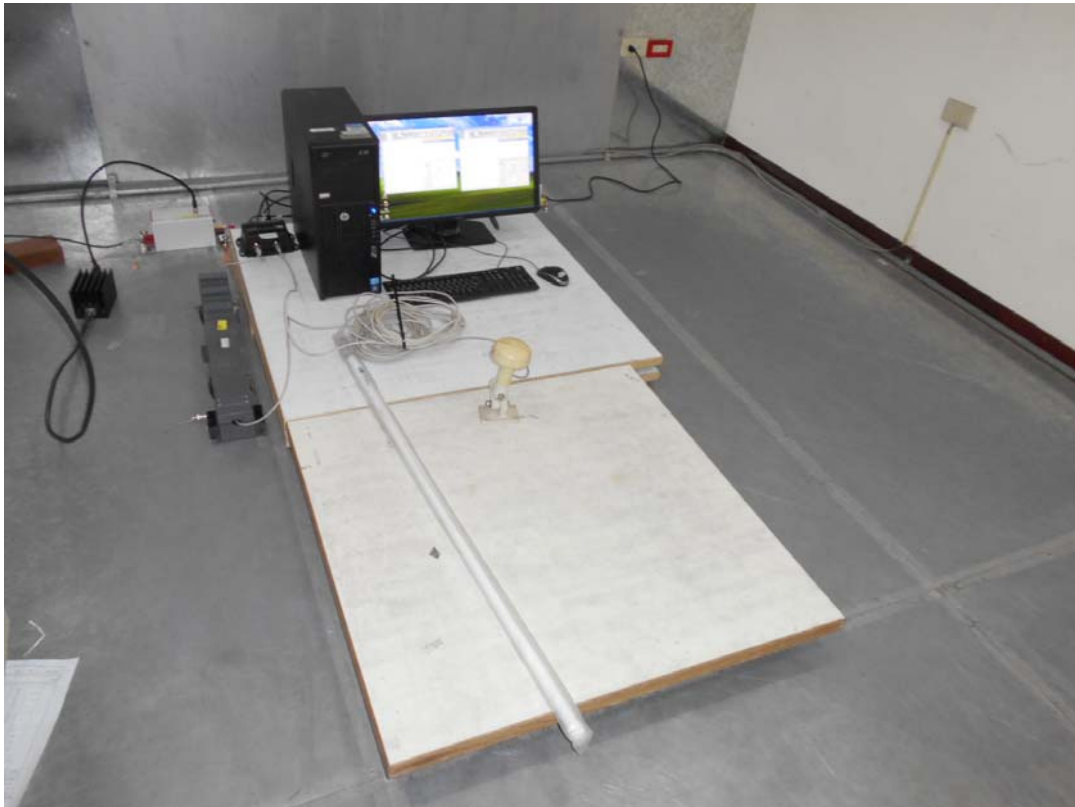

CS For I/O Test

