

EMC

Test Report

Product Name : AIS Class B Transponder
Model No. : CAMINO-108, CAMINO-108W

Applicant : Alltek Marine Electronics Corp.

Address : 7F, No.605, Ruei Guang Rd., Neihu, Taipei, Taiwan, 114 R.O.C.

Date of Receipt : 2013/05/06
Issued Date : 2013/10/21
Report No. : 135096R-ITCEP26V01
Report Version : V2.0

The test results relate only to the samples tested.

The test results shown in the test report are traceable to the national/international standard through the calibration of the equipment and evaluated measurement uncertainty herein.

This report must not be used to claim product endorsement by TAF or any agency of the Government.

The test report shall not be reproduced except in full without the written approval of Quietek Corporation.

Test Report Certification

Issued Date : 2013/10/21

Report No. : 135096R-ITCEP26V01

Quietek

Product Name : AIS Class B Transponder

Applicant : Alltek Marine Electronics Corp.

Address : 7F, No.605, Ruei Guang Rd., Neihu, Taipei, Taiwan, 114 R.O.C.

Manufacturer : Alltek Marine Electronics Corp.

Model No. : CAMINO-108, CAMINO-108W

EUT Rated Voltage : DC 9.6 ~ 31.2V

EUT Test Voltage : DC 12 / 24V

Trade Name : AMEC

Applicable Standard : IEC 60945: 2002-08 Chapter 9 and Chapter 10
IEC 60945: 2002 12.2

Test Result : Complied

Performed Location : Quietek Corporation (Linkou Laboratory)
No. 5-22, Rueishu Keng, Linkou Dist., New Taipei City 24451,
Taiwan. R.O.C.
TEL:+866-2-8601-3788 / FAX:+886-2-8601-3789

Documented By : Anny Chou
(Adm. Specialist / Anny Chou)

Reviewed By : Wright Tsai
(Assistant Engineer / Wright Tsai)

Approved By : Vincent Lin
(Manager / Vincent Lin)

Laboratory Information

We, **Quietek Corporation**, are an independent EMC and safety consultancy that was established the whole facility in our laboratories. The test facility has been accredited/accepted (audited or listed) by the following related bodies in compliance with ISO 17025, EN 45001 and specified testing scopes:

Taiwan R.O.C.	:	BSMI, NCC, TAF
Norway	:	Nemko, DNV
USA	:	FCC
Japan	:	VCCI

The related certificate for our laboratories about the test site and management system can be downloaded from Quietek Corporation's Web Site : <http://www.quietek.com/tw/ctg/cts/accreditations.htm>

The address and introduction of Quietek Corporation's laboratories can be founded in our Web site : <http://www.quietek.com/>

If you have any comments, Please don't hesitate to contact us. Our contact information is as below:

HsinChu Testing Laboratory :

No.75-2, 3rd Lin, Wangye Keng, Yonghxing Tsuen, Qionglin Shiang, Hsinchu County 307, Taiwan, R.O.C.

TEL:+886-3-592-8858 / FAX:+886-3-592-8859 E-Mail : service@quietek.com

LinKou Testing Laboratory :

No. 5-22, Rueishu Keng, Linkou Dist., New Taipei City 24451, Taiwan. R.O.C.

TEL : 886-2-8601-3788 / FAX : 886-2-8601-3789 E-Mail : service@quietek.com

Suzhou (China) Testing Laboratory :

No. 99 Hongye Rd., Suzhou Industrial Park Loufeng Hi-Tech Development Zone., Suzhou,China.

TEL : +86-512-6251-5088 / FAX : +86-512-6251-5098 E-Mail : service@quietek.com

TABLE OF CONTENTS

Description	Page
1. General Information	6
1.1. EUT Description.....	7
1.2. Mode of Operation	8
1.3. Tested System Details	9
1.4. EUT Test Setup Environment & Configuration of AIS System.....	10
1.5. Performance Check Method	11
1.6. EUT Operation Procedures.....	11
2. Technical Test	12
2.1. Summary of Test Result.....	12
2.2. List of Test Equipment.....	13
2.3. Measurement Uncertainty	14
2.4. Test Environment	15
3. Conducted Emission	16
3.1. Test Specification	16
3.2. Test Setup.....	16
3.3. Limit	16
3.4. Test Procedure.....	17
3.5. Deviation from Test Standard.....	17
3.6. Test Result	18
3.7. Test Photograph.....	30
4. Radiated Emission.....	32
4.1. Test Specification	32
4.2. Test Setup.....	32
4.3. Limit	32
4.4. Test Procedure.....	33
4.5. Deviation from Test Standard.....	33
4.6. Test Result	34
4.7. Test Photograph.....	66
5. Conducted Radio Frequency Disturbance	71
5.1. Test Specification	71
5.2. Test Setup.....	71
5.3. Limit	72
5.4. Test Procedure.....	72
5.5. Deviation from Test Standard.....	72
5.6. Test Result	73
5.7. Test Photograph.....	81
6. Radiated Radio Frequencies	83
6.1. Test Specification	83
6.2. Test Setup.....	83
6.3. Limit	83

6.4. Test Procedure.....	84
6.5. Deviation from Test Standard.....	84
6.6. Test Result	85
6.7. Test Photograph.....	89
7. Electrical Fast Transient/Burst	90
7.1. Test Specification	90
7.2. Test Setup.....	90
7.3. Limit	90
7.4. Test Procedure.....	91
7.5. Deviation from Test Standard.....	91
7.6. Test Result	92
7.7. Test Photograph.....	96
8. Power Supply Failure.....	97
8.1. Test Specification	97
8.2. Test Setup.....	97
8.3. Limit	97
8.4. Test Procedure.....	98
8.5. Deviation from Test Standard.....	98
8.6. Test Result	99
8.7. Test Photograph.....	103
9. Electrostatic Discharge	104
9.1. Test Specification	104
9.2. Test Setup.....	104
9.3. Limit	104
9.4. Test Procedure.....	105
9.5. Deviation from Test Standard.....	105
9.6. Test Result	106
9.7. Test Photograph.....	110
10. Electromagnetic Radio Frequency Radiation.....	111
10.1. Test Equipment	111
10.2. Method of test	111
10.3. Test Result and photos.....	111
11. Attachment.....	112
EUT Photograph	112

Revision History

Rev.	Issue Date	Revisions	Effect page
V1.0	July 23, 2013	Initial Issue	All
V2.0	October 21, 2013	<ol style="list-style-type: none"> 1. Add Revision History 2. Modify section 1.3 Tested System Details 3. Modify section 1.4 EUT Test Setup Environment & Configuration of AIS System 4. Add section 1.5 Performance Check Method 5. Modify section 1.6 EUT Operation Procedures 6. Correct the typing error of L.I.S.N. specification at section 3.4 7. Add separate diagrams for the frequency range from 156~165 MHz with appropriate quasi-peak measurements at section 4.6 8. Add information at section 5.6, 6.6, 7.6, 8.6 and 9.6 9. Correct the typing error of burst noise period at section 7.4 	6, 9, 10, 11, 17, 42, 43, 44, 45, 54, 55, 56, 57, 76, 80, 86, 88, 91, 93, 95, 100, 102, 107, 109

1. General Information

1.1. EUT Description

Product Name	AIS Class B Transponder
Trade Name	AMEC
Model No.	CAMINO-108, CAMINO-108W

Component	
Hardware	M-PCB-B108MBV1
Software	V1.2.6

Note:

- 1.The EUT is including two models.
- 2.The difference of each model is shown as below:

Model Number	Description
CAMINO-108	AIS Class B Transponder
CAMINO-108W	AIS Class B Transponder with Wi-Fi

1.2. Mode of Operation

QuieTek has verified the construction and function in typical operation. All the test modes were carried out with the EUT in normal operation, which was shown in this test report and defined as:

Test Mode	
Emission	Mode 1: DC 12V Mode 2: DC 24V
Immunity	Mode 1: DC 12V Mode 2: DC 24V

1.3. Tested System Details

The types for all equipment, plus descriptions of all cables used in the tested system (including SD card) are:

Product	Manufacturer	Model No.	Serial No.	Power Cord	
1	Notebook PC	DELL	PP04X	7607342512	Non-shielded, 1.8m
2	GPS Simulator	Agilent	E4438C	N/A	Non-shielded, 1.8m
3	AIS Transponders	AMEC	CAMINO-101 / CAMINO-701	N/A	Non-shielded, 1.8m

1.4. EUT Test Setup Environment & Configuration of AIS System

In order to do performance-check during EMC immunity tests, an equipment setup (AIS related) as shown in the following diagram is used in general.

A Satellite Simulator is used during the tests to emulate GPS signal source for the EUT.

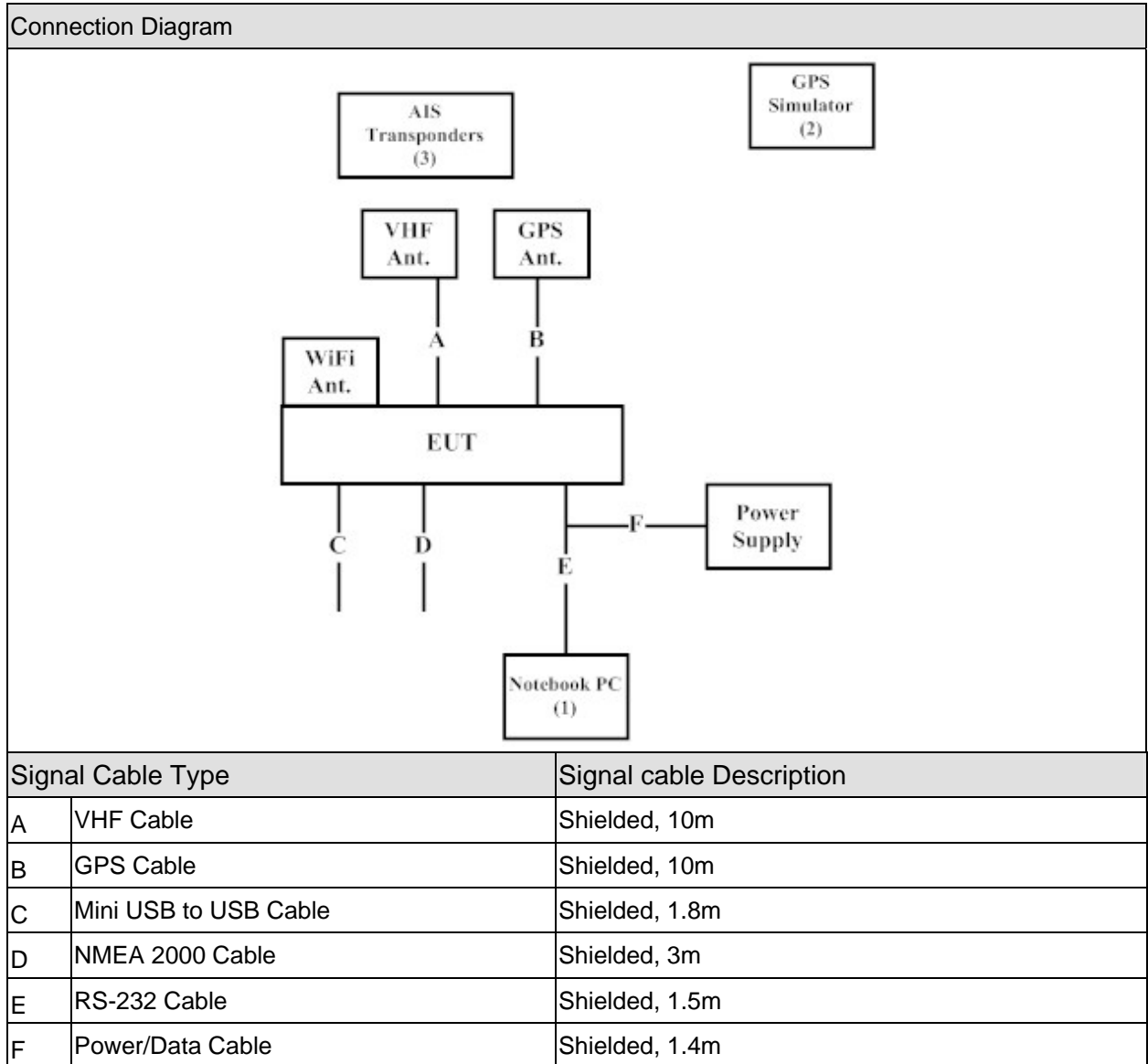

The Satellite Simulator (Agilent E4438C) is put outside the EMC chamber with cable connecting to GPS transmitting antenna inside the EMC chamber. The simulated-GPS-source-signal is transmitted from Satellite Simulator to EUT's GPS antenna (AMEC ANT-21) wirelessly.

1.5. Performance Check Method

The EUT is set into autonomous mode with reporting interval of 180 seconds in the test environment in Section 1.4. Additional AIS transponders are used to monitor the content of reports and the reporting intervals of EUT. The EUT performance shall not be degraded during or after the test. A PC software tool is used in parallel to record the AIS transmitting rate and receiving rate. The data is used to check if there is any degradation of performance or loss of function.

An IEC-61162 Datalogger software is used (running on PC) to check the EUT performance during and after the test together with the additional AIS transponders. The method and screenshots on how to verify the transmitting and receiving performance at the EUT are shown at Section 5.6, 6.6, 7.6, 8.6 and 9.6.

1.6. EUT Operation Procedures

1	Setup the EUT and simulators as shown in section 1.4.
2	Turn on the power of all equipment.
3	All the features of the EUT operation normally.

2. Technical Test

2.1. Summary of Test Result

- No deviations from the test standards
 Deviations from the test standards as below description:

Emission			
Performed Item	Normative References	Test Performed	Deviation
Conducted Emission	IEC 60945: 2002-08 chapter 9.2	Yes	No
Radiated Emission	IEC 60945: 2002-08 chapter 9.3	Yes	No

Immunity			
Performed Item	Normative References	Test Performed	Deviation
Conducted radio frequency disturbance	IEC 60945: 2002-08 chapter 10.3	Yes	No
Radiated radio frequencies	IEC 60945: 2002-08 chapter 10.4	Yes	No
Electrical Fast transient/burst	IEC 60945: 2002-08 chapter 10.5	Yes	No
Slow transient/surge	IEC 60945: 2002-08 chapter 10.6	No	No
Power Supply Variation Tests	IEC 60945: 2002-08 chapter 10.7	No	No
Power supply failure	IEC 60945: 2002-08 chapter 10.8	Yes	No
Electrostatic discharge	IEC 60945: 2002-08 chapter 10.9	Yes	No

2.2. List of Test Equipment

Conducted Emission / SR1

Instrument	Manufacturer	Type No.	Serial No	Cal. Date
EMI Test Receiver	R&S	ESCS 30	838251/001	2013/06/20
LISN	R&S	ENV216	100085	2013/01/30
LISN	R&S	ESH3-Z5	836679/023	2013/01/30
Pulse Limiter	R&S	ESH3-Z2	357.8810.52-1	2013/09/20
Coaxial Cable	QTK(Arnist)	RG 400	LC016-RG	2013/06/26

Radiated Emission / Site7

Instrument	Manufacturer	Type No.	Serial No	Cal. Date
Bilog Antenna	Schaffner Chase	CBL6112B	2930	2013/05/06
EMI Test Receiver	R&S	ESCI	100649	2013/04/18
Coaxial Cable	QTK(Arnist)	RG 214	LC007-RG	2013/06/23
Site7 NSA	QTK	N/A	N/A	2013/06/23
Pre-Amplifier	QTK	AP/0100A	CHM/1009094	2013/06/23

Radiated Emission / CB7

Instrument	Manufacturer	Type No.	Serial No	Cal. Date
EMI Test Receiver	R&S	ESU26	100433	2013/07/29
Horn Antenna	ETS-Lindgren	3117	00135205	2013/03/26
Horn Antenna	SCHWARZBECK	9120D	576	2012/11/19
Pre-Amplifier	Quietek	AP-180C	CHM/071920	2013/06/24
CB7 VSWR	QTK	N/A	N/A	2013/07/25

Conducted radio frequency disturbance / SR6

Instrument	Manufacturer	Type No.	Serial No	Cal. Date
Schaffner NSG 2070 RF-Generator	Schaffner	N/A	N/A	2013/05/16

Radiated susceptibility / CB5

Instrument	Manufacturer	Type No.	Serial No	Cal. Date
AF-BOX	R&S	AF-BOX ACCUST	100007	N/A
Audio Analyzer	R&S	UPL 16	100137	2013/05/09
Biconilog Antenna	EMCO	3149	00071675	N/A
Directional Coupler	A&R	DC 6180	22735	N/A
Power Amplifier	A&R	30S1G3	309453	N/A
Power Amplifier	A&R	100W10000M7	A285000010	N/A
Power Amplifier	SCHAFFNER	CBA9413B	4020	N/A
Power Amplifier	AR	75A250A	0325371	N/A
Power Meter	R&S	NRVD(P.M)	100219	2013/05/13
Pre-Amplifier	A&R	150A220	23067	N/A
Signal Generator	R&S	SMB100A	106404	2013/05/09
uniform field calibration	QTK	N/A	N/A	2013/05/20

Electrical fast transient/burst / SR3

Instrument	Manufacturer	Type No.	Serial No	Cal. Date
TRANSIENT TEST SYSTEM	EMC PARTNER	TRA2000IN6	1138	2013/03/22

Electrostatic Discharge / SR6

Instrument	Manufacturer	Type No.	Serial No	Cal. Date
ESD Simulator System	Noiseken	TC-815R	ESS0929097	2013/06/21
Horizontal Coupling Plane(HCP)	Quietek	HCP AL50	N/A	N/A
Vertical Coupling Plane(VCP)	Quietek	VCP AL50	N/A	N/A

2.3. Measurement Uncertainty

Conducted Emission

The measurement uncertainty is evaluated as ± 2.26 dB.

Radiated Emission

The measurement uncertainty is evaluated as ± 3.19 dB.

Conducted radio frequency disturbance

The immunity test signal from the CS system for unmodulated signal and monitoring for the test level with the uncertainty evaluation report for the injected modulated signal level through CDN and EM Clamp/Direct Injection as being 3.72 dB and 2.78 dB.

Radiated radio frequencies

The immunity test signal from the RS system for the uniform field strength and monitoring for the test level with the uncertainty evaluation report for the electrical field strength as being 2.72 dB.

Electrical Fast transient/burst

The immunity test signal from the EFT/Burst system with the calibrated uncertainty for the waveform of voltage, frequency and timing as being 1.63 % and 2.76%.

Power supply failure

The DC power supply system the calibrated uncertainty for the waveform of voltage and timing as being 1.63 % and 2.76%.

Electrostatic discharge

The immunity test signal from the ESD system the calibrated uncertainty for the waveform of voltage and timing as being 1.63 % and 2.76%.

2.4. Test Environment

Performed Item	Items	Required	Actual
Conducted Emission	Temperature (°C)	15-35	25
	Humidity (%RH)	25-75	48
	Barometric pressure (mbar)	860-1060	950-1000
Radiated Emission	Temperature (°C)	15-35	23
	Humidity (%RH)	25-75	45
	Barometric pressure (mbar)	860-1060	950-1000
Conducted radio frequency disturbance	Temperature (°C)	15-35	24
	Humidity (%RH)	25-75	50
	Barometric pressure (mbar)	860-1060	950-1000
Radiated radio frequencies	Temperature (°C)	15-35	23
	Humidity (%RH)	25-75	51
	Barometric pressure (mbar)	860-1060	950-1000
Electrical Fast transient/burst	Temperature (°C)	15-35	24
	Humidity (%RH)	25-75	58
	Barometric pressure (mbar)	860-1060	950-1000
Power supply failure	Temperature (°C)	15-35	22
	Humidity (%RH)	10-75	48
	Barometric pressure (mbar)	860-1060	950-1000
Electrostatic discharge	Temperature (°C)	15-35	20
	Humidity (%RH)	30-60	50
	Barometric pressure (mbar)	860-1060	950-1000

3. Conducted Emission

3.1. Test Specification

According to EMC Standard : IEC 60945

3.2. Test Setup

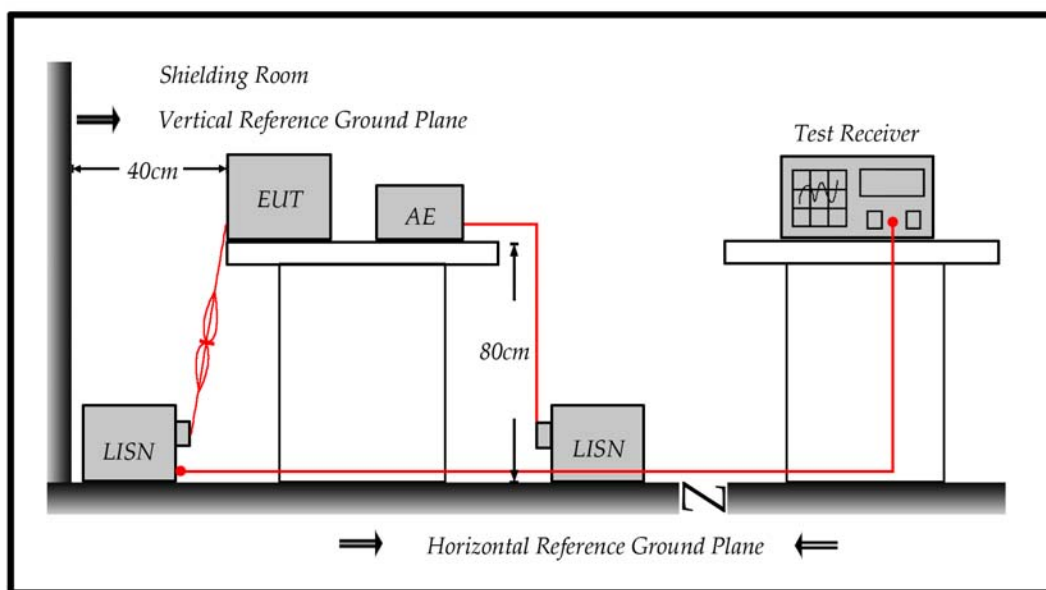

3.3. Limit

Limits		
Frequency (MHz)	QP (mV)	QP (dBuV)
0.01 – 0.15	63 – 0.3	96-50
0.15 – 0.35	1 – 0.3	60-50
0.35 – 30	0.3	50

Remarks: In the above table, the tighter limit applies at the band edges.

3.4. Test Procedure

The EUT and simulators are connected to the main power through a DC line impedance stabilization network (L.I.S.N.). This provides a 50 ohm /50uH coupling impedance for the measuring equipment. The peripheral devices are also connected to the main power through a LISN that provides a 50ohm/50uH coupling impedance with 50ohm termination.

(Please refers to the block diagram of the test setup and photographs.)

Both sides of D.C. line are checked for maximum conducted interference. In order to find the maximum emission, the relative positions of equipment and all of the interface cables must be changed on conducted measurement.

Conducted emissions were invested over the frequency range from 10kHz to 0.15MHz using a receiver bandwidth of 200Hz, 0.15MHz to 30MHz using a receiver bandwidth of 9kHz.

3.5. Deviation from Test Standard

No deviation.

3.6. Test Result

Site : SR1	Time : 2013/07/16 - 19:55
Limit : IEC60945_CLASSB_00M_QP	Margin : 10
EUT : AIS Class B Transponder	Probe : 8226_176(+)- Line1
Power : DC 12V	Note : Mode 1

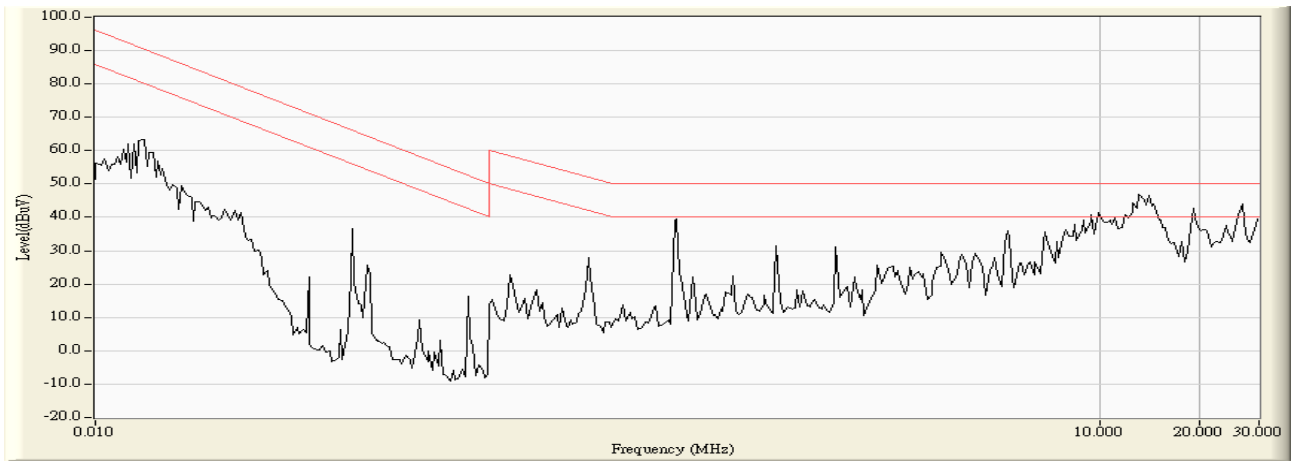

Site : SR1	Time : 2013/07/16 - 19:57
Limit : IEC60945_CLASSB_00M_QP	Margin : 0
EUT : AIS Class B Transponder	Probe : 8226_176(+)- Line1
Power : DC 12V	Note : Mode 1

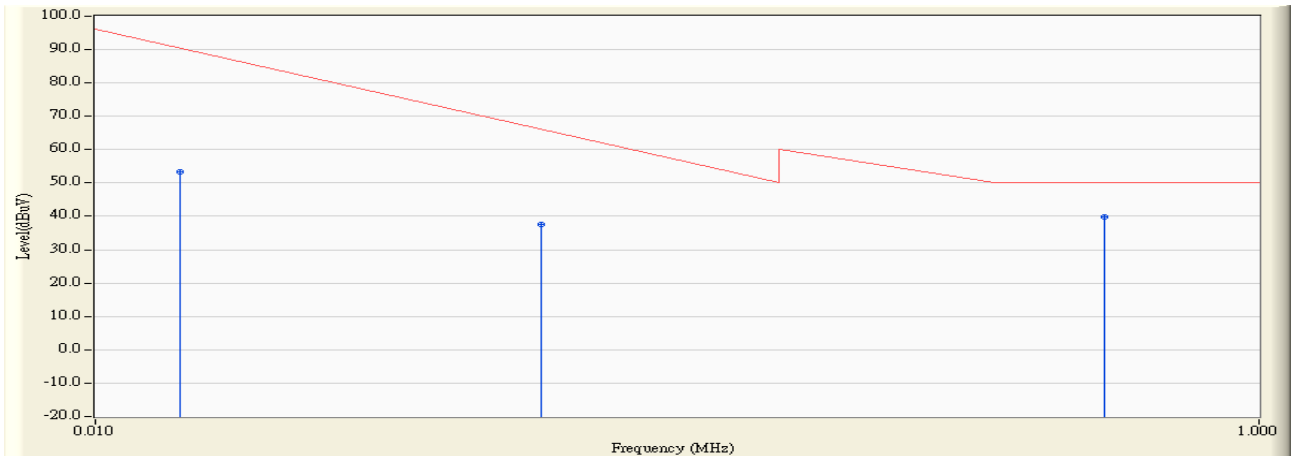

		Frequency (MHz)	Correct Factor (dB)	Reading Level (dBuV)	Measure Level (dBuV)	Margin (dB)	Limit (dBuV)	Detector Type
1		0.014	5.152	48.280	53.432	-41.252	94.684	QUASIPeAK
2		0.058	0.526	37.090	37.616	-42.468	80.084	QUASIPeAK
3	*	0.543	0.150	39.640	39.790	-10.210	50.000	QUASIPeAK

Note:

1. All Reading Levels are Quasi-Peak value.
2. " * ", means this data is the worst emission level.
3. Measurement Level = Reading Level + Correct Factor

Site : SR1	Time : 2013/07/16 - 19:57
Limit : IEC60945_CLASSB_00M_QP	Margin : 0
EUT : AIS Class B Transponder	Probe : 8226_176(+)- Line1
Power : DC 12V	Note : Mode 1

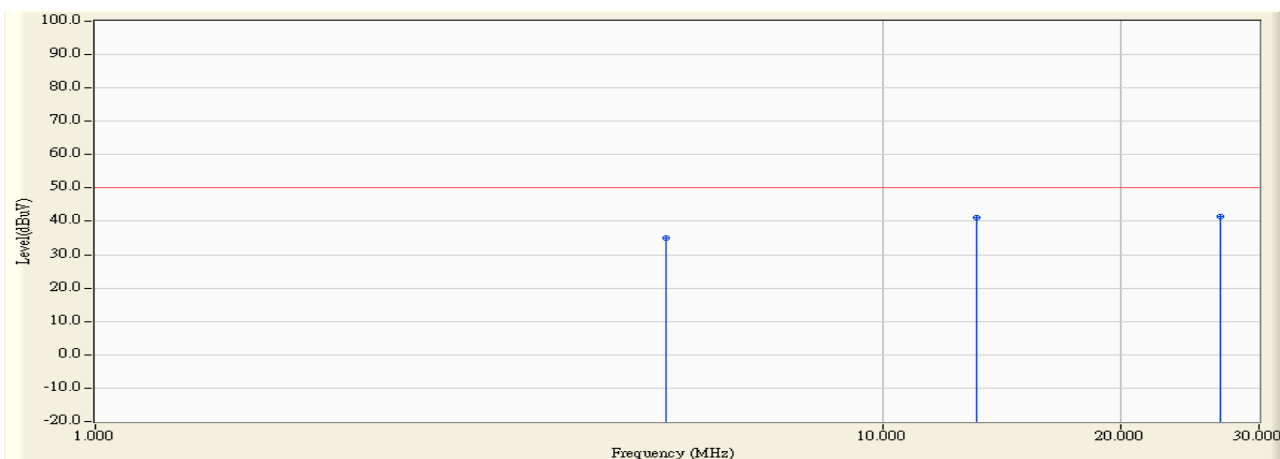

		Frequency (MHz)	Correct Factor (dB)	Reading Level (dBuV)	Measure Level (dBuV)	Margin (dB)	Limit (dBuV)	Detector Type
1		5.308	0.212	34.860	35.072	-14.928	50.000	QUASIPeAK
2		13.154	0.479	40.590	41.069	-8.931	50.000	QUASIPeAK
3	*	26.787	0.900	40.530	41.430	-8.570	50.000	QUASIPeAK

Note:

1. All Reading Levels are Quasi-Peak value.
2. " * ", means this data is the worst emission level.
3. Measurement Level = Reading Level + Correct Factor

Site : SR1	Time : 2013/07/16 - 20:00
Limit : IEC60945_CLASSB_00M_QP	Margin : 10
EUT : AIS Class B Transponder	Probe : 8226_177(-) - Line1
Power : DC 12V	Note : Mode 1

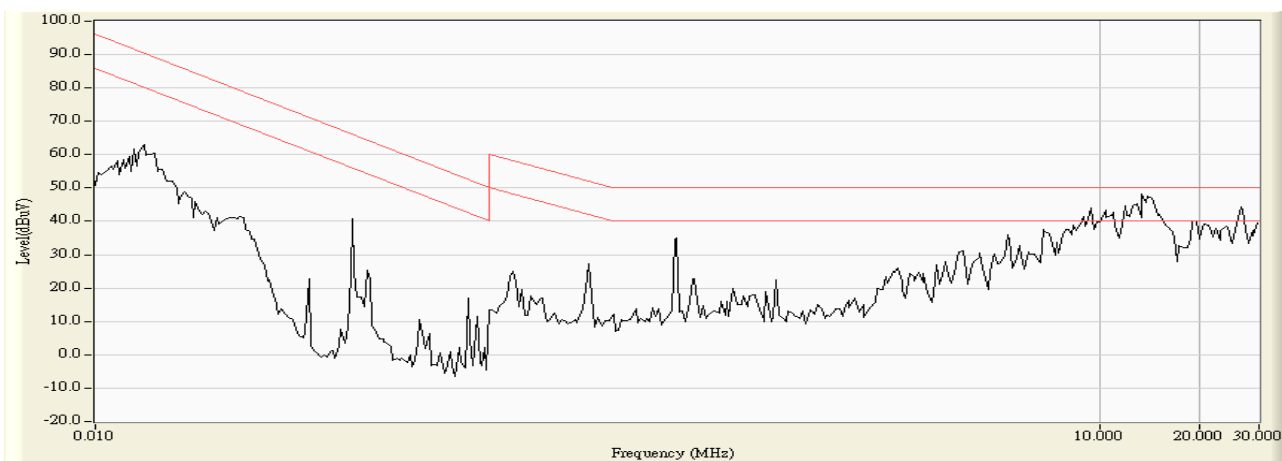

Site : SR1	Time : 2013/07/16 - 20:01
Limit : IEC60945_CLASSB_00M_QP	Margin : 0
EUT : AIS Class B Transponder	Probe : 8226_177(-) - Line1
Power : DC 12V	Note : Mode 1

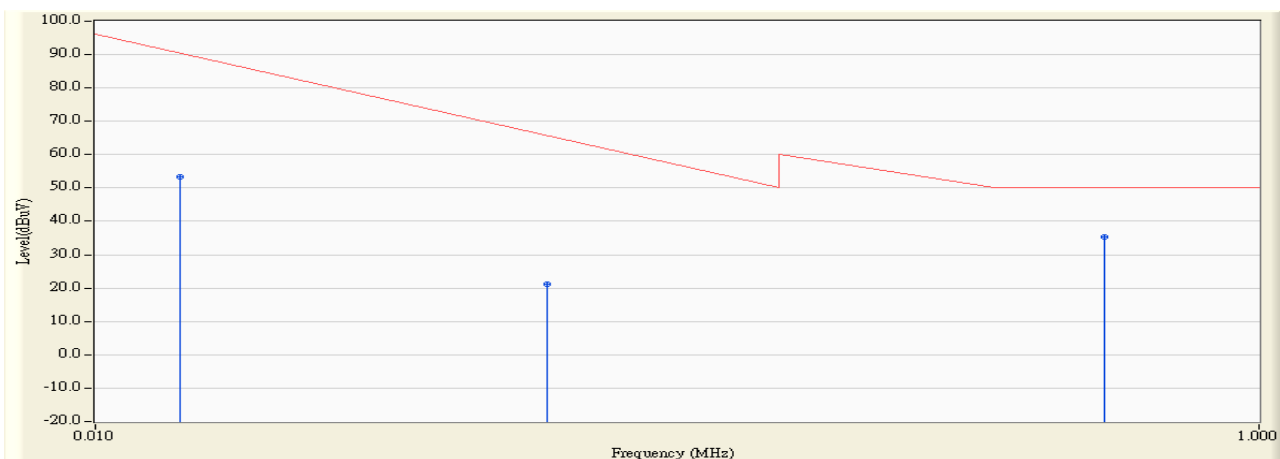

		Frequency (MHz)	Correct Factor (dB)	Reading Level (dBuV)	Measure Level (dBuV)	Margin (dB)	Limit (dBuV)	Detector Type
1		0.014	5.077	48.400	53.477	-41.207	94.684	QUASPEAK
2		0.060	0.510	20.710	21.220	-58.464	79.684	QUASPEAK
3	*	0.542	0.220	35.110	35.330	-14.670	50.000	QUASPEAK

Note:

1. All Reading Levels are Quasi-Peak value.
2. " * ", means this data is the worst emission level.
3. Measurement Level = Reading Level + Correct Factor

Site : SR1	Time : 2013/07/16 - 20:02
Limit : IEC60945_CLASSB_00M_QP	Margin : 0
EUT : AIS Class B Transponder	Probe : 8226_177(-) - Line1
Power : DC 12V	Note : Mode 1

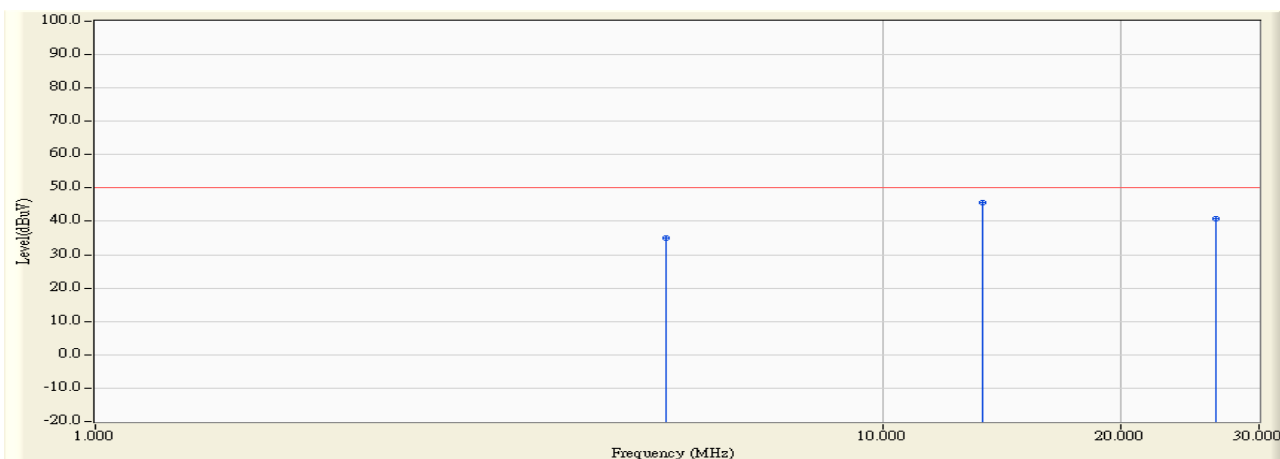

		Frequency (MHz)	Correct Factor (dB)	Reading Level (dBuV)	Measure Level (dBuV)	Margin (dB)	Limit (dBuV)	Detector Type
1		5.301	0.262	34.720	34.982	-15.018	50.000	QUASIPeAK
2	*	13.396	0.504	45.010	45.514	-4.486	50.000	QUASIPeAK
3		26.435	0.850	40.030	40.880	-9.120	50.000	QUASIPeAK

Note:

1. All Reading Levels are Quasi-Peak value.
2. " * ", means this data is the worst emission level.
3. Measurement Level = Reading Level + Correct Factor

Site : SR1	Time : 2013/07/16 - 20:08
Limit : IEC60945_CLASSB_00M_QP	Margin : 10
EUT : AIS Class B Transponder	Probe : 8226_176(+)- Line1
Power : DC 24V	Note : Mode 2

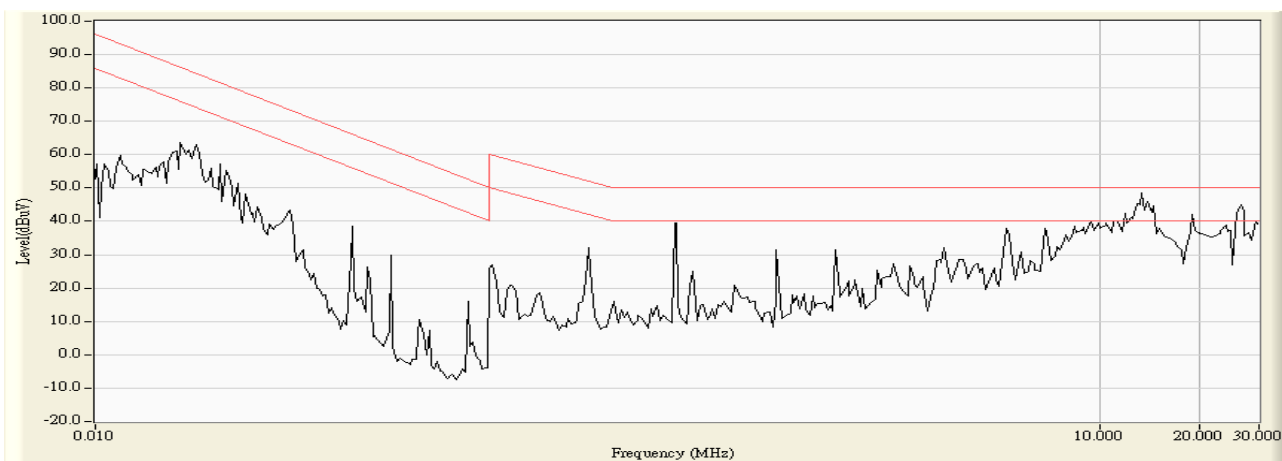

Site : SR1	Time : 2013/07/16 - 20:10
Limit : IEC60945_CLASSB_00M_QP	Margin : 0
EUT : AIS Class B Transponder	Probe : 8226_176(+)- Line1
Power : DC 24V	Note : Mode 2

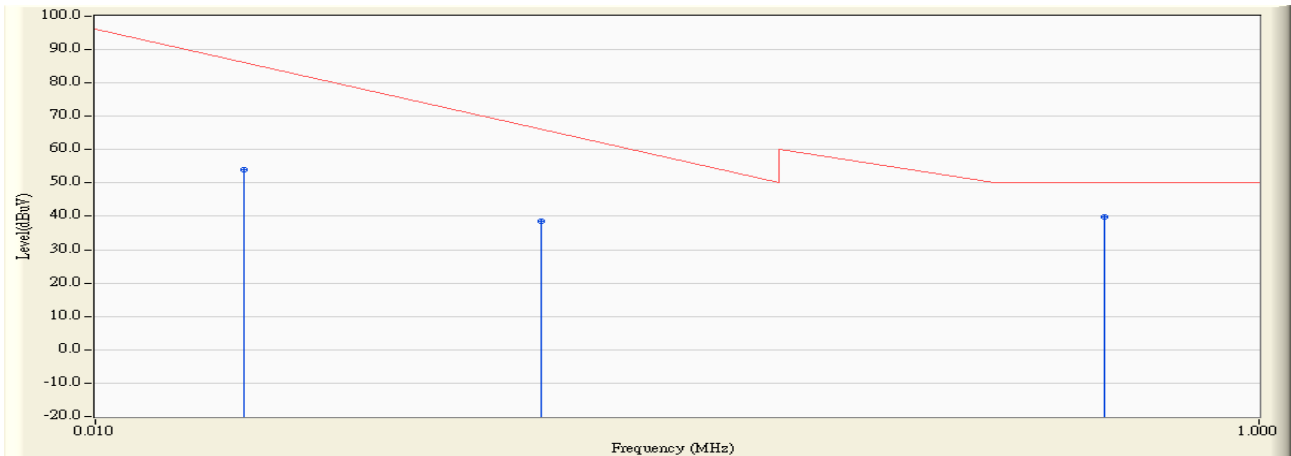

		Frequency (MHz)	Correct Factor (dB)	Reading Level (dBuV)	Measure Level (dBuV)	Margin (dB)	Limit (dBuV)	Detector Type
1		0.018	4.472	49.620	54.092	-39.288	93.381	QUASIPeAK
2		0.058	0.527	38.060	38.587	-41.517	80.105	QUASIPeAK
3	*	0.543	0.150	39.640	39.790	-10.210	50.000	QUASIPeAK

Note:

1. All Reading Levels are Quasi-Peak value.
2. " * ", means this data is the worst emission level.
3. Measurement Level = Reading Level + Correct Factor

Site : SR1	Time : 2013/07/16 - 20:10
Limit : IEC60945_CLASSB_00M_QP	Margin : 0
EUT : AIS Class B Transponder	Probe : 8226_176(+)- Line1
Power : DC 24V	Note : Mode 2

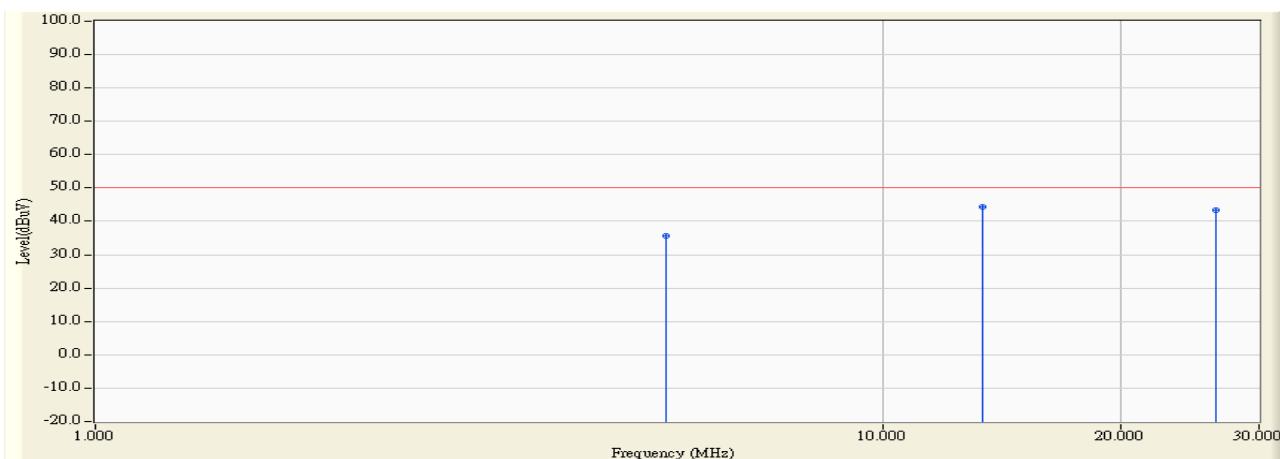

		Frequency (MHz)	Correct Factor (dB)	Reading Level (dBuV)	Measure Level (dBuV)	Margin (dB)	Limit (dBuV)	Detector Type
1		5.296	0.212	35.420	35.632	-14.368	50.000	QUASIPeAK
2	*	13.392	0.484	43.880	44.364	-5.636	50.000	QUASIPeAK
3		26.418	0.890	42.490	43.380	-6.620	50.000	QUASIPeAK

Note:

1. All Reading Levels are Quasi-Peak value.
2. " * ", means this data is the worst emission level.
3. Measurement Level = Reading Level + Correct Factor

Site : SR1	Time : 2013/07/16 - 20:14
Limit : IEC60945_CLASSB_00M_QP	Margin : 10
EUT : AIS Class B Transponder	Probe : 8226_177(-) - Line1
Power : DC 24V	Note : Mode 2

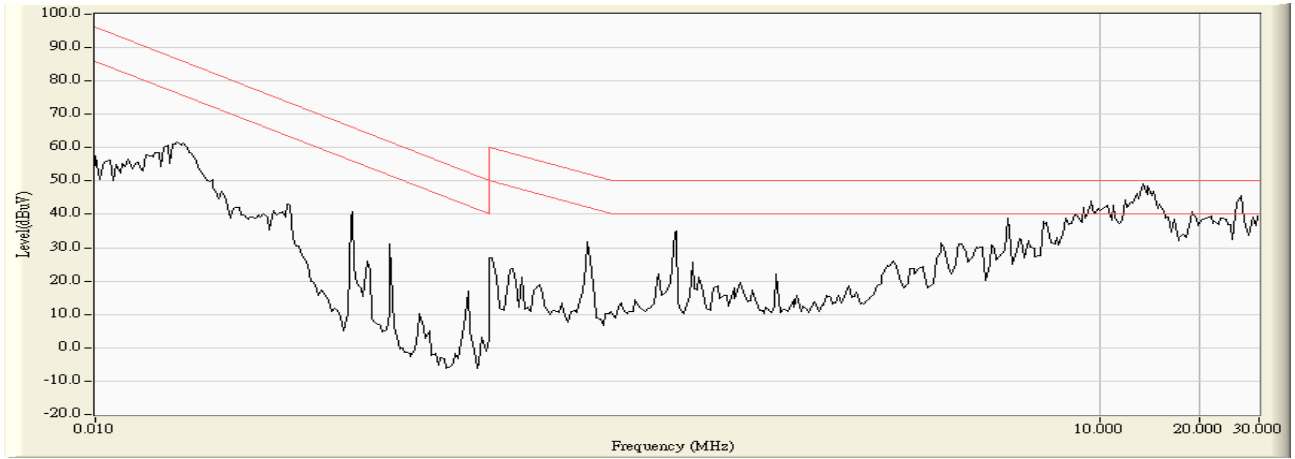

Site : SR1	Time : 2013/07/16 - 20:15
Limit : IEC60945_CLASSB_00M_QP	Margin : 0
EUT : AIS Class B Transponder	Probe : 8226_177(-) - Line1
Power : DC 24V	Note : Mode 2

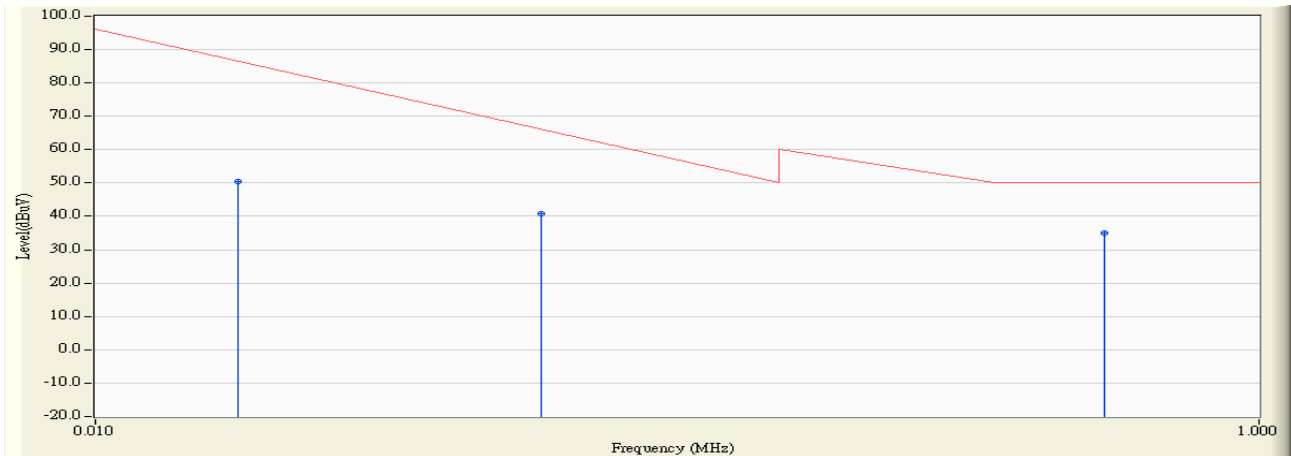

		Frequency (MHz)	Correct Factor (dB)	Reading Level (dBuV)	Measure Level (dBuV)	Margin (dB)	Limit (dBuV)	Detector Type
1		0.018	4.464	46.060	50.524	-42.977	93.501	QUASIPeAK
2		0.058	0.528	40.360	40.888	-39.196	80.084	QUASIPeAK
3	*	0.543	0.220	34.860	35.080	-14.920	50.000	QUASIPeAK

Note:

1. All Reading Levels are Quasi-Peak value.
2. " * ", means this data is the worst emission level.
3. Measurement Level = Reading Level + Correct Factor

Site : SR1	Time : 2013/07/16 - 20:16
Limit : IEC60945_CLASSB_00M_QP	Margin : 0
EUT : AIS Class B Transponder	Probe : 8226_177(-) - Line1
Power : DC 24V	Note : Mode 2

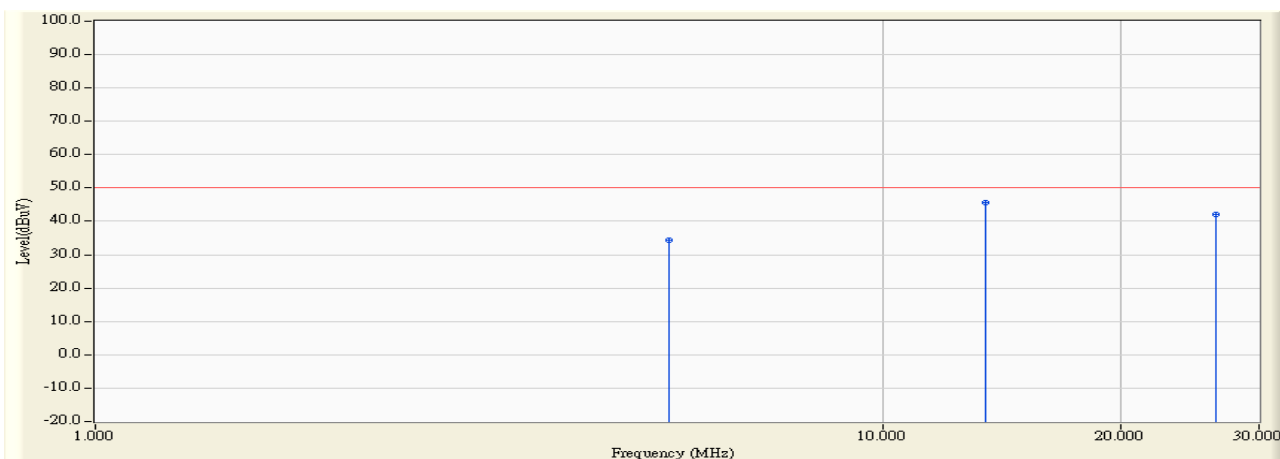

		Frequency (MHz)	Correct Factor (dB)	Reading Level (dBuV)	Measure Level (dBuV)	Margin (dB)	Limit (dBuV)	Detector Type
1		5.345	0.263	34.120	34.383	-15.617	50.000	QUASIPeAK
2	*	13.490	0.516	45.150	45.666	-4.334	50.000	QUASIPeAK
3		26.417	0.850	41.110	41.960	-8.040	50.000	QUASIPeAK

Note:

1. All Reading Levels are Quasi-Peak value.
2. " * ", means this data is the worst emission level.
3. Measurement Level = Reading Level + Correct Factor

3.7. Test Photograph

Test Mode : Mode 1: DC 12V

Description : Front View of Conducted Test



Test Mode : Mode 1: DC 12V

Description : Side View of Conducted Test



Test Mode : Mode 2: DC 24V

Description : Front View of Conducted Test



Test Mode : Mode 2: DC 24V

Description : Side View of Conducted Test



4. Radiated Emission

4.1. Test Specification

According to EMC Standard : IEC 60945

4.2. Test Setup

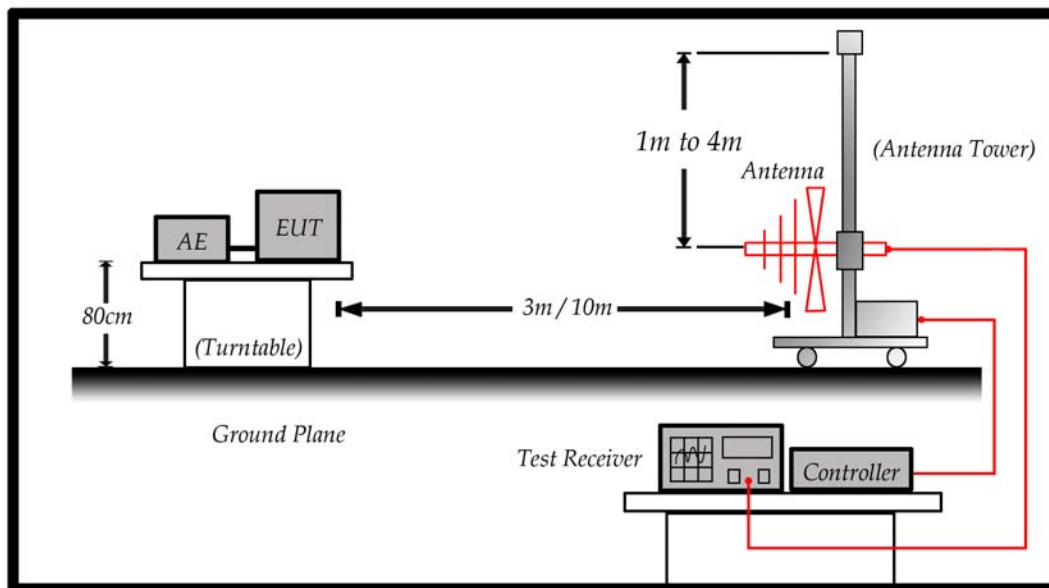

4.3. Limit

Limits		
Frequency (MHz)	Distance (m)	dBuV/m
0.15 – 0.3	3	80 – 52
0.3 – 30	3	52 – 34
30 – 2000	3	54
156 – 165	3	24

Remark:

1. The tighter limit shall apply at the edge between two frequency bands.
2. Distance refers to the distance in meters between the measuring instrument antenna and the closed point of any part of the device or system.

4.4. Test Procedure

The EUT and its simulators are placed on a turn table which is 0.8 meter above ground. The turn table can rotate 360 degrees to determine the position of the maximum emission level. The EUT was positioned such that the distance from antenna to the EUT was 3 meters. The antenna can move up and down between 1 meter and 4 meters to find out the maximum emission level.

Both horizontal and vertical polarization of the antenna are set on measurement. In order to find the maximum emission, all of the interface cables must be manipulated on radiated measurement.

Radiated emissions were investigated over the frequency range from 0.15MHz to 30MHz and 156MHz to 165MHz using a receiver bandwidth of 9kHz and 30MHz to 2GHz using a receiver bandwidth of 120kHz. Radiated was performed at an antenna to EUT distance of 3 meters.

4.5. Deviation from Test Standard

No deviation.

4.6. Test Result

Site: CB7	Time: 2013/07/18 - 03:01
Limit: IEC_60945_150K-30M_00M_QP	Margin: 6
Probe: HLA6120_1109	Polarity: Horizontal
EUT : AIS Class B Transponder	Power: DC 12V
Note : Mode 1	



Site: CB7	Time: 2013/07/18 - 03:10
Limit: IEC_60945_150K-30M_00M_QP	Margin: 6
Probe: HLA6120_1109	Polarity: Vertical
EUT : AIS Class B Transponder	Power: DC 12V
Note : Mode 1	



Site: CB7	Time: 2013/07/18 - 03:06
Limit: IEC_60945_150K-30M_00M_QP	Margin: 6
Probe: HLA6120_1109	Polarity: Horizontal
EUT: AIS Class B Transponder	Power: DC 12V
Note : Mode 1	

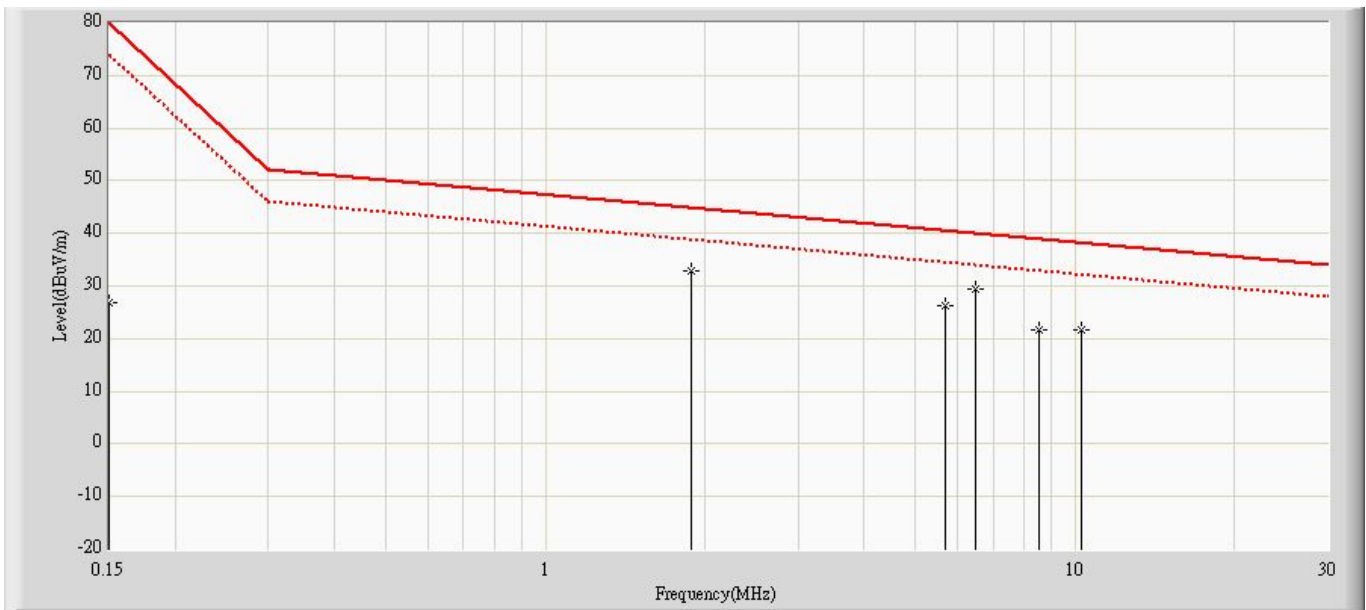

No	Flag	Mark	Frequency (MHz)	Measure Level (dBuV/m)	Reading Level (dBuV)	Over Limit (dB)	Limit (dBuV/m)	Factor	Type
1			0.150	26.900	30.680	-53.100	80.000	-3.780	QP
2			1.881	32.888	36.850	-11.937	44.825	-3.962	QP
3			5.702	26.131	29.860	-14.359	40.490	-3.729	QP
4		*	6.478	29.370	32.960	-10.621	39.991	-3.590	QP
5			8.524	21.669	25.060	-17.249	38.918	-3.391	QP
6			10.246	21.604	24.860	-16.595	38.199	-3.256	QP

Note:

1. All Readings below 1GHz are Quasi-Peak, above are performed with peak and/or average measurements as necessary.
2. " * ", means this data is the worst emission level.
3. Measurement Level = Reading Level + Factor(Probe+Cable-Amp).

Site: CB7	Time: 2013/07/18 - 03:15
Limit: IEC_60945_150K-30M_00M_QP	Margin: 6
Probe: HLA6120_1109	Polarity: Vertical
EUT: AIS Class B Transponder	Power: DC 12V
Note : Mode 1	

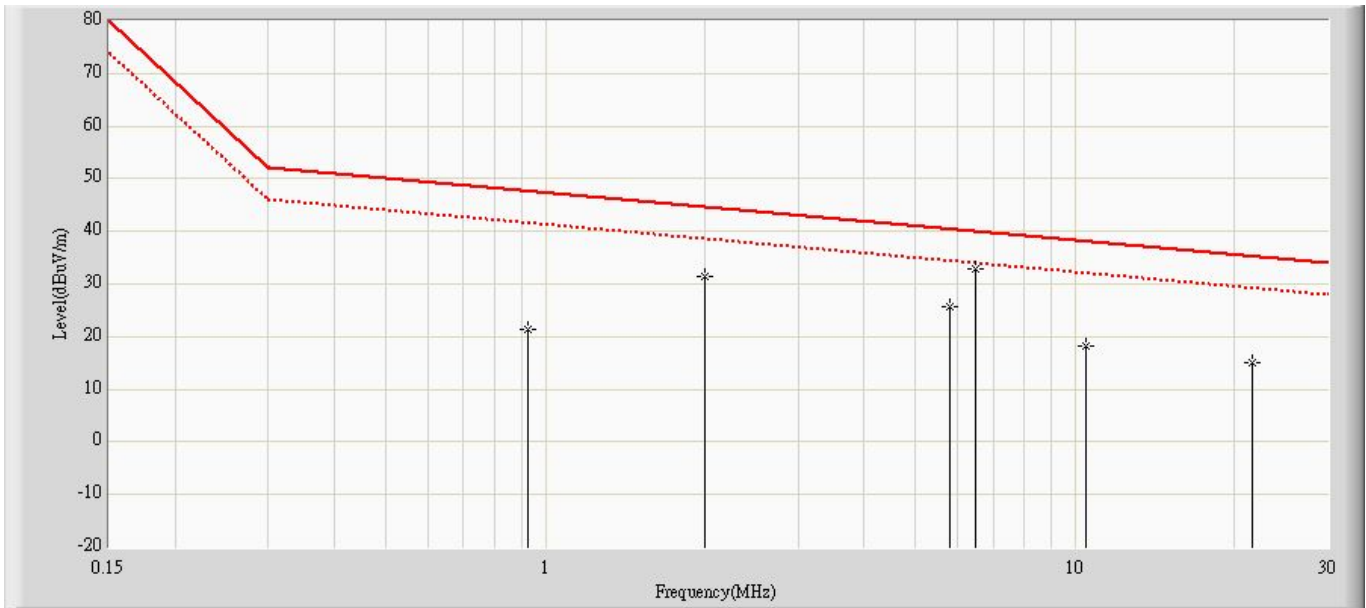

No	Flag	Mark	Frequency (MHz)	Measure Level (dBuV/m)	Reading Level (dBuV)	Over Limit (dB)	Limit (dBuV/m)	Factor	Type
1			0.929	21.329	25.370	-26.253	47.582	-4.041	QP
2			2.000	31.565	35.530	-13.020	44.585	-3.965	QP
3			5.808	25.642	29.350	-14.776	40.418	-3.708	QP
4		*	6.478	32.950	36.540	-7.041	39.991	-3.590	QP
5			10.496	18.270	21.510	-19.835	38.105	-3.240	QP
6			21.594	15.103	18.150	-20.183	35.285	-3.047	QP

Note:

1. All Readings below 1GHz are Quasi-Peak, above are performed with peak and/or average measurements as necessary.
2. " * ", means this data is the worst emission level.
3. Measurement Level = Reading Level + Factor(Probe+Cable-Amp).

Site : CB7	Time : 2013/07/19 - 06:31
Limit : IEC_60945_30M-2G_00M_QP	Margin : 6
EUT : AIS Class B Transponder	Probe : CB7_CBL6112_1307 - HORIZONTAL
Power : DC 12V	Note : Mode 1

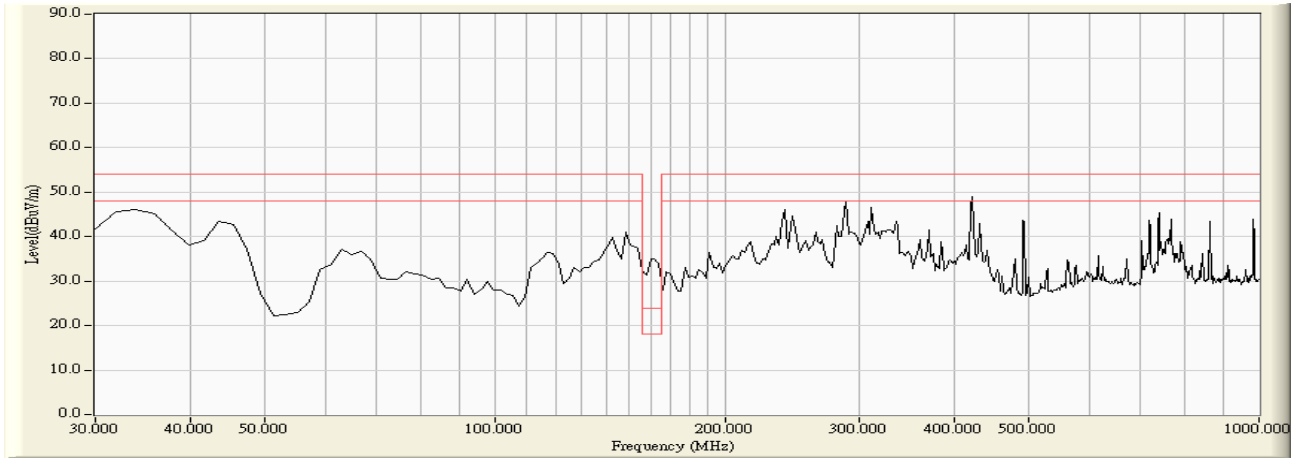

Site : CB7	Time : 2013/07/19 - 06:33
Limit : IEC_60945_30M-2G_00M_QP	Margin : 6
EUT : AIS Class B Transponder	Probe : CB7_CBL6112_1307 - VERTICAL
Power : DC 12V	Note : Mode 1

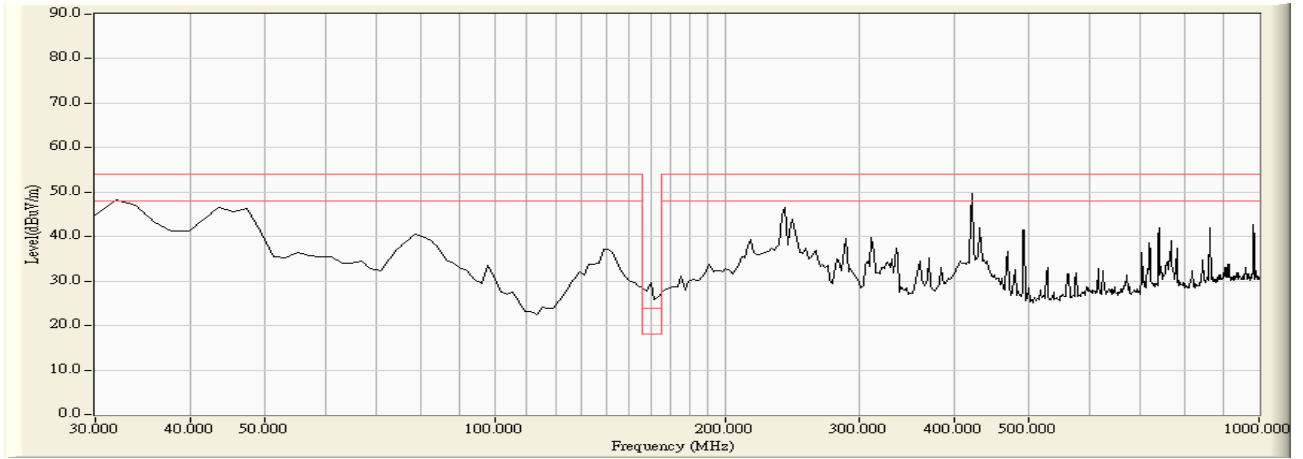

Site : Site7	Time : 2013/07/18 - 11:04
Limit : IEC60945_3M_QP	Margin : 6
EUT : AIS Class B Transponder	Probe : Site7_CBL6112_3M_1307 - HORIZONTAL
Power : DC 12V	Note : Mode 1

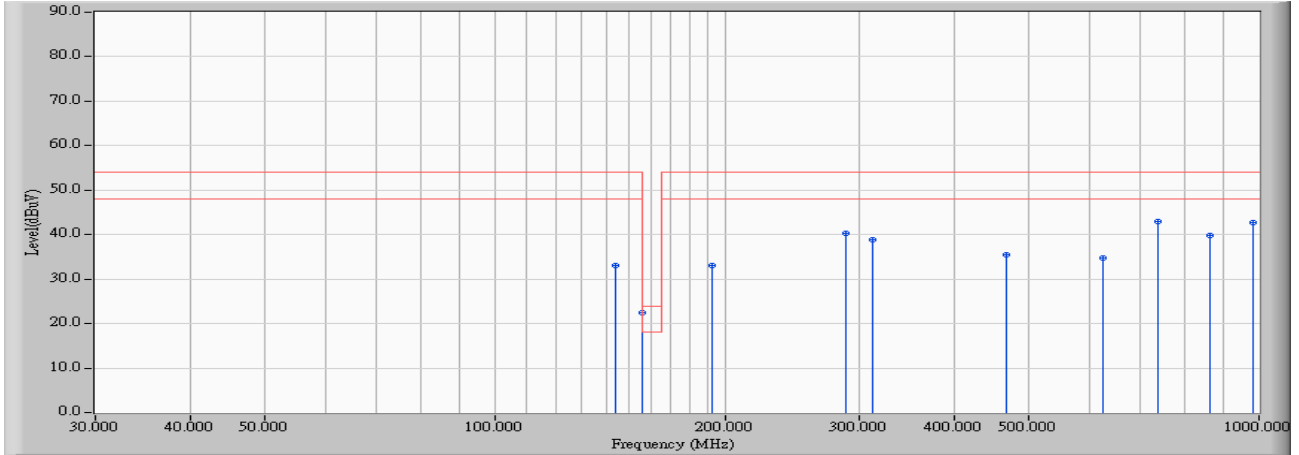

	Frequency (MHz)	Correct Factor (dB)	Reading Level (dBuV)	Measure Level (dBuV)	Margin (dB)	Limit (dBuV)	Detector Type
1	144.010	-18.317	51.330	33.013	-20.987	54.000	QUASIPeAK
2	* 156.000	-18.679	41.000	22.321	-1.679	24.000	QUASIPeAK
3	192.000	-19.259	52.300	33.041	-20.959	54.000	QUASIPeAK
4	288.000	-14.260	54.500	40.239	-13.761	54.000	QUASIPeAK
5	312.000	-13.339	52.300	38.962	-15.038	54.000	QUASIPeAK
6	468.000	-8.399	43.900	35.502	-18.498	54.000	QUASIPeAK
7	624.000	-5.362	40.140	34.777	-19.223	54.000	QUASIPeAK
8	739.000	-3.822	46.700	42.879	-11.121	54.000	QUASIPeAK
9	862.000	-1.660	41.400	39.740	-14.260	54.000	QUASIPeAK
10	982.000	-0.062	42.780	42.719	-11.281	54.000	QUASIPeAK

Note:

1. All Reading Levels are Quasi-Peak and average value.
2. " * ", means this data is the worst emission level.
3. Measurement Level = Reading Level + Correct Factor

Site : Site7	Time : 2013/07/18 - 11:05
Limit : IEC60945_3M_QP	Margin : 6
EUT : AIS Class B Transponder	Probe : Site7_CBL6112_3M_1307 - VERTICAL
Power : DC 12V	Note : Mode 1

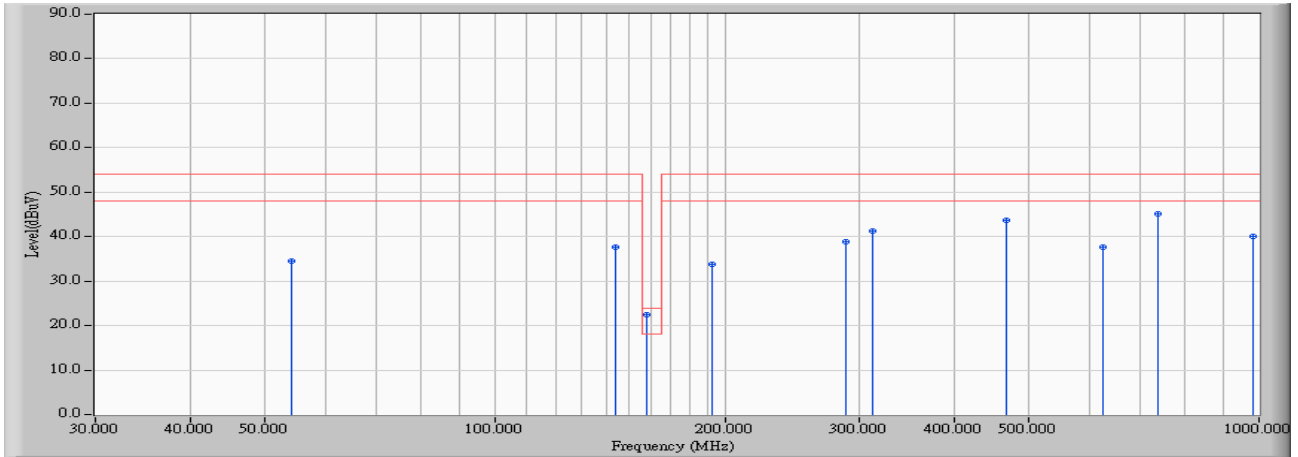

	Frequency (MHz)	Correct Factor (dB)	Reading Level (dBuV)	Measure Level (dBuV)	Margin (dB)	Limit (dBuV)	Detector Type
1	54.300	-22.522	57.000	34.478	-19.522	54.000	QUASIPeAK
2	144.000	-18.316	56.000	37.684	-16.316	54.000	QUASIPeAK
3	* 158.000	-18.689	41.100	22.410	-1.590	24.000	QUASIPeAK
4	192.000	-19.259	53.000	33.741	-20.259	54.000	QUASIPeAK
5	288.000	-14.260	53.200	38.939	-15.061	54.000	QUASIPeAK
6	312.000	-13.339	54.500	41.162	-12.838	54.000	QUASIPeAK
7	468.000	-8.399	52.000	43.602	-10.398	54.000	QUASIPeAK
8	624.000	-5.362	43.000	37.637	-16.363	54.000	QUASIPeAK
9	739.000	-3.822	49.000	45.179	-8.821	54.000	QUASIPeAK
10	982.000	-0.062	40.000	39.939	-14.061	54.000	QUASIPeAK

Note:

1. All Reading Levels are Quasi-Peak and average value.
2. " * ", means this data is the worst emission level.
3. Measurement Level = Reading Level + Correct Factor

Site : CB7	Time : 2013/09/27 - 16:00
Limit : IEC_60945_30M-2G_00M_QP	Margin : 6
EUT : AIS Class B Transponder	Probe : CB7_CBL6112_1307 - HORIZONTAL
Power : DC 12V	Note : Mode 1

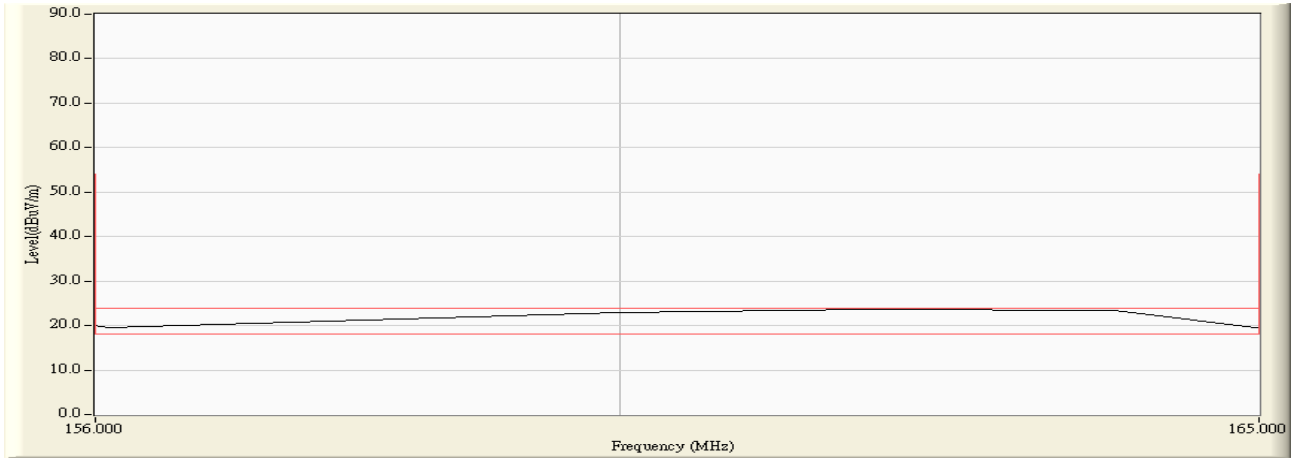

Site : CB7	Time : 2013/09/27 - 16:12
Limit : IEC_60945_30M-2G_00M_QP	Margin : 6
EUT : AIS Class B Transponder	Probe : CB7_CBL6112_1307 - VERTICAL
Power : DC 12V	Note : Mode 1

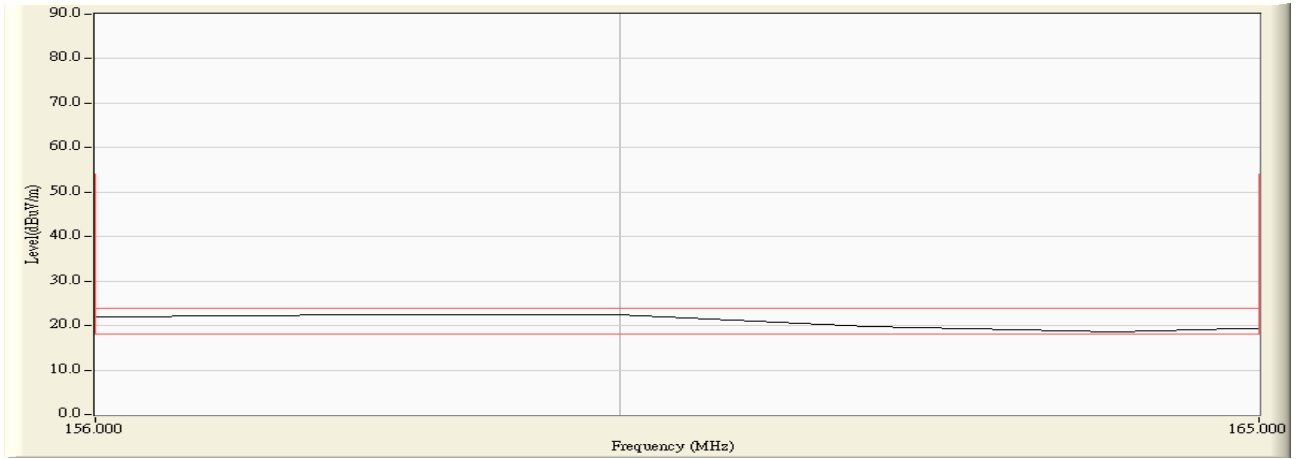

Site : Site7	Time : 2013/09/27 - 17:35
Limit : IEC60945_3M_QP	Margin : 6
EUT : AIS Class B Transponder	Probe : Site7_CBL6112_3M_1307 - HORIZONTAL
Power : DC 12V	Note : Mode 1

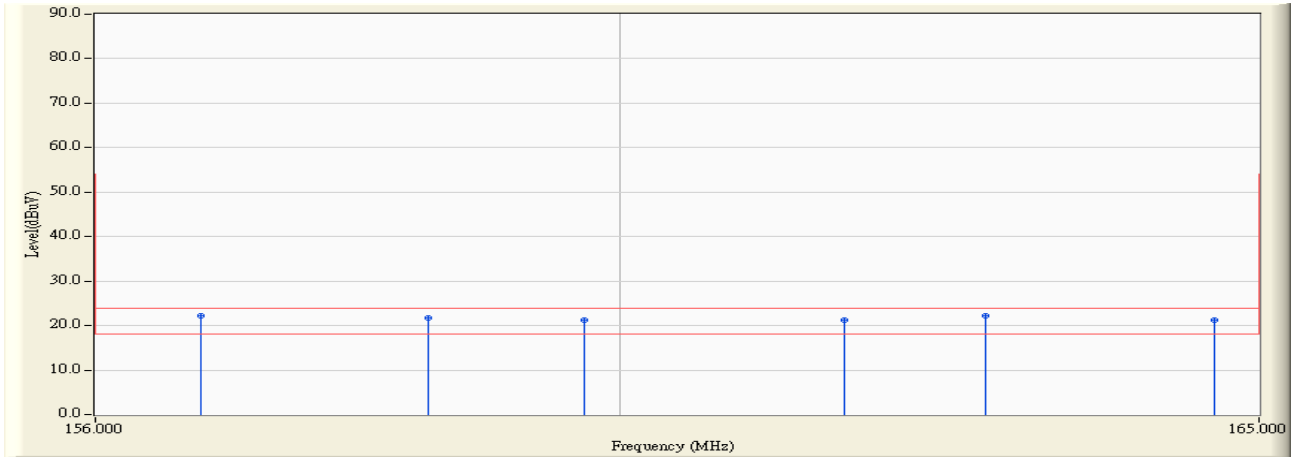

		Frequency (MHz)	Correct Factor (dB)	Reading Level (dBuV)	Measure Level (dBuV)	Margin (dB)	Limit (dBuV)	Detector Type
1		156.790	-18.680	40.800	22.120	-1.880	24.000	QUASIPeAK
2		158.520	-18.690	40.370	21.680	-2.320	24.000	QUASIPeAK
3		159.720	-18.698	40.000	21.303	-2.697	24.000	QUASIPeAK
4		161.740	-18.791	40.000	21.209	-2.791	24.000	QUASIPeAK
5	*	162.840	-18.838	41.000	22.162	-1.838	24.000	QUASIPeAK
6		164.640	-18.930	40.200	21.270	-2.730	24.000	QUASIPeAK

Note:

1. All Reading Levels are Quasi-Peak and average value.
2. " * ", means this data is the worst emission level.
3. Measurement Level = Reading Level + Correct Factor

Site : Site7	Time : 2013/09/27 - 17:29
Limit : IEC60945_3M_QP	Margin : 6
EUT : AIS Class B Transponder	Probe : Site7_CBL6112_3M_1307 - VERTICAL
Power : DC 12V	Note : Mode 1

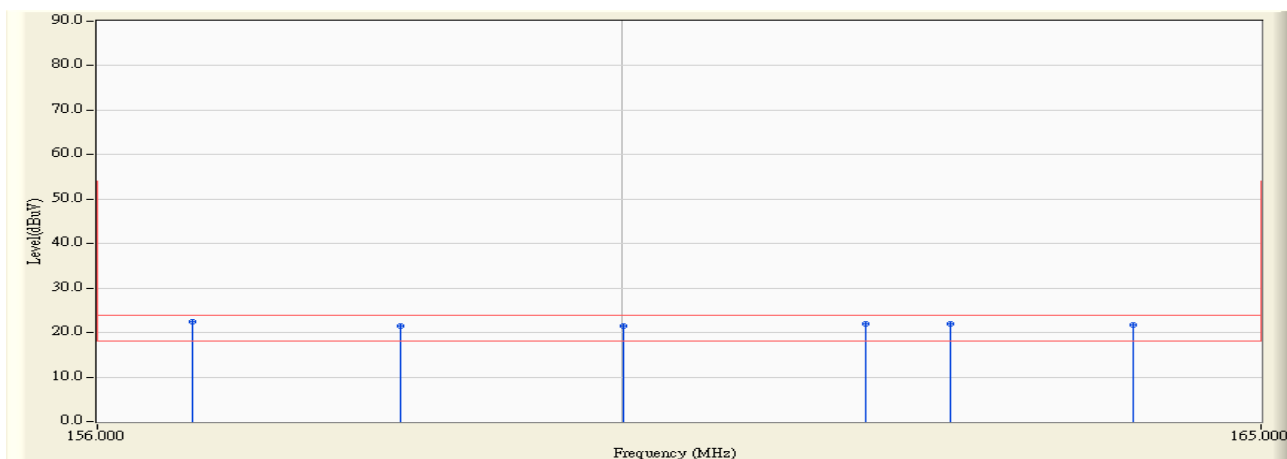

		Frequency (MHz)	Correct Factor (dB)	Reading Level (dBuV)	Measure Level (dBuV)	Margin (dB)	Limit (dBuV)	Detector Type
1	*	156.720	-18.680	41.100	22.420	-1.580	24.000	QUASIPeAK
2		158.300	-18.690	40.100	21.410	-2.590	24.000	QUASIPeAK
3		160.010	-18.702	40.240	21.538	-2.462	24.000	QUASIPeAK
4		161.880	-18.798	40.820	22.022	-1.978	24.000	QUASIPeAK
5		162.550	-18.826	40.800	21.974	-2.026	24.000	QUASIPeAK
6		163.990	-18.897	40.580	21.683	-2.317	24.000	QUASIPeAK

Note:

1. All Reading Levels are Quasi-Peak and average value.
2. " * ", means this data is the worst emission level.
3. Measurement Level = Reading Level + Correct Factor

Site: CB7	Time: 2013/07/18 - 03:35
Limit: IEC_60945_150K-30M_00M_QP	Margin: 6
Probe: HLA6120_1109	Polarity: Horizontal
EUT: AIS Class B Transponder	Power: DC 24V
Note : Mode 2	

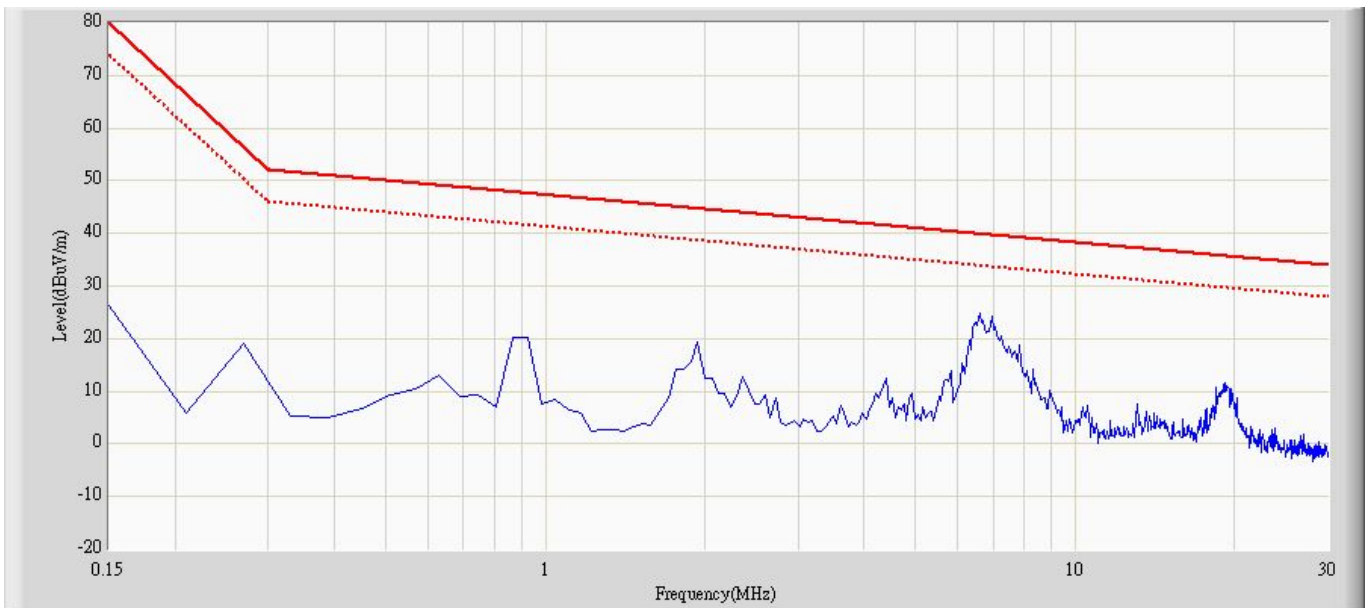

Site: CB7	Time: 2013/07/18 - 03:24
Limit: IEC_60945_150K-30M_00M_QP	Margin: 6
Probe: HLA6120_1109	Polarity: Vertical
EUT: AIS Class B Transponder	Power: DC 24V
Note : Mode 2	

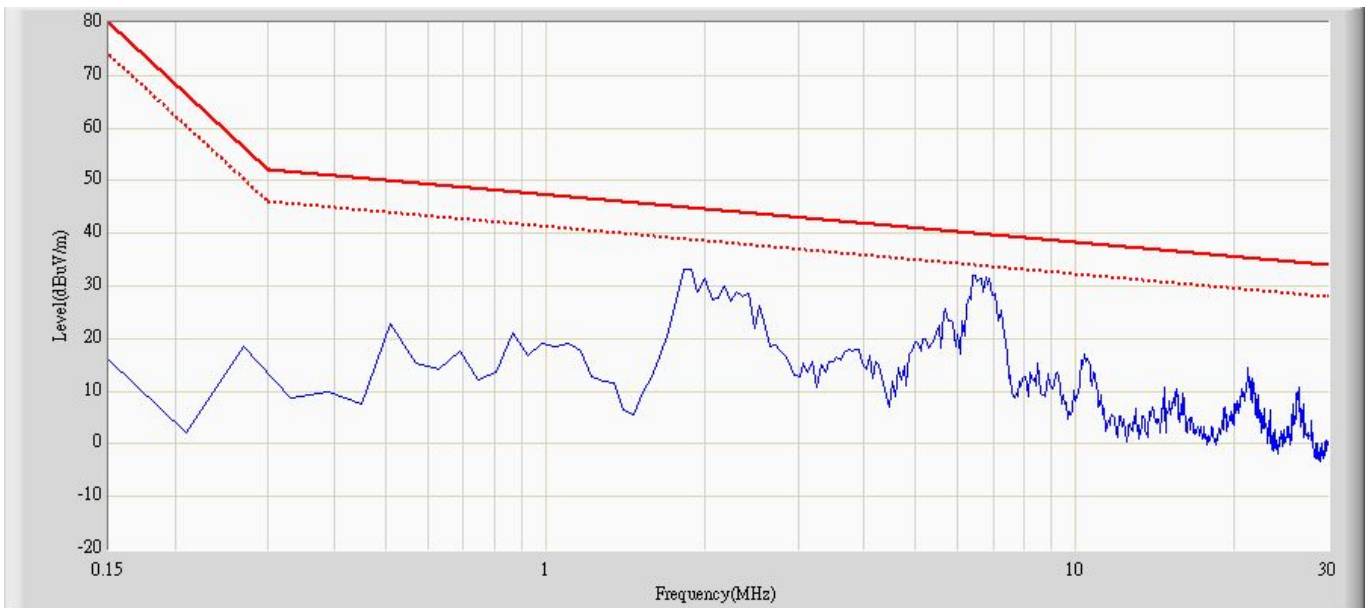

Site: CB7	Time: 2013/07/18 - 03:37
Limit: IEC_60945_150K-30M_00M_QP	Margin: 6
Probe: HLA6120_1109	Polarity: Horizontal
EUT: AIS Class B Transponder	Power: DC 24V
Note : Mode 2	

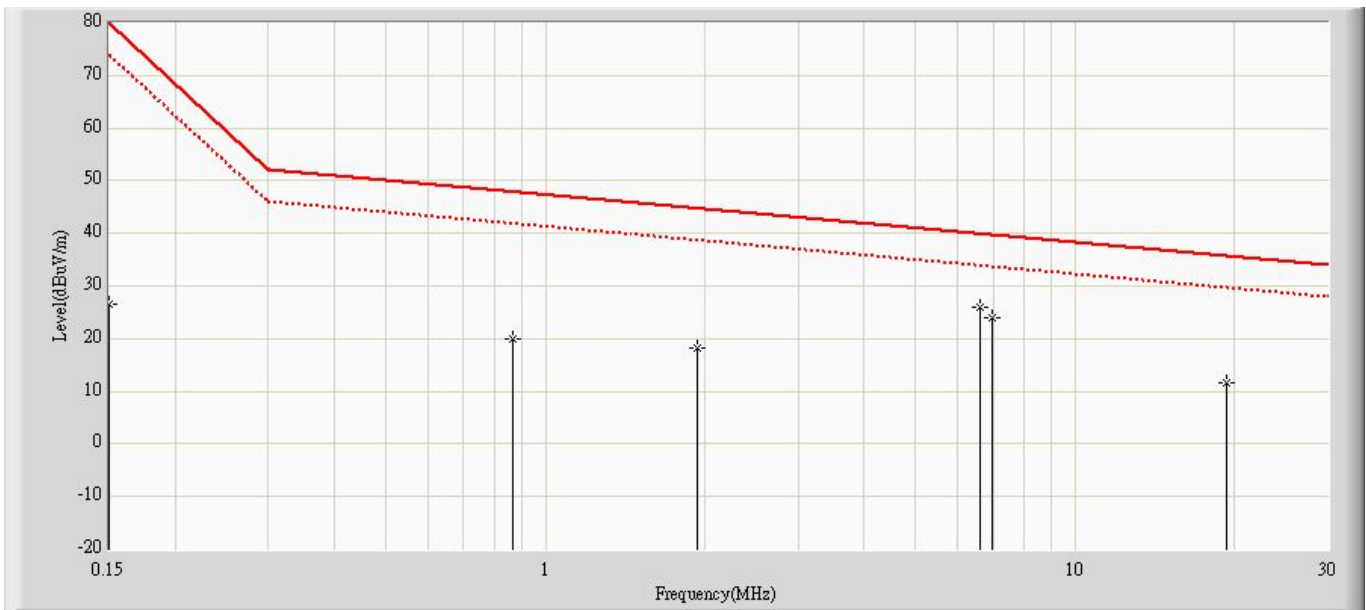

No	Flag	Mark	Frequency (MHz)	Measure Level (dBuV/m)	Reading Level (dBuV)	Over Limit (dB)	Limit (dBuV/m)	Factor	Type
1			0.150	26.490	30.270	-53.510	80.000	-3.780	QP
2			0.866	20.081	24.120	-27.775	47.856	-4.039	QP
3			1.941	18.206	22.170	-26.496	44.702	-3.964	QP
4		*	6.596	26.110	29.680	-13.810	39.921	-3.570	QP
5			6.980	24.104	27.610	-15.595	39.699	-3.506	QP
6			19.353	11.730	14.620	-23.983	35.713	-2.890	QP

Note:

1. All Readings below 1GHz are Quasi-Peak, above are performed with peak and/or average measurements as necessary.
2. " * ", means this data is the worst emission level.
3. Measurement Level = Reading Level + Factor(Probe+Cable-Amp).

Site: CB7	Time: 2013/07/18 - 03:33
Limit: IEC_60945_150K-30M_00M_QP	Margin: 6
Probe: HLA6120_1109	Polarity: Vertical
EUT: AIS Class B Transponder	Power: DC 24V
Note : Mode 2	

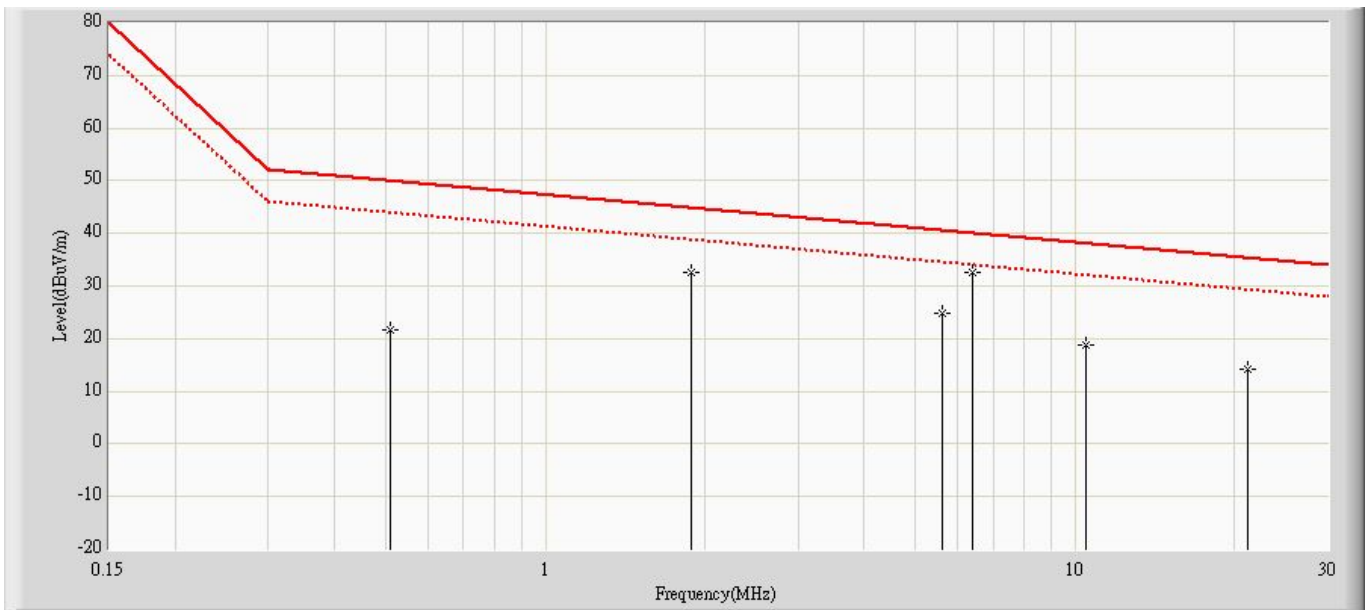

No	Flag	Mark	Frequency (MHz)	Measure Level (dBuV/m)	Reading Level (dBuV)	Over Limit (dB)	Limit (dBuV/m)	Factor	Type
1			0.508	21.627	25.560	-28.314	49.941	-3.933	QP
2			1.881	32.608	36.570	-12.217	44.825	-3.962	QP
3			5.626	24.808	28.550	-15.734	40.542	-3.741	QP
4		*	6.418	32.630	36.230	-7.397	40.027	-3.600	QP
5			10.456	18.728	21.970	-19.392	38.120	-3.242	QP
6			21.221	14.245	17.260	-21.108	35.353	-3.015	QP

Note:

1. All Readings below 1GHz are Quasi-Peak, above are performed with peak and/or average measurements as necessary.
2. " * ", means this data is the worst emission level.
3. Measurement Level = Reading Level + Factor(Probe+Cable-Amp).

Site : CB7	Time : 2013/07/19 - 06:39
Limit : IEC_60945_30M-2G_00M_QP	Margin : 6
EUT : AIS Class B Transponder	Probe : CB7_CBL6112_1307 - HORIZONTAL
Power : DC 24V	Note : Mode 2

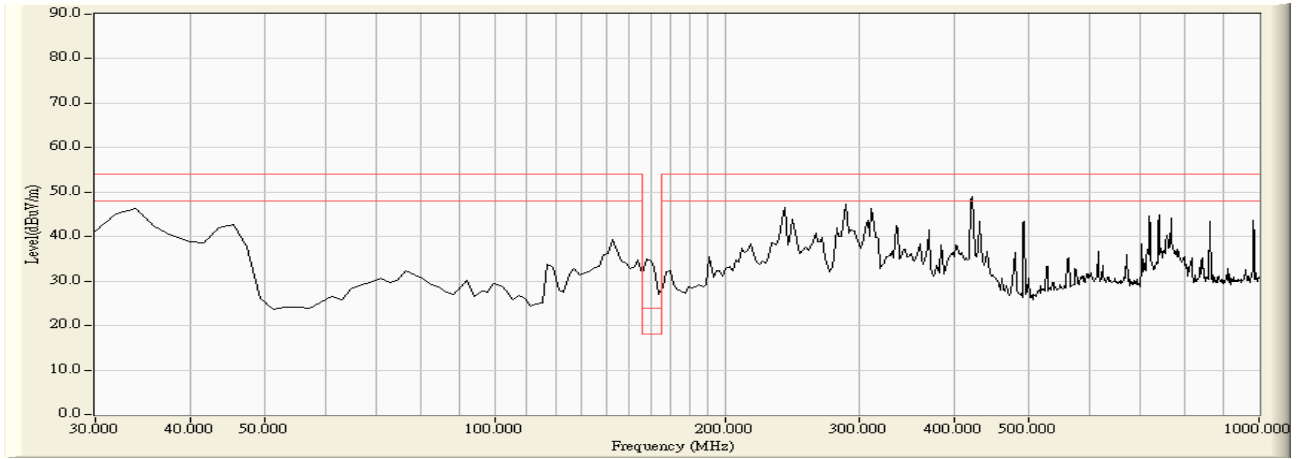

Site : CB7	Time : 2013/07/19 - 06:37
Limit : IEC_60945_30M-2G_00M_QP	Margin : 6
EUT : AIS Class B Transponder	Probe : CB7_CBL6112_1307 - VERTICAL
Power : DC 24V	Note : Mode 2

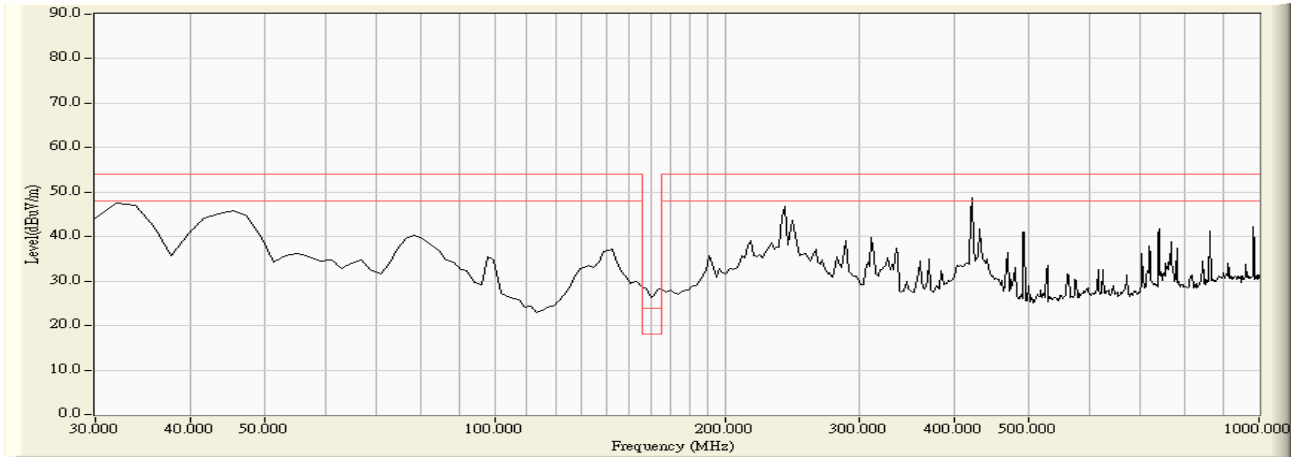

Site : Site7	Time : 2013/07/18 - 11:07
Limit : IEC60945_3M_QP	Margin : 6
EUT : AIS Class B Transponder	Probe : Site7_CBL6112_3M_1307 - HORIZONTAL
Power : DC 24V	Note : Mode 2

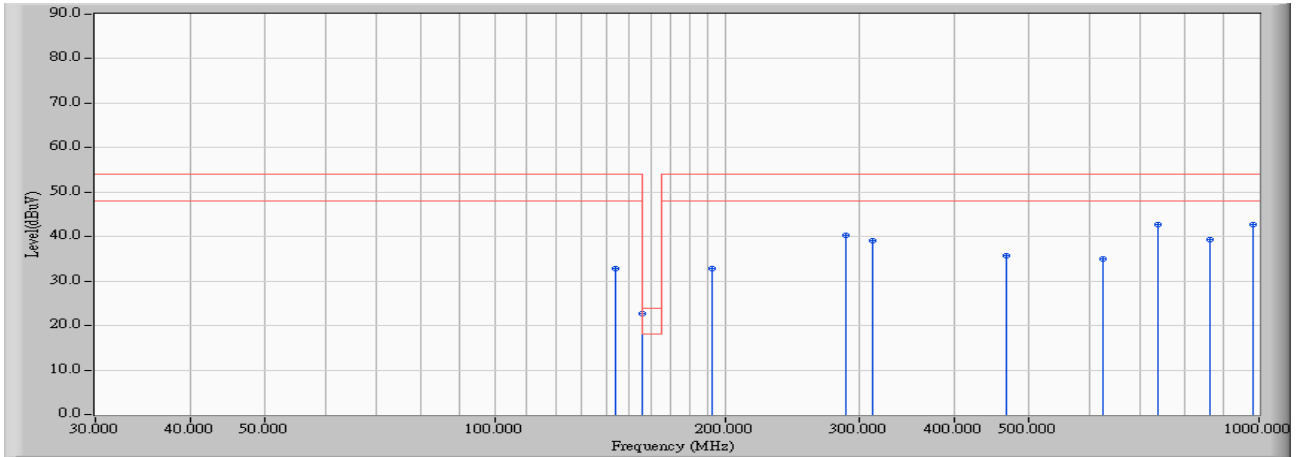

	Frequency (MHz)	Correct Factor (dB)	Reading Level (dBuV)	Measure Level (dBuV)	Margin (dB)	Limit (dBuV)	Detector Type
1	144.000	-18.316	51.240	32.924	-21.076	54.000	QUASIPeAK
2	* 156.010	-18.679	41.250	22.571	-1.429	24.000	QUASIPeAK
3	192.010	-19.258	52.140	32.882	-21.118	54.000	QUASIPeAK
4	288.000	-14.260	54.470	40.209	-13.791	54.000	QUASIPeAK
5	312.000	-13.339	52.400	39.062	-14.938	54.000	QUASIPeAK
6	468.010	-8.397	44.000	35.602	-18.398	54.000	QUASIPeAK
7	624.010	-5.362	40.300	34.938	-19.062	54.000	QUASIPeAK
8	739.010	-3.822	46.600	42.779	-11.221	54.000	QUASIPeAK
9	862.010	-1.660	40.900	39.240	-14.760	54.000	QUASIPeAK
10	982.010	-0.060	42.690	42.629	-11.371	54.000	QUASIPeAK

Note:

1. All Reading Levels are Quasi-Peak and average value.
2. " * ", means this data is the worst emission level.
3. Measurement Level = Reading Level + Correct Factor

Site : Site7	Time : 2013/07/18 - 11:08
Limit : IEC60945_3M_QP	Margin : 6
EUT : AIS Class B Transponder	Probe : Site7_CBL6112_3M_1307 - VERTICAL
Power : DC 24V	Note : Mode 2

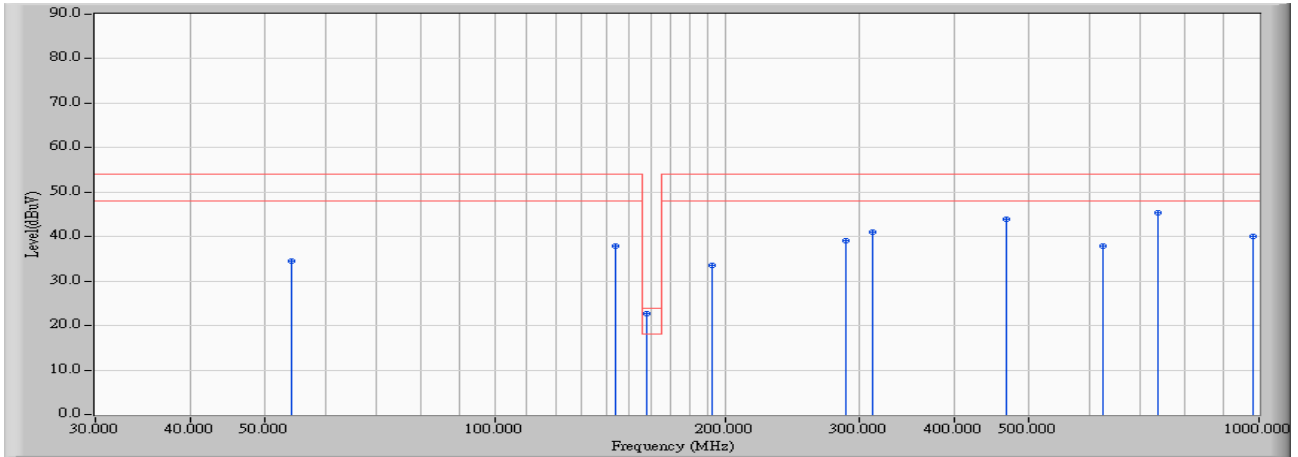

	Frequency (MHz)	Correct Factor (dB)	Reading Level (dBuV)	Measure Level (dBuV)	Margin (dB)	Limit (dBuV)	Detector Type
1	54.200	-22.498	56.990	34.492	-19.508	54.000	QUASIPeAK
2	144.010	-18.317	56.200	37.883	-16.117	54.000	QUASIPeAK
3	* 158.010	-18.689	41.300	22.610	-1.390	24.000	QUASIPeAK
4	192.010	-19.258	52.850	33.592	-20.408	54.000	QUASIPeAK
5	288.010	-14.260	53.310	39.050	-14.950	54.000	QUASIPeAK
6	312.010	-13.338	54.440	41.102	-12.898	54.000	QUASIPeAK
7	468.010	-8.397	52.400	44.002	-9.998	54.000	QUASIPeAK
8	624.010	-5.362	43.130	37.768	-16.232	54.000	QUASIPeAK
9	739.010	-3.822	49.100	45.279	-8.721	54.000	QUASIPeAK
10	982.010	-0.060	40.220	40.159	-13.841	54.000	QUASIPeAK

Note:

1. All Reading Levels are Quasi-Peak and average value.
2. " * ", means this data is the worst emission level.
3. Measurement Level = Reading Level + Correct Factor

Site : CB7	Time : 2013/09/27 - 16:26
Limit : IEC_60945_30M-2G_00M_QP	Margin : 6
EUT: AIS Class B Transponder	Probe : CB7_CBL6112_1307 - HORIZONTAL
Power : DC 24V	Note : Mode 2

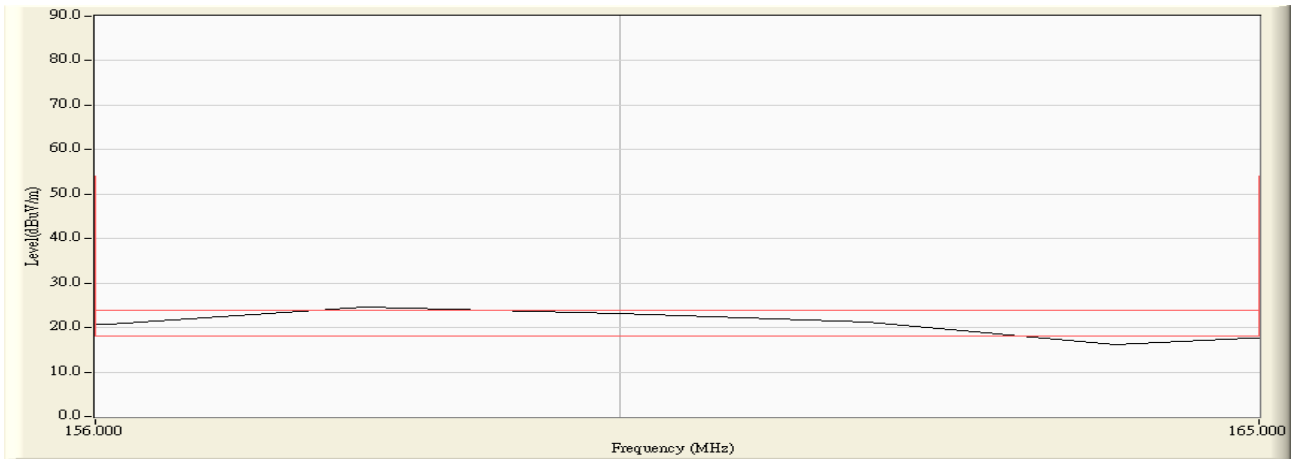

Site : CB7	Time : 2013/09/27 - 16:33
Limit : IEC_60945_30M-2G_00M_QP	Margin : 6
EUT: AIS Class B Transponder	Probe : CB7_CBL6112_1307 - VERTICAL
Power : DC 24V	Note : Mode 2

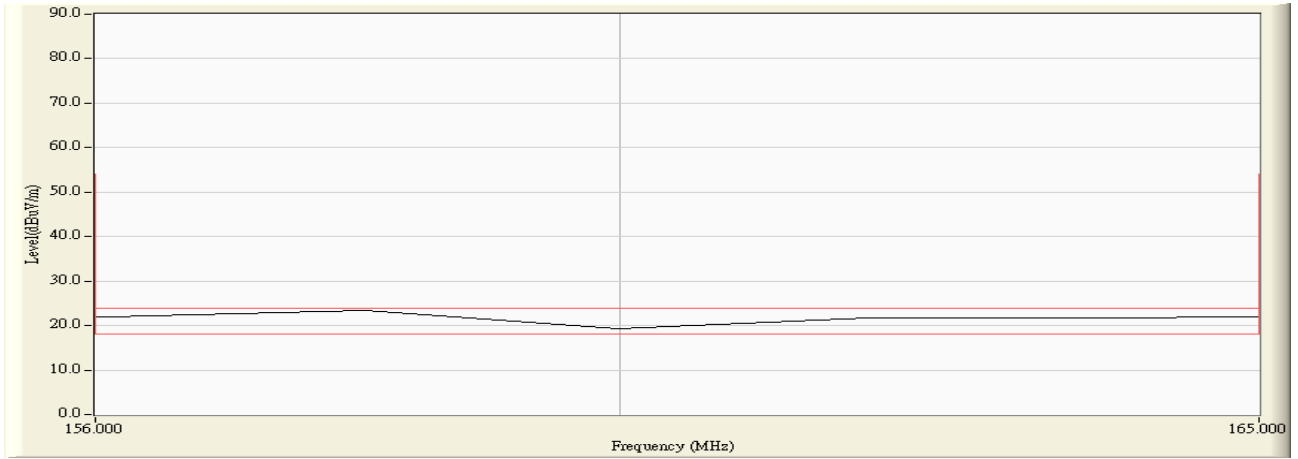

Site : Site7	Time : 2013/09/27 - 17:50
Limit : IEC60945_3M_QP	Margin : 6
EUT: AIS Class B Transponder	Probe : Site7_CBL6112_3M_1307 - HORIZONTAL
Power : DC 24V	Note : Mode 2

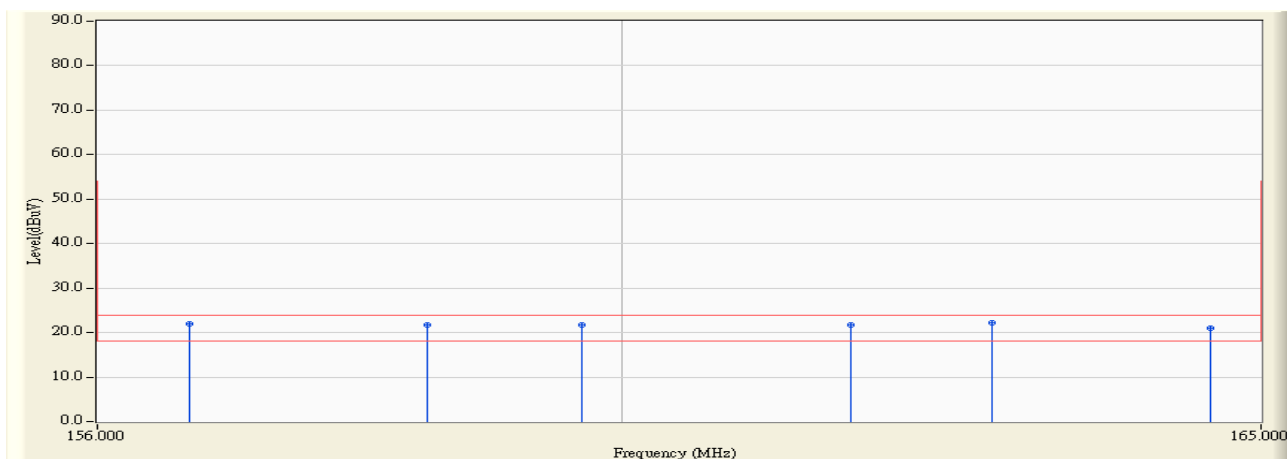

		Frequency (MHz)	Correct Factor (dB)	Reading Level (dBuV)	Measure Level (dBuV)	Margin (dB)	Limit (dBuV)	Detector Type
1		156.700	-18.680	40.700	22.020	-1.980	24.000	QUASIPeAK
2		158.500	-18.690	40.500	21.810	-2.190	24.000	QUASIPeAK
3		159.690	-18.697	40.320	21.623	-2.377	24.000	QUASIPeAK
4		161.770	-18.793	40.470	21.678	-2.322	24.000	QUASIPeAK
5	*	162.880	-18.839	41.100	22.260	-1.740	24.000	QUASIPeAK
6		164.600	-18.928	39.990	21.062	-2.938	24.000	QUASIPeAK

Note:

1. All Reading Levels are Quasi-Peak and average value.
2. " * ", means this data is the worst emission level.
3. Measurement Level = Reading Level + Correct Factor

Site : Site7	Time : 2013/09/27 - 18:06
Limit : IEC60945_3M_QP	Margin : 6
EUT: AIS Class B Transponder	Probe : Site7_CBL6112_3M_1307 - VERTICAL
Power : DC 24V	Note : Mode 2

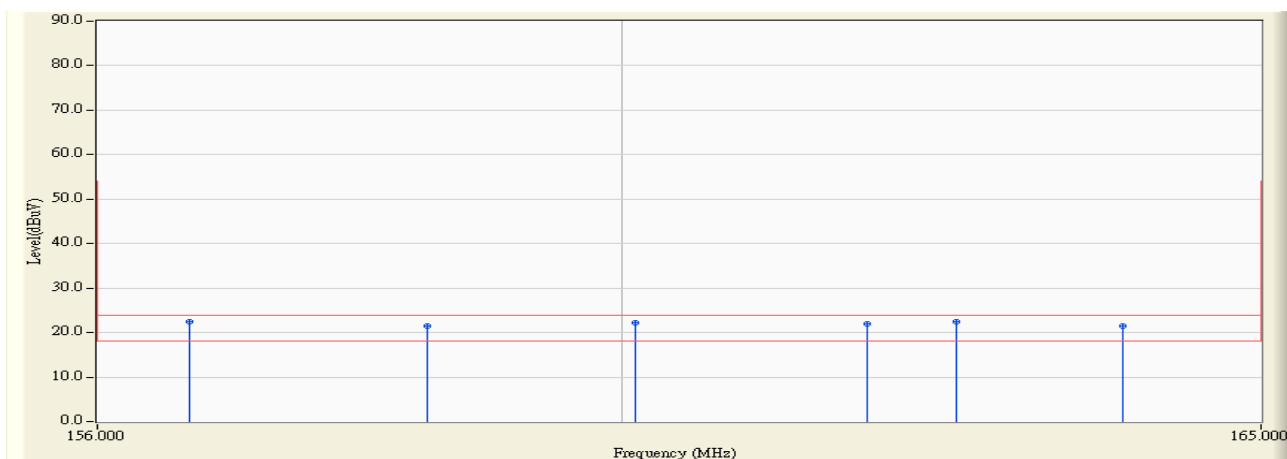

		Frequency (MHz)	Correct Factor (dB)	Reading Level (dBuV)	Measure Level (dBuV)	Margin (dB)	Limit (dBuV)	Detector Type
1	*	156.690	-18.680	41.200	22.520	-1.480	24.000	QUASIPeAK
2		158.500	-18.690	40.230	21.540	-2.460	24.000	QUASIPeAK
3		160.100	-18.706	41.000	22.294	-1.706	24.000	QUASIPeAK
4		161.900	-18.799	40.780	21.981	-2.019	24.000	QUASIPeAK
5		162.600	-18.828	41.230	22.402	-1.598	24.000	QUASIPeAK
6		163.900	-18.892	40.300	21.408	-2.592	24.000	QUASIPeAK

Note:

1. All Reading Levels are Quasi-Peak and average value.
2. " * ", means this data is the worst emission level.
3. Measurement Level = Reading Level + Correct Factor

Site: CB7	Time: 2013/07/18 - 05:23
Limit: IEC_60945_30M-2G_00M_QP	Margin: 6
Probe: CB7_Horn_9120D_1211	Polarity: Horizontal
EUT: AIS Class B Transponder	Power: DC 12V
Note : Mode 1	

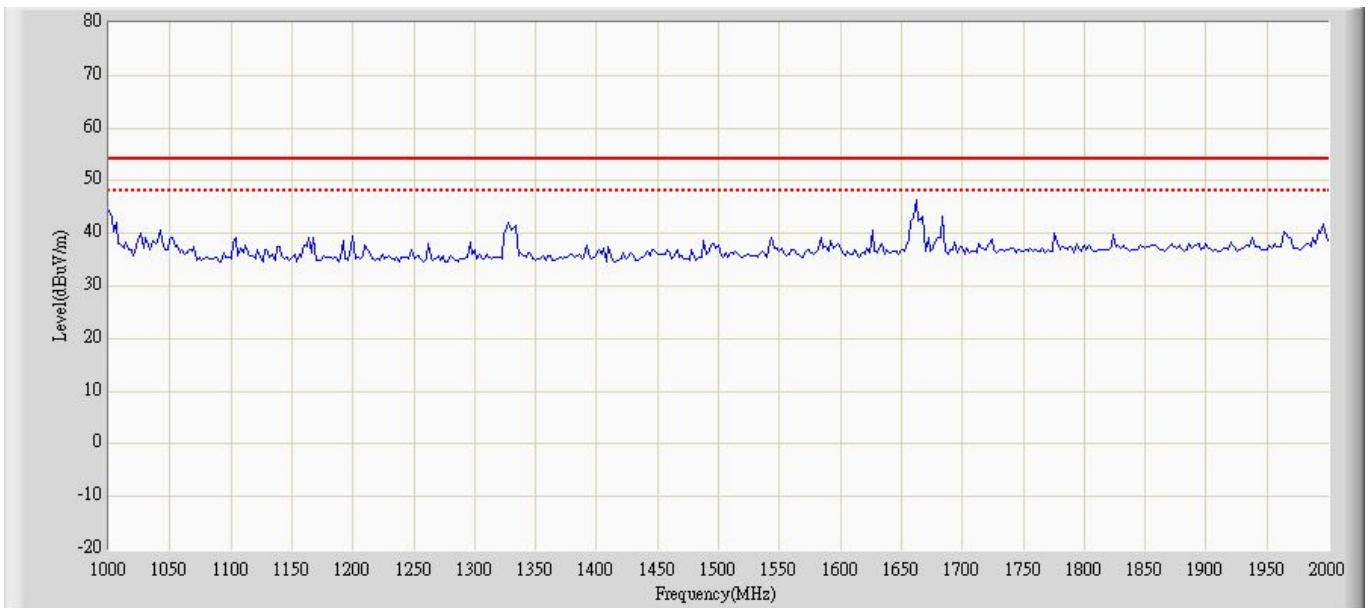

Site: CB7	Time: 2013/07/18 - 05:24
Limit: IEC_60945_30M-2G_00M_QP	Margin: 6
Probe: CB7_Horn_9120D_1211	Polarity: Vertical
EUT: AIS Class B Transponder	Power: DC 12V
Note : Mode 1	

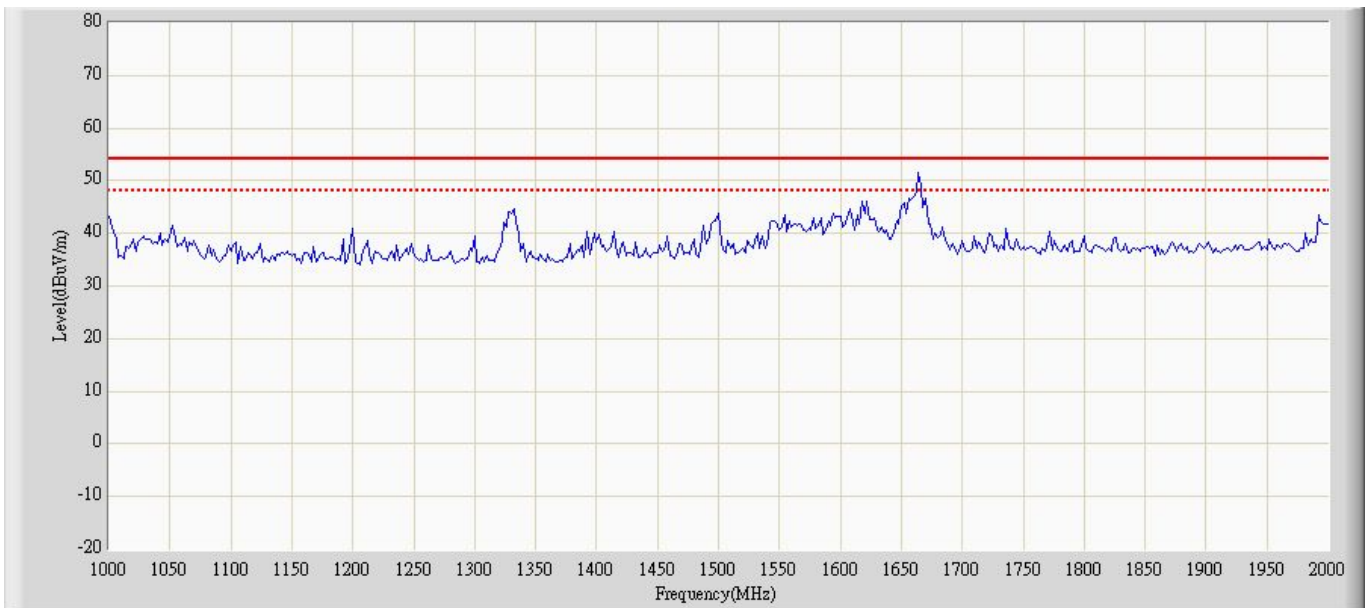

Site: CB7	Time: 2013/07/18 - 05:20
Limit: IEC_60945_30M-2G_00M_QP	Margin: 6
Probe: CB7_Horn_9120D_1211	Polarity: Horizontal
EUT: AIS Class B Transponder	Power: DC 12V
Note : Mode 1	

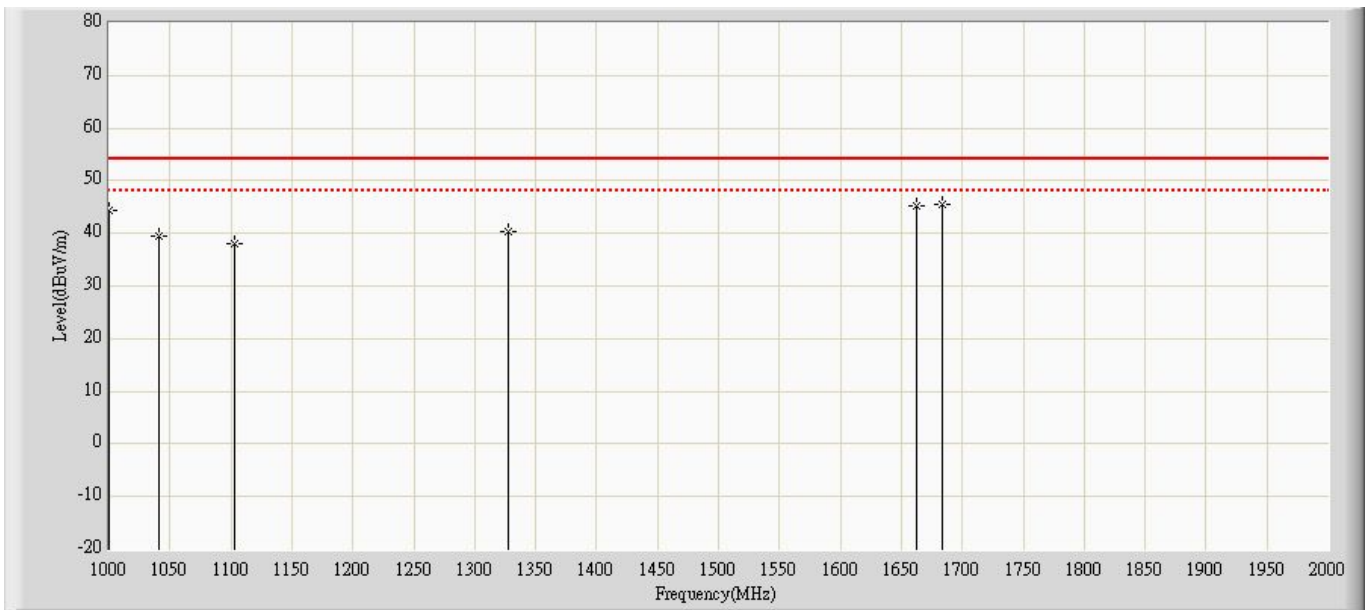

No	Flag	Mark	Frequency (MHz)	Measure Level (dBuV/m)	Reading Level (dBuV)	Over Limit (dB)	Limit (dBuV/m)	Factor	Type
1			1000.000	44.419	51.120	-9.581	54.000	-6.701	QP
2			1041.000	39.590	46.110	-14.410	54.000	-6.520	QP
3			1103.000	38.142	44.290	-15.858	54.000	-6.148	QP
4			1328.000	40.365	45.370	-13.635	54.000	-5.005	QP
5			1662.000	45.226	48.970	-8.774	54.000	-3.744	QP
6		*	1684.000	45.383	49.270	-8.617	54.000	-3.887	QP

Note:

1. All Readings below 1GHz are Quasi-Peak, above are performed with peak and/or average measurements as necessary.
2. " * ", means this data is the worst emission level.
3. Measurement Level = Reading Level + Factor(Probe+Cable-Amp).

Site: CB7	Time: 2013/07/18 - 05:25
Limit: IEC_60945_30M-2G_00M_QP	Margin: 6
Probe: CB7_Horn_9120D_1211	Polarity: Vertical
EUT: AIS Class B Transponder	Power: DC 12V
Note : Mode 1	

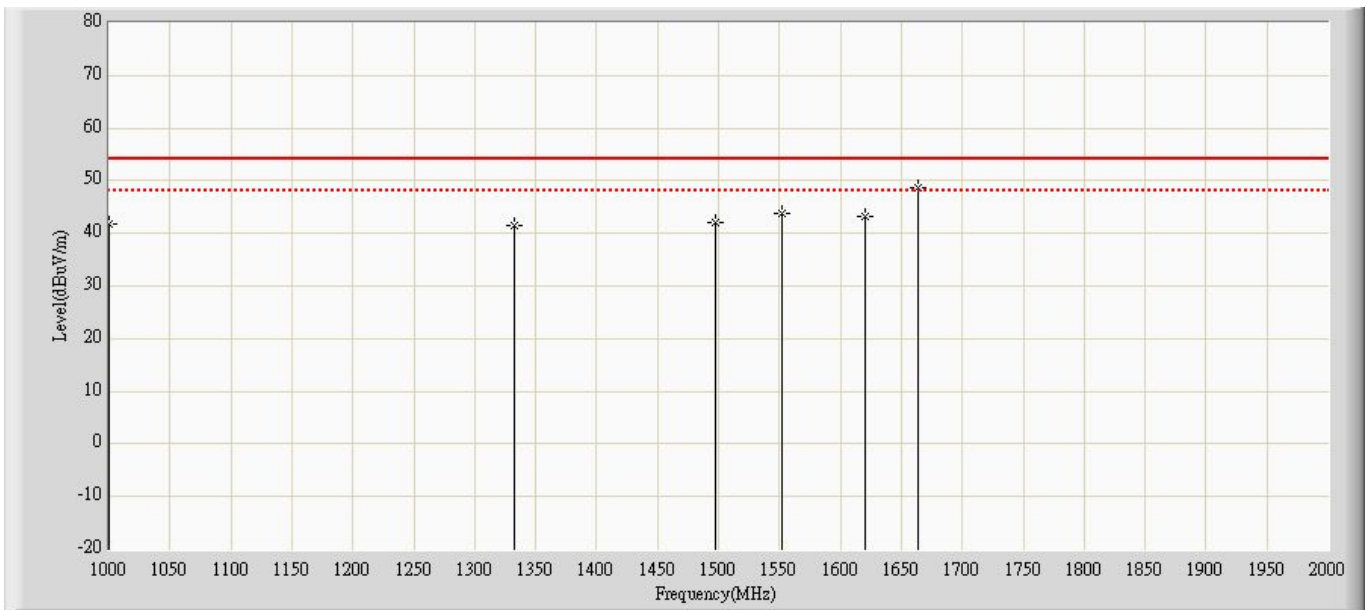

No	Flag	Mark	Frequency (MHz)	Measure Level (dBuV/m)	Reading Level (dBuV)	Over Limit (dB)	Limit (dBuV/m)	Factor	Type
1			1000.000	41.669	48.370	-12.331	54.000	-6.701	QP
2			1332.000	41.590	46.680	-12.410	54.000	-5.090	QP
3			1498.000	42.167	46.680	-11.833	54.000	-4.513	QP
4			1552.000	43.702	48.160	-10.298	54.000	-4.459	QP
5			1620.000	43.202	47.370	-10.798	54.000	-4.169	QP
6		*	1664.000	48.632	52.330	-5.368	54.000	-3.698	QP

Note:

1. All Readings below 1GHz are Quasi-Peak, above are performed with peak and/or average measurements as necessary.
2. " * ", means this data is the worst emission level.
3. Measurement Level = Reading Level + Factor(Probe+Cable-Amp).

Site: CB7	Time: 2013/07/18 - 04:42
Limit: IEC_60945_30M-2G_00M_QP	Margin: 6
Probe: CB7_Horn_9120D_1211	Polarity: Horizontal
EUT: AIS Class B Transponder	Power: DC 24V
Note : Mode 2	

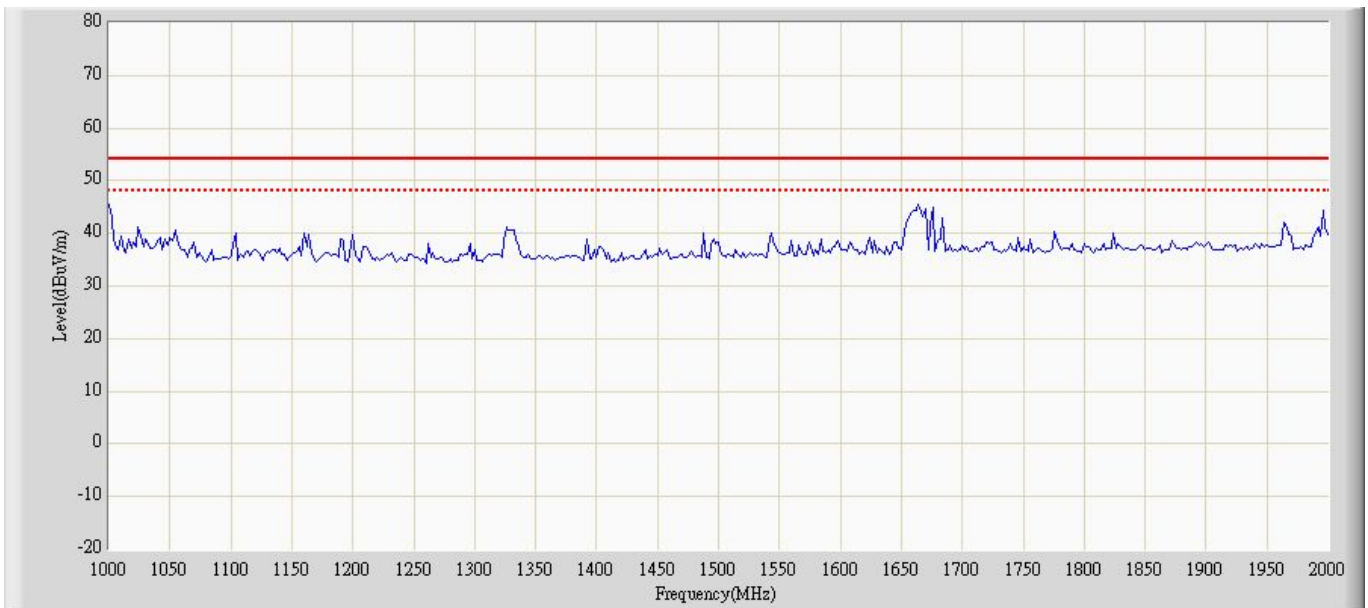

Site: CB7	Time: 2013/07/18 - 04:49
Limit: IEC_60945_30M-2G_00M_QP	Margin: 6
Probe: CB7_Horn_9120D_1211	Polarity: Vertical
EUT: AIS Class B Transponder	Power: DC 24V
Note : Mode 2	

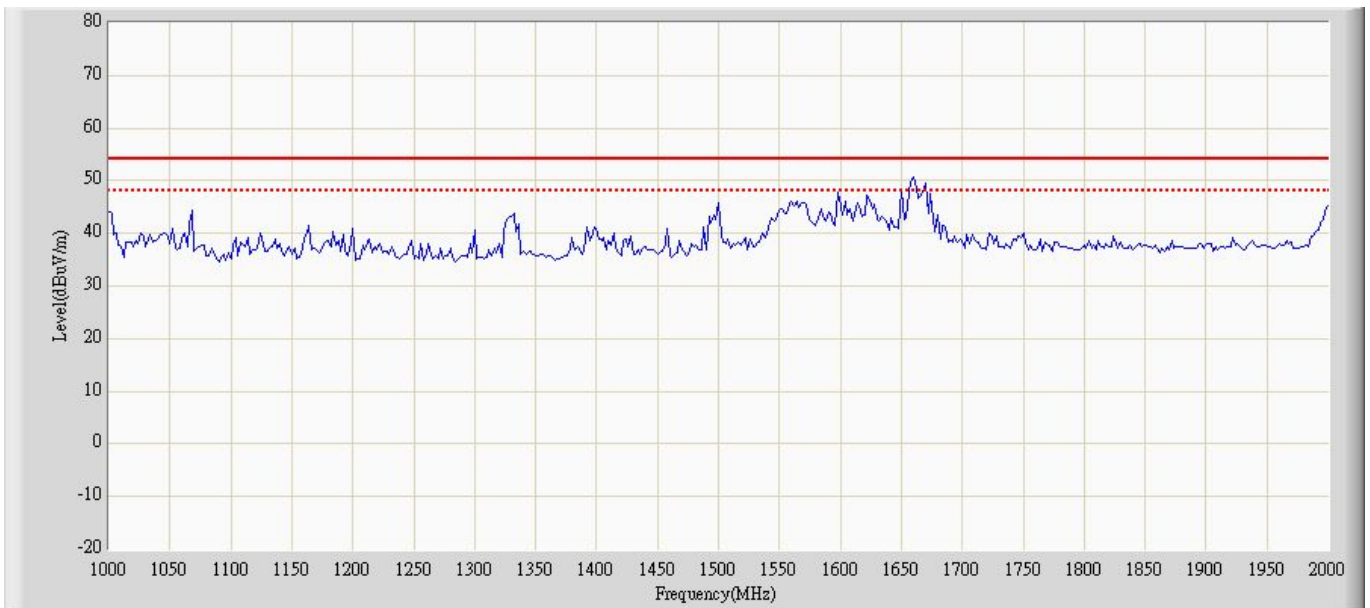

Site: CB7	Time: 2013/07/18 - 04:43
Limit: IEC_60945_30M-2G_00M_QP	Margin: 6
Probe: CB7_Horn_9120D_1211	Polarity: Horizontal
EUT: AIS Class B Transponder	Power: DC 24V
Note : Mode 2	

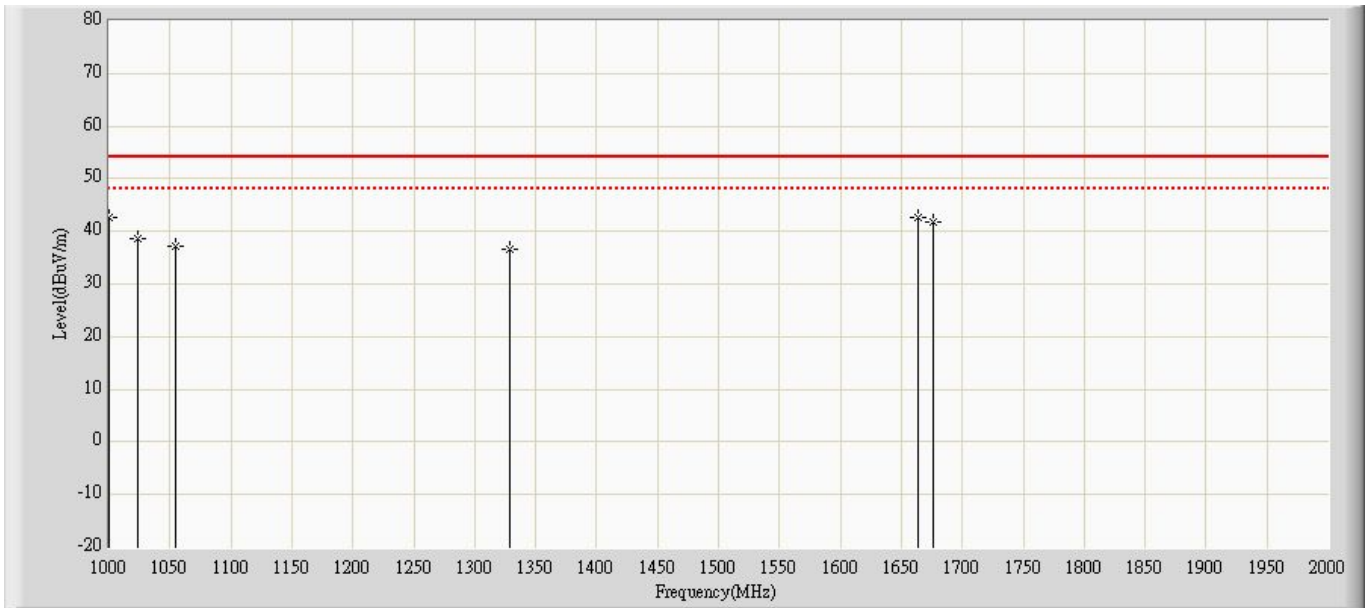

No	Flag	Mark	Frequency (MHz)	Measure Level (dBuV/m)	Reading Level (dBuV)	Over Limit (dB)	Limit (dBuV/m)	Factor	Type
1			1000.000	42.679	49.380	-11.321	54.000	-6.701	QP
2			1023.000	38.636	45.270	-15.364	54.000	-6.633	QP
3			1054.000	37.215	43.610	-16.785	54.000	-6.395	QP
4			1329.000	36.644	41.670	-17.356	54.000	-5.027	QP
5		*	1664.000	42.682	46.380	-11.318	54.000	-3.698	QP
6			1676.000	41.830	45.630	-12.170	54.000	-3.800	QP

Note:

1. All Readings below 1GHz are Quasi-Peak, above are performed with peak and/or average measurements as necessary.
2. " * ", means this data is the worst emission level.
3. Measurement Level = Reading Level + Factor(Probe+Cable-Amp).

Site: CB7	Time: 2013/07/18 - 04:47
Limit: IEC_60945_30M-2G_00M_QP	Margin: 6
Probe: CB7_Horn_9120D_1211	Polarity: Vertical
EUT: AIS Class B Transponder	Power: DC 24V
Note : Mode 2	

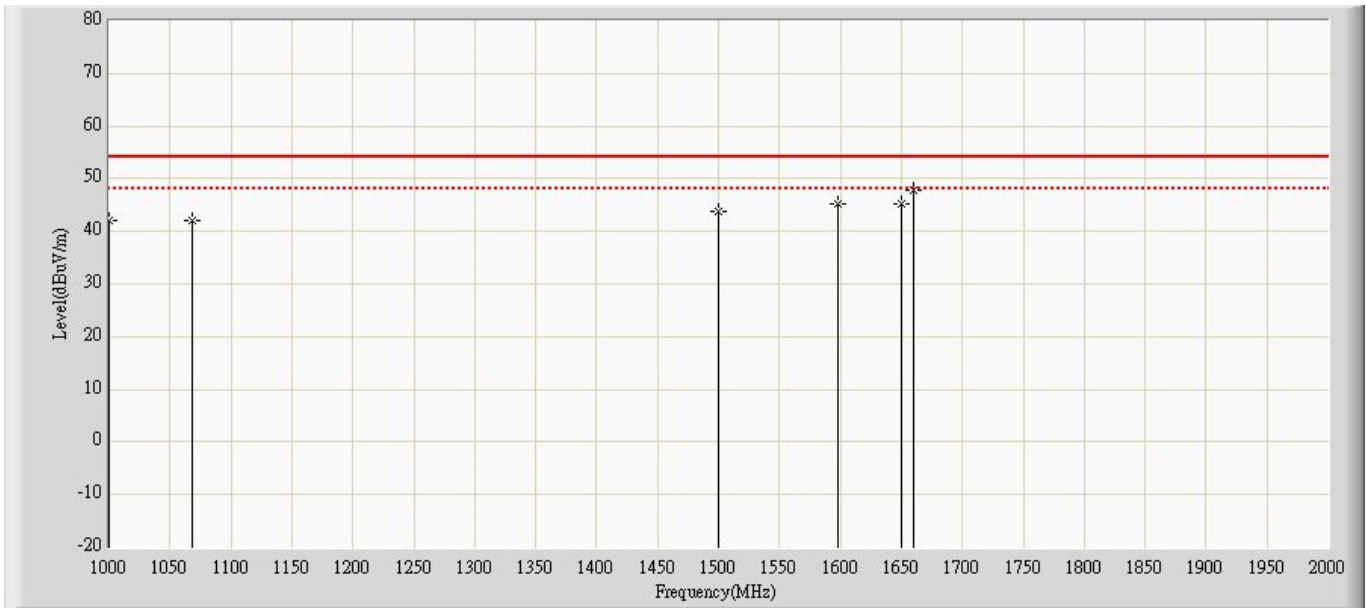

No	Flag	Mark	Frequency (MHz)	Measure Level (dBuV/m)	Reading Level (dBuV)	Over Limit (dB)	Limit (dBuV/m)	Factor	Type
1			1000.000	42.209	48.910	-11.791	54.000	-6.701	QP
2			1068.000	42.000	48.520	-12.000	54.000	-6.520	QP
3			1500.000	43.783	48.270	-10.217	54.000	-4.487	QP
4			1598.000	45.221	49.340	-8.779	54.000	-4.119	QP
5			1650.000	45.355	49.380	-8.645	54.000	-4.025	QP
6		*	1660.000	47.809	51.600	-6.191	54.000	-3.791	QP

Note:

1. All Readings below 1GHz are Quasi-Peak, above are performed with peak and/or average measurements as necessary.
2. " * ", means this data is the worst emission level.
3. Measurement Level = Reading Level + Factor(Probe+Cable-Amp).

4.7. Test Photograph

Test Mode : Mode 1: DC 12V

Description : Front View of Radiated Test-Loop

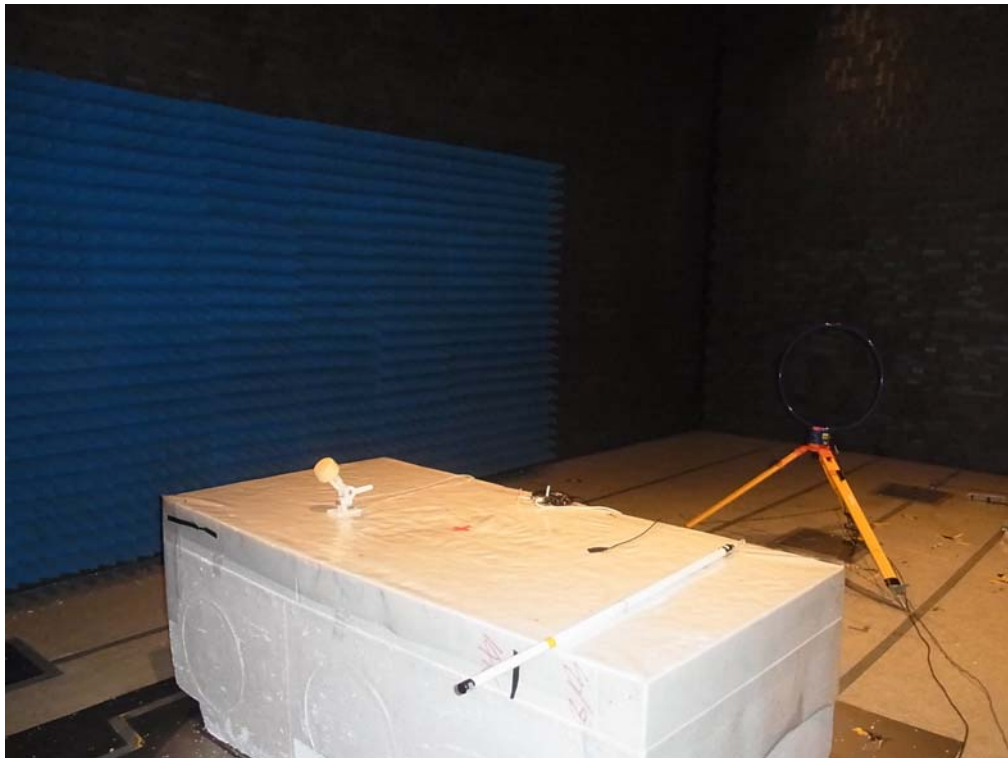

Test Mode : Mode 1: DC 12V

Description : Back View of Radiated Test-Loop

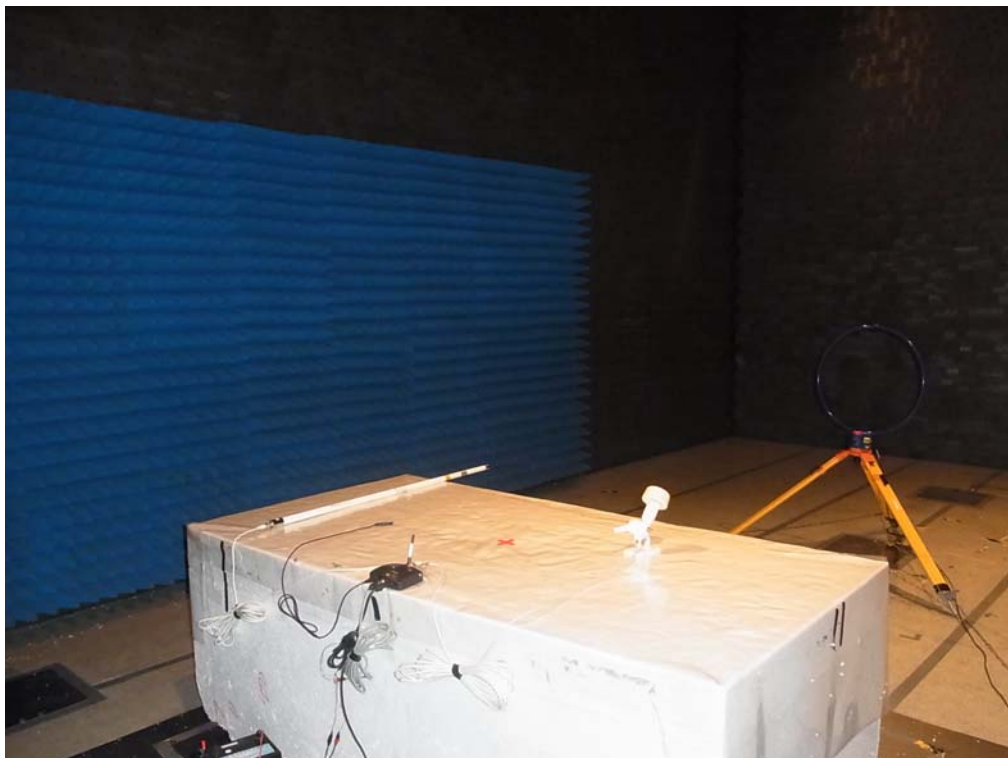

Test Mode : Mode 1: DC 12V

Description : Front View of Radiated Test



Test Mode : Mode 1: DC 12V

Description : Back View of Radiated Test



Test Mode : Mode 1: DC 12V

Description : Front View of High Frequency Radiated Test



Test Mode : Mode 2: DC 24V

Description : Front View of Radiated Test-Loop



Test Mode : Mode 2: DC 24V

Description : Back View of Radiated Test-Loop



Test Mode : Mode 2: DC 24V

Description : Front View of Radiated Test



Test Mode : Mode 2: DC 24V

Description : Back View of Radiated Test



Test Mode : Mode 2: DC 24V

Description : Front View of High Frequency Radiated Test



5. Conducted Radio Frequency Disturbance

5.1. Test Specification

According to Standard : IEC 60945

5.2. Test Setup

CDN Test Mode

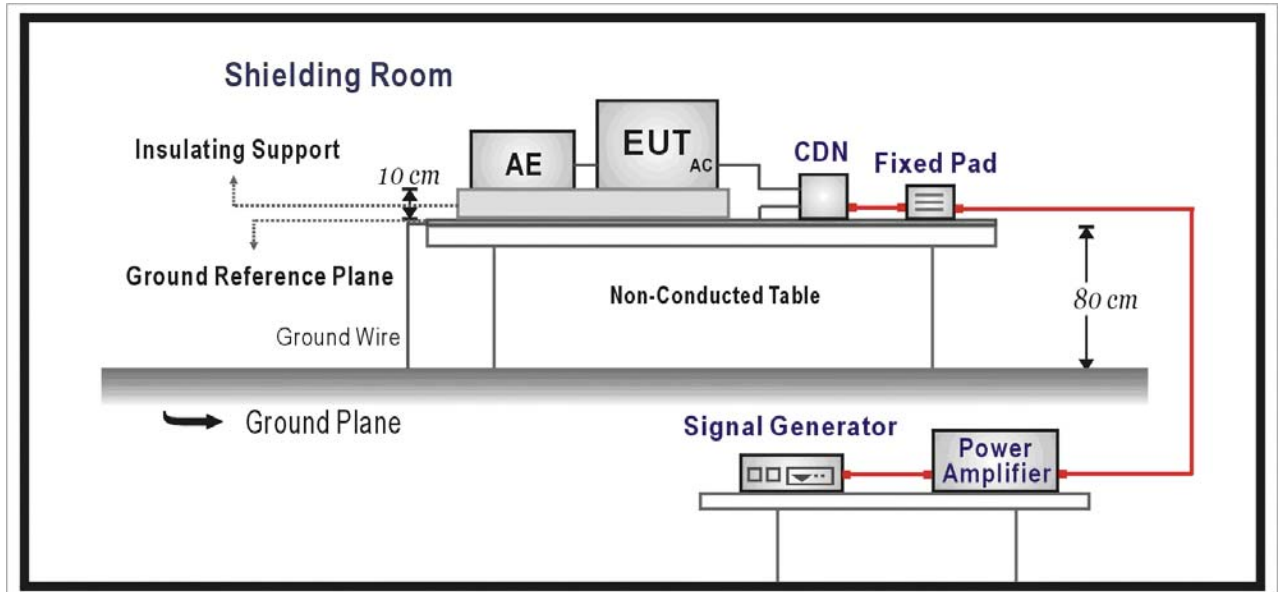

EM Clamp Test Mode

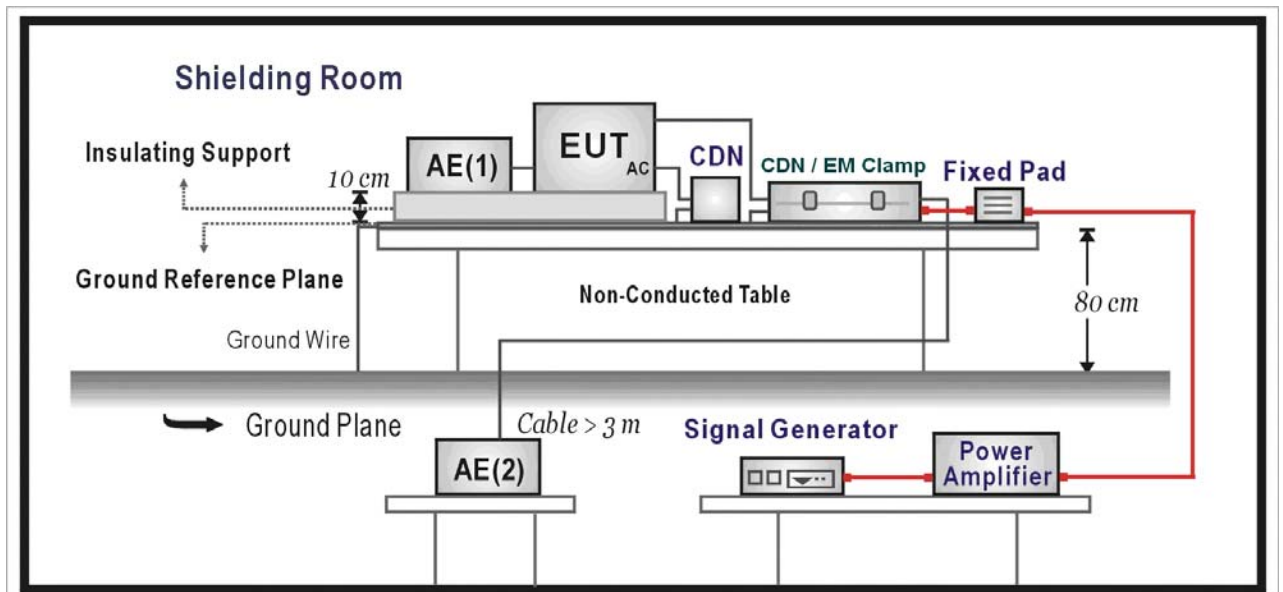

5.3. Limit

Item	Environmental Phenomena	Units	Test Specification	Performance Criteria
Signal Ports and Telecommunication Ports				
Radio-Frequency Continuous Conducted		MHz V (rms, Un-modulated) % AM (400Hz)	0.15-80 3,10 80	A
Input DC Power Ports				
Radio-Frequency Continuous Conducted		MHz V (rms, Un-modulated) % AM (400Hz)	0.15-80 3,10 80	A
Input AC Power Ports				
Radio-Frequency Continuous Conducted		MHz V (rms, Un-modulated) % AM (400Hz)	0.15-80 3,10 80	A

5.4. Test Procedure

The EUT are placed on a table that is 0.8 meter height, and a Ground reference plane on the table, EUT are placed upon table and use a 10cm insulation between the EUT and Ground reference plane.

For Signal Ports and Telecommunication Ports

The disturbance signal is through a coupling and decoupling networks (CDN) or EM-clamp device couples to the signal and Telecommunication lines of the EUT.

For Input DC and AC Power Ports

The EUT is connected to the power mains through a coupling and decoupling networks for power supply lines. And directly couples the disturbances signal into EUT.

Used CDN-M2 for two wires or CDN-M3 for three wires.

All the scanning conditions are as follows:

Condition of Test	Remarks
1. Field Strength	3V Level 2, 10V Level 3
2. Radiated Signal	AM 80% Modulated with 400Hz
3. Scanning Frequency	0.15MHz – 80MHz for 3V(rms) 2,3,4,6.2,8.2,12.6,16.5,18.8,22,25MHz for 10V(rms)
4 Dwell Time	2.86 Seconds
5. Frequency step size Δf	1%
6. The rate of Swept of Frequency	1.5×10^{-3} decades/s or 1% / 3 Seconds

Note: Tolerances

Amplitude $\pm 10\%$

5.5. Deviation from Test Standard

No deviation.

5.6. Test Result

Product	AIS Class B Transponder		
Test Item	Conducted susceptibility		
Test Mode	Mode 1: DC 12V		
Date of Test	2013/07/09	Test Site	No.6 Shielded Room

Frequency Range (MHz)	Voltage Applied dBuV(V)	Inject Method	Tested Port of EUT	Required Criteria	Performance Criteria Complied To	Result
DC Power Line (AM 80% Modulated with 400Hz)						
0.15~80	3V	CDN	Power 12V	A	A	PASS
2	10V	CDN	Power 12V	A	A	PASS
3	10V	CDN	Power 12V	A	A	PASS
4	10V	CDN	Power 12V	A	A	PASS
6.2	10V	CDN	Power 12V	A	A	PASS
8.2	10V	CDN	Power 12V	A	A	PASS
12.6	10V	CDN	Power 12V	A	A	PASS
16.5	10V	CDN	Power 12V	A	A	PASS
18.8	10V	CDN	Power 12V	A	A	PASS
22	10V	CDN	Power 12V	A	A	PASS
25	10V	CDN	Power 12V	A	A	PASS

Note:

- Meet criteria A : Operate as intended during and after the test
- Meet criteria B : Operate as intended after the test
- Meet criteria C : Loss/Error of function
- Additional Information
 - EUT stopped operation and could / could not be reset by operator at _____ dBuV(V) at frequency _____ MHz.
 - No false alarms or other malfunctions were observed during or after the test. The acceptance criteria were met, and the EUT passed the test.

Product	AIS Class B Transponder		
Test Item	Conducted susceptibility		
Test Mode	Mode 1: DC 12V		
Date of Test	2013/07/09	Test Site	No.6 Shielded Room

Frequency Range (MHz)	Voltage Applied dBuV(V)	Inject Method	Tested Port of EUT	Required Criteria	Performance Criteria Complied To	Result
Signal Line (AM 80% Modulated with 400Hz)						
0.15~80	3V	Clamp	Communication Port (VHF,GPS,NMEA0183,NMEA2000,USB)	A	A	PASS
2	10V	Clamp	Communication Port (VHF,GPS,NMEA0183,NMEA2000,USB)	A	A	PASS
3	10V	Clamp	Communication Port (VHF,GPS,NMEA0183,NMEA2000,USB)	A	A	PASS
4	10V	Clamp	Communication Port (VHF,GPS,NMEA0183,NMEA2000,USB)	A	A	PASS
6.2	10V	Clamp	Communication Port (VHF,GPS,NMEA0183,NMEA2000,USB)	A	A	PASS
8.2	10V	Clamp	Communication Port (VHF,GPS,NMEA0183,NMEA2000,USB)	A	A	PASS
12.6	10V	Clamp	Communication Port (VHF,GPS,NMEA0183,NMEA2000,USB)	A	A	PASS
16.5	10V	Clamp	Communication Port (VHF,GPS,NMEA0183,NMEA2000,USB)	A	A	PASS
18.8	10V	Clamp	Communication Port (VHF,GPS,NMEA0183,NMEA2000,USB)	A	A	PASS
22	10V	Clamp	Communication Port (VHF,GPS,NMEA0183,NMEA2000,USB)	A	A	PASS
25	10V	Clamp	Communication Port (VHF,GPS,NMEA0183,NMEA2000,USB)	A	A	PASS

Note:

- Meet criteria A : Operate as intended during and after the test
- Meet criteria B : Operate as intended after the test
- Meet criteria C : Loss/Error of function
- Additional Information

- EUT stopped operation and could / could not be reset by operator at _____ dBuV(V) at frequency _____MHz.
- No false alarms or other malfunctions were observed during or after the test. The acceptance criteria were met, and the EUT passed the test.

Test Record of Conducted Susceptibility

On the screenshot below, the transmitting packet quantity (of the additional AIS transponder) is marked by “Tx-packet” which is 716 (358 plus 358). The receiving packet quantity of the EUT is marked by “Rx-packet” which is 714 (357 plus 357).

Therefore, the PER (Packet Error Rate) of the EUT receiving performance under this test is 0.28%.

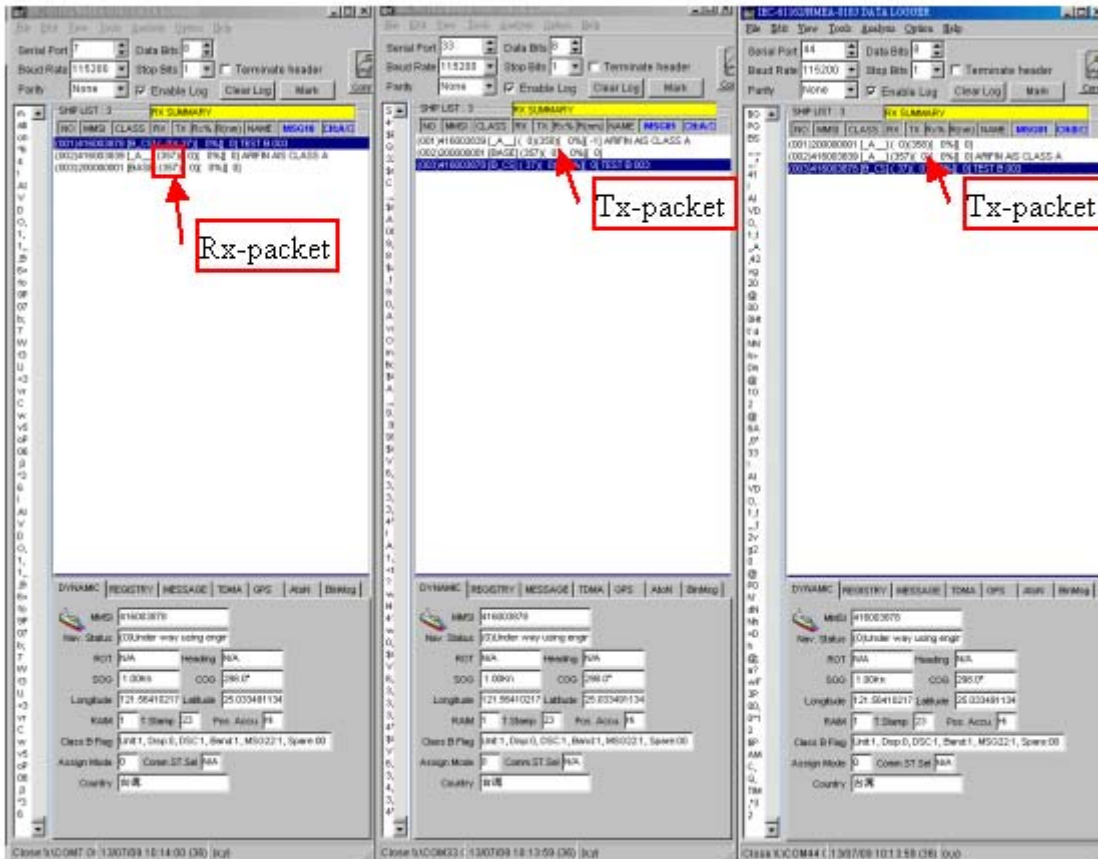

Product	AIS Class B Transponder		
Test Item	Conducted susceptibility		
Test Mode	Mode 2: DC 24V		
Date of Test	2013/07/09	Test Site	No.6 Shielded Room

Frequency Range (MHz)	Voltage Applied dBuV(V)	Inject Method	Tested Port of EUT	Required Criteria	Performance Criteria Complied To	Result
DC Power Line (AM 80% Modulated with 400Hz)						
0.15~80	3V	CDN	Power 24V	A	A	PASS
2	10V	CDN	Power 24V	A	A	PASS
3	10V	CDN	Power 24V	A	A	PASS
4	10V	CDN	Power 24V	A	A	PASS
6.2	10V	CDN	Power 24V	A	A	PASS
8.2	10V	CDN	Power 24V	A	A	PASS
12.6	10V	CDN	Power 24V	A	A	PASS
16.5	10V	CDN	Power 24V	A	A	PASS
18.8	10V	CDN	Power 24V	A	A	PASS
22	10V	CDN	Power 24V	A	A	PASS
25	10V	CDN	Power 24V	A	A	PASS

Note:

- Meet criteria A : Operate as intended during and after the test
- Meet criteria B : Operate as intended after the test
- Meet criteria C : Loss/Error of function
- Additional Information
 - EUT stopped operation and could / could not be reset by operator at ____ dBuV(V) at frequency ____MHz.
 - No false alarms or other malfunctions were observed during or after the test. The acceptance criteria were met, and the EUT passed the test.

Product	AIS Class B Transponder		
Test Item	Conducted susceptibility		
Test Mode	Mode 2: DC 24V		
Date of Test	2013/07/09	Test Site	No.6 Shielded Room

Frequency Range (MHz)	Voltage Applied dBuV(V)	Inject Method	Tested Port of EUT	Required Criteria	Performance Criteria Complied To	Result
Signal Line (AM 80% Modulated with 400Hz)						
0.15~80	3V	Clamp	Communication Port (VHF,GPS,NMEA0183,NMEA2000,USB)	A	A	PASS
2	10V	Clamp	Communication Port (VHF,GPS,NMEA0183,NMEA2000,USB)	A	A	PASS
3	10V	Clamp	Communication Port (VHF,GPS,NMEA0183,NMEA2000,USB)	A	A	PASS
4	10V	Clamp	Communication Port (VHF,GPS,NMEA0183,NMEA2000,USB)	A	A	PASS
6.2	10V	Clamp	Communication Port (VHF,GPS,NMEA0183,NMEA2000,USB)	A	A	PASS
8.2	10V	Clamp	Communication Port (VHF,GPS,NMEA0183,NMEA2000,USB)	A	A	PASS
12.6	10V	Clamp	Communication Port (VHF,GPS,NMEA0183,NMEA2000,USB)	A	A	PASS
16.5	10V	Clamp	Communication Port (VHF,GPS,NMEA0183,NMEA2000,USB)	A	A	PASS
18.8	10V	Clamp	Communication Port (VHF,GPS,NMEA0183,NMEA2000,USB)	A	A	PASS
22	10V	Clamp	Communication Port (VHF,GPS,NMEA0183,NMEA2000,USB)	A	A	PASS
25	10V	Clamp	Communication Port (VHF,GPS,NMEA0183,NMEA2000,USB)	A	A	PASS

Note:

- Meet criteria A : Operate as intended during and after the test
- Meet criteria B : Operate as intended after the test
- Meet criteria C : Loss/Error of function

Additional Information

- EUT stopped operation and could / could not be reset by operator at _____ dBuV(V) at frequency _____MHz.
- No false alarms or other malfunctions were observed during or after the test. The acceptance criteria were met, and the EUT passed the test.

Test Record Conducted Susceptibility

On the screenshot below, the transmitting packet quantity (of the additional AIS transponder) is marked by "Tx-packet" which is 713 (357 plus 356). The receiving packet quantity of the EUT is marked by "Rx-packet" which is 712 (356 plus 356).

Therefore, the PER (Packet Error Rate) of the EUT receiving performance under this test is 0.14%.

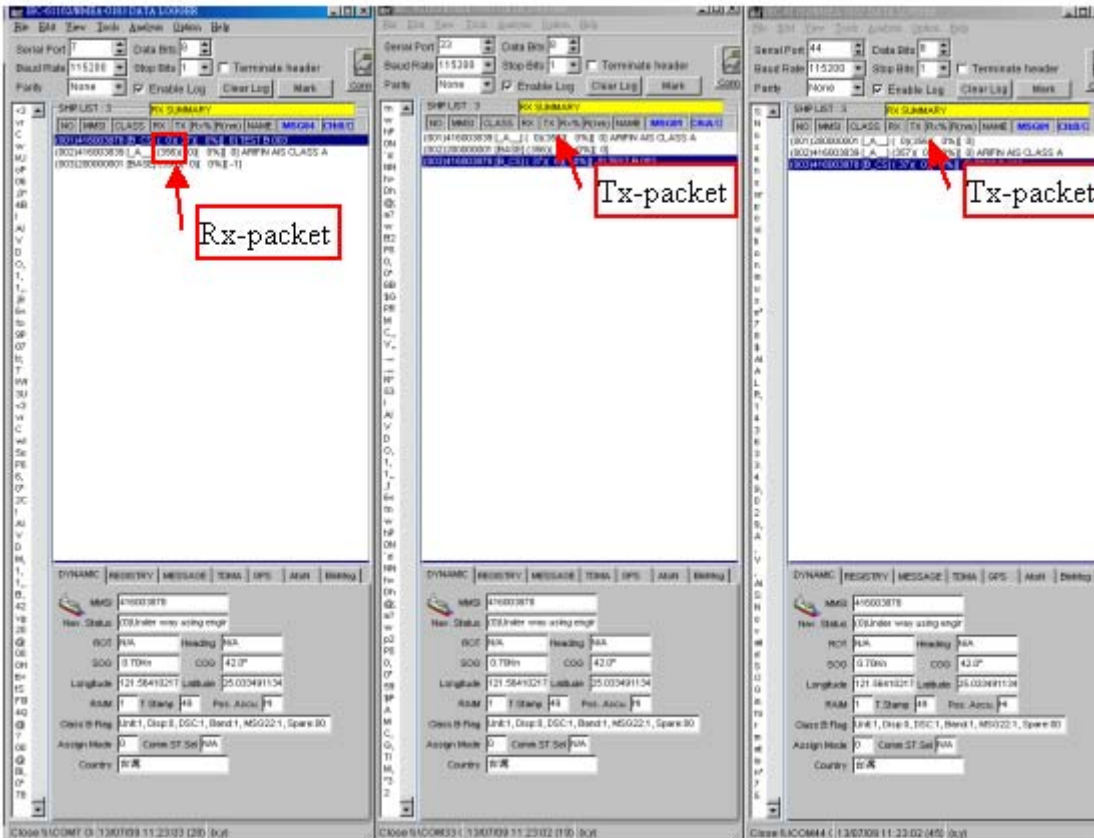

5.7. Test Photograph

Test Mode : Mode 1: DC 12V

Description : Conducted Susceptibility Test Setup



Test Mode : Mode 1: DC 12V

Description : Conducted Susceptibility Test Setup-Clamp



Test Mode : Mode 2: DC 24V

Description : Conducted Susceptibility Test Setup



Test Mode : Mode 2: DC 24V

Description : Conducted Susceptibility Test Setup-Clamp



6. Radiated Radio Frequencies

6.1. Test Specification

According to Standard : IEC 60945

6.2. Test Setup

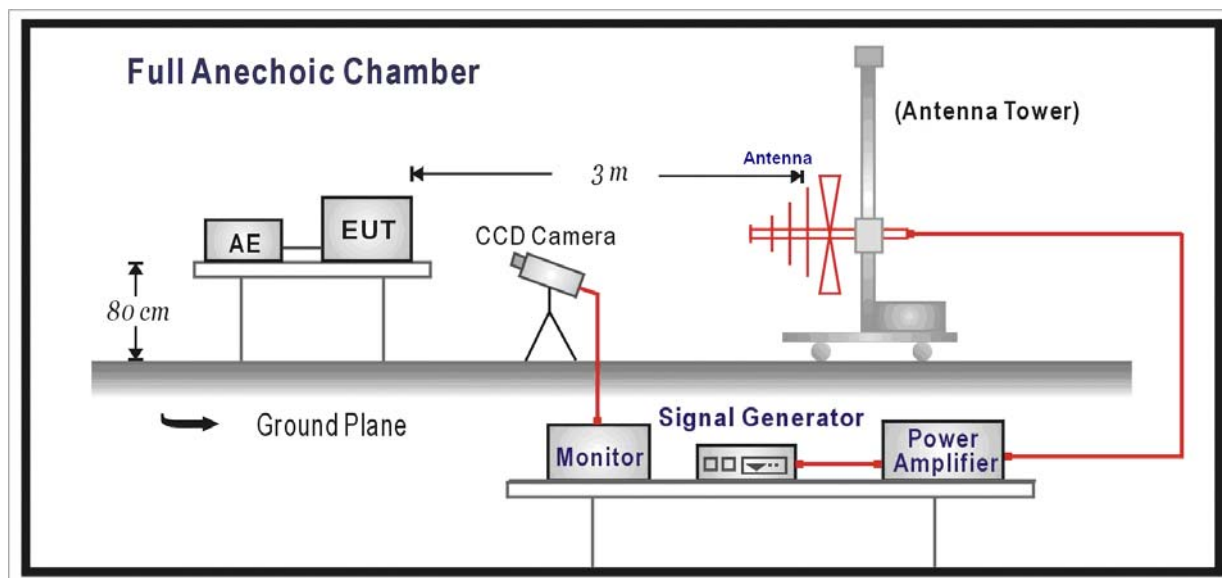

6.3. Limit

Item	Environmental Phenomena	Units	Test Specification	Performance Criteria
Enclosure Port				
	Radio-Frequency	MHz	80-2000	A
	Electromagnetic Field	V/m(Un-modulated, rms)	10	
	Amplitude Modulated	% AM (400Hz & 1kHz)	80	

6.4. Test Procedure

The EUT and load, which are placed on a table that is 0.8 meter above ground, are placed with one coincident with the calibration plane such that the distance from antenna to the EUT was 3 meters.

Both horizontal and vertical polarization of the antenna and four sides of the EUT are set on measurement.

In order to judge the EUT performance, a CCD camera is used to monitor EUT screen.

All the scanning conditions are as follows:

Condition of Test	Remarks
1. Field Strength	10 V/m Level 3
2. Radiated Signal	AM 80% Modulated with 400Hz
3. Scanning Frequency	80MHz - 2000MHz
4. Dwell Time	2.86 Seconds
5. Frequency step size Δf	1%
6. The rate of Swept of Frequency	1.5 x 10 ⁻³ decades/s or 1% / 3 Seconds 0.5 x 10 ⁻³ decades/s for the frequency range 1GHz to 2GHz

Note: Tolerances

Electric field strength -0/+6dB

6.5. Deviation from Test Standard

No deviation.

6.6. Test Result

Product	AIS Class B Transponder		
Test Item	Radiated susceptibility		
Test Mode	Mode 1: DC 12V		
Date of Test	2013/07/03	Test Site	Chamber 5

Frequency (MHz)	Position (Angle)	Polarity (H or V)	Field Strength (V/m)	Required Criteria	Complied To Criteria (A,B,C)	Results
AM 80% Modulated with 400Hz						
80-2000	0°	H	10	A	A	PASS
80-2000	0°	V	10	A	A	PASS
80-2000	90°	H	10	A	A	PASS
80-2000	90°	V	10	A	A	PASS
80-2000	180°	H	10	A	A	PASS
80-2000	180°	V	10	A	A	PASS
80-2000	270°	H	10	A	A	PASS
80-2000	270°	V	10	A	A	PASS

Note:

The testing performed is from lowest level up to the highest level as required by standard, but only highest level is shown on the report.

- Meet criteria A: Operate as intended during and after the test
- Meet criteria B: Operate as intended after the test
- Meet criteria C: Loss/Error of function
- Additional Information
 - There was no observable degradation in performance.
 - EUT stopped operation and could / could not be reset by operator at _____ V/m at frequency _____MHz.
- No false alarms or other malfunctions were observed during or after the test.

Test Record of Radiated Susceptibility

On the screenshot below, the transmitting packet quantity (of the additional AIS transponder) is marked by “Tx-packet” which is 4326 (2163 plus 2163). The receiving packet quantity of the EUT is marked by “Rx-packet” which is 4313 (2156 plus 2157). Therefore, the PER (Packet Error Rate) of the EUT receiving performance under this test is 0.30%.

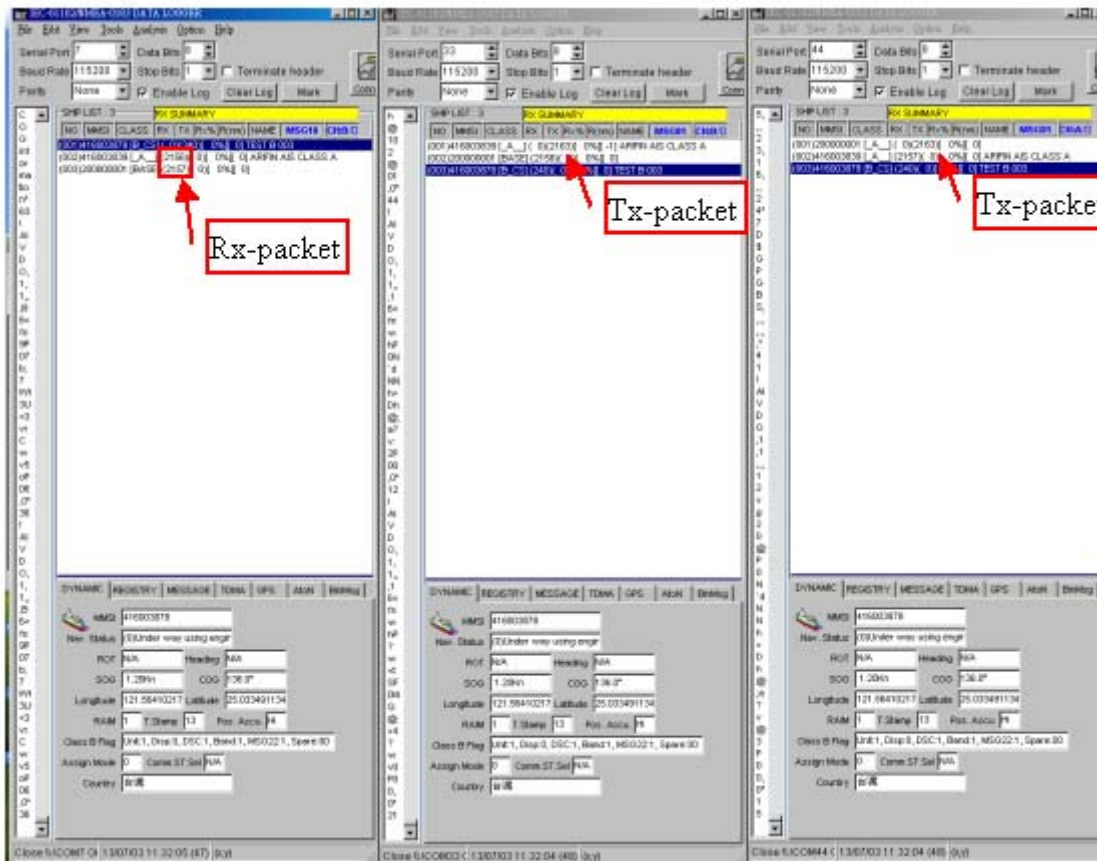

Product	AIS Class B Transponder		
Test Item	Radiated susceptibility		
Test Mode	Mode 2: DC 24V		
Date of Test	2013/07/03	Test Site	Chamber 5

Frequency (MHz)	Position (Angle)	Polarity (H or V)	Field Strength (V/m)	Required Criteria	Complied To Criteria (A,B,C)	Results
AM 80% Modulated with 400Hz						
80-2000	0°	H	10	A	A	PASS
80-2000	0°	V	10	A	A	PASS
80-2000	90°	H	10	A	A	PASS
80-2000	90°	V	10	A	A	PASS
80-2000	180°	H	10	A	A	PASS
80-2000	180°	V	10	A	A	PASS
80-2000	270°	H	10	A	A	PASS
80-2000	270°	V	10	A	A	PASS

Note:

The testing performed is from lowest level up to the highest level as required by standard, but only highest level is shown on the report.

- Meet criteria A: Operate as intended during and after the test
- Meet criteria B: Operate as intended after the test
- Meet criteria C: Loss/Error of function
- Additional Information
 - There was no observable degradation in performance.
 - EUT stopped operation and could / could not be reset by operator at _____ V/m at frequency _____MHz.
- No false alarms or other malfunctions were observed during or after the test.

Test Record of Radiated Susceptibility

On the screenshot below, the transmitting packet quantity (of the additional AIS transponder) is marked by “Tx-packet” which is 4323 (2162 plus 2161). The receiving packet quantity of the EUT is marked by “Rx-packet” which is 4311 (2155 plus 2156). Therefore, the PER (Packet Error Rate) of the EUT receiving performance under this test is 0.28%.

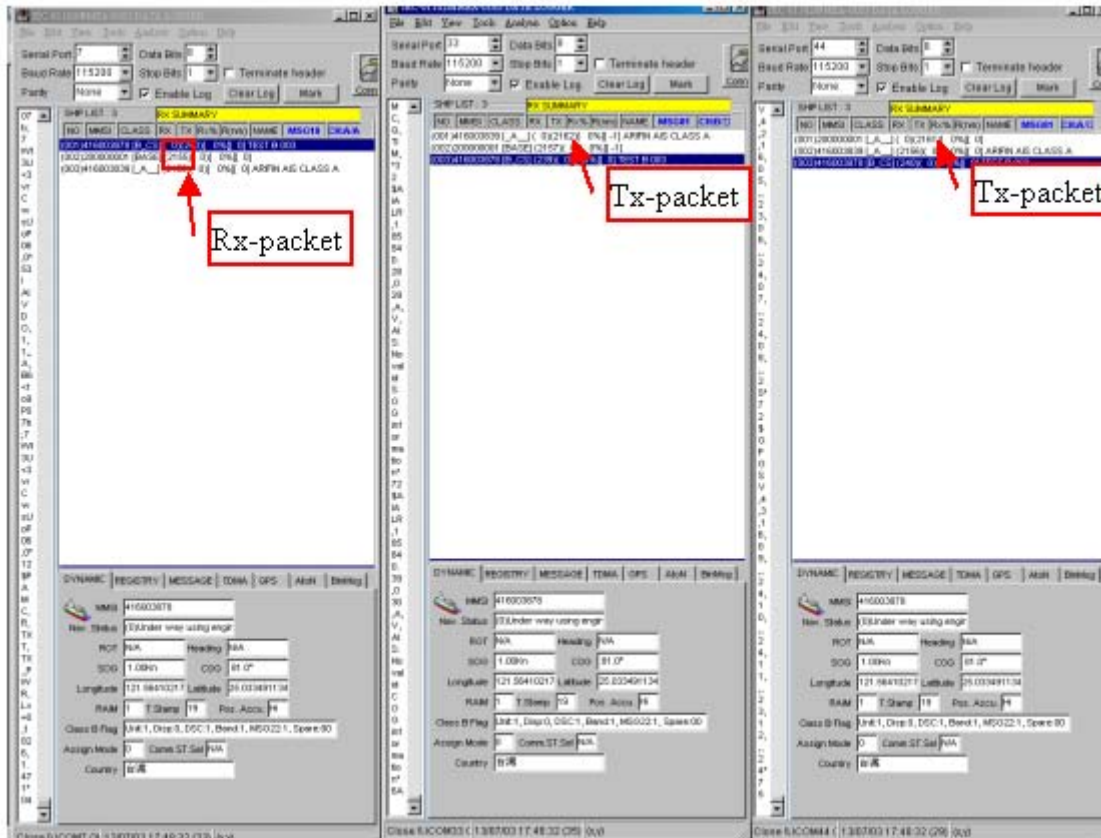

6.7. Test Photograph

Test Mode : Mode 1: DC 12V

Description : Radiated Susceptibility Test Setup



Test Mode : Mode 2: DC 24V

Description : Radiated Susceptibility Test Setup



7. Electrical Fast Transient/Burst

7.1. Test Specification

According to Standard : IEC 60945

7.2. Test Setup

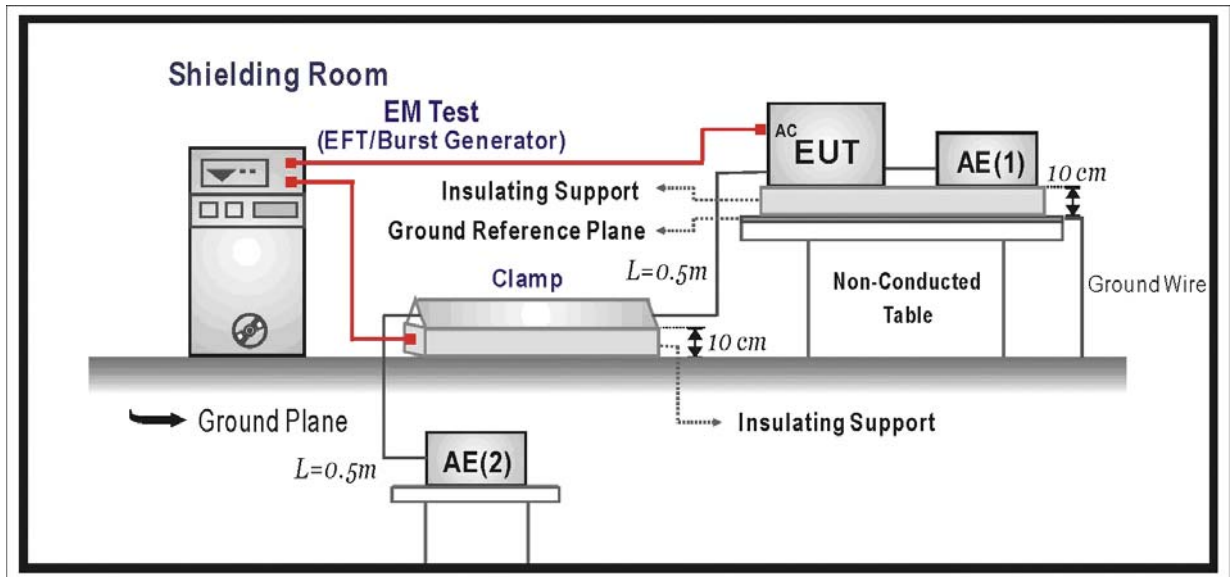

7.3. Limit

Item	Environmental Phenomena	Units	Test Specification	Performance Criteria
I/O and communication ports				
	Fast Transients Common Mode	kV (Peak) Tr/Th ns Rep. Frequency kHz	+1 5/50 5	B
Input AC Power Ports				
	Fast Transients Common Mode	kV (Peak) Tr/Th ns Rep. Frequency kHz	+2 5/50 5	B

Note: Tolerances

Burst duration and period ±20%

Source impedance ±20%

Amplitude ±10%

7.4. Test Procedure

The EUT is placed on a table that is 0.8 meter height. A ground reference plane is placed on the table, and uses a 0.1m insulation between the EUT and ground reference plane.

The minimum area of the ground reference plane is 1m*1m, and 0.65mm thick min, and projected beyond the EUT by at least 0.1m on all sides.

Test on I/O and communication ports:

The EFT interference signal is through a coupling clamp device couples to the signal and control lines of the EUT with burst noise for 1 minute.

Test on power supply ports:

The EUT is connected to the power mains through a coupling device that directly couples the EFT/B interference signal.

Each of the Line and Neutral conductors is impressed with burst noise for 3 to 5 minute.

The length of the signal and power lines between the coupling device and the EUT is 0.5m.

7.5. Deviation from Test Standard

No deviation.

7.6. Test Result

Product	AIS Class B Transponder		
Test Item	Electrical fast transient/burst		
Test Mode	Mode 1: DC 12V		
Date of Test	2013/07/03	Test Site	No.3 Shielded Room

Inject Line	Polarity	Voltage kV	Inject Time (Second)	Inject Method	Required Criteria	Complied to Criteria	Result
VHF	±	1kV	300	Clamp	B	A	PASS
GPS	±	1kV	300	Clamp	B	A	PASS
NMEA0183	±	1kV	300	Clamp	B	A	PASS
NMEA2000	±	1kV	300	Clamp	B	A	PASS
USB	±	1kV	300	Clamp	B	A	PASS

Note:

The testing performed is from lowest level up to the highest level as required by standard, but only highest level is shown on the report.

- Meet criteria A : Operate as intended during and after the test
- Meet criteria B : Operate as intended after the test
- Meet criteria C : Loss/Error of function
- Additional Information
 - EUT stopped operation and could / could not be reset by operator at _____ kV of Line _____.
- No false alarms or other malfunctions were observed during or after the test.

Test Record of Electrical Fast Transient/Burst

On the screenshot below, the transmitting packet quantity (of the additional AIS transponder) is marked by “Tx-packet” which is 696 (348 plus 348). The receiving packet quantity of the EUT is marked by “Rx-packet” which is 695 (347 plus 348).

Therefore, the PER (Packet Error Rate) of the EUT receiving performance under this test is 0.14%.

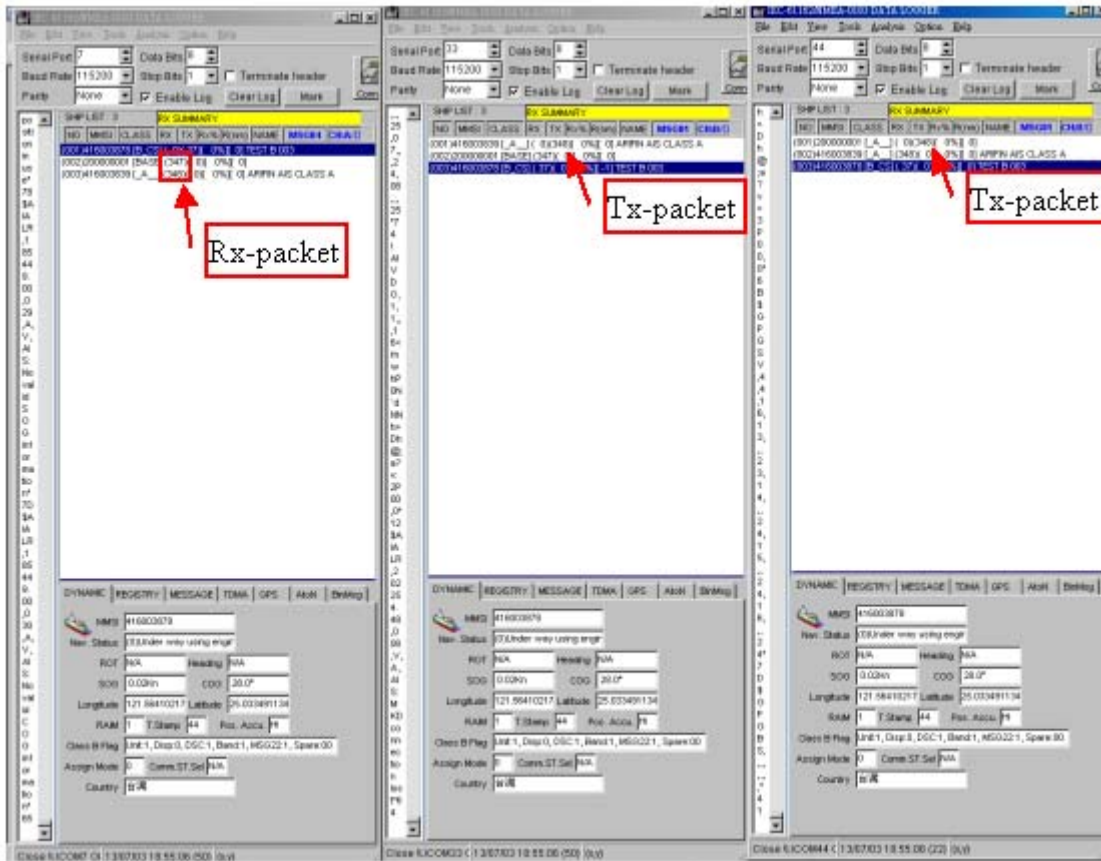

Product	AIS Class B Transponder		
Test Item	Electrical fast transient/burst		
Test Mode	Mode 2: DC 24V		
Date of Test	2013/07/03	Test Site	No.3 Shielded Room

Inject Line	Polarity	Voltage kV	Inject Time (Second)	Inject Method	Required Criteria	Complied to Criteria	Result
VHF	±	1kV	300	Clamp	B	A	PASS
GPS	±	1kV	300	Clamp	B	A	PASS
NMEA0183	±	1kV	300	Clamp	B	A	PASS
NMEA2000	±	1kV	300	Clamp	B	A	PASS
USB	±	1kV	300	Clamp	B	A	PASS

Note:

The testing performed is from lowest level up to the highest level as required by standard, but only highest level is shown on the report.

- Meet criteria A : Operate as intended during and after the test
- Meet criteria B : Operate as intended after the test
- Meet criteria C : Loss/Error of function
- Additional Information
 - EUT stopped operation and could / could not be reset by operator at _____ kV of Line _____.
- No false alarms or other malfunctions were observed during or after the test.

Test Record of Electrical Fast Transient/Burst

On the screenshot below, the transmitting packet quantity (of the additional AIS transponder) is marked by “Tx-packet” which is 694 (347 plus 347). The receiving packet quantity of the EUT is marked by “Rx-packet” which is 692 (346 plus 346).

Therefore, the PER (Packet Error Rate) of the EUT receiving performance under this test is 0.29%.

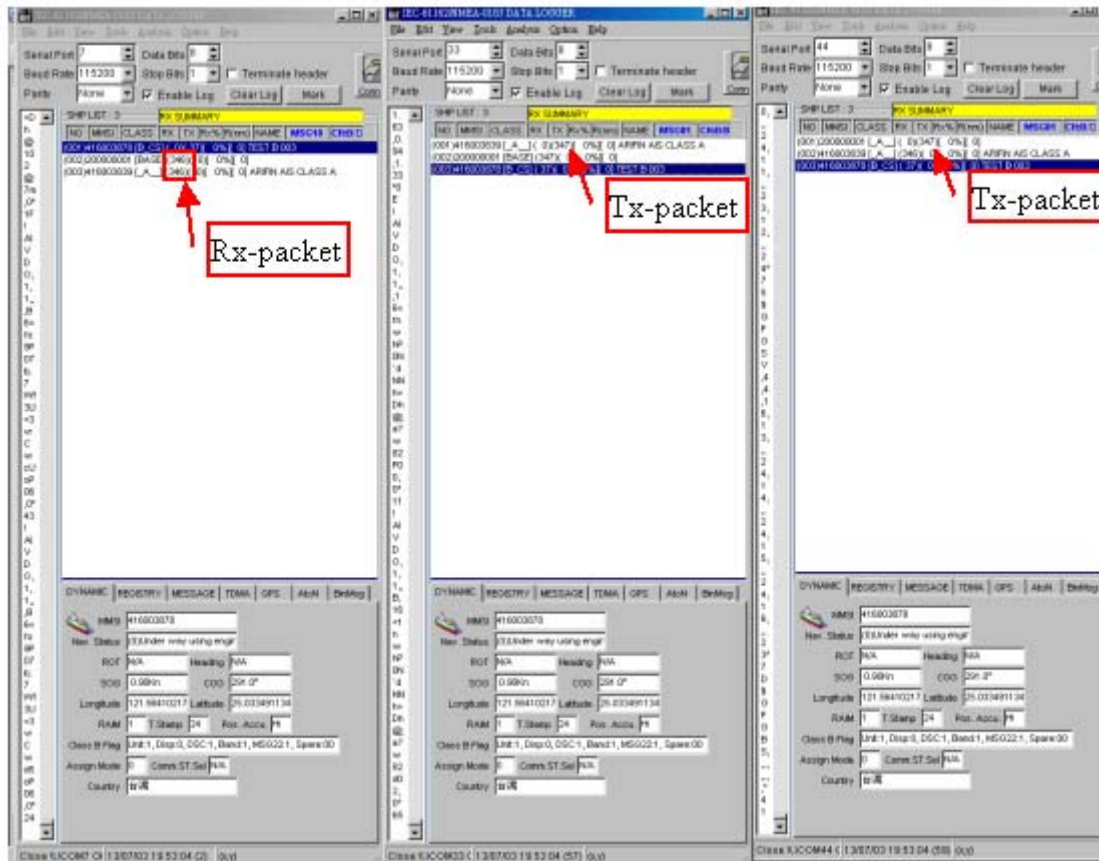

7.7. Test Photograph

Test Mode : Mode 1: DC 12V

Description : EFT/B Test Setup-Clamp



Test Mode : Mode 2: DC 24V

Description : EFT/B Test Setup-Clamp



8. Power Supply Failure

8.1. Test Specification

According to Standard : IEC 60945

8.2. Test Setup

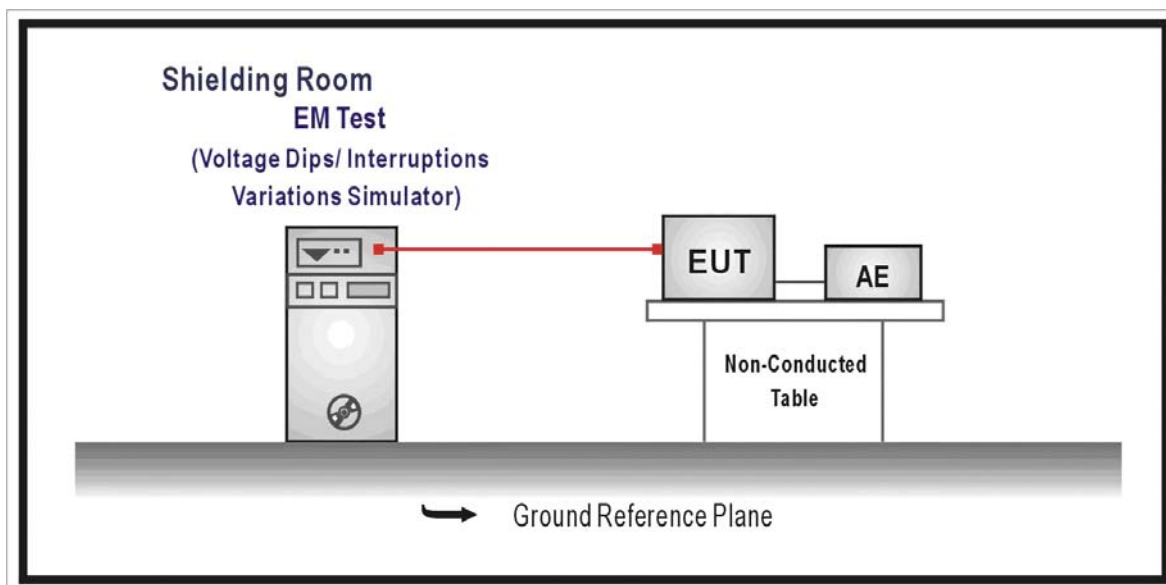

8.3. Limit

Item	Environmental Phenomena	Test Specification
	Input Power Ports	
	Power supply failure	60 s interruption a.c. and d.c. power ports Performance criterion C

8.4. Test Procedure

The EUT and its load are placed on a table which is 0.8 meter above a metal ground plane.

The EUT shall be subjected to three breaks in power supply of duration 60 s each.

Further information is in IEC 61000-4-11.

8.5. Deviation from Test Standard

No deviation.

8.6. Test Result

Product	AIS Class B Transponder		
Test Item	Power Supply Failure		
Test Mode	Mode 1: DC 12V		
Date of Test	2013/07/03	Test Site	No.3 Shielded Room

Voltage Interruptions (DC)	Reduction (%)	Duration (s)	Test Result
	100	60	PASS

On the screenshot below, the transmitting packet quantity (of the additional AIS transponders) is marked by “Tx-packet” which is 115 (58 plus 57). Due to EUT takes three times of power breaks, hence the actual receiving packet time should be around 6 to 7 minutes. Therefore, the expected average packet quantities should be 39 + 39 (1 report per 10 seconds). The real receiving packet quantity by the EUT is marked by “Rx-packet” which is 71 (35 plus 36). Therefore, the receiving performance under this test condition is 8.9%.

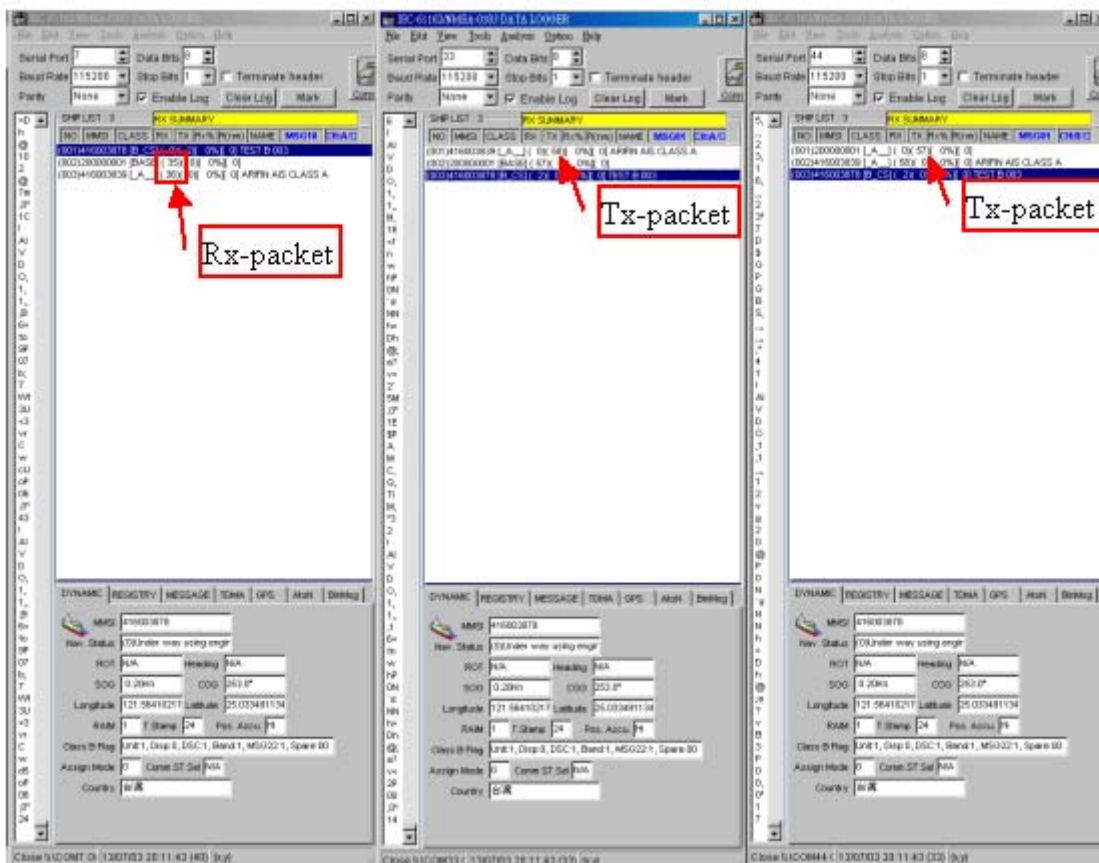

Product	AIS Class B Transponder		
Test Item	Power Supply Failure		
Test Mode	Mode 2: DC 24V		
Date of Test	2013/07/03	Test Site	No.3 Shielded Room

Voltage Interruptions (DC)	Reduction (%)	Duration (s)	Test Result
	100	60	PASS

On the screenshot below, the transmitting packet quantity (of the additional AIS transponders) is marked by “Tx-packet” which is 118 (59 plus 59). Due to EUT takes three times of power breaks, hence the actual receiving packet time should be around 6 to 7 minutes. Therefore, the expected average packet quantities should be 39 + 39 (1 report per 10 seconds). The real receiving packet quantity by the EUT is marked by “Rx-packet” which is 76 (38 plus 38). Therefore, the receiving performance under this test condition is 2.56%.

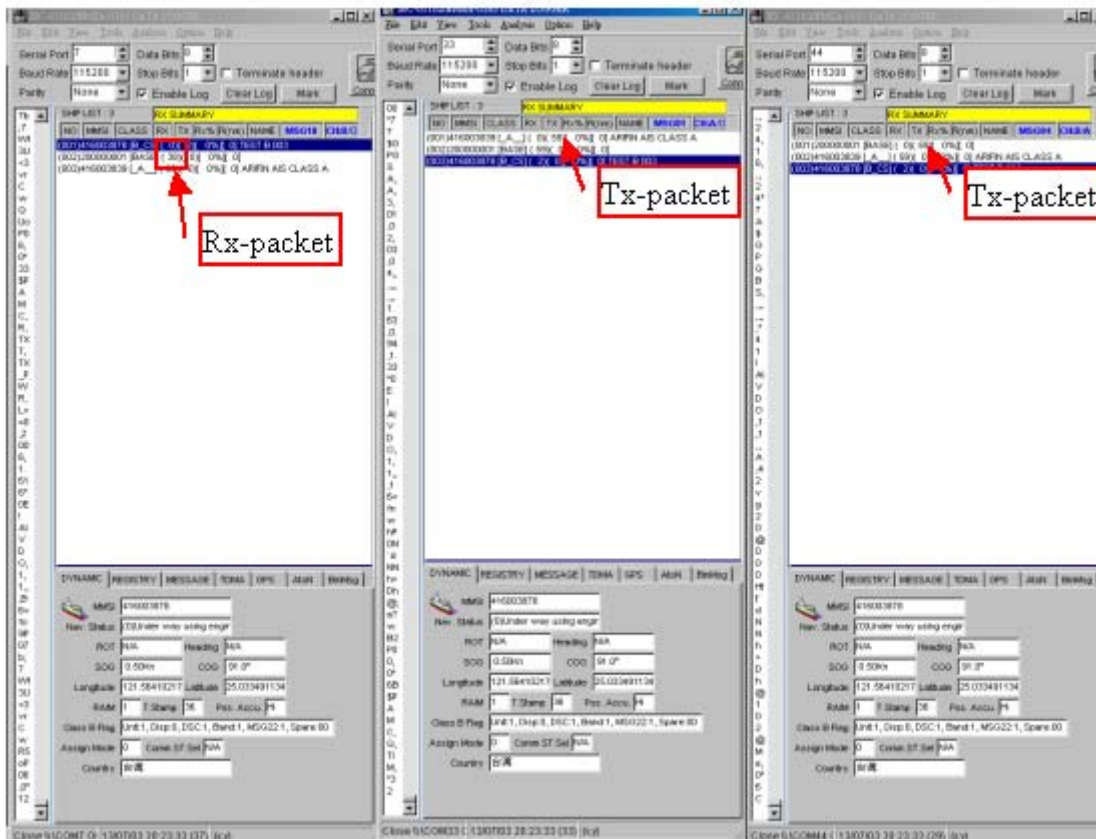

8.7. Test Photograph

Test Mode : Mode 1: DC 12V

Description : Power Supply Failure



Test Mode : Mode 2: DC 24V

Description : Power Supply Failure



9. Electrostatic Discharge

9.1. Test Specification

According to Standard : IEC 60945

9.2. Test Setup

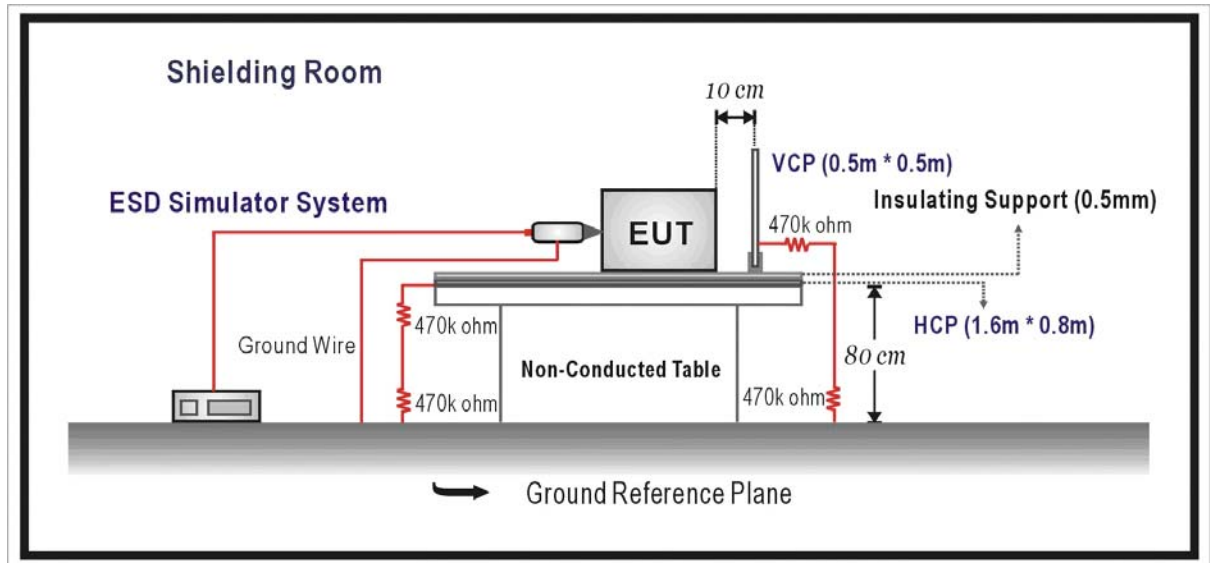

9.3. Limit

Item	Environmental Phenomena	Units	Test Specification	Performance Criteria
Enclosure Port				
	Electrostatic Discharge	kV(Charge Voltage)	±8 (Air Discharge) ±6 (Contact Discharge)	B

9.4. Test Procedure

Direct application of discharges to the EUT:

Contact discharge was applied only to conductive surfaces of the EUT.

Air discharges were applied only to non-conductive surfaces of the EUT.

During the test, it was performed with single discharges. For the single discharge time between successive single discharges will be keep longer 1 second. It was at least ten single discharges with positive and negative at the same selected point.

The selected point, which was performed with electrostatic discharge, was marked on the red label of the EUT.

Indirect application of discharges to the EUT:

Vertical Coupling Plane (VCP):

The coupling plane, of dimensions 0.5m x 0.5m, is placed parallel to, and positioned at a distance 0.1m from, the EUT, with the Discharge Electrode touching the coupling plane.

The four faces of the EUT will be performed with electrostatic discharge. It was at least ten single discharges with positive and negative at the same selected point.

Horizontal Coupling Plane (HCP):

The coupling plane is placed under to the EUT. The generator shall be positioned vertically at a distance of 0.1m from the EUT, with the Discharge Electrode touching the coupling plane.

The four faces of the EUT will be performed with electrostatic discharge. It was at least ten single discharges with positive and negative at the same selected point.

9.5. Deviation from Test Standard

No deviation.

9.6. Test Result

Product	AIS Class B Transponder		
Test Item	Electrostatic Discharge		
Test Mode	Mode 1: DC 12V		
Date of Test	2013/07/03	Test Site	No.6 Shielded Room

Item	Amount of Discharge	Voltage	Required Criteria	Complied To Criteria (A,B,C)	Results
Air Discharge	10	+8kV	B	A	Pass
	10	-8kV	B	A	Pass
Contact Discharge	25	+6kV	B	A	Pass
	25	-6kV	B	A	Pass
Indirect Discharge (HCP)	25	+6kV	B	A	Pass
	25	-6kV	B	A	Pass
Indirect Discharge (VCP)	25	+6kV	B	A	Pass
	25	-6kV	B	A	Pass

Note:

The testing performed is from lowest level up to the highest level as required by standard, but only highest level is shown on the report.

NR: No Requirement

- Meet criteria A: Operate as intended during and after the test
- Meet criteria B: Operate as intended after the test
- Meet criteria C: Loss/Error of function
- Additional Information
 - EUT stopped operation and could / could not be reset by operator at ____ kV.
 - No false alarms or other malfunctions were observed during or after the test.

Remark:

The Contact discharges were applied at least total 200 discharges at a minimum of four test points.

Test Record of Electrostatic Discharge

On the screenshot below, the transmitting packet quantity (of the additional AIS transponder) is marked by "Tx-packet" which is 654 (327 plus 327). The receiving packet quantity of the EUT is marked by "Rx-packet" which is 652 (326 plus 326).

Therefore, the PER (Packet Error Rate) of the EUT receiving performance under this test is 0.31%.

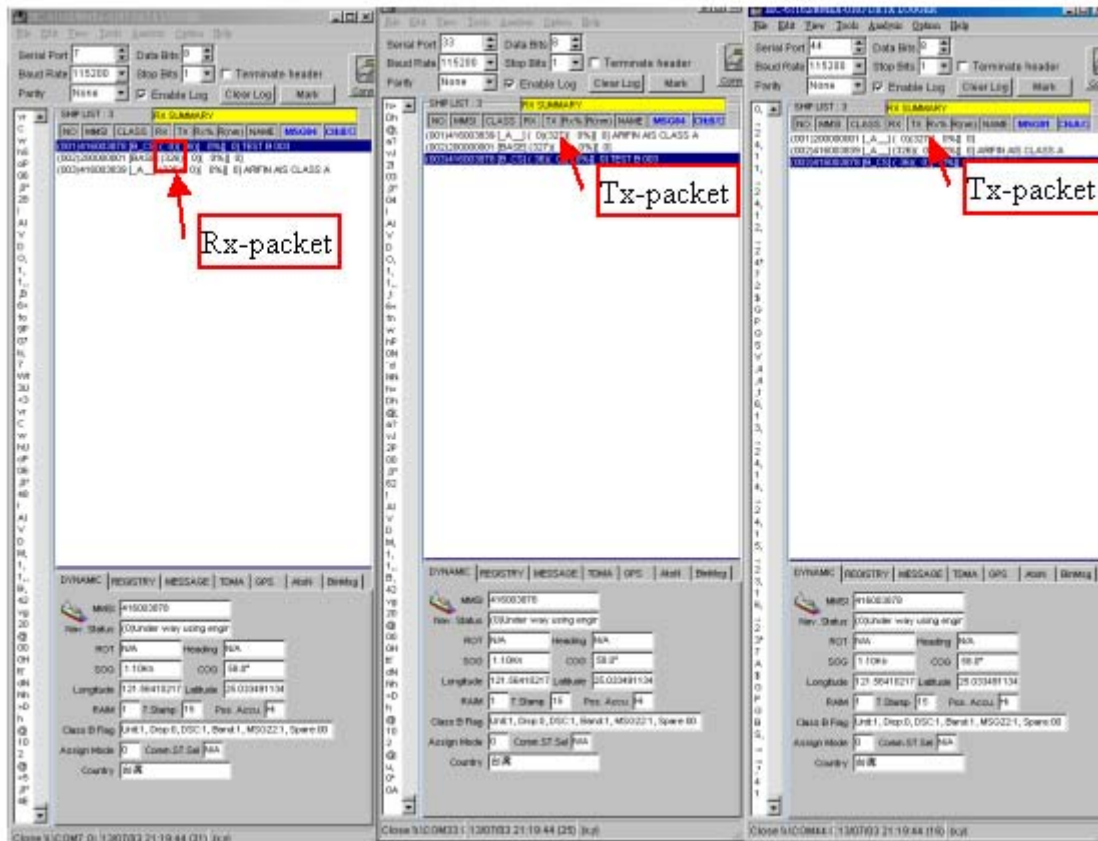

Product	AIS Class B Transponder		
Test Item	Electrostatic Discharge		
Test Mode	Mode 2: DC 24V		
Date of Test	2013/07/03	Test Site	No.6 Shielded Room

Item	Amount of Discharge	Voltage	Required Criteria	Complied To Criteria (A,B,C)	Results
Air Discharge	10	+8kV	B	A	Pass
	10	-8kV	B	A	Pass
Contact Discharge	25	+6kV	B	A	Pass
	25	-6kV	B	A	Pass
Indirect Discharge (HCP)	25	+6kV	B	A	Pass
	25	-6kV	B	A	Pass
Indirect Discharge (VCP)	25	+6kV	B	A	Pass
	25	-6kV	B	A	Pass

Note:

The testing performed is from lowest level up to the highest level as required by standard, but only highest level is shown on the report.

NR: No Requirement

- Meet criteria A: Operate as intended during and after the test
- Meet criteria B: Operate as intended after the test
- Meet criteria C: Loss/Error of function
- Additional Information
 - EUT stopped operation and could / could not be reset by operator at ____ kV.
 - No false alarms or other malfunctions were observed during or after the test.

Remark:

The Contact discharges were applied at least total 200 discharges at a minimum of four test points.

Test Record of Electrostatic Discharge

On the screenshot below, the transmitting packet quantity (of the additional AIS transponder) is marked by “Tx-packet” which is 651 (326 plus 325). The receiving packet quantity of the EUT is marked by “Rx-packet” which is 650 (325 plus 325).

Therefore, the PER (Packet Error Rate) of the EUT receiving performance under this test is 0.15%.

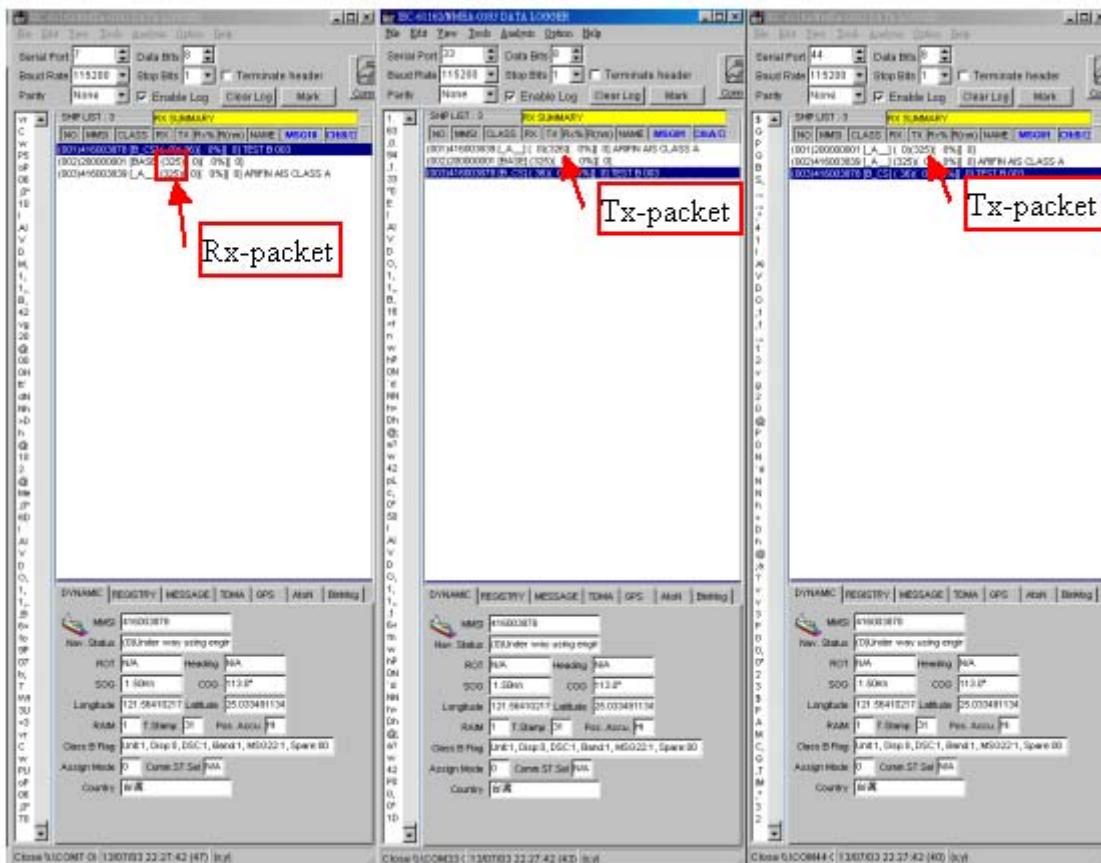

9.7. Test Photograph

Test Mode : Mode 1: DC 12V

Description : ESD Test Setup

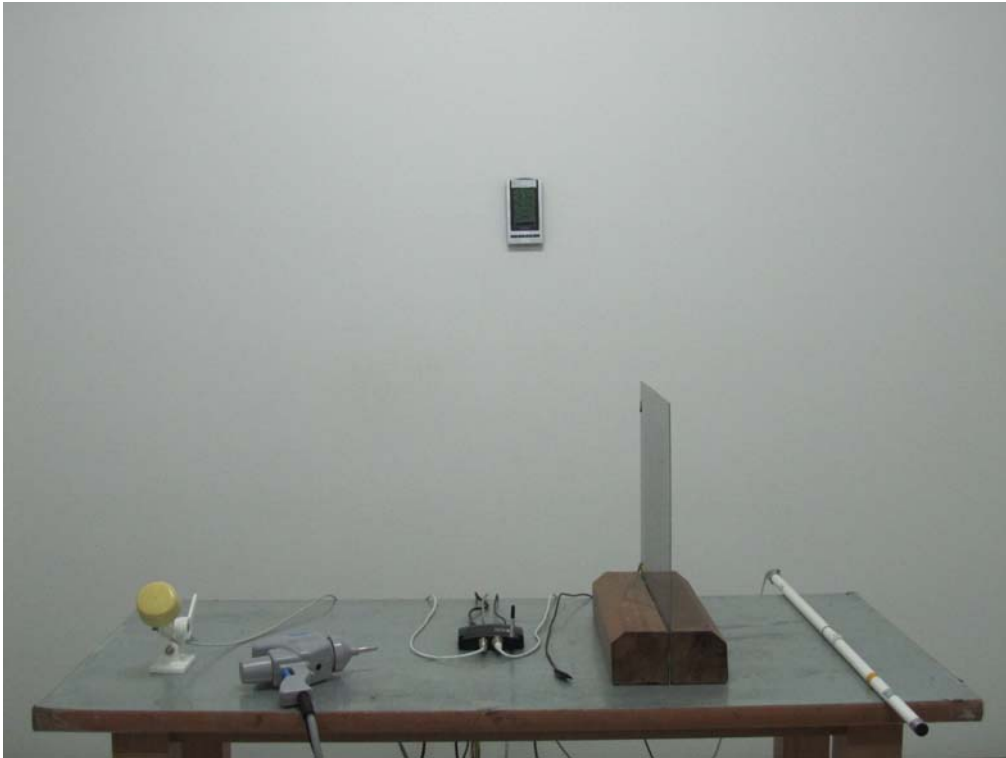

Test Mode : Mode 2: DC 24V

Description : ESD Test Setup



10. Electromagnetic Radio Frequency Radiation

10.1. Test Equipment

Equipment	Manufacturer	Model No.	Last Cal.
Field Probe	SCHAFFNER	EMC20	September, 2012

10.2. Method of test

Use Field probe to measure power density and find appropriate the maximum distance from the EUT at which the power density level of $100W/m^2$ and $10W/ m^2$.

10.3. Test Result and photos

The power density of EUT are very smaller than $100W/m^2$ and $10W/ m^2$, when field probe completely close to EUT.

(1) Measure Result:



11. Attachment

➤ EUT Photograph

(2) EUT Photo



(3) EUT Photo



(4) EUT Photo



(5) EUT Photo



(6) EUT Photo

